



PEEK Wear Test System Final Report

Ken Gamble

June 12, 2014

Team Sprocket

Michael Brown
mbrown38@calpoly.edu

Mason Chellemi
mason.chellemi@gmail.com

Allian Roman
anroman@calpoly.edu

Table of Contents

List of Tables	iv	
List of Figures	v	
Abstract	vi	
Chapter		
1	Introduction	1
	1.1 Sponsor Background and Need	1
	1.2 Objectives	1
	1.3 Responsibility Subdivision	4
2	Background Information	4
	2.1 Existing Chain Drive Testing Machines	4
	2.2 Previous Work on PEEK Composite Wear Characteristics	5
	2.3 Measuring Sprocket Wear	5
3	Design Development	7
	3.1 Concept Selection Process	7
	3.1.1 Fixture Frame and Test Platform Concept	7
	3.1.2 Electric Motor Concept	9
	3.1.2a Power	9
	3.1.2b Speed	10
	3.1.2c Motor Induction Types	10
	3.1.3 Chain Tensioning Concept	11
	3.1.3a Spring Force	11
	3.1.3b Hydraulic	12
	3.1.3c Pneumatic Actuator	12
	3.1.3d Electro-mechanical Actuators	12
	3.1.3e Gravitational Force	13
	3.1.4 Wear Measurement Concept	13
	3.1.4a Water Displacement	13
	3.1.4b Dimension Measurement Device	13
	3.1.4c Image Processing Software	14
	3.1.4d Digital Mass Measurement	14
	3.2 Final Concepts Selected	14
	3.2.1 Test Platform and Fixture Frame	14
	3.2.2 Motor	14

	3.2.3 Chain Tension	15
	3.2.4 Wear Measurement	16
	3.2.5 Final Concepts Selected Combined	17
	3.3 Final Concepts Approved	17
4	Final Design	17
	4.1 Overall Design Description	18
	4.1.1 Frame Design Details	19
	4.1.2 Drivetrain Design Details	20
	4.1.3 Electro-mechanical Design Details	20
	4.1.4 Linear Motion Design Details	20
	4.1.5 Safety Design Details	21
	4.2 Supporting Analysis	21
	4.2.1 Motor Selection	21
	4.2.2 Bearing Selection	22
	4.2.3 Safety Selection	24
	4.3 Maintenance and Repair	26
	4.4 Cost Analysis	26
5	Product Realization	29
	5.1 Manufacturing Process	29
	5.1.1 Table Modification	30
	5.1.2 Enclosure	31
	5.1.3 Drivetrain	32
	5.1.3a Spacer Blocks	32
	5.1.3b Drive Shaft	32
	5.1.3c Sprocket Holder	32
	5.1.3d Hub	33
	5.1.3e Swingarm	33
	5.1.3f Assembly	34
	5.1.4 Pneumatics	34
	5.1.5 Wiring	35
	5.1.6 “Bells and Whistles”	36
	5.2 Deviations from Final Design	36
	5.3 Manufacturing Recommendations	37
6	Design Verification Plan (Testing)	38
	6.1 Test Descriptions	38
	6.1.1 Weight and Mobility Test	38
	6.1.2 Chain Test	38
	6.1.3 Actuator Test	38

6.1.4 Mount Deflection Test	39
6.1.5 Power Test	39
6.1.6 Noise Test	39
6.1.7 Temperature Test	39
6.1.8 Wear Test	39
6.2 Design Verification Plan and Report (DVPR)	29
6.2.1 Weight and Mobility Test Results	41
6.2.2 Chain Test Results	41
6.2.3 Actuator Test Results	41
6.2.4 Mount Deflection Test Results	41
6.2.5 Power Test Results	41
6.2.6 Noise Test Results	42
6.2.7 Temperature Test Results	42
6.2.8 Wear Test Results	42
7 Conclusions and Recommendations	43
Works Cited	44
Appendix A Additional Figures	45
Appendix B Detailed Supporting Analysis	46
Appendix C QFD House of Quality	47
Appendix D Final Drawings and Parts Lists	48
Appendix E Detailed Cost Analysis	64
Appendix F Technical Manual	67

List of Tables

Table 1 Engineering Specifications and Targets	3
Table 2 Preliminary Sprocket Mass Loss Results	6
Table 3 Motor Type Comparison	10
Table 4 Criteria Definitions for Motor Selection	14
Table 5 Decision Matrix for Motor Selection	14
Table 6 Decision Matrix for Chain Tension	15
Table 7 Decision Matrix for Wear Measurement	16
Table 8 Results of Bearing Load-Life Analysis	24
Table 9 Estimated Cost Analysis	27
Table 10 Original Manufacturing/Assembly Plan	29
Table 11 Design Verification Plan and Report (DVPR)	40
Table 12 Results of Noise Test	42
Table 13 Results of Temperature Test	42
Table 14 Results of Al. Wear Test After 29 Hours	42

List of Figures

Figure 1 Sprocket Tooth Wear	5
Figure 2 Generic Motorcycle Concept	7
Figure 3 Upright Sprocket Concept	7
Figure 4 Polycarbonate and Aluminum Extrusion Enclosure	8
Figure 5 Final Concepts Combined	17
Figure 6 Overall Labeled Fixture Design	18
Figure 7 Labeled Drivetrain Design	19
Figure 8 Table and Tabletop, Before Modifications	30
Figure 9 Loading the Tabletop inside the VF-3	30
Figure 10 The Assembled Enclosure with Chair Guards	31
Figure 11 Bearing Spacer Blocks for the Drive Shaft	32
Figure 12 Sprocket Holder	33
Figure 13 CRF 450 Hub	33
Figure 14 Swingarm with hub/axle Installed	34
Figure 15 Installed Drivetrain	34
Figure 16 Pressure Regulator/Valve and Hose	34
Figure 17 Wiring Schematic	35
Figure 18 Final Fixture	36
Figure 19 Belt/Pulley Speed Reducer Close-Up	37

Abstract

The wear characteristics of PEEK carbon fiber composites are not well understood in comparison to high strength materials in common use such as steel, aluminum, and carbon fiber epoxy. This lack of understanding limits the applications in which the superior strength to weight ratio and stiffness of PEEK carbon fiber composites may be utilized with confidence to situations in which there are no significant bearing surface interactions between nearby components. The objective of this project was to design, build, and test a machine that is capable of evaluating the behavior of PEEK carbon fiber composites in a long term, high contact environment, and compare their performance directly against more familiar materials, like steel, aluminum, and carbon fiber epoxy.

1. Introduction

The purpose of this report is to present a detailed description of the final design for the wear testing fixture, including, cost, manufacturing, and testing results. In this chapter, the background and need of the sponsor are stated, and the engineering specifications and their development are explained.

1.1 Sponsor Background and Need

The sponsor for this project was Quatro Composites, a leader in the design and manufacture of advanced composite components for aerospace, defense, medical, and industrial uses. In recent years the company has begun utilizing carbon-fiber and Polyetheretherketone (PEEK) composite material to make structural airliner brackets. While the composite is well known for its toughness and impact resistance, Quatro Composites was interested in the abrasion resistance characteristics of carbon-fiber and PEEK (carbon-fiber/PEEK) to further develop the material's potential and implementation in other airliner components.

In order to acquire data on the abrasion resistance characteristics of carbon-fiber/PEEK, Quatro Composites proposed the design and manufacture of a wear testing fixture to execute long term wear tests. Furthermore, the company specified that a motorcycle chain and sprocket would serve as the test platform. In this classic roller-chain drive system, consisting of two sprockets and a roller chain, the driven sprocket was to be made of carbon-fiber/PEEK and would be the test piece. Hence, the roller chain would generate the wear. Additionally, the fixture would allow for interchangeable test pieces in order to obtain the wear characteristics of steel, aluminum and carbon-fiber epoxy, for comparison.

The stakeholders of this project were Ken Gamble, the project's main contact, Quatro Composites, and the three Cal Poly mechanical engineering students undertaking the task: Michael Brown, Mason Chellemi, and Allian Roman. This project represented our senior project, a capstone engineering experience required for the completion of our degree. The project spanned three academic quarters during which a formal engineering design process was used and, the project culminated with the successful construction of the fixture that can perform long-duration tests to obtain quantifiable results on the wear characteristics of carbon-fiber/PEEK composites. The long term test were attempted, and the results of these tests will potentially benefit the clients of Quatro Composites and the industries they serve by supporting the future use of carbon-fiber/PEEK composites in new ways.

1.2 Objectives

To meet the goals of successfully designing and building the wear testing fixture, as well as executing the wear tests, a list of engineering specifications was established to guide the design process. In order to develop the specifications, and ultimately the solution, that strongly satisfied the customer's need, the Quality Function Deployment (QFD) method was used. In the QFD

approach, a House of Quality was used to visually organize the customer's needs, and the engineering requirements to develop the most effective project specifications. The house of quality used for this project is included in Appendix C, and Table 1 lists the design targets, and a compliance and risk assessment for each.

The engineering requirements addressed the matters of geometry, safety, power, and optimal operation and served as a checklist to see that all aspects of this design were identified. As the project developed, two specifications were altered (Specs. # 1 and # 5) from their original target, one specification was removed (Spec. # 2), and one new specification was identified (Spec. # 14).

Originally, the fixture was anticipated to weigh less than 125 lbs, to measure 3' x 6', and to require approximately 20 lbs of force when rolled by one person. However, after the initial specifications were developed, Quatro Composites asked the team to use an existing rolling table with an aluminum plate tabletop. The existing table, now implemented in the final design, measures 2.5' x 4' and weighs more than 125 lbs. The specifications were amended to accommodate the new fixture frame, and it was concluded that the machine should weigh less than 250 lbs and should require no more than 40 lbs of force when rolled by one person. Spec # 2, which identified the dimensions of the tabletop, was removed, and the dimensions became fixed to those of the existing table. The new specification (# 14) addressed the amount of wear that must be generated in order to be measured easily, and specifically the fixture needed to generate at least 3% wear. The details of the development of Spec. # 14 are found in section 2.3. All other original specifications remained unchanged and are subsequently discussed.

To develop a system that can be situated anywhere in the Quatro Composites facility, the fixture needed to operate on 110V and was therefore required to be powered by any wall outlet. Secondly, to design a fixture that can be demonstrated to future Quatro Composite clients the system needed to include recessed hardware, polished surface finish, and could not generate more than 80 dB of noise. In this way, the machine would possess good aesthetics, and its operation would not cause undue auditory discomfort. Thirdly, the test fixture was to be 99% reliable, rated for 5000 continuous hours of life, have automatic photo capture, motor cooling, variable chain tension, and would allow for the interchangeability of test sprockets. This would allow the test fixture to be used to conduct controlled experiments that accurately compare the wear rates of the materials chosen. Lastly and most importantly, the test fixture needed to encompass all safety precautions that meet Cal Poly Health and Safety regulations. Hence, the fixture would entail automatic shut-off switches, shatter-proof enclosure, and appropriate filtering, if necessary, to protect operators from carbon-fiber dust particles.

After establishing the list of requirements, a risk factor was assigned to each target in which a High (H), Medium (M), or Low (L) designation indicates the difficulty anticipated in meeting the requirement. There were no high risk targets identified, and the most difficult requirements were

life, noise, reliability, and time-lapse. Careful analysis and planning in the design phase was anticipated to help address these challenging targets. Finally, a compliance method was determined in which a Test (T), Analysis (A), Inspection (I), or Similarity to Existing Designs (S) designation indicated how each specification would be met. All of the specifications required testing, analysis, or visual inspection, and their verification are discussed in greater detail in chapter 6.

Table 1 Engineering Specifications and Targets

Spec. #	Parameter Description	Requirement or Target (units)	Tolerance	Risk	Compliance Method
1	Weight	250 lbs.	Max	L	T
2	Size	3'x6'	Max	L	T
3	Life	5000 continuous hours	Min	M	A
4	Reliability	99%	Min	M	A
5	Mobility	40 lbs. force required when rolled by one person	Max	L	A
6	Power	110 V		L	T
7	Noise	80 dB	Max	M	T
8	Safety	Pass Campus Health & Safety Inspection	Min	L	I
9	Aesthetics	Recessed hardware, polished surface finish	N/A	L	I
10	Time-lapse	Automatic hourly photo capture	N/A	M	T
11	Control operation	Motor cooling system	N/A	L	T
12	Interchangeable test subject	Use of fasteners to fix sprocket to hub	N/A	L	I
13	Adjustability	Variable chain tensioner	N/A	L	T
14	Measurable wear	3% wear	Min	L	T

1.3 Responsibility Subdivision

The management of the team and its task schedule was determined by the division of the machine design process into separate subsystems and responsibilities. Three managerial positions were identified and assigned. As Communications Officer, Mason Chellemi was the main point of contact and facilitated all correspondence between the team and sponsor. As treasurer, Mason was also responsible for constructing a cost plan and maintained the team's budget for the duration of the project. As Secretary, Allian Roman organized the team's information repositories, both physical and electronic.

Furthermore, the complete design was composed of four individual subsystems. These subsystems include the machine's structure, drivetrain, composites, and electro-mechanics. Mason was responsible for the design of the structure, which included the structure of the testing machine along with its mobility components. Mason was responsible for the drivetrain of the test machine, including the design and selection of the chain tensioner, shafts, bearings, and mounts. Allian was in charge of the composites aspect of the project, including all aspects of the sprockets design and manufacture. Allian was also responsible for the testing management, the executing of the design verification and wear tests, and results reporting. Michael was in charge of the electro-mechanical subsystem, like electrical design, motor selection, calculating and estimating necessary specifications in order to carry out the wear tests, wiring, and electrical schematic. As the project developed new roles became necessary to develop. Subsequently, manufacturing and assembly was led by Allian, and pneumatic actuation was led by Mason.

2. Background Information

In order to solve the design problem presented, the team needed to research a number of topics. First, we looked into existing roller-chain drive testing machines to understand the mechanics and size limitations involved. Second, we researched carbon-fiber/PEEK wear to better identify the nuances of the material. Lastly, we investigated whether or not it was possible to measure the wear of a sprocket.

2.1 Existing Chain Drive Testing Machines

The motorcycle chain and sprocket that served as our test platform for demonstrating the long term wear resistance of carbon-fiber/PEEK composites is a classic roller-chain drive system. A number of testing machines similar to the one we developed have been created before. The roller-chain drive has long been a common method of transmitting mechanical power, but it has not always been well understood. Mechanical engineer James C. Conwell explains, in an article from the journal *Mechanisms and Machines*, that "chain drives were poorly understood through the 1980s for a variety of reasons, including the polygonal action, nontrivial sprocket geometry, intentional clearances and unintentional dimensional variations due to manufacturing tolerances, friction, and the large number of bodies that make up the typical chain and sprocket system" (525). Conwell created his own machine in the 1980s, which can be seen in Appendix A, to test

and measure the chain tension and impact forces on sprockets in a roller-chain drive (527). However, his device is not entirely unique and there are other similar devices, such as a machine patented in 1983 by Kurt M. Marshek and Michael O. Ross for testing chains and sprockets of different sizes and materials. This machine, of Appendix A, was used by its inventors to research the dynamic forces that lead to vibration in roller-chains. Their work was published by the American Society of Mechanical Engineers (ASME) (1). Since the 1980s, laboratory testing of roller-chain drives has resulted in the creation of a variety of additional machines designed to evaluate the mechanical characteristics of chain drive systems. The use of a roller-chain drives designed specifically for comparing the wear resistance of carbon-fiber composite sprockets to those made from traditional materials, is not well documented, if at all.

2.2 Previous Work PEEK Composite Wear Characteristics

Carbon-fiber reinforced PEEK composite is the primary sprocket material that needed to be evaluated for wear resistance. The mechanical properties of PEEK composite are better understood than the wear properties, however, there is some precedence for empirical wear testing. One example is the work published in the journal *Wear* by H. Voss and K. Friedrich of Hamburg Technical University's Polymer and Composites Group. Voss and Friedrich conducted a detailed set of tests on the wear resistance of short-fiber-reinforced PEEK composites. Their results indicated that, in most cases, increasing the volume fraction of fiber-reinforcement in PEEK resulted in a proportional decrease in the wear rate up until the fraction reached ten percent (9). This result is promising considering that PEEK on its own already possesses a low wear-rate in comparison to other thermoplastics (Thomas, 79).

2.3 Measuring Sprocket Wear

In order to attribute a wear rate to the sprockets after their time on the test fixture, an accurate method of capturing and quantifying the wear was necessary. Figure 1 shows the location of wear that typically occurs on a sprocket tooth, indicating that it is most pronounced along the pitch circle diameter. Measuring this wear can be difficult due to the large size of the sprocket, relative to the wear, and the uniqueness of the wear that can occur on each tooth. Additionally, depending on the length of the test, the amount of wear can be small and therefore challenging to view.

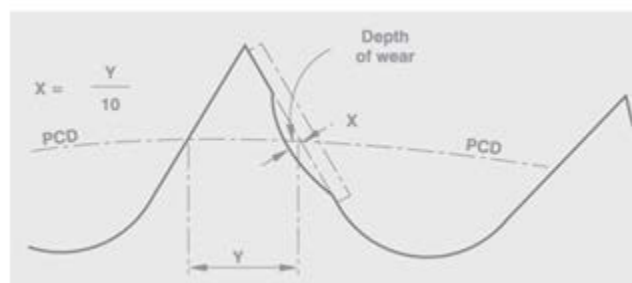

Figure 1 Sprocket Tooth Wear (“How to”)

To begin to understand this aspect of the problem, five worn sprockets were loaned to the team from a local motorcycle shop. The sprockets varied in size and material and each had spent a different length of time on the motorcycle from which it was removed. Hence, some teeth were significantly more worn than others. To associate an amount of wear with each sprocket, five new sprockets were purchased, of the exact models as the worn ones. An electronic mass balance was used to weigh the new and worn version of each case. The results are summarized in Table 2 and show that the percent of mass loss ranged from 2.5% to 9.7%. To help the reader understand this range of mass loss, a column titled “# of Pennies Equivalent” was created. Therefore, the sprockets that lost 2.5% of their original mass, lost as much mass as 3 pennies, and on the high end, the sprocket that lost 9.7% of its original mass, lost as much mass as 11 pennies. All of this information helped the team better understand the resolution needed to detect the anticipated wear resulting from the wear tests.

Since both a steel and aluminum sprocket exhibited 2.5% mass loss, the new engineering specification, Spec. # 14, was created. Spec. # 14 determined that the testing fixture needed to be able to generate at least 3% mass loss. Additionally, the results of this preliminary test showed that in general, steel is more wear resistant than aluminum. Therefore it was anticipated that generating measurable wear on the steel sprocket would be a challenge. Nevertheless, all of the information obtained from this preliminary test helped the team decide the best ways to measure the test pieces, and this aspect of the fixture was verified during the testing phase.

Table 2 Preliminary Sprocket Mass Loss Results

Make	Material	Part #	State	Avg. Mass g	Mass Loss g	# of Pennies Equivalent	% Mass
Vortex	Steel	526-43	New	385.8			
			Old	368.1	17.7	7	4.8
JT	Steel	JTR807-44	New	926.8			
			Old	904.0	22.8	9	2.5
Vortex	Aluminum	251A-41	New	248.8			
			Old	226.7	22.1	9	9.7
JT	Aluminum	JTA478-43	New	336.0			
			Old	328.0	8.1	3	2.5
Vortex	Aluminum	452A-43	New	369.1			
			Old	342.8	26.4	11	7.7

3. Design Development

Once the problem and engineering specifications were decided and confirmed by the sponsor, the team began idea generation and concept comparisons. Four subsystems were created and in each several concepts were considered in order to arrive at the best design that could meet the goals of the project. The final concepts selected, which make up the major components of the testing fixture, are discussed in the last section.

3.1 Concept Selection Process

The following is an introduction to the team's conceptual design selection process presented by subsystem. The subsystems consist of the test platform and fixture frame, motor, chain tensioning, and wear measurement.

3.1.1 Test Platform and Fixture Frame

The test platform, described in section 1.1, was specified by the sponsor as a motorcycle chain and sprocket system. In this roller-chain drive system, power is transmitted between two sprockets by use of a roller chain. For this testing fixture, the driven sprocket was to be made of carbon-fiber/PEEK and would be the test piece. Meanwhile, the driving sprocket was powered by an electric motor, and the roller chain generated the wear. Next, the orientation of the test platform was considered.

The first orientation considered was a generic motorcycle chain and sprocket set-up (Figure 2). This design sets up two sprockets and a chain in a horizontal fashion. The sprocket on the left is the one driven by the selected motor and the right sprocket is powered by the chain. The second orientation considered was an upright sprocket set-up (Figure 3). This design placed the drivetrain in a vertical position with the motor (represented with a cork) in the bottom-most compartment and the test sprocket in the top-most compartment. It was soon realized that the orientation of the platform would depend on the selected chain tensioning concept, which is described in section 3.2.3.

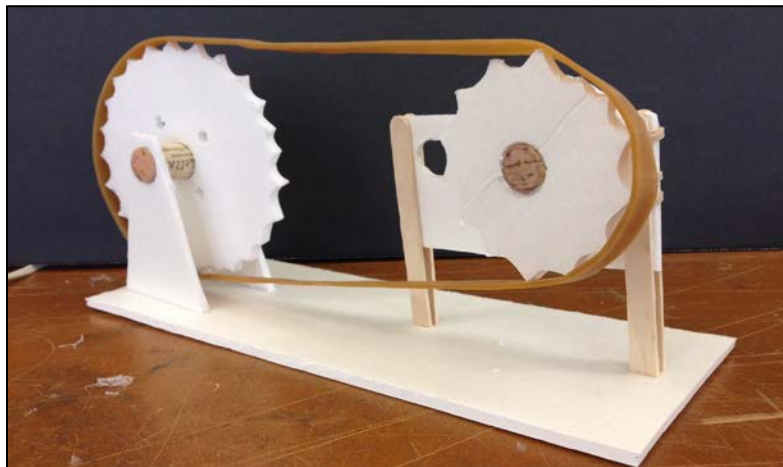

Figure 2 Generic Motorcycle Concept

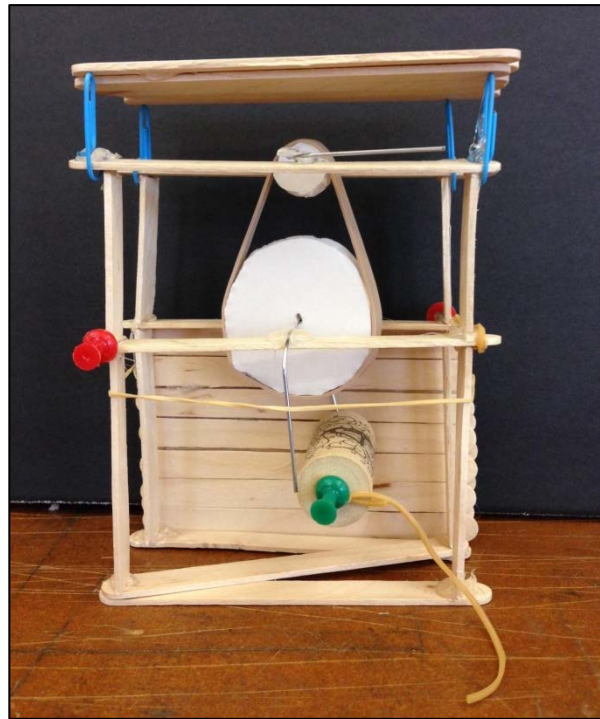

Figure 3 Upright Sprocket Concept

Lastly, ideas were generated for the fixture frame, which houses the testing platform. For the frame however, the sponsor requested the use of an existing 8020 aluminum extrusion table and aluminum plate tabletop. The structure of the frame was then limited to the dimensions of the table: 48" in length, 30" in width, and 34" in height. The table supports an aluminum plate tabletop that measures 48" x 30" x 1". Left for us to consider was how to shield the user from the dangerous testing platform by means of an enclosure.

To keep in line with the sponsor's request to use 8020, a removable aluminum enclosure would best meet the needs of the project. The enclosure could attach to the existing table using 8020 designed latches, and the enclosure would have polycarbonate panels slid into the extrusion slots, in order to provide impact resistant shielding and allow the user to observe the system during testing. The sponsor encouraged the use of such an enclosure, in order to use as many existing 8020 parts as possible. Figure 4 shows a similar system currently used at Quatro Composites for one of their other test fixtures.



Figure 4 Polycarbonate and Aluminum Extrusion Enclosure

3.1.2 Electric Motor Concept

The type of electric motor that the system would use was considered next and was a critical decision, since it would power the entire sprocket and chain system. Motor selection was determined by the amount of power needed to drive the system, as well as the speed required for the long duration of the wear test. The benefits of different motor types were considered.

3.1.2a Power

The motor that would be used would need to run on a typical household wall outlet. Therefore, the selection of the motor was narrowed down to standard single-phase induction AC motors that run on 110 volts and 15 amp power sources. In order to determine the horsepower desired for the motor, calculations based on torque and desired speed (revolutions per minute) were made. Also, due to the power constraints, it was found that the motor would ideally operate at a maximum of 1.75 horsepower through an ordinary outlet delivering 15 amps of

current and 125 volts. According to the National Electrical Manufacturers Association (NEMA), electrical motors constructed for the power range of one to four horsepower must have a minimum nominal efficiency of 78.8%. Therefore, in reality a 1.75 horsepower motor would have an operating power closer to 1.34 horsepower due to losses found in the power source, wiring, etc.

3.1.2b Speed

The maximum speed of single-phase induction motors running on 110 volts is 3600 revolutions per minute (RPM). To keep the motor from overheating, the motor would have to operate at its rated speed, which would be in the range of 2850-3450 RPM depending on the manufacturer. Motorcycle sprockets take approximately 15,000-20,000 miles of run time to produce significantly noticeable wear. Running the motor at this speed would require several days to complete one test. Therefore, the use of forced chain tensioning would need to be introduced to the system to accelerate the process.

3.1.2c Motor Induction Types

When conducting research, different AC induction motor types were considered. These types were split-phase, capacitor-start/capacitor-run, and capacitor-start/induction-run. Table 3 displays the advantages and disadvantages of each type of motor. The cost of each type, the efficiency and the currents and torques of each were evaluated and weighed when making the final decision.

It was determined that a capacitor-start/induction-run motor would best serve the needs of the project. The split-phase motor option, although simplistic and inexpensive, was the first option discarded due to its inferior performance statistics that would not suffice for this application. The capacitor-start/capacitor-run motor and capacitor-start/induction-run motors were very similar, but it was decided that the capacitor-start/capacitor-run motor was more expensive and provided no extra benefits than the capacitor-start/induction-run motor. The main difference between the two was that the induction-run motor disconnects from the start winding and capacitor when the motor reaches about 75% of the rated speed, while the capacitor-run motor keeps the capacitor connection so that it can still provide a high amount of torque at higher RPM. Because the system would speed up to a constant angular velocity, the torque would only be needed at the start-up of chain acceleration and would be very minimal once the motor reached rated speed. The capacitor-start/induction-run motor fulfilled these desired specifications.

Table 3 Motor Type Comparison

Motor Type	Advantages	Disadvantages
Split-phase	Simple	Limited performance
		Develops high starting currents
	Inexpensive	Difficult thermal protection
		Very low starting torque
Capacitor-start/Capacitor-run	High starting torque	Expensive
	Lower full-load currents	
	High efficiency	
	Operates at lower temperatures	
Capacitor-start/Induction-run	High starting torque	Expensive
	Low starting current	
	High efficiency	
	Reliable thermal protection	
	Ability to run high cycle rates	

3.1.3 Chain Tensioning Concept

The wear of chain sprockets is determined by two main factors, the rotational speed of the sprocket and the tension in the chain. Sprocket speed and chain tension contribute to the size of the contact forces at the interface between the sprocket's teeth and the rollers in the chain. With larger contact forces the effect of individual wear mechanisms such as abrasion, adhesion, fretting, and contact fatigue will be increased, resulting in a more rapid rate of wear. The natural wear of a motorcycle sprocket under typical use is a lengthy process. Additionally, sprocket wear in motorcycles is driven by contact forces from the chain tension created by accelerating the mass of the bike-rider system. In order for the testing machine to generate comparable sprocket wear over a relatively short test period, and operate at a constant RPM, the wear rate of the sprockets must be increased without accelerating, and preferably without introducing a force to resist the rotation of the wheel because this would likely generate large amounts of heat. Tensioning the chain was determined to be the preferred way to increase this wear without inducing some sort of resistive load. The following concepts were considered and evaluated as ways to accomplishing this.

3.1.3a Spring Force

The use of a coil spring to tension the chain was considered. Tension would be created by using the spring to apply a force on the axle carrying the motorcycle hub and test sprocket, moving it away from the driving sprocket on the motor shaft. This arrangement would take up any slack in the chain and create a desired tension dependent on the displacement of the spring. A spring offered several advantages including simplicity, low cost, the ability to carry large loads and generate high tensions, and the convenience of being able to vary the tension as desired by setting spring displacement.

Despite its clear advantages, a spring has one critical shortcoming in the context

of a long term wear testing situation. During the life of a sprocket the chain experiences wear as well. The bushings and pins in the chain wear on one another which causes the entire chain to lengthen over time. Lengthening of the chain would allow a spring that was set to a specific displacement to move back towards its unsprung length, causing the force exerted by the spring to fall over the duration of a test. This is not acceptable because for the results of a wear test on one sprocket to be comparable to those on another sprocket, the chain tension during each test must be held constant and independent of the overall chain length.

3.1.3b Hydraulic Actuator

A hydraulic actuator will provide many of a spring's advantages, and with the addition of a control system, also allow for constant force to be maintained over the course of a test. However, a hydraulic system requires many components, including a pump, high pressure lines for fluid, valving, an accumulator, and in the case of the control system a load cell and micro-controller. All of these parts will increase the cost, complexity, and weight of the final testing machine.

3.1.3c Pneumatic Actuator

A pneumatic actuator with a control system shares the advantages and disadvantages of the hydraulic system. There is one additional and unique disadvantage to a pneumatic system, the need for a source of high pressure air. This requirement either limits the locations where the testing machine can be used to those with pressurized air lines already in place, or encumbers the machine with a heavy tank of compressed gas.

3.1.3d Electro-mechanical Actuators

Several types of linear, electro-mechanical actuators were considered including rack and pinion, lead screw, ball screw and roller screw actuators. These linear actuators are desirable because they were able to provide constant force application with the use of a load cell and accompanying control system. Additionally, with an actuator capable of running off of a 110 volt power source like the electric motor driving the chain, there would be no need for a bulky reservoir of compressed air, or a complex hydraulic system.

The screw type actuators are suited to the job of reliably generating the type of force required to tension the motorcycle chain. However, like the other actuators, they require a controller and load cell designed into the testing machine to provide the actuator with force feedback. In addition, a stable control system would need to be designed and tested to run on the controller. Implementing a control system for an actuator would add to the complexity of the design process, and extend the

time period needed to fabricate the machine. Furthermore, the significant current likely to be drawn by a 1.5 horsepower motor would remove the option of using relatively inexpensive microcontrollers designed for hobbyists and instead require the use of a more expensive industrial controller.

3.1.3e Gravitational Force

The final concept considered was the use of suspended weight to tension the chain. A weight, or series of weights, would be suspended on a cable which would transmit tension to the axle holding the motorcycle hub and test sprocket, forcing it away from the driving sprocket on the motor shaft and tensioning the chain. As the chain lengthens during testing the weight would be lowered slightly as the axle carrying the hub moves inside a slot to account for the added length of the chain. The force applied by the weight, and consequently the tension on the chain, would remain constant. Using gravity provides a simple, inexpensive, and very reliable method to maintain a constant tension on the chain which is independent of changes in the chain's length.

3.1.4 Wear Measurement Concept

Several methods were considered in order to determine the best way to measure the sprocket wear generated by the machine. The following physical, optical, and digital measurement methods were explored and their effectiveness and ease assessed.

3.1.4a Water Displacement

The water displacement method could be employed, using a line to suspend the sprocket under water, while using an electric balance to measure the increase in weight. The sprocket could be weighed before and after to determine volume lost as a consequence of the wear test. This method is a standard method used to find volume displaced, and when done correctly can be as accurate as .5% while being easy to use, inexpensive, and relatively clean. However, it is less straight forward than other methods and can be cumbersome to setup and execute properly.

3.1.4b Dimension Measurement Device

Using a general purpose dimensional measurement device, like the SmartScope Flash, could measure tooth wear. The SmartScope can trace the edge of a few sprocket teeth and the resulting line plotted to calculate area lost. The data can also be imported and manipulated in a CAD program to generate a solid model to calculate volume lost. The SmartScope can give accurate results at higher resolutions, however, with the downfall of being expensive and difficult to use. Additionally, for careful and repeatable measurements a locating jig would mostly likely need to be made.

3.1.4c Image Processing Software

Image processing software, like ImageJ can be used to accurately measure area lost with high resolution. However, this method requires that careful and precise photographs be taken of each sprocket before and after the test. Also, it can be challenging to navigate the program's user interface to make the measurements.

3.1.4d Digital Mass Measurement

Using a digital mass balance, the mass of the sprocket before and after the test can be measured. The balance is inexpensive and easy to use, while offering reasonable resolution of 0.1 g.

3.2 Final Concepts Selected

By use of weighted decision matrices and evaluation of how well concepts fulfill the needs and requirements of the project, the final concepts of each subsystem were selected. The decision matrices and their explanations are presented in this section.

3.2.1 Test Platform and Fixture Frame

The generic motorcycle chain and sprocket set-up was chosen, with the sprockets and a chain in a horizontal fashion would be used in the final design. This method can interface easily with the existing table and tabletop, and allow for chain tensioning components to be located underneath. All frame components will be made of 8020 aluminum extrusions and polycarbonate panels will be used to offer impact resistance.

3.2.2 Motor

The best motor for the system was determined to be the Grizzly G2535 Single-Phase Motor. This 1.5 horsepower motor runs on 110 volt power and is rated to run at 3450 RPM. It is a capacitor-start/induction-run motor made for wide industrial use. Other specifications include a 0.75" diameter shaft, which can be coupled to the system's drive shaft for direct power input.

Due to the low amount of torque that would be required to drive the actual system, the focus was on selecting a motor that could perform at high RPM for a long duration of time, without the occurrence of overheating or other possible motor breakdowns. The following decision matrix shows the criteria evaluated that led to the decision to use the Grizzly G2535.

Table 4 Criteria Definitions for Motor Selection

Criteria	
1	Cost
2	Horsepower
3	Weight
4	Starting Torque
5	Thermal Protection
6	Speed
7	Safety - Possible hazards based on enclosure
8	Size

Table 5 Decision Matrix for Motor Selection

	Weight	[Datum] Grizzly G2905	Weighted Score	Baldor L1313T	Weighted Score	Grizzly G2908	Weighted Score	Dayton 6K321	Weighted Score	Grizzly G2535	Weighted Score
1	1	0	0	-1	-1	-1	-1	-1	-1	-1	-1
2	3	0	0	1	3	1	3	-1	-3	1	3
3	1	0	0	-1	-1	0	0	1	1	0	0
4	3	0	0	0	0	1	3	1	3	1	3
5	5	0	0	0	0	1	5	0	0	1	5
6	4	0	0	1	4	0	0	-1	-4	1	4
7	5	0	0	0	0	1	5	0	0	1	5
8	1	0	0	-1	-1	0	0	0	0	0	0
Weighted Total			0		4		15		-4		19

3.2.3 Chain Tension

It was decided that best method for chain tension would be the gravitational force method. The selection of a system for tensioning the chain was carried out by evaluating the ability of each of the proposed methods to satisfy a set of weighted design considerations. This was accomplished by the weighted decision matrix. Using gravity to generate chain tension via a suspended weight was the strongest concept evaluated and was selected for use in the final machine design. However, after the conceptual design review, the sponsor selected pneumatic actuation as the preferred method. This was implemented into the final design.

Table 6 Decision Matrix for Chain Tension

	Weight	Pure Mechanical			Fluid-mechanical Actuators			Electro-mechanical Actuators							
		Coil Spring	Weighted Score	Gravity/Suspended Weight	Weighted Score	Pneumatic	Weighted Score	Hydraulic	Weighted Score	Ball Screw	Weighted Score	Roller Screw	Weighted Score	Rack and Pinion	Weighted Score
Ability to apply constant force	5	0	0	1	5	1	5	1	5	1	5	1	5	1	5
Load Capacity	3	0	0	1	3	1	3	1	3	1	3	1	3	0	0
Reliability	3	0	0	0	0	0	0	0	0	1	3	1	3	0	0
Weight	2	0	0	-1	-2	0	0	-1	-2	-1	-2	-1	-2	-1	-2
Simplicity	2	0	0	0	0	-1	-2	-1	-2	-1	-2	-1	-2	-1	-2
Cost	2	0	0	1	2	-1	-2	-1	-2	-1	-2	-1	-2	-1	-2
Variability	4	0	0	1	4	1	4	1	4	-1	-4	-1	-4	-1	-4
Weighted Total			0		12		8		6		1		1		-5

3.2.4 Wear Measurement

It was determined that the best method for measuring sprocket wear would be the digital mass measurement. With this method, a wear rate can be calculated using the mass loss per a certain number of revolutions and can be plotted as a function of chain tensioning force. While other methods may be used to compare results, the digital mass balance measurement will be primarily used for this project. Table 7 shows that the digital mass balance method is just as accurate as its counterparts, but is less expensive and easier to use. Therefore, this will be the method used in the final design.

Table 7 Weighted Decision Matrix for Wear Measurement

	Weight	SmartScope Flash 250	Weighted Score	Chemistry Balance	Weighted Score	Water Displacement Method	Weighted Score	Photograph + Image Processing Software	Weighted Score	Physical Measurement (Calipers)	Weighted Score
Can measure $\geq 3\%$ Wear	5	1	5	0	0	0	0	1	5	-1	-5
Can be accurate to 5%	4	1	4	1	4	0	0	1	4	-1	-4
Can be easy to use	3	-1	-3	1	3	0	0	-1	-3	1	3
Inexpensive	4	-1	-4	1	4	0	0	1	4	0	0
Clean	2	1	2	1	2	0	0	1	2	1	2
Weighted Total			4		13		0		12		-4

3.2.5 Final Concepts Combined

The drawing in Figure 5 represents the combination of subsystem concepts. In this design, the selected 1.5 horsepower capacitor-start/induction-run AC motor is coupled to a drive shaft. A 1:1 sprocket ratio is used to maintain rated speed, and the test sprocket is mounted to a motorcycle hub. The hub is mounted onto the chain tensioning system, by means of a carriage mount that slides on rails. This chain tensioning system consists of a steel cable attached to the carriage that runs over a pulley and through a hole in the aluminum tabletop. Under this table, adjustable weights are included to change the amount of tension desired depending on the specifications of the sprocket test.

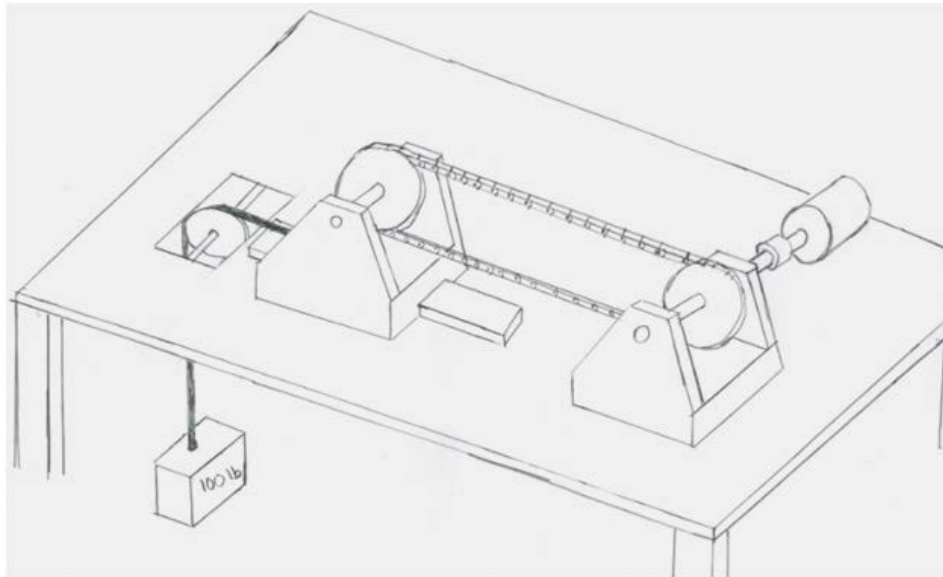

Figure 5 Final Concepts Combined

3.3 Final Concepts Approved

At the conceptual design review with the sponsor, all final concepts were approved except the gravitational force chain tensioning method. The sponsor instead asked the team to use an existing pneumatic actuator. The final design included the details of the new chain tensioning system and how it was integrated with the other selected concepts.

4. Final Design

Once the final concepts were approved by the sponsor, these concepts were combined to create and model the fixture's final design. An overall design description is presented and then the details of each subsystem and its components are explained. Lastly, supporting analysis and the final design cost are presented.

4.1 Overall Design Description

The sprocket wear testing machine consists of a mainframe constructed from aluminum t-slot extrusion mounted on rolling caster wheels, with a one inch thick aluminum tabletop plate. All mechanical components and mounts of the testing system are affixed to the tabletop, while electrical and pneumatic lines enter the enclosed testing area via cutouts in the plate. The testing area is enclosed by a separate t-slot extrusion frame featuring integral, transparent polycarbonate panel shielding. This allows the machinery to be isolated, yet visible, reducing hazards. The enclosure is joined to the tabletop by hinges, granting easy access to the chain drive inside.

Within the enclosure there is a motorcycle chain drive system mounted to the tabletop. A 110 volt single phase electric motor is coupled to the main drive shaft. The drive shaft rotates on a pair of outboard bearings, one located on each end, and features a key-way used to mount the driving sprocket. The other end of the drivetrain consists of a motorcycle hub onto which the test sprocket is mounted, and a roller chain which transmits power between the driven and driving sprockets. The hub is mounted to a pneumatic linear actuator which moves the hub, increasing the distance between sprockets, which compensates for chain elongation and maintains chain tension for the duration of tests.

The testing machine is operated via a motor power switch, a knob to regulate air pressure to the actuator, and a button to open or close the valve feeding the actuator. The pressure in the air system is monitored by back-up analog gauge located on the pneumatic regulator.

A labeled close-up of the drivetrain is shown in Figure 6, and a labeled overall fixture design is shown in Figure 7.

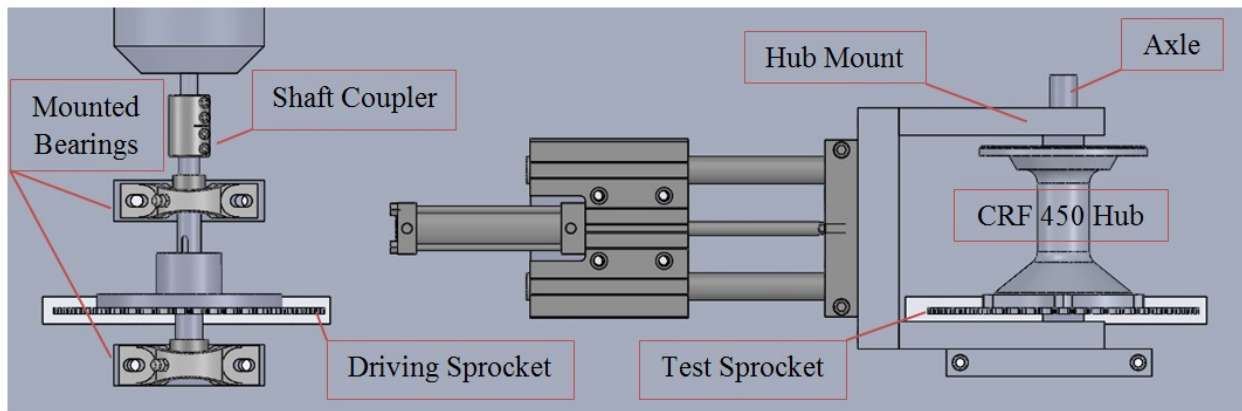

Figure 6 Labeled Drive Train Design

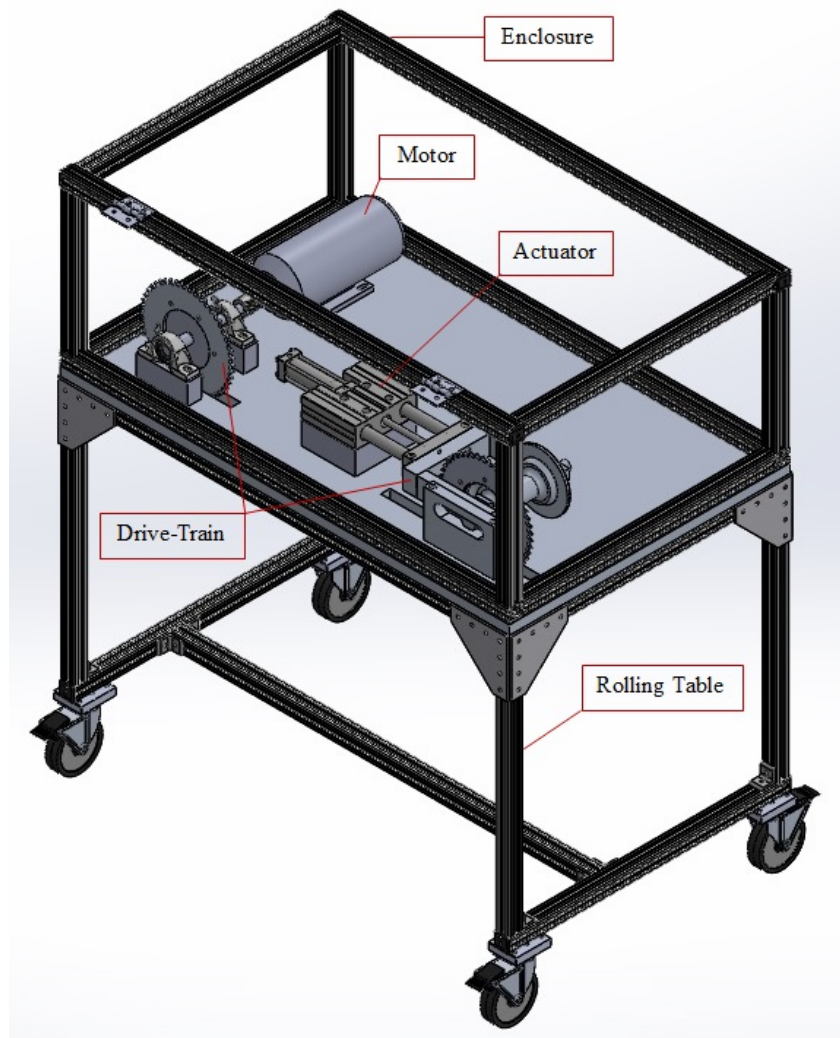

Figure 7 Overall Labeled Fixture Design

4.1.1 Frame and Table Design Details

The testing machine's mainframe is constructed using 1515 series 80/20 Inc., t-slot aluminum extrusions with a 1.5" x 1.5" cross-section. These members are joined using brackets, fasteners, and other associated hardware. With the extrusions, a table measuring 48" in length, 30" in width, and 34" in height is constructed to support an aluminum plate tabletop that measures 48" x 30" x 1" and is attached to the frame by socket head cap screws at each corner. On this plate the chain drive, pneumatic system, and enclosure reside. Bolt holes are drilled into the plate to fasten motor supports, drive shaft and bearing mounts, a pneumatic actuator, the actuator's pressure regulator, and the hub assembly mounting brackets. Similarly, electrical and air lines enter the enclosed testing area through holes in the plate. Lastly, larger slots are drilled on either end of the table to accommodate the chain, which rotates through the table.

4.1.2 Drivetrain Design Details

At the core of the drivetrain is a motorcycle chain drive including two 48 tooth motorcycle sprockets, a 520 motorcycle roller chain, and a CRF450r motorcycle hub. The chain drive receives power from the 1.5 horsepower electric motor, The main drive shaft features three distinct shoulder diameters. The shaft is $\frac{3}{4}$ " in diameter at the coupler, $\frac{7}{8}$ " in diameter at the driving sprocket, and 1" at the end opposite of the motor. The drive shaft is supported with two bearings located on either side of the sprocket. The shaft is located by the $\frac{3}{4}$ " bore bearing and the $\frac{3}{4}$ " to $\frac{7}{8}$ " step in diameter. The other bearing has a 1" bore and does not locate the shaft.

The driving sprocket is mounted to a sprocket holder which is located on the drive shaft by the $\frac{7}{8}$ " to 1" step and held by a keyway. At the other end of the 520 motorcycle chain is the test sprocket which is bolted to a rear hub from an actual CRF450r motorcycle. The hub itself is mounted to a linear actuator and guided by a slotted bracket fixed to the table top. The slot allows the hub to move forward and backward relative to the drive shaft, varying the distance between sprockets. This configuration allows for up to 4" of linear travel parallel to the table in order to remove slack in the chain that arises due to the chain's elongation during extended test periods. Additionally, the linear pneumatic actuator allows a set amount of chain tension to be maintained, removing undesirable variables from testing. To lower the center of gravity of the drivetrain, and remove the need for spacer blocks to elevate the motor, the chain drive protrudes through a channel cut into the tabletop.

4.1.3 Electro-mechanical Design Details

The system is driven by a single-phase capacitor-start/induction-run electric motor held on one end of the table in its supports. An electric switch is used to turn the motor on and off, and can run up to an operating speed of 3450 RPM. To power the motor the user must flip the on/off switch and plug the motor directly in and out of any 110 Volt outlet. Safety shut off switches are built into the system through the main frame. A button is placed within the test area that allows the test to run only when the enclosure is fully closed over the testing platform. A red stop button is implemented onto the structure and wired to the electrical components of the design.

4.1.4 Linear Motion Design Details

A pneumatic actuator is secured to the tabletop using socket head cap screws. On one end of the actuator is a rectangular platform onto which the hub swing arm bracket is attached. The actuator is powered using industry standard compressed air between 90 and 120 psi, with a regulator setting the operating pressure at 20 psi less than what is available. This way, during peak compressed air usage, the testing system will not be deprived of the needed air. Standard air fittings will allow most shop air hoses to attach easily to the system.

4.1.5 Safety Design Details

The removable enclosure, attached to the tabletop, is the primary safety design feature implemented to protect the user from the dangerous testing platform. The enclosure frame is made of 1515 series 80/20 Inc., t-slot aluminum extrusions with a 1.5" x 1.5" cross-section. In the t-slot of the frame, polycarbonate up to ¼" thick can be installed and secured using rubber seals.

Makrolon GP polycarbonate sheet has been selected for several reasons as the panels that comprise the enclosure. This material is used in manufacturing environments for protection against high velocity impacts, especially as machine guards. Polycarbonate is also used as noise reducing shields and transparent walls where visibility within a structure is important. The enclosure will be supplemented with an electronic sensor switch that will only allow power to the system when the enclosure is secured to the table.

Further safety considerations will take place once the structure is built and operational. For example, additional sound barriers will be used if the noise level exceeds the specified allowable 80 dB and additional motor cooling will be added if the motor is observed to exceed 212 °F. All electrical work will be done by Campus Health and Safety approved electricians and an exhaustive user guide will be written with safe operation procedures and guidelines.

4.2 Supporting Analysis

The following sections detail the technical analysis that was conducted in order to justify the selection of various components. All components were selected with the intent of satisfying the engineering specifications listed in Table 1 of section 1.2.

4.2.1 Motor Selection

The selection of the motor is critical, as it will be the driving force of the testing machine. As seen in Table 1.2, the motor must run on a 110 volt power supply. Regulations for household power outlets regulate the amount of power allowed to be consumed. The average 110 volt power supply has a maximum current setting of 15 amps. Since power is equal to voltage times current, the calculation for the ideal power coming from these outlets would result in 1650 Watts. Minor losses between the power source and the motor, such as electrical resistance, must also be taken into account, which decreases the load voltage.

Single-phase motors have power losses within their builds as well. The average electric motor sees efficiency ranges anywhere between 60-70%. Using the best-case scenario of 70% efficiency yields a maximum continuous output power of 1155 watts. This is equivalent to 1.548 horsepower. For worst-case scenario, 60% efficiency, the delivered

output power would be approximately 1.33 horsepower. These formulas used in performing the calculation can be seen below:

$$\text{Horsepower} = \text{Power} * \text{Efficiency} * \frac{[1 \text{ HP}]}{[746 \text{ W}]}$$

Where,

$$\text{Power} = \text{Voltage} * \text{Current}$$

Therefore, it was decided that 1.5 horsepower would be the ideal power of the motor, due to its ability to essentially operate at peak levels with our 110 volt power source.

The next aspect to consider for motor selection was its operating speed. Single-phase motors come with two different speeds: 1800 and 3600 RPM. Once again, referring to the efficiency ratings of these motors, their continuous operating speeds are 1725 and 3450 RPM, respectively. In order to get an idea for the amount of time needed to perform our test, the following equations were used:

$$\frac{\text{Mileage at Wear}}{\text{Sprocket Circumference}} = \text{Total Revolutions}$$

$$\frac{\text{Total Revolutions}}{\text{Operating Speed}} = \text{Test Time}$$

Having a 1.5 horsepower motor, operating at 3450 RPM, equates to a constant torque 2.283 lb-ft at operating speed. This is not very high, yet effective for our system at operating speed due to the little amount of torque needed to drive the sprocket at constant velocity. A more detailed version of this analysis can be found in Appendix B.

4.2.2 Bearing Selection

Due to the high operating speed of the proposed chain drive (3000 RPM) as well as the presence of applied loads from the pneumatic actuator bearings must be chosen carefully to satisfy the engineering specification which dictates a 3000 hour life for rotational parts. A load-life fatigue analysis was conducted to justify the bearings selected for the drivetrain.

The actual radial loads for the fatigue analysis were first computed for a maximum loading case. For the pneumatic actuator the maximum loading condition occurs at an air pressure of 150 psi, as this was the lowest maximum pressure rating of any component in the system.

The actuator force generated by a pressure of 150 psi was found by the following

calculation:

$$Force = Piston\ Surface\ Area \times Cylinder\ Pressure$$

The 220 lb actuator load is exerted on both sides of the chain drive. The design intentionally arranges the chain drive components in order to make all bearing support forces symmetrical and eliminate moments which would cause binding and deflection between the bearing races. This resulted in the load being evenly shared between the two bearings supporting the drive shaft, and similarly on the other side of the chain drive, shared evenly between the three bearings located inside the hub.

The theoretical maximum radial loads that would allow the bearings to satisfy the engineering specifications for a 3000 hour life at 3000 RPM with an overall reliability of 95% were determined by the following process,

Bearing Load-Life analysis was conducted using the following method implemented within a spreadsheet.

For rolling contact ball bearings,

$$C_{10} = C_A \left(\frac{L_D}{A_R L_{10}} \right)^{\frac{1}{3}}$$

which is re-arranged giving,

$$C_A = \frac{C_{10}}{\left(\frac{L_D}{A_R L_{10}} \right)^{\frac{1}{3}}}$$

where,

L_{10} = The rated life in number of revolutions (typically 10^6)

L_D = The desired design life of the bearing in revolutions

C_{10} = The rated radial load at the rated life

C_A = The allowable radial load for the design life

$A_R = x_0 - (\theta - x_0)(1 - R)^b$ = The reliability factor for $R \geq 0.90$

for which,

R = the desired individual reliability

and,

$x_0, \theta,$ and b are given by the bearing manufacturer

This analysis allowed the fatigue factor of safety to be computed for a given design life, design load, and reliability;

$$F.S. = \frac{L_A}{L_D} = \frac{\text{Allowable load}}{\text{Design Load}}$$

and an overall reliability to be calculated thusly,

$$\text{Overall Reliability} = R^N$$

where,

$$R = \text{the desired individual reliability}$$

$$N = \text{the number of bearings in the system}$$

Note: Axial loading on the bearings in the design was negligible, thus no equivalent radial loads were required for analysis.

The result of the load-life analysis, namely the fatigue factor of safety (a ratio of the allowable load to the actual load) was used to judge whether or not the bearings selected were acceptable for the task.

Table 8 Results of Bearing Load-Life Analysis

Bearing Location	Bearing #	Design Life (Hours)	Design Speed (RPM)	Allowable Load (lbs)	Fatigue Factor of Safety
Driveshaft	6361K37	3000	3000	243	2.8
	6361K34	3000	3000	198	2.2
Motorcycle Hub	6905-RS/2RS	3000	3000	121	2.1

It is clear from the fatigue factors of safety that all 5 bearings utilized in the drivetrain will satisfy the engineering specifications

4.2.3 Safety Selection

According to Sheffield Plastics Inc., the makers of MAKROLON GP polycarbonate sheet, a 1/8" thick panel has an impact strength rating in units of energy lost per unit of thickness of 60 ft-lb/in. This means a 1/8" thick polycarbonate panel can absorb 7.5 ft-lbs of energy without failure. In the case of the 1.5" x 1.5" aluminum t-slot extrusions being used for the enclosure, polycarbonate panels 1/4" inches thick can be slid into the slots and safely absorb 15 ft-lbs of energy.

In analyzing the effectiveness of the polycarbonate to shield the user from component failure, the type of collision that would occur between a drivetrain component and side panel had to be determined. Partially inelastic collisions are the most common type of collisions, and in this case kinetic energy is lost through friction, sound and heat.

For simplicity, we began with the case of a perfectly inelastic collision, where the maximum amount of kinetic energy of the system would be lost. In this case, the colliding particles would stick together, meaning the component impacting the polycarbonate would not bounce off.

A potential failure is that of the chain snapping and possibly impacting the side panel. Because the chain is mounted and installed by the operator, human error is likely to cause improper installation. In this case, the pin holding together the chain can become loose and cause one end of the chain to whip towards the side panel. Using the known impact energy of the polycarbonate, the mass of individual chain links (.03 slugs/link), and the mass of the structure as a whole, it was determined that 1 chain link could safely impact the polycarbonate at an impact velocity of 20 mph. To determine this, the conservation of momentum for the collision was used to find the kinetic energy lost per the collision.

$$\text{Kinetic Energy} = KE = \frac{1}{2} m v^2$$

$$\text{Momentum} = mv$$

Conservation of momentum for an inelastic collision

$$m_1 v_1 = (m_1 + m_2) v_2$$

Fraction of energy lost

$$\frac{KE_i - KE_f}{KE_i} = \frac{m_2}{m_1 + m_2}$$

Taking a closer look at the dynamics of the sprocket and chain, the maximum speed of the chain was determined. Where N is the number of sprocket teeth, p is the chain pitch in inches, and n is the sprocket speed in revolutions per minute, the maximum exit velocity of the chain, as a function of pitch diameter, D, is given by:

$$v_{max} = \frac{\pi D n}{12} = \frac{\pi n p}{12 \sin \frac{\gamma}{2}} = \frac{\pi n p}{12 \sin \frac{180}{N}}$$

With a speed of 3000 RPM, a chain pitch $\frac{5}{8}$ “, and a sprocket with 48 teeth, the maximum chain velocity is 7505 ft/min or 85 mph. In the event of a catastrophic incident in which the chain failed at this speed, and had enough kinetic energy to whip towards and impact the polycarbonate, the impact force could be quite high. But because the motion and trajectory of the chain is difficult to predict, the type of impact and the energy of impact,

is unknown. Therefore, proper installation of the chain is paramount, and the safe operation of the testing fixture is only permitted with the proper installation of the chain by a professional.

Using the known impact energy and the sprocket mass, it was determined that in the event of a catastrophic failure, the heaviest test sprocket, made of steel, with a mass of 930 g could safely impact the polycarbonate at an impact velocity of 14 mph. Before this could occur, the chain would have to snap and the 6 bolts holding the sprocket to the hub would have to fail. Only then would the sprocket fly across the enclosure and impact the side panel. This occurrence is highly unlikely. However, careful sprocket installation can ensure that accidents and loose parts within the test platform are avoided.

Additionally, at such high chain speeds, the machine must not be able to turn on unless the door of the fixture is closed and locked in place. The safe operation of the machine is therefore only permitted with the inclusion of a switch that will disable power the moment the door is unlocked.

4.3 Maintenance and Repair

A complete employment operation and maintenance manual is included in Appendix F. This document includes a machine overview, component breakdown, instructions for safe machine operation and detailed recommended machine maintenance.

4.4 Cost Analysis

Table 9 shows the cost total for the wear testing machine. The total cost column reflects the cost of the fixture if every component were outsourced. On the right is a corrected total taking into account donated parts. Approximately \$590 was saved due to the donation of the pneumatic actuator, listed under the linear motion subsystem. Another donated component which lowered the cost estimate substantially is the aluminum 8020 extrusion table, with rolling casters and a 1” aluminum tabletop. This component is under the structure subsystem and allows for an additional \$679.10 in estimated savings. A Bill of Materials, showing the pricing and sourcing of each component, is found in Appendix E.

Table 9 Cost Analysis

Description	Subsystem	Quantity	Unit Cost (\$)	Total Cost (\$)	Donated (Y or N)	Corrected Cost (\$)	Part Ordered (Y or N)
Aluminum 1.5" x 1.5" 1515 T-Slot Extrusions	Structure	8	\$ 39.31	\$ 314.48	N	\$ 314.48	Y
Aluminum Table Top	Structure	1	\$ 500.00	\$ 500.00	Y	\$ 0.00	Y
45" x 22" x 0.25" Black Polycarbonate Panel	Safety Shielding	1	\$ 150.00	\$ 150.00	N	\$ 150.00	Y
45" x 22" x 0.25" Transparent Polycarbonate Panel	Safety Shielding	1	\$ 150.00	\$ 150.00	N	\$ 150.00	Y
45" x 28" x 0.25" Transparent Polycarbonate Panel	Safety Shielding	1	\$ 150.00	\$ 150.00	N	\$ 150.00	Y
28" x 22" x 0.25" Transparent Polycarbonate Panel	Safety Shielding	2	\$ 84.60	\$ 169.20	N	\$ 169.20	Y
Baldor L3513M 1.5 HP Electric Motor	Electromechanical	1	\$ 187.53	\$ 187.53	N	\$ 187.53	Y
5/8" to 3/4" Shaft Coupler	Drivetrain	1	\$ 53.81	\$ 53.81	N	\$ 53.81	Y
9" Stepped Steel Drive Shaft	Drivetrain	1	\$ 24.45	\$ 24.45	N	\$ 24.45	Y
6061 Aluminum Stock for Driving Sprocket Mount	Drivetrain	1	\$ 45.56	\$ 45.56	N	\$ 45.56	Y
6061 Aluminum Stock for Bearing Mount Block	Drivetrain	1	\$ 27.57	\$ 27.57	N	\$ 27.57	Y
Cast Iron Base-Mounted Ball Bearing, 1" Bore	Drivetrain	1	\$ 39.68	\$ 39.68	N	\$ 39.68	Y
Cast Iron Base-Mounted Ball Bearing, 3/4" Bore	Drivetrain	1	\$ 43.16	\$ 43.16	N	\$ 43.16	Y
Steel Machine Key, 0.25" Square Size	Drivetrain	1	\$ 10.93	\$ 10.93	N	\$ 10.93	Y
6061 Aluminum Stock For Actuator Riser Block	Linear Motion	1	\$ 67.32	\$ 67.32	N	\$ 67.32	Y
6061 Aluminum Stock for Hub Mount	Drivetrain	1	\$ 22.16	\$ 22.16	N	\$ 22.16	Y
6061 Aluminum Stock for Hub Mount Arm	Drivetrain	2	\$ 17.52	\$ 35.04	N	\$ 35.04	Y
6061 Aluminum Stock for Hub Mount Guide Slot	Drivetrain	1	\$ 44.36	\$ 44.36	N	\$ 44.36	Y
3-Way Air Directional Control Valve	Linear Motion	1	\$ 81.88	\$ 81.88	N	\$ 81.88	Y

Description	Subsystem	Quantity	Unit Cost (\$)	Total Cost (\$)	Donated (Y or N)	Corrected Cost (\$)	Part Ordered (Y or N)
Pneumatic Linear Actuator	Linear Motion	1	\$ 500.00	\$ 500.00	Y	\$ 0.00	Y
Air Pressure Regulator	Linear Motion	1	\$ 90.00	\$ 90.00	Y	\$ 0.00	Y
CR450 Rear Motorcycle Hub	Drivetrain	1	\$ 40.00	\$ 40.00	N	\$ 40.00	Y
CR450 Rear Motorcycle Axle, Nut, & Washer	Drivetrain	1	\$ 30.05	\$ 30.05	N	\$ 30.05	Y
CR450 Rear Motorcycle Rear Hub Bearings & Seals	Drivetrain	1	\$ 14.99	\$ 14.99	N	\$ 14.99	Y
CR450 Rear Motorcycle Hub Bearing Retainer & Spacer	Drivetrain	1	\$ 44.78	\$ 44.78	N	\$ 44.78	Y
Motorcycle Sprocket Mounting Hardware	Drivetrain	1	\$ 18.79	\$ 18.79	N	\$ 18.79	Y
520 Motorcycle Chain (25 ft)	Drivetrain	1	\$ 115.50	\$ 115.50	N	\$ 115.50	Y
Steel CR450 Sprocket	Drivetrain	1	\$ 29.95	\$ 29.95	N	\$ 29.95	Y
Aluminum CR450 Sprocket	Drivetrain	1	\$ 37.95	\$ 37.95	N	\$ 37.95	Y
Hardware and Miscellaneous Costs				\$ 303.91		\$ 200.00	Y
Sum				\$ 3,343.05		\$ 2,103.58	100%
Original Bid						\$ 2,235.50	
Amount Under Bid (Original Bid – Sum)						\$ 131.92	

5. Product Realization

Once the final design was chosen, the machine manufacturing proceeded according to a proposed manufacturing plan. In this chapter, the actual processes carried out are described in detail, with explanations of deviations from the original final design, and recommendations for future manufacturing.

5.1 Manufacturing Process

The manufacture and assembly of the machine took place in three phases, beginning with the modification of existing pieces, moving on to the fabrication of additional components, and then assembly/installation, safety additions, and electrical wiring. Table 10 show the manufacturing schedule used in order to keep track of the process flow path.

Table 10 Original Manufacturing/Assembly Plan

Task #	Description	Hardware	Tools Required
1	Cut 8020 to length	--	Tape measure, chop saw, grinder, manual mill
2	Assemble table + install casters	(4) Socket Head 3/8-16 x 2 3/4"	Allen wrench, wrench
3	Modify tabletop	--	CNC mill, drill bits, end mills
4	Machine riser blocks and mounts	--	Manual mill, end mill, drill bits
5	Press bearings	--	Hydraulic press
6	Machine keyway into drive shaft	--	Manual lathe/mill, turning tool/endmill
7	Fasten mounts and riser blocks onto tabletop	(4) Hex Bolt 3/8-16 x 8" + washers/nuts, (4) Hex Bolt 5/16-16 x 8" + washers/nuts	Socket/ratchet, wrench
8	Cut polycarbonate to length	--	Measuring tape, table saw
9	Assemble enclosure	(16) 80/20® 3389 Single Tab End Fastener	Allen wrench, Dremel tool
10	Install motor, actuator, hub/axle, guide slot	(4) 5/16 - 16 x 2" + washers/nuts, (4) 3/8-16 x 2" Coarse Flange Hex, (4) Socket Head 5/16 - 16 x 2", (2) Hex Head 5/16 -16 x 2 1/2" + washers	Sockets/ratchets, wrenches
11	Install sprockets, chain	(12) Screw, FLAT (8X31) + washes/nuts, (1 per chain) Masterlink	Dremel tool, allen wrench
12	Install switches, sensors, control knobs	(6) 10-32 x 3/4 Steel Phillips Pan Machine Screw, (8) 8-32 x 1/2" Phillips Pan Head Machine Screw	Phillips/flathead screwdrivers
13	Wiring	(12 ft each) green/white/black 12 gauge braided copper wire, Assorted electrical connectors (Terminals/Splices/Lugs)	Wire cutter/crimpers, Philips screwdriver
14	Install enclosure to table	(4) 80/20® 1/4-20 x 1/2" Bolt Kit + washers, (4) 80/20®10-32 x 1/2" Button Head Socket Cap + nuts/washers	Allen wrenches

5.1.1 Table Modification

Manufacturing began with the modification of the existing rolling table and tabletop that were provided by Quatro Composites. The table in its original state included rolling casters and a set of three shelves. The frame and casters were cleaned and left intact, while all shelves were removed. A control panel was added last.



Figure 8 Table and Tabletop, Before Modifications

Next, the tabletop was modified using a Computer Numerical Control (CNC) machine to create holes and pockets that were needed to mount the drivetrain components. First the tabletop was modeled in SolidWorks, and the facing and drilling features were simulated and the CNC coding language was generated, both in CamWorks. Afterwards, the tabletop was mounted into the Mustang '60 Haas VF-3 machine, shown in Figure 8, and the machine origins and tools were selected.

Due to the large size of the tabletop, three machinists were needed to load and maneuver the tabletop inside the VF-3, and three different machine set-ups were required due to the limitations in x-direction and y-direction travel of the machine.



Figure 9 Loading the Tabletop inside the VF-3

5.1.2 Enclosure

Manufacturing of the enclosure was next and included a combination of 8020 aluminum t-slot extrusions and ¼” polycarbonate panels. The 8020 was ordered in 4-, 6-, and 8-foot lengths, and each member was first roughly cut to within ⅛” of its final dimension with the use of a horizontal band saw. In order to minimize the discrepancies between the connecting pieces, a manual mill was used to face the members to their final size. Lastly, access holes were drilled, the ends were tapped, and the members were connected and fastened.

The enclosure consisted of five polycarbonate panels: four transparent panels for the front/side walls and ceiling and one black panel for the back wall. The panels were cut to the length and width specifications, and the corners were notched in order to make room for the connecting bolts. Following assembly, a hole saw was used to create ventilation through the black polycarbonate panel on the back of the enclosure, with expanded steel mesh covering the holes to prevent foreign objects from entering. In addition, expanded metal mesh was cut, outfitted with edge trim, and mounted to each side of the enclosure to provide additional protection in the event of a chain failure and panel impact.

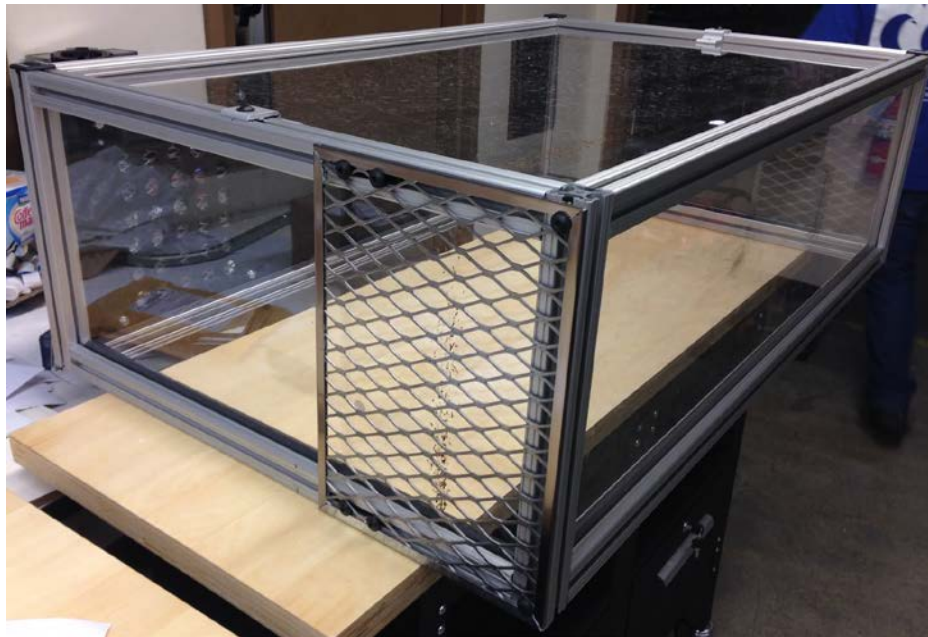

Figure 10 The Assembled Enclosure with Chain Guards

The enclosure was the last element to be secured to the tabletop, and was done so with two hinges on the back. Furthermore, to assist in opening and closing the enclosure, two 40lb air springs were installed on either side, allowing the enclosure to open 30 degrees, granting access to the drivetrain components.

5.1.3 Drivetrain

The second phase of manufacturing included the fabrication of the drive train components and their installation onto the tabletop.

5.1.3a Spacer Blocks

6061 aluminum spacer blocks were made for the two bearing blocks and the actuator. These spacer blocks were necessary to elevate the components from the tabletop surface and keep them in line with the plane of the motor shaft. Spacer blocks were machined using a manual mill, with the blocks being roughly cut with a horizontal bandsaw, before being faced to length, width, and height. Holes were then drilled and the blocks were mounted on to the tabletop platform.

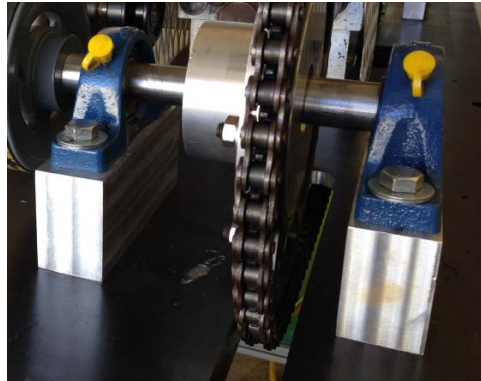

Figure 11 Bearing Spacer Blocks for the Drive Shaft

5.1.3b Drive Shaft

A two-step steel drive shaft was purchased on McMaster-Carr and modified with a manual lathe to include a third step used to locate the sprocket holder. Then, using a manual mill, the sprocket holder keyway was milled, and the shaft was shortened by facing off $\frac{1}{4}$ ".

5.1.3c Sprocket Holder

The sprocket holder was machined from a 7" diameter 6061 aluminum round stock, using the Hass VF-3. It was modeled in SolidWorks, with machining simulation and CNC code generation done in CamWorks. The faces and bosses were milled to precision, and then the drive shaft bore and six bolt holes were drilled. The sprocket holder was machined in two set-ups: a top face and then flipped over to machine the bottom face. The part required the making of custom 'soft jaws' that were used to hold the top of the sprocket holder, in order to accurately machine the bottom.

After the holder was machined, a keyway was needed to mount the holder onto the drive shaft. A custom broach collar was made to fit into the $\frac{7}{8}$ " bore and guide a $\frac{1}{4}$ " keyway broach. With the custom collar, the broach was pressed through using a hydraulic press and was able to accurately cut the keyway. The drive shaft was then cooled in a freezer, the sprocket holder was heated using a propane torch, and the shaft and key were shrink-fitted into the holder.

The steel driving sprocket was then bolted onto the holder. Figure 11 shows the sprocket holder on the left and part of the CamWorks simulation on the right.

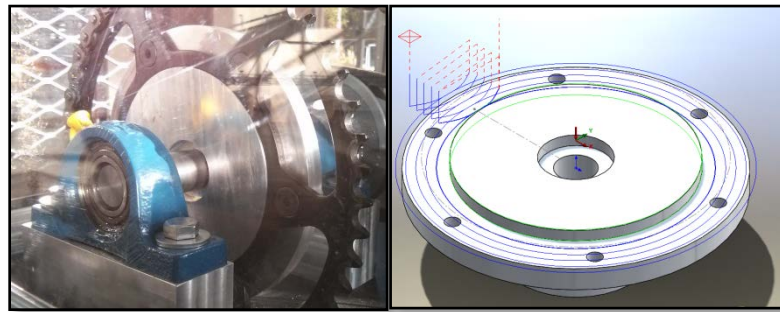

Figure 12 Sprocket Holder

5.1.3d Hub

The hub chosen was a stock CRF450 rear wheel hub, purchased from a used parts dealer. The hub was cleaned before having new bearings and bearing seals pressed in. The first test sprocket was then bolted onto the hub.



Figure 13 CRF 450 Hub

5.1.3e Swingarm

The swingarm components and the axle guide slot were machined last, once the motorcycle axle and axle blocks/nut arrived. The actual axle length and block thicknesses were measured, the CAD machine assembly updated, and the last components sized to allow for the axle to sit securely through the swingarm and in the slot.

First, the swingarm-to-actuator attachment was machined and drilled, using a manual mill. Then, the two arms were milled to length, drilled, and tapped. Most importantly the bore in each of these arms, for the axle to slide through, was made using a precision boring head in order to keep tight tolerances and have a close fit. Lastly, the axle guide slot was faced to length, width, and height, drilled and tapped, and the pocket was milled, all on a manual mill. The swingarm was then assembled and mounted onto the actuator's moving plate.

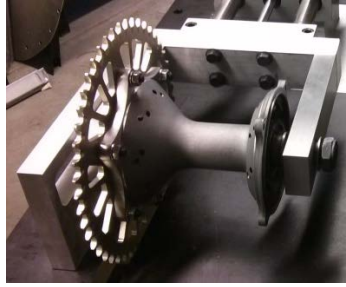

Figure 14 Swingarm with hub/axle Installed

5.1.3f Assembly

With all machining completed, the drivetrain was installed onto the tabletop. The drive shaft was located in its bearings, and the motor was coupled to the shaft before being fastened to the tabletop. With the actuator and swing arm already bolted down, the remaining assembly included fastening the guide slot, and slipping the axle through the swingarm and hub. Lastly, the chain was installed and closed using a masterlink and clip.

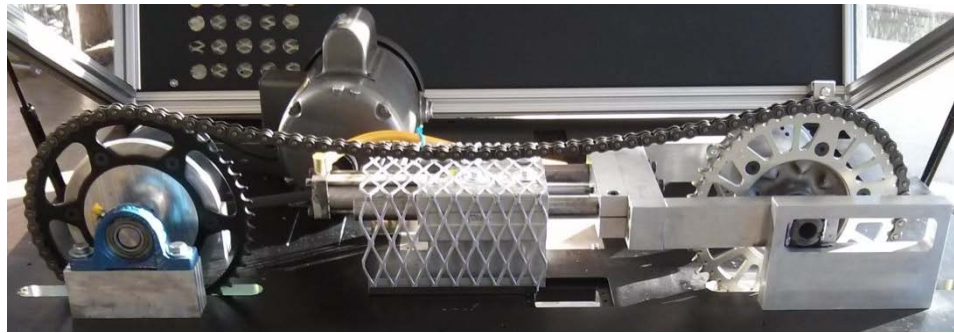

Figure 15 Installed Drivetrain

5.1.4 Pneumatics

With the drivetrain in place, the pneumatic system components were mounted next. The pressure regulator and 3-way air valve were fastened to the control panel, and fittings and hoses were installed with Teflon tape. The yellow air hose was routed through the control panel and through existing cutouts in the tabletop. Figure 15 shows the control panel on the left and the air hose leading to the actuator on the right.

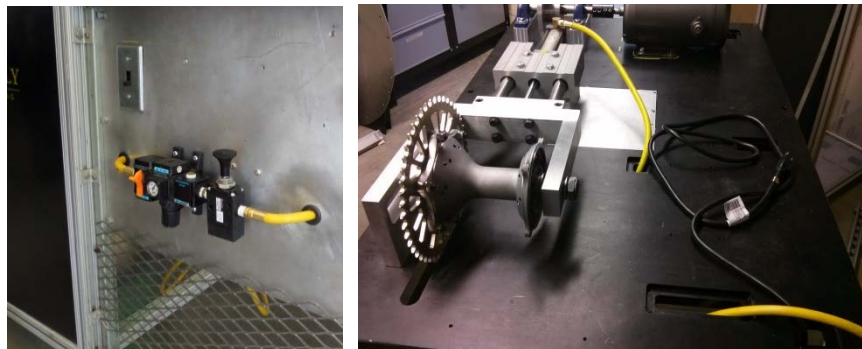

Figure 16 Pressure Regulator/Valve and Hose

5.1.5 Wiring

The last major phase of the machine assembly was the electrical wiring of the motor and switches. This process took several iterations and meetings with Cal Poly Lead Electrician, Ben Johnson, to ensure that that the electrical layout was safe.

The open-end extension cord (power plug) was wired into the first of four electrical conduit boxes, that of the contactor. The power plug line wire connects to the magnetic contactor, while the power plug green wire, grounds to the conduit box and subsequently to the entire machine. The contactor is in parallel with a series of three switches: on/off toggle, emergency stop, and door interlock. Each switch was contained in its own electrical box, with wires out of reach in conduit tubing. The boxes were mounted to the back of the control panel, giving the user easy access to the toggle switch and emergency button. All other electrical components were safely tucked away under the machine.

Safety features were built in with the use of two switches: the emergency switch, normally closed, and the door interlock, normally opened. When the enclosure is fully closed, the door interlock is depressed, the circuit is closed, and the operator cannot power on the machine. Meanwhile, if the emergency stop is pushed, the circuit becomes open, causing the machine to turn off.

When all three switches are activated, in their closed setting, the magnetic switch is energized, and power can be supplied to the motor. The wiring schematic was designed to reflect the actual layout of components as they are located on the machine.

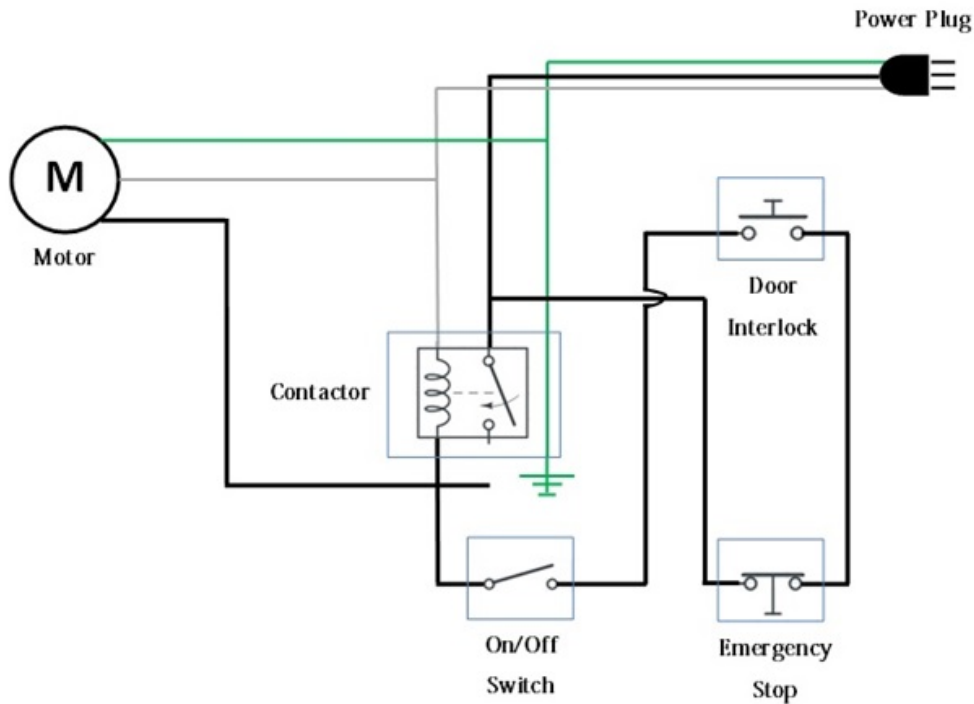

Figure 17 Wiring Schematic

5.1.6 “Bells and Whistles”

Once manufacturing, assembly, and electrical wiring were completed, additional features and finishing touches were added to make the machine clean, safe, and aesthetic. Two black panels were made for the lower half of the table, one on each side, mounted with hinges, and fitted with barrel bolt latches. These panels add an extra barrier between the user and the moving chain, and keep electrical wires and air hoses tucked out of sight. A special black panel was installed in the front with a holographic ‘Cal Poly Engineering’ logo for added sophistication. This front panel cannot be opened and serves to keep anyone from reaching in and accidentally touching the chain.

The control panel of the machine consists of a machined-to-size piece of sheet metal, bolted onto existing guide rails. On this panel lie the pneumatic controls (as described in 5.1.4) and two of the three switches for activation. These controls are clearly labeled on the panel for operator’s safety and to indicate switch/valve direction functionality.

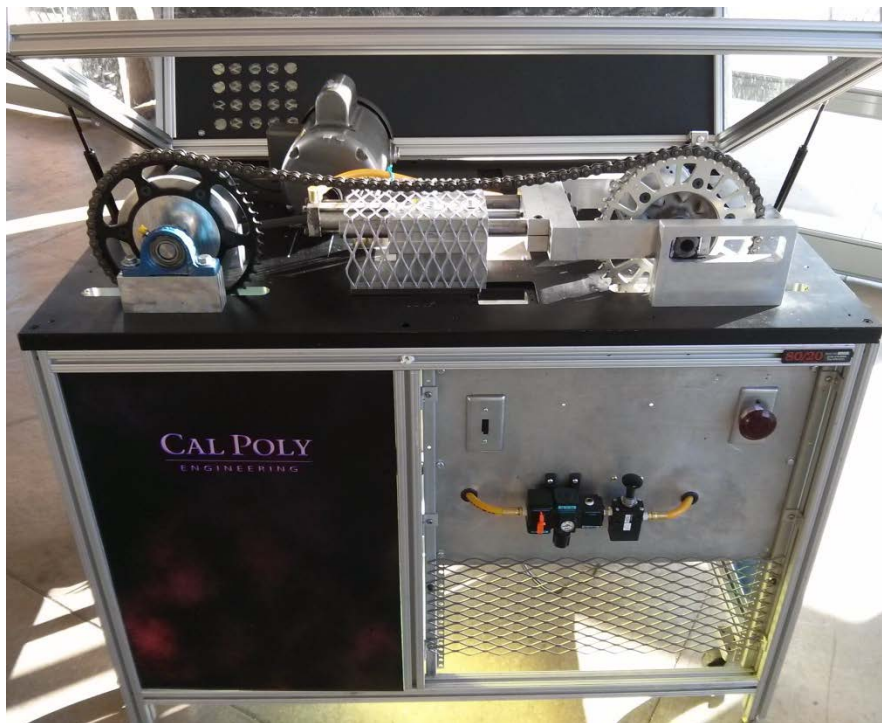

Figure 18 Final Fixture

5.2 Deviations from Final Design

The manufacturing and assembly of the machine remained on schedule, except for one major design change that took place during design verification. During testing it was discovered that the motor was inadequately sized for the system. With the motor capable of spinning at 3450 RPM, the chain drive would spin up, attempt to reach peak RPM, and shut itself off after 15 seconds. The thermal overload protection was being triggered, and this meant the motor would shut off and several minutes were needed for it to cool down before the switch could be reset. After a consultation with the electrician ruled out faulty wiring, a conclusion was made: either a bigger horsepower motor was purchased and installed or a speed reduction was implemented.

The system demanded more torque than the motor could provide, and without a redesign, the chain drive would never be able to run the tests.

Quickly the decision to purchase a bigger motor was ruled out, due to long lead time and high cost, which would put the project over budget. Therefore, the solution would have to occur in the form of speed reduction. However, after extensive searching, it was concluded that insufficient variety in sprocket sizes meant the sprocket speed ratio could not be greatly reduced without requiring a complete redesign of the tabletop platform.

The next option considered was using pulleys and a belt, connected between the motor and drive shaft, to reduce the speed of the system. This option proved to be inexpensive, easy to adapt, and in the end was chosen over any other alternative. Two pulleys, with a ratio of 2.6:1, were sized to fit in the space provided, to reduce the speed by more than 50%, while reducing the rotational load seen by the motor and increasing the amount of torque it applies to the drive shaft.

To install the components of the new reduction system, the motor was shifted over, with new mounting holes drilled into the tabletop, and a keyway for the driveshaft was machined on a manual mill. The pulleys were pressed on to their corresponding shaft, and the belt was set in place and manually tensioned until the motor was bolted down. Since the pulley/belt redesign, the machine has shown superior performance, without any further mechanical problems.

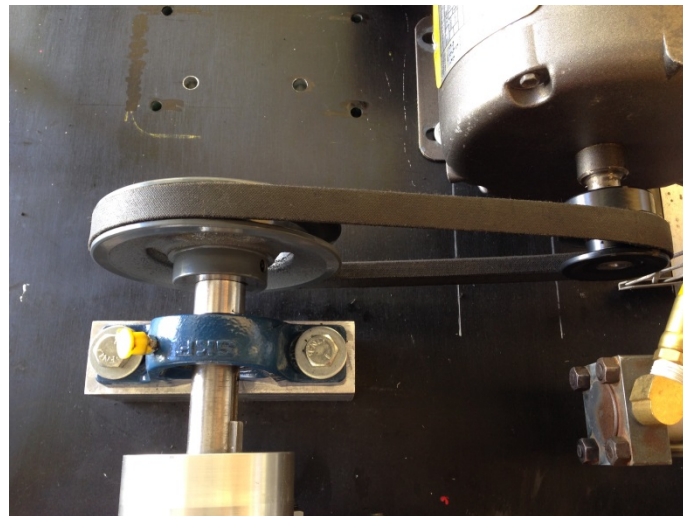

Figure 19 Belt/Pulley Speed Reducer Close-up

5.3 Manufacturing Recommendations

Working on the aluminum tabletop platform has proven to be a consistent manufacturing challenge. Because the machine is so large, there are few mills that can support it. Therefore, the features made into it needed to be precisely located in the CAD model first, so that machining could happen in one or few trips to the mill. A lighter mounting platform is highly recommended for future iterations of the machine, to allow ease of assembly/manufacture, and to reduce overall weight. With the tabletop, much unnecessary weight was added and this only hindered ease of mobility.

6. Design Verification Plan (Testing)

The following sections detail the executed design verification schedule. The order in which the tests are presented illustrate their importance, since the final test was dependent on the success of each previous test. Each test is described and a Design Verification Plan and Report (DVPR) is presented with results.

6.1 Test Descriptions

The following sections describe each test of the design verification testing plan and the equipment required to execute each test. Suggestions, for future reference, are included for each case in the event of a failed test.

6.1.1 Weight and Mobility Test

Specifications # 1 and # 5 were related to the size and mobility of the structure, and required testing upon completion of fixture assembly. The final fixture weight was measured using electronic car scales, with one scale underneath each leg of the table. Also, the final fixture width and length were verified using a measuring tape. The mobility of the structure was assessed by verifying that one person could easily move the testing structure through a doorway.

6.1.2 Chain Test

Specification # 13 stated that variable chain tension would be available during wear testing. A static chain test was anticipated but not implemented. This was due to the limitations in the actuator, which meant that the chain would never operate near its tension capacity.

6.1.3 Actuator Test

The functionality of the pneumatic actuator was tested in order to ensure that the chain tensioning system would work as expected. The system was visually and audibly inspected for leaks, and a calibration test was anticipated but not implemented, due to time constraints.

In the future, a calibration test is recommended. One method can include using a spring with a known spring constant, using the actuator to exert a force on the spring and measuring the deflection. The pressure regulator can be set to a given pressure and the deflection of the spring can be used to determine the actual force output of the actuator. In this way, if there are leaks in the system, they can be fixed before the execution of the wear tests. Also, the calibration constant and any offset of the actuator can be known and can be used to correct results.

6.1.4 Mount Deflection Test

The deflection of the hub swing arm mount was tested in order to ensure that the positioning of the sprocket was constant during the wear tests. The drivetrain was installed and with increasing tension, the deflection of the free side of the mount was measured using a dial indicator. If noticeable deflection occurred then a second slotted mount would be used on the free side to secure it to the tabletop.

6.1.5 Power Test

Specification # 3 stated that the system would operate on wall power. A simple test was executed, after the fixture wiring was complete, to confirm that the motor and the drivetrain operated on 110 V. The test required the installation of all safety switches. If the system was unable to run on 110 V, then the component wiring would be reexamined.

6.1.6 Noise Test

Specification # 7 stated that the system would generate no more than 80 dB of noise. Before the long duration tests were executed, the noise level was confirmed. The test involved turning the system on, letting it reach operating speed and measuring the noise level using a sound meter. If 80 dB were exceeded, then additional noise reducing panels would be installed within the enclosure so as to not cause undue auditory discomfort.

6.1.7 Temperature Test

Specification # 11 stated that the motor would be adequately cooled during operation. A temperature test was done after the system was allowed to reach steady state, and then the temperature changes in the motor housing were monitored. An infrared thermometer was used to take temperature measurements. If the temperature reached 212 °F, the system would be stopped and additional motor cooling would be installed.

6.1.8 Wear Test

The most important results of the project were generated in the final tests: the long duration wear tests of each of the sprockets. Since the system was deemed safe, the long duration tests began, in order to verify that the system could generate measurable wear. Specification # 14 stated the wear tests would generate 3% mass loss of sprocket wear. If the system was unable to generate 3% mass loss, then additional features would be implemented to accelerate the chain and sprocket wear rate or magnify the different wear modes.

6.2 Design Verification Plan and Report (DVPR)

The DVPR, Table 10, is a document that lays out the testing implemented to verify the final design. Each test was associated with a design specification or a component calibration. The DVPR shows test dates, durations, and test results. The details of each test follow in the next sections.

Table 11 Design Verification Plan and Report (DVPR)

TEST PLAN										TEST REPORT			
Item No	Spec No	Test Description	Acceptance Criteria	Tester	Test Stage	SAMPLES TESTED		TIMING		TEST RESULTS			NOTES
						Qty	Type	Start date	Finish date	Test Result	Quantity Pass	Quantity Fail	
1	1	Weight Test: The final fixture is weighed using: scale.	Max Weight	Allian	CV	1	A	4/4/14	4/4/14	340	<350 lb	350 lb	280 lb w/out enclosure; 60 lb enclosure.
2	2	Door-Way Test: Final fixture dimensions measured using: tape measure.	Max Area	Mason	DV	1	B	4/5/14	4/5/14	48 x 31.25"	<48 x 30"	48 x 30"	Pressure regulator protrudes 1.25"
3	13	Chain Test: A static test determines chain at max tension using: actuator.	Max Tension	Mason	PV	1	C	3/31/14	3/31/14	22-45	<129lbs	129lbs	This test was not executed. With actuator limited to 30-80 psi, chain tension is well below yield.
4	NA	Actuator Test: A leak and functionality test to confirm the actuator can maintain constant chain tension.	Min Pressure	Mason	PV	1	C	4/11/14	4/11/14	30-80	>10 psi	10 psi	No leaks detected. Actuator performs best at 30-80 psi.
5	N/A	Mount Deflection Test: The deflection with chain tension for the one sided mount will be measured using: micrometer.	Max Deflection	Allian	PV	1	C	4/12/14	4/12/14	0	<0.010"	0.010"	With chain tension, no deflection was detected.
6	3	Power Test: The system is confirmed to operate on 110 V wall power.	110-120 V	Mason	PV	1	C	5/3/14	5/3/14	On	On	Off	Successfully runs on wall power
7	7	Noise Test: Final system noise level during operation is measured using: sound meter.	Max dB	Mike	CV	1	A	6/6/14	6/6/14	76-78 dB	<80 dB	80 dB	Over a range of conditions, noise test passed.
8	11	Temperature Test: Motor temperature during operation is measured using: infrared thermometer.	Max Temperature	Mike	PV	1	C	6/7/14	6/7/14	144-150	<212F	212F	Motor tested after 3 hours of continuous operation on a warm day. Ventilation is sufficient.
9	14	Wear Test: 3% mass loss sprocket wear using mass balance.	Minimum Wear	Allian	PV	1	C	6/11/14	6/11/14	.005%	>3%	3%	After 20 hours it's clear that the system needs more load to accelerate wear.

6.2.1 Weight and Mobility Test Results

The fixture was weighed using electronic car scales and the total weight is 340 lbs. The enclosure alone weighs 60lbs. The fixture is grossly overweight and exceeded the target of 250 lbs.

The dimensions of the fixture are only slightly over the target, due to the pressure regulator protruding 1 ¼” from the control panel, and the machine fits through a standard doorway. However, due to the sheer weight of the machine, it is not easy to roll by one person. The legs of the machine barely clear the ground and even with the rolling casters, the machine is difficult to maneuver.

6.2.2 Chain Test Results

The chain test was not executed because the regulator was limited to 60 psi. At 60 psi, the chain would not experience more than 45 lbs. of tension, and this fell far below its limit of 129 lbs.

6.2.3 Actuator Test Results

The pneumatic system was connected to the Mustang ‘60 air pressure lines and no leaks were detected in the system. The actuator was tested between 0 and 60 psi, with the optimal range found between 30 and 60psi.

6.2.4 Mount Deflection Test Results

The hub mount was tested for deflection with 60 psi of actuator pressure on the hub. At this maximum pressure, no deflection was observed.

6.2.5 Power Test Results

After much electrical work and component redesign, the system passed its power test and it can successfully run for extended periods of time on wall power without any issues.

6.2.6 Noise Test Results

A sound meter was used to measure the volume of noise made by the machine. With a sound meter pressed right up against the front panel, the highest reading was 77 dB. With the sound meter pressure up against the black panel, directly behind the motor, the highest reading was 78 dB. At different positions around a 10ft radius from the machine, the highest reading was 77.5 dB. The results indicate the machine satisfied its noise level requirement. All readings were taken after the machine had reached steady state.

Table 12 Results of Noise Test

Machine Front (dB)	Back (dB)	Ten ft. Radius (dB)
77	78	77
76	78	77.5
76	78	78

6.2.7 Temperature Test Results

An infrared thermometer was used to take temperature measurements, after the machine had run for three continuous hours. The machine was stopped and the measures quickly taken. In all cases, the motor did not exceed its maximum capacity of 212°F. With the installation of the v-belt, the belt temperature was also monitored. At about 150°F, the belt is hotter than the long life recommendations of operating below 140°F.

Table 13 Results of Temperature Test

Motor Left (°F)	Motor Right (°F)	Belt (°F)
154.1	144.0	150.0
154.5	144.1	150.1
153.9	144.0	149.0

6.2.8 Wear Test Results

After every test was administered and the machine was deemed safe to run for long duration, the aluminum test sprocket was installed and worn. The machine was run for 29 hours of operation at 60 psi actuator pressure, and unfortunately there was hardly any detectable mass loss. There was a 0.02 g difference, for a total of .005% mass loss. If linear wear can be assumed, then achieving 3% on the current system would require over 15000 hours of continuous operation. This is hardly realistic and the system needs to be altered to accelerate the chain and sprocket wear rate or magnify the different wear modes.

Table 14 Results of Al. Wear Test After 29 Hours

Avg. Mass Before (g)	Avg. Mass After (g)	Mass Lost (%)
352.53	352.51	.005

7. Conclusions and Recommendations

The stated objective of developing and building a machine to test the long term wear characteristics in motorcycle sprockets made from different materials was accomplished, and in many respects the machine is excellent in both its design and execution. Initial trouble with the motor's ability to overcome the unexpectedly high dynamic drag in the chain drive when directly connected to the drive shaft was overcome. These "teething" problems were eliminated by the inclusion of a belt driven, speed reduction stage between the motor output shaft and the drive shaft of the chain drive. The pulley and belt configuration of the speed reducer provided a 2.6:1 reduction ratio which was successful at allowing the motor to run the machine continuously without fault. However, upon conducting a preliminary test of an aluminum sprocket, the capacity of the machine to deliver the desired wear results was called into question.

The machine, as a whole, is fully functional and easy to operate. Its construction is rugged and the drivetrain is robust, with long wearing bearings. Complementing the drivetrain is the pneumatic actuator driven, linear motion system that has shown itself to function as intended, keeping a constant tension on the chain throughout the duration of a test regardless of chain elongation. The machine also satisfies the requirement for a platform which allows sprockets to be changed with relative ease for rapid turnaround during consecutive tests.

The initial testing did raise doubts as to the machine's ability to meet one of the principal design requirements. The capability of the machine to generate a rate of sprocket wear that is large enough to condense the duration of tests into a manageable length of time is not certain. Originally, the planned design featured a 1:1 gear ratio and the motor operating at a fixed speed of 3450 RPM, however, due to the necessary addition of the speed reducer, the speed of the test sprocket has been reduced to around 1320 RPM. While this is still a significant speed, which simulates a motorcycle travelling between 90 and 100 miles per hour (dependent on the diameter of the rear tire), it is much slower than the planned speed. From the early design phase it was planned that the machine, operating at a fixed RPM and chain tension, would need to rely predominantly on its speed to generate wear from impact forces between the sprocket teeth and chain rollers. It is now uncertain if this mechanism is powerful enough to generate rapid wear on its own, and additional modifications to the machine may be required to encourage more wear.

Works Cited

Conwell, James C., and G. E. Johnson. "Design, Construction and Instrumentation of a Machine to Measure Tension and Impact Forces in Roller Chain Drives." *Mechanism and Machine Theory* 31.4 (n.d.): 525-31. Print.

"General Purpose Product Data MAKROLON GP." Sheffieldplastics.com. Web. 30 Oct. 2013 <http://www.tapplastics.com/uploads/pdf/Polycarbonate%20GP%20Product%20Data.pdf>

"How to Tell When Worn Sprockets Have to Go." Reynold.com. Web. 22 Oct. 2013 <http://www.renold.com/Company/News/replacing-worn-sprockets.asp>

Lubrication, Friction, and Wear. no. SP-8063. Washington: National Aeronautics and Space Administration, 1971. Print.

Marshek, Kurt M., and Michael O. Ross. Machine for Testing Chain and Sprocket Type Drive Systems. Patent 4413513. 8 Nov. 1983. Print.

Rabinowicz, Ernest. Friction and Wear of Materials. New York: Wiley, 1995.

Ridgely, J. *QFD: Quality Function Deployment* [PowerPoint Slides]. Retrieved from Lecture Notes Online Web site: https://polylearn.calpoly.edu/AY_2013-2014/mod/folder/view.php?id=57359

Thomas, Sabu. *Handbook of Engineering and Specialty Thermoplastics*. Vol. 3. Hoboken: Wiley, 2011. Print.

Voss, H., and K. Friedrich. "On The Wear Behavior of Short-fiber-reinforced PEEK Composites." *Wear* 116 (n.d.): 1-18. Print.

Appendix A: Additional Figures

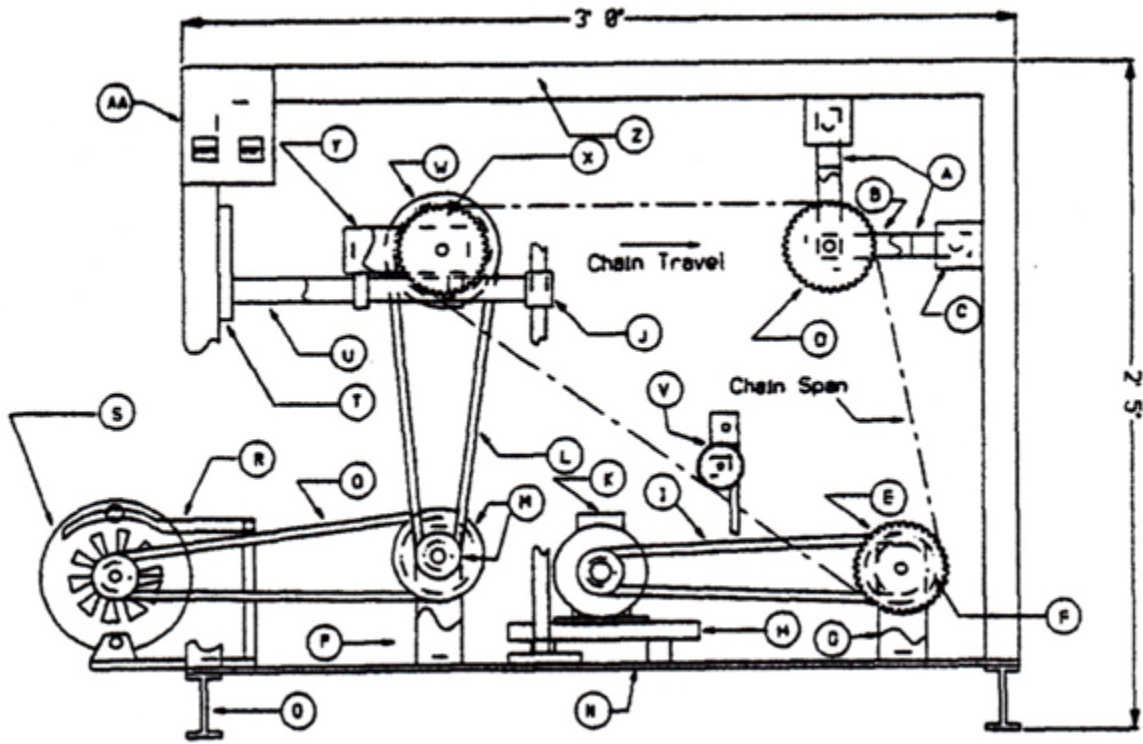

Figure 1 Chain drive testing machine created by James C. Conwell

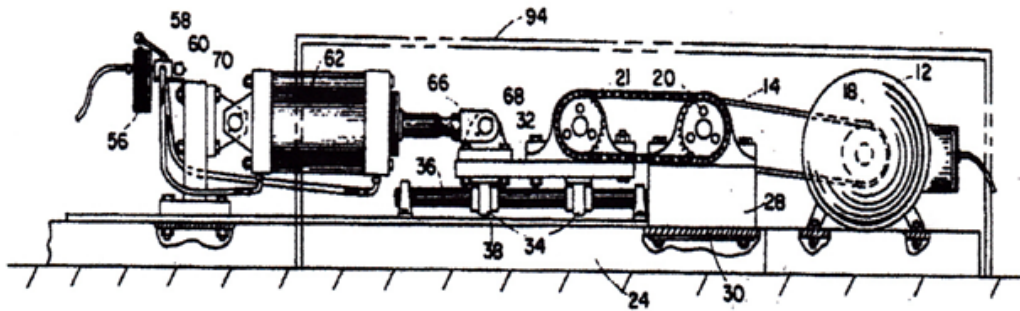

Figure 2 Chain drive test machine designed by Kurt M. Marshek & Micheal O. Ross, U.S. Patent # 4,413,513

Appendix B: Detailed Supporting Analysis

Determining Motor Power

Electric Power Equation

$$\text{Power} = \text{Voltage} * \text{Current}$$

Household circuits are protected by 15 amp circuit breakers.

Therefore, for a 110 volt source:

$$\text{Power} = (110 \text{ Volts}) * (15 \text{ Amps}) = 1650 \text{ Watts}$$

Motors carry efficiencies ranging between 60-70%.

Translating this into horsepower (HP):

$$\text{Horsepower} = \text{Power} * \text{Efficiency} * \frac{[1 \text{ HP}]}{[746 \text{ W}]}$$

For best-case scenario:

$$\text{Horsepower} = (1650 \text{ W}) * (0.70) * \frac{[1 \text{ HP}]}{[746 \text{ W}]} = \mathbf{1.548 \text{ HP}}$$

For worst-case scenario:

$$\text{Horsepower} = (1650 \text{ W}) * (0.60) * \frac{[1 \text{ HP}]}{[746 \text{ W}]} = \mathbf{1.327 \text{ HP}}$$

Time to Wear Aluminum Sprocket

Aluminum sprockets begin to produce measureable wear at 7000 miles.

For a Honda CRF 450 sprocket:

$$\text{Pitch} = \frac{5}{8} \text{ " , \# of Teeth} = 48$$

$$\text{Diameter} = D = 9.9178 \text{ "}$$

Therefore,

$$\frac{\text{Mileage at Wear}}{\text{Sprocket Circumference}} = \text{Total Revolutions}$$
$$7000 \text{ miles} * \frac{5280 \text{ ft}}{1 \text{ mile}} * \frac{12 \text{ in}}{1 \text{ ft}} * \frac{1 \text{ rev}}{(9.9178 * \pi) \text{ in}} = 14,234,689.22 \text{ revolutions}$$

At operating speed of 3450 RPM:

$$\frac{\text{Total Revolutions}}{\text{Operating Speed}} = \text{Test Time}$$

$$14,234,689.22 \text{ rev} * \frac{1 \text{ min}}{3450 \text{ rev}} * \frac{1 \text{ hr}}{60 \text{ min}} = 68.77 \text{ hours}$$

$$68.77 \text{ hours} * \frac{1 \text{ day}}{24 \text{ hours}} = 2.865 \text{ days to produce measurable wear on Aluminum sprocket}$$

Appendix C: QFD House of Quality

<p style="text-align: center;"><i>Quatro Composites Ken Gamble</i></p>		Engineering Requirements													Benchmarks				
		Weighting (Total 100)	Weights < 125 lbs	Measures 3"x6"	5000 Continuous hours	Compliant with campus Health and Safety Regulations	20 lbs or less of force required when rolled by one person	Uses 110 V	Noise < 80 dB	Recessed hardware, polished surface finish	Automatic hourly photo capture	99% reliability	Integrated cooling system	Automatic shut-off upon failure	Uses fasteners to fix sprocket to hub	Adjustable chain tension	Chain sprocket Testing Machine	Roller Chain Impact Tester	
Customer Requirements	Portable	10	○	○			○										1	1	
	Can fit in an office	10	○	○			○										1	1	
	Aesthetic	3							○								1	1	
	Runs on wall power	10			3			○									1	1	
	*Long service life	5			○						○						5	5	
	*Safe	15	1		3	○	○		3		○	○	○				5	5	
	Interchangeable 'test sprocket'	15													○	○	5	5	
	Can offer visual results	3				1				○							1	3	
	Low noise	3			1			○									3	3	
	*Free of overheating	8			○	3					○	○	○				5	1	
	*Simulates long-term wear	20			○						○	○			○		1	1	
	Units																		
	Targets																		
Benchmark #1																○			
Benchmark #2																		○	
● = 9	Strong Correlation																		
○ = 3	Medium Correlation																		
△ = 1	Small Correlation																		
Blank	No Correlation																		

Appendix D: Final Drawings and Parts Lists

Engineering Drawing List		
Drawing #	Description	Quantity
105	Aluminum Table Top	1
200	Enclosure Frame Assembly	1
201	Upright Enclosure Frame Member	4
202	Long Enclosure Frame Member	4
203	Short Enclosure Frame Member	4
300	Machinery Assembly	1
303	9" Stepped Steel Drive Shaft	1
304	Driving Sprocket Mount	1
305	Riser Block for 0.75 Bore Bearing	1
306	Riser Block for 1.0 in Bore Bearing	1
310	Actuator Riser Block	1
311	Hub Mount	1
312	Hub Mount Arm	2
313	Hub Mount Guide Slot	1
400	Complete Assembly	1

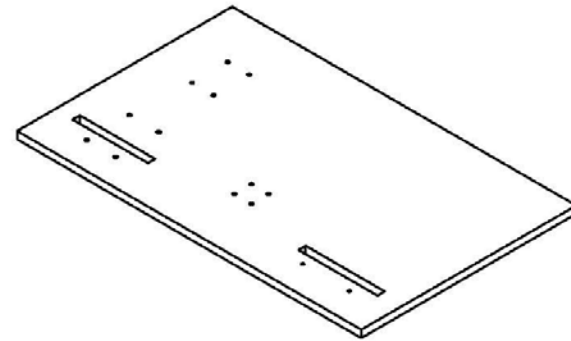
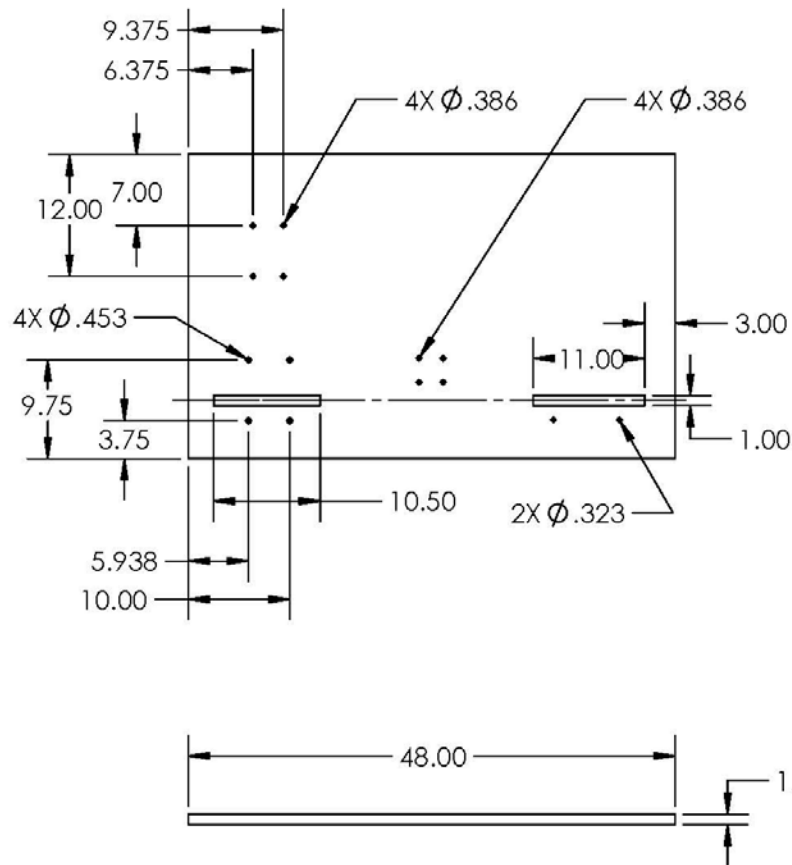

PROPRIETARY AND CONFIDENTIAL
 THE INFORMATION CONTAINED IN THIS DRAWING IS THE SOLE PROPERTY OF QUATRO COMPOSITES. ANY REPRODUCTION IN PART OR AS A WHOLE WITHOUT THE WRITTEN PERMISSION OF QUATRO COMPOSITES IS PROHIBITED.

		UNLESS OTHERWISE SPECIFIED:		NAME	DATE	
		DIMENSIONS ARE IN INCHES	DRAWN			TITLE: TABLETOP PLATE
		TOLERANCES:	CHECKED			
		LINEAR ± 0.005	ENG APPR.			
		ANGULAR $\pm 1^\circ$	MFG APPR.			
		ALL HOLES ARE THROUGH HOLES	Q.A.			SIZE DWG. NO. REV A 105 1
		MATERIAL 6061 AL	COMMENTS:			
		FINISH 63 μ				SCALE: 1:16 WEIGHT: 138 LB SHEET 1 OF 1
NEXT ASSY	USED ON	APPLICATION	DO NOT SCALE DRAWING			

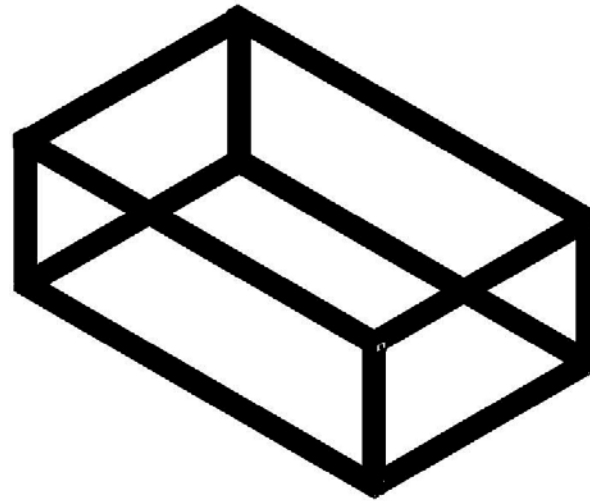

PROPRIETARY AND CONFIDENTIAL
 THE INFORMATION CONTAINED IN THIS DRAWING IS THE SOLE PROPERTY OF QUATRO COMPOSITES. ANY REPRODUCTION IN PART OR AS A WHOLE WITHOUT THE WRITTEN PERMISSION OF QUATRO COMPOSITES IS PROHIBITED.

		UNLESS OTHERWISE SPECIFIED:		NAME	DATE	TITLE: Enclosure Frame Assembly					
		DIMENSIONS ARE IN INCHES TOLERANCES: LINEAR ± 0.005 ANGULAR $\pm 1^\circ$	DRAWN						SIZE A	DWG. NO. 200	REV 1
		INTERPRET GEOMETRIC TOLERANCING PER:	CHECKED								
		MATERIAL:	ENG APPR.								
		FINISH: 63μ	MFG APPR.								
NEXT ASSY	USED ON		Q.A.								
APPLICATION		DO NOT SCALE DRAWING	COMMENTS:								

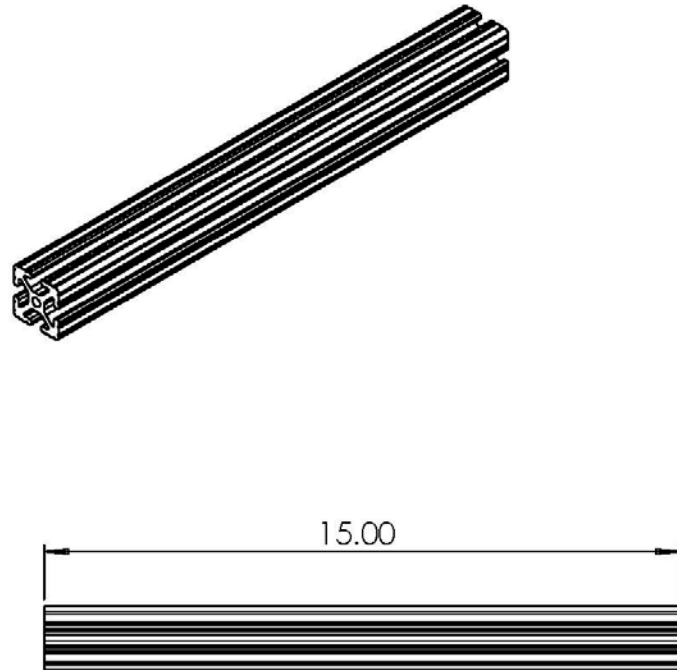
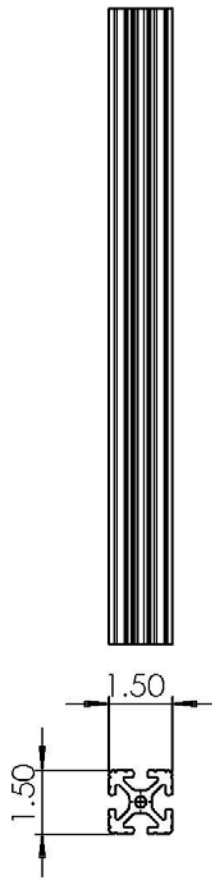

PROPRIETARY AND CONFIDENTIAL
 THE INFORMATION CONTAINED IN THIS DRAWING IS THE SOLE PROPERTY OF QUATRO COMPOSITES. ANY REPRODUCTION IN PART OR AS A WHOLE WITHOUT THE WRITTEN PERMISSION OF QUATRO COMPOSITES IS PROHIBITED.

		UNLESS OTHERWISE SPECIFIED:		NAME	DATE				
		DIMENSIONS ARE IN INCHES TOLERANCES: LINEAR: ± 0.03125 ANGULAR: $\pm 1^\circ$	DRAWN			TITLE: Enclosure Upright Member			
		INTERPRET GEOMETRIC TOLERANCING PER:	CHECKED						
		MATERIAL 6061 AL	ENG APPR.						
		FINISH: 63 μ	MFG APPR.						
NEXT ASSY	USED ON		Q.A.			SIZE A	DWG. NO. 201	REV 1	
APPLICATION		DO NOT SCALE DRAWING	COMMENTS:				SCALE: 1:4	WEIGHT: 2LB	SHEET 1 OF 1

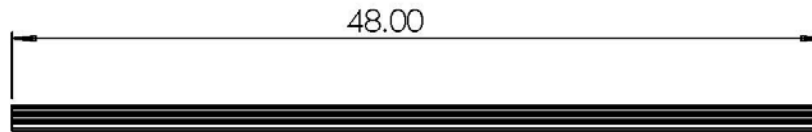
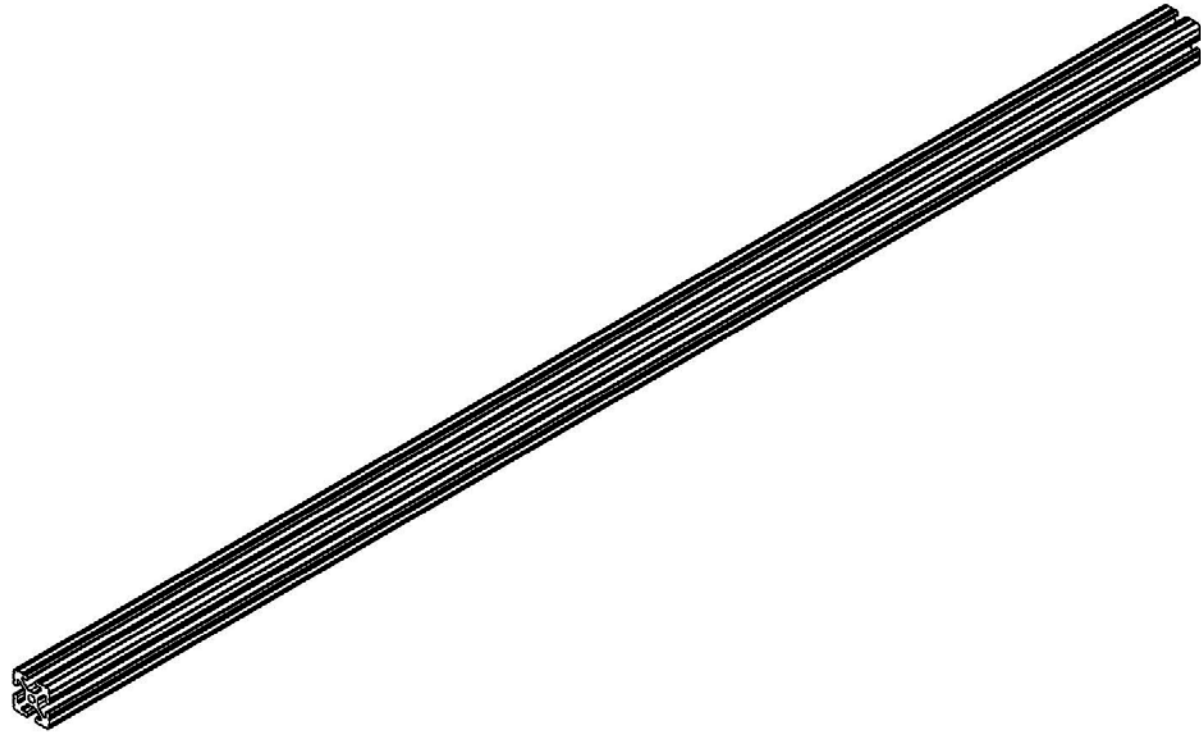
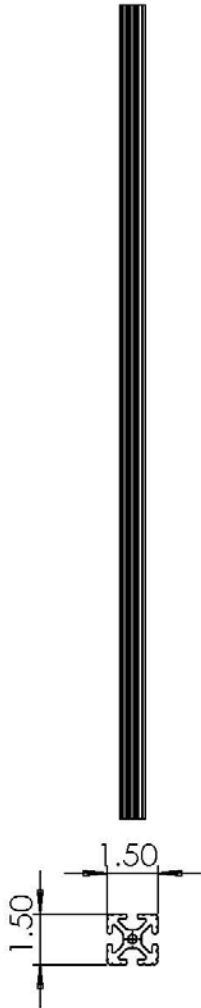

PROPRIETARY AND CONFIDENTIAL
 THE INFORMATION CONTAINED IN THIS DRAWING IS THE SOLE PROPERTY OF QUATRO COMPOSITES. ANY REPRODUCTION IN PART OR AS A WHOLE WITHOUT THE WRITTEN PERMISSION OF QUATRO COMPOSITES IS PROHIBITED.

		UNLESS OTHERWISE SPECIFIED:		NAME	DATE			
		DIMENSIONS ARE IN INCHES	DRAWN			TITLE: Long Enclosure Member		
		TOLERANCES:	CHECKED					
		LINEAR: ± 0.005	ENG APPR.					
		ANGULAR: $\pm 1^\circ$	MFG APPR.					
		INTERPRET GEOMETRIC TOLERANCING PER:	Q.A.			SIZE	DWG. NO.	
		MATERIAL	COMMENTS:			A	202	REV
		6061 AL						
		FINISH				SCALE: 1:10	WEIGHT: 5LB	SHEET 1 OF 1
		63 μ						
		APPLICATION						
		DO NOT SCALE DRAWING						
NEXT ASSY	USED ON							

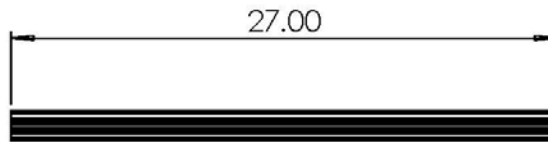
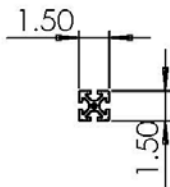
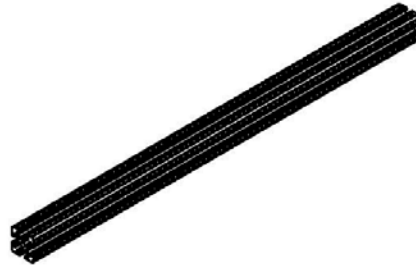

PROPRIETARY AND CONFIDENTIAL
 THE INFORMATION CONTAINED IN THIS DRAWING IS THE SOLE PROPERTY OF QUATRO COMPOSITES. ANY REPRODUCTION IN PART OR AS A WHOLE WITHOUT THE WRITTEN PERMISSION OF QUATRO COMPOSITES IS PROHIBITED.

		UNLESS OTHERWISE SPECIFIED:		NAME	DATE	
		DIMENSIONS ARE IN INCHES	DRAWN			TITLE: Short Enclosure Member
		TOLERANCES:	CHECKED			
		LINEAR: ± 0.005	ENG APPR.			
		ANGULAR: $\pm 1^\circ$	MFG APPR.			
		INTERPRET GEOMETRIC TOLERANCING PER:	Q.A.			
		MATERIAL	COMMENTS:			SIZE
		6061 AL				DWG. NO.
		FINISH				203
	NEXT ASSY	USED ON				REV
						1
	APPLICATION	DO NOT SCALE DRAWING				SCALE: 8
						WEIGHT: 3LB
						SHEET 1 OF 1

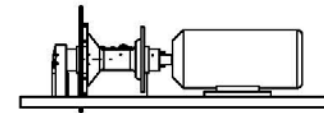
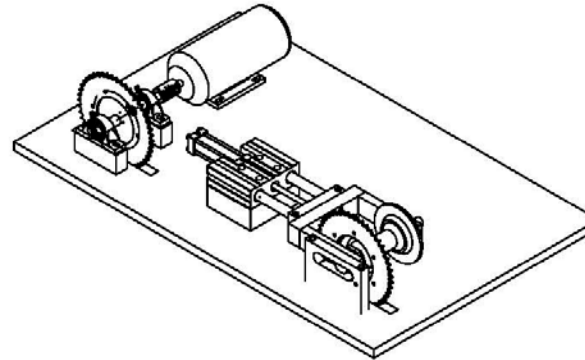
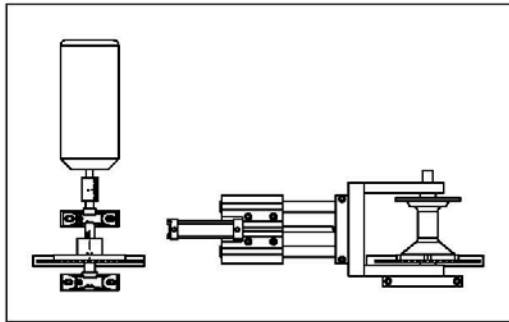

PROPRIETARY AND CONFIDENTIAL
 THE INFORMATION CONTAINED IN THIS DRAWING IS THE SOLE PROPERTY OF QUATRO COMPOSITES. ANY REPRODUCTION IN PART OR AS A WHOLE WITHOUT THE WRITTEN PERMISSION OF QUATRO COMPOSITES IS PROHIBITED.

		UNLESS OTHERWISE SPECIFIED:		NAME	DATE	TITLE: MACHINERY ASSEMBLY					
		DIMENSIONS ARE IN INCHES TOLERANCES: LINEAR: ± 0.005 ANGULAR: $\pm 1^\circ$	DRAWN						SIZE A	DWG. NO. 300	REV 1
		INTERPRET GEOMETRIC TOLERANCING PER:	CHECKED								
		MATERIAL:	ENG APPR.								
		FINISH: 63μ	MFG APPR.								
NEXT ASSY	USED ON		Q.A.			SCALE: 1:16 WEIGHT: SHEET 1 OF 1					
APPLICATION		DO NOT SCALE DRAWING	COMMENTS:								

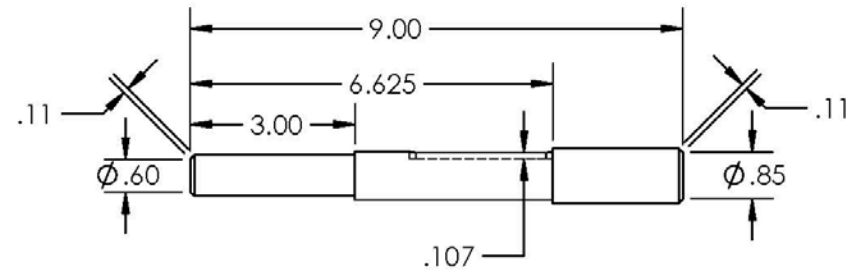
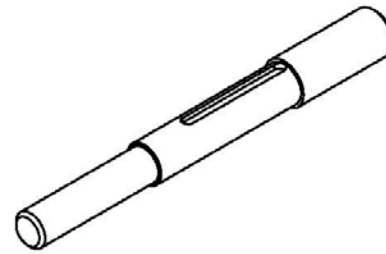
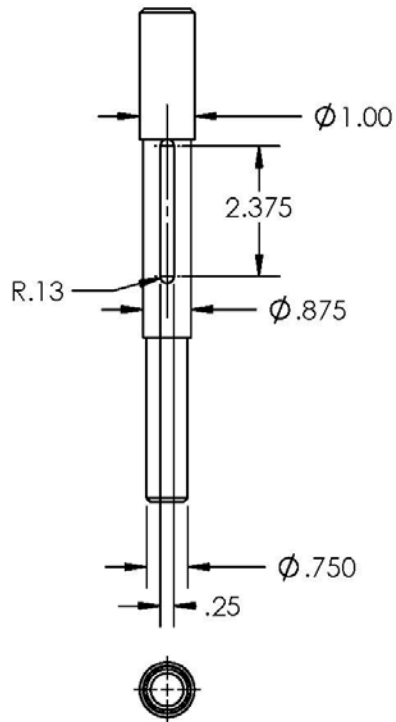

PROPRIETARY AND CONFIDENTIAL
 THE INFORMATION CONTAINED IN THIS DRAWING IS THE SOLE PROPERTY OF QUATRO COMPOSITES. ANY REPRODUCTION IN PART OR AS A WHOLE WITHOUT THE WRITTEN PERMISSION OF QUATRO COMPOSITES IS PROHIBITED.

		UNLESS OTHERWISE SPECIFIED:		NAME	DATE	TITLE: Drive Shaft	
		DIMENSIONS ARE IN INCHES TOLERANCES: UNLESS SPECIFIED LINEAR ± 0.005 ANGULAR $\pm 1^\circ$		DRAWN			
		INTERPRET GEOMETRIC TOLERANCING PER:		CHECKED		SIZE A DWG. NO. 303 REV 1	
		MATERIAL Steel		ENG APPR.			
NEXT ASSY		USED ON		MFG APPR.		SCALE: 1:4 WEIGHT: 0.19 LB SHEET 1 OF 1	
APPLICATION		DO NOT SCALE DRAWING		Q.A.			
				COMMENTS:			
		FINISH 63μ					

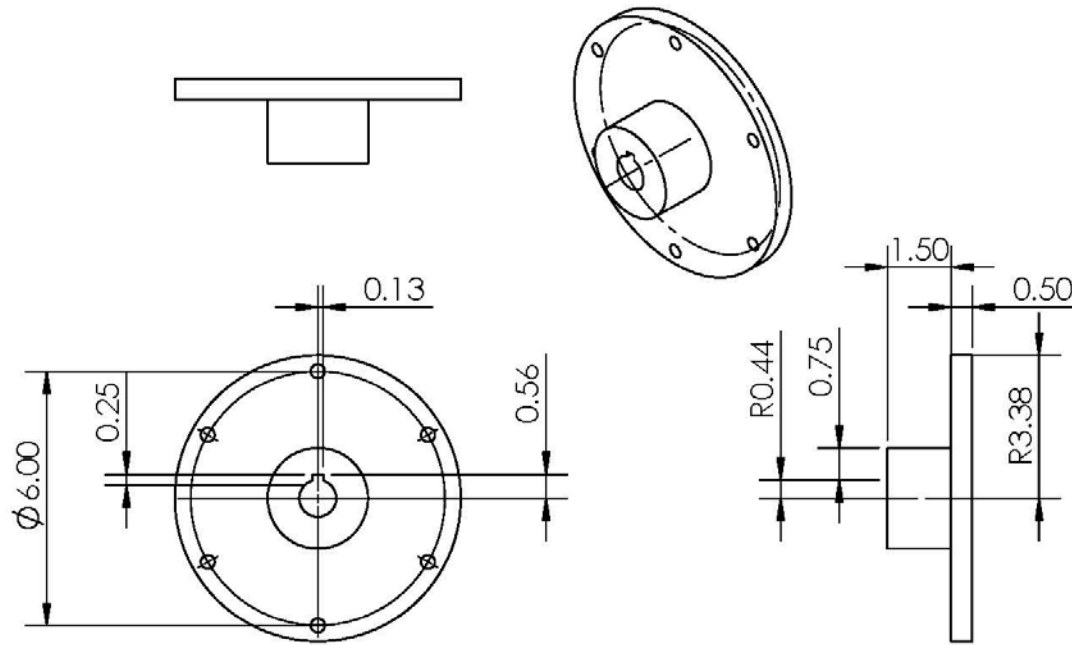

PROPRIETARY AND CONFIDENTIAL
 THE INFORMATION CONTAINED IN THIS DRAWING IS THE SOLE PROPERTY OF QUATRO COMPOSITES. ANY REPRODUCTION IN PART OR AS A WHOLE WITHOUT THE WRITTEN PERMISSION OF QUATRO COMPOSITES IS PROHIBITED.

		UNLESS OTHERWISE SPECIFIED:		NAME	DATE	
		DIMENSIONS ARE IN INCHES TOLERANCES: LINEAR: ± 0.005 ANGULAR: MACH $\pm 1^\circ$	DRAWN			TITLE: DRIVING SPROCKET MOUNT
		INTERPRET GEOMETRIC TOLERANCING PER:	CHECKED			
		MATERIAL 6061 AL	ENG APPR.			
		FINISH 63 μ	MFG APPR.			
			Q.A.			
NEXT ASSY	USED ON		COMMENTS:			SIZE A DWG. NO. 304 REV 1
APPLICATION		DO NOT SCALE DRAWING				SCALE: 1:4 WEIGHT: 2LB SHEET 1 OF 1

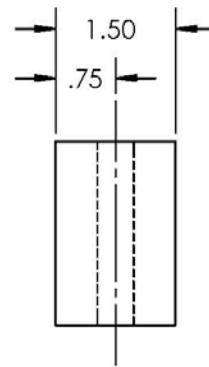
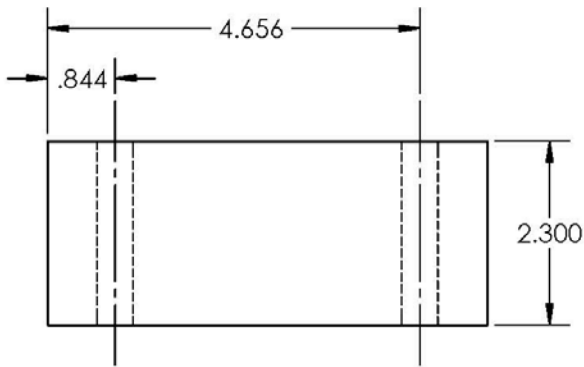
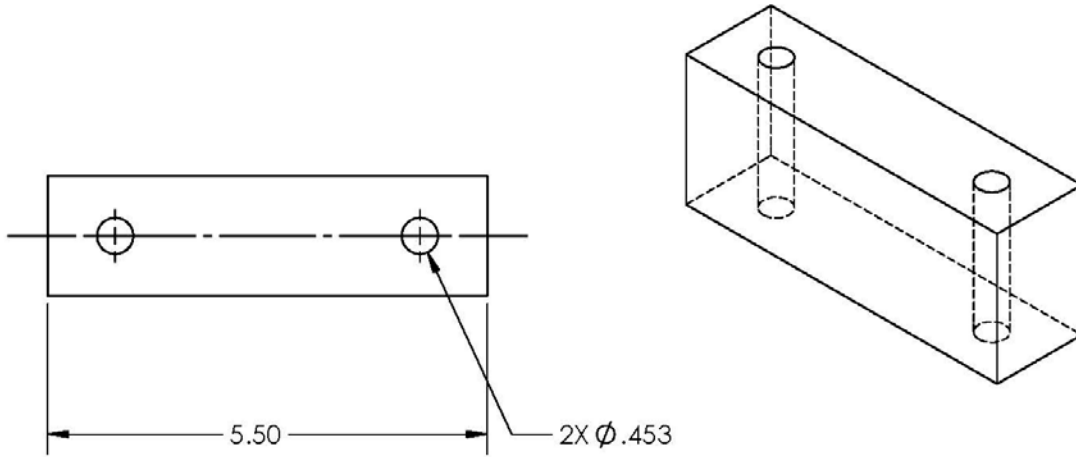

PROPRIETARY AND CONFIDENTIAL
 THE INFORMATION CONTAINED IN THIS DRAWING IS THE SOLE PROPERTY OF QUATRO COMPOSITES. ANY REPRODUCTION IN PART OR AS A WHOLE WITHOUT THE WRITTEN PERMISSION OF QUATRO COMPOSITES IS PROHIBITED.

		DIMENSIONS ARE IN INCHES TOLERANCES:		NAME	DATE
		UNLESS SPECIFIED: LINEAR ± 0.005 ANGULAR $\pm 1^\circ$		DRAWN	
		MATERIAL 6061 AL		CHECKED	
		FINISH 63 μ		ENG APPR.	
NEXT ASSY	USED ON			MFG APPR.	
APPLICATION		DO NOT SCALE DRAWING		Q.A.	
				COMMENTS:	
				0.75 IN BORE BEARING RISER BLOCK	
		SIZE A	DWG. NO. 305	REV. 1	
		SCALE: 1:2	WEIGHT: 0.66 LB	SHEET 1 OF 1	

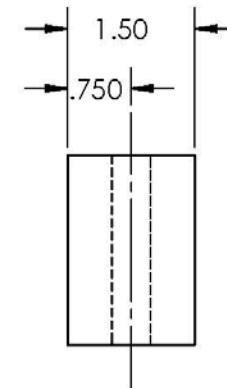
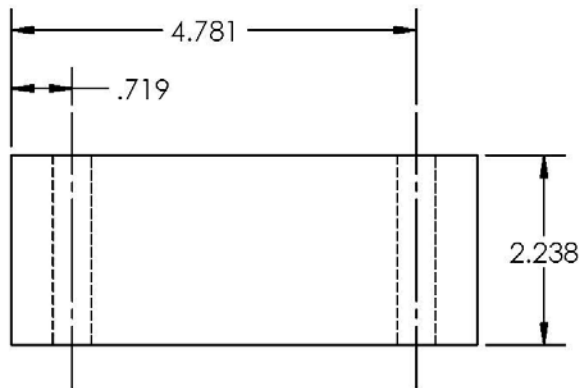
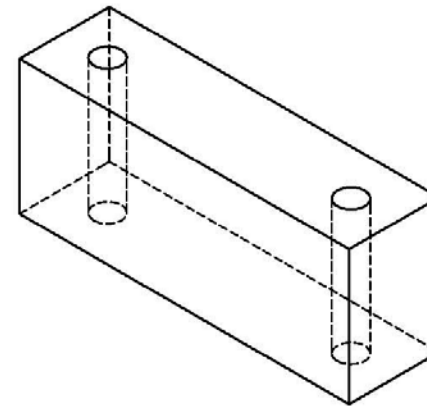
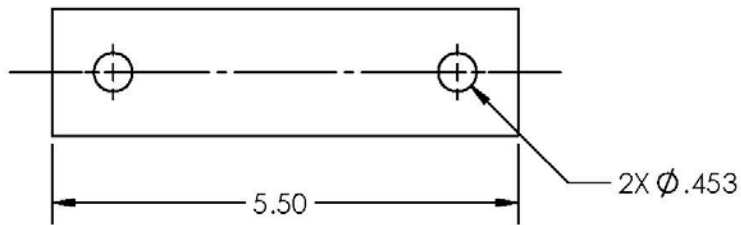

PROPRIETARY AND CONFIDENTIAL
 THE INFORMATION CONTAINED IN THIS DRAWING IS THE SOLE PROPERTY OF QUATRO COMPOSITES. ANY REPRODUCTION IN PART OR AS A WHOLE WITHOUT THE WRITTEN PERMISSION OF QUATRO COMPOSITES IS PROHIBITED.

		UNLESS OTHERWISE SPECIFIED:		NAME	DATE			
		DIMENSIONS ARE IN INCHES TOLERANCES:		DRAWN		TITLE: 1.0 IN BORE BEARING RISER BLOCK		
		LINEAR ± 0.005 ANGULAR $\pm 1^\circ$		CHECKED				
		INTERPRET GEOMETRIC TOLERANCING PER:		ENG APPR.				
		MATERIAL		MFG APPR.				
		6061 AL		Q.A.				
NEXT ASSY		USED ON		COMMENTS:		SIZE	DWG. NO.	REV
						A	306	1
APPLICATION		DO NOT SCALE DRAWING				SCALE: 1:2	WEIGHT: 0.64 LB	SHEET 1 OF 1

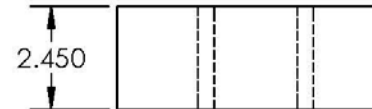
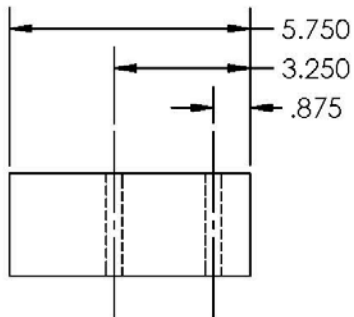
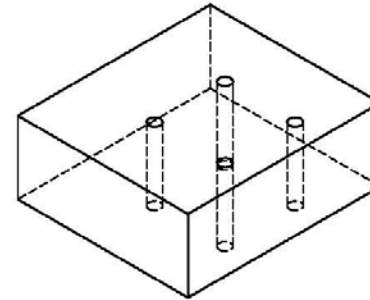
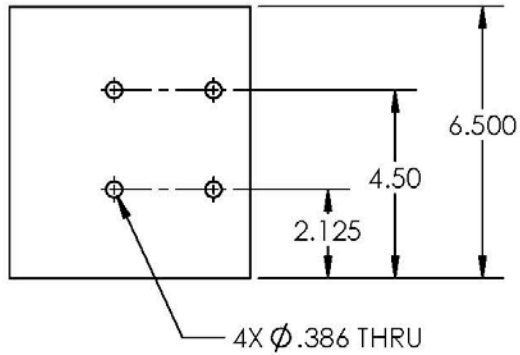

PROPRIETARY AND CONFIDENTIAL
 THE INFORMATION CONTAINED IN THIS DRAWING IS THE SOLE PROPERTY OF QUATRO COMPOSITES. ANY REPRODUCTION IN PART OR AS A WHOLE WITHOUT THE WRITTEN PERMISSION OF QUATRO COMPOSITES IS PROHIBITED.

		UNLESS OTHERWISE SPECIFIED:		NAME	DATE	
		DIMENSIONS ARE IN INCHES	DRAWN			TITLE: ACTUATOR RISER BLOCK
		TOLERANCES:	CHECKED			
		LINEAR ± 0.005	ENG APPR.			
		ANGULAR $\pm 1^\circ$	MFG APPR.			
		ALL HOLES ARE THROUGH	Q.A.			
		MATERIAL 6061 AL	COMMENTS:			SIZE A
NEXT ASSY	USED ON	FINISH 63μ				DWG. NO. 310
APPLICATION		DO NOT SCALE DRAWING				REV
						SCALE: 1:4 WEIGHT: 3.27 LB SHEET 1 OF 1

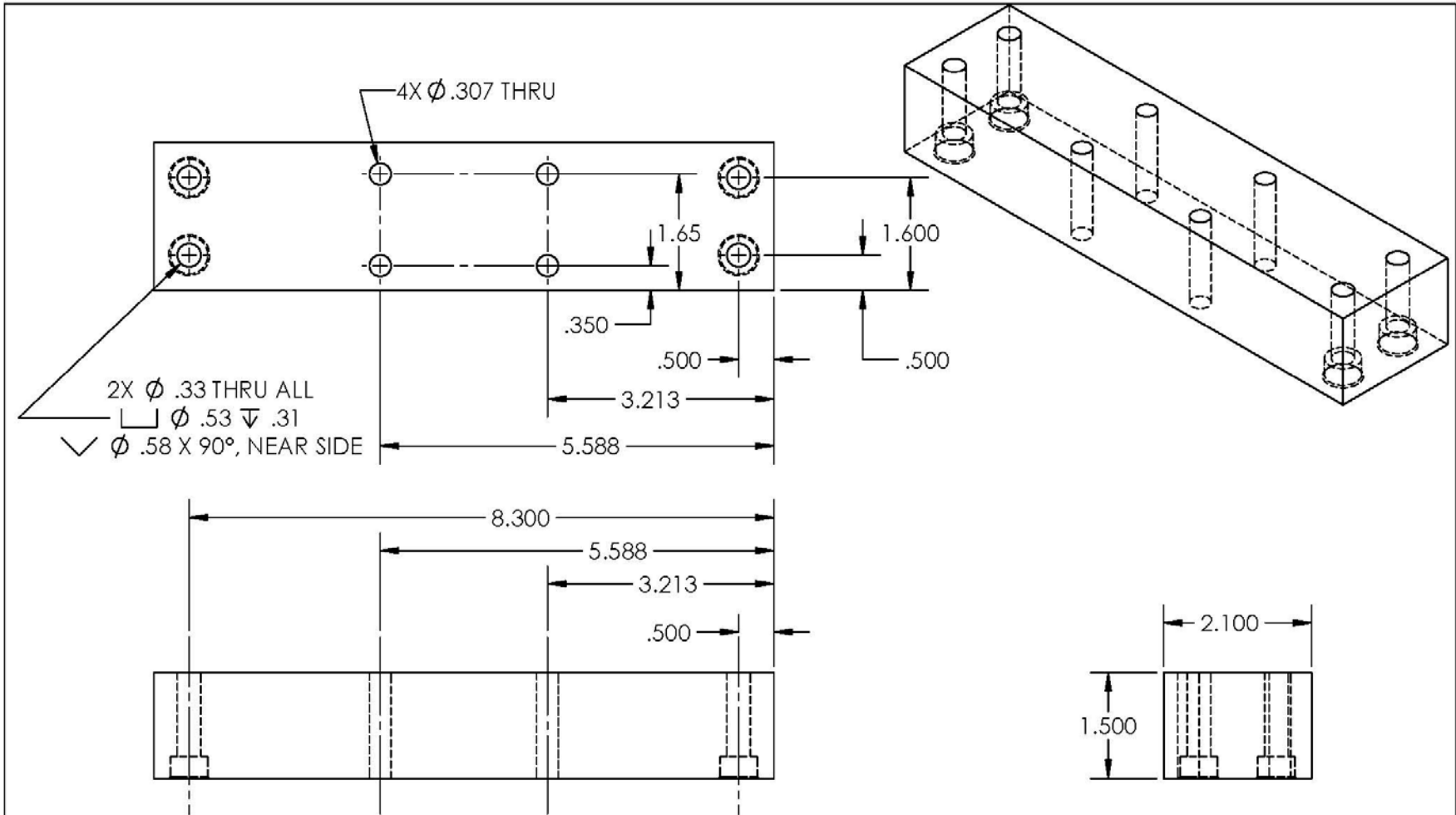

PROPRIETARY AND CONFIDENTIAL
 THE INFORMATION CONTAINED IN THIS DRAWING IS THE SOLE PROPERTY OF QUATRO COMPOSITES. ANY REPRODUCTION IN PART OR AS A WHOLE WITHOUT THE WRITTEN PERMISSION OF QUATRO COMPOSITES IS PROHIBITED.

		UNLESS OTHERWISE SPECIFIED:		NAME	DATE	TITLE: Hub Mount					
		DIMENSIONS ARE IN INCHES TOLERANCES:	DRAWN						SIZE A	DWG. NO. 311	REV 1
		LINEAR \pm 0.005 ANGULAR \pm 1°	CHECKED								
		INTERPRET GEOMETRIC TOLERANCING PER:	ENG APPR.								
		MATERIAL 6061 AL	MFG APPR.								
NEXT ASSY	USED ON	FINISH 63μ	Q.A.								
APPLICATION		DO NOT SCALE DRAWING	COMMENTS:								

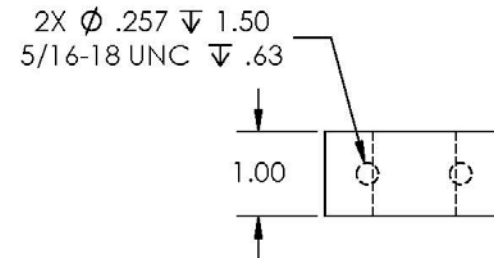
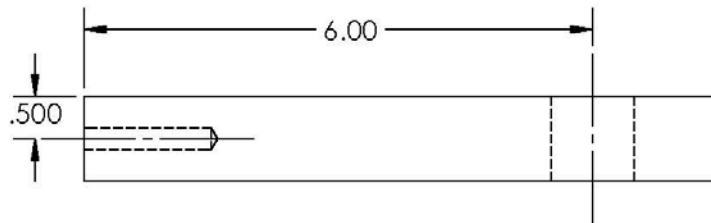
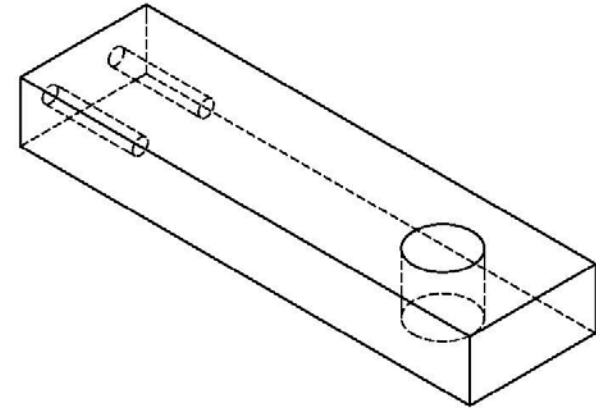

PROPRIETARY AND CONFIDENTIAL
 THE INFORMATION CONTAINED IN THIS DRAWING IS THE SOLE PROPERTY OF QUATRO COMPOSITES. ANY REPRODUCTION IN PART OR AS A WHOLE WITHOUT THE WRITTEN PERMISSION OF QUATRO COMPOSITES IS PROHIBITED.

		UNLESS OTHERWISE SPECIFIED:		NAME	DATE		
		DIMENSIONS ARE IN INCHES TOLERANCES:		DRAWN		TITLE:	
		LINEAR ± 0.005 ANGULAR $\pm 1^\circ$		CHECKED		Hub Mount Arm	
		INTERPRET GEOMETRIC TOLERANCING PER:		ENG APPR.		SIZE DWG. NO. REV	
		MATERIAL		MFG APPR.		A 312 1	
NEXT ASSY	USED ON	6061 AL		Q.A.		SCALE: 1:2 WEIGHT: 1.45 LB SHEET 1 OF 1	
APPLICATION		FINISH		COMMENTS:			
		63 μ					
		DO NOT SCALE DRAWING					

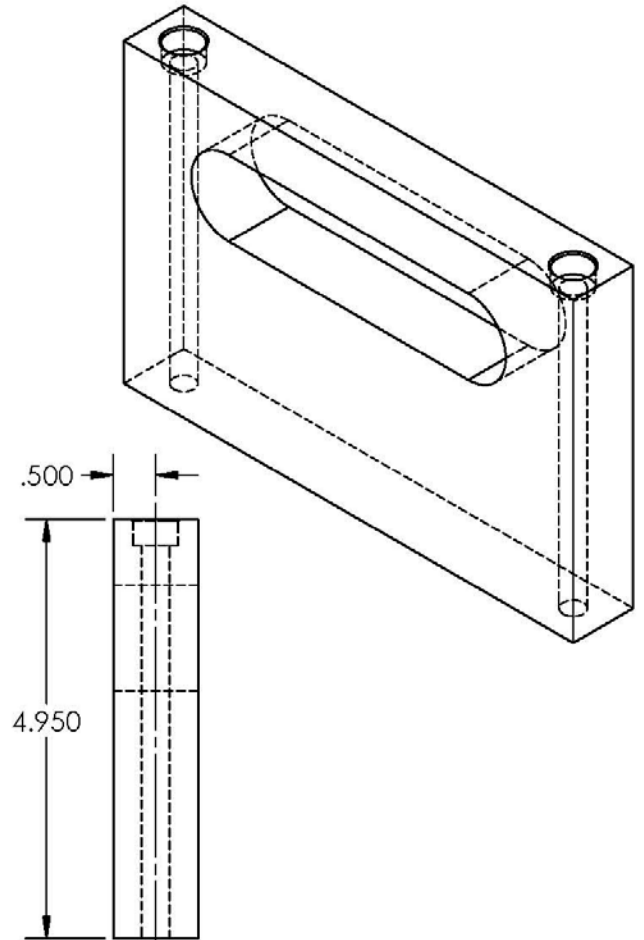
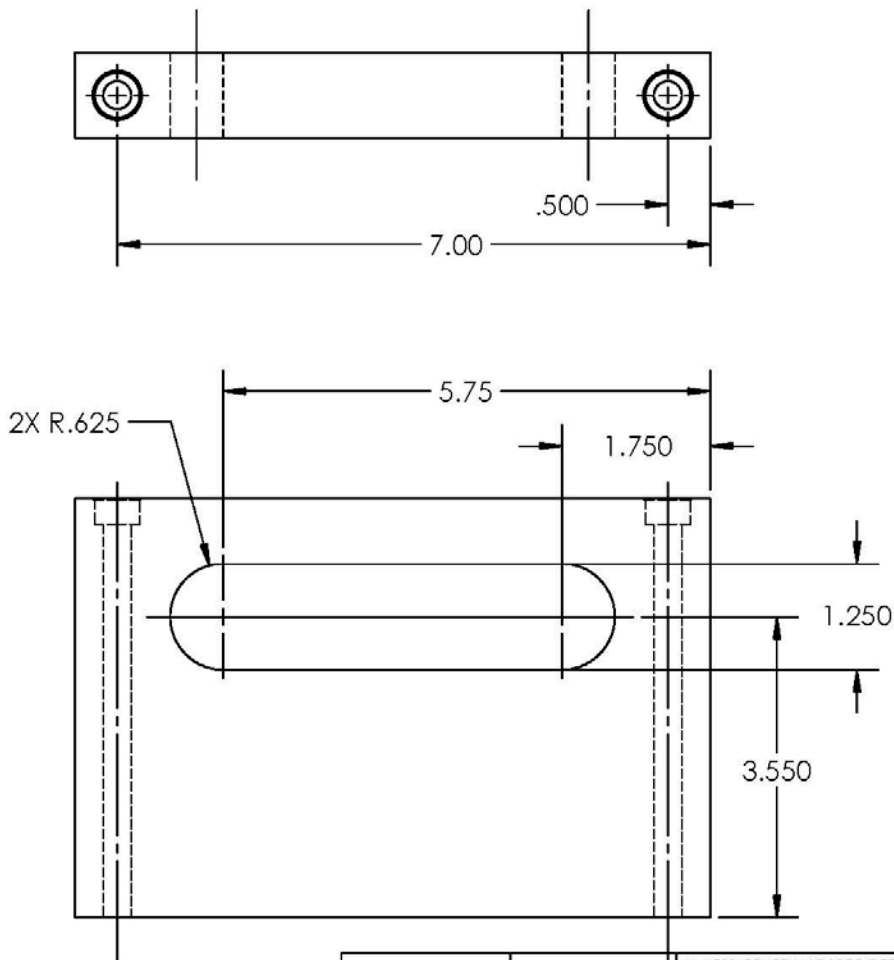

PROPRIETARY AND CONFIDENTIAL
 THE INFORMATION CONTAINED IN THIS DRAWING IS THE SOLE PROPERTY OF QUATRO COMPOSITES. ANY REPRODUCTION IN PART OR AS A WHOLE WITHOUT THE WRITTEN PERMISSION OF QUATRO COMPOSITES IS PROHIBITED.

		UNLESS OTHERWISE SPECIFIED:	NAME	DATE		
		DIMENSIONS ARE IN INCHES	DRAWN		TITLE:	
		TOLERANCES:	CHECKED		Hub Mount Guide Slot	
		LINEAR ± 0.005	ENG APPR.		SIZE	DWG. NO.
		ANGULAR $\pm 1^\circ$	MFG APPR.		A	313
		INTERPRET GEOMETRIC TOLERANCING PER:	Q.A.		REV	1
		MATERIAL	COMMENTS:		SCALE: 1:2 WEIGHT: 2.92 LB SHEET 1 OF 1	
NEXT ASSY	USED ON	6061 AL				
		FINISH				
		63 μ				
APPLICATION		DO NOT SCALE DRAWING				

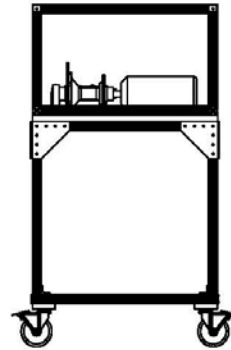
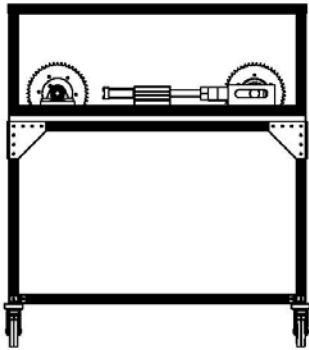
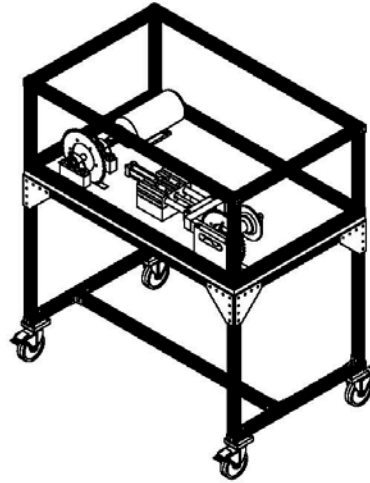
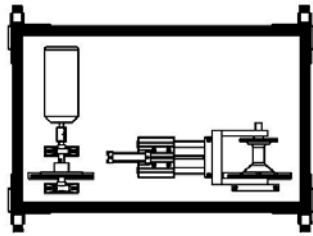

<p>PROPRIETARY AND CONFIDENTIAL THE INFORMATION CONTAINED IN THIS DRAWING IS THE SOLE PROPERTY OF QUATRO COMPOSITES. ANY REPRODUCTION IN PART OR AS A WHOLE WITHOUT THE WRITTEN PERMISSION OF QUATRO COMPOSITES IS PROHIBITED.</p>			DIMENSIONS ARE IN INCHES TOLERANCES: UNLESS SPECIFIED LINEAR: ± 0.005 ANGULAR: $\pm 1^\circ$	NAME	DATE	COMPLETE ASSEMBLY	
				DRAWN			
				CHECKED			
				ENG APPR.			
				MFG APPR.			
		MATERIAL:		Q.A.			
		FINISH: 63μ		COMMENTS:			
	NEXT ASSY	USED ON				SIZE	
	APPLICATION	DO NOT SCALE DRAWING				DWG. NO.	
						400	
						SCALE: 1/24	
						WEIGHT: 277 LB	
						REV. 1	
						SHEET 1 OF 1	

Appendix E: Detailed Cost Analysis

Description	Subsystem	Supplier	Catalog/Part #	Quantity	Unit Cost (\$)	Total Cost (\$)
Aluminum 1.5" x 1.5" 1515 T-Slot Extrusions	Structure	McMaster-Carr	47065T102	8	39.31	314.48
80/20 1010 Extrusion End Caps	Structure	McMaster-Carr	47065T87	6	1.5	9.00
Corner Joining Bracket or 90 Degree Brace	Structure	McMaster-Carr	5537T51	16	7.98	127.68
5" Flange Mount Swivel Caster w/ Brake	Structure	Grainger Industrial	5JRN0	4	57.6	230.40
15 Series Flange Mount Caster Base Plate	Structure	Grainger Industrial	5JRN1	4	28.7	114.80
Aluminum Table Top	Structure	n/a	n/a	1	500	500.00
4' x 4' x 0.125" Polycarbonate Panel	Safety Shielding	McMaster-Carr	8574K83	1	76.09	76.09
2' x 3' x 0.125" Polycarbonate Panel	Safety Shielding	McMaster-Carr	8574K265	2	37.28	74.56
80/20 15 Series Aluminum Hinge	Structure	Grainger Industrial	5JRL8	2	11.39	22.78
Deadbolt w/ Side Latch	Structure	Grainger Industrial	16U358	2	32.15	64.30
80/20 15 Series 1" Wide Handle	Structure	Grainger Industrial	16U357	1	11.66	11.66
Grizzly G2535 1.5 HP Electric Motor	Electromechanical	Grizzly Industrial, Inc.	G2535	1	207.95	207.95
5/8" to 3/4" Shaft Coupler	Drivetrain	McMaster-Carr	61005K544	1	53.81	53.81
9" Stepped Steel Drive Shaft	Drivetrain	McMaster-Carr	8641T5	1	24.45	24.45

6061 Aluminum Stock for Driving Sprocket Mount	Drivetrain	McMaster-Carr	TBD	1	TBD	TBD
6061 Aluminum Stock for Bearing Mount Block	Drivetrain	McMaster-Carr	8975K167	1	27.57	27.57
Cast Iron Base-Mounted Steel Ball Bearing, 1" Bore	Drivetrain	McMaster-Carr	6361K37	1	39.68	39.68
Cast Iron Base-Mounted Steel Ball Bearing, 3/4" Bore	Drivetrain	McMaster-Carr	6361K34	1	43.16	43.16
Steel Machine Key, 0.25" Square Size	Drivetrain	McMaster-Carr	98870A440	1	10.93	10.93
6061 Aluminum Stock For Actuator Riser Block	Linear Motion	McMaster-Carr	8975K317	1	67.32	67.32
6061 Aluminum Stock for Hub Mount	Drivetrain	McMaster-Carr	8975K311	1	22.16	22.16
6061 Aluminum Stock for Hub Mount Arm	Drivetrain	McMaster-Carr	8975K411	2	17.52	35.04
6061 Aluminum Stock for Hub Mount Guide Slot	Drivetrain	McMaster-Carr	8975K335	1	44.36	44.36
3-Way Air Directional Control Valve	Linear Motion	McMaster-Carr	2700K14	1	81.88	81.88
Pneumatic Linear Actuator	Linear Motion	PHD Inc.	SED25X4X1-E	1	500	500.00
Air Pressure Regulator	Linear Motion	Wilkerson	R26	1	90	90.00
CR450 Rear Motorcycle Hub/Wheel	Drivetrain	Honda Parts Nation	42635-KRN-710	1	176.92	176.92
CR450 Rear Motorcycle Axle	Drivetrain	Honda Parts Nation	42301-KZ4-J40	1	30.05	30.05
CR450 Rear Motorcycle Axle Nut	Drivetrain	Honda Parts Nation	90305-KZ4-J20	1	5.69	5.69
CR450 Rear Motorcycle Axle Washer	Drivetrain	Honda Parts Nation	90401-KZ4-J20	1	1.73	1.73
CR450 Rear Motorcycle Axle Collar Left	Drivetrain	Honda Parts Nation	42305-KZ4-J40	1	9.74	9.74

CR450 Rear Motorcycle Axle Collar Right	Drivetrain	Honda Parts Nation	42306-KZ4-J20	1	11.79	11.79
CR450 Rear Motorcycle Wheel Side Collar	Drivetrain	Honda Parts Nation	42311-KZ4-J40	2	12.22	24.44
520 Motorcycle Chain (25 ft)	Drivetrain	Motorcycle Superstore	35078	1	101.95	101.95
Steel CR450 Sprocket	Drivetrain	Vortex Racing	TBD	1	60	60.00
Aluminum CR450 Sprocket	Drivetrain	Vortex Racing	TBD	1	85	85.00
Hardware and miscellaneous						330.14
					Sum	3,631.51

Appendix F:

**QUATRO COMPOSITES TECHNICAL MANUAL
MASTER ABRADER
WEAR TESTING MACHINE**

**EMPLOYMENT
OPERATION
AND
MAINTENANCE**



**California Polytechnic University
Senior Project Academic Year 2013 - 2014**

CONTENTS

I. OVERVIEW

- A. Description
- B. Purpose
- C. Employment

II. MACHINE COMPONENTS

- A. Electro-mechanical Subsystem
 - 1. Electric Motor
 - 2. Wired Electrical System
- B. Drivetrain Subsystem
 - 1. Speed Reducer
 - 2. Chain Drive
- C. Pneumatic Subsystem
 - 1. Linear Actuator
 - 2. Pressure Regulator
 - 3. Manual Air Valve
- D. Machine Controls

III. MACHINE OPERATION

- A. Safety Features
- B. Pre-start Checklist and Procedure
- C. Start-up Procedure
- D. Shut-down Procedure

IV. MACHINE MAINTENANCE

OVERVIEW

MACHINE DESCRIPTION

The Master Abrader is a high RPM, constant tension, chain drive machine based on the final drive of a Honda CRF450 motorcycle which is specifically designed to cause wear on motorcycle sprockets at an accelerated rate. The chain drive is powered by an electric motor and maintained at a constant tension throughout the duration of its operation using the force exerted by a pneumatic linear actuator.

MACHINE PURPOSE

The objective of the Master Abrader machine is to provide an expedient and effective means to test the long term wear characteristics of sprockets comprised of a variety of materials including, but not limited to, steel, aluminum, and fiber-reinforced composites by subjecting them to high intensity tests so that the individual performance of each material may be directly compared both qualitatively, and quantitatively. The wear, though occurring at an accelerated pace, is intended to be similar in nature to what would be experienced by a sprocket in service on an actual motorcycle over its lifespan. This quality has two important consequences that allow it to be used to be used as a tool to compare the response of different materials to mechanical wear.

MACHINE EMPLOYMENT

Unlike sprockets in use on motorcycles, which are exposed to loading on the sprocket teeth caused by high chain tension during periods of

acceleration, the Master Abrader generates wear on sprocket teeth by relying on an exceptionally high RPM to generate wear from heightened impact forces that occur between the teeth and chain rollers. This approach has the added benefit of increasing the amount of cycles (rotations) a sprocket can be subjected to in a given period of operation, quickening the testing process.

Upon completion of a test cycle, the performance characteristics of a material subjected to wear by contact with the steel rollers on the chain can be evaluated qualitatively by the examination of the types of degradation, or wear mechanisms, that occur on the sprocket teeth. Common wear mechanisms are adhesion, abrasion, surface fatigue, fretting, and erosion. Insight into the differences between the performance of materials subjected to long term wear may be gained by determining the dominance of each mechanism in the final worn sprocket teeth.

The differences between various materials may also be evaluated quantitatively by directly comparing their wear rates. Wear rate may be determined by using the Master Abrader to conduct tests of identical duration for sprockets of different materials and then measuring the material loss, be it volume, or mass. In its current form, the chain drive runs at a fixed RPM. This means that tests of equal duration can be compared directly, in each case simulating the same sprocket life.

A basic example of a potential wear rate is;

$$\text{Wear Rate} = Q = \frac{\text{mass lost}}{\text{number of cycles}}$$

$$Q = \frac{\text{mass lost (g, oz, etc.)}}{\text{time elapsed (min)} \times \text{rate of revolution (RPM)}}$$

This is fine for comparing the wear rates of sprockets made from the same material, however, to directly compare sprockets of different materials mass loss must be non-dimensionalized. Mass can be changed to volume by way of the material's density.

Additionally, impact forces between the sprocket teeth and the rollers on the chain are related to the tangential (pitch-line) velocity of the teeth. It is likely that this will influence the aggressiveness of contact fatigue, and other wear mechanisms. Consequently, the wear rate may differ for identical sprockets tested over an identical number of cycles, but at different RPM.

Thus, a more versatile and descriptive measurement of the wear rate may be;

$$Q = \frac{\text{volume lost}}{\text{number of cycles} \times \text{rate of revolution}}$$

$$Q = \frac{\frac{\text{mass lost (g)}}{\rho \text{ (g/mm}^3)}}{\text{time elapsed (min)} \times [\text{Rate of revolution (RPM)}]^2}$$

This rate reflects the influence of speed and material density on the wear rate by providing an amount of volume lost, per cycle, per RPM.

Because the amount of material lost to the wear process will be small in comparison to the number of cycles performed in a test, it may be necessary to express the wear rate as some value multiplied by 10^N where N is a convenient power.

MACHINE COMPONENTS

The main components and features of the Master Abrader will be catalogued here.

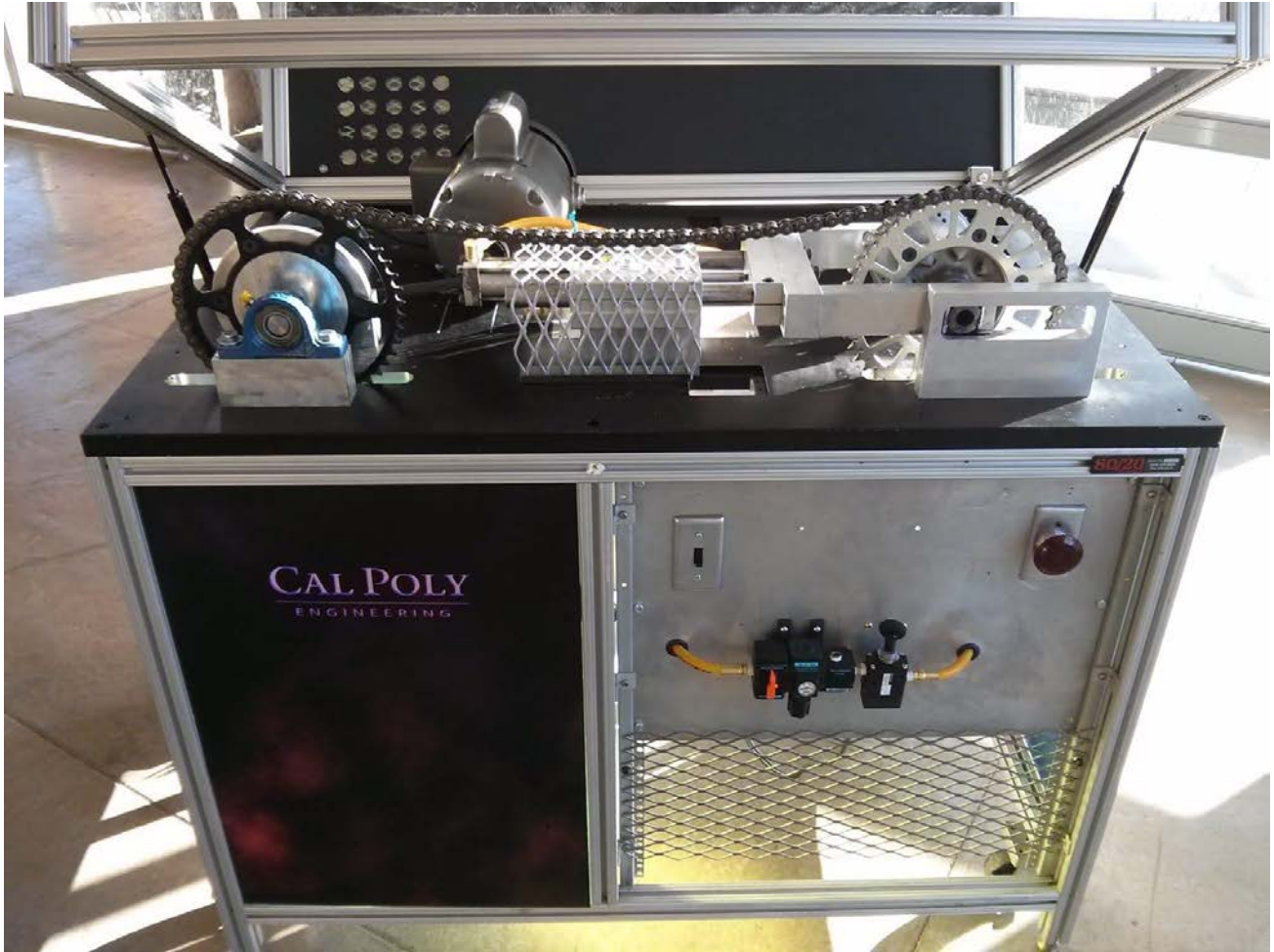

Figure 1. Master Abrader

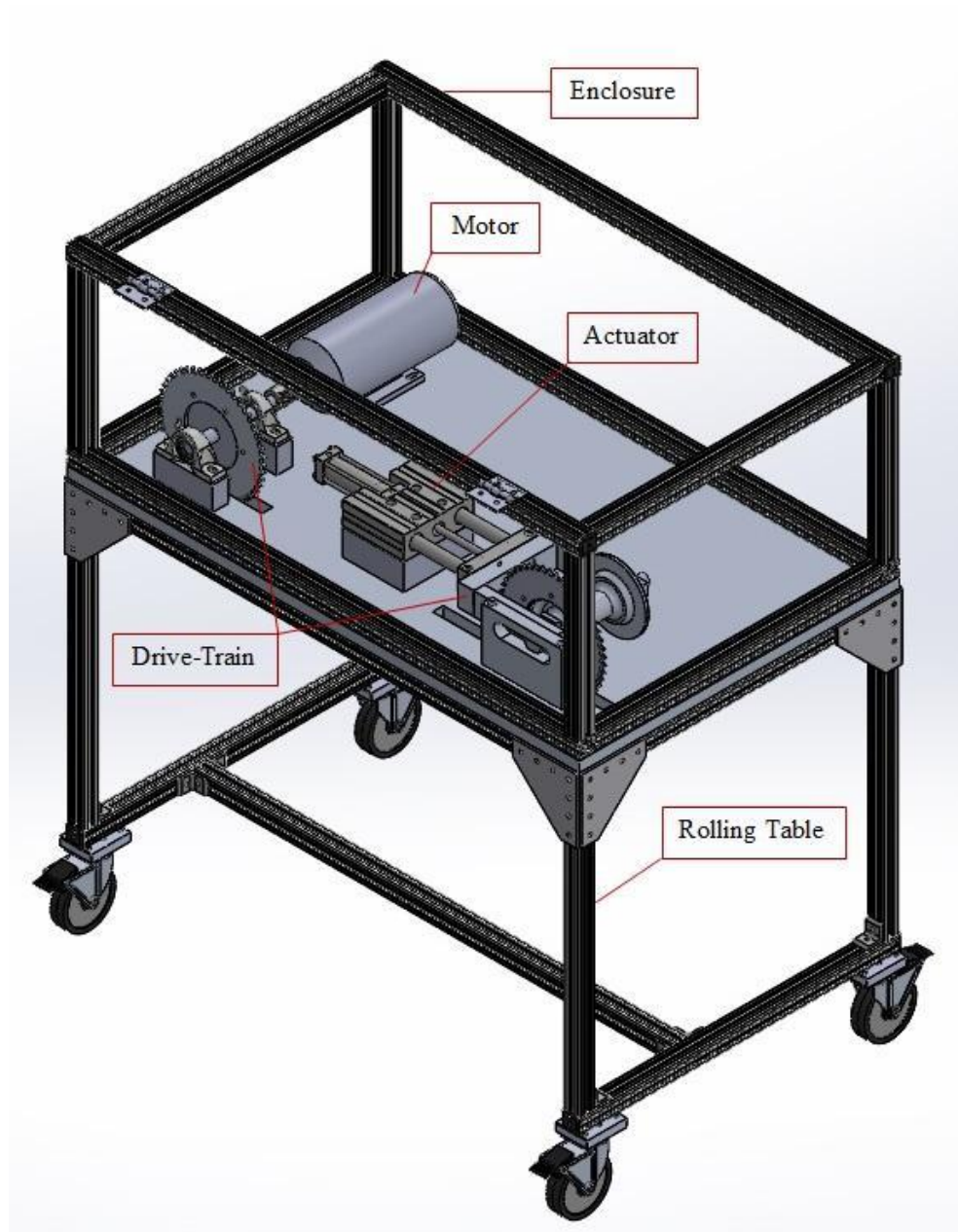

Figure 2. Simplified overview displaying the principal component features of the Master Abrader testing machine.

A more detailed breakdown of the components, classified by subsystem, follows.

ELECTRO-MECHANICAL SUBSYSTEM

1. ELECTRIC MOTOR



Baldor L3513M

Specifications

Shaft Power: 1.5 HP
Shaft Speed: 3450 RPM
Shaft Diameter: $\frac{5}{8}$ inch
*110/220 Volt, 1-Phase
Fully Enclosed & Fan Cooled
Capacitor Start

*The electric motor is wired for 110 volts in its current configuration.

2. ELECTRICAL SYSTEM

- A. Motor Toggle Switch (on/off)
- B. Emergency Stop Switch
- C. Magnetic Contactor Switch
- D. Mechanically Actuated Door Interlock Switch

Wiring Diagram

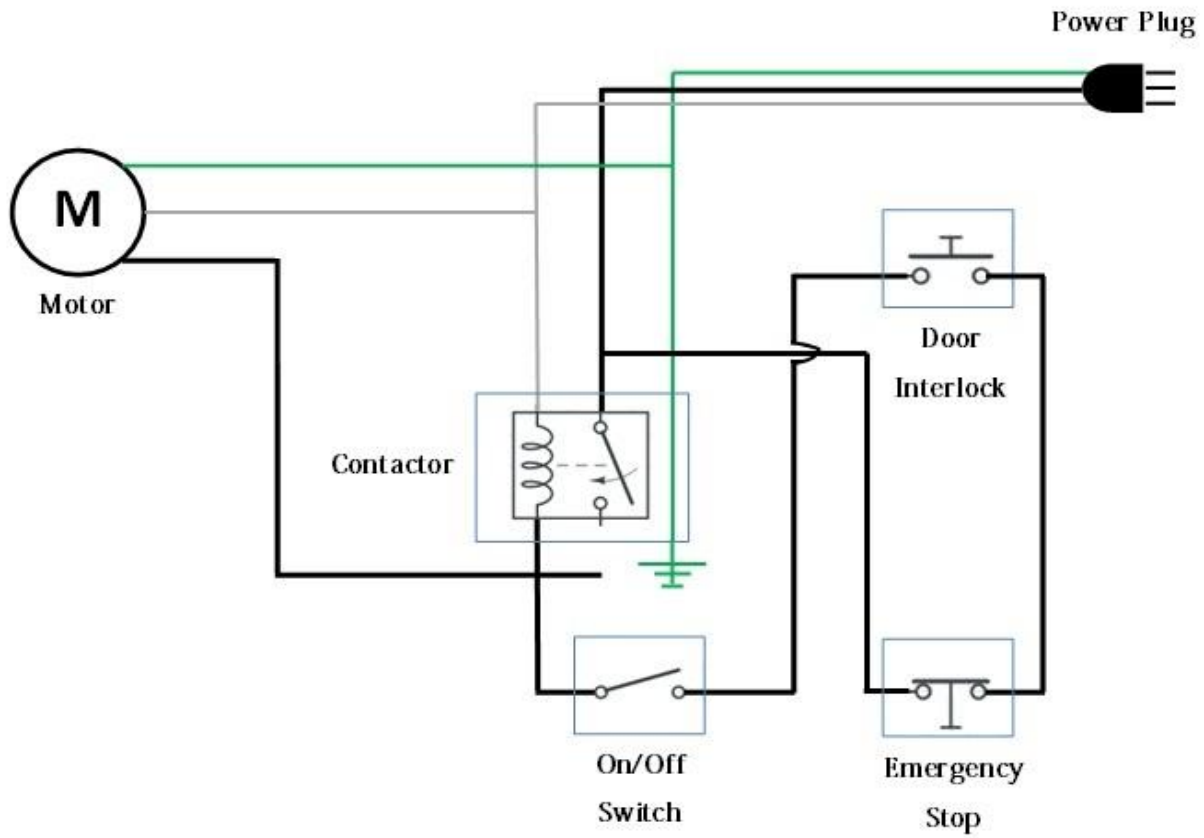

DRIVETRAIN SUBSYSTEM

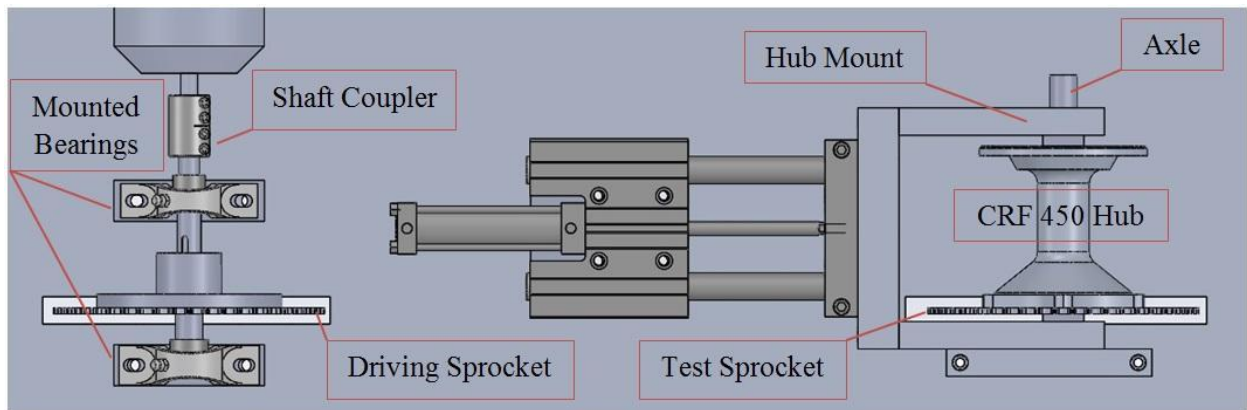

Figure 3. Drivetrain layout without speed reducer

NOTE: SPEED REDUCER NOT PICTURED.

SEE FOLLOWING SECTION FOR DETAILS.

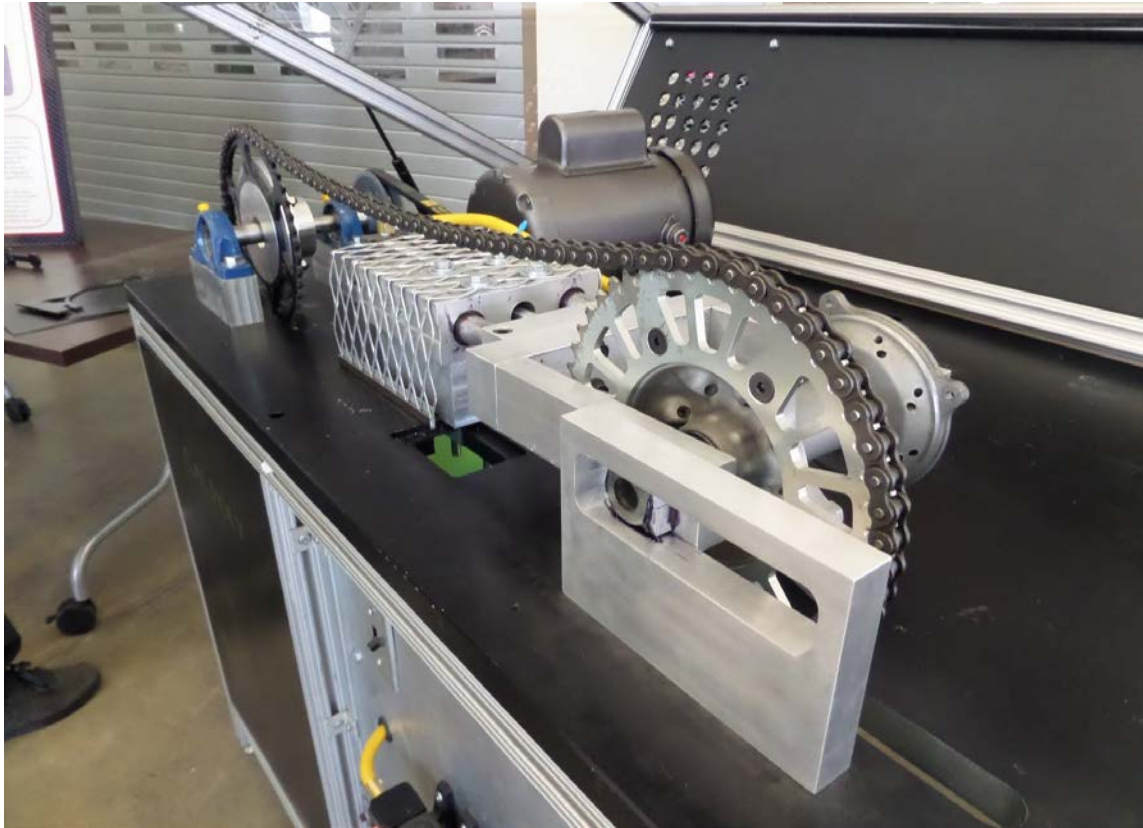

Figure 4. Drivetrain pictured, note offset motor connected to the driveshaft by speed reducer V-belt

1. SPEED REDUCER

The speed reducer is a belt driven pulley stage, with a **ratio** of **2.6:1**, which transfers power from the motor's output shaft to the drive shaft of the chain drive. It's job is to reduce the rotational load seen by the motor by increasing the amount of torque it applies to the drive shaft at the expense of RPM.

Speed reducer is comprised of the following parts.

Belt

Type:	B-section Rubber V-belt
Trade Size:	B24
Length:	27"

Motor Shaft Pulley

Type:	Cast Iron V-belt Pulley
Outer Diameter:	2"
Bore Diameter:	$\frac{5}{8}$ "
Pitch Diameter:	1.7" (Using B-section V-belt)
Key Size:	$\frac{3}{16}$ " Square

Drive Shaft Pulley

Type:	Cast Iron V-belt Pulley
Outer Diameter:	4.75"
Bore Diameter:	$\frac{3}{4}$ "
Pitch Diameter:	4.4" (Using B-section V-belt)
Key Size:	$\frac{3}{16}$ " Square

2. CHAIN DRIVE

Stepped Steel Driveshaft

Minor Diameter:	$\frac{3}{4}$ "
Middle Diameter:	$\frac{7}{8}$ "
Major Diameter:	1"
Key Size:	$\frac{1}{4}$ " Square

Driving Sprocket Holder

Bolt Pattern: OEM Honda CRF450 Rear Sprocket

Drive Shaft Bearings

Manufacturer/Type:	SKF, Ball Bearings
Housing:	Cast Iron Base, Zerk Grease Fittings

Driven Motorcycle Hub & Axle Assembly

Manufacturer/Type:	OEM Honda CRF 450
Hub Bearings:	3 x 6905-RS/2RS

PNEUMATIC SUBSYSTEM

1. LINEAR ACTUATOR

PHD SE Series

Model #: SED 25x4x1-E-H4
Operating Pressure: 20-150 psig (MIN to MAX)
Port Size: 1/8" Pipe Size

2. PRESSURE REGULATOR

Wilkerson

Model #: R26
Operating Pressure: 300 psig MAX
Port Size: 1/4" Pipe Size
Flow Rate: 112 scfm

3. DIRECTIONAL 3-WAY AIR VALVE

McMaster-Carr

Part #: 2700K14
Operating Pressure: 0 - **145** psig (145 psig is system MAX)
Default Position: Normally Closed
Port Size: 1/4" NPT
Flow Rate: 32.5 scfm @ 100 psig

MACHINE CONTROLS



Figure 6. Control Panel Features

- 1) Motor Toggle Switch
 - ON/OFF positions.
- 2) Motor Emergency Stop
 - To engage e-stop, press button in.
- 3) Regulator Bleed Valve
 - Pictured in closed position, allowing air to enter regulator.
- 4) Regulator Pressure Adjustment Knob
 - Read the label
- 5) Directional 3-Way Air Valve
 - To apply chain tension lift plunger.
 - To vent actuator and release tension depress plunger.

MACHINE OPERATION

SAFETY FEATURES

The Master Abrader wear testing machine is built to protect the safety of the operator and those working in the vicinity of the machine by incorporating several safety features in its design. Each safety measure is intended to function as a precaution to minimize the chance of injury should the machine fail mechanically, or should people in contact with the machine commit an error. However, it is important to understand that these features cannot guarantee safety. Ultimately, safety is achieved through intelligent practices.

Impact Shielding

The chain drive is completely enclosed by ¼” thick impact resistant polycarbonate shielding mounted in an aluminum t-slot frame. This is the first line of defence, insulating the dangerous moving parts from those around the machine, and providing a layer of protection should a failure of the chain or pneumatic system occur during operation. An additional measure of protection in the plane of the chain is provided by expanded

steel mesh panels mounted to the outside of the enclosure. The most dangerous area of the machine is the plane of the chain, as any chain failure could result in a whiplash effect in this zone.

Complementing the fully enclosed housing, the length of chain which passes under the table, and the electrical system mounted to the interior side of the control panel are both shielded by ¼” thick acrylic paneling which covers the front and sides of the lower frame to prevent access during operation.

Mechanically Actuated Door Interlock Switch

The motor will not run when the protective polycarbonate enclosure is raised and the chain drive is exposed. This feature is provided by a mechanical switch which prevents power from being supplied to the motor when the enclosure is open. This switch is actuated by an aluminum bracket attached to the inside of the enclosure’s frame. This bracket acts as a “finger” that depresses the interlock switch when the enclosure is lowered and access to the chain drive denied. The switch ensures that the machine will be rendered inoperable should the on-off switch is flipped accidentally while the enclosure is open. Similarly, the machine will automatically shut down if the enclosure is opened during operation, bringing the chain drive to a halt.

Emergency Stop Button

No piece of self respecting machinery would be complete without a big red button. The Master Abrader has one located in easy reach on the control panel should trouble arise. Its function should be self explanatory.

PRE-START CHECKLIST & PROCEDURE

CAUTION!

**REMOVE POWER AND HIGH PRESSURE AIR SUPPLY TO MACHINE
BEFORE PERFORMING ALL PRE-START CHECKS**

MAKE IT SAFE!

- 1) Place air valve plunger in the **down position**, this will vent the actuator cylinder and release any pressure inside.
- 2) Open the enclosure. It should remain open on its own, supported by the pistons on either side.
- 3) Remove the old chain. The chain may be disconnected by removing the clip that retains one of the plates on the master-link. This will allow the master-link to be separated and removed, breaking the chain. A master-link can be identified by the presence of this retaining clip as well as the lack of flared heads on the pins.
- 4) Check that the linear actuator moves freely by pushing and pulling the swing-arm that holds the motorcycle hub back and forth. Ensure that there is a thin layer of grease on the actuator piston rods, add grease if not.
- 5) Remove the motorcycle hub from the swing-arm assembly by loosening the axle nut and pushing the axle towards the front of the machine, it should pass through the guide slot that is fixed to the table top.
- 6) Check that the axle is not marred and free of any damage. Replace axle if damaged.
- 7) *Ensure there is a visible, and evenly distributed amount of grease on the axle. If the axle requires grease refer to the "Greasing the Axle" entry in the Maintenance Section.*
- 8) If a new wear test is to be conducted, remove the old sprocket from hub and replace with the new sprocket that is to be tested.
- 9) Re-install the hub-axle assembly onto the swing-arm, tightening the axle bolt firmly.
- 10) If a new wear test is to be conducted, install an unused length of *520 motorcycle chain with 70 links, it should measure about 90 inches. The master-link for connecting the chain is not included in this length.* This is the length of chain that the machine is designed to use. A shorter length of chain may not fit properly and longer lengths pose a serious derailment hazard should the actuator reach full extension during the test.

- 11) Check the tension and alignment of the V-belt on the speed reducer. The belt should be taught, with minimal give when pressure is applied to the belt by hand. Insufficient tension may cause the belt to slip, or worse, to jump one of the pulleys during operation. If the belt is not refer to the "Tensioning & Aligning the Speed Reducer Belt" entry in the Maintenance section for more information.
- 12) Rotate the chain drive manually, turning the motorcycle hub by hand. Check that it rotates smoothly, without extreme resistance or binding.

START-UP PROCEDURE

Complete all pre-start checklist items and procedures before each test.

- 1) Lower the enclosure.
- 2) Connect the compressed air line to a shop air system, normally 80 to 120 psi MAX.
- 3) Check that the plunger on the air valve is in the down position.
- 4) Open the bleed valve on the pressure regulator by moving the orange switch to the down position. The regulator may hiss as the pressure inside is normalized to that of the shop system.
- 5) Unlock the regulator's pressure adjustment knob by pulling down on it, it should pop down into place. Now the knob may be turned freely.
- 6) Using the knob, adjust the regulator pressure between 40 to 60 psi. The system is rated to a maximum of 145 psig, however there is currently no pressure gauge present capable of reading past 60 psig so exceeding this pressure is not advised. Pressures below 40 psig do not supply sufficient tension to the chain to prevent derailment. Absolute, minimum actuator pressure is 20 psig for any movement to occur.
- 7) Pressurize the pneumatic actuator cylinder by raising the plunger on the manual air valve. This will add tension to the chain. **THIS MUST BE DONE BEFORE STARTING THE MOTOR.**

- 8) Listen for any leaks in the air lines, making sure that the pressure reading on the regulator gauge is stable.
- 9) With the toggle switch (light switch) off, and the emergency stop depressed all the way, plug in the machine to a 110v outlet.
- 10) Disengage the emergency stop by pulling it out away from the panel.
- 11) The machine is now live and ready to start. Flipping the toggle switch will start the motor.

SHUT-OFF PROCEDURE

CAUTION!

UNDER NO CIRCUMSTANCE SHOULD TENSION BE REMOVED FROM THE CHAIN PRIOR TO STOPPING THE MOTOR. DOING SO COULD RESULT IN DERAILMENT OF THE CHAIN, DAMAGE TO THE MACHINE, AND EVEN OPERATOR INJURY!

- 1) Turn off the motor first by placing the toggle switch in the off position.
- 2) Press the emergency stop for additional
- 3) Only now is it safe to remove the tension from the chain. Vent the air in the actuator's cylinder by depressing the air control valve plunger.

MACHINE MAINTENANCE

Because each wear test is comprised of such a high number of revolutions, it is important to perform the following maintenance routines after completing each full length test. In some cases it may be necessary to perform these tasks more frequently than once per test.

It is best to observe the machine with diligence during operation and detect potential issues before they have a chance to become serious problems.

Often your ears can detect a problem in rotating machinery before your eyes!

Greasing The Motorcycle Axle & Hub Assembly

- 1) This grease must be suitable for use in high speed and temperature applications. Purpose correct, high temperature (300+ °F upper operating limit) synthetic greases intended for bearings are recommended. Mobil 1 Synthetic Grease is a good starting point.
- 2) Coat the axle in a film of grease using a brush or your fingers, being careful to spread it evenly.
- 3) Ensure that the surfaces inside of the hub which contact the axle, such as the inner races of the hub bearings, and the aluminum spacers, are well greased. Apply more grease if they are not.
- 4) Apply more grease if there is any doubt. Grease is your friend.

Greasing Driveshaft Bearings

- 1) This grease must also be suitable for high temperature and speed applications.
- 2) Using the appropriate Zerk compatible grease gun, inject grease into the Zerk fittings on the drive shaft bearings. *Only stop applying grease when excess grease begins to ooze out from between the bearing races.*
- 3) *It is important to grease the bearings after every full length wear test, before a new test is begun.*

Tensioning & Aligning Speed Reducer Belt

- 1) This task is accomplished more easily by two people working together, one with a wrench and one to apply tension to the belt.

- 2)** The speed reducer V-belt can be tensioned by loosening the motor mounting bolts enough to slide the motor freely.
- 3)** Now with the belt inside the v-groove on both pulley's, one person applies tension to the belt by sliding the motor to remove slack from the belt. It is important to apply as much tension as possible, this method is difficult and it may be easy to leave the belt under tensioned.
- 4)** When the belt is under tension the second person is to snug the motor mounting bolts so that the other may release the motor.
- 5)** Inspect the belt, it should be aligned so that it is parallel to the chain, with the v-grooves in both pulleys in line with one another.
- 6)** If the belt is properly aligned, fully tighten the motor mounting bolts. If not, loosen them and re-attempt.