

Second Generation Design of an Operator Independent Teflon Coating Adhesion Tester for
Coronary Guidewires

A Senior Project

presented to

the Faculty of the Materials Engineering Department

California Polytechnic State University, San Luis Obispo

In Partial Fulfillment

of the Requirements for the Degree

Bachelor of Science

By

Garrett Wong

June 2014

© 2014 Garrett Wong

Acknowledgments

I would like to thank my senior project sponsor Abbott Vascular for providing me with the samples and equipment to make this project possible. The numerous contacts at Abbott: specifically John Simpson, Matt Gillick, and Jeff Dooley. I would also like to thank my senior project advisor Dr. Blair London for guidance throughout the course of the project.

Abstract

A previously built prototype measurement device was modified to remove operator dependency and produce stability over time. The device is used to determine the relative adhesion of the Teflon coating on stainless steel coronary guide wires. The prototype test involved repeated application of a shear force along the length of wire sample and controlled increases in the force until a breach in the coating was detected. The new design incorporates automation using pneumatic and electric actuators to control the force application on the wire. Three wire samples were tested each at different stages in the guide wire manufacturing process. A One-way ANOVA yielded an F test statistic of 85.17 and a corresponding p-value of 0.00 indicating the new design is able to detect significant difference between the three wire types. Further testing showed that test operator and day at which the test was run yielded high p-values of 0.372 and 0.679, respectively, making them insignificant factors in the measurement system. The majority of the unknown variation can be attributed to variability of the measurement device/process and actual inherent difference in the wire samples.

Keywords: Materials Engineering, guidewire, Teflon, design of experiments

Table of Contents

Acknowledgements.....	ii
Abstract.....	iii
List of Figures.....	v
List of Tables.....	vi
1.0 Introductions.....	1
1.1 Problem Statement.....	1
1.2 Coronary Artery Disease.....	1
1.3 Coronary Angioplasty.....	2
1.4 Guidewires.....	3
1.5 Teflon Coatings.....	5
1.6 Mechanism of Coating Adhesion.....	5
1.6.1 Physical Aspect.....	5
1.6.2 Chemical Aspect.....	6
1.7 Mechanical Actuators.....	6
1.8 Manufacturing Process.....	7
1.9 Preliminary Prototype.....	7
2.0 Materials and Methods.....	9
2.1 Actuators.....	9
2.2 Pressure Regulator.....	9
2.3 Continuity Tester.....	10
2.4 Wire Samples.....	10
2.5 Testing Procedure.....	11
3.0 Experimental Design.....	12
3.1 Pilot Study.....	12
3.2 Main Experiment.....	12
4.0 Results.....	15
4.1 Pilot Study.....	15
4.2 Main Experiment.....	16
5.0 Discussion.....	17
6.0 Conclusions.....	19
7.0 References.....	20
Appendix I.....	21
Appendix II.....	22

List of Figures

Figure 1 - An example of restricted blood flow from the buildup of cholesterol and fat in the artery¹.

Figure 2 - A diagram simulating an inflated balloon catheter during a coronary angioplasty⁴.

Figure 3 - The three main components of a guide wire: distal tip, core, and coating. Wire A utilizes a longer distal tip with a longer section of tapering on the core giving it increased flexibility⁵.

Figure 4 - (A) Interface of a smooth surface and coating. (B) Interface of a rough surface and coating displaying mechanical interlocking. (C) Interface of a surface with high roughness displaying incomplete penetration of coating into crevices⁹.

Figure 5 - Coating adhesion tester designed by Danielle Dunham during her senior project¹².

Figure 6 - Side view of the new model with no pressure being applied (left). If pressure is applied to the pneumatic actuator a teeter totter effect occurs applying a force onto the wire (right).

Figure 7 - Schematic of the test set-up illustrating the placement of the continuity tester leads.

Figure 8 - Schematic of the testing procedure. The pressure will be incrementally increased by 0.5 psi until a breach in to coating is detected.

Figure 9 - Display of the design of experiments. Each operator would test five replicates of each wire type. The testing would be replicated on Day 2.

Figure 10 – Schematic demonstrating the difference between accuracy and precision. The main experiment will be focusing on achieving both high accuracy and precision.

Figure 11 – Box plot displaying the relative averages, variances, and maximum/minimum observations between the three wire types.

Figure 12 – Box plot displaying the relative averages, variances, and maximum/minimum observations between wire type, operator, and day.

Figure 13 – Summary of total variation from the process variability (wire type) and measurement variability (operator, day, error term).

Figure 14 – Breakdown of the all the sources of variation in the measurement system.

List of Tables

Table I - Key Characteristics for the Application of a Guidewire⁶

Table II - Table II – Tukey Pairwise Comparison Letters Grouping

Table III - ANOVA table for the Three Factors of Interest: Wire Type, Operator, and Day

1.0 Introduction

1.1 Problem Statement

Coronary guidewires are single-use medical devices used to assist in the delivery of therapeutic devices during minimally-invasive procedures. The guidewires are coated with Teflon to enhance lubricity within the human anatomy as well as reduce friction with other medical devices. Good adhesion levels are needed between the coating and substrate to prevent the coating from flaking off. A quantitative test was needed to determine if the adhesion level was sufficient in the beginning stages of the wire processing before additional value was added to the wire. The issue was previously addressed in the senior project by Danielle Dunham at Cal Poly State University.

The previous project consisted of the design and fabrication of a new testing apparatus to successfully determine a statistically significant difference between normal and poor adhesion levels. Testing performed by Dunham revealed the apparatus had varying results depending on a slider pull rate. This data suggested repeatability of results would be unlikely unless a single operator was used. Elimination of operator dependency would allow the tester to be incorporated into a production line setting. The goal of the present project is to develop a refined apparatus to remove operator-to-operator variability while performing the test.

1.2 Coronary Artery Disease

Coronary Artery Disease is the most common type of heart disease and cause of heart attacks¹. It is caused by the accumulation of excess cholesterol and fat (plaque) on the inner walls of the coronary arteries (Figure 1). Plaque buildup restricts blood flow to the heart and can lead to a heart attack. Treatment options vary depending on the severity of the condition. Some cases can be managed though the use of medication and/or lifestyle changes, while more severe cases must be treated though bypass surgery or a minimally invasive surgery¹.

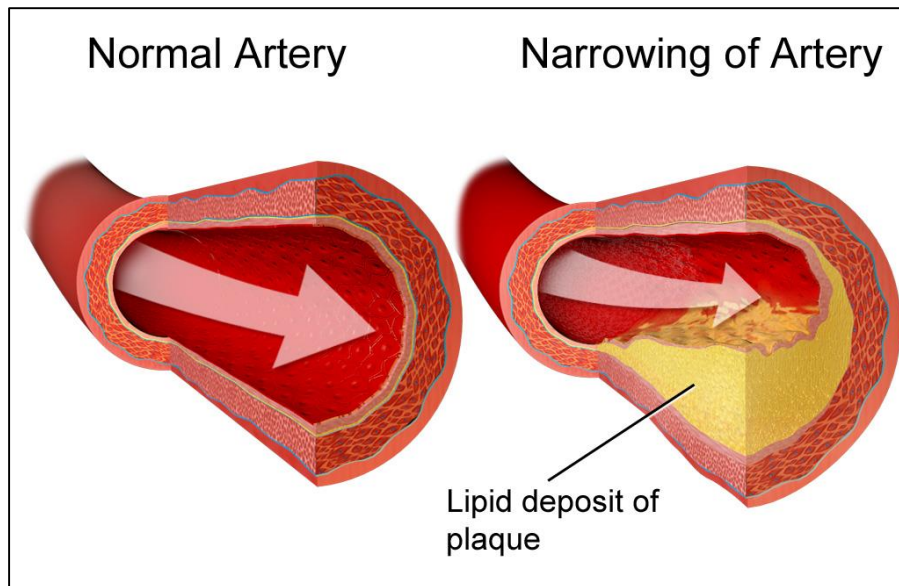

Figure 1 - An example of restricted blood flow from the buildup of cholesterol and fat in the artery¹.

1.3 Coronary Angioplasty

A coronary angioplasty is a minimally-invasive surgery that is performed to open blocked heart arteries. During the procedure, a guide catheter is inserted into the femoral artery and threaded to the mouth of the coronary artery. A small amount of radio-opaque dye is injected through the catheter and imaged with x-rays to guide it to the blocked location. A guidewire is then inserted through the guide catheter to the blockage². Next, a hollow balloon catheter is inserted at the back of the guidewire. The balloon catheter inflates and compresses the plaque into the artery wall and stretches the artery open to increase blood flow³ (Figure 2). In most cases the procedure is followed by the permanent placement of a wire mesh tube called a stent. The stent is left behind to support the new stretched open position of the artery.

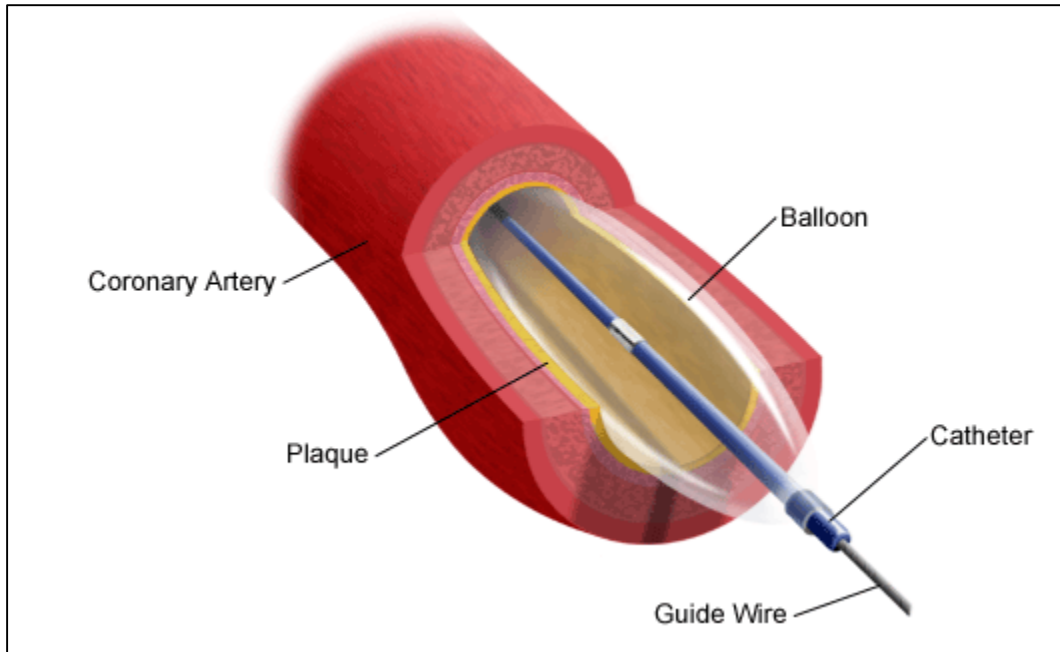

Figure 2 - A diagram simulating an inflated balloon catheter during a coronary angioplasty⁴.

1.4 Guidewires

The appropriate selection of a guidewire is an essential step in the delivery of interventional devices⁵. There are several key characteristics are important in the selection process (Table I).

Table I – Key Characteristics for the Application of a Guidewire⁶

Characteristics	Definition
Torque control	Is an ability to apply rotational force at a proximal end of a guidewire and have that force transmitted efficiently to achieve proper control at the distal end
Trackability	Is an ability of a wire to follow the wire tip around curves and bends without bucking or kinking, to navigate anatomy of vasculature
Steerability	Is an ability of a guidewire tip to be delivered to the desired position in a vessel
Flexibility	Is an ability to bend with direct pressure
Prolapse tendency	Tendency of the body of a wire not to follow the tip around bends
Radiopacity/visibility	Is an ability to visualise a guidewire or guidewire tip under fluoroscopy.
Tactile feedback	Is tactile sensation on a proximal end of a guidewire that physician has that tells him what the distal end of the guidewire is doing
Crossing	Is an ability of a guidewire to cross lesion with little or no resistance
Support	Is an ability of a guidewire to support a passage of another device or system over it

The main components of a guidewire are the core, distal tip, and the outer covering, or coating (Figure 3). The core extends the length of the wire and will begin to taper as it reaches the distal section. The most common core materials are stainless steel and Nitinol and will affect the flexibility, support, steering, and trackability of the entire guidewire. The distal tip can be a one or two piece design. The two piece design is connected using a small piece of metal as a shaping ribbon⁵. Although a two piece design results in a soft flexible tip, these wires have less torque control. The Teflon coating covers the outer surface of the core and acts to reduce friction within the coronary anatomy as well as facilitate movement of other devices over the wire.

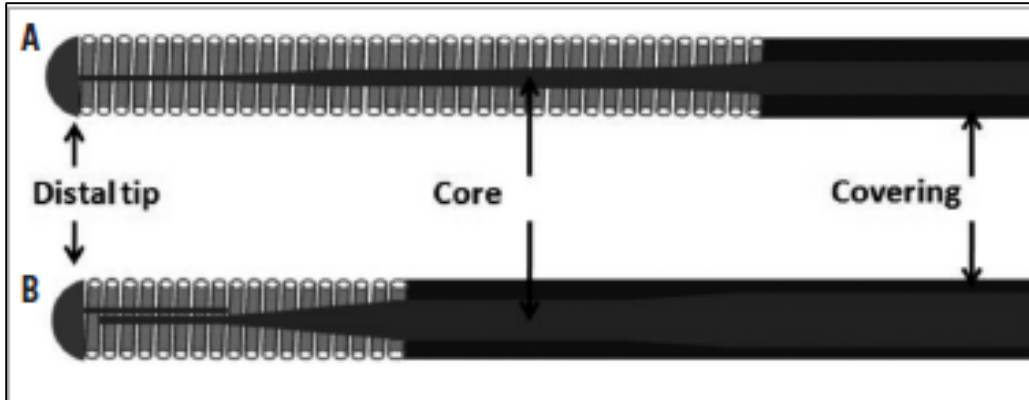

Figure 3 - The three main components of a guidewire: distal tip, core, and covering. The covering in this project addresses a Teflon coating. Wire A utilizes a longer distal tip with a longer section of tapering on the core giving it increased flexibility⁵.

1.5 Teflon Coatings

Polytetrafluoroethylene is a fluoropolymer most commonly known by the name brand Teflon. It is hydrophobic and has one of the lowest coefficient of friction against any solid⁶. It has exceptional resistance to chemical attack, high thermal stability, and is insoluble in solvents⁷. Due to its high thermal stability, PTFE can retain its properties over a wide temperature range. It is a linear polymer with no significant amount of branching. Although it is a thermoplastic it does not show normal melting behavior in the sense of changing to a liquid or readily flowing melt⁸.

1.6 Mechanism of Coating Adhesion

1.6.1 Physical Aspect

In general, adhesion of PTFE usually requires the metal substrate to be roughened. Roughening adds an aspect of mechanical interlocking that increases the resistance to separation of coating and substrate. The concept can be compared to the use of dovetail joints to hold two pieces of wood together. A smooth surface has only the interfacial attractive forces holding the substrate and coating together. On a rough surface two other forces aid in adhesion: the dovetail joint factor and the additional contact area between the coating and the surface. The dovetail factor induces a geometric locking factor that increases the force needed to break the bonds between the coating and substrate. It is important to note that surface roughness can also be a

disadvantage if the coating does not fully penetrate into the microscopic pores and crevices in the surface (Figure 4). This will significantly reduce contact area as well as produce a highly susceptible region for corrosion⁹.

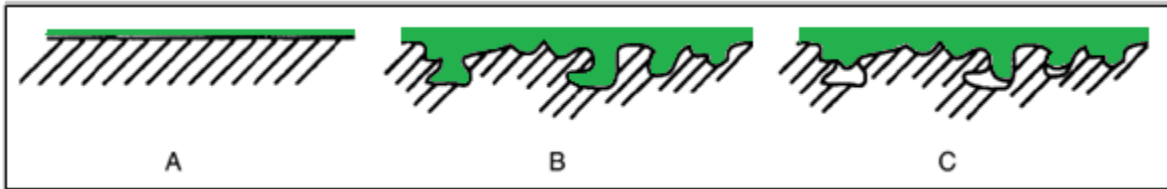

Figure 4 - (A) Interface of a smooth surface and coating. (B) Interface of a rough surface and coating displaying mechanical interlocking. (C) Interface of a surface with high roughness displaying incomplete penetration of coating into crevices⁹.

1.6.2 Chemical Aspect

Wetting is a major, and perhaps limiting, factor in adhesion⁹. Proper wetting allows for a coating to spread over a substrate so that there is intermolecular contact between the coating and substrate. Intermolecular contact is essential for bond formation and adhesion between the coating and substrate. Adhesion is maximized when the coating liquid has a lower surface tension than the surface free energy of the substrate to be coated. If the surface tension of a liquid is too high, a drop of the liquid coating will not spread and will stay as a drop on the surface effectively reducing intermolecular contact.

1.7 Mechanical Actuators

Actuators are a type of motor that converts different sources of energy into motion. Two commonly used types are electric and pneumatic. Pneumatic actuators convert compressed air or gas at high pressure into linear or rotary motion. They work similarly to a piston in which air is pumped inside a chamber and pushed out of the other side of the chamber¹⁰. Pneumatic actuators are advantageous as their source of energy does not need to be stored allowing for quick responses to starting and stopping. Electric actuators convert electrical energy into mechanical torque to rotate a

lead screw that drives a nut resulting in linear displacement¹⁰. Electric actuators offer a wide range of control options and a clean source of energy.

1.8 Manufacturing Process

All guidewires manufactured at Abbott Vascular's facilities go through a general process before being separated into more specific processes based on their medical application. The current project focused on three steps in the manufacturing process: reel-to-reel coating, straightening, and burn-in. The reel-to-reel coating is a single layer film dip process where bare stainless steel is continuously fed through a coating machine containing a furnace. The wire is first pre-treated by the furnace to burn off organic residue. The wire is then continuously fed through a liquid coating formula containing solvents, PTFE particles, chemical activators for promoting adhesion, green pigment, and inert fillers. The wire is treated in the furnace a second time. This reel-to-reel coating process occurs in a time frame of less than one minute.

Next, the straightening process is performed to remove the natural curvature of the wire. In order to accomplish this, the wire is placed under an intensive torsional force. The straightening process is known to negatively impact the Teflon coating adhesion from the torsional stresses introduced into both the stainless steel core and the coating itself. The development of a stress on a coating acts against adhesion and will promote delamination¹¹. After straightening, the burn-in process is performed by placing the batch of wire in a furnace at 750-800°F to allow for the coating to cure. The burn-in process is known to slightly increase the adhesion level between the core and coating. The increase in adhesion is believed to be from the elevated temperatures relieving internal stresses in the wire.

1.9 Preliminary Prototype

The previous design was conceived and built by Danielle Dunham during the 2012-2013 academic year for a Materials Engineering senior project (Figure 5). The prototype consisted of repeated handheld actuation of the wire sample as a smooth cylindrical bar applied a downward force on the sample until a breach in the coating was detected. If no breach was detected, the downward force would be raised by manually

sliding a weight along a lever bar and the process would be repeated until a breach was finally detected. An electrical continuity tester was used to determine when the coating was breached. One test lead was connected to a set screw fixing the cylindrical bar in place, and the other was connected to a section of the wire sample stripped of the coating to expose the bare metal. As the test was performed, an audible indicator would sound when an electric circuit was established between the two leads. The indicator signaled a rupture in the coating when metal-to-metal contact was made between the cylindrical bar and the wire core.

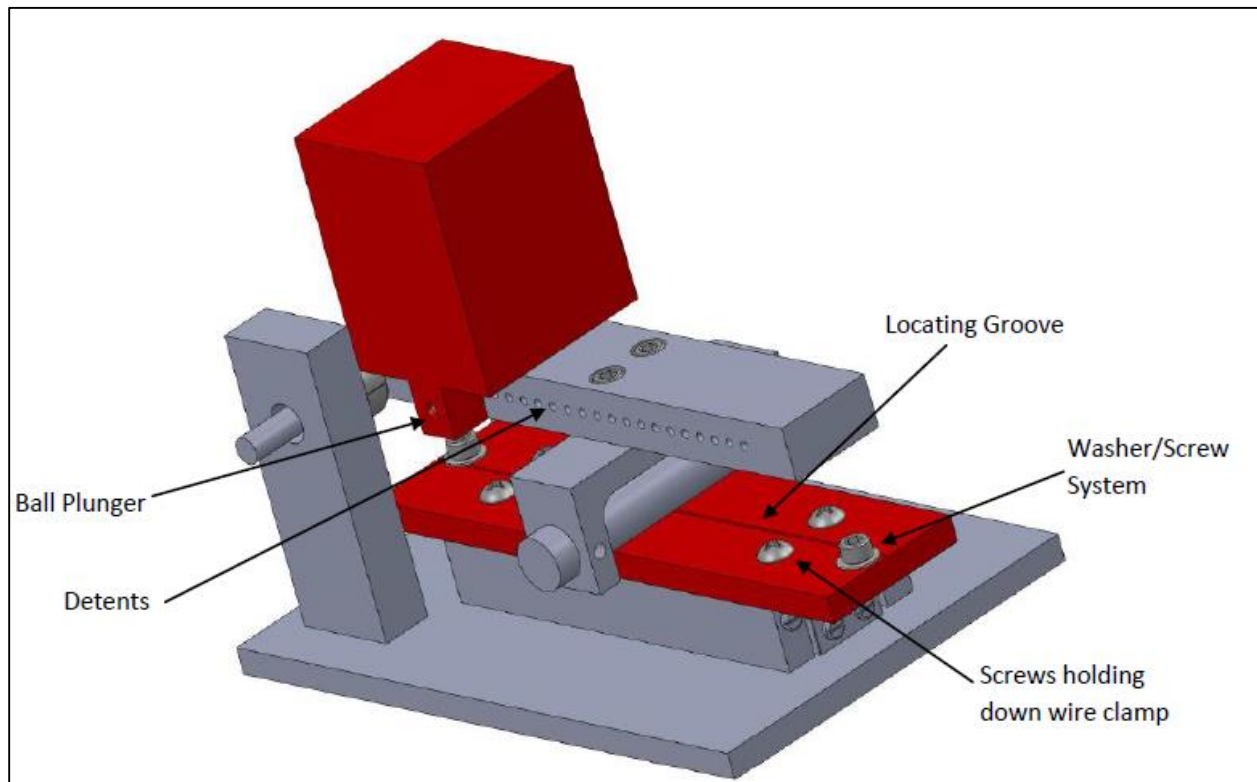

Figure 5 - Coating adhesion tester designed by Danielle Dunham during her senior project¹².

2.0 Materials and Methods

2.1 Actuators

The new device was designed to remove all manual actuation and to maximize motorized automation within the system. In order to achieve this, two different actuators were implemented into the previous device to allow for precise force control on the wire sample (See Appendix I).

An electric actuator was added to the design to automate the motion of the ball bearing slider that housed the wire sample. This would enable a fixed rate of motion as the shear force was being applied along the length of the wire. The electric actuator is powered by a standard 120V outlet and is controlled by a two-button control system.

A pneumatic actuator was added to the design to provide for precision force control on the wire. The Airpel Double-Acting Universal Mount 1" Stroke was selected for the system based on its sensitivity to pressures less than 0.2 psi¹³. The pneumatic actuator would be connected to a compressed air line with an intermediary pressure regulator. As pressure was fed to the actuator, a piston would be extended producing a teeter-totter effect that would apply the force on the wire sample (Figure 6).

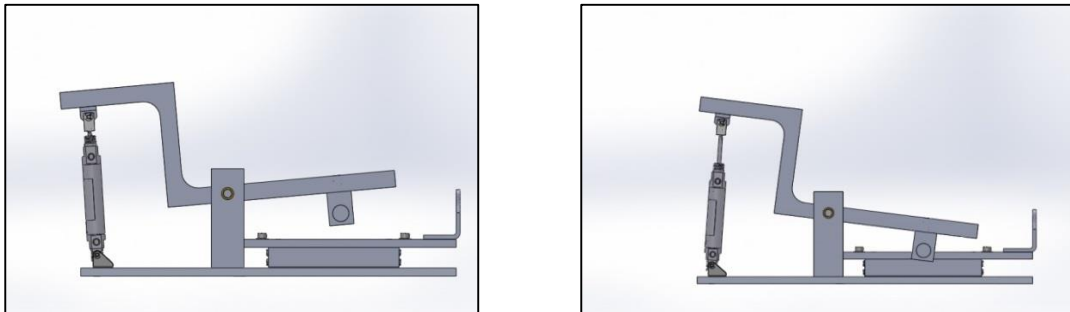

Figure 6 – Side view of the new model with no pressure being applied (left). If pressure is applied to the pneumatic actuator a teeter totter effect occurs applying a force onto the wire (right).

2.2 Pressure Regulator

A pressure regulator was connected between the compressed air line and the pneumatic actuator to regulate air flow. A precision air regulator was selected that

utilized an exhaust vent to deplete excess downstream pressure when the system was blocked. The exhaust vent feature allowed for a higher degree of precision compared to standard regulators. The regulator for the project operated at a regulating range of 2-25 psi.

2.3 Continuity Tester

An electrical continuity tester was used to determine breaches in the coating during testing. One lead of the tester was attached to a set screw holding in the contact cylinder that would apply the shear force on the wire sample. The second lead was connected to one end of the wire sample that had been stripped of its Teflon coating to expose the bare stainless steel wire (Figure 7). The contact cylinder would be dragged back and forth along the length of the wire until it made contact with the stainless steel core of the wire. The metal to metal contact would allow electron flow through the tester and complete a circuit. Once a circuit was detected, the tester would output an audible signal.

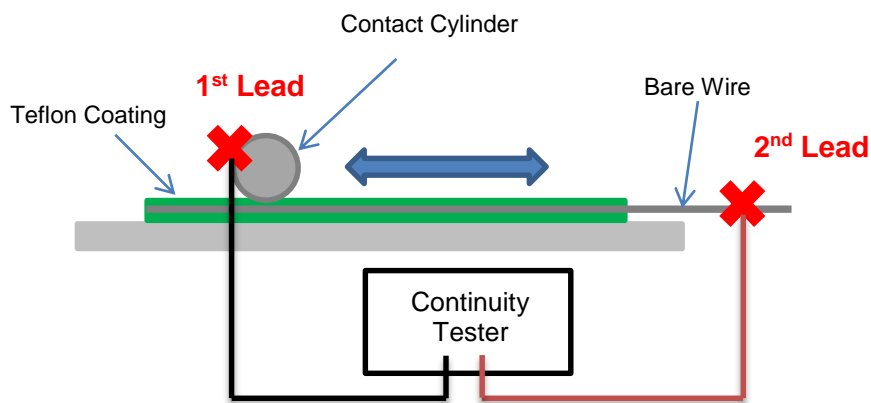

Figure 7 – Schematic of the test set-up illustrating the placement of the continuity tester leads.

2.4 Wire Samples

Four wire types were supplied from Abbott for evaluation; as-coated, straightened, burn-in, and supplier coated. The supplier coated wire utilized a three-coat system with PTFE Lubriskin™ as the topcoat. The three remaining wire types were taken directly after each of its respective processes: post reel-to-reel coating, post straightening, and post burn-in.

2.5 Testing Procedure

The coating adhesion test started with an initial pressure being sent to the pneumatic actuator that correlated to a certain force applied on the wire. The pilot study used an initial pressure of 5.0 psi, but was lowered to 3.0 psi during the main experiment to allow for more cycles at the higher end. After the initial pressure was applied, the electric actuator would automate the slider so the contact cylinder would be dragged along the length of the wire constituting one cycle. The contact cylinder was fixed to restrict its rotational motion; therefore, as the cylinder was dragged, a shear force was applied to the wire. If no breach was detected at the end of one cycle, the pressure would be increased 0.5 psi and the cycle would be repeated. The pressures would be incrementally increased 0.5 psi after each cycle until a breach in the coating was detected by the continuity tester (Figure 8). For a complete test procedure, reference Appendix II.

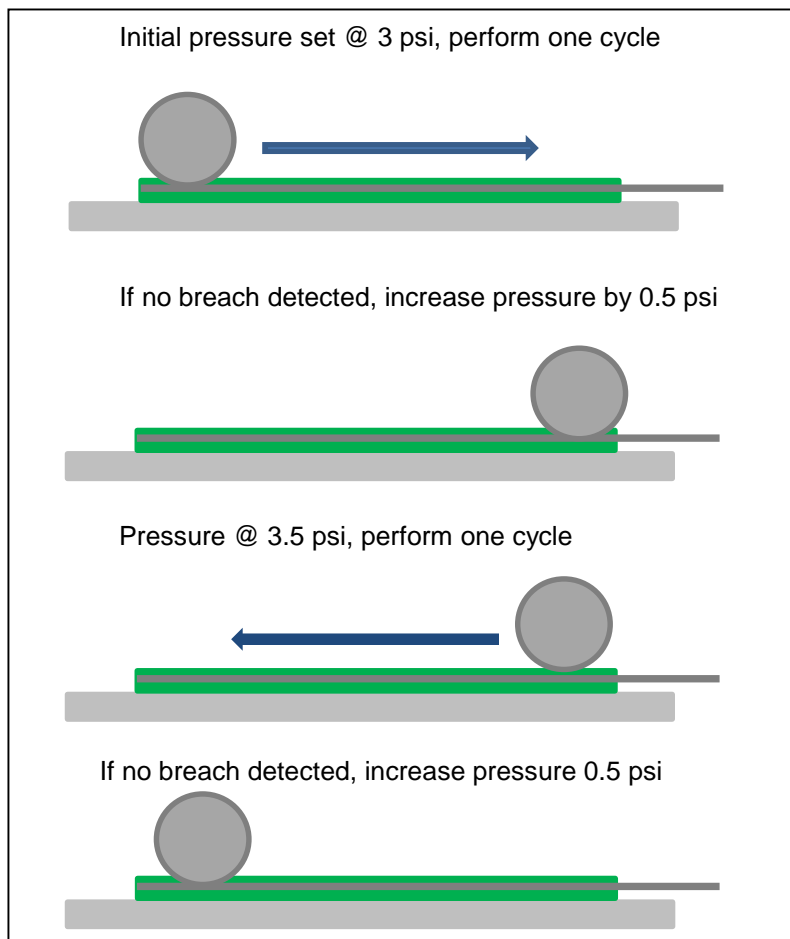

Figure 8 – Schematic of the testing procedure. The pressure was incrementally increased by 0.5 psi until a breach in to coating was detected.

3.0 Experimental Design

3.1 Pilot Study

After the new 2nd generation adhesion tester was assembled, a pilot study was performed using a One-way Analysis of Variance (ANOVA). The goal was to ensure the new design was still capable of determining statistically significant differences between the different wire types and to assess the variability in the test setup. The factor of interest, wire type, was tested against the four wire samples: as-coated, straightened, burn-in, and supplier coated. The run order was randomized using Minitab software.

While performing the experiment, the supplier coated wire went beyond the maximum regulating range of the pressure regulator. The coating needed an additional 30 cycles at the maximum force before the coating was finally breached. After consultation, it was determined to remove the supplier coated samples from the experiment and to rerun the pilot study at three levels.

3.2 Main Experiment

The main experiment was conducted using a mixed effects model based on the measurement systems analysis technique: ANOVA gauge repeatability and reproducibility, or gauge R&R (Figure 9). The treatment structure for the experiment was wire type at three levels (as-coated, burn-in, straightened), operator at three levels (Operator A,B,C), and day at two levels (Day 1,2). The experiment was designed to test that the variation in measurements was insignificant among different operators (reproducible) and insignificant over time (repeatable). The operator factor was added to the design to test for reproducibility among operators, and day was added to test for repeatability over time.

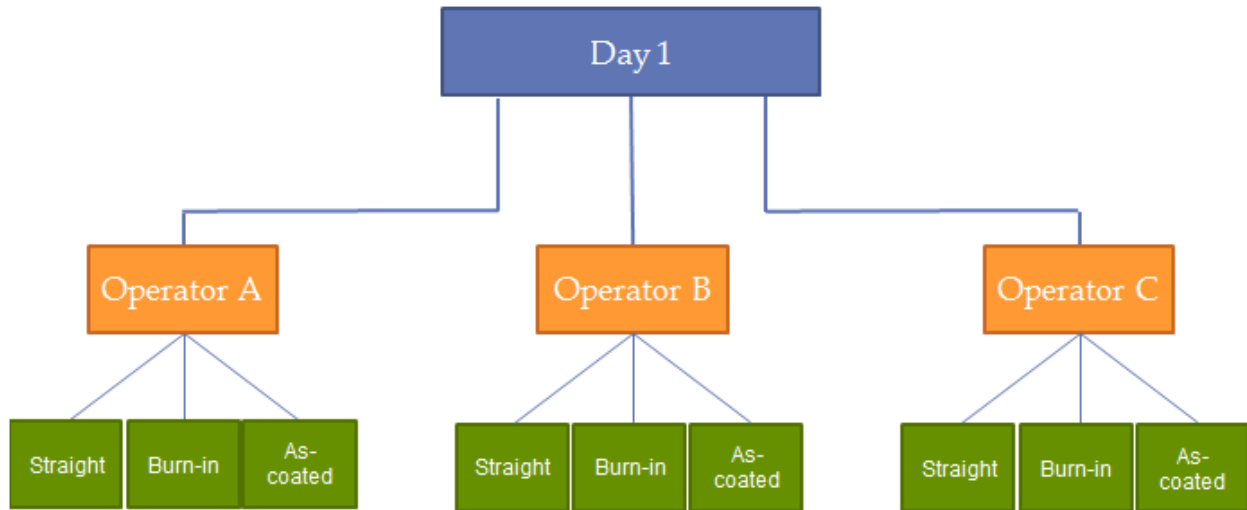

Figure 9 – Display of the design of experiments. Each operator would test five replicates of each wire type. The testing would be replicated on Day 2.

The operator and day factors are inherently different than the wire type factor. Wire type is a fixed effect in which its observed values are assumed to be due to the factor levels. In comparison, the levels of a random effect can be thought of samples from a larger population¹⁴. The hypothesis test for a random effect tests for significant differences in variance, while the hypothesis test for a fixed effect tests for significant differences in means (Equations 1-3).

Wire Type (Fixed)

$$H_0: \mu_{as-coated} = \mu_{burn-in} = \mu_{straightened} \tag{Eq.1}$$

Ha: at least one μ_i differs

Operator (Random)

$$H_0: \sigma^2_{operator A} = \sigma^2_{operator B} = \sigma^2_{operator C} \tag{Eq.2}$$

Ha: at least one σ_i^2 differs

Day (Random)

$$H_0: \sigma^2_{Day 1} = \sigma^2_{Day 2} \tag{Eq.3}$$

Ha: $\sigma^2_{Day 1} \neq \sigma^2_{Day 2}$

H_0 designates the null hypothesis and H_a designates the alternative hypothesis. For the fixed effect, the μ term represents the average for each of the wire types. For the random effects, the σ^2 term represents the variance for each of the operators and days.

Typical gauge R&R studies tests for the precision of a measurement device. This experiment incorporates wire type to test for both accuracy and precision (Figure 10). The fixed effect, wire type, in this experiment will be testing for accuracy, while the random effects, operator and day, will be testing for precision.

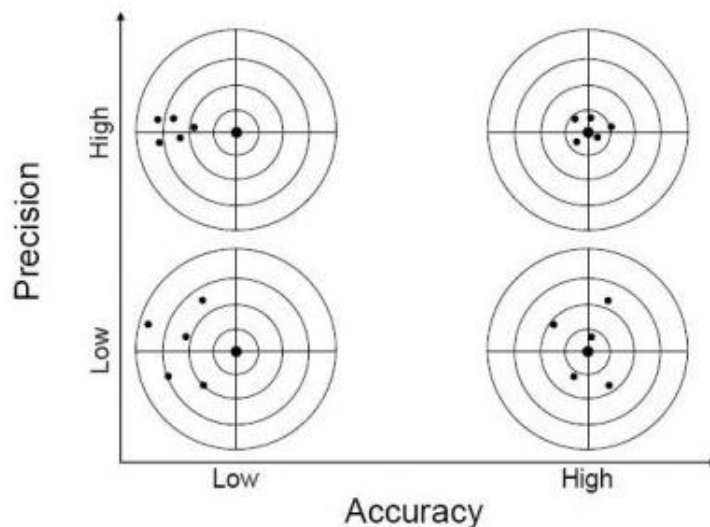

Figure 10 – Schematic demonstrating the difference between accuracy and precision. The main experiment will be focusing on achieving both high accuracy and precision¹⁵.

The run order for each test session was randomized using Minitab. The wire samples were precut and placed into groups of five for each wire type level. The three groupings would then be randomly assigned to each operator on each day. Due to time conflicts with the operators, the session order could not be randomized and was instead completed based on availability in a 24 hour time window.

4.0 Results

4.1 Pilot Study

Five samples of each wire type were tested (Figure 11). The formal statistical test yielded an F-test statistic of 85.17 and a corresponding p-value of 0.000. With a low p-value, the null hypothesis was rejected and the test confirmed that the new design was able to determine statistically significant differences in Teflon coating adhesion levels.

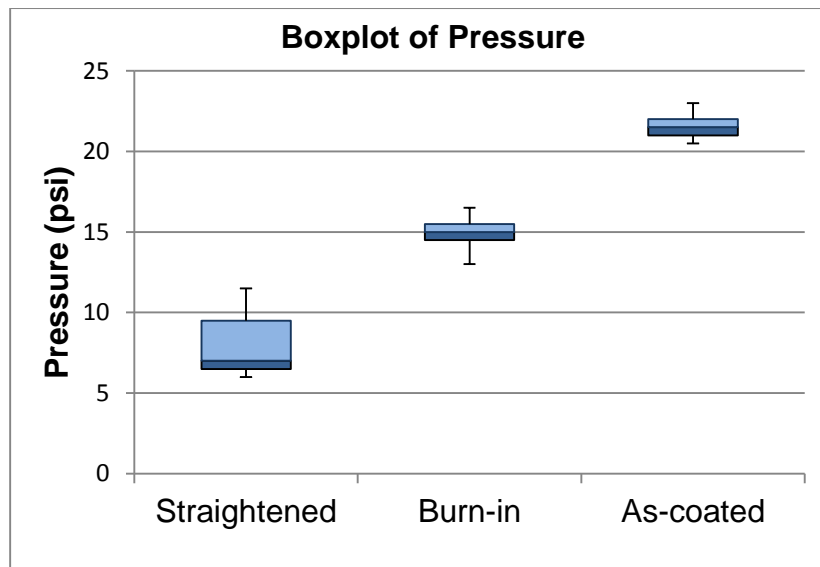

Figure 11 – Box plot displaying the relative averages, variances, and maximum/minimum observations between the three wire types.

The ANOVA test alone only has the ability to detect that there is at least one difference between the wire type levels. In order to determine which levels differed from each other Tukey's Method for Pairwise Comparisons was performed and revealed that each wire type was significantly different from each other (Table II). On average, the as-coated wire samples required the highest pressure at 21.6 psi to breach the coating, and the straightened wire samples required the lowest pressure at 8.1 psi.

Table II – Tukey Pairwise Comparison Letters Group

<u>Level</u>	<u>Grouping</u>			<u>Means (psi)</u>
As-coated	A			21.6
Burn-in		B		14.9
Straightened			C	8.1

4.2 Main Experiment

The results for the main experiment produced similar results to the pilot study with respect to the wire type. Again, the as-coated wire samples required the highest pressure to breach the coating and the straightened wire samples required the lowest average pressure (Figure 12).

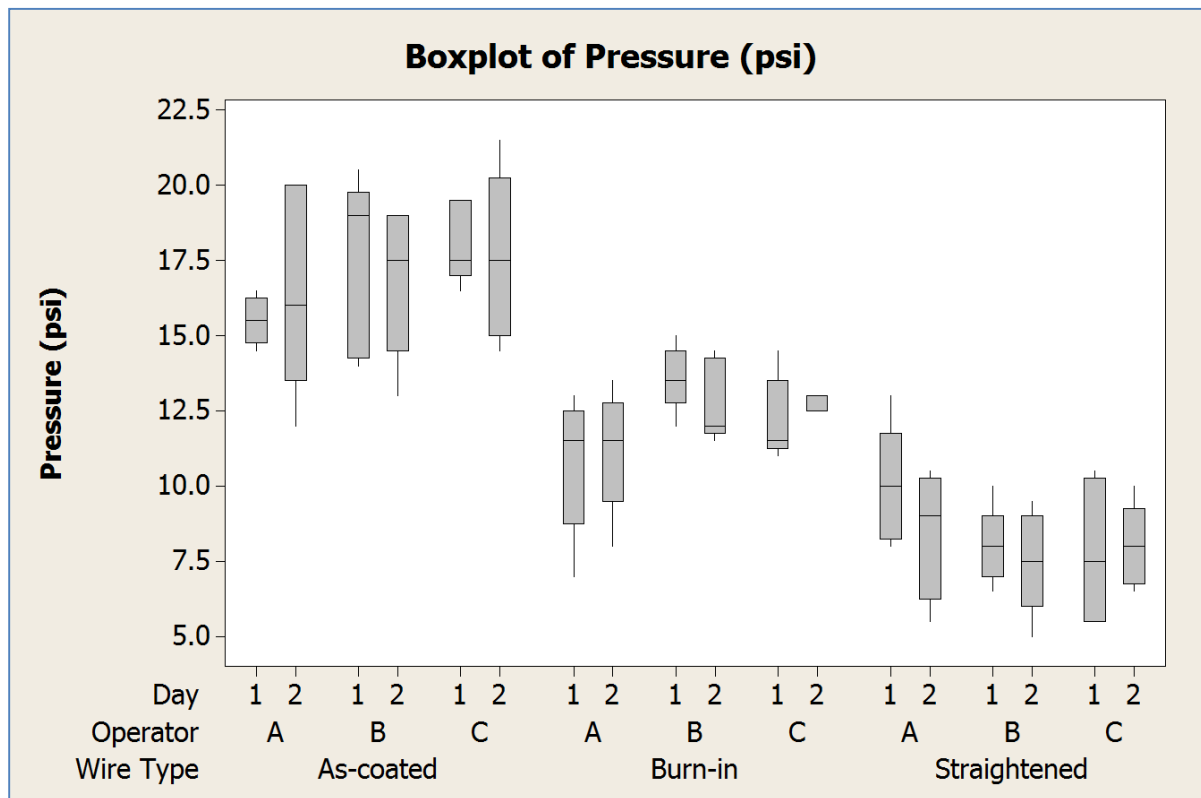

Figure 12 – Box plot displaying the relative averages, variances, and maximum/minimum observations between wire type, operator, and day.

The test for significance of wire type confirmed the results of the pilot study proving to be highly significant. With an F-test statistic of 138.91 and a corresponding p-value of 0.000, the null hypothesis is rejected and it was concluded that wire type has a significant effect on the pressure at which the coating is breached.

The test for the significance of operator produced an F-test statistic of 1.00 with a p-value of 0.372. With a large p-value, it was concluded that the operator to operator variation was not significantly different. The test for significance of day produce an F-test statistic of 0.17 with a corresponding p-value of 0.679 (Table III), it was concluded that the day-to-day variation was not significantly different.

Table III – ANOVA table for the Three Factors of Interest: Wire Type, Operator, and Day

<u>Source</u>	<u>DF</u>	<u>Seq SS</u>	<u>Adj MS</u>	<u>F-Statistic</u>	<u>P-value</u>
Wire Type	2	1147.54	573.77	138.91	0.000
Operator	2	8.27	4.14	1.00	0.372
Day	1	0.71	0.71	0.17	0.679
Error	84	346.97	4.13		
Total	89	1503.49			

5.0 Discussion

The total variation within the system was calculated using the sum of squares and revealed that 76% of the variation can be accounted for in the process variability or the fixed effect, wire type. The remaining 24% of the total variation is attributed to the measurement variability, or the random effects: operator, day, and the error term (Figure 13).

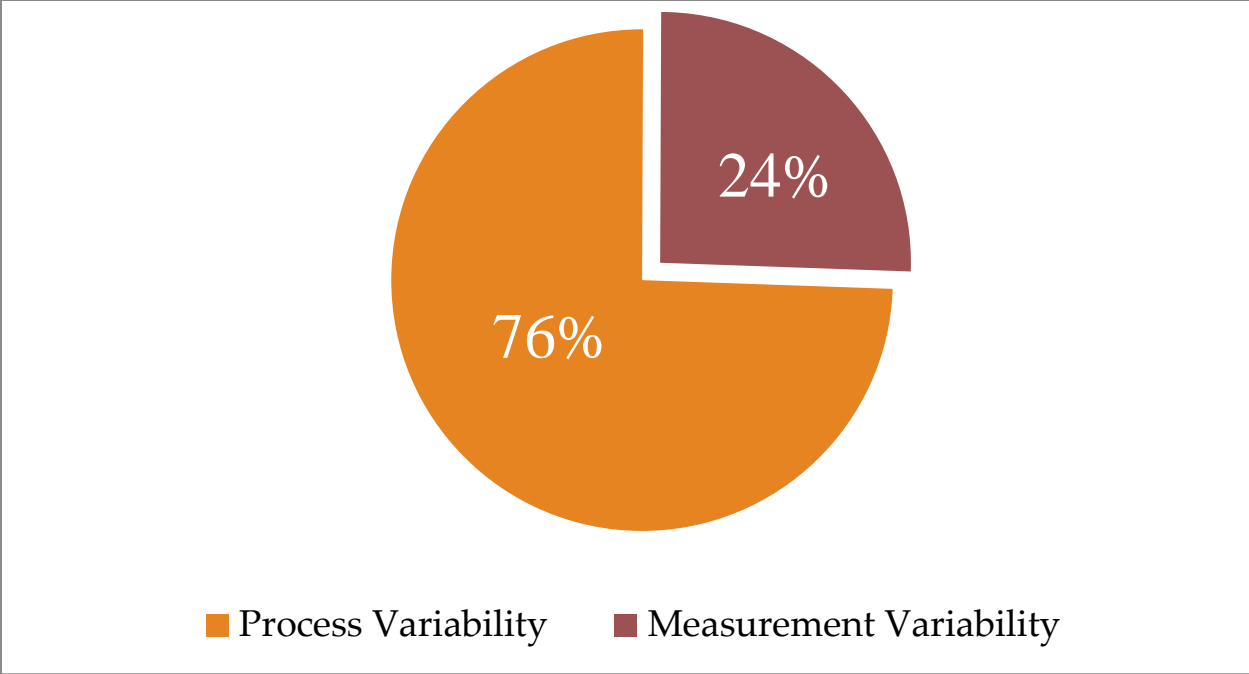

Figure 13 – Summary of total variation from the process variability (wire type) and measurement variability (operator, day, error term).

The combination of the variability for operator and day account for less than 1% of the total variation within the measurement system. The remaining 23% of the variation is attributed to the error term (Figure 14). The error term can be subdivided into three aspects: 1) Natural random variation expected in all experiments. 2) Variability within the new measurement device, either from factors that were not completely controlled or confounding variables. 3) Actual inherent differences in the wire samples. Due to the destructive nature of the test, both factors (2) and (3) will contribute to the majority of the error term. Additionally, since it is impossible to test the same sample twice, there is no set or true known value of the pressure at which the coating is breached. An exact variability of each wire type is therefore, unknown.

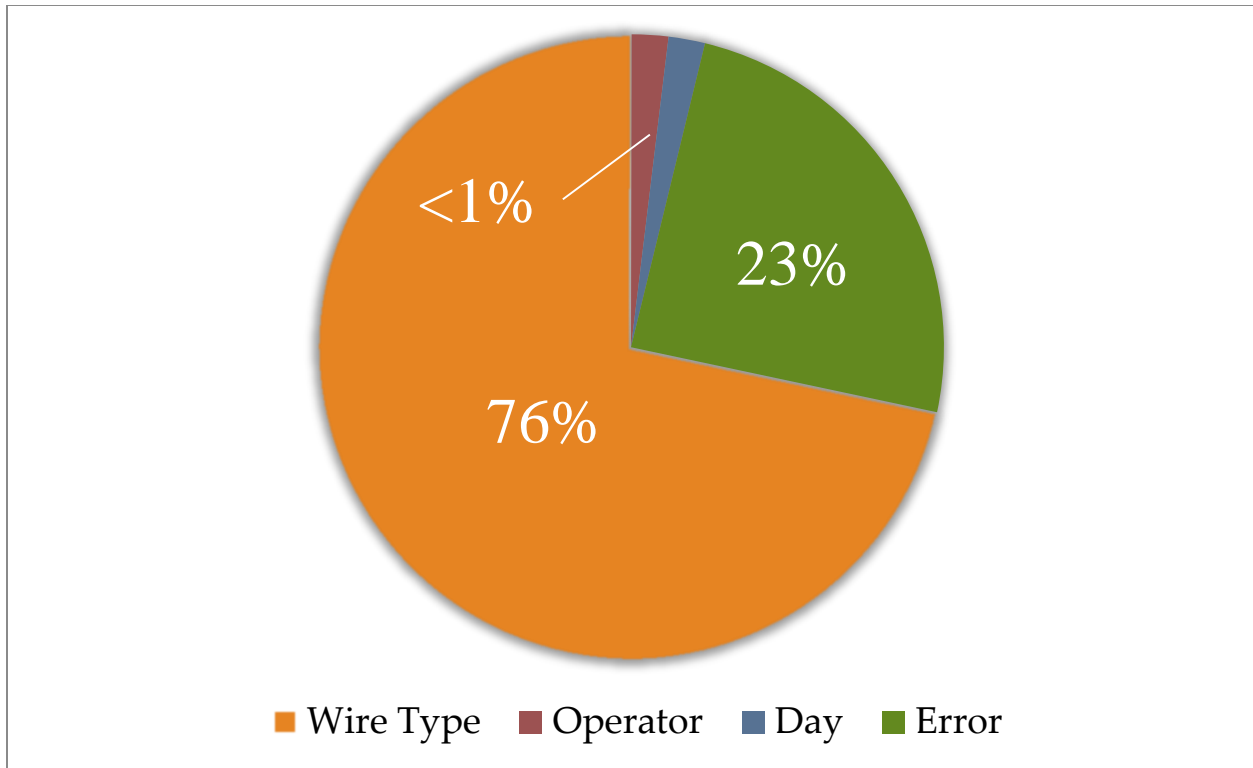

Figure 14 – Division of all the sources of variation in the measurement system. The majority of the variability is attributed to the significant effect Wire Type and the remaining is associated with the error term.

6.0 Conclusions

1. The new device was able to confirm that the wire type has a significant effect on the pressure at which the coating is breached.
2. Test operator and day at which the test was run yielded high p-values of 0.372 and 0.679, respectively, making them insignificant factors in the measurement system.
3. Less than one percent of the variation in the system can be attributed to operator and day, while the wire type accounts for 76% of the variation in the system.
4. The majority of the unaccounted variation can be attributed to variability of the measurement device/process and actual inherent difference in the wire samples.

7.0 References

1. "Coronary Artery Disease." *Wikipedia*. Wikimedia Foundation, 21 Nov. 2013. Web. 29 Nov. 2013.
2. "Percutaneous Coronary Intervention." *Wikipedia*. Wikimedia Foundation, 28 Jan. 2014. Web. 25 Jan. 2014.
3. "Angioplasty and Stents for Heart Disease Treatment." *WebMD*. WebMD, n.d. Web. 20 Oct. 2013. <<http://www.webmd.com/heart-disease/guide/treatment-angioplasty-stents>>.
4. "Percutaneous Transluminal Coronary Angioplasty/Stent Placement." - *Stanford Hospital & Clinics*. N.p., n.d. Web. 25 Jan. 2014.
5. Erglis, Andrejs, Inga Narbutė, and Dace Sondore. "Tools & Techniques: Coronary Guide Wires." *EuroIntervention* (2010): n. pag. *Pconline*. Web. 30 Jan. 2014.
6. "Polytetrafluoroethylene." *Wikipedia*. Wikimedia Foundation, 19 Oct. 2013. Web. 20 Oct. 2013. <<http://en.wikipedia.org/wiki/Polytetrafluoroethylene>>.
7. Saunders, K. J. *Organic Polymer Chemistry: An Introduction to the Organic Chemistry of Adhesives, Fibres, Paints, Plastics, and Rubbers*. London: Chapman and Hall, 1988. Print.
8. Saunders, K. J. *Organic Polymer Chemistry: An Introduction to the Organic Chemistry of Adhesives, Fibres, Paints, Plastics and Rubbers*. London: Chapman and Hall, 1973. Print.
9. Wicks, Zeno W. *Organic Coatings: Science and Technology*. Hoboken, NJ: Wiley-Interscience, 2007. Print.
10. "Linear Actuator." *Wikipedia*. Wikimedia Foundation, 15 Jan. 2014. Web. 31 Jan. 2014.
11. Perera, Dan Y. "On Adhesion and Stress in Organic Coatings." *Progress in Organic Coatings* 28.1 (1996): 21-23. Web.
12. Dunham, Danielle. "Development of a Production Line Appropriate Test for Teflon Adhesion on 304 Stainless Steel 0.01-0.03" Diameter Coronary Guide Wires, Senior Project, California Polytechnic State University, 2013.
13. "Double-Acting." *Customizable Pneumatic Actuators, Dashpot & Snubber Experts*. N.p., n.d. Web. 10 June 2014. <http://www.airpot.com/inch-double-acting-c-15_16_17_18-l-en.html>.
14. Oehlert, Gary W. *A First Course in Design and Analysis of Experiments*. New York: W.H. Freeman, 2000. Print.
15. Precision vs. Accuracy. Digital image. *Triclawps*. N.p., n.d. Web. <<http://www.triclawps.com/accuracy-v-precision/>>.

Appendix I

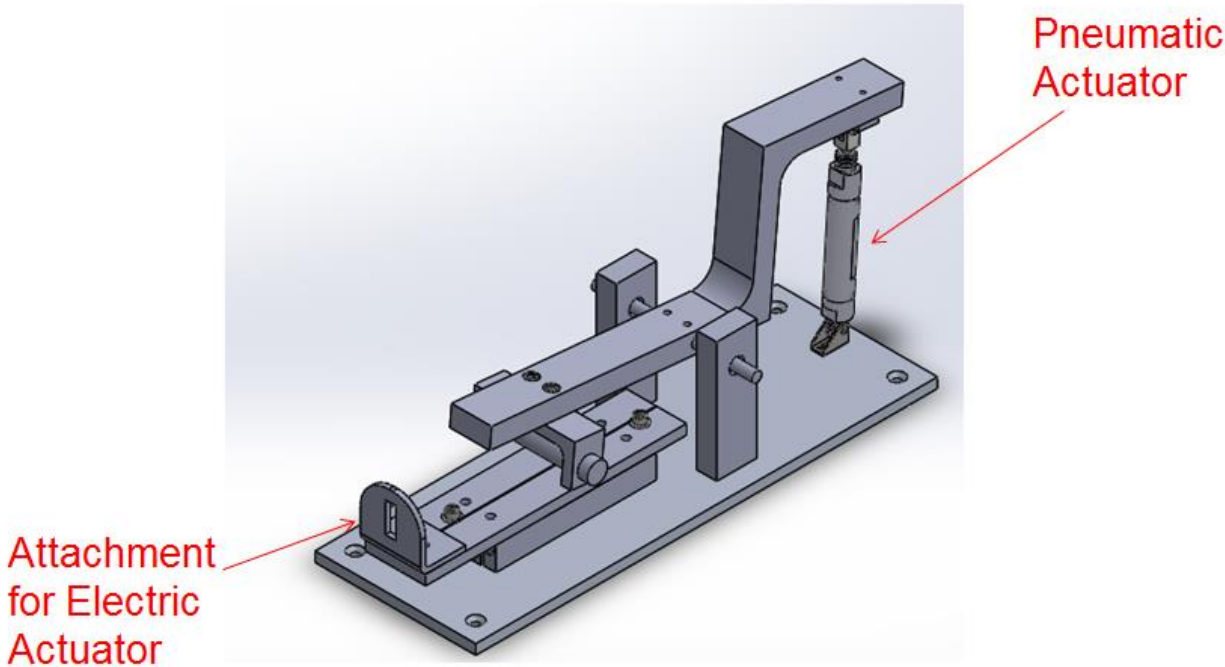

Appendix II

1. Definitions*

Term	Definition
Adhesion	The ability of two materials clinging to each other.
Continuity Tester	An electrical device that detects when an electrical circuit can be made. For example, when there is metal-to-metal contact between its leads.

2. Equipment, Tooling & Supplies

- Coating Adhesion Tester
- Pneumatic Actuator
- Electric Actuator
- Pressure Regulator
- Pressure Switch
- Continuity Tester
- Wire Stripper
- Wire Cutter

3. Guidelines* (STM/TI)

None.

4. External References* (STM/TI)

None.

5. Test Overview* (STM/TI only)

This test will provide a measurement for the adhesion of Teflon on stainless steel wire. If the wire batch has reached its required value it can be continued down the manufacturing line, if not, it will be scrapped.

6. Equipment Setup/ Sample Preparation (LTM only)

Equipment Setup*:

1. Thread in rod to the front end of the electric actuator.



2. Attach the other end of the rod to the L bracket using two nuts and two washers.

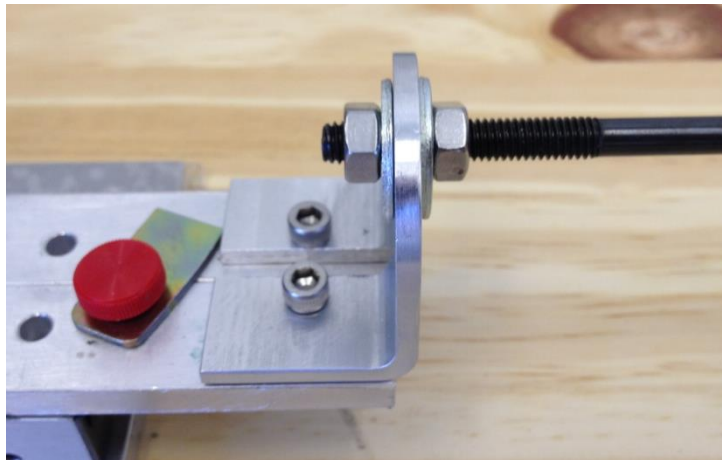

3. Remove contact cylinder by loosening the two set screws holding it in place.

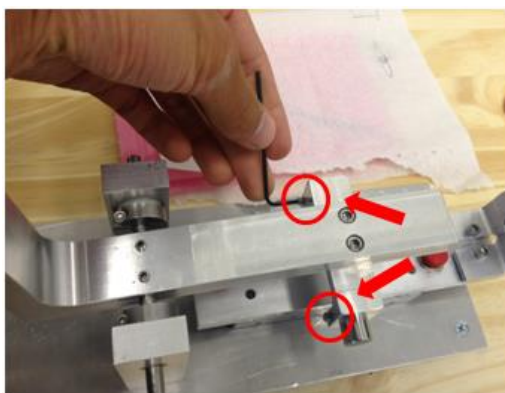

4. Wash the cylinder with water and scrub to remove any possible Teflon build-up from previous tests.
5. Replace contact cylinder and tighten set screws.
6. Turn the pressure regulator dial all the way to the left and connect the air hose to the compressed air supply. The air supply MUST have a pressure output between 30-80 psi.



7. Plug in the electric actuator into a standard 120V outlet.

Sample Preparation:

1. Cut wire samples to 5-6 inches in length using a wire cutter.
2. Strip approximately 0.5 inch of coating on one end of the wire using wire strippers.



7. Test Procedure

7.1 Mounting Sample

1. Fix the wire sample on the sliding plate by first inserting it through the hole of the "L" bracket. The stripped end of the wire should be on the side of the "L" bracket.

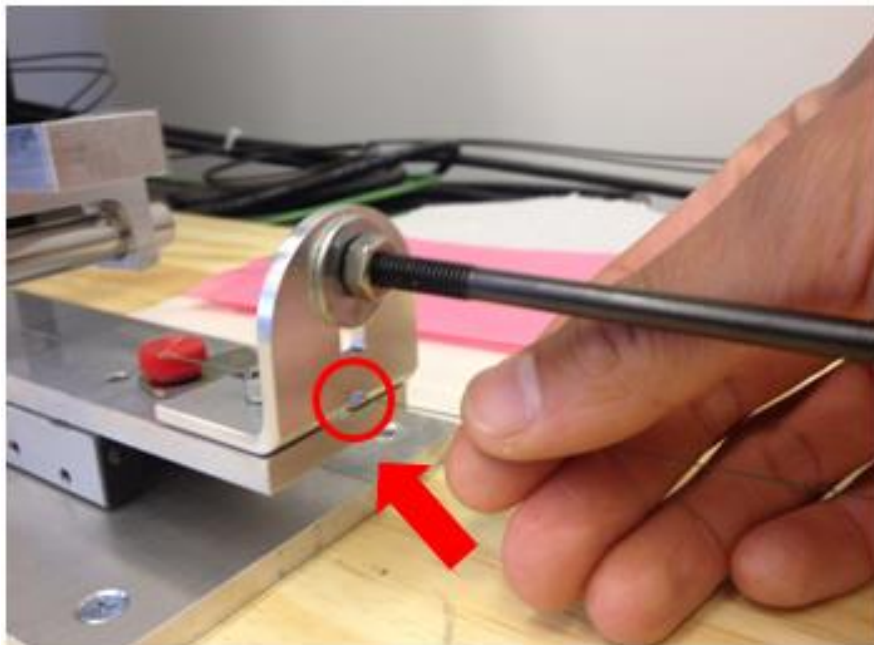

2. Direct the wire underneath the first holding plate and fasten the screw so that the stripped end of the wire is still on the outer edge.

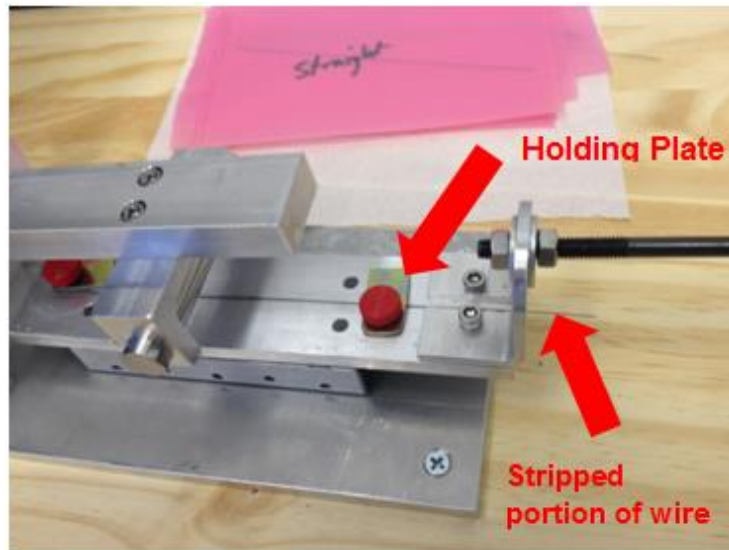

3. With one end of the wire fixed, slide the other end underneath the second holding plate. The wire should be resting in the center groove.

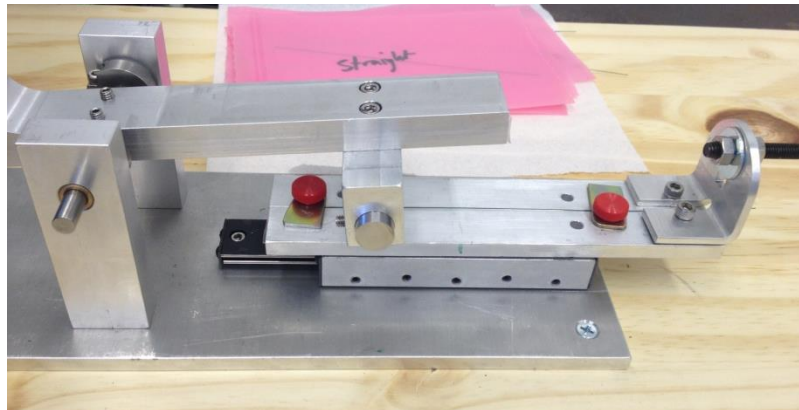

4. Remove slack in the wire by running your finger from end to end, and then fasten the second holding plate.

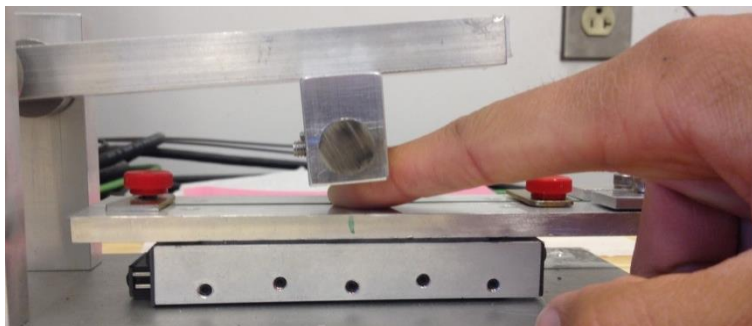

5. Attach one lead of the continuity tester to the back end of the set screw holding the contact cylinder. Connect the other lead to the stripped section of the wire sample.

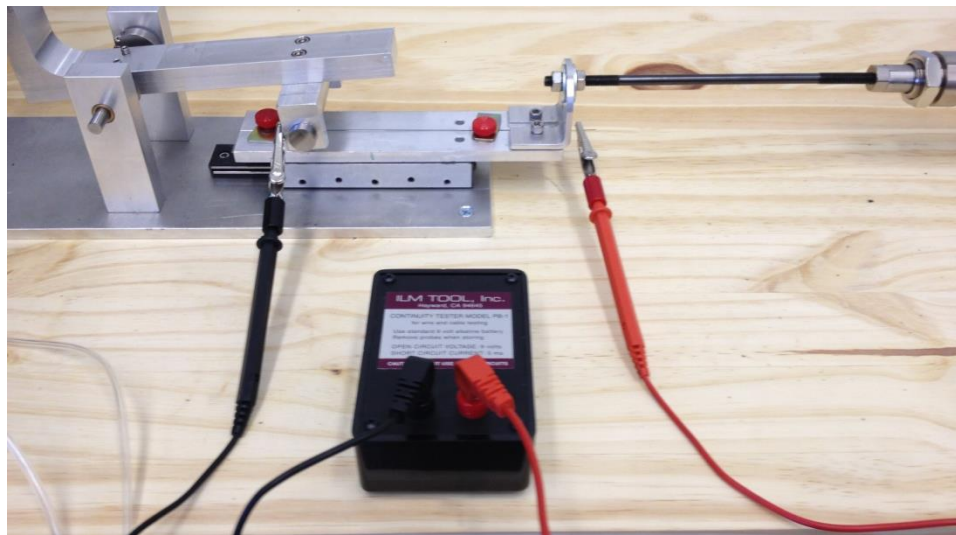
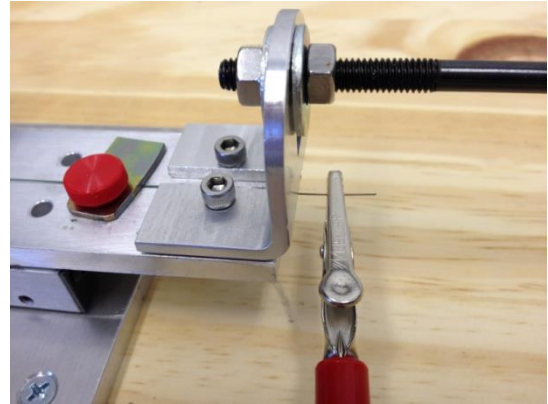
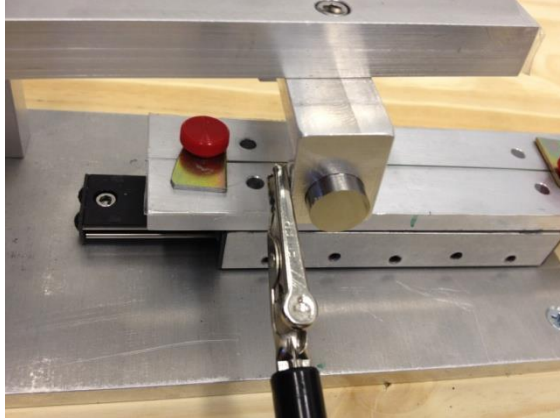

7.2 Running the Test

1. Position the slider so the contact cylinder is positioned directly above one end of the wire sample. Check the test set up to ensure the contact cylinder can reach both ends of the wire sample when lowered.

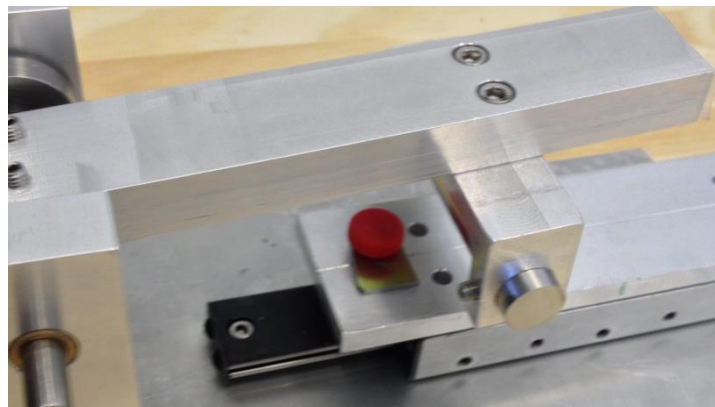

2. Set the pressure regulator to 3.0 psi and flip the pressure switch to lower the contact cylinder.

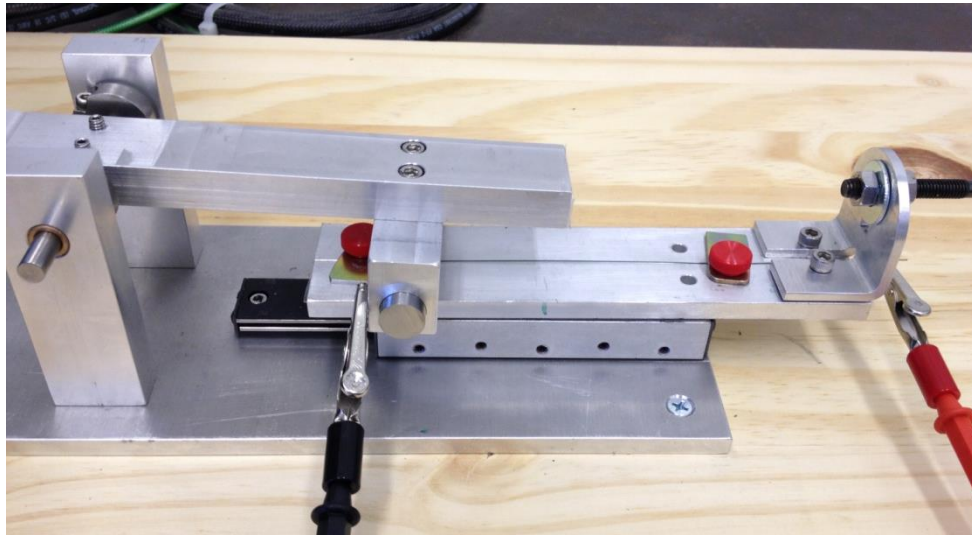

3. With the control box, actuate the slider so the cylinder is dragged to the other end of the wire sample. Press the on button to extend the actuator. To contract the actuator, hold the A-phase button then press the on button while still holding the A-phase button.

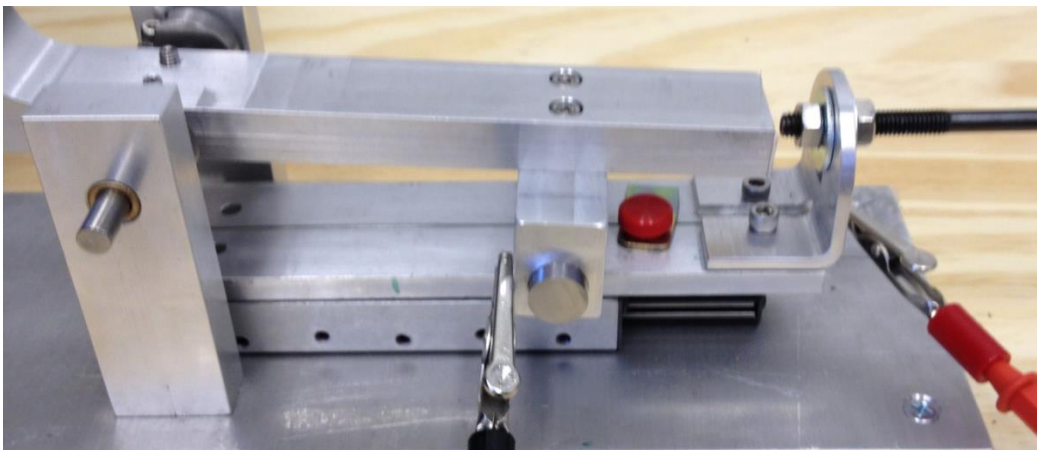



4. If no breach in the coating is detected, increase the pressure regulator up 0.5 psi. The pressure regulator should read 3.5 psi. Each additional tick mark on the regulator correlates to an increase in 0.5 psi.



5. Actuate the slider back so the contact cylinder is dragged back to the original starting position.

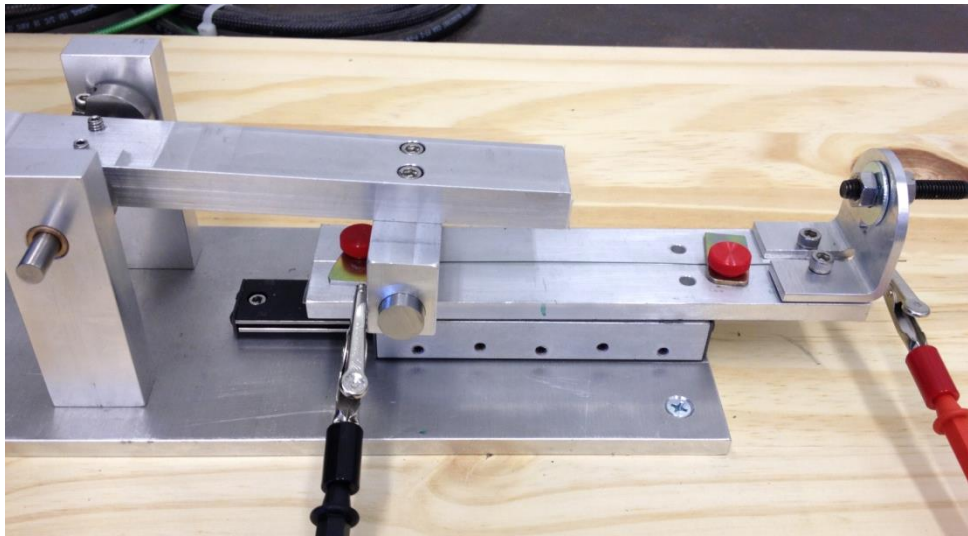

6. If no breach in the coating is detected, increase the pressure regulator another 0.5 psi. The pressure regulator should read 4.0 psi.



7. Actuate the slider so the cylinder is again dragged to the other end of the wire sample.
8. If no breach in the coating is detected, continue this process by incrementally increasing the pressure by 0.5 psi after each pass.
9. When a breach is detected, record the pressure value at which the coating was breached.
10. Lower the pressure regulator back by turning the dial all the way to the left and flip the pressure switch to raise the cylinder.
NOTE: The pressure should be lowered first before the switch is flipped so the pneumatic actuator is not damaged.

11. Unscrew the holding plates, unclip the continuity tester leads, and properly dispose of the wire sample.

8. Appendix*

None.