

# Design Improvement for the Smart DC Wall Plug

By

Cory Yee  
Haoyan Huang

Senior Project

ELECTRICAL ENGINEERING DEPARTMENT

California Polytechnic State University

San Luis Obispo

2014

**Table of Contents**

Abstract ..... v

Chapter 1: Introduction ..... 6

Chapter 2: Background ..... 8

Chapter 3: Requirements and Specifications..... 10

Chapter 4: Design..... 12

    Section A: Designing the DC SWaP Prototype ..... 12

    Section B: Component Calculations ..... 15

    Section C: DC SWaP Design Revisions ..... 18

    Section D: DC SWaP Extremities ..... 20

Chapter 5: Testing ..... 22

    Section A: Testing DC SWaP Prototype ..... 22

    Section B: DC SWaP Final Design Testing..... 24

Chapter 6: Conclusion and Recommendations..... 28

Reference ..... 29

APPENDIX A — ANALYSIS OF SENIOR PROJECT DESIGN ..... 30

APPENDIX B – TEST DATA..... 37

APPENDIX C – ARDUINO CODE ..... 39

    Code 1: Arduino Code for Wall Plug ..... 39

    Code 2: Arduino Code for Programming Tags ..... 42

## List of Figures

Figure 4-1: Block Diagram for Design V1.0 [2] .....	12
Figure 4-2: DC SWaP Block Diagram .....	13
Figure 4-3: LTSpice model of the LTC3891 Buck Controller.....	14
Figure 4-4: LTC3891 simulation results (48V input, 5V@10A output. Top Plot: Upper (red) and lower (cyan) MOSFET Gate voltage. Bottom Plot: Inductor current (blue) and output voltage (green).....	14
Figure 4-5: LTC3891 simulation results (48V input, 24V@10A output. Top Plot: Upper (red) and lower (cyan) MOSFET Gate voltage. Bottom Plot: Inductor current (blue) and output voltage (green).....	15
Figure 4-6: Setting Output Voltage of the LTC3891 [6] .....	16
Figure 4-7 - Prototype PCB Layout.....	18
Figure 4-8: Design Prototype .....	18
Figure 4-9 - Buck Converter for Arduino.....	19
Figure 4-10: Final PCB layout (left) and PCB Board with all Components (Right).....	19
Figure 4-11: Cross Section of the Wall Plug .....	20
Figure 4-12: Custom Plug for DC SWaP.....	21
Figure 4-13: Finished DC SWaP .....	21
Figure 5-1: Buck Tested at 5V and 1A output .....	22
Figure 5-2: Testing of a 12V DC Fan .....	23
Figure 5-3: Prototype Synchronous Switch Ripple.....	23
Figure 5-4: DC SWaP Power Efficiency.....	24
Figure 5-5 - Synchronous Switch Capture with Snubber .....	25
Figure 5-6 - DC SWaP Powering a TV .....	27

# List of Tables

Table 3-1: 2nd Generation Smart DC Wall Plug Requirements and Specifications ..... 10

Table 5-1: Power Rating and Short Circuit Test Data..... 26

Table A-1 - Types of Economic Capitals and Their Impacts Relative to the Smart DC Wall Plug..... 31

Table A-2 - Manufacturing Estimates ..... 32

Table C-1 – Power Efficiency Data with  $V_{out} = 5V$  ..... 37

Table C-2– Power Efficiency Data with  $V_{out} = 9V$  ..... 37

Table C-3 – Power Efficiency Data with  $V_{out} = 12V$  ..... 37

Table C-4 – Power Efficiency Data with  $V_{out} = 15V$  ..... 38

Table C-5 – Power Efficiency Data with  $V_{out} = 24V$  ..... 38

Table C-6 – Line Regulation Data with  $V_{OUT,LOW} = 38V$ ,  $V_{OUT,HIGH} = 58V$ , and  $I_{OUT} = 3A$ ..... 38

## Abstract

The DC smart wall plug is a subsystem within the Cal Poly DC House Project. The previous version faces challenges supplying DC voltage to meet household appliances' nominal values. Specifically, it can only output the minimum required voltage for DC appliances to operate, resulting in unwanted power loss. In addition, the maximum output voltage is rated at 15V, which is insufficient to power most DC appliances. This design improvement project incorporates NFC technology as a solution to overcome the power loss and a new buck converter configuration to increase the output voltage range. Additionally, the new design introduces short-circuit and reverse polarity protection. Packaging the DC wall plug within an enclosure brings the final design to a production-ready stage. Eventually, the smart plug will reside in a DC House.

## Chapter 1: Introduction

In today's technologically advanced society, electricity is available to most countries around the world. However, not the entire world is fortunate enough to enjoy a leisure life simplified with electricity. The single thought of helping improve the lives of people around the world who live without electricity, by providing them access to electricity, gave birth to a single great idea: the DC house. The DC house project, initiated at Cal Poly San Luis Obispo in 2010, is a completely modular and self-dependent power supply system that is able to provide convenient means of electricity to small cities and villages not located on any electrical grid. The DC House features a scalable system, so people can purchase the right amount of power according to their need. For example, if a family only needs a 10W light bulb, all they need to buy is the light bulb and the components that meet the 10W requirement; if they want more power, an option to attach additional components is available. The goal of the DC house is to provide sustainable and low cost electricity for the less fortunate areas without the need for large scale infrastructure.

As the name implies, a DC house operates solely on DC power since most renewable energy sources at low power levels generate DC power. As a result, all of the design phases also incorporate the designing of DC power generators based on sustainable sources such as hydroelectricity, solar power, wind power as well as human power. Having a DC House setup in areas where utility grids are out of reach is more efficient as the power comes from the previously stated renewable energy sources [1]. This eliminates the need to convert from DC power to AC and then back to DC. The power generated will then be stored within large batteries to be later distributed among several DC houses, and then finally into various household appliances.

The DC smart wall plug acts as a subsystem in the DC house project that transforms 48V, from the main power line of the DC house, to various lower voltages required by different household appliances. The previous design outputs sufficient voltage, easily at the minimum voltage level, to

operate some DC appliances; however, improvements are needed to acquire better operation and accuracy [2]. One drawback is that the minimum operational voltage that the wall plug provides usually results in unwanted power losses. The proposed design revision described in this report incorporates NFC technology to automatically detect and output the required voltage rating of the load, thus the title “smart”. Overall, the DC smart wall plug is a variable buck converter that automatically supplies power to various DC loads at relatively high efficiencies. The ultimate goal of this project is to provide an effortless experience on using DC wall plug in a DC House as anyone would with AC wall plug in a traditional house.

## Chapter 2: Background

A quarter of humanity, 1.6 billion people, live their everyday lives without electricity. Of the 1.6 billion, a total of approximately 930 million (58%) live in South or East Asia, and approximately 547 million (34%) live in Sub-Saharan Africa [3]. This is primarily due to the juxtaposition of poverty and geographical challenges present in the country that make implementing a power grid nearly impossible. This brings us to Dr. Taufik's solution: the DC House Project. It is a humanitarian project to design a cheap, sustainable house that will be built in locations off the utility grid [1]. As the name implies, the house operates solely on DC power. This power originates from renewable energy sources such as solar, hydro-electric, or even human-powered. These generators output DC power, thus can be used to directly power the DC house, eliminating the need to convert DC power to AC. The elimination of the conversion step benefits the system greatly, as DC to AC conversion would require additional parts, increasing cost, and would decrease power efficiency due to conversion losses. Moreover, using a DC-DC distribution system reduces heat generation by 1.5% and decreases the overall size of power supplies by 20% [4]. Overall, the purpose of the DC house is to provide electricity to the quarter of humanity who live without it by giving them an affordable mean to convert the natural energy around them into electrical energy.

To deliver power into appliances from the main 48V power line, a DC wall plug has been designed. The initial design of the wall plug during phase 1 of the DC house required manual selection of four fixed output voltages through a selector pin ( $R_{\text{select}}$ ) inside the plug receptacle [5]. This was found to be too inflexible of a system and thus a smart DC wall plug was designed in phase 2. The advantage of incorporating a smart DC wall plug was that it could automatically detect what output parameters are necessary to power a specific DC appliance, which would ideally maximize power efficiency. The method used was to step up output voltage in 0.5V intervals until a load was detected [2]. However, due to the non-idealities of electrical appliances, this method achieved only the minimum turn-on voltages for the



appliances rather than the nominal (optimal) voltage. This results in excess load, decreasing the efficiency of the power delivered to the load. Other shortcomings of the previous design include a lack of any type of electrical protection and a small voltage range of 5V -15V.

As an improvement of the original Smart DC wall plug concept from previous work, a new name is given to differentiate the two: the DC SWaP (Smart Wall Plug). The improved design overcomes the shortcomings of the previous concept. The SWaP is not only capable of reaching appliances demanded voltage, but also handles enough power to operate large DC loads (TV, refrigerator, etc.). To ensure the SWaP automatically outputs the correct voltage accurately, communication is established between the load and supply. Instead of continuously monitoring the current condition, which keeps the microprocessor busy, it is easier to let the load set the desired voltage. In turn, the wall plug will supply the same voltage until the load disconnects. As a precaution, safety features are added to the system to shut down the wall plug under unsafe conditions. To achieve this goal, a passive “tag” is attached to the DC load and the SWaP reads the tag to determine the output. Several methods were up for debate when designing the SWaP, include RFID, Bar Code, and color code. The final decision was made between the RFID and NFC (similar to RFID but operates at higher frequency and shorter distance). Finally, the NFC approach seems to be more suitable than the RFID due to the short operating distance and large amount of data storage space in NFC tag, which gives more room for future improvements of the project. The main concern for using NFC is its price; the added NFC reader adds more cost of the wall plug. However, since the NFC is a relatively new technology, with increased popularity, the price will drop in the near future.

## Chapter 3: Requirements and Specifications

The purpose of the Smart DC Wall plug is to provide an easy-to-use and efficient power source for various loads inside the DC house without manually changing the output voltage. Customer needs dictates that the Smart DC Wall plug shall power at least two various household items with voltage ratings between 5V to 24V, such as clocks and radios, at maximum efficiency. Moreover, it shall include short circuit, overvoltage, and reverse polarity protection for the customers' protection as well as increased product lifespan [3]. Other considerations taken into account include the maximum power output of the wall plug shall not exceed 50 watts and the output voltage is within 5% difference of the load nominal input voltage. For customer convenience, the outlet must have a clear distinction that only DC appliances in a certain orientation may be used.

Safety is a major concern when it comes to DC power systems. Unlike the normalized AC power systems, being shocked by DC power systems is more fatal since the power flow is continuous; AC power oscillates and returns to zero. Moreover, DC current tends to just make the heart stand still [5]. This characteristic juxtaposed with the previously stated continuous behavior of DC current can simulate a heart attack, possibly leading to death.

**Table 3-1: 2nd Generation Smart DC Wall Plug Requirements and Specifications**

Marketing Requirements	Engineering Specifications	Justification
4, 8	1. Achieve $\pm 5\%$ nominal DC load voltage	Electronic devices have the best performance and efficiency when operating at rated voltage.
1, 2, 5	2. All components should fit into a multi-layer 4" by 4" PCB board.	4" by 4" is the typical size for wall plug box.
3	3. Should include short circuit protection or overcurrent protection	Adding current surge protection will increase overall sustainability
3	4. The system should include reverse polarity protection	Plugging in an appliance with the wrong polarity can damage it. This error is easy to do since the wall plug's physical design is two-pronged
2	5. The overall product shall consume little or no power, unless it is delivering power	The microprocessor is constantly consuming power even without a load

7	6. The DC SWaP and AC loads shall not be compatible with each other	This reduces the chance of using AC loads on the DC wall plug
2, 8	7. Should have an output peak power of 100W	This maximum power output provides more than adequate power for most small electrical household appliances. The upper limit is set as to not oversupply current to the devices.
8	8. The system should have an output voltage range of 5-24V	To accommodate more appliances, a larger voltage range is needed.
	9. The voltage step-down process should have a minimum of 80% power efficiency	Every watt of power is important in small power systems, so high power efficiency is desired to optimize power usage.
2,3,6,8	10. The load and line regulation of the system shall be below 2%	Low percentages are required so the output voltages stays near constant value.

**Marketing Requirements**

1. Reduce package size.
2. Increase efficiency.
3. System should include the same safety features as other commercially available DC power supply offered.
4. System should detect and output the rated input voltage for any DC load.
5. Final product does not require user configuration after installation.
6. Final product should mimic the functionality of AC wall plug.
7. Customers can tell the difference between the DC wall plug and AC wall plug.
8. The system should be able to accommodate daily household electrical appliances

The requirements and specifications table format derives from [7], Chapter 3.

# Chapter 4: Design

## Section A: Designing the DC SWaP Prototype

The previous design proved the concept of a self-adjustable output voltage DC transformer. However, the design was not without flaws, which brings us to the intention of this project: to design and fabricate a “smarter” DC wall plug.

Figure 4-1 shows an overall block diagram from the previous design (V1.0). It takes 48V DC input and outputs 5 to 15V to the load. The output voltage is set upon detection of a load. A microprocessor is used to sample the output current. If there is no current, then the microcontroller steps up the buck converter’s output voltage through a digital potentiometer until the load current is stable. According to the previous design’s test results, this design has no problem reaching an appliance’s minimum operating voltage. However, it is not capable of supplying an appliance’s nominally rated voltage.

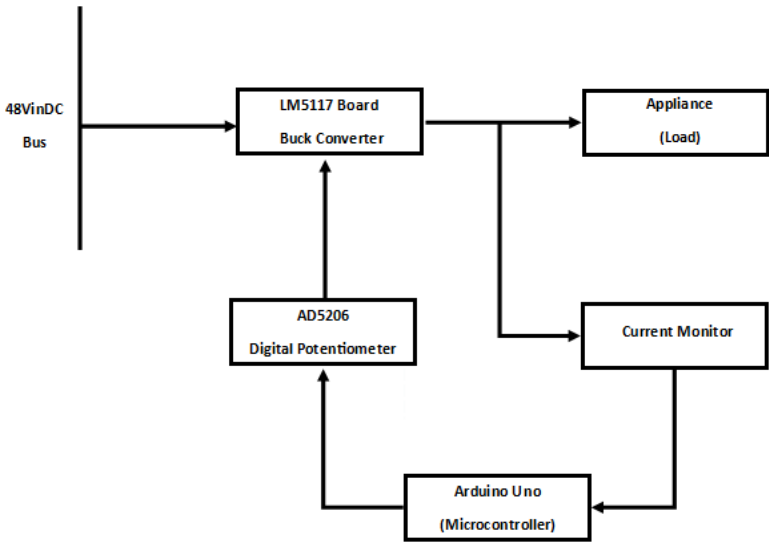
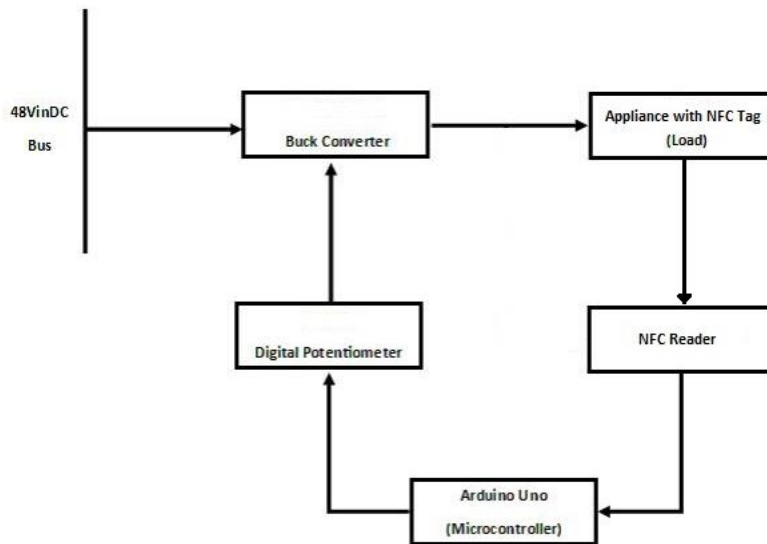


Figure 4-1: Block Diagram for Design V1.0 [2]

In order to fix this flaw and increase the accuracy of the output voltage, an upgrade (V2.0) of the wall plug was necessary. The second version, later renamed to the DC SWaP, lets the appliance set the output voltage directly with additional sensors. Numerous technologies were considered for the

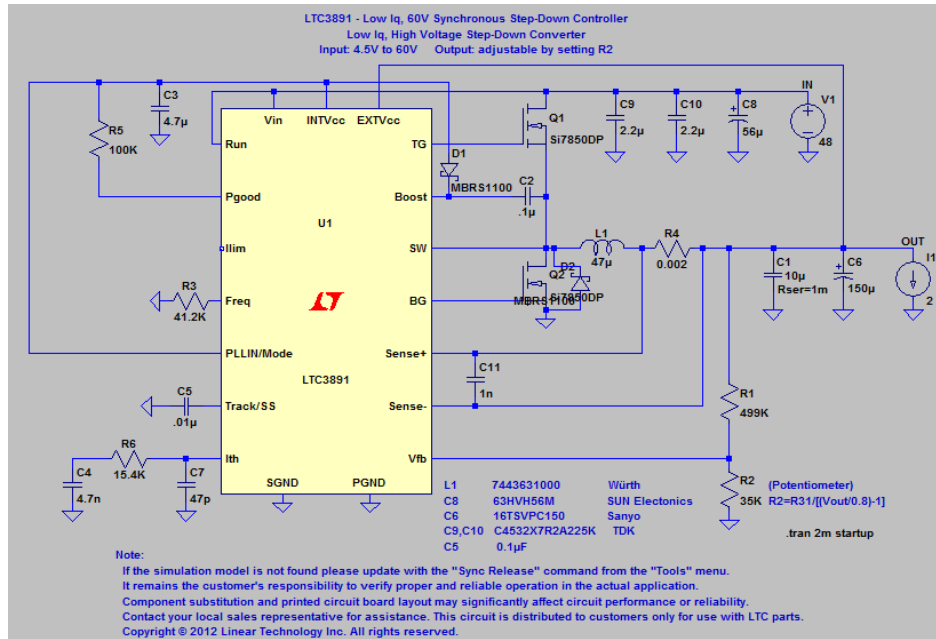
implementation including RFID, barcode reader, and color detection. Due to the nature of the outlet, it was determined that NFC (Near Field Communication, a variant of RFID) is the best option due to their short operating distance ( $\leq 3''$ ) and compact size.. In this new approach shown in **Figure 4-2**, the appliance will carry a NFC tag to communicate with the NFC reader in the wall plug. The NFC reader transfers the appliance's information to the Arduino which then sets the output voltage of the buck converter. The Buck converter only turns on when a NFC tag is detected.



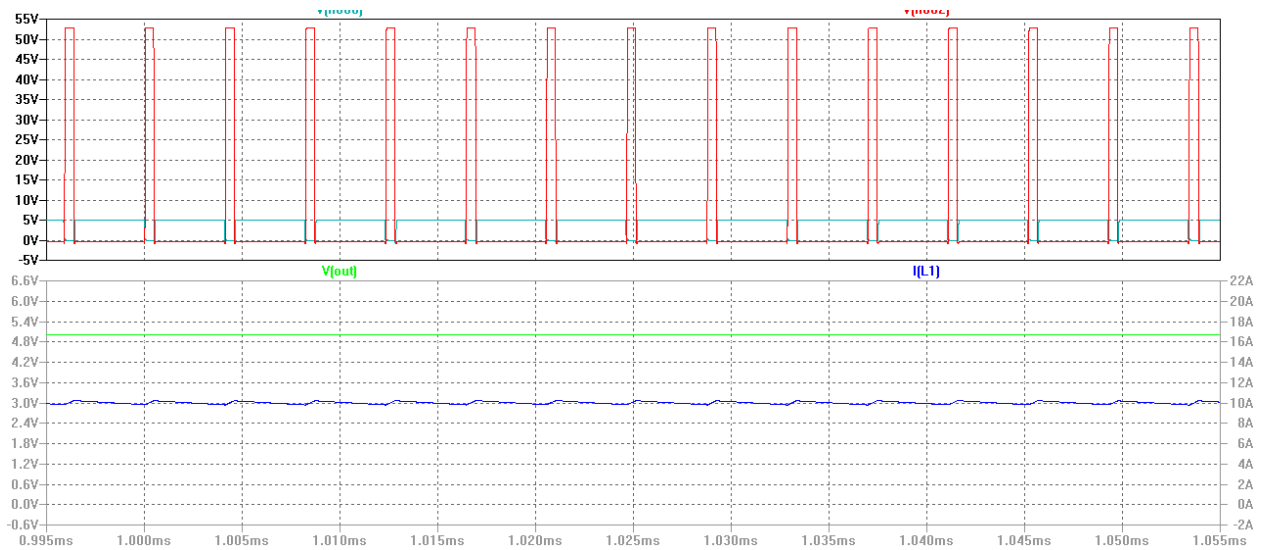
**Figure 4-2: DC SWaP Block Diagram**

In V1.0, the buck converter (LM5117 Evaluation Board) is designed and built by Texas Instruments. It gives very limited flexibility for adjusting output voltage and power capability. As the power requirements of the appliances used with the DC SWaP vary greatly from one another, a different buck converter is needed to improve design freedom and accommodate for the various output demands. The new controller selected, the LTC3891 buck controller, can handle a much larger output voltage and output power range. Moreover, it contains overvoltage protection and over current protection. The overvoltage protection kicks in when the feedback pin rises by more than 10% above its regulation point of 0.8V and shuts off the top MOSFET (Q1 in **Figure 4-3**) and turns on the bottom MOSFET (Q2 in **Figure 4-3**) until the over voltage condition is cleared [6]. As for over current protection,

the controller has an  $I_{LIM}$  pin which limits the maximum allowed current through the output of the buck. Simulation results of the circuit can be seen in **Figures 4-4** and **4-5** below.

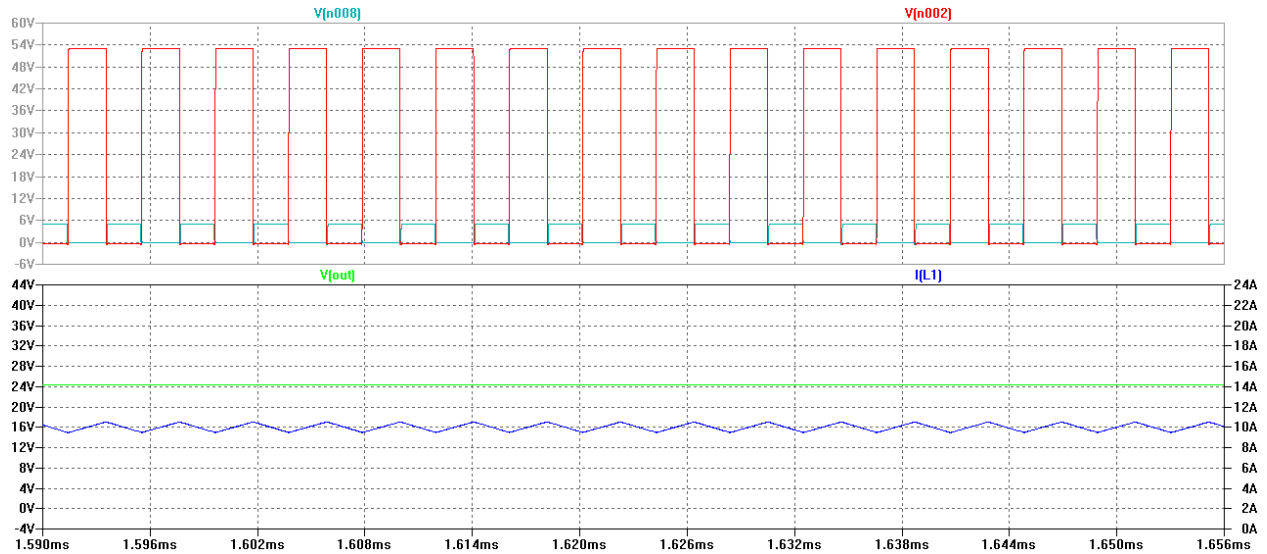


**Figure 4-3: LTSpice model of the LTC3891 Buck Controller**



**Figure 4-4: LTC3891 simulation results (48V input, 5V@10A output. Top Plot: Upper (red) and lower (cyan) MOSFET Gate voltage. Bottom Plot: Inductor current (blue) and output voltage (green)**

The simulation shown in **Figure 4-4** above shows a steady 5V output and 10A load with a minimized inductor current ripple. This proves that this buck converter is able to operate at high relatively high loads and still be able to deliver a minimum of 50W.

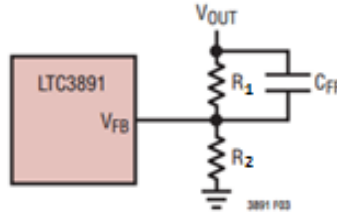


**Figure 4-5: LTC3891 simulation results (48V input, 24V@10A output. Top Plot: Upper (red) and lower (cyan) MOSFET Gate voltage. Bottom Plot: Inductor current (blue) and output voltage (green).**

The simulation shown in **Figure 4-5** above shows an output slightly above 24V with a load of 10A. Although this proves that the buck is able to output 240W of power, it is unadvised as it creates a larger inductor current ripple.

## Section B: Component Calculations

The first step in designing a buck is setting the output voltage. The LTC3891 chip sets its output voltage by an external feedback resistor divider placed across the output as shown in **Figure 4-6** below. To improve frequency response, great care should be taken to route the  $V_{FB}$  line away from noise sources such as the inductor or the SW line.



**Figure 4-6: Setting Output Voltage of the LTC3891 [6]**

For  $R_1$ , a 487k $\Omega$  resistor was chosen. Thus, a 100k $\Omega$  digital potentiometer with 256 steps fulfills the role of  $R_2$ . The following equations are thus derived from LTC 3891 datasheet [6] to determine how to set the digital potentiometer. Calculations for the output voltage of the buck converter begins with the equation below.

$$V_{OUT} = 0.8 \left( 1 + \frac{R_1}{R_2} \right) = 0.8 \left( 1 + \frac{487k}{R_2} \right)$$

To solve for the required  $R_2$  value, rearrange the equation:

$$R_2 = \frac{487k}{\frac{V_{OUT}}{0.8} - 1}$$

Next, represent the resistance of the digital potentiometer based on its characteristics. The step level represents the 8-bit digital potentiometer's wiper position ranging from 0 to 255.

$$R_2 = \frac{\text{Actual Total Resistance} * \text{Step Level}}{\text{Total \# of steps}} = \frac{94.5k}{256} (\text{Step Level})$$

Combining the previous 2 equations yields:

$$\text{Step Level} = \frac{487k(256)}{94.5k \left( \frac{V_{OUT}}{0.8} - 1 \right)}$$

Rearranging the inductor ripple current equation provided and using the maximum output voltage, we can calculate the critical inductance. To complete the calculation, switching frequency must be known: resistor  $R_3$  has been selected as to set the controller's operational frequency to 166 kHz. This is a relatively low frequency for a switching converter, running at low frequency helps to reduce switching



noise and makes debugging easier when failure occurs. To calculate the maximum critical inductance, the maximum output voltage (24V) is used, and most 24V household appliances (refrigerator, motor, etc.) typically have a minimum operation point larger than 1A, therefore a maximum of 2A inductor current ripple can be allowed to maintain continuous conduction mode (CCM).

$$L = \frac{1}{(f)\Delta I_L} V_{OUT} \left(1 - \frac{V_{OUT}}{V_{IN}}\right) = \frac{1}{(166kHz)(2A)} (24V) \left(1 - \frac{24V}{48V}\right) = 36\mu H [7]$$

In designing switching converters, an inductor with higher inductance than the critical inductance is preferred; a 47 $\mu$ H inductor was chosen. With the selected inductor, the next step is to calculate the output capacitance.

$$C_O = \frac{1-D}{\Delta V * L * f^2} [7]$$

The minimum capacitance needed to filter the output to have a 1% ripple can be calculated by finding when the duty cycle is at its lowest. In this case, it is when the output voltage is 5V.

$$D = \frac{V_{OUT}}{V_{IN}} = \frac{5V}{48V} [7]$$

With that, all the variables required to solve for the output capacitance are present.

$$C_O = \frac{1 - \frac{5}{48}}{(.01) * (47 * 10^{-6}) * (166 * 10^3)^2} = 69.17\mu F$$

However, through personal experience, more capacitance in parallel is required to reduce the output ripple as well as Equivalent series resistance (ESR). Thus, a 150 $\mu$ F output capacitor, as seen in the simulations provided, meets the requirements. With all the buck components calculated for, it was decided to design a PCB. Using a PCB benefits us as it involves less human error in assembling the buck and allows the use of surface mount components, which achieves our design requirement of keeping the buck small. Express PCB is the software used to design the PCB as it is user friendly and the production cost is at a reasonable price. The PCB layout can be seen in **Figure 4-7** below and the overall design can be seen in **Figure 4-8** below.

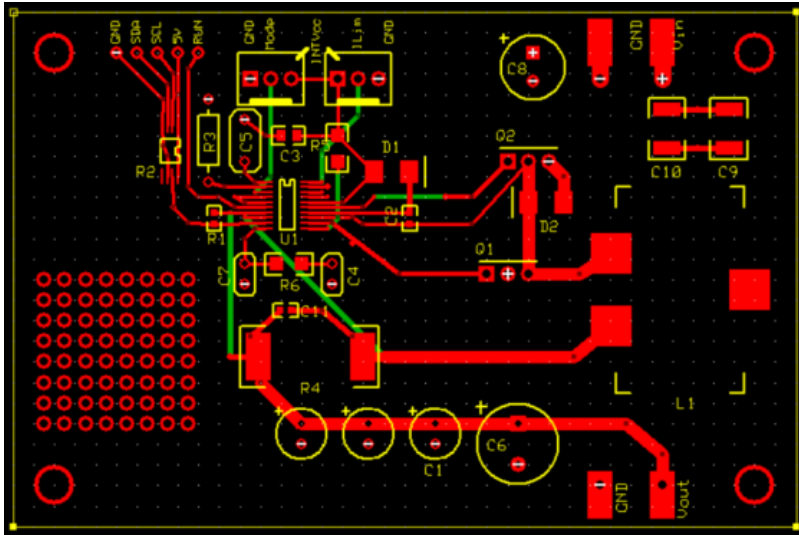


Figure 4-7 - Prototype PCB Layout

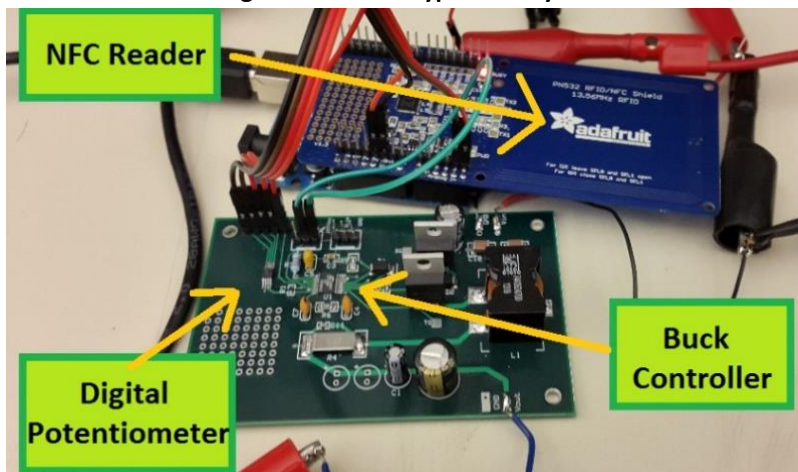
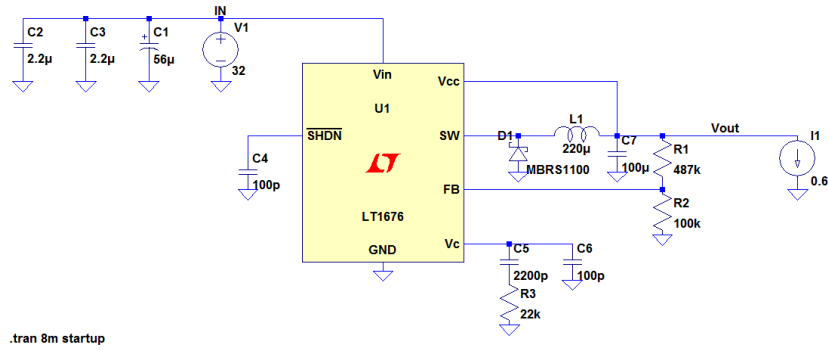


Figure 4-8: Design Prototype

### Section C: DC SWaP Design Revisions

After testing the prototype, we discovered several flaws with the design. First of all, some traces on the PCB, namely the output trace, were too thin to physically operate under high load conditions. Moreover, the via-hole field was initially planned for a prepackaged buck converter to power the Arduino, but they were out of budget and out of stock. Thus, we replaced the via-hole field on the PCB with a secondary buck converter using the LT1676 chip [8] as seen in **Figure 4-9** below. The output of the secondary is set to 7.3V to send power to both the Arduino (7V minimum required input) and the EXT<sub>Vcc</sub> of LTC3891 (8V Maximum for bypassing internal regulator to increase efficiency [9]).



.tran 8m startup

Figure 4-9 - Buck Converter for Arduino

The third flaw found with the DC SWaP prototype was that at higher loads, there was a distinct, audible buzz coming from the inductor. This does not necessarily mean poor performance, but it does arouse concern. This problem was solved by changing to a different MOSFET. We theorized the problem came from the resonance caused by the  $R_{DS(on)}$  and parasitic capacitance of the MOSFET, and by switching to one with lower values, the resonance point was shifted.

Another flaw found was the amount of noise generated from the synchronous switch, so we implemented an RC snubber circuit. The final change was to add a heat sink to the main switch of the main buck converter to increase thermal dissipation as the MOSFET would get noticeably hot operating under higher loads. The final PCB layout and the board can be seen in **Figure 4-10** below.

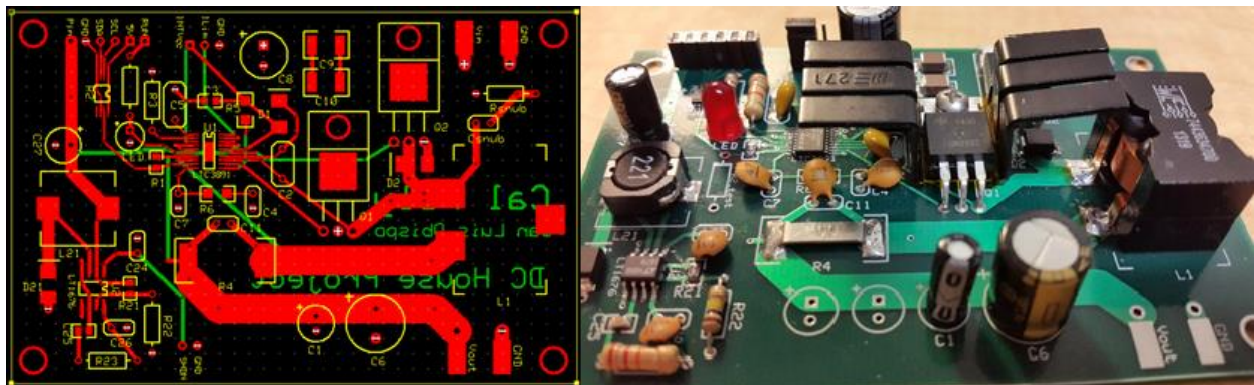
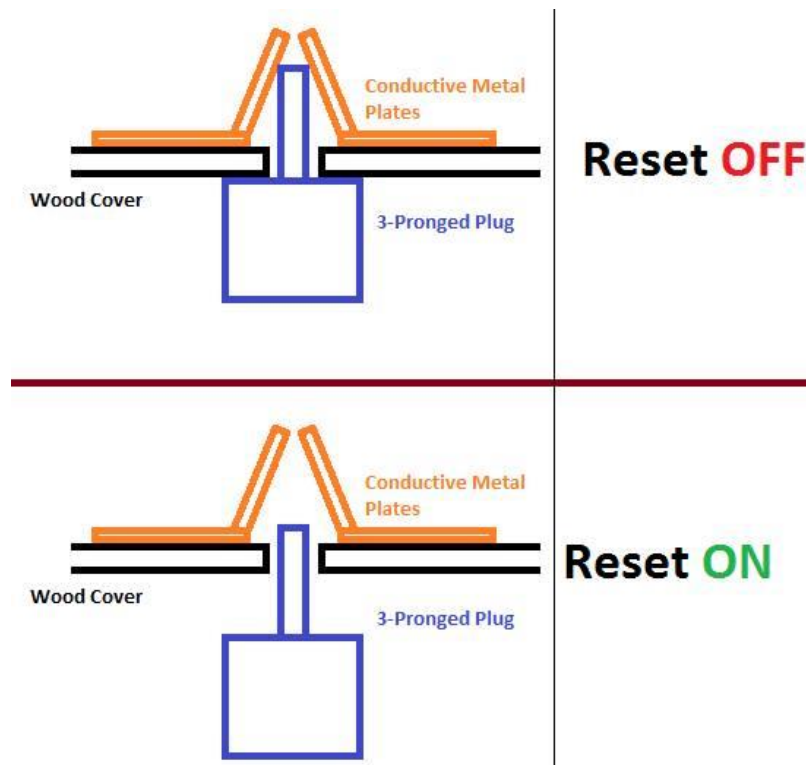


Figure 4-10: Final PCB layout (left) and PCB Board with all Components (Right)

## Section D: DC SWaP Extremities

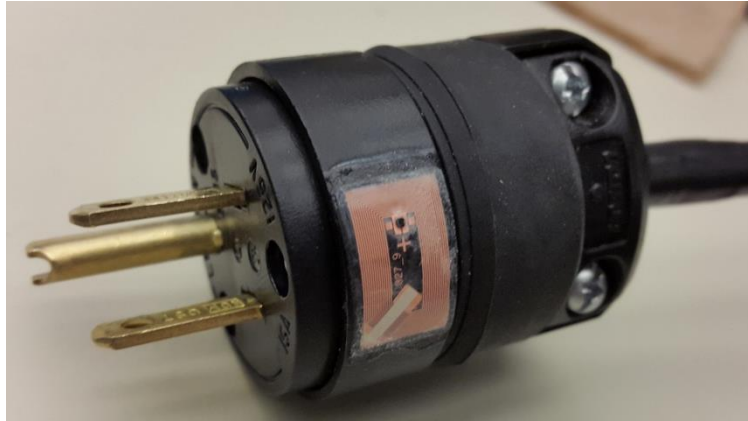
To package our DC SWaP, a blue electrical box has enough space to contain all the electronics. A mechanical set up was devised to control the reset pin of the Arduino. It involves using a two pronged outlet and a three-pronged plug. A hole was drilled into the wooden cover where the third prong is supposed to go, and on the other side of the hole, two metal plates were placed. How it works is that when the plug is put in, it shorts the two plates together and when the plug is disconnected, it triggers the reset pin of the Arduino, allowing a signal to turn off the buck converter by switching the RUN pin of LTC3891 to low (0V). **Figure 4-11** below shows how the mechanical system works. A switch connecting the main power line and the PCB for manual shut off of the whole system was also included for safe measure.



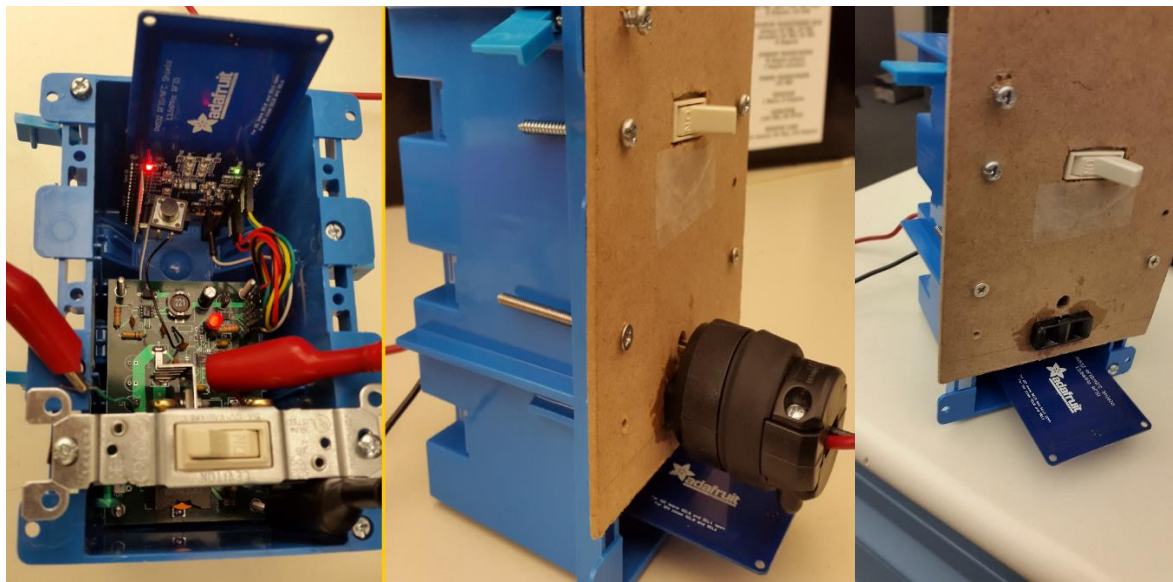
**Figure 4-11: Cross Section of the Wall Plug**

To test our appliances, we removed any AC/DC transformer and outfitted them with our own plugs. Each plug is polarized and prevents the load from being connected in reverse polarity. On each

plug, we programmed the RFID tags to contain the voltage levels according to the ratings of the appliance that they will tag. An example of the custom plug can be seen in **Figure 4-12** below. Figure 4-13 shows the finished product.



**Figure 4-12: Custom Plug for DC SWaP**



**Figure 4-13: Finished DC SWaP**

# Chapter 5: Testing

## Section A: Testing DC SWaP Prototype

To test our design, we used the MPJA DC regulated power supply and the BK Precision 150W DC Electronic Load. Testing the buck with an output voltage of 16V resulted in frying the controller. This was determined to be due to the ExtVcc pin having different settings for different load ratings. As a result, testing the buck began with output settings of 5V at 1A.

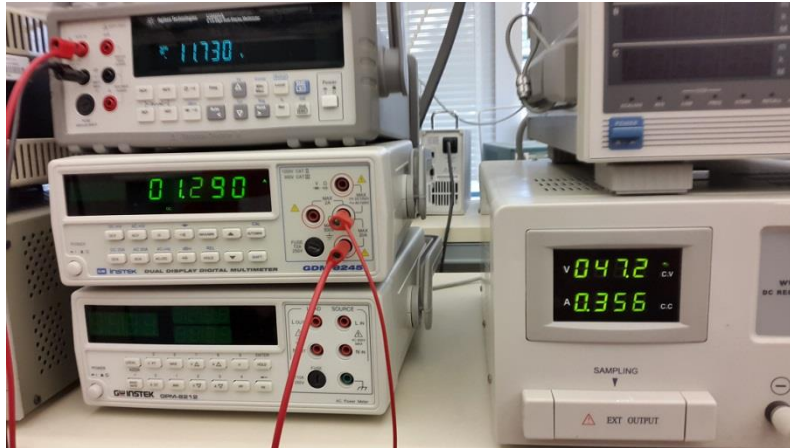


Figure 5-1: Buck Tested at 5V and 1A output

From Figure 5-1, the power efficiency can be determined using the equation below.

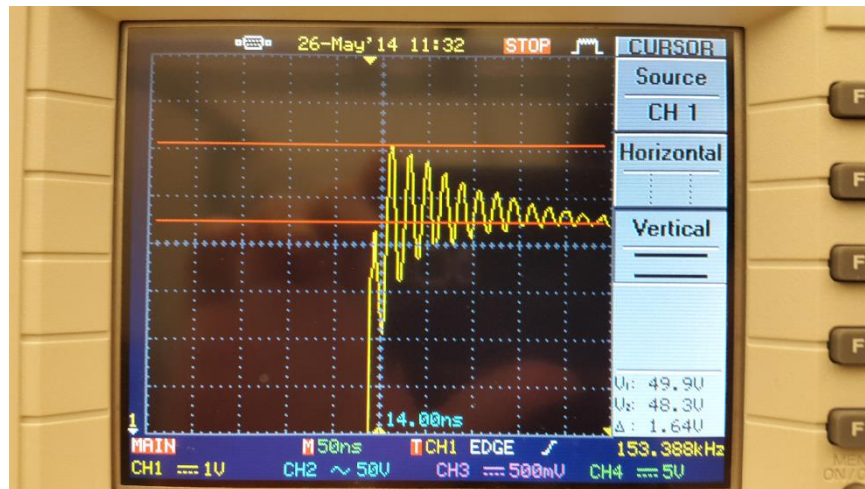
$$\eta = \frac{V_{OUT}I_{OUT}}{V_{IN}I_{IN}} \times 100 = \frac{4.445V * .999A}{48V * .121A} \times 100 = 76.46\%$$

This output efficiency calculated here is expected as buck converters are less efficient at lower output voltages. When testing a DC fan rated at 12V and 1.5A, power efficiency within our desired range is obtained. Figure 5-2 below shows a power efficiency of 90.5%



**Figure 5-2: Testing of a 12V DC Fan**

Checking the output voltage of the buck with output settings of 12V and 2A yielded a fairly noisy signal. Taking a look at the switching signal, a large overshoot and ripple is observed. **Figure 5-3** shows a 1.64V overshoot and an under-damped curve. To correct this, a RC snubber is required.



**Figure 5-3: Prototype Synchronous Switch Ripple**

RC snubber calculation [10]:

It is important to measure the effective capacitance, effective inductance and ringing frequency at the SW node of the buck converter to solve the resistor and capacitor needed for the RC snubber.

The ringing frequency measured at the switch node  $F_{ring} = 52\text{MHz}$

Effective capacitance is 1/3 of the external capacitor needed between SW and GND to reduce  $F_{ring}$  by half.  $C_{eff}$  is measured to be 300pF.

$$\text{Effective inductance } L_{eff} = \frac{1}{(C_{eff} * (2\pi F_{ring})^2)} = 28.4\text{nH}$$

Capacitor required for the snubber:

$$C_{snub} \geq 5 C_{effective} = 1.5\text{nF}$$

Resistor required for the snubber:

$$R_{snub} = \frac{1}{2} \sqrt{\frac{L_{eff}}{C_{eff}}} = 4.7\Omega$$

### Section B: DC SWaP Final Design Testing

Appendix C contains the data extracted from the equipment within the power electronics laboratory. The following figures were derived from the data collected.

The first test performed on the final product was the power efficiency test. This test used the same set up as mentioned in the previous section. Output levels of 5V, 9V, 12V, 15V, and 24V were tested at loads rated from 0.5A to 4A in intervals of 0.5A. Plotting the data yields the graphs below.

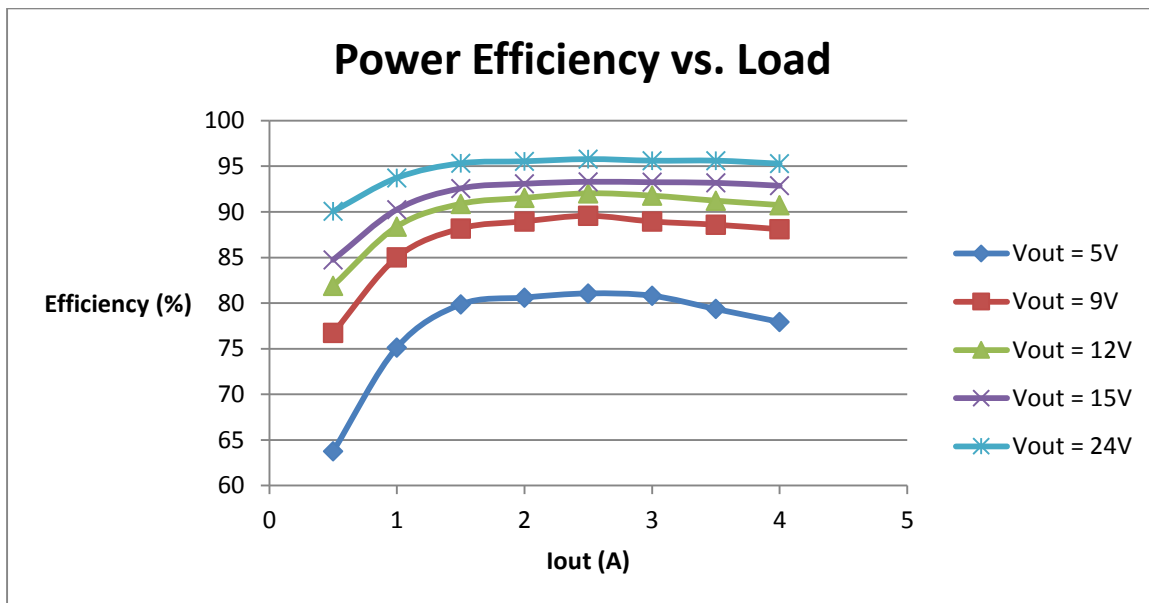


Figure 5-4: DC SWaP Power Efficiency



From the graph seen in **Figure 5-4** above, the majority of the various output settings operates within the 80% power efficiency requirement stated in chapter 3 above. Only the average power efficiency of the 5V output lies below the 80% mark, sitting at 77.315% power efficiency. All other averages are above 85%, and the highest average is 94.6% when the output voltage is at 24V. The trends of the graph tell us that power efficiency increases with output voltage, and that at a load of approximately 2.5A, the DC SWaP reaches its peak efficiency.

To test line regulation, output voltages of 5V, 9V, 12V, 15V and 24V were tested at a load of 3A. The input voltages used to test were 38V and 58V (48V nominal  $\pm 10V$ ). The following equation was used to calculate the amount of line regulation. The data in the appendix show that the system has very little line regulation with a maximum of only 0.2%. This achieves the goal set in Chapter 3 of having less than 2% line regulation.

The next test is to revisit the synchronous switch to observe its switching behavior. With the added snubber circuit, the overshoot decreased and the ripple is noticeably reduced. The resulting waveform can be seen in **Figure 5-5** below.



**Figure 5-5 - Synchronous Switch Capture with Snubber**

A final test on the overcurrent protection within the buck controller ensures the safety features of the controller are operational. During this test, the power rating of the DC SWaP is also measured. To do this, the output voltage is kept constant while the load is increased until the output voltage becomes noisy because noise generates a significant amount of heat in the main switch. In this case, the current at which the output voltage starts to get noisy is called the critical current. A 20% safety margin is allowed and then the values are used to calculate the power rating, as seen in the equation below. The load is then further increased until the controller shuts off; the current at which this happens is called  $I_{MAX}$ . This test is repeated for output voltages of 5V, 9V, 12V, 15V, and 24V. A test is performed for different  $I_{LIM}$  configurations:  $I_{LIM}$  connected to GND,  $I_{LIM}$  connected to INTV<sub>CC</sub>, and  $I_{LIM}$  floating. However, the test for  $I_{MAX}$  was not performed for  $I_{LIM}$  connected to INTV<sub>CC</sub> and  $I_{LIM}$  floating because the short circuit protection system triggers a current that exceeds the component ratings (12A for the inductor).

$$Power\ Rating = V_{OUT} * (0.8 * I_{CRITICAL})$$

**Table 5-1: Power Rating and Short Circuit Test Data**

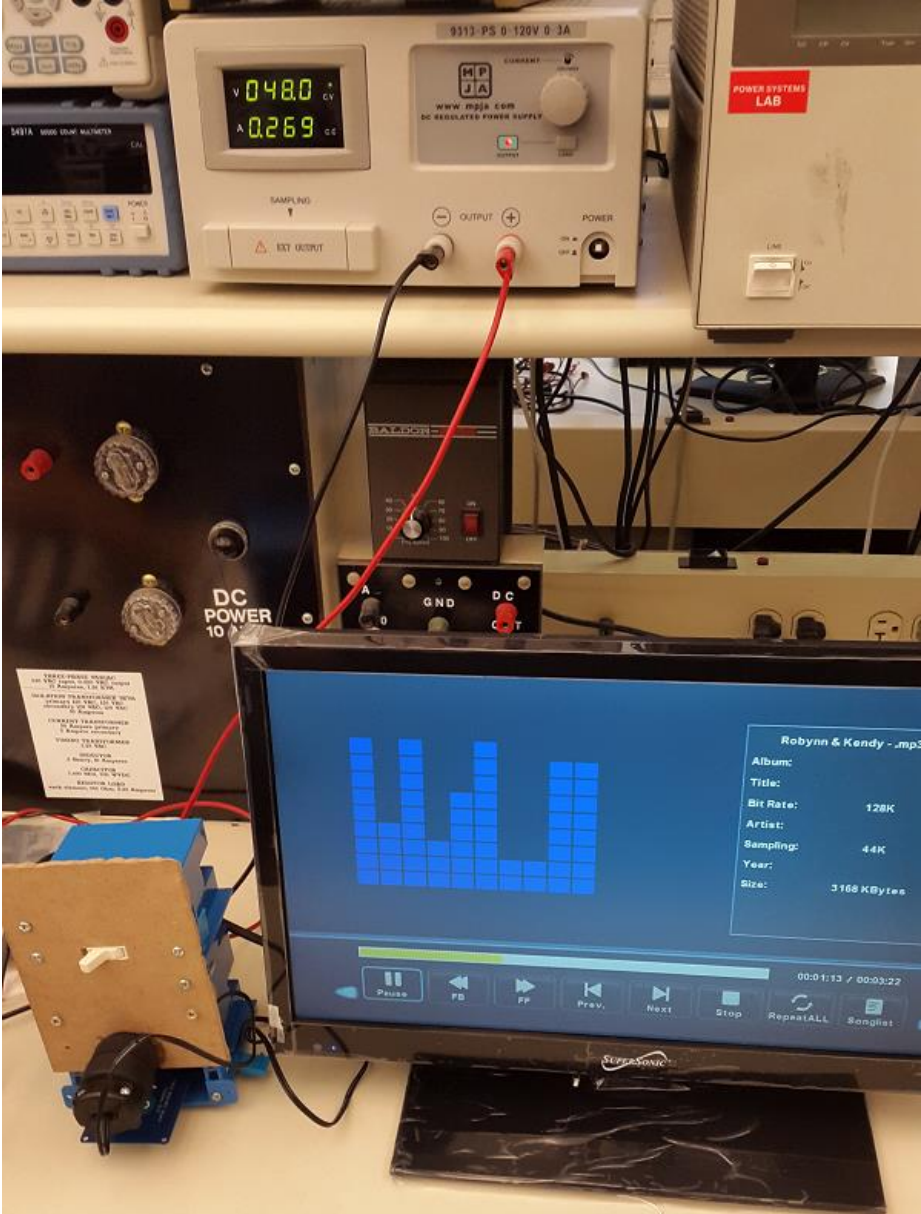
**Table 5-1: Power Rating and Short Circuit Test Data**

ILIM Setting	GND (low power mode)					INTV <sub>CC</sub> (mid power mode)					Floating/N.C. (high power mode)				
VOUT (V)	5	9	12	15	24	5	9	12	15	24	5	9	12	15	24
IMAX (A)	3.8	4.5	4.7	4.6	4.5	N/A	N/A	N/A	N/A	N/A	N/A	N/A	N/A	N/A	N/A
ICRITICAL (A)	2.3	3.6	3	3.3	4.1	2.6	3	3.7	4.2	5	3.3	5.3	6.5	5	5.5
POWER RATING (W)	9	26	28	40	79	10	22	36	50	96	13	38	62	60	105

From **Table 5-1** above, it can be seen that the short circuit protection is operational for the  $I_{LIM}$  = GND setting. Also, the power rating is within the range of most appliances and meets our requirement of 100W limit for most cases except for at high outputs.

With all these in check, testing using real appliances can now begin. The four appliances tested were a portable radio, a 2-speed fan, a portable cooler, and a TV. Each appliance was rated at 12V except for the radio, which was rated at 5V. However, each appliance demanded a different load.

Regardless, the DC SWaP was able to successfully power each appliance, such as the TV shown in **Figure 5-6** shown below.



**Figure 5-6 - DC SWaP Powering a TV**

## Chapter 6: Conclusion and Recommendations

In this project, a DC smart wall plug was created which applied theory from previous work. The DC SWaP is able to take 48 V DC from the main power bus of the DC House and convert it down to any voltage level between 5 to 24 volts. The output voltage of the buck converter within the DC SWaP is set through an NFC reading which will be processed by an Arduino and then used to communicate to adjust a digital potentiometer. A total of four DC appliances were tested: a 5V radio, a 12V TV, a 12V cooler, and a 12V fan. With the aid of the DC SWaP, each appliance operates as expected.

Results on the tests conducted on the DC SWaP met requirements described in chapter 3. However, this does not mean that the DC SWaP is flawless. One problem that remains with the DC SWaP currently is that it generates a fair amount of heat when powering the cooler (60W load). Not enough testing has been conducted to observe any side effects, making it a must to investigate in the future. Also, there has been insufficient testing to measure the power consumption of the DC SWaP while idling and the system's load regulation. Along with that, a method to trigger the run pin via software rather than hardware should be implemented as it would facilitate replicating the DC SWaP.

To further improve the DC SWaP, the next step is to integrate the NFC antenna to the front panel of the wall plug and implement a microcontroller on to a single PCB alongside with the DC-DC converters. Integrated components will reduce the overall size as well as manufacturing difficulty. Ideally the wall plug should not have an antenna sticking out of the wall plug which may cause safety concerns. With that, a method to handle two loads simultaneously should be researched as wall plugs can normally handle more than two loads. For example, a SIMO (single inductor multiple output) buck converter topology in conjunction with multiple antennas, instead of one, is another possible solution. Finally, further testing should also be conducted on a larger variety of DC appliances to verify the functionality of the wall plug since only 5V and 12V appliances were tested.

## Reference

- [1] Taufik. "The DC House Project." The DC House Project. N.p., n.d. Web. 01 Dec. 2012. <<http://www.calpoly.edu/~taufik/dchouse/>>.
- [2] E. C. Sibal, "Smart Wall Plug Design for the DC House Project", M.S. thesis, Dept. Electrical Eng., California Polytechnic State Univ., San Luis Obispo, CA, 2012.
- [3] A. Shah, "Poverty Facts and Stats," Global Issues. [On-line]. Jan 7, 2013. Available: <http://www.globalissues.org/article/26/poverty-facts-and-stats>
- [4] Rasmuseen, "AC and DC Power Distribution for Data Centers," APC White Paper #63. [On-line]. Feb 19, 2014. Available: [http://www.apcmedia.com/salestools/SADE-5TNRLG\\_R6\\_EN.pdf](http://www.apcmedia.com/salestools/SADE-5TNRLG_R6_EN.pdf)
- [5] "Physiological Effects of Electricity". All About Circuits. Web. 29 Apr. 2014. <[http://www.allaboutcircuits.com/vol\\_1/chpt\\_3/2.html](http://www.allaboutcircuits.com/vol_1/chpt_3/2.html)>.
- [6] Linear Technology, "LTC 3891 Low IQ, 60V Synchronous Step-Down Controller", Technical Datasheet, 2005. < <http://cds.linear.com/docs/en/datasheet/3891fa.pdf>>
- [7] Taufik; D. Dolan. *Introduction to Power Electronics*. Cal Poly Status University, San Luis Obispo, 2013, pp. 214-332.
- [8] Linear Technology, "LT1676 Wide Input Range, High Efficiency, Step-Down Switching Regulator", Technical Datasheet, 1998. <<http://cds.linear.com/docs/en/datasheet/1676f.pdf>>
- [9] "Arduino Uno" *Arduino*. [On-line]. Available: [http://powerelectronics.com/site-files/powerelectronics.com/files/archive/powerelectronics.com/power\\_management/power\\_ic\\_s/Overcurrent-protection-IC-limits-PET-810.pdf](http://powerelectronics.com/site-files/powerelectronics.com/files/archive/powerelectronics.com/power_management/power_ic_s/Overcurrent-protection-IC-limits-PET-810.pdf) [May 16, 2014].
- [10] Texas Instruments, "Snubber Circuit Design - Practical Tips", Technical Article. < [http://www.ti.com/ww/en/analog/power\\_management/snubber\\_circuit\\_design.html](http://www.ti.com/ww/en/analog/power_management/snubber_circuit_design.html)>

## **APPENDIX A — ANALYSIS OF SENIOR PROJECT DESIGN**

### **1. Summary of Functional Requirements**

The purpose of the Smart Dc Wall plug is to provide an easy-to-use and efficient power source for various loads inside the DC house without manually changing the output voltage. Customer needs dictates that the Smart DC Wall plug shall power at least two various household items with voltage ratings between 5V to 24V, such as clocks and radios, at maximum efficiency. Moreover, it shall include short circuit, overvoltage, and reverse polarity protection for the customers' protection as well as increased product lifespan [2]. Other considerations taken into account include the maximum power output of the wall plug shall not exceed 50 watts and the output voltage is within 5% difference of the load nominal input voltage. For customer convenience, the outlet must have a clear distinction that only DC appliances in a certain orientation may be used.

In summary, the Smart DC Wall plug shall:

- transform 48V from a central DC power line into a variable voltage (5-24V)
- automatically detects and outputs the load voltage required to operate various household appliances to within 5% difference of nominal values
- consume little or no power with no load
- supply DC power to a minimum of 2 loads simultaneously
- operate only with DC appliances, no AC appliances

### **2. Primary Constraints**

The primary constraint in this project is to redesign the DC-DC conversion stage to meet the large range of output requirements while maintaining high efficiency. The output rating of the previous

design only rated at 50W with 15V and 9A maximum output [2]. It is nearly impossible to maintain constant efficiency because DC-DC converters in general have more loss when the potential between input and output increases (e.g. 48V to 5V). The smart DC wall plug only works as a constant voltage power supply, therefore any loads requiring constant current is not compatible with the wall plug. Another constraint would be the limiting number of loads the system can handle each time; each load requires at least 1 DC-DC converter and a control signal from the microcontroller.

### 3. Economic

The experiment requires two electrical engineering students and an advisor with experience in the power electronics field. The project has an estimated cost of \$100 which is paid for by the student and later reimbursed by Cal Poly.

As a non-profit project, the DC house may not gain any substantial profit. Any profit directly generated from the project will be used to improve the smart wall plug and the DC house. The project indirectly generates benefits by providing better living environment thus increase productivity. **Table 3** below elaborates more on the economic impacts of the smart DC wall plug.

**Table A-1 - Types of Economic Capitals and Their Impacts Relative to the Smart DC Wall Plug**

<b>Capital</b>	<b>Impact</b>
<b>Human</b>	The product supports the renewable energy market, creating jobs in the related field. Includes, and is not limited to, product design improvement, assembly, testing, and maintenance.
<b>Financial</b>	Since the product's main source of power is to be DC power generated from renewable sources, the product saves money in the long run. The benefits mimic those of a solar panel.
<b>Manufactured/Real</b>	This product requires machinery to enter mass production, test fixtures to test it, and tools for maintenance.
<b>Natural</b>	As the main source of DC power comes from renewable energy sources, using this product will protect Earth's natural resources such as coal and petroleum in the long run.

**Costs accrue at:**

- Designing the product
- Manufacturing the product
- Shipping the product
- Installing the product

**Benefits accrue at:**

- Using the product
- Using DC power instead of AC saves Earth’s natural resources

**4. If manufactured on a commercial basis:**

If the DC smart wall plug were manufactured on a commercial basis, the sales number is correlated to the number of DC house being build each year and the power rated for each house. For example, if the DC House were to supply 300W total, there would need to be at least six wall plugs at 50W each if full load were to be drawn at any given point. Since the product is mainly targeting 3<sup>rd</sup> world country market, very low profit will be made. Similar to most electronic products, the estimate life time of the smart wall plug is around 10 years. Small upgrades will be made at least every 3 years to make sure it will compatible to newer DC appliances. The operation cost for the product should cost no more than the price of the product and installation fee with the life time of the wall plug. Purchase price for the wall plug would have to be low enough to allow for purchase by the low-income families that would most likely be attempting to buy or build a DC House. **Table 4** below shows estimations of these values.

**Table A-2 - Manufacturing Estimates**

Estimated number of devices sold per year:	<b>500</b>
Estimated Manufacturing cost for each device	<b>\$50</b>
Estimated purchase price for each device	<b>\$55</b>
Estimated profit per year	<b>\$2,500</b>
Cost for user to operate device (per unit time)	<b>&gt;\$5.00/Mo</b>



## **5. Environmental**

Manufacturing the product harms nature as it incorporates the use of ICs and PCBs which leaves behind a large carbon footprint. This destroys the environment around the factories and locations near where the production waste is stored. Species impacted are those living within the vicinity of the locations described previously. However, all parts used are RoHS compliant, meaning they are free of hazardous substances. Regarding disposal, the circuit board can be recycled using modern PCB recycling methods for recovering valuable metals and other materials. Additionally, the receptacle and electrical box can both be used in other applications and are not specific to this design.

In an indirection fashion, the DC house project protects the environment by reducing the consumption of petroleum and other natural gases as a main power source. Instead, the project incorporates renewable energy power generators, such as portable water turbines or solar panels.

## **6. Manufacturability**

The PCB used in the design of the wall plug is a standard, double-layer board, and could be easily produced by automated processes should large-scale production be warranted. The resulting printed circuit board assembly could also be produced by automation, and thus reduce both production time and cost substantially. The most significant challenge in manufacturing the wall plug is setting up standard for the RFID tag information in the plug so that companies that make DC appliance could follow. A secondary issue is being able to decrease cost to an affordable level relative to those in third world countries. This issue will be most likely addressed in the transition from the prototyping phase to production phase of the DC house.

## 7. Sustainability

Referring to the “Four E’s of Sustainability:” Energy, Environment, Economics, and Equity, the DC House Project is an ideal example of using these concepts together in order to improve the health, comfort, and safety of many through the use of renewable energy. The design improvement increases the power efficiency of the load.

Since the project is to be implemented in third world countries, its design specifications include being durable not easily tampered with. If the wall plug requires maintenance, then it shall be simple and kept to the minimal so the users will be able to do so themselves without difficulty. Ideally, the wall plug would have a lifetime of over 20 years. All the parts used in the plug are RoHS compliant, and by using the minimal number of components without adding superfluous functionality, the wall plug is an environmentally-friendly device. In addition, the materials used are easily recycled by modern electronics reclamation facilities.

The benefits of using the DC House with the Smart Wall Plug has equitable benefits for the world, as the adoption of this technology will lead to further developments in low-power appliances, reduced greenhouse gas emissions, decreased accidents from fuel handling, and decreased sickness from generator emissions. Implementing this kind of technology in developing nations promotes the use of renewable resources and cuts back on the consumption of fossil fuels. Renewable energy would be gradually implemented and accepted as countries using DC houses grows economically and industrially.

Upgrades for the small DC wall plug include changing the RFID tag/reader to have an algorithm to determine the correct output voltage. A manual switch or button to turn off the smart DC wall plug reduces overall power consumption.

## **8. Ethical**

The Smart DC Wall Plug was constructed with the highest ethical considerations in mind, as it is part of DC House project which aims to bring clean, renewable power to those unfortunate enough to go without. As with the case of any electronics project, the impact of harmful chemicals was taken into consideration and minimized with the use of RoHS compliant parts, and hardware that is easily recyclable and reusable for other applications.

The smart DC wall plug is ethical because it is a necessary part of the DC house project, which is designed to address the lack of electricity in third world countries. This relates to the IEEE code of ethics stating to help the public and to treat all persons fairly, regardless of race or national origin. However, since not every village will be able to afford remodeling every house into a DC house, it will create an inequality between those who do and those who don't.

## **9. Health and Safety**

As with all electrical wall outlets, sticking any body part into the plug or any non-insulated metal into the wall plug can cause in a worst case scenario, heart failure due to electrical shock. As large currents running through the human body causes heart failure, we implement short circuit protection to prevent any large current from leaving the wall plug. We also implemented reverse polarity protection to prevent any appliance from being connected incorrectly. Other safety concerns can be related to the standard 120V AC wall plug and are not unique to the Smart DC wall plug.

## **10. Social and Political**

Approximately 1.6 billion people, a quarter of the human population, live without electricity [3]. The project mainly focuses on decreasing this number by providing low-cost means of providing electricity to third world countries. Those who manufacture and those who use this product are the direct stakeholders. Indirect stakeholders are the AC power companies, for more people using DC

power means less people using AC power, resulting in a decrease in profit for the AC power companies. Every year, governments around the globe write legislatures for new incentives for development of renewable resources. As a result of this, the solar industry alone has grown by 847% from 2000 to 2007[1].

In summary, goal of the DC house is to provide electrical equality for all, to provide electricity for those who don't have electricity in their daily lives.

## **11. Development**

- To aid in the assembly process we learned PCB design
- As design requirements dictate, we learned the operations and integration techniques of buck converters
- Simulation techniques for buck converters were learned
- To meet safety requirements, we learned over voltage protection techniques
- To meet safety requirements, we learned reverse polarity protection techniques
- To meet safety requirements, we learned short circuit protection techniques
- For sensing, we learned how to use RFID/NFCs

## APPENDIX B – TEST DATA

**Table C-1 – Power Efficiency Data with Vout = 5V**

Vout = 5					
Iout	Vout(exp)	Iin	Pin	Pout	Efficiency
0.5	4.958	0.081	3.888	2.479	63.76029
1	4.905	0.136	6.528	4.905	75.13787
1.5	4.855	0.19	9.12	7.2825	79.85197
2	4.798	0.248	11.904	9.596	80.61156
2.5	4.747	0.305	14.64	11.8675	81.06216
3	4.693	0.363	17.424	14.079	80.80234
3.5	4.647	0.427	20.496	16.2645	79.35451
4	4.592	0.491	23.568	18.368	77.93618
Average					77.31461

**Table C-2– Power Efficiency Data with Vout = 9V**

Vout = 9					
Iout	Vout(exp)	Iin	Pin	Pout	Efficiency
0.5	8.987	0.122	5.856	4.4935	76.73327
1	8.937	0.219	10.512	8.937	85.01712
1.5	8.888	0.315	15.12	13.332	88.1746
2	8.839	0.414	19.872	17.678	88.95934
2.5	8.788	0.511	24.528	21.97	89.5711
3	8.738	0.614	29.472	26.214	88.94544
3.5	8.687	0.715	34.32	30.4045	88.5912
4	8.637	0.817	39.216	34.548	88.0967
Average					86.7611

**Table C-3 – Power Efficiency Data with Vout = 12V**

Vout = 12					
Iout	Vout(exp)	Iin	Pin	Pout	Efficiency
0.5	12.11	0.154	7.392	6.055	81.91288
1	12.05	0.284	13.632	12.05	88.39495
1.5	12.01	0.413	19.824	18.015	90.8747
2	11.95	0.544	26.112	23.9	91.5288
2.5	11.91	0.674	32.352	29.775	92.0345
3	11.85	0.807	38.736	35.55	91.77509
3.5	11.81	0.944	45.312	41.335	91.22308
4	11.75	1.079	51.792	47	90.74761
Average					89.81145

**Table C-4 – Power Efficiency Data with Vout = 15V**

Vout = 15					
Iout	Vout(exp)	Iin	Pin	Pout	Efficiency
0.5	15.05	0.185	8.88	7.525	84.74099
1	14.99	0.346	16.608	14.99	90.25771
1.5	14.96	0.505	24.24	22.44	92.57426
2	14.9	0.667	32.016	29.8	93.07846
2.5	14.85	0.829	39.792	37.125	93.29765
3	14.8	0.992	47.616	44.4	93.24597
3.5	14.76	1.155	55.44	51.66	93.18182
4	14.72	1.321	63.408	58.88	92.85895
Average					91.65447

**Table C-5 – Power Efficiency Data with Vout = 24V**

Vout = 24					
Iout	Vout(exp)	Iin	Pin	Pout	Efficiency
0.5	24.38	0.282	13.536	12.19	90.05615
1	24.34	0.541	25.968	24.34	93.73075
1.5	24.31	0.797	38.256	36.465	95.31838
2	24.26	1.058	50.784	48.52	95.5419
2.5	24.22	1.317	63.216	60.55	95.78271
3	24.17	1.58	75.84	72.51	95.60918
3.5	24.14	1.841	88.368	84.49	95.61153
4	24.08	2.106	101.088	96.32	95.28332
Average					94.61674

**Table C-6 – Line Regulation Data with V<sub>OUT,LOW</sub> = 38V, V<sub>OUT,HIGH</sub> = 58V, and I<sub>OUT</sub> = 3A**

Vout,nom (V)	5	9	12	15	24
Vout,low (V)	4.702	8.745	11.85	14.81	24.18
Vout,high (V)	4.692	8.731	11.83	14.78	24.15
Line Reg.	0.2000%	0.1556%	0.1667%	0.2000%	0.1250%

## APPENDIX C – ARDUINO CODE

### Code 1: Arduino Code for Wall Plug

```
#include <Wire.h>
#include <Adafruit_NFCShield_I2C.h>
#include <SPI.h>

#define IRQ (2)
#define RESET (3) // Not connected by default on the NFC Shield

Adafruit_NFCShield_I2C nfc(IRQ, RESET);

int runpin =12;

void setup(void) {
  Serial.begin(115200);
  Serial.println("Hello!");
  pinMode(runpin, OUTPUT);
  digitalWrite(runpin, HIGH); //Resets run pin on Buck controller
  nfc.begin();
  Wire.begin();
  uint32_t versiondata = nfc.getFirmwareVersion();
  if (! versiondata) {
    Serial.print("Didn't find PN53x board");
    while (1); // halt
  }
  // Got ok data, print it out!
  Serial.print("Found chip PN5"); Serial.println((versiondata>>24) & 0xFF, HEX);
  Serial.print("Firmware ver. "); Serial.print((versiondata>>16) & 0xFF, DEC);
  Serial.print('.'); Serial.println((versiondata>>8) & 0xFF, DEC);
  // configure board to read RFID tags
  nfc.SAMConfig();
  Serial.println("Waiting for an ISO14443A Card ...");
}

void loop(void) {
  uint8_t success;
  uint8_t uid[] = { 0, 0, 0, 0, 0, 0, 0 }; // Buffer to store the returned UID
  uint8_t uidLength; // Length of the UID (4 or 7 bytes depending on ISO14443A card type)
  char value[] = "";
  double value2; //Voltage reading from Tag
  int value3; //Step level data, sent to Digital Potentiometer
  byte val = 0;

  // Wait for an ISO14443A type cards (Mifare, etc.). When one is found
  // 'uid' will be populated with the UID, and uidLength will indicate
  // if the uid is 4 bytes (Mifare Classic) or 7 bytes (Mifare Ultralight)
```

```

success = nfc.readPassiveTargetID(PN532_MIFARE_ISO14443A, uid, &uidLength);

if (success) {
  // Display some basic information about the card
  Serial.println("Found an ISO14443A card");
  Serial.print(" UID Length: ");Serial.print(uidLength, DEC);Serial.println(" bytes");
  Serial.print(" UID Value: ");
  nfc.PrintHex(uid, uidLength);
  Serial.println("");

  if (uidLength == 4)
  {
    // We probably have a Mifare Classic card ...
    Serial.println("Seems to be a Mifare Classic card (4 byte UID)");

    // Now we need to try to authenticate it for read/write access
    // Try with the factory default KeyA: 0xFF 0xFF 0xFF 0xFF 0xFF 0xFF
    Serial.println("Trying to authenticate block 4 with default KEYA value");
    uint8_t keya[6] = { 0xFF, 0xFF, 0xFF, 0xFF, 0xFF, 0xFF };

    // Start with block 4 (the first block of sector 1) since sector 0
    // contains the manufacturer data and it's probably better just
    // to leave it alone unless you know what you're doing
    success = nfc.mifareclassic_AuthenticateBlock(uid, uidLength, 4, 0, keya);

    if (success)
    {
      Serial.println("Sector 1 (Blocks 4..7) has been authenticated");
      uint8_t data[16];
//Reading data below
      // Try to read the contents of block 4
      success = nfc.mifareclassic_ReadDataBlock(4, data);

      if (success)
      {
        // Data seems to have been read ... spit it out
        Serial.println("Reading Block 4:");
        nfc.PrintHexChar(data, 16);
        Serial.println("");
        // Wait a bit before reading the card again
        delay(10);
        int i=0;
        for(i=0; i<16; i++){
          value[i] = (char)data[i];
        }
        value2 = atof(value);
        Serial.println(value2);
        if (value2 >=5 & value2 <=24) //See if valid voltage range

```



```

{
  value3 = ((1314/((value2/.8)-1))-1); //converting voltage to step level
  Serial.println(value3);
  Wire.beginTransmission(47); // transmit to device #44 (0x2c)
    // device address is specified in datasheet
  Wire.write(byte(0x02)); // sends instruction byte
  Wire.write(value3); // sends potentiometer value byte
  Wire.endTransmission(); // stop transmitting
  digitalWrite(runpin, LOW); //Sets the run pin high to tell the Buck controller to begin output
  delay(10);
}
else
{
  Serial.println("Oops... the voltage rating of the appliance is not supported! This DC SWaP only
supports appliances operating between 5V-24V.");
  digitalWrite(runpin, HIGH); //Resets run pin on Buck controller
}
}
else
{
  Serial.println("Oops ... unable to read the requested block. Try another key?");
  digitalWrite(runpin, HIGH); //Resets run pin on Buck controller
}
}
else
{
  Serial.println("Oops ... authentication failed: Try another key?");
  digitalWrite(runpin, HIGH); //Resets run pin on Buck controller
}
}
if (uidLength == 7)
{
  // We probably have a Mifare Ultralight card ...
  Serial.println("Seems to be a Mifare Ultralight tag (7 byte UID)");

  // Try to read the first general-purpose user page (#4)
  Serial.println("Reading page 4");
  uint8_t data[32];
  success = nfc.mifareultralight_ReadPage (4, data);
  if (success)
  {
    // Data seems to have been read ... spit it out
    nfc.PrintHexChar(data, 4);
    Serial.println("");

    // Wait a bit before reading the card again
    delay(10);
    int i=0;

```



```

}
// Got ok data, print it out!
Serial.print("Found chip PN5"); Serial.println((versiondata>>24) & 0xFF, HEX);
Serial.print("Firmware ver. "); Serial.print((versiondata>>16) & 0xFF, DEC);
Serial.print('.'); Serial.println((versiondata>>8) & 0xFF, DEC);

// configure board to read RFID tags
nfc.SAMConfig();

Serial.println("Waiting for an ISO14443A Card ...");
}

void loop(void) {
  uint8_t success;
  uint8_t uid[] = { 0, 0, 0, 0, 0, 0, 0 }; // Buffer to store the returned UID
  uint8_t uidLength; // Length of the UID (4 or 7 bytes depending on ISO14443A card type)
  char value[] = "";
  double value2; //Voltage reading from the NFC

  byte val = 0;

  // Wait for an ISO14443A type cards (Mifare, etc.). When one is found
  // 'uid' will be populated with the UID, and uidLength will indicate
  // if the uid is 4 bytes (Mifare Classic) or 7 bytes (Mifare Ultralight)
  success = nfc.readPassiveTargetID(PN532_MIFARE_ISO14443A, uid, &uidLength);

  if (success) {
    // Display some basic information about the card
    Serial.println("Found an ISO14443A card");
    Serial.print(" UID Length: ");Serial.print(uidLength, DEC);Serial.println(" bytes");
    Serial.print(" UID Value: ");
    nfc.PrintHex(uid, uidLength);
    Serial.println("");

    if (uidLength == 4)
    {
      // We probably have a Mifare Classic card ...
      Serial.println("Seems to be a Mifare Classic card (4 byte UID)");

      // Now we need to try to authenticate it for read/write access
      // Try with the factory default KeyA: 0xFF 0xFF 0xFF 0xFF 0xFF 0xFF
      Serial.println("Trying to authenticate block 4 with default KEYA value");
      uint8_t keya[6] = { 0xFF, 0xFF, 0xFF, 0xFF, 0xFF, 0xFF };

      // Start with block 4 (the first block of sector 1) since sector 0
      // contains the manufacturer data and it's probably better just
      // to leave it alone unless you know what you're doing
      success = nfc.mifareclassic_AuthenticateBlock(uid, uidLength, 4, 0, keya);
    }
  }
}

```

```

if (success)
{
  Serial.println("Sector 1 (Blocks 4..7) has been authenticated");
  uint8_t data[16];
//writing data below
  // the following line is written out to the NFC tag and this text should be read back in a minute
  memcpy(data, (const uint8_t[]){ '1', '2', '.', '0', '0', '0', '0', '0', '0', '0', '0', '0', '0', '0', '0', '0' }, sizeof data);
  success = nfc.mifareclassic_WriteDataBlock (4, data);

//Reading data below
  // Try to read the contents of block 4
  success = nfc.mifareclassic_ReadDataBlock(4, data); //Read block 4 data

  if (success)
  {
    // Data seems to have been read ... spit it out
    Serial.println("Reading Block 4:");
    nfc.PrintHexChar(data, 16);
    Serial.println("");
    // Wait a bit before reading the card again
    delay(1000);
    int i=0;
    for(i=0; i<16; i++){
      value[i] = (char)data[i];
    }
    value2 = atof(value);
    Serial.print ("Voltage Rating (V) written to NFC TAG:"); Serial.println(value2);
    Serial.println("");
    delay(10);

  }
  else
  {
    Serial.println("Ooops ... unable to read the requested block. Try another key?");
  }
}
else
{
  Serial.println("Ooops ... authentication failed: Try another key?");
}
}

if (uidLength == 7)
{
  // We probably have a Mifare Ultralight card ...
  Serial.println("Seems to be a Mifare Ultralight tag (7 byte UID)");
}

```

```

// Try to read the first general-purpose user page (#4)
Serial.println("Reading page 4");
uint8_t data[32];
success = nfc.mifareultralight_ReadPage (4, data); //Write to page 4
if (success)
{
  // Data seems to have been read ... spit it out
  nfc.PrintHexChar(data, 4);
  Serial.println("");

  // Wait a bit before reading the card again
  delay(1000);
  int i=0;
  for(i=0; i<16; i++){
    value[i] = (char)data[i];
  }
  value2 = atof(value);
  Serial.print("Voltage Rating (V) written to NFC TAG:"); Serial.println(value2);
  Serial.println("");
  delay(10);
}
else
{
  Serial.println("Ooops ... unable to read the requested page!?");
}
}
}
}
}

```