

Adaptive Basketball Shooter Final Project Report

June 10, 2014

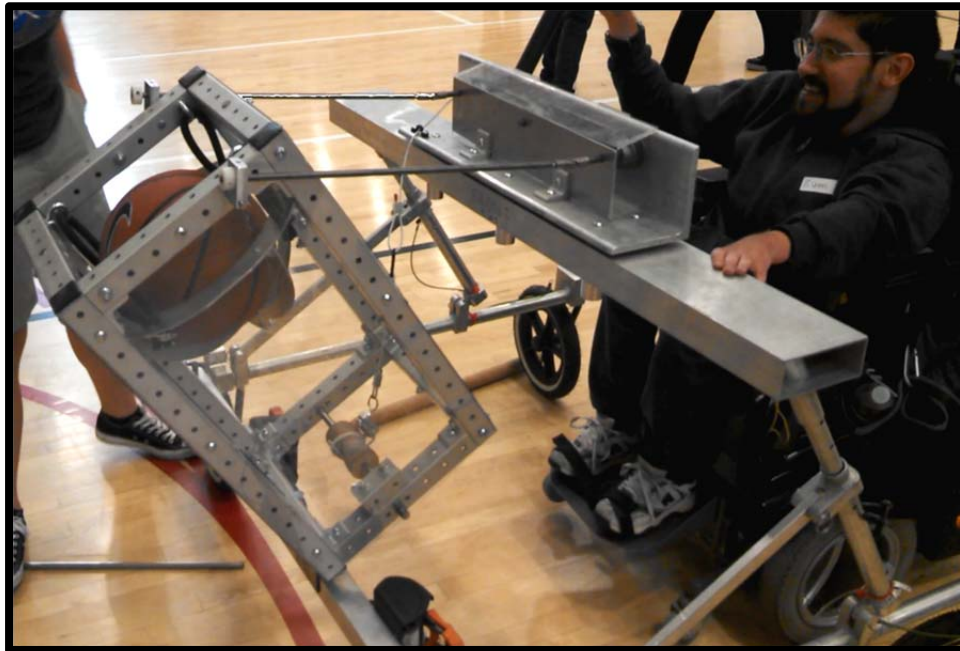

**Sponsor: Special Olympics Regional Sports Manager
Michael Lara**

Team: UPF Ballers

Jenna Becker
Mechanical Engineering
jnbecker@calpoly.edu

Justin Haley
Kinesiology
jdhaley@calpoly.edu

Richard Galanti
Mechanical Engineering
rgalanti@calpoly.edu

Brett Nayudu
Mechanical Engineering
bnayudu@calpoly.edu

Statement of Disclaimer

Since this project is a result of a class assignment, it has been graded and accepted as fulfillment of the course requirements. Acceptance does not imply technical accuracy or reliability. Any use of information in this report is done at the risk of the user. These risks may include catastrophic failure of the device or infringement of patent or copyright laws. California Polytechnic State University at San Luis Obispo and its staff cannot be held liable for any use or misuse of the project.

Acknowledgements

This material is based upon work supported by the National Science Foundation under Grant No. 0756210, "Access by Design: Capstone Projects to Promote Adapted Physical Activity." Any opinions, findings, and conclusions or recommendations expressed in this material are those of the author(s) and do not necessarily reflect the views of the National Science Foundation.

The UPF Ballers would like to thank the following people:

- Dr. Jim Widmann, our Mechanical Engineering faculty advisor
- Dr. Kevin Taylor, our Kinesiology faculty advisor
- Michael Lara, our sponsor and point of contact
- Members of the Friday Club for allowing us to come work with them and observe them
- The mechanical engineering shop techs, for their advice and assistance in manufacturing difficult parts
- Staff of Miner's Ace Hardware for their patience and willingness to provide helpful advice
- Ian Goodyear from Central Coast Creative Cutting for his work on the carriage components

Table of Contents

Statement of Disclaimer	2
Acknowledgements.....	3
List of Figures	7
List of Tables	9
Executive Summary.....	10
Introduction	11
Background and Needs.....	11
Current State of the Art.....	12
Pre-Existing Solutions.....	12
Mechanisms	15
Other Background Research	18
Objectives and Specifications	20
Design Development.....	23
Discussion of Conceptual Designs	23
Concept Selection.....	24
Shooting Method	24
Pull-Back Mechanism	24
Quick-Release Mechanism.....	25
Mounting and Aiming Mechanisms	25
Other Considerations.....	26
Proof of Concept	26
Description of Final Design	27
Overall Description	27
Detailed Design Description	28
Frame Assembly.....	28
Mounting of Frame to UPF	29
Winch Shaft.....	30
Ratchet and Pawl	30
Ratchet Arm Lever	31
Carriage.....	32
Release Mechanism	33

Safety Mechanism.....	33
User Interface	34
Aiming Assembly.....	35
Analysis Results	38
Cost Analysis.....	40
Safety Considerations.....	41
Repair Considerations	41
Product Realization.....	43
Frame.....	43
Bottom Hinges.....	44
Winch Shaft and Components.....	44
Pawl Block.....	46
Table Top	46
Support Plate	47
Carriage	47
U-Joints, Lead Screws, and Lead Screw Hinge.....	48
Safety Casing	48
Release Bracket	49
Cable and Rope Attachments	49
Changes Made During Manufacture.....	50
Stronger Elastic.....	50
Carriage Bending	50
Carriage Top Plate	50
Release Bearings.....	50
Release-Pin Ring	50
Spool Hose Clamp.....	51
Location of Ratchet Arm/Winch Shaft Parts	51
Hex Bolt	51
Winch Shaft Hole for Ratchet Flange	51
Pawl Block Shaft	51
ACME Cylindrical Nut Assembly	52
Clevis Pin Length.....	52

Pulley Sizes and Belts.....	52
Table Top Pegs.....	52
Eye Strap.....	52
Release Lever Length.....	52
U-Channel Set Screws.....	52
Countersunk Screws	53
Design Verification	54
Recommendations and Conclusions.....	56
References	57
Appendix A – QFD and Pugh Matrices	58
QFD (House of Quality).....	58
Pugh Matrices.....	60
Appendix B – Bill of Materials.....	65
Appendix C – Supporting Analysis.....	67
Energy Required to Shoot 3-Pointer	67
Total Potential Energy Required (+ Carriage).....	68
Impact Loading of Frame, Lead Screws, and Base Hinge	69
Finding Reactions due to Impact Force	70
Latex Tubing Energy Storage and Size Selection	72
Static Analysis of Winch Shaft	75
Appendix D – Gantt Chart	78
Appendix E – Drawing Packets.....	80
Appendix F – Operation and Safety Manual.....	134

List of Figures

Figure 1. A photograph of the Miller Twins. Their basketball-shooting device is not shown.	12
Figure 2. A flywheel-style shooter is depicted above.	12
Figure 3. An Ohio University mechanical engineering student tests the team's basketball launcher.	13
Figure 4. Patent sketch of "Sports ball launcher," patented by Christopher L. Hansen	14
Figure 5. Shoot-A-Way Rebound Machine.	14
Figure 6. Pool Lounge Chair	15
Figure 7. Concept Drawing of Firing Angle Change Mechanism for a cannon	15
Figure 8. A motor-operated winch	16
Figure 9. 3-Ring Quick Release	16
Figure 10. Spring-Loaded Slingshot Release	17
Figure 11. Solid Model of a Dog Clutch	17
Figure 12. Dimensions of a NCAA regulation basketball court	18
Figure 13. Universal Play Frame (UPF)	19
Figure 14. Dimensions of the UPF table holes for device attachment.	19
Figure 15. Sketches depicting possible attachment to the UPF Table Top for a catapult and flywheel, respectively	23
Figure 16. Small-scale functional models of a catapult and slingshot, respectively	23
Figure 17. Latex Tubing, a type of elastic band	24
Figure 18. A table-top mounted device versus a lower-bar mounted device	25
Figure 19. The total assembly of the adapted basketball launcher.	27
Figure 20. Frame subassembly.	28
Figure 21. Frame attaching to the UPF by hinges.	29
Figure 22. Winch shaft assembly, with ratchet and pawl.	30
Figure 23. Ratchet arm lever extends from bottom of frame.	31
Figure 24. Carriage assembly.	32
Figure 25. Release mechanism in the attached position.	33
Figure 26. The user interface allows an athlete to have as much control of the system as possible from a wheelchair position.	34
Figure 27. Working portion of tabletop mount showing support fin	35
Figure 28. Pulley system for aiming mechanism.	36
Figure 29. Universal joint that will allow for the transmission of torque to	36
Figure 30. Lead screw of aiming mechanism which controls the tilt of the device.	37
Figure 31. Custom bracket containing cylindrical nut to guide the lead screw as it is turned and allows the device to tilt.	37
Figure 32. In order to drill precise holes in our frame members, the mill was used.	43
Figure 33. All short frame members cut to length with holes drilled.	43
Figure 34. The steel rectangle was Mig welded to the custom u-channel.	44
Figure 35. The bottom hinge assembled to both the frame and the u-channel.	44
Figure 36. The ratchet flange attaches to the winch shaft via a set screw.	45
Figure 37. To attach the ratchet gear to its flange, four holes were milled and threaded.	45
Figure 38. The spool attaches to the winch shaft via a set screw. The winch rope is secured around the spool through another hole.	45
Figure 39. The pawl block assembly mounts two a frame member with two long bolts.	46
Figure 40. The table top assembly, with the pegs attached to the angle stock, is shown. The assembly fits into the holes shown in the UPF.	46
Figure 41. The carriage pieces were cut and bolted together with	47
Figure 42. U-joints attached to the pulley shafts, and the lead screws above them	48
Figure 43. Lead screw hinges with the ACME nut imbedded	48
Figure 44. Back safety casing with the release cable slots	48
Figure 45. Release bracket, freshly milled and tapped, with the pull pin installed.	49
Figure 46. Testing at the Friday Club	55

<i>Figure 47. The Engineering Team at the Senior Project Expo</i>	55
<i>Figure 48. FBD of the frame at impact, with relevant dimensions.</i>	70
<i>Figure 49. Testing the elastic available to use for launch.</i>	73
<i>Figure 50. Shear and moment diagram of winch shaft.</i>	75
<i>Figure 51. Effective length for a fixed-fixed beam. Image from Beer's Mechanics of Materials, 6th Ed.</i>	77

List of Tables

<i>Table 1. Engineering Specifications</i>	21
<i>Table 2. Abbreviated Bill of Materials</i>	40
<i>Table 3. Design verification table, listing testing of all components and mechanisms.</i>	54
<i>Table 5. Full Bill of Materials</i>	65
<i>Table 6. Testing the elastic.</i>	72

Executive Summary

The Friday Club is a joint venture between the Cal Poly Kinesiology Department and the San Luis Obispo Special Olympics that offers people with varying degrees of disability the opportunity to meet weekly and learn various sports and games. At Friday Club, athletes in wheelchairs with limited arm strength use devices built by Cal Poly mechanical engineering students in order to participate in various sports. Many devices are designed to attach to the Universal Play Frame (UPF), a wheel-chair attachment. The purpose of this project was to design and build a UPF device that will launch a basketball, so that an athlete can participate in a game of "Horse."

The project was worked on over the course of the 2013-2014 school year. To begin, the team developed a list of objectives for the device to meet and researched existing solutions for various facets of our design. The next step was to generate concepts of our device, and using Pugh matrices, proof of concept testing, and debate to narrow down to a single concept. Next, this concept was transformed into a fully-fledged design backed by engineering analysis. After design approval, all necessary parts and materials were ordered and a prototype was built over a 10 week period. The final prototype was tested with the Friday Club and displayed at the Senior Project Expo on May 31, 2014.

The final device that our team designed is a slingshot that launches the ball by releasing stretched elastic bands. Our design attaches to the UPF at two points, and can be aimed to shoot a basket from anywhere between 5 and 15 feet away. The athlete has the ability to control the direction, power, and release of each shot. The device can be set up in under five minutes by a single person and takes only 30 seconds to reset between shots.

Of all customer requirements that the device was to meet, it only failed to meet one of them. The first was that it should be able to shoot a three-pointer. Unfortunately, our device either did not have strong enough elastic, or did not have enough space to pull back the ball and carriage sufficiently. Therefore, our device can shoot a basket from a maximum of only 15 feet away, or a free throw. Other future recommendations are to strengthen some parts that take high impacts and to reduce the weight of some unnecessarily bulky parts.

Our budget for this project was \$1,500 but over the course of this project our team spent a little over \$1,750. After analyzing our spending, we found that over \$300 was spent because of manufacturing mistakes and mid-construction design changes. If we were to build another device with the exact same design as our final prototype, and with no mistakes, the device would cost about \$1,400.

In this report, our team's entire design process is catalogued in detail. Also enclosed are detailed part drawings for each manufactured part of our final device, as well as a safety and operation manual.

Introduction

Background and Needs

The Friday Club is a joint venture between the Cal Poly Kinesiology Department and the San Luis Special Olympics. Each Friday for three hours, Special Olympic athletes meet with Cal Poly Kinesiology students at the Cal Poly Rec Center and are taught a different sport or form of exercise. This activity allows the athletes to have fun and get physical exercise. In order to allow athletes of varying abilities to play sports together, some athletes require adaptive devices. To design and build these adaptive devices, the Kinesiology Department and SLO Special Olympics turn to Mechanical Engineering (ME) senior project students. In the past, ME senior project groups have constructed devices allowing athletes to participate in a variety of sports and physical activities, including golf, Frisbee, darts, and baseball.

Michael Lara, Regional Manager of the San Luis Obispo Special Olympics, tasked our team with creating an adaptive basketball shooting device. The purpose of this device is to allow an athlete in a joystick-controlled wheelchair to participate in a game of “Horse” with other athletes. While the device should level the playing field, it should also create the Least Restrictive Environment for those athletes. In other words, it should make the fewest adaptations possible, allowing the athletes to perform as much of the activity as they are able. Ideally, this device should allow an athlete to shoot a ball from a variety of distances, from 5 feet away to a distance of 20 feet. Above all, the device should be safe to set up and operate.

Current State of the Art

After receiving our project, the first thing our team did was begin background research. The research fell into two main categories—pre-existing solutions to similar problems, and general information necessary to design our device, including specifications of basketball and court dimensions, as well as dimensions of the Universal Play Frame, which our device must attach to.

Pre-Existing Solutions

Normal for Us: The Miller Twins



Figure 1. A photograph of the Miller Twins. Their basketball-shooting device is not shown.

While not depicted in Figure 1, in *Normal for Us: the Miller Twins* an adapted basketball launching system is featured that attaches to the side of the wheelchair. It is a catapult-style shooter mounted to the seatback of the chair (behind the user), with an estimated three foot arc length sweep arm. From the video, it was difficult to tell what kind of energy-storage mechanism was used to propel the ball. It could shoot a basket from as far away as half-court. It required assistance to reset the catapult arm, but it was aimed and shot by the athlete. However, due to the mounting of the catapult to the wheelchair, it is impossible to see the basketball before it is shot, meaning the athlete cannot see how he or she has the basketball aimed.

FIRST Robotics Competition, 2012 Basketball Launcher (Flywheel)



Figure 2. A flywheel-style shooter is depicted above.

The device shown in Figure 2 is a prototype made by a high school robotics team of a basketball launcher used on a robot to allow it to play Rebound Rumble, a basketball-like game played by R/C robots. In its current form, this is a light, portable device with quick setup time and long-distance power. In a video showing the capabilities of this shooter, it was able to make a basket from further away than the 3-point line. However, this device is not designed to launch a full-size ball. It requires two hands to operate: one to hold and aim the device, and another to feed the ball in. Feeding the ball does require a small range of movement, which is beneficial, but it is unsafe to have one's hands so close to the flywheels, which spin at high speeds.

Ohio University - Basketball Launcher



Figure 3. An Ohio University mechanical engineering student tests the team's basketball launcher.

Figure 3 shows a slingshot-style launcher, produced by an Ohio University mechanical engineering design team in 2010. It is designed to be operated by a wheelchair athlete with muscular dystrophy. The device can shoot a basketball from between the free throw and 3-point lines. It resets via motor in about thirty seconds, and is structurally sound. However, it requires two hands to operate: one to aim and one to release the ball. In order to operate, the device requires that the athlete have a range of motion of about 2 feet in each arm, and requires a pushing motion on the lever to release the object. It parks next to the wheelchair and is operated from the side.

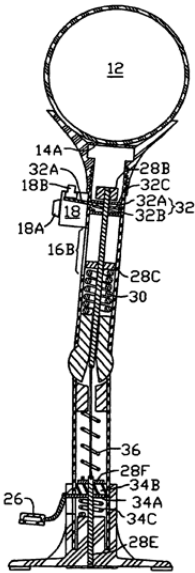

Spring-Loaded Ball Launcher- Patent US7028682

This system, shown in Figure 4, was only found as a patent, not as an actual device. The documentation describes the device as a mechanism that will launch an inflatable ball, such as a basketball, volleyball, or soccer ball. This device stands on the ground. The purpose of this mechanism is to initiate a jump-ball at the start of a game. The internal springs are compressed via foot-pump action by the user. The stored potential energy is released by the athlete. The device can be aimed, but does not seem to be designed with athletes with disabilities in mind. Foot power is required, but it is likely that this solution could be adapted for hand pumping. It is unknown how safe this device is, or how far it can shoot a basketball.

Figure 4. Patent sketch of “Sports ball launcher,” patented by Christopher L. Hansen

Basketball Rebounder

The system shown in Figure 5 is the only product that is currently commercially available. It is used to catch balls shot by athletes and shoot them back out onto the court. This machine is not designed to shoot a ball into the hoop, only to simulate a teammate passing a ball to an athlete. As a result, it is likely that it cannot shoot a ball high enough to make a basket, because it is not adjustable since it is designed for passing instead. Additionally, the machine is large and bulky. Currently, it is fully automatic, needing no user input to shoot a ball. The machine will shoot a ball as soon as it receives one.



Figure 5. Shoot-A-Way Rebound Machine.

Mechanisms

After researching existing solutions that shoot basketballs, we looked into other components necessary for a successful design. The most important functions were aiming, pull-back, and release mechanisms.

Aiming Mechanisms

Lounge Chair Seatback Angle Adjust



Figure 6. Pool Lounge Chair

Standard pool lounges, like the one shown in Figure 6, have an adjustable seat back that works as a sort of ratcheting system. To move the seatback from the reclined to upright position, the seat-back is merely pulled forward. A linear ratchet system locks the seat back in its current position. One issue with this is that it is more difficult to lower the seat back than it is to raise it. The ratchet system must be pulled up for the system to be lowered back down. This system favors one direction of angle change more than another.

Theoretical System - Cannon Firing Angle Change

In Figure 7, a lead screw causes a large ring gear to rotate against two smaller gears. Because the cannon is attached directly to the large gear, it rotates as the gear rotates. While this system facilitates angle change equally in both directions, the system as a whole is quite large. Additionally large gears are quite expensive to purchase, and so this solution may not be cost effective, especially with our modest budget.

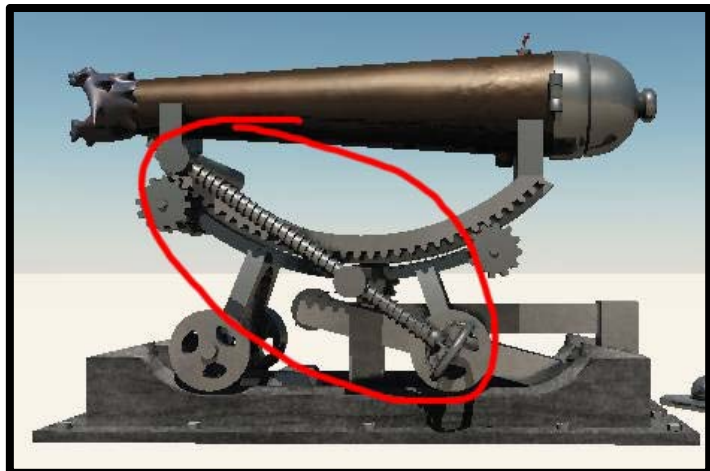

Figure 7. Concept Drawing of Firing Angle Change Mechanism for a cannon

Pull-Back Mechanisms

Winch

The device shown in Figure 8 is used to drag or pull very heavy loads. It is composed mainly of a spool of cable. When one end of the cable is connected to an object, the motor turns the spool, winding the cable up and dragging the object toward the winch. One issue with this idea is that it is electrically-operated. This means that it requires a battery, and the people supervising our machine will have to make sure that the battery is sufficiently charged.



Figure 8. A motor-operated winch

Release Mechanisms

Because our ball must be released by the athlete, it is important that the release mechanism require a fairly light amount of force in order to actuate it. Because of this, our team researched mechanisms that can release high loads with a low amount of force.

Three-Ring Quick Release

Figure 9 shows an intricate series of rings that connect two cables or straps in tension. To separate the two straps, releasing the load, the long thin cable is simply removed. This allows all rings to unfold, finally releasing the largest ring that links the two cables. While this system requires low force to actuate, this system has flaws. First, the nature of this mechanism requires that it be reset after every use. Resetting will take time, which can slow down a game of "Horse." Another issue is how complex the quick release is to reset. In order to use this device, all kinesiology students would have to be trained how to reset this device. If reset incorrectly, the shooter could misfire, potentially harming a bystander.



Figure 9. 3-Ring Quick Release

Slingshot Release

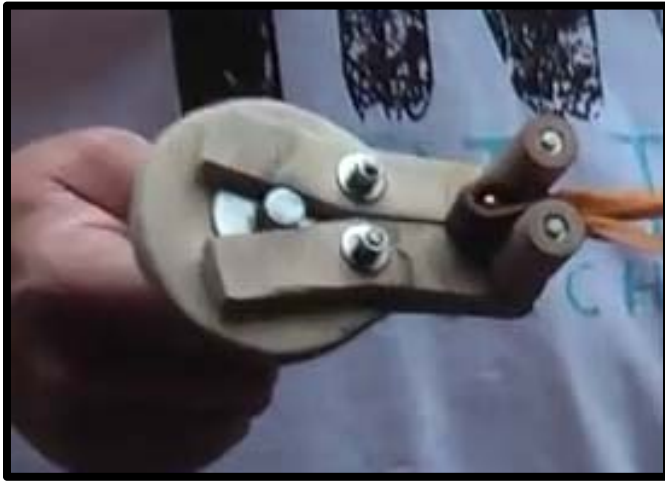

Figure 10. Spring-Loaded Slingshot Release

This mechanism is only compatible with slingshot devices, which limits its use. The end of the elastic, carrying the load, is placed between the two cylindrical pieces on the right. These cylindrical pieces are on swivel arms. Due to the force of the elastic on the cylindrical pieces, the cylinders want to move apart to let it through, but cannot because the circular pin on the left is holding the swivel arms in their current position. To release the slingshot, the pin, which is spring-loaded, is pushed down, allowing the swivel arms to swing. While this is an interesting and seemingly effective system, it contains

many parts and may be time-consuming to manufacture. Additionally, a basketball will not fit behind the cylinders in this mechanism unless the mechanism is made to be gigantic.

Dog Clutch

A Dog Clutch is made up of two interlocking pieces. Each piece, called a dog, is connected to a separate shaft. When interlocked, the two shafts act as one and turn together. When pulled apart, the two shafts can rotate independently of each other. This system can be used to allow a spool of cable to unwind quickly, releasing the ball. This system would require a spool of cable to be used, and would only work with elastic-band powered devices, such as a slingshot or catapult.

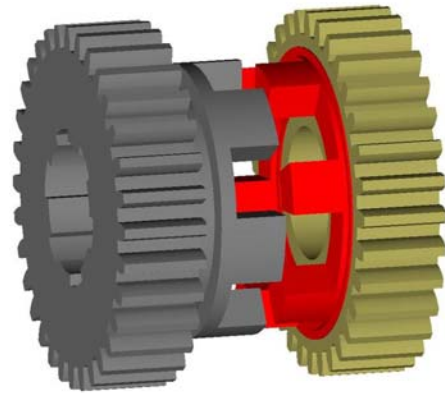

Figure 11. Solid Model of a Dog Clutch

Other Background Research

Basketball and Court Dimensions

For a regulation basketball court, the basket is elevated 10 feet above the ground. In the horizontal direction, the free-throw line is 15 feet away. The three-point line, our distance goal, is 19 feet 9 inches away from the hoop in the horizontal direction. An NCAA men's regulation basketball has a 9-inch diameter and weighs 22 ounces (1.375 pounds).

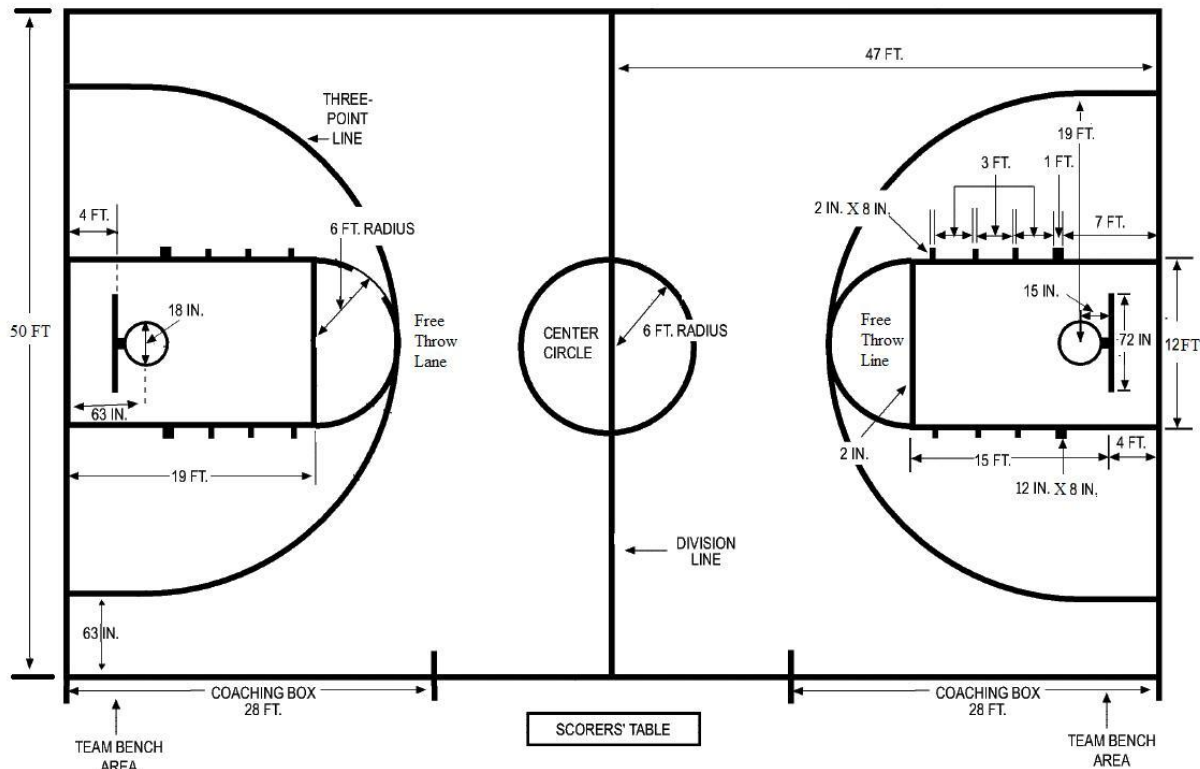

Figure 12. Dimensions of a NCAA regulation basketball court

“Horse”

This device is to be designed so that users can participate in a game of “Horse”. The objective of this game is to take turns shooting baskets until one player makes a shot. At that point, the other players must successfully make a basket from the same place as the first player, or risk elimination from the game. Because this game is turn-based and stationary, this game can be played effectively with an assistive basketball launcher.

Universal Play Frame (UPF)



Figure 13. Universal Play Frame (UPF)

One requirement of this project was that our device must attach to the Universal Play Frame (UPF). The UPF is a structure that attaches to a wheelchair and serves as a mount for adaptive devices. A drawing showing the dimensions of the points of attachment from the UPF to our device is shown below.

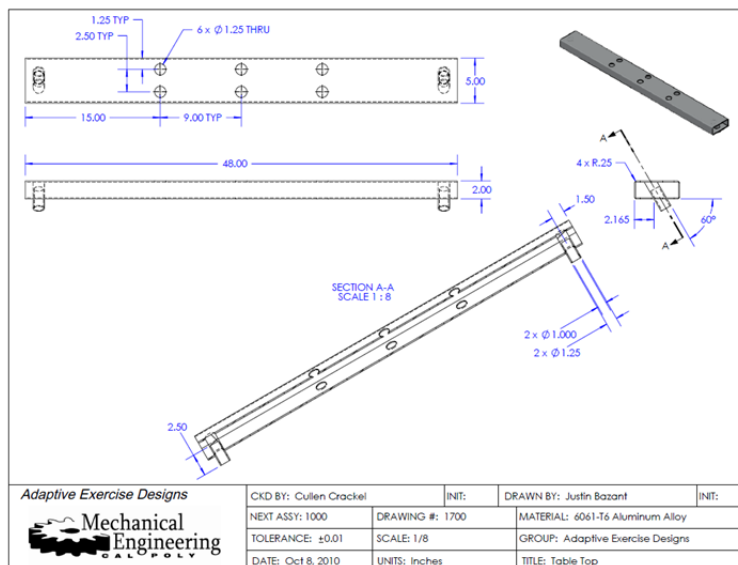

Figure 14. Dimensions of the UPF table holes for device attachment.

User Abilities

Our team attended the Friday Club to meet the athletes and observe their capabilities. This device needed to be tailored to athletes with limited range of motion and strength in their arms. Many of them have limited use of their hands due to muscular atrophy, and so their motion is limited by what their wheelchair can do. Due to this, the strength and range of motion required to operate our device had to be low enough to be used by these athletes, but high enough that they require the athletes to get physical activity.

Objectives and Specifications

The overall goal of this project is to create an adaptive basketball launcher that attached to the Universal Play Frame (UPF) and can be operated by an individual in a wheelchair who has little to no use of their hands or arms. We planned to give these athletes the opportunity to play a game of “Horse” or “Around the World” with their friends.

The first goal is to make it so the individual using our device can not only shoot a basketball, but could play “Horse” at a competitive level. We designed this device to shoot from close range (inside the key) as well as from the three-point arc or potentially even farther. We wanted everyone to feel challenged by one another in order to create the least restrictive environment for all participants involved.

First and foremost, the device needs to be capable of being operated by those who have limited mobility in their arms. One requirement is to have the operation of our launcher require only a six-inch sphere of motion. Whatever actuation mechanism is used, it has to be designed in such a way that the athlete needs to pull six inches at most. But, since many of our target athletes do not have much upper body strength, we also needed to limit the force needed to activate the device and ensure it is in the “ideal direction,” which is a pulling motion towards the user. In order to determine a maximum allowable force, our team measured the force required to pull the release mechanism of other Friday Club adaptive devices. From this testing, it was clear that a maximum allowable force of 5 pounds would ensure that all athletes could operate our shooter. For the athletes that do not have any use of their arms, we planned to allow for an attachment, such as rope, to be securely attached to the release mechanism so it could be tied to the person’s wheelchair. Once attached, they would be able to move in reverse until the launcher activates.

In order to meet the range requirement (to make a basket from as close as 5 feet away and as far as 20 feet away), the launch angle has to be adjustable. Quick calculations were completed to determine the ideal angle necessary to sink a 3-point shot. This angle is roughly 60 degrees above horizontal. Because a higher angle is necessary for a closer shot, the angle of the shooter has to be adjustable to any angle between 60 degrees and 85 degrees above horizontal. Additionally, to satisfy the range requirement, the mechanism has to impart sufficient energy into the ball so that it is launched far enough. Again, from rough calculations we determined that our system needs to provide 20 foot-pounds of energy to the ball in order to ensure that the basketball made it to the hoop. Conducted analysis that led us to the required energy value can be found in Appendix E.

During play, the athlete should be able to see the hoop. To ensure that their line of sight is unimpaired by our launcher, the height of the launcher cannot protrude more than one and a half feet above the UPF Table Top. Once the athlete launches a basketball with the device, we do not want them waiting for several minutes for the launcher to be ready to fire again. Our target reload time is 30 seconds or less so that the athletes does not feel as though he is holding up the game.

In addition to requirements that benefit the user, it is also important to include requirements that take into account the kinesiology students, who set up the equipment for the athletes and oversee its use. One engineering requirement is that the device as a whole can weigh no more than 30 pounds, to facilitate ease of transportation and mounting to the UPF. The launcher also needs to be simple and quick to set up. We needed to make sure that the mounting to the UPF and set up of the basketball shooter takes no more than five minutes. This way, we hoped to maximize the activity time of the athletes.

In Table 1, a summary of all Engineering Specifications are shown. The risk column refers to the risk of meeting each of the specifications. H, M, and L stand for High, Medium, and Low, respectively. The compliance column refers to how each design requirement was to be met. The four methods used here are Analysis (A), Test (T), Similarity to Existing Designs (S), and Inspection (I).

Table 1. Engineering Specifications

Spec. #	Parameter Description	Requirement or Target	Tolerance	Risk	Compliance
1	Weight	30 pounds	Max	L	I
2	Height	1.5 feet	Max	L	I
3	Range	20 feet	Min	H	A, T
4	Set-up Time	5 minutes	Max	L	I
5	Operating Force	5 pounds	Max	M	A, T
6	Reset Time	30 seconds	Max	L	I, A
7	Range of Motion	6 in. dia. Sphere	Max	L	T, S
8	Time Before Maintenance	2 years	Min	M	A
9	Cost	\$1,500	Max	L	I
10	Weight Launched	22 ounces	Min	M	A, T
11	Dia. of Ball Launched	9 inches	Min	L	I
12	Electrical Power Req'd	0 Watts	Max	M	I
13	Storage Size	2 x 2 x 3 ft ²	Max	M	I, T
14	Stored Energy Req'd	20 foot-pounds	Min	H	A
15	Angle (from Horizontal)	60 - 85 degrees	Min - Max	L	I

In order to ensure that all customer requirements were met, our team used Quality Function Deployment (QFD), also called a House of Quality, to check that the engineering specifications we have set guarantee the fulfillment of all customer requirements. This document, which can be found in Appendix A, lays out the goals we set for our design based on the wants and needs of our sponsor Michael Lara and comparing competitor's designs to ours. It also allowed us to view how much certain requirements are dependent on each other and if certain requirements we set for are design are necessary. By physically laying out the requirements for our design with the QFD we had a better idea of which ones are the most important and can focus more on meeting those requirements.

Design Development

Discussion of Conceptual Designs

Our team began our generation of conceptual ideas on a general level. All decisions depended on what type of shooting or launching mechanism was chosen. Several concepts were considered in the beginning, including flywheel, catapult, slingshot, and spring-loaded. Concepts were systematically eliminated as the problem became more clearly understood. To help us understand which methods might work best, we first drew sketches of possible layouts for each. Figure 15 shows examples of sketches illustrating early ideas.

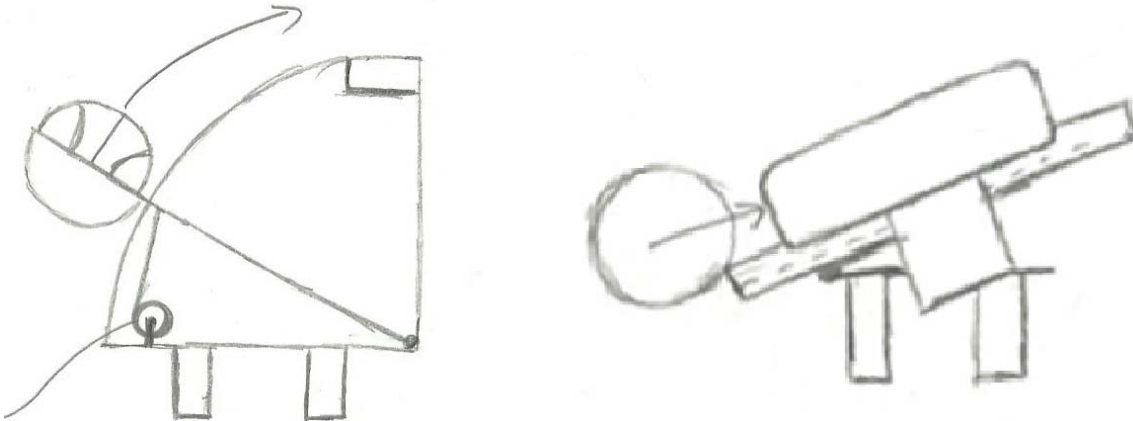

Figure 15. Sketches depicting possible attachment to the UPF Table Top for a catapult and flywheel, respectively

As a team, we also modeled small-scale prototypes for each to determine their relative shooting ability and ease of manufacture. Two examples of these prototypes are shown below in Figure 16.

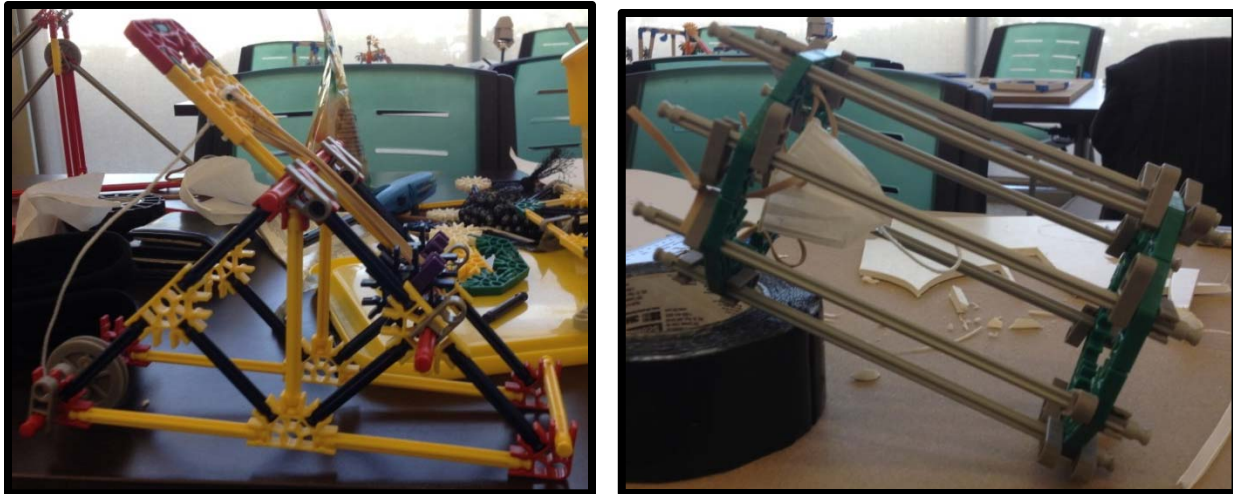

Figure 16. Small-scale functional models of a catapult and slingshot, respectively

Concept Selection

Shooting Method

Of the four initial shooting methods conceived, the spring-loaded idea was thrown out quickly because we decided it would be difficult to compress a spring that could store sufficient energy to shoot a basketball from the three-point line. Safety concerns and space limitations steered the design crew away from the catapult and flywheel, since the athletes would have to be in close proximity to these setups in order to operate the device and could be hurt as a result. A slingshot was seen as the easiest design to contain within a sufficiently compact box, and because of this it would be easy to enclose all but the top of the box to ensure the safety of our users. The concept was then broken down from a general slingshot-style launcher into a handful of mechanisms. Key mechanisms for the design were the quick release, the pull-back, the aiming and the UPF-mounting method.

For each of the mechanisms listed above, a Pugh Matrix was created in order to help with the decision making process. A Pugh Matrix is decision-making tool which lays out many different concepts for a given idea and compares them to a standard which is called a “datum”. Our team formed lists of requirements for each device uses those lists to compare each concept against the datum rate them as either better (+), the same (S), or worse (-) than the datum. In each column, the +’s, -’s and S’s are added up to see the potential of each concept. This is not a definitive way of determining a solution, but rather shows the benefits and deficiencies of each individual concept. Pugh Matrices were created for three separate concepts: the crank mechanism, aiming mechanism and quick release. These matrices are located in Appendix A.

Pull-Back Mechanism

First the pull-back mechanism and the method of energy storage needed to be addressed. The first decision was to determine the energy storage medium, and this came down to using either springs or elastic bands. Between the two, the springs create more pinch-points, and advice from kinesiology professor Dr. Taylor suggested that springs have not been successful on previous adaptive sports senior projects. Elastic bands, however, had been shown to work, as demonstrated by the Ohio University launcher. From there, it was anticipated that a carriage would be needed to hold and carry the basketball in order to ensure it launches properly. Without a carriage, the stored spring energy may not adequately transfer to the ball, which our team confirmed by testing a basic slingshot. Building off of this, the idea of having guide rails to position the carriage was put forward. This is to prevent the ball from misfiring, and to promote straight and consistent shots. The carriage had to be attached to the winch shaft which was able to ratchet back, stretching the elastic bands and storing energy. A ratcheting lever would be attached to the winch shaft in order for the athlete to crank it himself, or a helper could do it if need be.



Figure 17. Latex Tubing, a type of elastic band

Quick-Release Mechanism

Next, the quick-release was investigated, and various ideas were generated: a standard pull pin, a trigger release, a three-ring release, and a dog-clutch. Factors that were most important in the quick-release were the force required to activate it, the space that it consumed and its reset time. The three-ring release and trigger release would require extra parts in order to attach the carriage to the winch shaft, whereas the dog-clutch is a part of the winch shaft itself. With less parts in the design, it would be easier to reset, and more consistent. Weighing these together, the dog-clutch stood out at first as a better solution, and was included in our team's final conceptual design. After discussing with our peers and advisor during our Conceptual Design Review, a few problems were exposed with the dog clutch. One such problem was the large amount of friction that would build up on the dog clutch with the high amount of torque being put on it. Another issue would be that a free spinning winch shaft meant much more energy would be lost through spinning the shaft. Additionally, with a quick-spinning shaft comes the possibility for long hair or clothing to be caught around it, potentially harming the user. As a result, our team decided for a simplistic approach, and planned to use a pull-pin as a release. By using a pull pin, there would still be friction between the pin and carriage, but releasing the pin would not affect the winch shaft, meaning it would no longer spin freely at high speeds.

Mounting and Aiming Mechanisms

Early in the design process we began to consider how to mount our final device to the UPF. Originally, it was thought that the apparatus would be mounted to the table top. This would allow the device to be aimed in two different planes, to adjust the shot arc as well as twist in the horizontal plane (to the left or right). Later in the design process, though, it became apparent that the device would need to be mounted to something other than the top table. In order to store the potential energy necessary to launch a basketball 20 feet, the device would need to accommodate enough pull-back space. The table top was too small for this, however, and putting too large of a setup on the top table would obstruct the view of the athlete, as well as cause potential safety problems. The next most viable option was to mount to the front bar, and use the top table as a stabilizer. This opened up the opportunity to aim the device using lead screws which push and pull from the top table to the device. Layout sketches for the two main methods of mounting are shown in Figure 18.

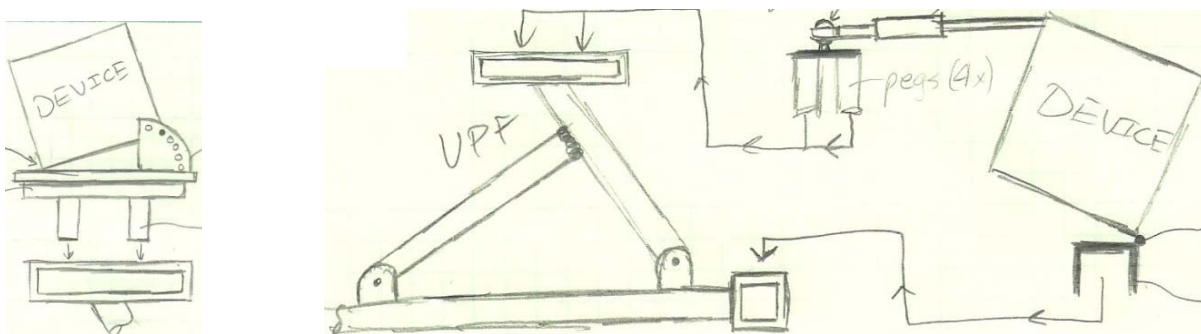

Figure 18. A table-top mounted device versus a lower-bar mounted device

This concept met the requirements of shooting distance and unobstructed view, with the placement of the launcher in the front of the UPF providing ample pull-back space for the elastic bands, and also clearing a line of sight for the athlete to the basket.

Other Considerations

Other major considerations taken into account during the conceptual design phase were wear, noise, and safety concerns. Some of the athletes were timid and frightened by sudden loud noises, so our device should not make a startling noise. Because the carriage would be moving at high speeds, if it was not slowed after releasing the ball the carriage would hit the frame with a large impact. This would both cause a loud noise and could affect the structural integrity of the carriage and supporting frame over time. As a result, our team decided that placing some sort of compression spring or rubber stopper at the top of each guide rail would help to slow down the carriage in a safe and quiet manner.

The safety of the users was important above all else. To address safety concerns we had two protocols in place. First, we decided that there should be walls covering the sides of our shooter and any exposed mechanical parts, to ensure that users cannot access any pinch points or areas of impact. Also, we considered safety mechanisms where a ball cannot be launched accidentally until a specific action was taken by an assistant. The simplest method was to create a way to unhook the athlete's release actuator from the quick-release pin until all participants were ready to shoot and the area in front of the shooter was cleared of any bystanders. Then the assistant would join the user's release actuator and the quick-release by cable, rendering the device live and ready to shoot.

Proof of Concept

Before proceeding any further, we wanted to make sure that our decision to store energy in elastic tubing was a viable method for our design. In order to test whether the tubing would be capable of shooting a basketball from 20 feet we needed a testing apparatus. We decided to make a cube with rear leg extensions to give us a shooting angle of approximately 60° from a horizontal surface. Since we needed to make something quick, but strong, we used 1.5 inch square wood and cut it into two foot segments; two pieces were longer (about 33 inches) and angled at one end to angle the testing apparatus. We created some simple joints so the whole device could be joined with only wood glue. Once it was dried we took our elastic tubing and cut it into four equal parts to have the same setup as our final design. However, instead of using eye-screws and bungee hooks for the elastic bands, we wrapped the tubing around the wood on the top of the frame and tied off the tubing at our makeshift carriage. We then tied a string around the bottom of the carriage so that we could manually pull the ball back to shoot it. After taking several shots and getting use to the device we were able to make a three-point-shot thus proving that the elastic tubing will have sufficient energy storage capabilities and is durable enough to shoot repeatedly and consistently.

Description of Final Design

Overall Description

Our final design mounts to two separate areas of the Universal Play Frame. First, the device sits on hinges attached to the lower front bar of the UPF, which carries the bulk of the assembly's weight. Another section of the device also mounts to the UPF Table Top via long rods that rest in the table top holes. The device itself can be broken into three major subassemblies: the aiming subassembly shooting subassembly, and release subassembly.

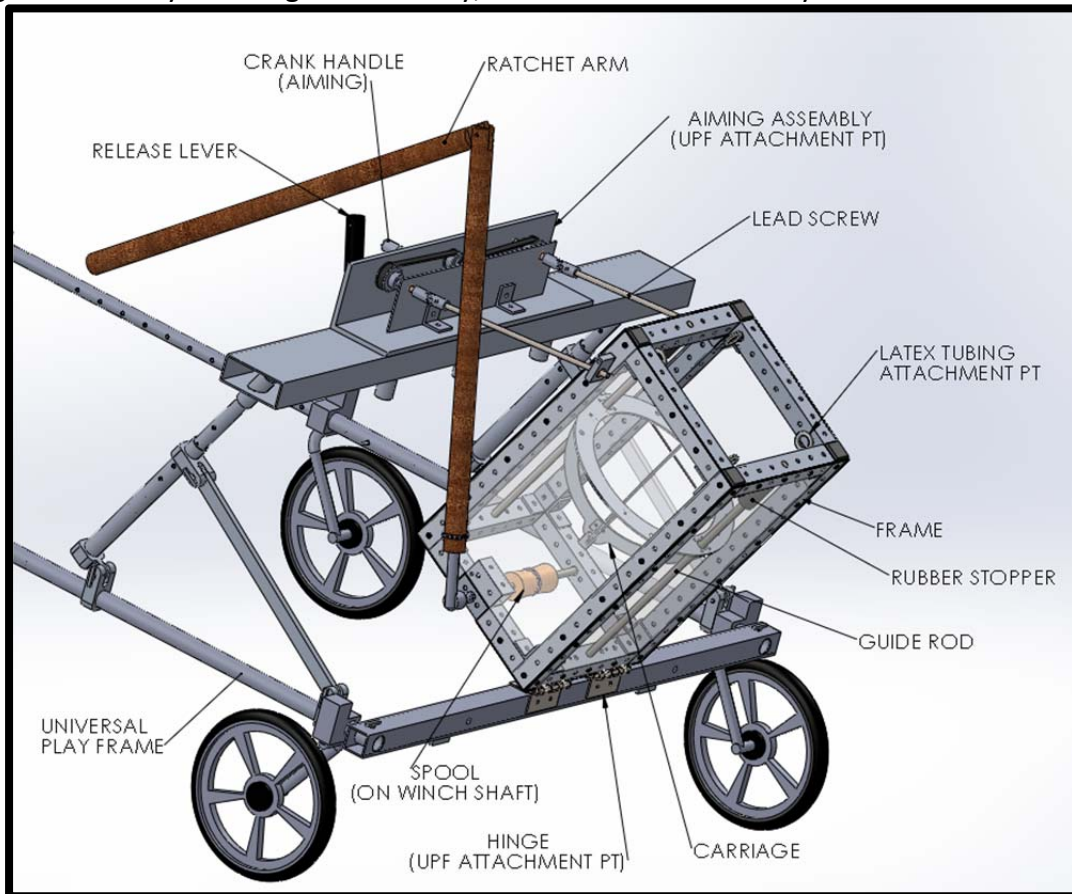

Figure 19. The total assembly of the adapted basketball launcher.

Detailed Design Description

Frame Assembly

The frame sizing was very similar to how it was for the conceptual design. It had a base measuring 13.5" x 13.5", and it is 2 feet tall. It was made out of stock aluminum bolt-together framing, for which there were pre-made holes on all sides for bolting attachment brackets. This was ideal for the design because there are shafts and eye bolts which are fastened along the frame in very specific locations. Loads on the frame were 200 pounds maximum, which was low enough that the structural integrity of the framing need not be questioned. The stock aluminum framing was cut to size, and additional holes were machined to attach the guide rods and winch shaft.

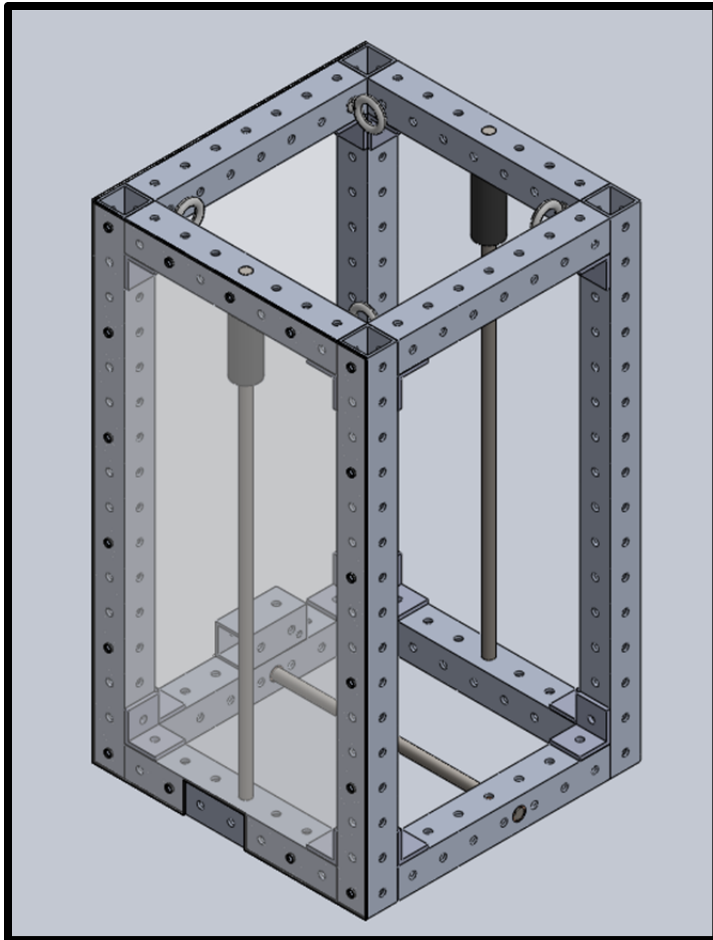

Figure 20. Frame subassembly.

Each of the pre-made holes in the aluminum stock was .328" in diameter, allowing clearance for a 5/16" bolt or rod. The guide rods were 0.5" in diameter, and so larger holes on either side of the frame had to be drilled. During installation, the guide rods touched the frame at four different points, and two bolts ran horizontally through frame members, securing the guide rods into place. This helped ensure the straightness of our rods. While we decided to use two guide rods in our design, we chose between using two, four, or no guide rods. Overall, we decided that it was best to have just two guide rods. Having any even number of rods ensured that the ball was launched consistently. If there was a slight misalignment between the rods,

then two guide rods would be more forgiving than four. Making sure that

the guide rods were perfectly parallel was a challenge we faced in the manufacturing process, but one advantage of having the pre-made holes in the aluminum stock is that it was easier to accurately locate the holes that our team drilled for the guide rods.

Located on each guide rod were polyurethane rubber tubes with a hardness of 40A. Their purpose was to soften the impact of the carriage on the frame. The rubber was chosen based on how much it is able to compress, and thus how much energy it is able to store. After

analyzing the effect of carriage impact forces on the rubber tube, it was found that a tube length of three inches would provide a sufficient distance for the carriage to decelerate safely. Eye hooks were fastened to the four top corners of the frame, as depicted in Figure 20, which were for attaching the elastic to the frame. The elastic selected was 3/8" OD and 1/8" ID, and would be formed into cords with bungee hooks on each end.

The four sides of the frame were walled with polycarbonate sheets to ensure that no participants could place their hands inside within the frame during use, avoiding injury. The sheets were bolted into the framing, and one of the sheets was hinged, acting as a door, which allows an assistant to reattach the winch cable to the carriage between shots.

Mounting of Frame to UPF

In order to mount the frame to the UPF, we had two steel hinges, two intermediate steel plates, and two square tubes with their bottoms cut off. While designing the mounting of this device, we decided that we wanted to make no modifications to the UPF. As a result, the hinges did not attach directly to the frame; instead we had steel spacer blocks for the hinges to bolt into. The spacer blocks were welded to the U-shaped square tubing, and that square tubing sat on the UPF directly, with holes for set screws to apply horizontal force to the UPF front bar.

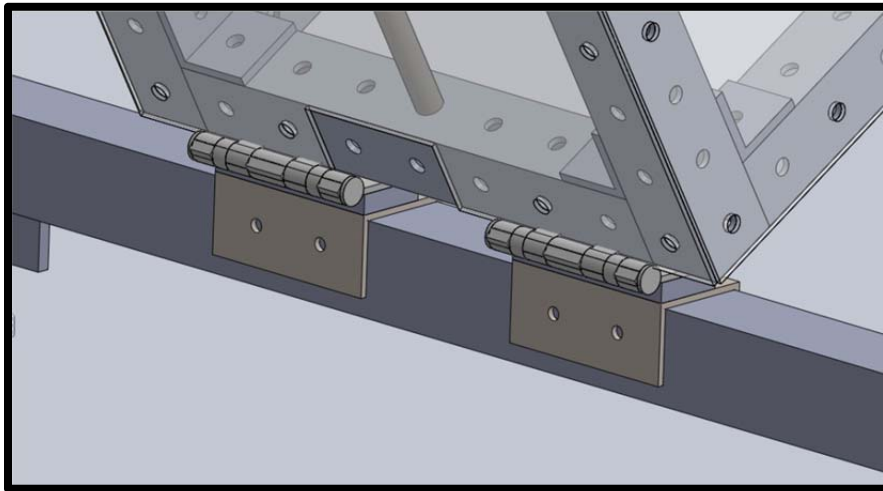

Figure 21. Frame attaching to the UPF by hinges.

Winch Shaft

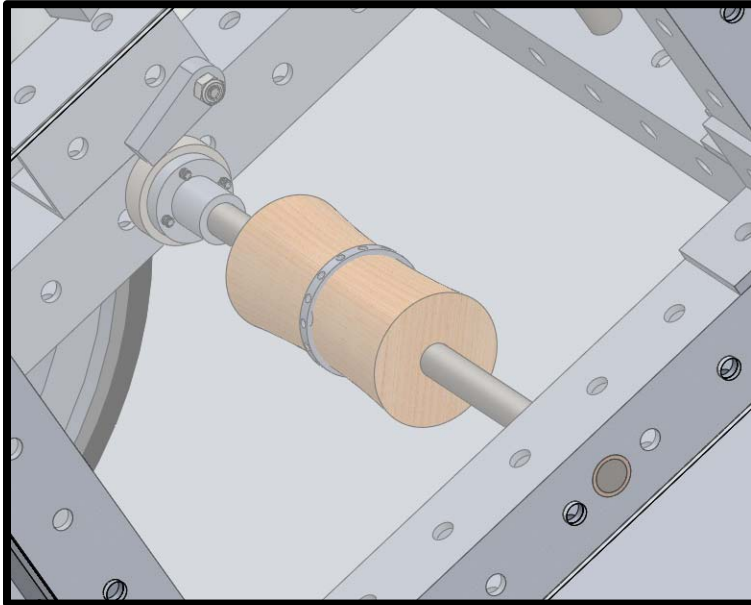

Figure 22. Winch shaft assembly, with ratchet and pawl.

The winch shaft bears the static load of 65 pounds, which exists when the elastic is fully stretched. It was 0.5" in diameter, and extended 13.5" all the way through both sides of the frame. The static force created a bending stress in the winch shaft, for which the shaft had a safety factor of 1.72. A spool made from a wooden cylinder was placed in the center of the shaft. The spool was drilled through, as well as the shaft, and the two were bolted together with a 1/4" diameter set screw. Nylon rope was to have been attached to this wooden cylinder by tightening a hose

clamp over both the spool and rope. The other end of the rope was attached to the quick-release bracket via a loop and rope stop. Holes were drilled in the frame to allow the winch shaft to fit, and it was supported by oil-impregnated bronze sleeve bearings on either side to allow for free spinning of the shaft.

Ratchet and Pawl

The ratchet and pawl allowed for the nylon to be rolled up various amounts without unrolling, and therefore the elastic to be stretched at discrete increments. Because the bore of the ratchet gear was larger than the shaft diameter, the ratchet gear was attached to the winch shaft by way of a flanged cylinder. The ratchet gear was fastened to the flange with set screws, and the cylinder portion was directly fastened to the winch shaft via another set screw. The pawl was positioned above the ratchet so that whenever it was displaced upward by the ratchet teeth, it would fall into place by way of gravity and without the use of a spring. Therefore, a mounting block for the pawl was installed into the frame, made out of the same aluminum stock as the rest of the frame.

Ratchet Arm Lever

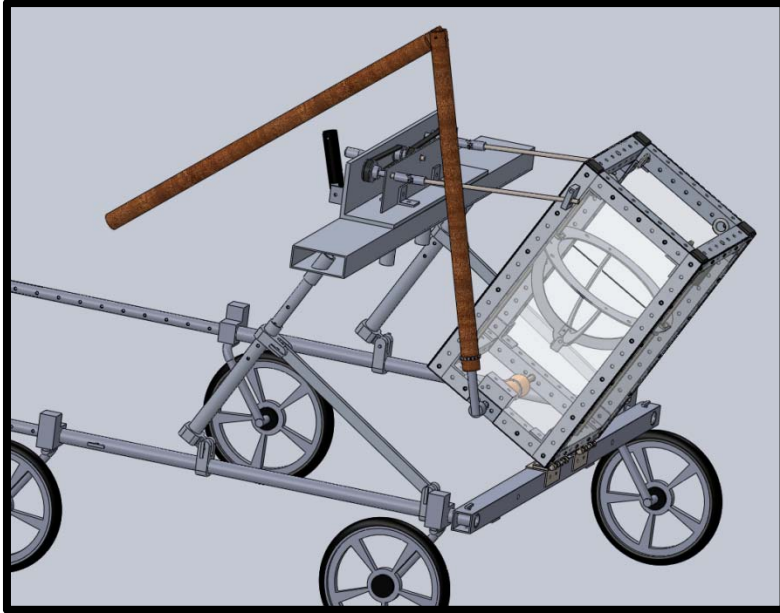

Figure 23. Ratchet arm lever extends from bottom of frame.

In order for the winch to spin, a ratchet arm lever was designed. Our lever was based off of the ratchet lever for the Friday Club's baseball-bat-swinging mechanism. The ratchet arm lever was composed of a standard ratchet wrench and two wooden dowels with a diameter of 1.5". The ratchet wrench fit into a hole located on the face of one of the dowels. The other end of the dowel had a clearance hole for a pin. This pin connected the two dowels together. This resulted in a jointed lever, which meant that the lever arm could be used from a

multitude of angles. A hex bolt was screwed into one side of the winch shaft and set in place with thread-locking adhesive. To ratchet back the carriage, we decided to place a 9/16" socket onto the end of the ratchet wrench and place onto the bolt threaded into the winch shaft. Then, cranking the lever back and forth would turn the winch shaft, winding the nylon rope around the shaft and pulling back the carriage. Because the shaft was jointed, the end could either be located near the user, so the user can crank the lever, but it could also be detached so that an assistant could ratchet from alongside the mechanism.

Carriage

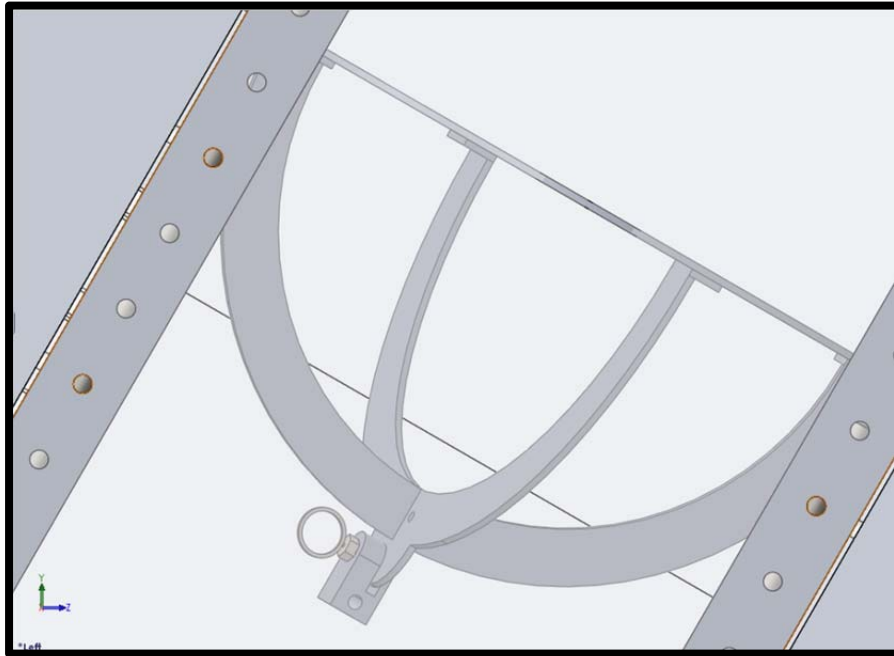

Figure 24. Carriage assembly.

The four carriage pieces were made out of 1/8-inch thick sheet aluminum. A light material such as aluminum was chosen in order to reduce the total amount of energy required to launch the basketball at the desirable speed of 30 ft/s. Aluminum was chosen over an even lighter material, such as plastic, because it needs to be able to withstand both the static force of the elastic in the fully stretched position, and the dynamic force at impact. In this design, we planned to bend the aluminum carriage pieces at 90 degree angle, creating surfaces to easily bolt the pieces together. Two flanged linear sleeve bearings were selected that allowed the carriage to roll along the guide rails with minimal friction, so that required launch energy was as low as possible.

Release Mechanism

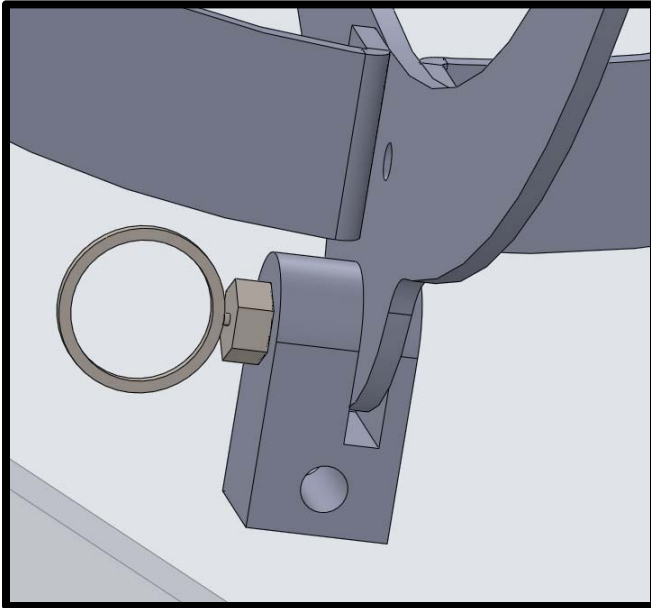

Figure 25. Release mechanism in the attached position.

The release mechanism consisted of a bracket with a spring plunger pin that ran through the carriage and to the other side of the bracket. The nylon crank-back rope was looped through the bottom hole of the bracket and pulled the entire carriage-release assembly back into firing position. At the time of our Conceptual Design Review, the leading idea for release the system was a dog clutch with a separating shaft. Since the dog clutch would require a significant amount of force to disengage, and the winch shaft would be left to spin at an uncontrolled speed, this idea was rejected in favor of a pin-release system

which was more easily controlled. To reduce the friction acting against the pull-pin, an oil-impregnated bronze sleeve bearing would have been inserted into both the carriage release hole and the bracket hole to reduce friction during pulling.

Safety Mechanism

The safety mechanism of this device made it harder to unintentionally disengage the launcher. From the pull-pin, a cable extended through a cut-out in the polycarbonate to a carabineer just outside of the cut-out where it was unable to slip inside of the frame. This carabineer allowed for the other side of the cable attaching to the user interface to be engaged only when the ball and carriage had been pulled back the desired distance and all participants and bystanders were clear of the launch path. The slots in the polycarbonate were incremented so that the cable was as close to in-line with the pull pin as possible, minimizing the required pull force.

User Interface

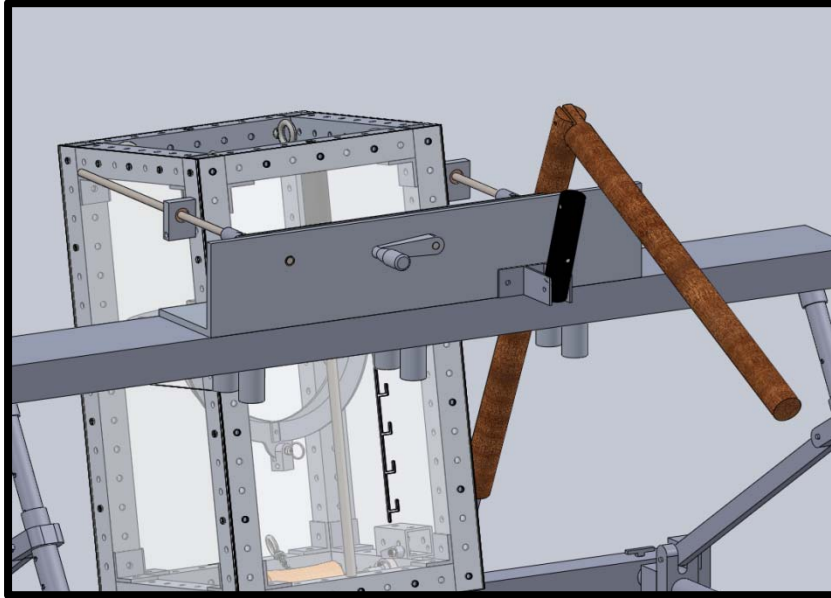

Figure 26. The user interface allows an athlete to have as much control of the system as possible from a wheelchair position.

For the user interface portion of our design, which sat on the table top of the UPF, we had a base made of angle stock aluminum with a second vertical fin which acted as a support bracket for the aiming mechanism. For the angle stock, we chose 3/8-inch-thick aluminum with five inch sides. The thickness was designed to provide a sufficient amount of stiffness when loaded to prevent significant bending. The width of the sides allowed us to utilize the majority of the UPF table top, giving greater stability and providing more space for other components to be mounted. In the initial design, six aluminum pegs were fastened to the angle stock by Tig welding. The pegs kept the angle stock centered and grounded with respect to the UPF. The crank handle was mounted in the center of the angle stock face to allow for easy use with either the left or right hand. To the right of the crank handle, the release lever was mounted using a long bracket with a pin for a pivot point. The lever had approximately two inches of clearance from the crank handle. We decided to mount the lever to the right rather than in the center to avoid interference with the crank handle. The ratchet arm lever was to be mounted to the right side of the device.

Aiming Assembly

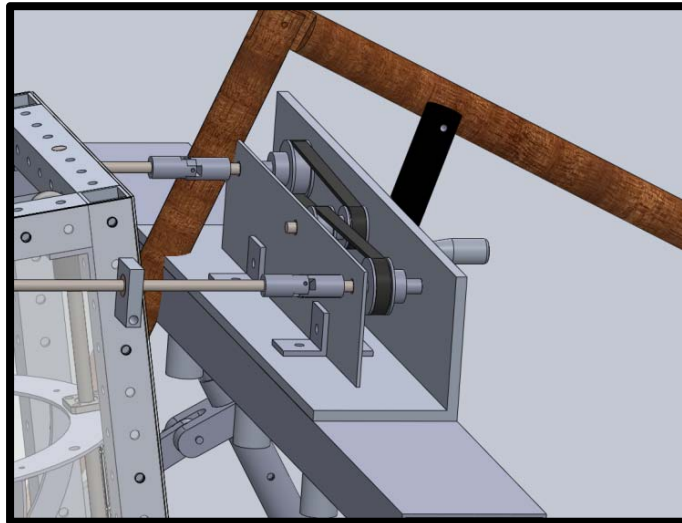

Figure 27. Working portion of tabletop mount showing support fin and aiming mechanism components.

All components of the aiming assembly were mounted on the same angle stock as the crank and release lever. The aiming assembly consisted of shafts and pulleys to translate rotational motion into an angle change, the crank handle to actuate the aiming mechanism, and a support plate. The shafts of the aiming mechanism needed to rotate, so to allow for smooth rotation we press fitted sleeve bearings into the face of the angle stock which reduced friction while still supporting a radial load.

The support plate is made of 1/8"-thick aluminum sheet and provided the rotating shafts of the aiming mechanism extra vertical support to prevent excessive deflection. Thin sleeve bearings were press fit into holes on this plate, allowing for low-friction rotation while still providing sufficient radial support. This plate was mounted to the angle stock aluminum mentioned above using four L-brackets fastened with nuts and bolts. This was designed to give the plate enough stability to not collapse during operation.

The rotating shafts of the aiming mechanism that fit through the angle stock and fin were to be made of 3/8"-diameter steel round stock. For these components, we needed a material with a greater stiffness than aluminum to prevent bending, and decided steel was the best choice since it is nearly three times as stiff as aluminum. There were three parallel shafts, one in the center of the angle stock face and one to each side of the central shaft. The central shaft had the crank handle bonded to one end and two 10-tooth timing pulleys mounted on the other end, held in place with set screws. Two timing belts connected the three shafts, transmitting the force applied on the crank handle equally to the outer shafts. The outer shafts had slightly larger (14-tooth) timing pulleys that were also held in place with set screws. The three pulley shafts transmitted the torque from the pulleys to adjoined lead screws in order to tilt the entire device. To prevent the shafts from sliding out of place and misaligning the timing belts, spacers were placed between the pulleys and two supports, restricting all shaft movement in the axial direction.

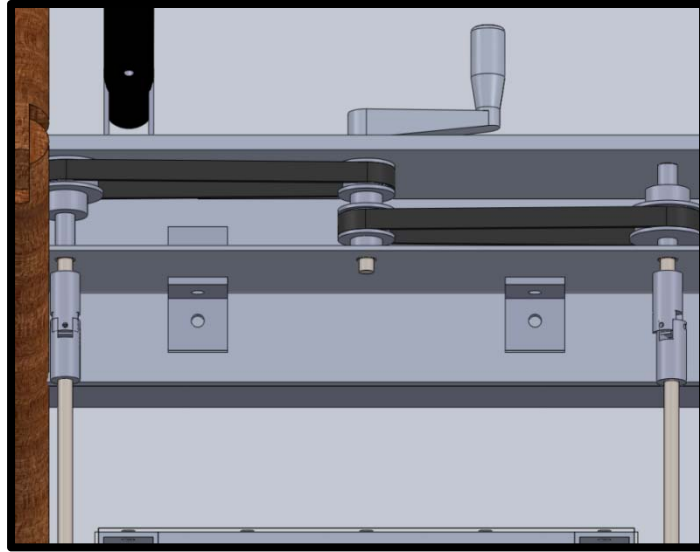

Figure 28. Pulley system for aiming mechanism.

The timing belts and pulleys chosen were designed to have no slip while being operated as well as to provide a small mechanical advantage for the user as they turn the crank handle. The pulleys on the central shaft were to have 10 teeth, and the outer pulleys have 14 teeth. With our orientation (small pulley to large) this would give a mechanical advantage of 1.4, meaning the user would only need to less force than if they were to directly turn the outer shafts.

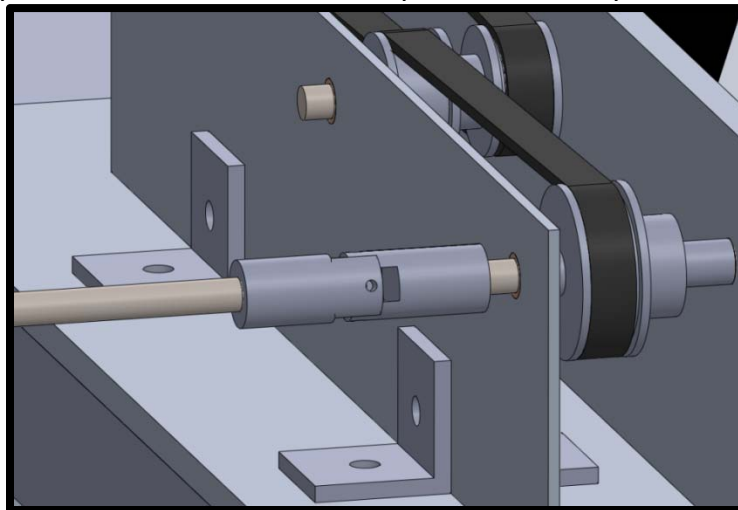

Figure 29. Universal joint that will allow for the transmission of torque to the lead screws of the aiming mechanism.

As the device changed angle, the angle of the lead screws need to change with it. Because of this, we need to be able to transmit the torque from the shafts at any angle. To do this we chose to purchase unbored universal joints to mount at the end of the outer shafts. Since they were unbored, we would machine one end to fit around the 3/8" shafts and the other end to fit the 1/4" lead screw tip, and then we would drill holes in each end to press spring-pins in so that the lead screws would transmit torque.

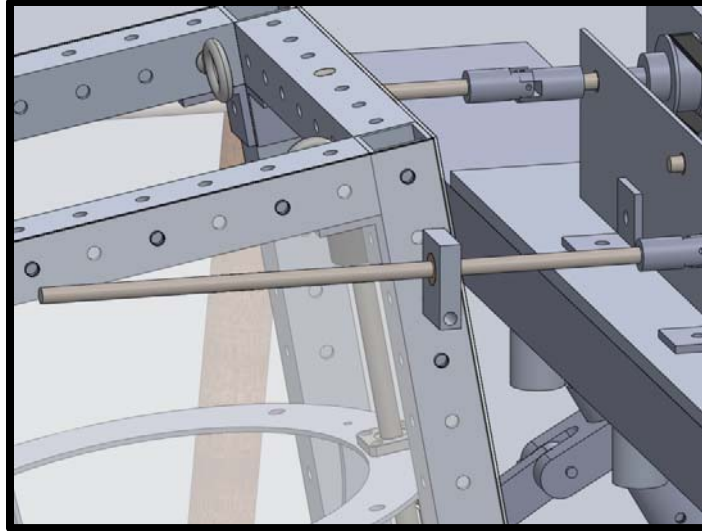

Figure 30. Lead screw of aiming mechanism which controls the tilt of the device.

The next component of the aiming mechanism was the ACME-threaded lead screws. These were what caused the firing angle to change. We chose an ACME-threaded lead screw rather than a standard threaded rod because AMCE threads had less friction. The only downside to using AMCE threaded parts was that we did not have the resources to tap ACME threads; therefore, we had to purchase ACME-compatible parts rather than manufacturing them ourselves. To attach the lead screws to the universal joint, we decided we would turn down a length of 5/8" of one end of the lead screw to 1/4" and would turn down the available end of the universal joint to be a 1/4" shaft (they would fit without needing to be press fit since machining a hole causes the hole to be either the nominal size or bigger, and the shaft would be either the nominal size or smaller). The other end of the lead screw ran through a cylindrical ACME nut, which was what moved up and down the length of the lead screw. To prevent the lead screws from falling out of the nuts or going too far through it, we secured a collar on each end of the lead screw.

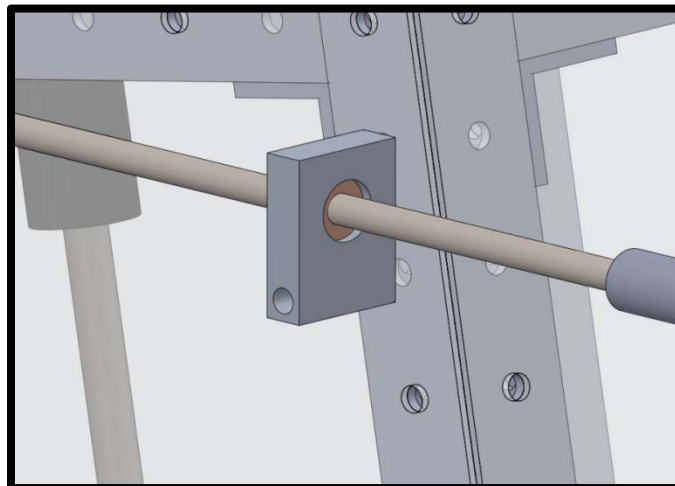

Figure 31. Custom bracket containing cylindrical nut to guide the lead screw as it is turned and allows the device to tilt.

The last components of the entire aiming mechanism were two custom brackets that we would machine ourselves. They were to be made from a one-foot-length piece of 6061 aluminum bar

stock that was 1" x 2". We would first cut off a 1/2" -thick section of the bar stock and drilled a hole with a 3/4"-inch diameter through the top half of the aluminum on the large face. The ACME nut would fit inside this hole and would be secured with set screws through the side of the aluminum bar. Then, on the longer side face of the piece of aluminum, we drilled another through-hole that had a diameter of 5/16". This hole was for the pivot point of the bracket. The pin that allowed for the pivoting was a long clevis pin with a removable pin to prevent the bracket from slipping off. This pin connected the bracket to the frame.

In order to make the process of attaching our device to the UPF easier, it could be completed in two steps. Prior to attachment the clevis pin for the lead screw hinge bracket would be removed, forming our device into two separate pieces—the frame and table top mount. The table top mount could first be installed by fitting the pegs into the holes on the UPF table top. Next, the frame could be set on top of the UPF bottom front bar. Then, the two assemblies could be attached by the clevis pins. Splitting the device in two for assembly and disassembly meant that the assistant did not have to lift more than 30 pounds at a time, meaning he could set up the UPF by himself in a timely manner.

Analysis Results

In order to design our device and to verify decisions that had already been made, we conducted analysis on various aspects of our design. First, we used projectile motion equations and experimental data to determine the appropriate angle of launch (61.4 degrees) and launch velocity of the ball (30.3 ft/s) that is required to make a 3-point shot. By combining that information with the kinetic energy required to accelerate the carriage to the same launch velocity and the potential energy required to increase the height of both the carriage and ball within the frame, the total energy that must be supplied by the elastic bands was determined to be 36.3 foot-pounds. Next our team purchased four sample elastic bands of varying inner and outer dimensions and performed force-displacement testing on each using a force gauge and ruler. From those results, we were able to determine the number of tubes necessary and stretched length required of each to store 36.3 foot-pounds of energy. We found that using four of the smallest bands (3/8 OD, 1/8 ID) would generate the necessary amount of energy when stretched three times longer than its unstretched length. The total force required to stretch these bands to that length was 65 pounds.

This value was the static loading on the winch shaft when the carriage was pulled back the maximum distance. From this information, we determined that a steel winch shaft needed a minimum diameter of 0.28 inches. As a result, we chose a winch shaft diameter of 0.5 inches, giving a safety factor of 1.782.

We also looked at the compressive forces on the guide rods to make sure that buckling was not a concern. For this calculation, we assumed a worst-case scenario: that the frame was not supporting any of the static load so the guide rods were taking all 65 pounds (or 32.5 pounds each). Approximating each guide rod as a fixed-fixed beam, and assuming the guide rod is made from 1/2-inch-diameter steel, a guide rod would not buckle unless it experienced a force of 6370 pounds. This gives the guide rods a safety factor of 196.

After proving the validity of our design under static loading, we conducted an analysis during impact loading. The impact force was caused by the carriage colliding with the top bars of the frame. In order to determine a plausible impact analysis we used known data from the rubber stoppers we plan to use. By estimating the stiffness the polyurethane rubber and the length and cross-sectional area of the stopper, we were able to use mechanics of materials to solve for the force per displacement, also known as spring constant k . With this information, we were able to use the known energy stored in the system to solve for the distance that the rubber stopper will be displaced. With this displacement and the spring constant, Hooke's law was used to estimate an impact force. Using this method, the total impact force was found to equal 226 pounds.

A free-body diagram of the frame was made at impact, and forces on the lead screw and hinge were determined. Each hinge was found to experience a load of 136 pounds and each lead screw felt a tensile load of 18.8 pounds. Each hinge was rated for a 100 pound load and surely had a factor of safety greater than 1, so we were confident that our hinges would support the frame without issue. Tensile stress calculations were completed on the lead screws to determine the sizing of them. Comparing our lead screw size to the minimum size needed for our purpose, we had a factor of safety of 23.3.

Additionally, press fit calculations were conducted for the four assemblies that will be attached via interference fit—pulley bearing to angle stock, ACME cylinder nut to lead screw hinge bracket, winch shaft bearing to frame, and crank to crankshaft. All interior, "shaft" parts were purchased and, because they were intended to be press fitted, were designed to be slightly larger than their nominal outer diameter. Therefore, we only needed to worry about hole sizing. For each press fit, we found that each hole could not have been smaller than the nominal diameter, and could only have been 0.001 inch larger. These holes had the tightest tolerance of any part of our design. For a more detailed look at these calculations listed in this section, see Appendix C.

Cost Analysis

As parts were selected and designed for our project, our team kept a running tally of all materials to be purchased and their online purchasing price. Once all parts had been designed and integrated into our final design, a full Bill of Materials was constructed, listing every named part, part description, vendor, part number, and cost. This was updated throughout the manufacturing phase whenever our design changed. The final in-depth Bill of Materials for necessary parts can be found in Appendix B. A summary of all costs is detailed in Table 2.

Table 2. Abbreviated Bill of Materials

	Part	Stock Description	Cost
Stock Material and Labor	Frame	Aluminum Bolt-Together Framing	\$ 122.20
	Carriage	6061 Aluminum Sheet	\$ 52.92
	Carriage	WaterJet Cutting Services	\$ 86.00
	Table Top Pegs	6061 Aluminum Round Stock	\$ 20.89
	Lead Screw Hinge	6061 Aluminum Bar	\$ 8.76
	Table Top Base	6061 Aluminum Angle	\$ 57.18
	Base Hinge	Low-Carbon Steel Rectangular Bar	\$ 4.07
	Base Hinge	A500 Steel Structural Square Tube	\$ 10.12
	Pulley Shafts	1144 Medium Carbon Steel Rod	\$ 21.70
	Ratchet Flange	1144 Medium Carbon Steel Rod	\$ 15.26
	Guide Rods	303 Stainless Steel Precision Shafting	\$ 28.00
	Winch Shaft	303 Stainless Steel Precision Shafting	\$ 14.00
	Elastic Tubing	Latex Tubing	\$ 12.25
	Rubber Stoppers	Polyurethane Rubber Tube	\$ 16.02
	Wooden Spool	Red Oak Dowel Rod	\$ 6.84
	Ratchet Arm	Oak Dowel Rod	\$ 26.44
	Release Lever	Delrin [®] Acetal Resin Rod	\$ 7.37
	Spacers	Delrin [®] Acetal Resin Rod	\$ 11.55
	Safety Casing	Impact-Resistant Polycarbonate Sheet	\$ 43.96
Off-the-Shelf Parts	Frame Accessories	-	\$ 160.15
	Fasteners	-	\$ 203.46
	Bearings	-	\$ 74.43
	Gears, Pulleys, and Belts	-	\$ 190.89
	Add'l Ratchet Arm Parts	-	\$ 26.28
	Add'l Aiming Mech. Parts	-	\$ 152.01
	Add'l Release Mech. Parts	-	\$ 61.12
	Spare Parts and Materials	-	\$ 334.03
	Total Cost		\$ 1,767.90

From this Bill of Materials, the total cost of our project was a little over \$1,750 which placed us about \$250 over our supplied budget of \$1,500. Our project went over budget due to a handful of small manufacturing mistakes and design changes. For example, we broke a universal joint while boring a hole in it, and it cost about \$50 to purchase a new one. If we were to make another basketball shooter with the exact same design as our final prototype and made no mistakes during manufacturing, the device would only cost about \$1,400 to make, which is under budget.

Safety Considerations

Because this device will be operated in close proximity to a large number of people, it is important that our device is inherently safe. While there are many moving parts within the frame and aiming assembly that could cause pinch points, these regions will be covered with polycarbonate sheets, allowing users to see the mechanical workings of our launcher without the risk of being harmed by it. Any edge on our device will be filed down or rounded, ensuring that no user can be injured by sharp edges.

Because our device contains no electrical components, there is no risk that electrical systems are not properly grounded or that large electrical voltages will exist. There are no explosive gases or flammable liquids in our design, and no materials known to be hazardous to humans.

To ensure that our device does not generate high levels of noise upon impact, rubber stoppers are installed at the top of each guide rod. As the carriage impacts these stoppers, the rubber will compress and remove energy from the carriage, bringing it to a stop more gradually than if it were to hit the metal frame directly. The rubber stopper's cushioning effect should reduce the impact noise to levels that will not frighten the user or damage the user's hearing.

While the system does contain stored energy in the form of elastic tubing and the system does produce a projectile, our team has designed a safety mechanism to reduce the risk of accidental firing. The release cable will be two cables joined by a carabineer-hook system. Prior to stretching the elastic bands, the carabineer will be disengaged from the hook, separating the pull pin from the user's release lever. This means that the user cannot release the mechanism in its current state. Once the ball has been loaded and pulled back to its intended distance, the assistant will confirm that the launch path of the ball is clear before reconnecting the carabineer to the hook, rendering the release lever live. The user can then pull the release lever, shooting the ball. During reset of the pull pin, the assistant will unhook the carabineer again.

Due to these safety considerations, we felt it would be a good idea to write an operation and safety manual for any helpers who will be setting up and overseeing the use of our device. The safety manual can be found in Appendix F.

Repair Considerations

Of all parts on this device, we anticipate that the latex tubing will be the first parts to require replacement. After a certain number of stretches, the latex tubing will begin to plastically deform and may not provide enough energy over time. To plan for this, we have designed the latex tubing to be easily changed out for new tubing. The tubing lengths are made by first cutting an appropriate length of tube and knotting each end. Bungee hooks are then fastened onto each end. To install on the device, one end is hooked onto the carriage and the other is hooked onto an eyebolt at the top of the frame. This design makes the tubing lengths easy to manufacture, install, and replace.

We could also anticipate that the nylon rope used to pull back the carriage could be worn down over time. To replace this, a person could cut or untie the rope from the carriage end, loosen the hose clamp on the spool, and remove the rope from that end. The rope will now be unattached and can be removed. A similar length of rope can be cut and installed in the same manner. We anticipate that this replacement can be done in less than ten minutes.

While we do not anticipate any other parts wearing out within two years, we have designed our device with ease of manufacturing in mind. Because none of our team members are very experienced welders, a majority of components are assembled using nuts and bolts. This means that nearly all parts can be assembled and removed with basic tools, so it should not be too difficult for the device to be serviced. Many of the parts on our device are off-the-shelf parts, so if those parts wear out, no manufacturing should be necessary. A replacement part can be bought and installed instead.

Product Realization

After completing our detailed design, the next step was to manufacture all parts and assemble them into a prototype. In order to reduce production time, commercial-off-the-shelf parts were used as much as possible. However, modifications had to be made to many of these commercially-bought parts, and many custom parts had to be produced as well. Manufacturing this device was a challenging feat that took twelve weeks and over 300 man-hours of work.

Frame

The frame was cut from aluminum square tubing with predrilled-holes on the chop saw, and was deburred. Four long members and eight short members were cut to size. The only other modifications to this frame were holes for various attachments, such as the holes to the winch shaft, the guide rods and the mounting hinges. L-brackets were purchased for attaching the frame together with bolts. The bronze sleeve bearings for the winch shaft were inserted into their holes with an arbor press. The guide rods were 1/2" stainless-steel rods and had holes drilled at each end in order to position them straightly and securely into the frame. Because we feared that the basketball may hit the protruding bolt heads attaching the guide rods to the top of the frame, the flathead bolts were used, and the pertinent holes in the frame were countersunk so that the top of the bolts would lie flush against the frame.



Figure 32. In order to drill precise holes in our frame members, the mill was used.



Figure 33. All short frame members cut to length with holes drilled.

Bottom Hinges



Figure 34. The steel rectangle was Mig welded to the custom u-channel.

the welds, holes were drilled and tapped into the part and the hinges were bolted onto it. The other end of each hinge was bolted onto a frame member, through specially-drilled holes.

The bottom UPF attachment point was made from steel square tubing. To create u-channel with straight walls, one face of the square tubing was cut off using the chop saw, and the resulting u-channel was ground to remove sharp edges. Because the off-the-shelf hinges were made of an unknown material, they could not be welded to the u-channel; instead they would have to be held on with fasteners. However, the u-channel was too thin to be threaded so a rectangular piece of steel was Mig welded to the u-channel. After grinding down

the welds, holes were drilled and tapped into the part and the hinges were bolted onto it. The other end of each hinge was bolted onto a frame member, through specially-drilled holes.

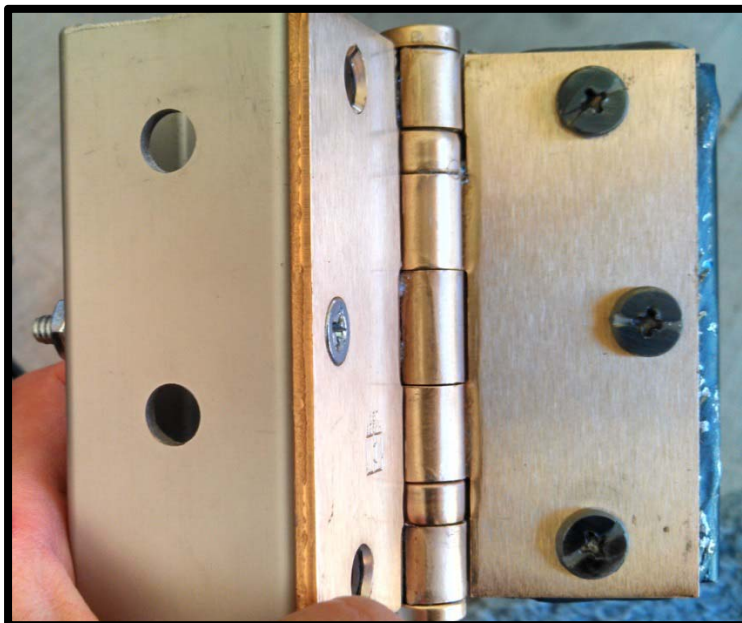

Figure 35. The bottom hinge assembled to both the frame and the u-channel.

Winch Shaft and Components

The winch shaft was cut to length and two setscrew holes were drilled into it and tapped. One hole would locate the spool, while the other would locate the ratchet flange. On one end of the winch shaft a hole was drilled and tapped. Into this hole, a custom bolt with a long head was made to act as an interface between the winch shaft and ratchet arm. The bolt was made from a piece of steel hex stock, with one end turned down to 5/16". This round portion was threaded to create a 5/16-24 bolt.

The ratchet flange, which adapts the off-the-shelf ratchet gear to fit on the winch shaft, was machined from a 1" diameter carbon steel stock metal cylinder on a lathe, and then turned down on one end to 3/4" diameter, and drilled through at 1/2" diameter. Holes were drilled and tapped into the face of the ratchet flange to fasten the ratchet via set screws, and another hole was drilled and tapped into the body of the flange for a set screw to locate the



Figure 36. The ratchet flange attaches to the winch shaft via a set screw.

flange on the winch shaft. The holes on ratchet gear and its flange needed to be drilled on a mill



Figure 37. To attach the ratchet gear to its flange, four holes were milled and threaded.

in order to locate them precisely enough. Through trial and error, we found that the holes had to be tapped with the two parts clamped together, so that the threads would line up correctly. To prevent the sharp steel ratchet from wearing down the adjacent aluminum frame, a space made from Delrin was lathed to serve as a barrier between the ratchet gear and frame, while also restricting axial motion of the winch shaft

The spool was cut to length on a band saw from a 2" diameter, 4" long wooden cylinder, and was sanded on a spindle sander to achieve a tapered diameter. A 1/2" hole was drilled all the way through the spool for the winch shaft, and two 1/4" holes were drilled in through the radial direction of the spool. One, through the center, allowed a set screw to lock the spool on to the shaft both axially and rotationally. The second hole was where the winch rope was secured to the spool.

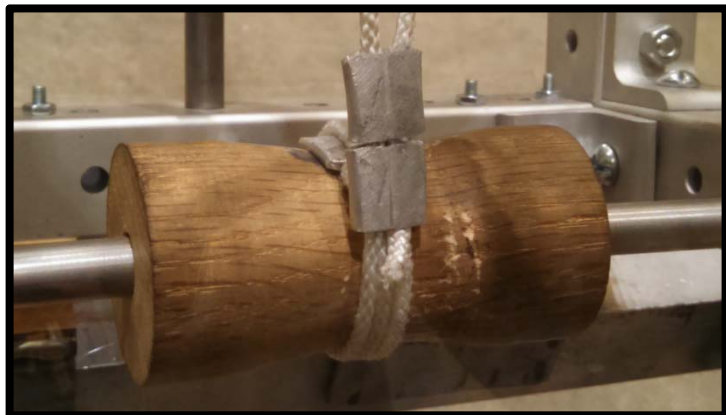

Figure 38. The spool attaches to the winch shaft via a set screw. The winch rope is secured around the spool through another hole.

Pawl Block

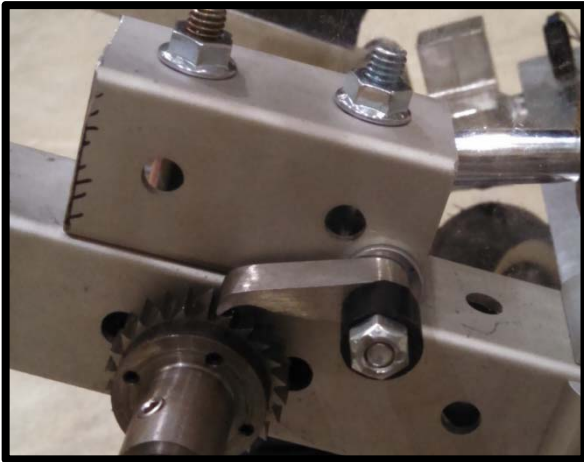

Figure 39. The pawl block assembly mounts two a frame member with two long bolts.

The pawl block was cut from the same stock as the aluminum frame. An extra hole was drilled on a mill, because the exact location of the hole was very important; the pawl would interlock with the ratchet gear most effectively when the centers of the two parts are $1 \frac{5}{16}$ " apart. A long bolt was installed through this hole, and acted as the shaft for the pawl. Because the bolt was slightly long, a Delrin spacer was machined on a lathe to use up the remaining length of the pawl shaft. This prevented the pawl from sliding back and forth along its shaft. The entire pawl block assembly was attached to the frame with long bolts put through the pre-drilled frame holes.

Table Top

The table top was made from aluminum angle stock measuring $5'' \times 5'' \times \frac{3}{8}''$ thick. Numerous holes were milled in this angle stock for various parts. On the vertical side of the angle stock, three holes were drilled and bronze sleeve bearings for the pulley shafts were pressed in. Two smaller holes were drilled, allowing the bracket for the release lever to be bolted on. Another $\frac{1}{2}''$ hole was drilled for release cable guiding. On the base of the angle stock, ten clearance holes for $5/16$ - 18 bolts were drilled. Four of these were for L-Brackets that hold up the support plate, whose process is covered below. The other six were for the table top pegs. While the design initially called for the table top pegs to be TIG welded to the table top, we decided that bolting the pegs on would allow for more precise alignment. The table top pegs were machined on a lathe from $1 \frac{1}{4}''$ 6061 aluminum stock. In one end, a hole was drilled and tapped for the bolt connecting it to the angle stock. On the other end, a large amount of material was bored out to lighten the pegs. When we first tried to fit the table top assembly into the UPF, we found that the peg diameter was slightly too large. As a result, we turned down each peg slightly to allow for a clearance fit into the UPF.

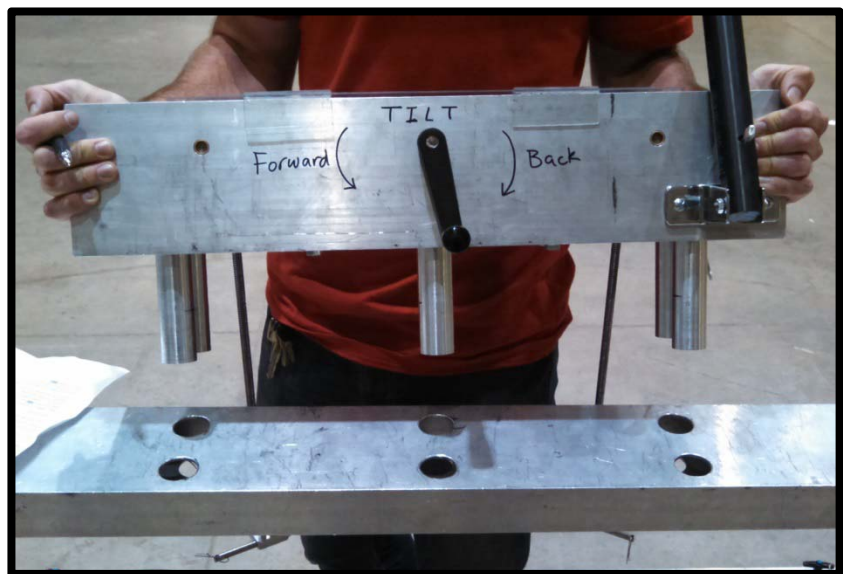

Figure 40. The table top assembly, with the pegs attached to the angle stock, is shown. The assembly fits into the holes shown in the UPF.

Support Plate

The overall shape of the support plate was cut on the band saw from 1/8" thick sheet aluminum. In the mill, holes were drilled and bronze sleeve bearings were pressed into them. Because the bearings were thicker than the support plate, the protruding parts of the bearings were sanded off. The support plate was attached to the table top with the same L-brackets used to hold the frame together.

Carriage

The carriage parts are all made from 1/8" thick aluminum sheet. The cutting of these four parts was outsourced to Central Coast Creative Cutting and was waterjet cut. Initially, our team had



Figure 41. The carriage pieces were cut and bolted together with L-brackets

planned to bend the ends of these pieces to 90-degree angles and then bolt the four pieces together. However, after bending spare aluminum strips it became apparent that 6061 aluminum was too brittle and would snap rather than bend. Our solution was to cut off the material that would have been bent, and replaced them with small off-the-shelf L-brackets. To use this solution, new holes had to be drilled in each of the three support members.

While the holes in the top plate

were sufficient, we found that the carriage was slightly too large and would rub against the plastic casing on the frame. To fix this, the sides of the top plate were sanded flat in the four places that it could hit the plastic casing. The four pieces were bolted together and secured with thread-locking glue. Linear slide bearings, bought off-the-shelf, were installed in two places in the carriage to ensure that the carriage slides smoothly along the guide rods.

U-Joints, Lead Screws, and Lead Screw Hinge



Figure 42. U-joints attached to the pulley shafts, and the lead screws above them

Two machinable U-joints were bought for joining the pulley shafts to the lead screws. A $3/8$ " diameter, $5/16$ " deep hole was drilled in one end of a U-joint for the pulley shaft to be inserted. A $1/4$ " diameter, $5/16$ " deep hole was drilled in the other end to insert the turned-down lead screw.

These holes were bored out on a lathe to ensure they were centered

on the U-joints axis. The lead screw needed to be turned down to the aforementioned $1/4$ " diameter on one end for a length of $5/16$ " so that it would fit in the U-joint which was also done on a lathe. The pulley shaft was inserted into the U-joint to drill a $1/16$ " through hole for a spring pin to be inserted by means of a press fit which fixed the two components together during rotation. This was repeated for the lead screw end of the U-joint.

The lead screw hinge was made out of a 2 "x 1.5 "x 0.5 " block of aluminum, which was cut out on



Figure 43. Lead screw hinges with the ACME nut imbedded

the horizontal band saw and then the $3/4$ " hole for the cylindrical $3/8$ "-12 ACME nut was drilled on a mill to ensure it was centered on the face of the hinge. A $5/16$ " hole was drilled through the bottom of the hinge, perpendicular to the hole for the cylindrical nut, for a clevis pin that attaches the hinge to the frame.

This pin allows the hinge to pivot freely as the frame tilts forward and back. A $1/4$ "-20 hole was drilled and tapped in the top and side of this hinge, perpendicular to the hole for the

cylindrical nut, so that set screws could be used to

fasten the ACME nut inside of the hinge. One

hinge was made for each lead screw.

Safety Casing

Two $1/16$ " thick, 2 'x 3 ' sheets of polycarbonate were bought and cut into five separate panels to make up our safety casing. Three of those panels were cut to be 13.5 "x 24 " , one of which had some slots milled onto it for our release cable. This panel, which faces the user, has a series of slots so that the release cable can be adjusted to different heights as the carriage is pulled back

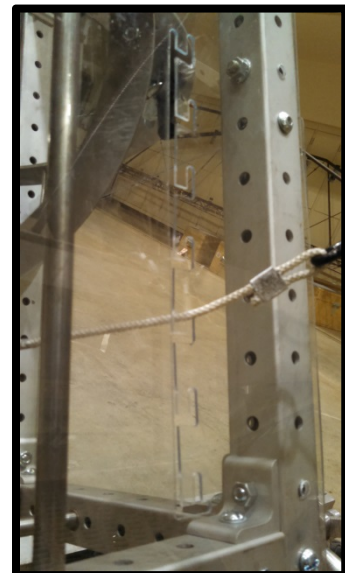

Figure 44. Back safety casing with the release cable slots

different distances. By having the slots, we were able to keep the release cable pulling directly in line with the quick release, spring-loaded pin, thus reducing the force necessary to pull the pin out. The other two panels were cut to be 13.5"x 12", one of which was made to be our access door. Using a standard bolt latch, the access door allows an assistant to easily adjust and reset the launcher or safely release a misfire. The polycarbonate sheets had several 5/16" holes drilled through them in order to fix the sheets to the frame using 5/16"-18 bolts and nuts. This casing prevents any potentially harmful, fast moving parts from failing and hitting anyone in the vicinity as well as stopping people from sticking their hands into the device.

Release Bracket

Our release bracket was made from a piece of 3/4" square, 6061 aluminum bar stock. It was first cut on the cutoff saw to a length of approximately 1.5". It was then taken to a mill to first have both ends faced to ensure all faces were parallel or perpendicular. Once the piece of aluminum was faced to size, a 5/16" through-hole was drilled 3/8" from the long edge and 1.25" from one of the short ends. This hole was then tapped to



Figure 45. Release bracket, freshly milled and tapped, with the pull pin installed.

have 3/8"-16 threads so that our spring-loaded quick release pin could be inserted. The ring on the quick release pin is welded so that it does not come apart when it is pulled for launch. Then a 1/4" diameter through-hole was drilled, perpendicular to the tapped hole, 3/8" from a long edge of the bracket, and 3/8" from the same short edge as the tapped hole. This hole was for the rope to connect the release bracket to the winch shaft spool. After the holes were made, a 7/8" deep slot was made perpendicular to the tapped hole using the edge closest to the tapped hole as the open end of the slot. This slot, rather than being centered, was 0.22" from a long edge of the bracket. This slot is meant to fit a piece of the carriage in it and therefore must be at least 1/8" wide, so a 1/8" or 3/16" end mill is sufficient for the job. Either can be used as one will not diminish or limit the functionality of the bracket or the release pin. A 3/16" end mill was used for the release bracket currently in use.

Cable and Rope Attachments

The release lever is a 1' long Delrin cylinder, which has one end machined flat on both sides on a mill and a hole drilled through it for the pivot on the table top. A hole is drilled through 2" above this pivot for the release cable to go through. From the release lever to the release bracket, there is a steel cable with a cable stop at one end to keep it slipping through the lever, which runs through the table top and is looped with a cable ferrule and a rubber end cap to keep it from fraying. This loop stops just short of the safety casing, where it connects to a carabineer tied to a nylon rope which runs to the welded ring on the release pin, looped around this with a ferrule. Another nylon rope segment loops through the release bracket bottom hole with a ferrule, extends down to the spool and loops through a hole in the spool which was hand drilled, and secured in place with a ferrule as well. An extra ferrule was included on the release bracket end of the nylon rope to hold it more securely, as this rope undergoes significant tension.

Changes Made During Manufacture

Throughout the manufacturing process, we realized that parts of our design were insufficient for a successful prototype. As a result, we made many changes to the design of our final prototype. These changes are shown in the drawing packet, found in Appendix E. A description of all changes can be found below.

Stronger Elastic

We had calculated early on that four single bands of elastic tubing with an ID of 1/8" and an OD of 3/8" would be sufficient to launch the basketball from the three point arc, but this was not the case. We tried doubling the elastic and it still wasn't enough. At that point, however, the bungee hooks were failing; the wire clips couldn't take the load without slipping out of the bungee hooks. This required a new method to secure the elastic. We decided wire cable clamps could provide enough holding force and also made the elastic more readily adjustable and removable. To get enough power we had to step up our elastic from the size mentioned before to have an ID of 1/8" and an OD of 1/2". This provided us with enough power to make a basket from the three point line.

Carriage Bending

Our carriage was cut with a water jet and made of 1/8" thick 6061 aluminum. Our design required the vertically oriented members to be bent 90° at the ends, but 6061 aluminum is too brittle for that and breaks. We decided to grind down the ends and use small L-brackets to connect the carriage together.

Carriage Top Plate

The top plate of the carriage was originally supposed to be completely round, but as we put on the safety casing, we found that the top plate interfered with the polycarbonate. To mitigate this problem we ground down the problem areas to a flat edge to have some clearance between the carriage and the safety casing. We also changed the method used to connect the elastic tubing to the carriage which eliminated the need for bungee hooks. Instead, we drilled two 1/2" holes through the top plate so that we could fit our new, larger elastic through them and use our wire cable clamps to secure the elastic to the carriage.

Release Bearings

We planned on press fitting a sleeve bearing into the release bracket and the hole in the carriage for the release pin in order to reduce the friction on the release pin, thus reducing the activation force. However, we found that the bearings actually increased the friction because there was not enough clearance between the bearings and the pin. We left out both bearings which made the activation force more reasonable.

Release-Pin Ring

During initial testing of our device, we found that the key-ring that attached the pull pin to the release cable was not meant to handle the force required to pull the pin from the release bracket. As a result, when the release cable was fully-loaded, the release-pin unwound. This meant the release cable was no longer connected to the pull pin and the device could not be

shot. To fix this solution, we used a Mig welder to tack the two ends of a new ring coil together. This prevented the ring from unfolding in future launches.

Spool Hose Clamp

At first we wanted to use a hose clamp on the spool to secure the rope to it, but we found that the rope was rubbing against the worm on the hose clamp which was causing the rope to fray. To prevent the rope from fraying and snapping, we drilled an off-center hole in the spool big enough for the rope to fit through. We fed the rope through this hole and through a loop of the rope to secure the rope to the spool. The loop of rope will not come loose as it is clamped by a ferrule, a metal sleeve you flatten over the rope to hold it in place.

Location of Ratchet Arm/Winch Shaft Parts

We originally had the ratchet arm on the same side as the release lever, but they interfered with each other. We had to move the release lever farther outward because a person's hand would have hit it while using the crank handle if it were placed in the original location. Flipping the winch shaft and having the ratchet arm on the left was an easy solution to prevent interactive parts from being too confined.

Hex Bolt

In order to crank back the carriage, we intended to use a standard 5/16-24 hex bolt with our socket wrench ratchet arm. We found that the socket was unstable as it rested on the head of the bolt, so we manufactured our own hex bolt with a 1" long head. This extra length made the ratchet arm far more stable while cranking the carriage back.

Winch Shaft Hole for Ratchet Flange

In our first design, we planned to secure the ratchet flange to the winch shaft by a set screw. There was initially no corresponding hole in the winch shaft, and the rigidity of the flange depended on the force between the tightened set screw and the winch shaft. However, due to the high torsion loads on the ratchet gear, and therefore on the flange, we decided we would feel more comfortable having the set screw thread through the winch shaft.

Pawl Block Shaft

Originally, the shaft for the pawl was designed to be a shoulder screw that runs through one side of the pawl block. We encountered two problems with this. First, because the shaft was only supported by one side of the pawl block, it was inherently unstable. Second, the shoulder screw we ordered was too large for the pawl. Instead of ordering an appropriately-sized shoulder screw from McMaster Carr and waiting for it to arrive, we opted to go to a local hardware store and purchase a long 1/4-20 bolt with a long unthreaded portion. This bolt was long ago to run through both sides of the pawl block, and the pawl was able to rotate freely on the unthreaded portion.

ACME Cylindrical Nut Assembly

Initially, we planned to press fit our cylindrical ACME nuts into the lead screw hinges. However, the hole we drilled ended up just too large for a press fit. Instead, we used set screws to hold the cylindrical nuts into the lead screw hinges.

Clevis Pin Length

For our lead screw hinges we initially had 1.75" clevis pins because we didn't intend on putting the pins through the entire frame, only one wall. We later discussed that the pins would be too unstable like that, so we purchased 3.5" long clevis pins so that they would have two support points from the frame rather than one.

Pulley Sizes and Belts

For the aiming mechanism we planned on using four pulleys; two with 10 teeth in the center, and two with 14 teeth, one on either side. However, our 20.2" belt was too big and would slip during operation, so we ordered a new 19.5" belt. This new belt was too small, so we had to order two pulleys with 12 teeth. Our final orientation was with two 10-tooth pulleys in the middle, a 12-tooth pulley on either side of the small pulleys and the 19.5" belt.

Table Top Pegs

We were going to weld the table top pegs to the angle stock, but we were concerned about how straight the pegs would be after welding. Instead we drilled and tapped 5/16-18 holes in one end of the pegs to secure them to the angle stock. We bored out the other end in an attempt to reduce the total weight of the aiming mechanism.

Eye Strap

To route the release cable to the release lever, we initially planned to use a brass tube to guide the cable, but securing the brass tube to the angle stock seemed problematic. Instead we used an eye stop which we screwed into the angle stock to secure it in place. The eye stop provides a curved surface for the cable to slide over and also feeds the cable directly to the release lever, preventing it from being pulled to the side at some angle.

Release Lever Length

Initially, the release lever was designed to be six inches long. This was because we had planned to secure the release cable two inches from the lever's pivot, and a 3 to 1 mechanical advantage was calculated as sufficient to lower the required force to 5 pounds. However, the shortest length of the material we wanted was one foot. We decided to use the whole length because there seemed to be no downside to improving the user's mechanical advantage. This later proved to be a necessary change, because the frictional force generated when thicker elastic was employed was much greater than before.

U-Channel Set Screws

We thought about drilling and tapping some holes in the vertical faces of the hinges that mount onto the UPF, but the material is not thick enough to have the minimum three threads active.

We decided to forgo using any fasteners on the hinges and have it resting on the UPF front member.

Countersunk Screws

When shooting the ball, we found that the ball often hit the head of the bolt that went through the guide rod causing it to not properly fire. To reduce the profile of this bolt, we replaced it with a flat head bolt and added a countersink to the inside hole so that the bolt would be flush with the frame member. This allowed the basketball to be shot without any interference from the bolt.

Design Verification

There were numerous design requirements that needed to be tested, some quantitatively and others qualitatively. A summary of the results is found in Table 3 below. Acceptance criteria are defined by the same method as our design specifications: Inspection (I), Analysis (A), Test (T), and Similarity to Existing Designs (S). For all tests, the test stage is DV, which stands for design verification.

Table 3. Design verification table, listing testing of all components and mechanisms.

Item No	Specification	Test Description	Acceptance Criteria	Test Responsibility	Test Stage	SAMPLES		TIMING		TEST RESULTS		
						Quantity	Type	Start date	Finish date	Test Result	Quantity Pass	Quantity Fail
1	Activation Force	Force Gage	T	Ricky	DV	5	B	6/2/2014	6/2/2014	20 lbs avg	0	5
2	Weight	Scale	T	Brett	DV	1	B	5/29/2014	5/29/2014	27.2 lbs, 15.6 lbs	1	0
3	Storage Space	Place on Storage Cart	I	Ricky	DV	1	B	5/30/2014	5/30/2014	Fits	1	0
4	Set-up Time	Set up Device	I, T	Brett	DV	3	B	5/26/2014	5/26/2014	3:17 mins max time	3	0
5	Reset Time	Reset Device	I, T	Brett	DV	4	B	5/26/2014	5/26/2014	30s avg	3	1
6	Shooting Range	Shoot Device	A, T	Ricky	DV	4	B	5/24/2014	6/3/2014	20.78 ft*	0	4
7	Angle of Motion	Move Frame with Aiming System	I	Brett	DV	1	B	5/23/2014	5/23/2014	60°	1	0
8	Guide Rails Parallel	Run Carriage Along Rails	I, T	Brett	DV	1	B	5/8/2014	5/8/2014	Smooth travel	1	0
9	Winch Shaft Deflection	Fully Load Shaft	A, I	Brett	DV	1	B	5/24/2014	6/3/2014	No visible deflection	1	0
10	Rope Strength	Fully Load Rope	I	Brett	DV	5	B	5/24/2014	6/3/2014	Intact	5	0
11	Elastic Durability	Fully Load Elastic	A, I	Brett	DV	5	B	5/24/2014	6/3/2014	Intact	5	0
12	Elastic Stationary	Fully Load Elastic and Shoot Device	I	Brett	DV	5	B	5/24/2014	6/3/2014	Intact	5	0

The first test on this list is the actuation force test. At the full strength of the launcher, the lever was pulled with the force gauge on it in order to measure the force it takes to pull the quick-release. The average force to activate was 20 pounds, which is well over the 5-pound maximum set by our team earlier in the year. The basis for the 5-pound requirement was the fact that the wheelchair athletes can use other devices that require at least that amount of force, though the force gauge we used to test at the time maxed out at 5 pounds. For the actual ability to use the device, two different wheelchair athletes were able to activate the device on their own, showing that our initial 5-pound requirement was far too low. Despite failing this test, the device is still usable.

The weight of each separate subsystem of the device must not weigh more than 30 pounds, so that it is easier for one person to set it up alone. The two subsystems measured were the frame, 27.2 pounds, and the tabletop, 15.6 pounds, which passed.

Time trials were performed with each of the team members to measure the set up time and reset time of our device. This does not include the setup of the UPF. The reset time was measured as time in between the user having any activity, so from the previous launch to being ready to crank back.

The shooting range of our launcher was measured from where the ball hit the ground, which came out to an average of 20 feet. This does not pass our requirements however, because the ball must be at least 10 feet high in order to make a basket, so the real range of the shot was somewhere around 15 feet. Note that this is from what the team considered a “reasonable”

amount of winding of the rope to launch it. Much more than the distance that it was pulled, and the higher likelihood of failure of parts, since it is not designed to go past the distance we pulled it. The launcher has been capable of shooting three-pointers (20 feet), but due to failure of the rope stopper on a test launch, the safe distance to shoot it from has been scaled back to 15 feet.

The angle of the frame was measured using a level app on an iPhone, which when at full tilt was shown to be exactly 60 degrees. The carriage travels smoothly over the guide rails.

Throughout testing, there was no deflection observed in the winch shaft, no fraying of the rope, and no slipping of elastic once the U-bolts were tightened. It was observed that some minor cracking was occurring on one piece of the elastic due to the tightness of the U-bolts, which was minimized by re-clamping the U-bolts ensuring pinch points on the elastic are avoided.

After conducting our official testing our device was tested with the Friday Club members, and then with members of the general public at the Senior Project Expo. Overall, the device received positive feedback and at Expo about ten successful baskets were made from the free-throw line over a three hour period.

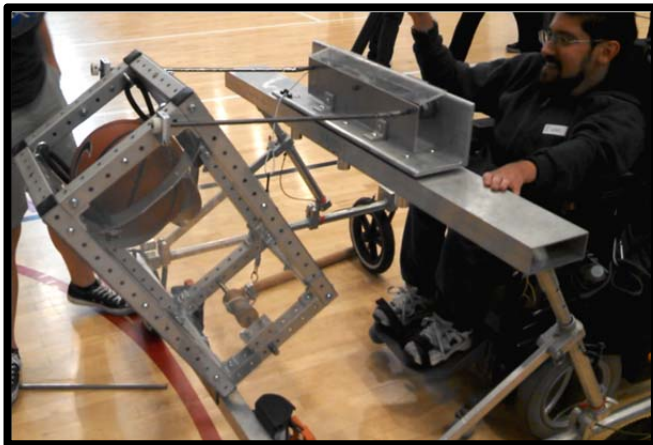

Figure 46. Testing at the Friday Club



Figure 47. The Engineering Team at the Senior Project Expo

Recommendations and Conclusions

While our device meets most of the customer's requirements, its largest fault is that it cannot shoot from the three-point line. The final prototype can shoot a basket safely from a distance of 15 feet, which is the distance of a free throw. To expand the range of our device, the height of the frame could be increased, allowing for more room to pull back the elastic.

Looking back on the design of the project, there were some parts that could be improved. Particularly, the design of the carriage could be upgraded. First, the original design was for the carriage was to bend the 6061 aluminum into shape and then bolt them together. Unbeknownst to the team, 6061 cannot bend 90 degrees without breaking. Also, the shape of the carriage causes the ball to sit to one side, causing misfires when the UPF is not on level ground. The carriage also has been deforming due to the impact force, so a thicker top plate of aluminum than 1/8" or possibly stronger metal such as steel may better be able to handle the force of impact. Another possibility to reduce this impact deformation is to include two more rubber stoppers on the other sides of the frame, distributing the load.

Another recommendation would to choose a different way to make the tabletop rather than a huge angle stock piece. This is a little bit cumbersome and wasteful. The lead screws also take a long time to get the frame into the proper position, so a different pulley ratio could help with the speed. Also, the frame of our device can currently move back and forth along the lower front bar of the UPF. In the future, it would be useful to alter the u-channel attachment points so that they clamp onto the UPF. During testing, we noticed that the ratchet arm would sometimes run into the adjacent lead screw hinge, scoring the wooden lever. This could be fixed in a few different ways: the hex bolt could be lengthened, the lead screw hinge could be made thinner, or some material could be placed on the hinge to guard the lever from damage. Drilling holes in the polycarbonate safety casing sheets was time consuming, so a quicker method of attachment, like high-strength Velcro, may be an easier way to attach the safety casing to the frame. One other thing we noticed was that the sharp edges on the ferrules holding the rope on the winch shaft could damage the rope. A way to avoid this would be to use strong knots instead of ferrules to secure the rope.

In all, the task of developing an adaptive basketball launcher with force, size, and attachment constraints has been a challenging problem. However, with extensive research of pre-existing designs and customer requirements, we believe we have made a basketball launcher that is safe, fun, and meets most customer requirements. The two Friday Club participants we tested with both found the device to require an appropriate level of physical activity and had fun using the device. In all, Friday Club participants will use and enjoy our device for years to come.

References

"Basketball Shooter for R&C Expo." YouTube. Ohio University, 11 May 2010. Web. 23 Oct. 2013. <<http://www.youtube.com/watch?v=xFfmGFWOMvo>>.

"Captains Chaise Lounge Chair." *Plastic Lumber Yard*. N.p., n.d. Web. 1 Nov. 2013. <<http://www.plasticlumberyard.com/FURNITURE/captainchaiseloungeCH7826.htm>>.

"Compressive Stiffness of Neoprene Rubber." *Eng-Tips Forums*. 6 Aug. 2003. Web. 4 Feb. 2014. <<http://www.eng-tips.com/viewthread.cfm?qid=66682>>.

"FRC 2012 Ball Launcher by IR3 Creative." YouTube. IR3 Creative, 09 Jan. 2012. Web. 23 Oct. 2013. <<http://www.youtube.com/watch?v=DO0XzkthMUs>>.

Gode, Yash. "Basketball Court Diagram with Labels." *Buzzle*. N.p., 30 Mar. 2010. Web. 03 Oct. 2013. <<http://www.buzzle.com/articles/basketball-court-diagram.html>>

Hansen, Christopher L. "Sports Ball Launcher." Google Patents. N.p., 14 Oct. 2004. Web. 23 Oct. 2013. <http://www.google.es/patents/about/7028682_Sports_ball_launcher.html?id=yhh3AAAAEBAJ>.

"Jaw Coupling." *ABSSAC Power Transmission*. N.p., n.d. Web. 12 Nov. 2013. <http://www.abssac.co.uk/s/Jaw_coupling/3/39/>.

Locatelli, Roberto. "Pivot Points and Angle of Rotation." *Cornucopia3D*. N.p., 3 Jan. 2006. Web. 07 Jan. 2014. <<http://www.cornucopia3d.com/forum/viewtopic.php?t=12037&highlight=>>.

Normal for Us: The Miller Twins. PBS. Southberlington, Vermont, 2002. Television.

"Rugged Ridge - ATV/UTV HD Winch." *CARID.com*. N.p., n.d. Web. 1 Nov. 2013. <<http://www.carid.com/universal-winch/rugged-ridge-winch-4430897.html>>.

"Shoot-A-Way." Original Shoot-A-Way. N.p., n.d. Web. 23 Oct. 2013. <<http://www.shootaway.com/equipment/original-shoot-a-way>>.

Stumpf Balloons. "'Three Ring Circus' Quick Release." *Nebraska Balloon Club*. N.p., n.d. Web. 3 Nov. 2013. <http://www.nebraskaballoonclub.org/photoview.html?image=glossary/images/3ringcircus_lg.jpg?caption=%22Three%20Ring%20Circus%22%20Quick%20Release%20-%20photo%20courtesy%20Stumpf%20Balloons>

Sprave, Joerg. "How to Make + Use a Mechanical Slingshot Release." *YouTube*. N.p., 15 Aug. 2010. Web. 21 Oct. 2013. <<http://www.youtube.com/watch?v=ics5W9K0YNM>>.

Appendix A – QFD and Pugh Matrices

QFD (House of Quality)

Quality Function Deployment (QFD) is a tool that helps demonstrate graphically the relationships between the requirements desired by the sponsor and engineering specifications. The requirements desired by the sponsor are shown on the left-most column, and the engineering specifications are the vertical columns at the top. Weighting was determined by comparing all requirements against each other and ranking their importance. Higher point value correlates to more importance. Each sponsor requirement was compared against each engineering specification to determine how much of a correlation there is between the two. Levels of correlation are shown with different symbols. A key is found below the QFD. Strong correlation between the customer and engineering requirements shows that meeting the engineering requirement will ensure that the customer requirement is met.

On the right-hand side, the benchmark columns are displayed. These benchmarks are pre-existing products that perform similar tasks to the problem at hand. The numbering within the columns describes how well those products meet the sponsor requirements. This allows us to see the benefits and pitfalls of the existing products.

The bottom section quantifies our engineering requirements. It gives specific goals that will ensure the customer requirements are met. Below these target values are the existing solutions, with their estimated specifications. Again, this allows our team to easily compare our target specifications to the pre-existing products to quantitatively determine their benefits and pitfalls.

The QFD is attached on the following page.

Quality Function Deployment - UPF Ballers

Customer Requirements (Whats)		Engineering Requirements (HOWS)											Benchmarks		
		Weighting (Total 100)	Weight	Set-up time	Dimensions	Max Launch Distance	Reset Time	Hand Motion Sphere	Operating Force	Time Before Maintenance	Cost	Compartments	Max Height	Ohio U: Basketball Slingshot	4 Flywheel Mech.
Customer Requirements	Quick & Easy Setup	1.1	●	●								○	Δ	4	3
	Attach to UPF	7.7	○	○				Δ				●	Δ	1	1
	Fit in Storage Area	3.3	Δ	Δ	●							Δ	○	3	5
	Play Game of "Horse"	10.4	Δ	Δ		●	●	Δ	○				Δ	5	5
	Use in Joystick chair	12.1						○	●					2	1
	left- or right-handed	2.2										Δ		1	5
	Adjustable (size)	4.4		Δ				●	○			Δ		1	1
	Physical Activity	6.6						○	●					5	2
	Least Restr. Envr.	8.8		Δ		●	○	●	●			Δ	○	5	2
	Safe	14.3	○			Δ	Δ		○	○			Δ	4	2
	Fun	10.4		○		●	○	Δ	○	Δ				5	5
	Durable	13.2				●			Δ	●				5	3
	Cost-Effective	0.0									●			4	5
	Retain line-of-sight	5.5			Δ	Δ						○	●	5	5
Units			pounds	minutes	ft x ft x ft	feet	seconds	inches	pounds	years	dollars	number	feet		
Target			30	5	2 x 3 x 3	20	30	6	5	2	1500	2	2		
Ohio U: Bball Slingshot			-	1	1 x 3 x 3	25	30	18	-	-	-	1	3		
4 Flywheel Mech.			-	0.5	1 x 1 x 0.75	24	0	3	1.4	-	-	1	2		





- = 9 Strong Correlation
- = 3 Medium Correlation
- Δ = 1 Small Correlation
- Blank No Correlation

- Benchmark Ratings**
- 1 Doesn't meet requirement
 - 3 Moderately meets requirement
 - 5 Meets requirement extremely well

Pugh Matrices

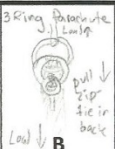
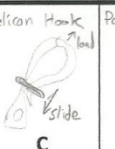
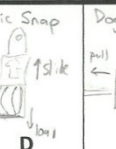
A Pugh Matrix is decision-making tool which lays out many different concepts for a given idea and compares them to a standard which is called a “datum”, rating them as either better (+), the same (S) or worse (-). This method is not a definitive way of determining which solution is most appropriate. Rather, it helps our team to see the benefits and deficits of each individual concept. Pugh Matrices for two main functions (aiming/mounting and release) can be found in the following pages.

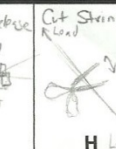
Pugh Matrix – Release Mechanisms for Basketball Shooter

	 Pull-Pin A	 3 Ring Paracord Loop B	 Pelican Hook C	 Panic Snap D	 Dog Clutch E	 Tugboat Release F	 Slingshot Release G	 Cut String H
1	D	+	+	+	+	+	S	+
2	D	-	S	S	+	S	+	-
3	D	-	S	S	+	S	S	S
4	D	-	-	-	-	-	-	+
5	D	-	-	S	+	S	S	S
6	D	S	S	S	S	S	S	S
7	D	S	+	+	S	S	+	-
8	D	-	-	-	-	-	-	+
9	D	+	+	+	+	S	+	-
$\Sigma +$	0	2	3	3	5	1	3	3
$\Sigma -$	0	5	3	2	2	2	2	3
ΣS	0	2	3	4	2	6	4	3

Criteria

1. Low force to actuate
2. Easy to reset
3. Must integrate smoothly with pull-back mechanism
4. Less Expensive
5. Reliable
6. Must allow for ball to release
7. Must allow for release by pulling motion
8. Simplistic
9. Safe

From this matrix, the frontrunner is Concept E, the dog clutch system. Compared to our datum, a pull pin, it either excels or compares in all criteria except for two. These criteria are cost and simplicity. However, in my mind these are two of the least-important criteria. While a dog clutch is more expensive than a pull pin, it still costs a reasonable amount (around \$30). And while it would be more complicated to manufacture ourselves, if it can be bought, it is effectively as simple as a pull-pin.

Before completing this study, my group was under the impression that a spring-loaded slingshot release (Concept G), would be the best concept to go with. However, with the help of this matrix, it became clear that this concept has many moving parts, meaning it will likely be more expensive, less reliable, and less easy to reset than we had hoped.

UPF BALLERS
AIMING & MOUNTING PUGH MATRIX
BRETT NAYUDU
ME428-01

	Setup 1	Setup 2	Setup 3	Setup 4	Setup 5	Ohio Device
Easily Attaches to UPF	+	+	+	+	+	D
Easily Removed from UPF	+	+	+	+	+	D
Can Be Set Up By One Person	S	+	S	+	+	D
Can Change Angle in Vertical and Horizontal Direction	+	+	S	+	+	D
Stable	S	-	S	S	S	D
Physical Activity	-	S	-	-	-	D
Usable with Limited Range of Motion	+	-	+	S	+	D
Requires Little Force to Move/Activate	+	S	+	S	S	D
$\Sigma+$	5	4	4	4	5	0
$\Sigma-$	1	2	1	1	1	0
ΣS	2	2	3	3	2	0

* See "setups" on attached sheets *

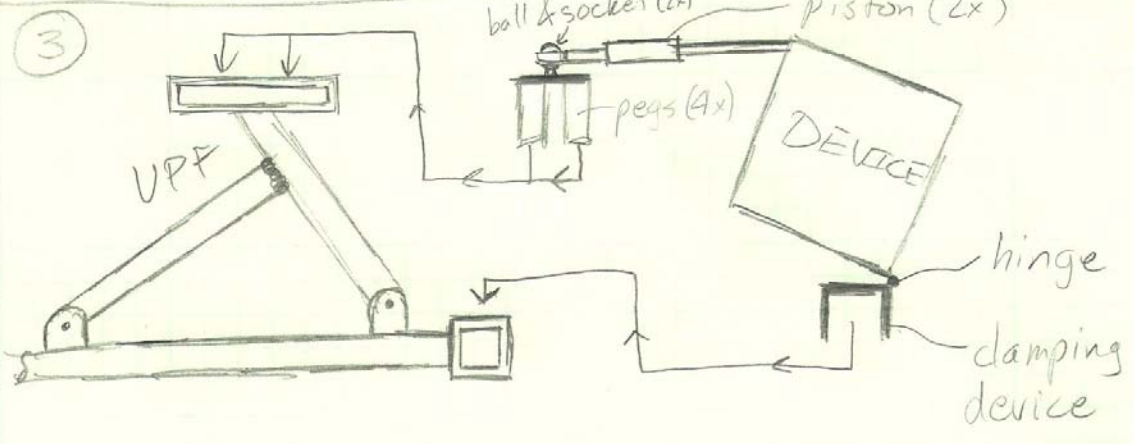
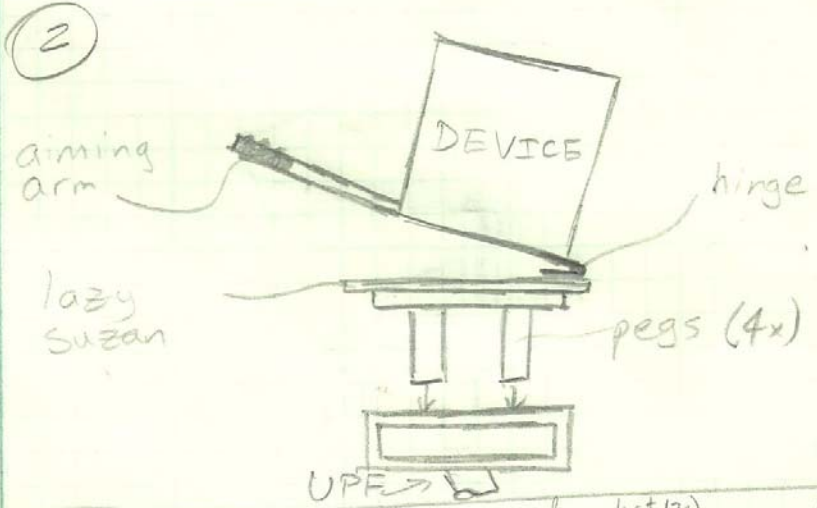
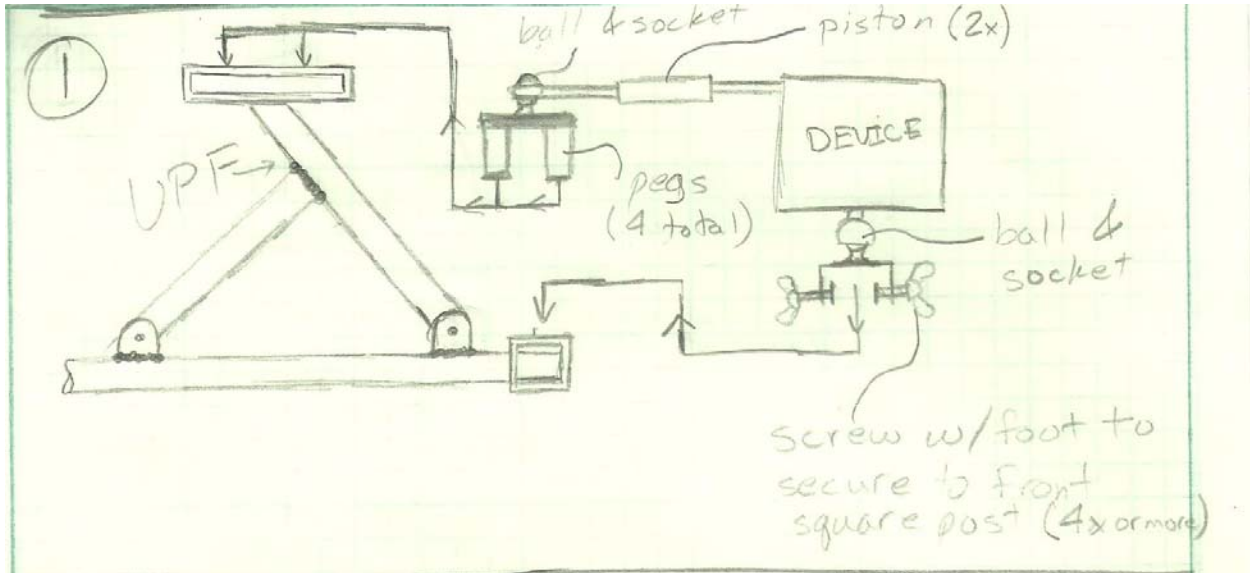

4

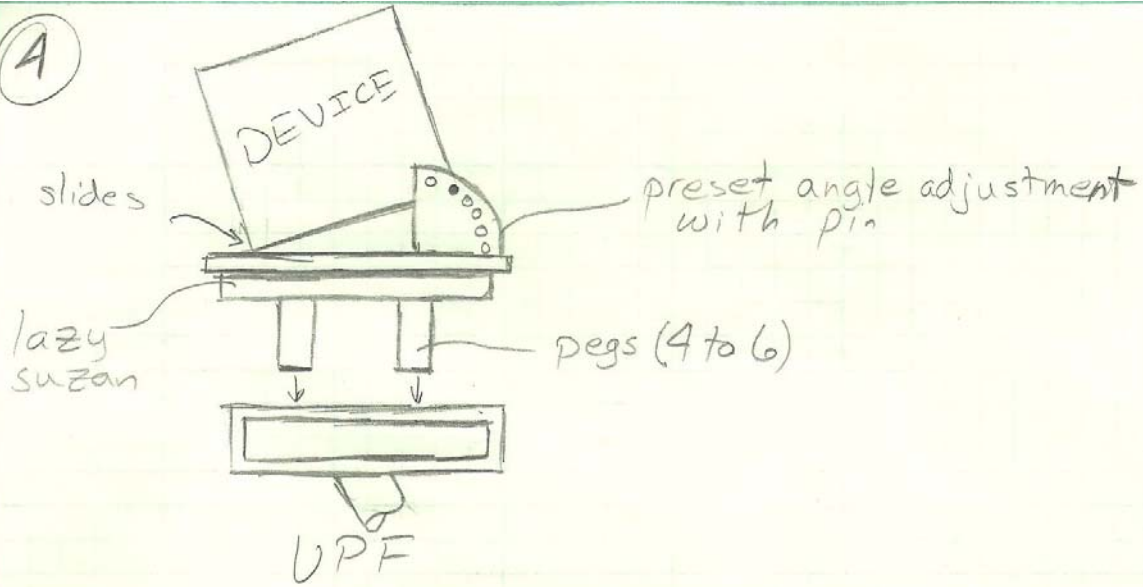

5

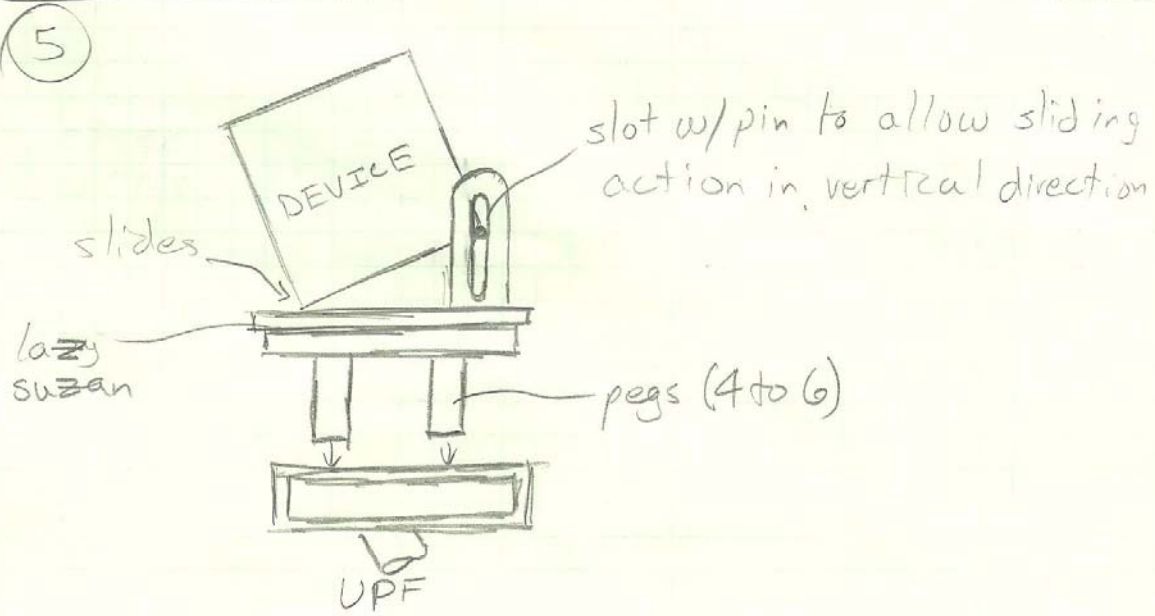

Appendix B – Bill of Materials

Table 4. Full Bill of Materials

	Part	Stock Title	Vendor	Part#	Unit Cost	Qty Reqd	Total Cost
Frame	Long Frame Tube	Aluminum Bolt-Together Framing	McMaster	8809T11	\$ 24.44	5	\$ 122.20
	Top Frame Tube						
	Top Frame Tube 2						
	Bottom Tube 1						
	Bottom Tube 2						
	Pawl Block						
	L-Bracket	90 deg. Corner Connecting Bracket	McMaster	8809T62	\$ 5.19	16	\$ 83.04
	End Cap for Long Frame Tube	End Cap for Aluminum Bolt-Together Framing	McMaster	8809T41	\$ 1.16	4	\$ 4.64
	Bolts for Frame	Black-Oxide Alloy Steel Socket Head Cap Screw, 5/16"-24 Thread, 7/8" Length	McMaster	91251A382	\$ 5.61	2	\$ 11.22
	Nuts for Frame	Plain Grade 8 Steel Hex Nut, 5/16"-24 Thread Size, 1/2" Width, 17/64" Height	McMaster	90499A810	\$ 4.93	1	\$ 4.93
	Main Hinge	Steel Mortise-Mount Hinge w/ Bearings, Removable Pin, Dull Bronze, 3-1/2" High, 3-1/2" Wide	McMaster	1502A21	\$ 15.83	2	\$ 31.66
	Intermediate Hinge Steel	Low-Carbon Steel Rectangular Bar, 1/4" Thick, 1-1/2" Width	McMaster	8910K553	\$ 4.07	1	\$ 4.07
	Hinge-UPF U-Channel	2 X 2 X 11 GA (.120 wall) A500 Steel Structural Square Tube	Metals Depot	T12211	\$ 10.12	1	\$ 10.12
	Hinge to Intermediate Bolts	18-8 Stainless Steel Flat Head Phillips Machine Screw, 8-32 Thread, 5/16" Length	McMaster	91771A191	\$ 5.80	1	\$ 5.80
	Hinge to Frame Bolts	18-8 Stainless Steel Flat Head Phillips Machine Screw, 8-32 Thread, 2" Length	McMaster	91771A205	\$ 10.02	1	\$ 10.02
	Hinge to Frame Nuts	Zinc-Plated Grade 2 Steel Nylon-Insert Hex Locknut, 8-32 Thread Size, 11/32" Width, 15/64" Height	McMaster	90631A009	\$ 2.35	1	\$ 2.35
	5/16 24 Elastic Eye Bolt	Steel Eyebolt with Shoulder for Lifting, 5/16"-24 Thread Size	McMaster	3014T257	\$ 5.11	4	\$ 20.44
	Nuts for Eye Bolt	Grade 8 Steel Nylon-Insert Hex Locknut, Zinc-Yellow Plated, 5/16"-24 Thread Size, 1/2" Wide, 11/32" High	McMaster	97135A225	\$ 3.88	1	\$ 3.88
	Polycarbonate Casing Front	Impact-Resistant Polycarbonate Sheet, 1/16" Thick, 24" x 36", Clear	McMaster	8574K245	\$ 21.98	2	\$ 43.96
	Polycarbonate Casing Back						
	Polycarbonate Casing Right						
	Polycarbonate Casing Left Upper						
	Polycarbonate Casing Left Lower						
	Hinge for Polycarb Door	Mortise Nontemplate Hinge with Nonremovable Pin, Square Corners, Plain Steel, 1" Height, 1" Width	McMaster	1598A12	\$ 0.77	2	\$ 1.54
	Screws for Hinge	Alloy Steel Flat-Head Socket Cap Screw, 4-40 Thread, 5/32" Long, Black Oxide	McMaster	91253A111	\$ 9.20	1	\$ 9.20
	Nuts for Hinge	Zinc-Plated Steel Machine Screw Hex Nut, 4-40 Thread Size, 1/4" Width, 3/32" Height	McMaster	90480A005	\$ 0.81	1	\$ 0.81
	Bolts for Polycarb	Alloy Steel Button-Head Socket Cap Screw, Black-Oxide, 5/16"-24 Thread, 2" Long	McMaster	91255A042	\$ 8.29	4	\$ 33.16
	Nuts for Polycarb	Plain Grade 8 Steel Hex Nut, 5/16"-24 Thread Size, 1/2" Width, 17/64" Height	-	-		Listed Above	\$ -
Latch for Polycarb Door	Steel Barrel Slide Bolt, Black Finish, 1-3/4" x 1-1/2" Plate	McMaster	1441A12	\$ 2.66	1	\$ 2.66	
Bolts for Latch	Type 316 Stainless Steel Pan Head Phillips Machine Screw, 6-32 Thread, 1/4" Length	McMaster	91735A144	\$ 4.16	1	\$ 4.16	
Nuts for Latch	Zinc-Plated Grade 2 Steel Nylon-Insert Hex Locknut, 6-32 Thread Size, 5/16" Width, 11/64" Height	McMaster	90631A007	\$ 2.67	1	\$ 2.67	
Carriage	Guide Rod	1/2" dia. 303 Stainless Steel TGP Precision Shafting	Metals Depot	R412-303TP	\$ 14.00	2	\$ 28.00
	Bolts to Hold Guide Rod to Frame	Alloy Steel Button-Head Socket Cap Screw, Black-Oxide, 5/16"-24 Thread, 2" Long	McMaster	91255A042	\$ 8.29	1	\$ 8.29
	Nuts for Guide Rod	Grade 8 Steel Nylon-Insert Hex Locknut, Zinc-Yellow Plated, 5/16"-24 Thread Size, 1/2" Wide, 11/32" High	-	-		Listed Above	\$ -
	Rubber Stopper	Black Polyurethane Tubing, 1-1/4" OD, 1/2" ID, 6" Long	McMaster	87235K12	\$ 16.02	1	\$ 16.02
	Bearing for Primary Support	Graphite SAE 841 Bronze Sleeve Bearing for 1/4" Shaft Diameter, 5/16" OD, 3/4" Length	McMaster	9368T105	\$ 0.86	1	\$ 0.86
	Carriage Primary Support	.125 (1/8) thick 6061 Aluminum Sheet	Metals Depot	53186	\$ 52.92	1	\$ 52.92
	Carriage Secondary Support						
	Carriage Top						
	Carriage Bolts	Type 316 Stainless Steel Pan Head Phillips Machine Screw, 10-32 Thread, 1/2" Length	McMaster	91735A829	\$ 4.98	1	\$ 4.98
	Carriage Nuts	Zinc-Plated Grade 2 Steel Nylon-Insert Hex Locknut, 10-32 Thread Size, 3/8" Width, 15/64" Height	McMaster	90631A411	\$ 2.81	1	\$ 2.81
	Linear Sleeve Bearing	Steel Flange-Mount Linear Ball Bearing, Square Flange, 1/2" Shaft Diameter, 1-1/4" Overall Length	McMaster	6483K63	\$ 32.67	2	\$ 65.34
	Bolts for Linear Sleeve Bearing	Type 316 Stainless Steel Pan Head Phillips Machine Screw, 8-32 Thread, 5/8" Length	McMaster	91735A196	\$ 8.11	1	\$ 8.11
	Nuts for Linear Sleeve Bearing	Zinc-Plated Grade 2 Steel Nylon-Insert Hex Locknut, 8-32 Thread Size, 11/32" Width, 15/64" Height	-	-		Listed Above	\$ -
	Latex Tubing	Super Soft Latex Rubber Tubing, 1/8" ID, 1/2" OD, 3/16" Wall Thickness	McMaster	5234K65	\$ 2.45	5	\$ 12.25
Ratchet Handle	Hex to Ratchet Attachment	1/2" Square Drive Socket, 6-Point Standard, 9/16" Size, 1-1/2" Overall Length, Chrome Finish	McMaster	5545A14	\$ 6.24	1	\$ 6.24
	Ratchet Wrench	Stanley 91-930 1/2-Inch Drive Pear Head Quick Release Ratchet	Amazon	-	\$ 13.99	1	\$ 13.99
	Ratchet Lever	Wood, Oak Dowel Rod, 1-1/2" Diameter, 36" Length	McMaster	96825K85	\$ 26.44	1	\$ 26.44
	Removable Crank Pin	316 Stainless Steel Clevis Pin with Cotter Pin, 5/16" Diameter, 1-3/4" Long, 1-1/2" Usable Length	McMaster	92401A662	\$ 6.05	1	\$ 6.05
	Collar - Wood to Wrench Handle	Worm-Drive Hose Clamp with Zinc Plated Steel Screw, 1-3/16" to 1 3/4" Clamp Diameter Range, 5/16" Band Width	McMaster	5388K26	\$ 8.30	1	\$ 8.30

	Part	Stock Title	Vendor	Part#	Unit Cost	Qty Reqd	Total Cost
Winch Shaft	Winch Shaft	1/2" dia. 303 Stainless Steel TGP Precision Shafting	Metals Depot	R412-303TP	\$ 14.00	1	\$ 14.00
	Winch Bearing	Graphite SAE 841 Bronze Sleeve Bearing for 1/2" Shaft Diameter, 5/8" OD, 1.5" Length	McMaster	9368T157	\$ 2.44	2	\$ 4.88
	Wooden Spool	2" Red Oak Dowel Rod	Baird Brothers	DR2-OAK	\$ 6.84	1	\$ 6.84
	Spool Set Screw	Type 316 Stainless Steel Cup Point Set Screw, 1/4"-20 Thread, 1-1/2" Long	McMaster	92313A549	\$ 6.43	1	\$ 6.43
	Ratchet	303 Stainless Steel Ratchet, 16 Pitch, 1-1/2" OD	McMaster	6283K24	\$ 37.11	1	\$ 37.11
	Ratchet Flange	High Strength 1144 Medium Carbon Steel Rod, 1-1/4" Diameter	McMaster	6628K54	\$ 15.26	1	\$ 15.26
	Ratchet Flange Set Screw	Type 316 Stainless Steel Cup Point Set Screw, 4-40 Thread, 1/4" Long	McMaster	92313A106	\$ 3.45	1	\$ 3.45
	Bolts for Ratchet Flange	Low-Profile Button Head Torx Machine Screw, 18-8 Stainless Steel, 6-32 Thread, 3/4" Length	McMaster	90910A741	\$ 9.12	1	\$ 9.12
	Nuts for Ratchet Flange	Zinc-Plated Grade 2 Steel Nylon-Insert Hex Locknut, 6-32 Thread Size, 5/16" Width, 11/64" Height	McMaster	90631A007	\$ 2.67	1	\$ 2.67
	Spacer between Ratchet and Frame	Black Delrin * Acetal Resin Rod, 5/8" Diameter	McMaster	8576K17	\$ 11.55	1	\$ 11.55
	Pawl	3/8" Thick Stainless Steel Pawl	McMaster	6283K32	\$ 45.22	1	\$ 45.22
	Pawl Spacer	Black Delrin * Acetal Resin Rod, 5/8" Diameter	-	-	Listed Above	\$ -	
	Pawl Shoulder Screw	Type 316 Stainless Steel Shoulder Screw, 1/2" Diameter x 3/4" Long Shoulder, 3/8"-16 Thread	McMaster	97345A707	\$ 7.16	1	\$ 7.16
	Bolts for Pawl Block	Alloy Steel Button-Head Socket Cap Screw, Black-Oxide, 5/16"-24 Thread, 2" Long	McMaster	91255A042	\$ 8.29	4	\$ 33.16
	Nuts for Pawl Block	Plain Grade 8 Steel Hex Nut, 5/16"-24 Thread Size, 1/2" Width, 17/64" Height	-	-	Listed Above	\$ -	
	Aiming/Table Top	Hex Bolt for Shaft	Low-Carbon Steel Hex Bar, 1/2" Hex Size	McMaster	6512K181	\$ 13.57	1
Lead Screw Hinge		Multipurpose 6061 Aluminum, 1/2" Thick, 2" Width, 1" Length	McMaster	8975K741	\$ 4.01	1	\$ 4.01
Pin for Lead Screw Hinge		18-8 Stainless Steel Clevis Pin, 5/16" Diameter, 3-1/2" Length, 3-1/4" Usable Length	McMaster	92390A234	\$ 12.42	1	\$ 12.42
Lead Screw Hinge Spacer		Black Delrin * Acetal Resin Rod, 5/8" Diameter	-	-	Listed Above	\$ -	
Lead Screw Cylinder Nut		Brass General Purpose ACME Cylinder Nut, Right-Hand, 3/8"-12 ACME Size	McMaster	95100A101	\$ 4.99	2	\$ 9.98
Lead Screw		ASTM A193 Grade B7 ACME Threaded Rod, Alloy Steel, Right Hand, 3/8"-12 ACME Size, 3' L	McMaster	93410A609	\$ 18.97	1	\$ 18.97
Shaft Collars as Lead Screw Stops		One-Piece Clamp-on Shaft Collar for 3/8" Diameter, Nylon	McMaster	9410T3	\$ 8.53	2	\$ 17.06
Universal Joint		Pin-and-Block U-Joint, Unbored Ends, Steel, Single Joint, 3/8" Shaft Diameter	McMaster	6443K12	\$ 43.27	2	\$ 86.54
Springy Pin for U-Joint		18-8 Stainless Steel Slotted Spring Pin, 1/16" Diameter, 1/2" Length	McMaster	92373A109	\$ 6.78	1	\$ 6.78
Pulley Shaft		High Strength 1144 Medium Carbon Steel Rod, 3/8" Diameter	McMaster	6628K264	\$ 10.85	2	\$ 21.70
Crank Shaft			McMaster				
Crank Handle			Aluminum Crank Handle, 3/8" Unthreaded Through Hole, Revolving, 3.49" Handle	McMaster	6473K76	\$ 19.38	1
Pulley Spacer Left Short		Black Delrin * Acetal Resin Rod, 5/8" Diameter	-	-	Listed Above	\$ -	
Pulley Spacer Left Long			-	-	Listed Above	\$ -	
Pulley Spacer Right Long			-	-	Listed Above	\$ -	
Large Pulley and Set Screw		L and H Series Timing Belt Pulley, L-Series, Fit 1/2" Belt Width, 1.672" OD, 12 Teeth	McMaster	6495K24	\$ 22.85	2	\$ 45.70
Small Pulley and Set Screw		L and H Series Timing Belt Pulley, L-Series, Fit 1/2" Belt Width, 1.438" OD, 10 Teeth	McMaster	6495K23	\$ 17.99	2	\$ 35.98
Belt		Trapezoidal Tooth Neoprene Timing Belt, 3/8" Pitch, Trade Size 195L, 19.5" Outer Circle, 1/2" Wide	McMaster	6484K113	\$ 10.11	2	\$ 20.22
Support Plate		.125 (1/8) thick 6061 Aluminum Sheet	McMaster	-	\$ -	1	\$ -
L-Bracket		90 deg. Corner Connecting Bracket	McMaster	8809T62	\$ 5.19	4	\$ 20.76
L-Bracket Bolts Long		18-8 Stainless Steel Button-Head Socket Cap Screw, 5/16"-24 Thread, 7/8" Long	McMaster	92949A859	\$ 7.14	1	\$ 7.14
L-Bracket Bolts Short		18-8 Stainless Steel Button-Head Socket Cap Screw, 5/16"-24 Thread, 3/8" Length	McMaster	92949A595	\$ 5.92	1	\$ 5.92
L-Bracket Nuts		Plain Grade 8 Steel Hex Nut, 5/16"-24 Thread Size, 1/2" Width, 17/64" Height	-	-	Listed Above	\$ -	
Table Top		5 x 5 x 3/8 Al Angle 6061	Metals Depot	A35538	\$ 57.18	1	\$ 57.18
Table Top Pegs		Multipurpose 6061 Aluminum Rod, 1-1/4" Diameter	McMaster	8974K16	\$ 20.89	1	\$ 20.89
Aiming Support Bearings		Graphite SAE 841 Bronze Sleeve Bearing for 1/4" Shaft Diameter, 5/16" OD, 3/4" Length	McMaster	9368T105	\$ 0.86	1	\$ 0.86
Aiming Table Top Bearings		SAE 841 Bronze Sleeve Bearing for 3/8" Shaft Diameter, 1/2" OD, 3/8" Length	McMaster	6391K172	\$ 0.83	3	\$ 2.49
Release	Lever Bracket	Panel Hanging Bracket, Chrome-Plated Zinc, 1" Maximum Thickness, 2-1/2" Deep (comes with screws)	McMaster	1755A32	\$ 8.77	1	\$ 8.77
	Lever Arm	Black Delrin * Acetal Resin Rod, 1-1/4" Diameter	McMaster	8576K23	\$ 7.37	1	\$ 7.37
	Bolt for Lever	Black-Oxide Alloy Steel Socket Head Cap Screw, 1/2"-20 Thread, 1-3/4" Length	McMaster	91251A018	\$ 5.70	1	\$ 5.70
	Nut for Lever	Plain Grade 8 Steel Nylon-Insert Hex Locknut, 1/4"-20 Thread Size, 7/16" Width, 5/16" Height	McMaster	90630A110	\$ 3.18	1	\$ 3.18
	Pull Cable and Sleeve	Shimano Brake Cable and Housing Set (Universal)	Amazon	-	\$ 12.97	1	\$ 12.97
	Carabiner	Black Powder-Coated Steel Carabiner Connector, 1/4" Snap Opening, 1/4" Eye Diameter, 175 lb Work Load Limit	McMaster	3079T41	\$ 1.35	1	\$ 1.35
	Winch Nylon Rope	Twisted Shock-Absorbing Nylon Rope, 3/16" Diameter, 75 lb Work Load Limit	McMaster	3827T31	\$ 9.15	1	\$ 9.15
	Pull Pin	3/8 inch Hand-Retractable Spring Plunger	Fastening Solutions	RET-375	\$ 7.55	1	\$ 7.55
	Release Bracket	Multipurpose 6061 Aluminum, 1/2" Thick, 2" Width, 1" Length	McMaster	-	Listed Above	\$ -	
	Bearing for Release Bracket	Graphite SAE 841 Bronze Sleeve Bearing for 1/4" Shaft Diameter, 5/16" OD, 3/4" Length	-	-	Listed Above	\$ -	
Total:							\$ 1,347.87

Appendix C – Supporting Analysis

Energy Required to Shoot 3-Pointer

Given: From experimentation, we know the time to get to the basket is approximately 1.5 seconds. The height of the launcher will be 4 feet, and the basket height is 10 feet, and the distance to the basket is 20 feet. The ball weighs 22 oz.

Find: Initial speed of ball, energy required

Analysis:

Kinematics

$$t = 1.5s$$

$$x = 20 \text{ ft}$$

$$g = -32.2 \text{ ft/s}^2$$

$$W = 22 \text{ oz} / (16 \text{ oz/lbf})$$

$$W = 1.375 \text{ lbf}$$

$$W = m * g$$

$$m = W / g$$

$$m = 1.375 \text{ lbf} / (32.2 \text{ ft/s}^2)$$

$$m = 0.0427 \text{ slugs}$$

$$i: x = v_{ox} * t$$

$$v_{ox} = x/t$$

$$v_{ox} = 20\text{ft}/1.5 \text{ s}$$

$$v_{ox} = 13.3 \text{ ft/s}$$

$$j: \Delta y = (10 - 4) \text{ feet}$$

$$\Delta y = 6 \text{ feet}$$

$$\Delta y = 1/2 * g * t^2 + v_{oy} * t$$

$$6 \text{ ft} = -16 \text{ ft/s}^2 * (1.5\text{s})^2 + 1.5 \text{ s} * v_{oy}$$

$$v_{oy} = 28 \text{ ft/s}$$

Magnitude:

$$V = (v_{ox}^2 + v_{oy}^2)^{1/2}$$

$$V = ((13.3 \text{ ft/s})^2 + (28 \text{ ft/s})^2)^{1/2}$$

$$V = 31.0 \text{ ft/s}$$

Energy:

$$W = m * g$$

$$m = W / g$$

$$m = 1.375 \text{ lbf} / (32.2 \text{ ft/s}^2)$$

$$m = 0.0427 \text{ slugs}$$

$$K = 1/2 * m * V^2$$

$$K = 1/2 * 0.0427 \text{ slugs} * (31.0 \text{ ft/s})^2$$

$$K = 20.5 \text{ ft} - \text{lb}$$

Total Potential Energy Required (+ Carriage)

In order to get our ball up to speed we will need to put energy into not only the ball, but the carriage as well.

Find: Energy needed to get ball and carriage up to speed

Analysis:

Energy:

$$m_{ball} = 1.375/32.2 \text{ slug}$$

$$m_{carriage} = \frac{1}{32.2} \text{ slug}$$

$$V_o = 31 \frac{ft}{s}$$

$$h = \left(\frac{14}{12}\right) * \sin(60^\circ)$$

$$g = -32.2 \frac{ft}{s^2}$$

$$E = \frac{1}{2} m_{carriage} V_o^2 + \frac{1}{2} m_{ball} V_o^2 + (m_{ball} + m_{carriage})gh$$

$$E = \frac{1}{2} * \left(\frac{1}{32.2} \text{ slug}\right) * (31^2 \text{ ft}^2/\text{s}^2) + \frac{1}{2} * \left(\frac{1.375}{32.2} \text{ slug}\right) * (31^2 \text{ ft}^2/\text{s}^2) + \left(\frac{1 + 1.375}{32.2} \text{ slug}\right) * (32.2 \text{ ft}/\text{s}^2) * \left(\frac{14}{12} \text{ ft}\right) * \sin(60^\circ)$$

$$E = 36.3 \text{ ft} \cdot \text{lb} \text{ (OR } 435.6 \text{ in} \cdot \text{lb)}$$

Residual Energy in Carriage:

At the very first moment of impact the ball will no longer be part of the system, but the carriage will still have residual energy that will be dispersed through our rubber stoppers.

$$\text{Residual Energy} = \frac{1}{2} * m_{carriage} * V_o^2$$

$$\text{Residual Energy} = \frac{1}{2} * \left(\frac{1}{32.2} \text{ slug}\right) * \left(31 \frac{ft}{s}\right)^2$$

$$\text{Residual Energy} = 14.25 \text{ ft} \cdot \text{lb}$$

Impact Loading of Frame, Lead Screws, and Base Hinge

Given: Rubber is Polyurethane, 40 A

Young's Modulus= $E=1.5$ MPa, or $E= 217.6$ psi

Using this to obtain an estimate for the stiffness, k:

$$\delta = PL/EA$$

$$k = F / \delta = EA/L$$

Dimensions of Rubber Stopper:

$$ID = 0.5 \text{ in}, OD = 1.25 \text{ in}, L = 3 \text{ in}$$

$$A = \frac{\pi}{4}(OD^2 - ID^2) \text{ in}^2$$

$$EA/L = 216 \text{ lb/in}^2 * (\pi/4 (1.25^2 - 0.5^2))/3 \text{ in}$$

$$EA/L = 74.8 \text{ lb/in}$$

$$\mathbf{k = 74.8 \text{ lb/in}}$$

Use this k value to find the expected deflection of the rubber due to the impact of the carriage. The carriage's residual energy was calculated earlier. This energy will be assumed to be distributed equally between the two rubber stoppers.

$$\text{Residual Energy} = RE = 14.2 \text{ ft} - \text{lbs} = 170 \text{ in} - \text{lbs}$$

$$x = \text{deflection of rubber}$$

$$2 * (\frac{1}{2} * k * x^2) = RE$$

$$x = (RE/k)^{(1/2)}$$

$$x = (170 \text{ in} - \text{lbs}/74.8 \text{ lb/in})^{(1/2)}$$

$$x = 1.51 \text{ in}$$

$$\mathbf{F = kx + kx (Two stoppers)}$$

$$\mathbf{F = 2 * 74.8 \text{ lb/in} * 1.51 \text{ in}}$$

$$\mathbf{F = 226 \text{ lbs}}$$

Finding Reactions due to Impact Force

Given:

FBD at Impact

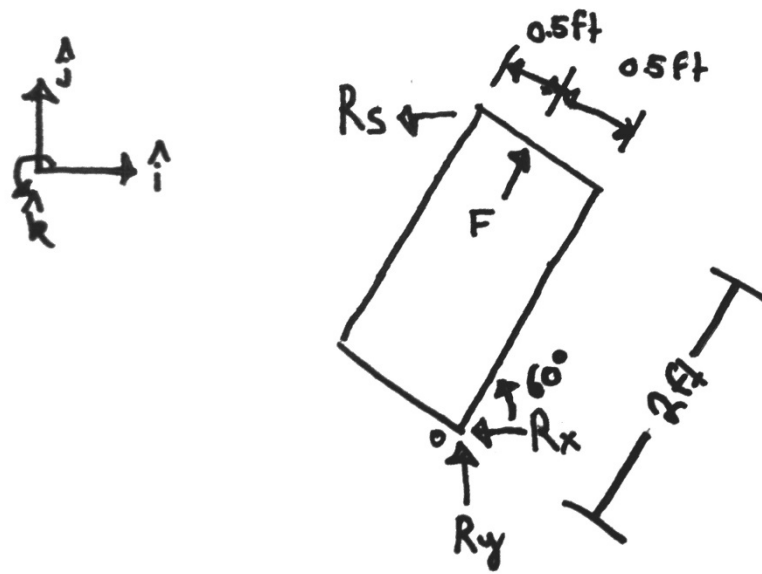

Figure 48. FBD of the frame at impact, with relevant dimensions.

$$F = 226 \text{ lbs}$$

Geometry:

$$(2 \text{ ft} * \sin(60) + 0.5 \text{ ft} * \sin(60))\hat{j} + (2 \text{ ft} * \cos(60) - 0.5 \text{ ft} * \cos(60))\hat{i}$$

$$r_{fo} = 0.75 \text{ ft} \hat{i} + 2.165 \text{ ft} \hat{j}$$

$$r_s = 1 \text{ ft} \hat{i} + 2.6 \text{ ft} \hat{j}$$

Sum of the Moments about Point o:

$$(r_{fo} \times F) + (r_s \times R_s) = 0$$
$$(0.75 \text{ ft } \hat{i} + 2.165 \text{ ft } \hat{j}) \times (226 \text{ lbs} * \cos(60) \hat{i} + 226 \text{ lbs} * \sin(60) \hat{j})$$
$$+ (1 \text{ ft } \hat{i} + 2.6 \text{ ft } \hat{j}) \times R_s \hat{i} = 0$$

$$k: -97.85 \text{ ftlbs} - (2.6 \text{ ft})(R_s) = 0$$

$$R_s = -37.6 \text{ lbs}$$

Sum of the Forces in the X-direction:

$$226 \text{ lbs} * \cos(60) - 37.6 \text{ lbs} - R_x = 0$$

$$R_x = 75.4 \text{ lbs}$$

Sum of the Forces in the Y-direction:

$$226 \text{ lbs} * \sin(60) + R_y = 0$$

$$R_y = 113 \text{ lbs}$$

Friction Between Pull Pin and Carriage

The force to activate the launch is dependent upon the friction between the pull pin and the carriage.

$$Friction = \mu N$$

Where μ is the friction coefficient between the pull pin and the bracket hole, and N is the normal force, which is the same as the static loading right before launch.

μ is 0.16 between steel and bronze when lubricated, according to Engineering Toolbox.

$$N = 65 \text{ lbs}$$

$$Friction = (0.16) * 65 \text{ lbs}$$

$$Friction = 10.4 \text{ lbs}$$

Latex Tubing Energy Storage and Size Selection

Three latex tubing samples were procured and their dimensions are as follows:

Small: 3/8" OD, 1/8" ID

Medium: 9/16" OD, 1/8" ID

Large: 5/8" OD, 1/8" ID

For each, one end was clamped to a static surface and a certain amount of force was applied to the other end, stretching the bands. The results of the tests are shown below:

Table 5. Testing the elastic.

Small		Medium		Large	
Force (lb)	Length (in)	Force (lb)	Length (in)	Force (lb)	Length (in)
0	5.7	0	6.9	0	6.4
5.125	7.3	5	7.7	4.9375	6.8
6.875	9.2	10	8.6	9.9375	7.4
9.9375	10.7	14.875	10.1	14.8125	8.3
11.875	13.9	19.9375	11.7	19.125	9.6
14.6875	15.9	24.9375	14.2	25	10.6
15.1875	17.8	-	-	-	-
17.5625	21.8	-	-	-	-

These results were plotted below to determine the energy curve. The curve can be found below.

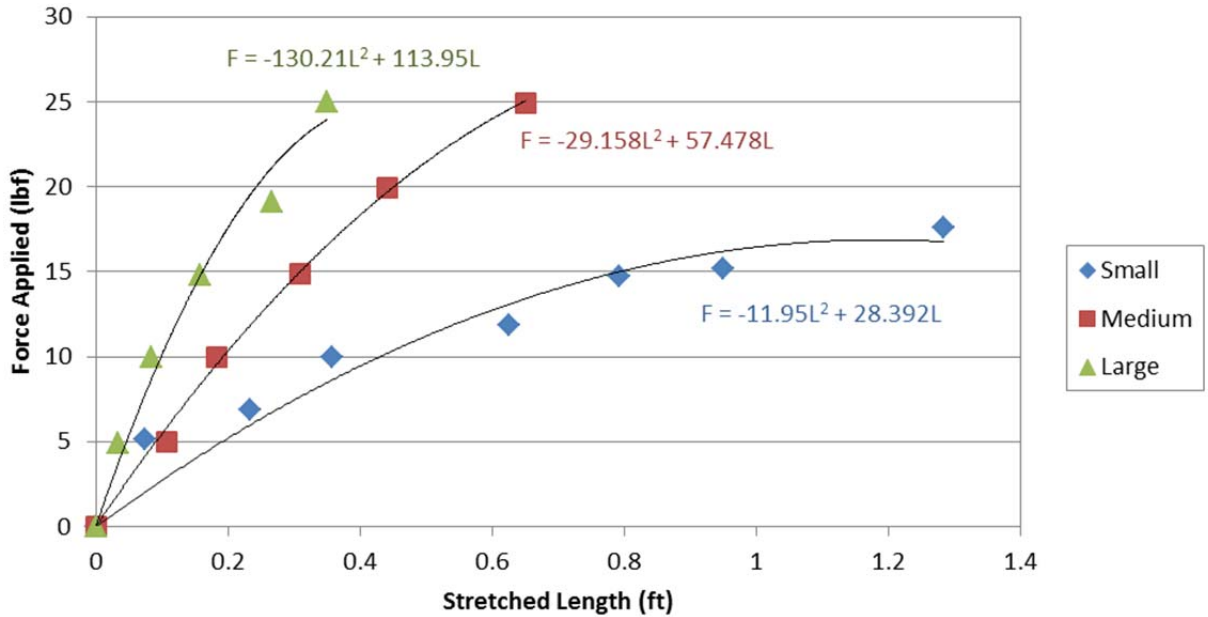

Figure 49. Testing the elastic available to use for launch.

$$Energy = \int Fdl$$

$$E_{small} = \int_0^L -11.95L^2 + 28.392L = -\frac{11.95}{3}L^3 + \frac{28.392}{2}L^2$$

$$E_{medium} = \int_0^L -29.158L^2 + 57.478L = -\frac{29.158}{3}L^3 + \frac{57.478}{2}L^2$$

$$E_{large} = \int_0^L -130.21L^2 + 113.95L = -\frac{130.21}{3}L^3 + \frac{113.95}{2}L^2$$

$$E_{reqd} = 36.3 \text{ ftlb} = 425.6 \text{ inlb}$$

Assuming four elastic bands required:

$$E_{reqd,1band} = \frac{425.6}{4} = 106.4 \text{ inlb}$$

After plugging in and solving for L for each band we get the following:

$$L_{small} = 13.168 \text{ in}$$

$$L_{medium} = 12.058 \text{ in}$$

$$L_{large} = 10.305 \text{ in}$$

Plugging each length value into the curve fit for each band, we can find the force required to stretch one band. Multiplying by the number of bands gives the total static force required.

$$F_{small} = (16.07 \text{ lb})(4) = \mathbf{64.28 \text{ lbf}}$$

$$F_{medium} = (24.72 \text{ lb})(4) = 98.88 \text{ lbf}$$

$$F_{large} = (24.24 \text{ lb})(4) = 96.95 \text{ lbf}$$

The best choice here is the small band because it can provide the energy required in the space we have and requires the lowest amount of force.

Static Analysis of Winch Shaft

We needed to check the strength of our winch shaft to make sure it doesn't deflect under our expected maximum load of **65 lb_f**. A shear-moment diagram of the shaft is shown below:

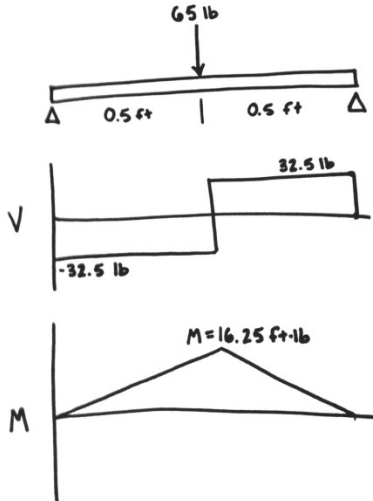

Figure 50. Shear and moment diagram of winch shaft.

$$\sigma = \frac{Mc}{I} = \frac{Mr}{\frac{\pi}{4}r^4} = \frac{4M}{\pi r^3} = \frac{65}{\pi r^3}$$

$$\tau = \frac{4V}{3A} = \frac{4(32.5 \text{ lb})}{3\pi r^2} = \frac{130}{3\pi r^2}$$

$$\tau_{max} = \frac{90000 \text{ lb}}{2} \frac{1}{ft^2} = \sqrt{\left(\frac{\sigma}{2}\right)^2 + \tau^2} = \sqrt{\left(\frac{65}{2\pi r^3}\right)^2 + \left(\frac{130}{3\pi r^2}\right)^2}$$

Solving for r:

$$r_{min} = 0.140 \text{ in}, \quad d_{min} = 0.28 \text{ in}$$

As a result, we have chosen a winch shaft with a 1/2" diameter. The factor safety is as follows:

$$SF = \frac{0.5}{0.28} = \mathbf{1.782}$$

Press Fit Calculations

Sample calculation for ACME Cylinder Nut to Hole

Given: (medium-drive fit use H7/S6 from Shigley)

$$d = D = 0.75 \text{ in}$$

Analysis:

For Hole: IT 7, 0.75 in. basic:

$$\Delta D = 0.0008 \text{ in.}$$

$$D_{max} = 0.7508 \text{ in.}$$

$$D_{min} = 0.7500 \text{ in.}$$

For Nut: IT 6, 0.75 in. basic:

$$\Delta d = 0.0005 \text{ in.}$$

For 0.75 in. basic, $\delta_f = +0.0014 \text{ in}$

$$d_{min} = d + \delta_f = 0.7514 \text{ in}$$

$$d_{max} = d + \delta_f + \Delta d = 0.7519 \text{ in}$$

$$\textbf{Hole: } 0.75 \text{ in } \begin{matrix} +0.0008 \\ -0.0000 \end{matrix}$$

$$\textbf{Nut: } 0.7514 \text{ in } \begin{matrix} +0.0005 \\ -0.0000 \end{matrix}$$

Guide Rod Buckling

Assume guide rods support entirety of static load. Therefore, each rod must support 32.5 pounds force.

$$E_{\text{Steel}} = 30 \times 10^6 \text{ psi}$$

$$d = 0.5 \text{ in}, r = 0.25 \text{ in}$$

$$I = \frac{\pi}{4} r^4 = \frac{\pi}{4} (0.25)^4 = 0.003068 \text{ in}^4$$

$$L = 24 \text{ in}$$

Because the guide rod is attached in two places on each bar of the frame, treat it as a fixed-fixed beam.

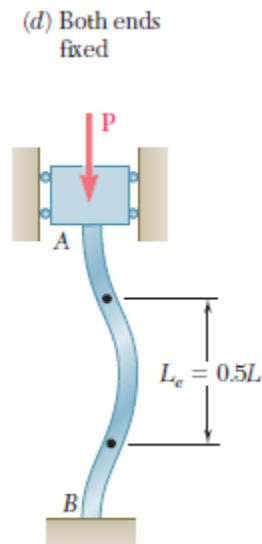

Figure 51. Effective length for a fixed-fixed beam. Image from Beer's Mechanics of Materials, 6th Ed.

$$L_e = 12 \text{ in}$$

The force required to buckle a guide rod in the worst-case scenario is:

$$P_{cr} = \frac{\pi^2 EI}{L_e^2} = \frac{\pi^2 (30 \times 10^6 \text{ psi})(0.003068 \text{ in}^4)}{(12 \text{ in})^2} = \mathbf{6308 \text{ lbf}}$$

$$\text{Safety Factor} = \frac{6308}{32.5} = \mathbf{194}$$

Appendix D – Gantt Chart

The Gantt Chart on the following page shows our team’s expected timeline for the entirety of our project. It was last updated in February. While all tasks were completed on time, we did not complete the tasks in the order listed on the Gantt Chart.

Bolded tasks are large tasks and are shown on the chart as gray bars. Each of the large tasks are broken up into multiple smaller tasks, which are shown on the chart as bright blue bars. Our team’s major due dates are shown as bright blue diamonds. If one task must be finished in order for another to begin, this is shown on the chart via an arrow drawn between the two tasks.

ID	WBS	Task Name	Duration	Start	Finish	Sep 1, '13	Oct 13, '13	Nov 24, '13	Jan 5, '14	Feb 16, '14	Mar 30, '14	May 11, '14	Jun 22, '14				
						S	T	M	F	T	S	W	S	T	M	F	T
1	1	Choose Project	5 days	Tue 9/24/13	Mon 9/30/13												
5	2	Meet Team and Sponsor	11 days	Tue 10/1/13	Tue 10/15/13												
12	3	Define Problem	26 days	Thu 10/3/13	Thu 11/7/13												
18	4	Conceptualize Solutions	26 days	Thu 10/24/13	Thu 11/28/13												
23	5	Choose a Solution	10 days	Fri 11/15/13	Thu 11/28/13												
28	6	Prepare Conceptual Design Review	8 days	Thu 11/28/13	Mon 12/9/13												
33	7	Detail Design	44 days	Mon 12/9/13	Thu 2/6/14												
34	7.1	Conduct Elastic Band Testing	8 days	Tue 1/7/14	Thu 1/16/14												
35	7.2	Conduct Engineering Analysis	8 days	Fri 1/17/14	Tue 1/28/14												
36	7.3	Compile Final Bill of Materials	39 days	Mon 12/9/13	Thu 1/30/14												
37	7.4	Create Detailed CAD Model and Part Drawings	44 days	Mon 12/9/13	Thu 2/6/14												
38	7.5	Develop Test Plan	6 days	Thu 1/23/14	Thu 1/30/14												
39	8	Prepare Critical Design Review	8 days	Tue 1/28/14	Thu 2/6/14												
40	8.1	Write Critical Design Report	9 days	Fri 2/7/14	Wed 2/19/14												
41	8.2	Practice CDR	3 days	Tue 1/28/14	Thu 1/30/14												
42	8.3	Critical Design Review with Sponsor	0 days	Thu 2/6/14	Thu 2/6/14												
43	8.4	Critical Design Report Due	0 days	Mon 2/10/14	Mon 2/10/14												
44	9	Manufacture	53 days	Thu 1/30/14	Sun 4/13/14												
45	9.1	Order Supplies	20 days	Fri 1/31/14	Thu 2/27/14												
46	9.2	Outsource Carriage Cuts	11 days	Thu 2/20/14	Thu 3/6/14												
47	9.3	Weld Hinge Ass'y	6 days	Tue 2/11/14	Tue 2/18/14												
48	9.4	Build Lower Frame Ass'y	6 days	Tue 2/18/14	Tue 2/25/14												
49	9.5	Build Pawl Block Ass'y	3 days	Tue 2/25/14	Thu 2/27/14												
50	9.6	Build Winch Shaft Ass'y	8 days	Tue 2/25/14	Thu 3/6/14												
51	9.7	Build Carriage Ass'y	6 days	Thu 3/6/14	Thu 3/13/14												
52	9.8	Build Frame Ass'y	6 days	Thu 3/13/14	Thu 3/20/14												
53	9.9	Build Ratchet Arm Ass'y	4 days	Thu 3/20/14	Tue 3/25/14												
54	9.10	Weld Table Top Ass'y	3 days	Tue 3/25/14	Thu 3/27/14												
55	9.11	Build Aiming Ass'y	6 days	Thu 3/27/14	Thu 4/3/14												
56	9.12	Assemble Full Mechanism	6 days	Thu 4/3/14	Thu 4/10/14												
57	10	Prepare for Manufacturing and Test Review	10 days	Tue 2/18/14	Mon 3/3/14												
58	11	Manufacturing and Test Review	0 days	Tue 3/4/14	Tue 3/4/14												
59	12	Project Update Memo Due	0 days	Tue 3/11/14	Tue 3/11/14												
60	13	Project Assembled	0 days	Thu 4/10/14	Thu 4/10/14												
61	14	Test	22 days	Mon 4/14/14	Tue 5/13/14												
62	14.1	Test in Controlled Environment	11 days	Mon 4/14/14	Sun 4/27/14												
63	14.2	Project Hardware/Assembly Demo	0 days	Mon 4/28/14	Mon 4/28/14												
64	15	Test with Friday Club	11 days	Mon 4/28/14	Mon 5/12/14												
65	16	Adjust Design as Necessary	21 days	Mon 4/14/14	Sun 5/11/14												
66	17	Project Completely Manufactured in Final Form	0 days	Tue 5/13/14	Tue 5/13/14												
67	18	Prepare for Design Expo	13 days	Thu 5/15/14	Sat 5/31/14												
68	18.1	Make Presentation Board	15 days	Tue 5/13/14	Sat 5/31/14												
69	18.2	Practice for Expo	13 days	Thu 5/15/14	Sat 5/31/14												
70	18.3	Senior Project Design Expo	0 days	Sat 5/31/14	Sat 5/31/14												
71	19	Write Final Report	17 days	Thu 5/15/14	Fri 6/6/14												
72	19.1	Polish CAD Model	12 days	Thu 5/15/14	Fri 5/30/14												
73	19.2	Update Text	17 days	Thu 5/15/14	Fri 6/6/14												
74	19.3	Final Report Due	0 days	Fri 6/6/14	Fri 6/6/14												

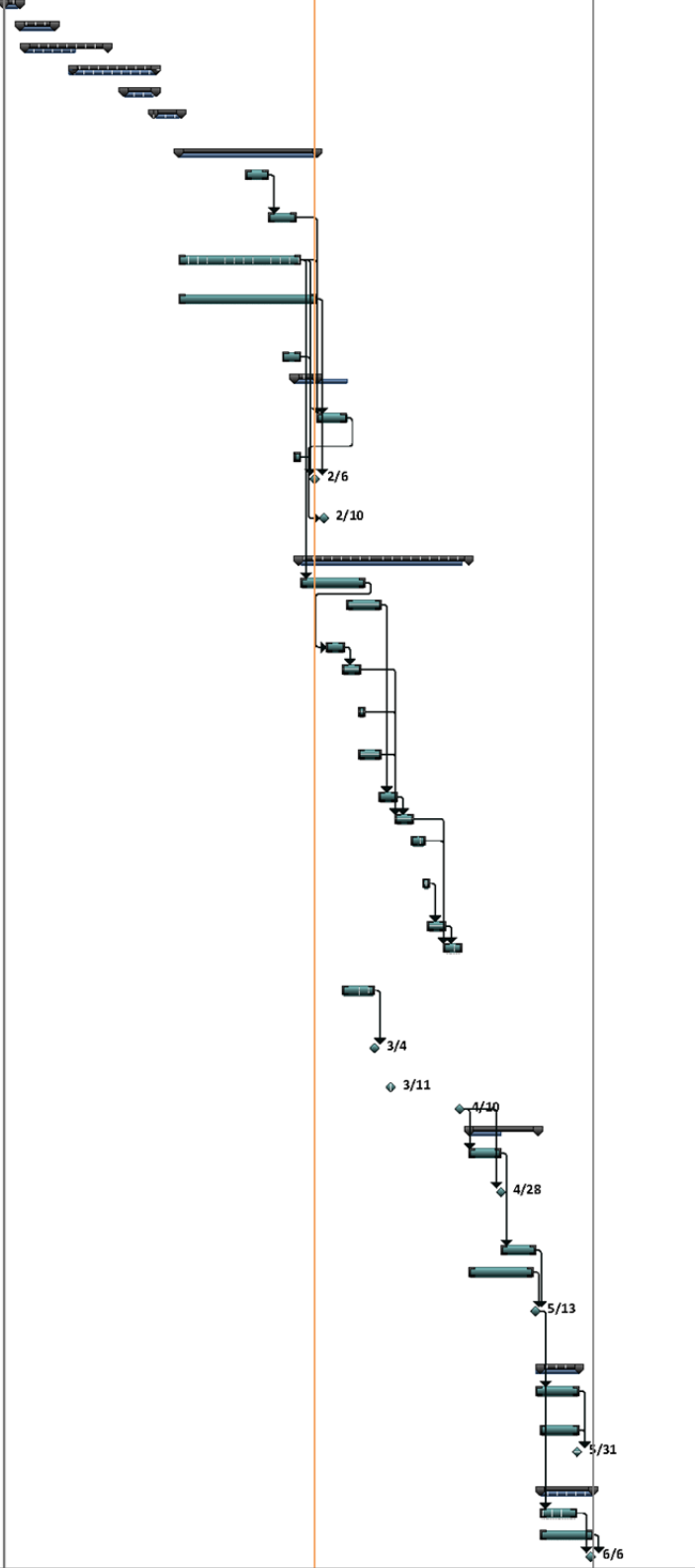

Appendix E – Drawing Packets

The following pages contain part drawings of all parts that our team must either alter or manufacture from scratch. The information in these drawings are meant to provide enough detail that an outsider can build our basketball shooter with no external information. Additionally, assembly drawings are given to show how all parts, both manufactured and purchased off the shelf, are assembled to give the finished product.

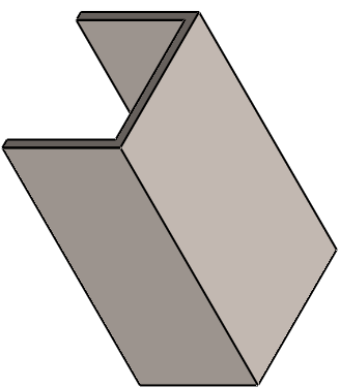

ISOMETRIC SCALE 1:2

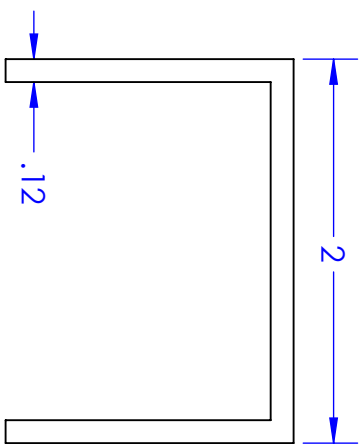
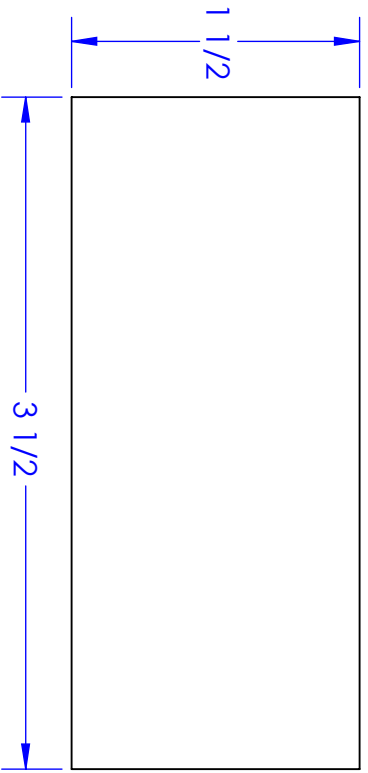

UNLESS OTHERWISE SPECIFIED:

DIMENSIONS ARE IN INCHES
 TOLERANCES:
 FRACTIONAL: +1/32
 TWO PLACE DECIMAL: ±0.015
 THREE PLACE DECIMAL: ±0.005

WEIGHT: 0.55 LB

MATERIAL: ALLOY STEEL

FINISH: N/A

DO NOT SCALE DRAWING

DRAWN	BRETT NAVUDU
DATE	06/02/2014
CHECKED	JENNA BECKER
DATE	06/02/2014
COMMENTS:	

N/A

SCALE: 1:1

TITLE:

UPF BASE ATTACHMENT

SIZE	DWG. NO.	REV
A	BH101	1
NEXT ASSY: LF001		SHEET 1 OF 1

Mechanical Engineering
 SolidWorks Student Edition.
 For Academic Use Only.

ADAPTIVE BASKETBALL SHOOTER

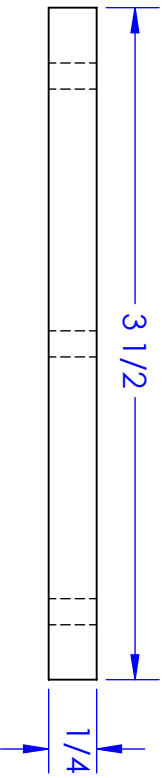
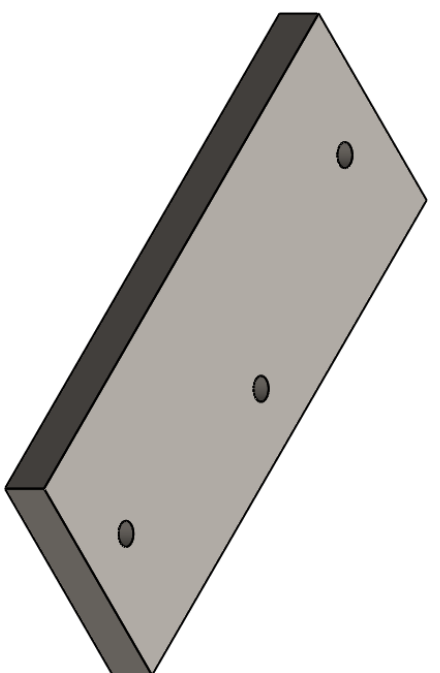
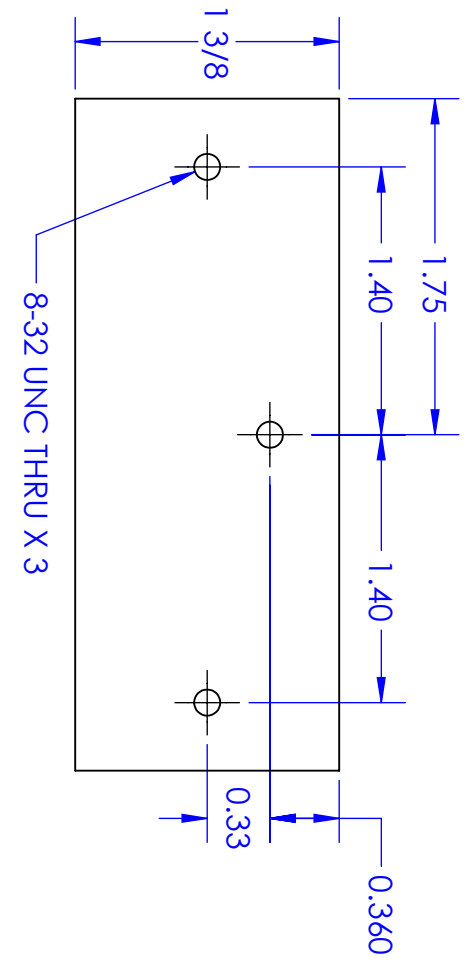

UNLESS OTHERWISE SPECIFIED:

DIMENSIONS ARE IN INCHES
TOLERANCES:
FRACTIONAL: +1/32
TWO PLACE DECIMAL: ±0.015
THREE PLACE DECIMAL: ±0.005

WEIGHT: 0.34 LB

MATERIAL: 1023 CARBON STEEL

FINISH: N/A

DO NOT SCALE DRAWING

DRAWN	BRETT NAVYUDU
DATE	02/06/2014
CHECKED	JENNA BECKER
DATE	02/06/2014

COMMENTS:

N/A

SCALE: 1:1

TITLE:

HINGE ADAPTER

SIZE DWG. NO. **A** BH102

REV **0**

NEXT ASSY.: LF001

SHEET 1 OF 1



ADAPTIVE BASKETBALL SHOOTER

5

4

3

2

1

ITEM NO.	PART NUMBER	DESCRIPTION	QTY.
1	BH101	UPF BASE ATTACHMENT	1
2	BH102	HINGE ADAPTER	1
3	1502A21	BASE HINGE	1

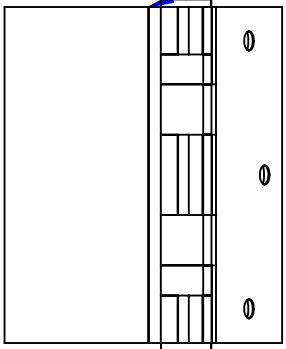
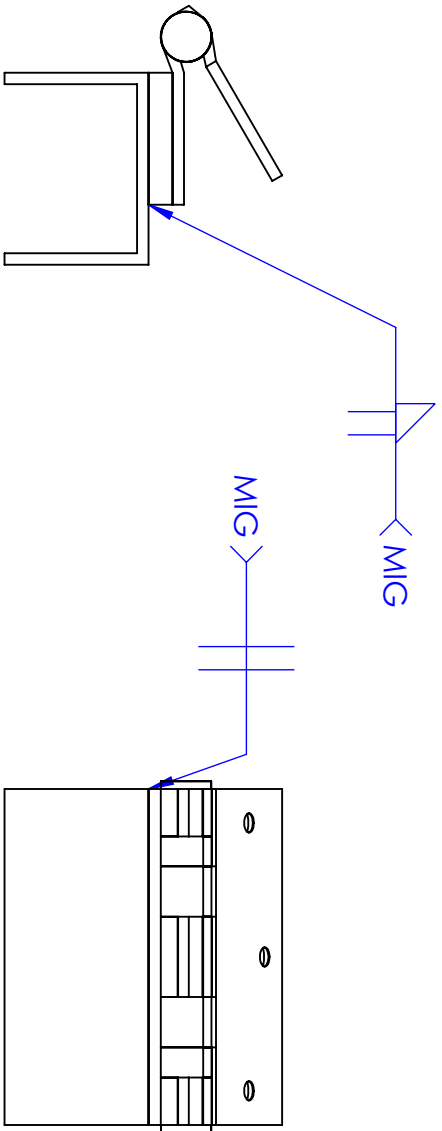
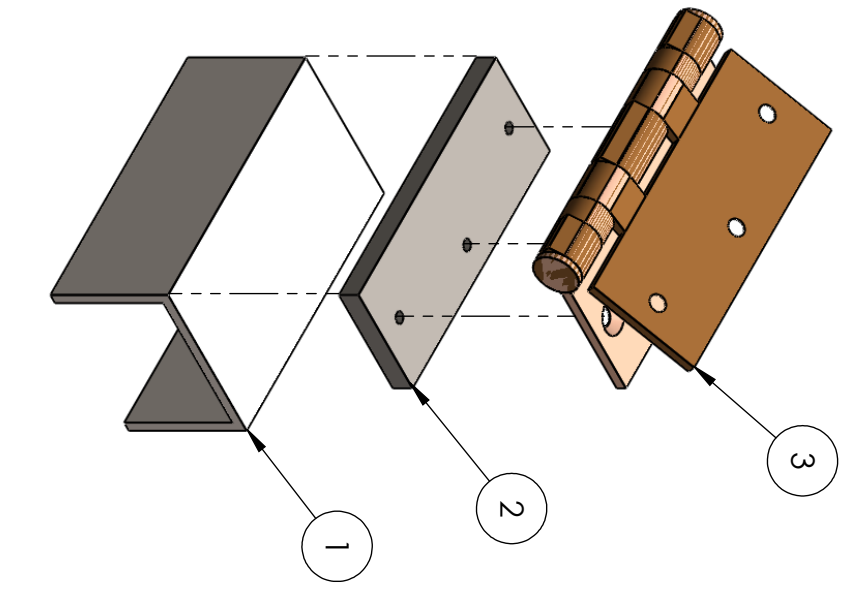

UNLESS OTHERWISE SPECIFIED:

DIMENSIONS ARE IN INCHES
 TOLERANCES:
 FRACTIONAL: +1/32
 TWO PLACE DECIMAL: ±0.015
 THREE PLACE DECIMAL: ±0.005

WEIGHT 1.65 LB

MATERIAL VARIOUS

FINISH NONE

DO NOT SCALE DRAWING

DRAWN	JENNA BECKER
DATE	06/02/2014
CHECKED	RICHARD GALANTI
DATE	06/02/2014

COMMENTS:

HINGE ADAPTER IS MIG WELDED TO UPF BASE ATTACHMENT. BASE HINGE IS BOLTED ONTO THE HINGE ADAPTER

TITLE:

BOTTOM HINGE ASSEMBLY

SIZE	DWG. NO.	REV
A	LF001	1

NEXT ASSY: FA001 SHEET 1 OF 1

Mechanical Engineering
 Solidworks Student Edition.
 For Academic Use Only.

ADAPTIVE BASKETBALL SHOOTER

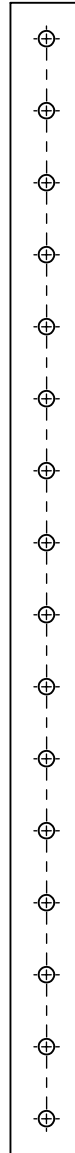
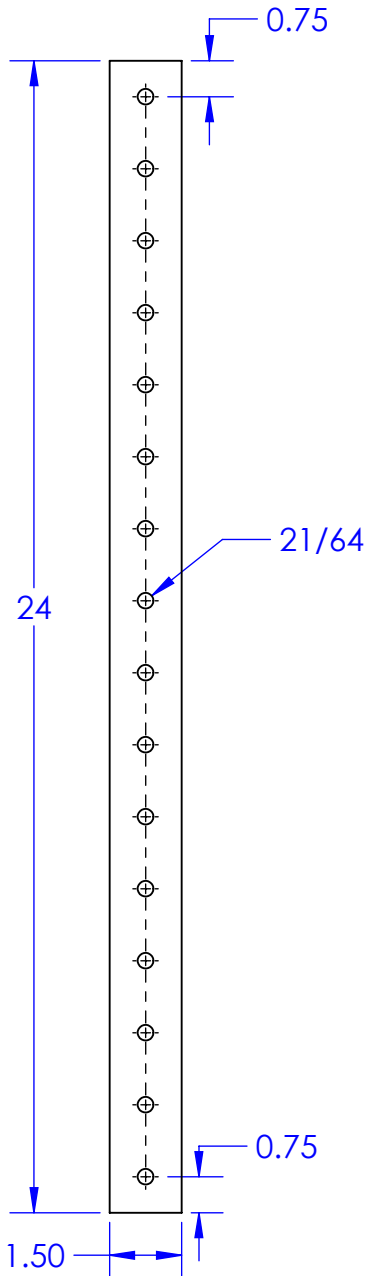
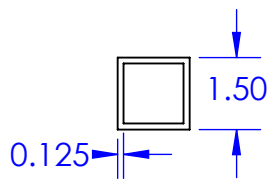

DIMENSIONS ARE IN INCHES
 TOLERANCES:
 FRACTIONAL: $\pm 1/32$
 TWO PLACE DECIMAL: ± 0.015
 THREE PLACE DECIMAL: ± 0.005

WEIGHT	1.54 LB
MATERIAL	ALUMINUM
FINISH	N/A
DO NOT SCALE DRAWING	

DRAWN	RICHARD GALANTI
DATE	02/06/2014
CHECKED	BRETT NAYUDU
DATE	02/06/2014
COMMENTS: STOCK COMES WITH HOLES PRE-DRILLED. MUST ONLY BE CUT TO LENGTH.	

TITLE:		LONG FRAME MEMBER	
SIZE	DWG. NO.	REV.	
A	LF101	0	
SCALE: 1:4	NEXT ASSY: FA001	SHEET 1 OF 1	

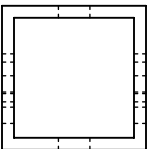
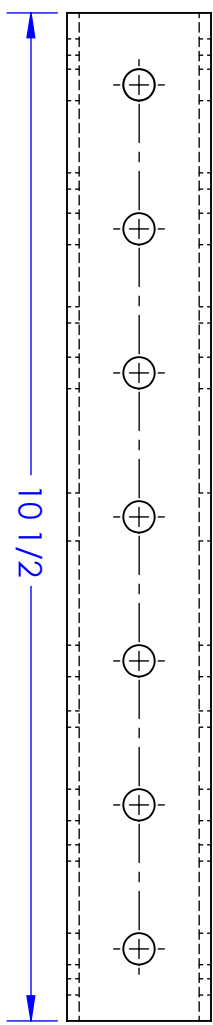
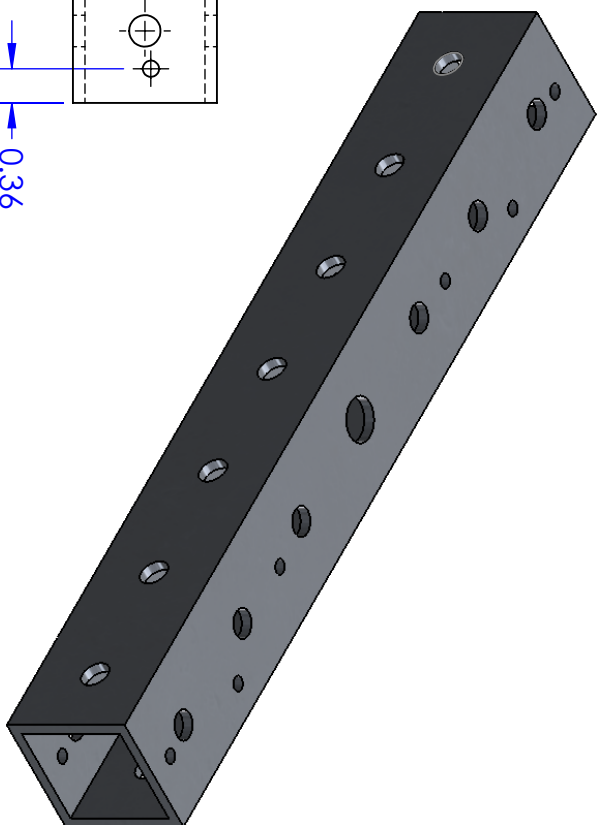
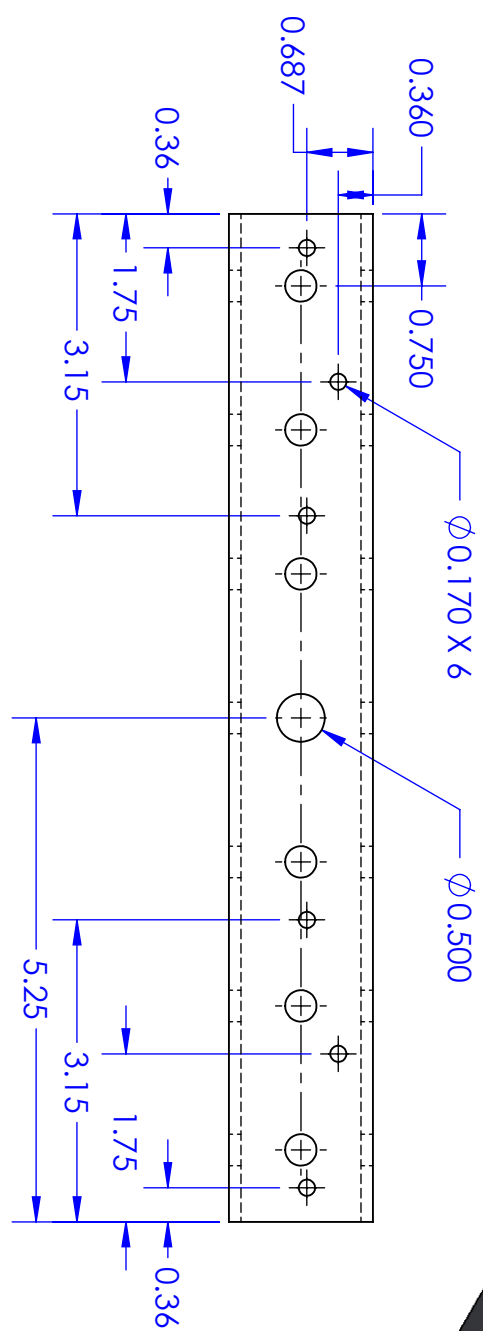

UNLESS OTHERWISE SPECIFIED:

DIMENSIONS ARE IN INCHES
 TOLERANCES:
 FRACTIONAL $\pm 1/32$
 TWO PLACE DECIMAL ± 0.015
 THREE PLACE DECIMAL ± 0.005

WEIGHT 0.669 lbs

MATERIAL ALUMINUM

FINISH N/A

DO NOT SCALE DRAWING

DRAWN RICHARD GALANTI

DATE 2/5/14

CHECKED BRETT NAYUDU

DATE 2/6/14

COMMENTS:
 MADE FROM ALUMINUM BOLT
 TOGETHER FRAMING,
 HOLES NOT DIMENSIONED ARE
 PRE-EXISTING

TITLE:

BOTTOM FRONT
 FRAME MEMBER

SIZE DWG. NO. LF102

NEXT ASSY: FA001

SHEET 1 OF 1

REV 0

Mechanical Engineering
 SolidWorks Student Edition.
 For Academic Use Only.

ADAPTIVE BASKETBALL SHOOTER

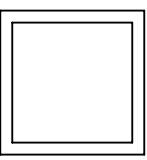
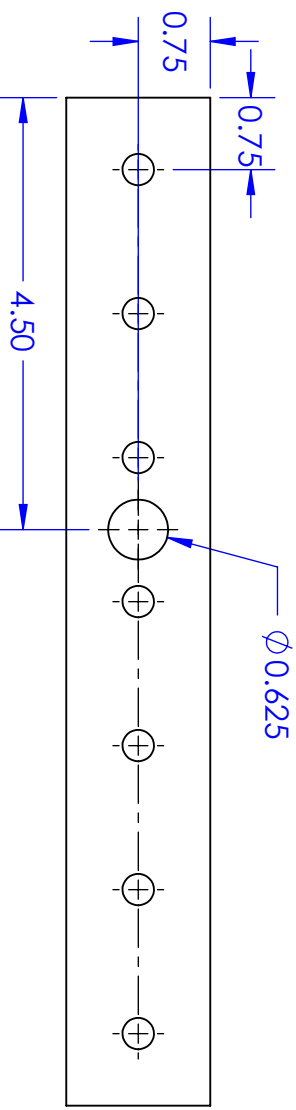
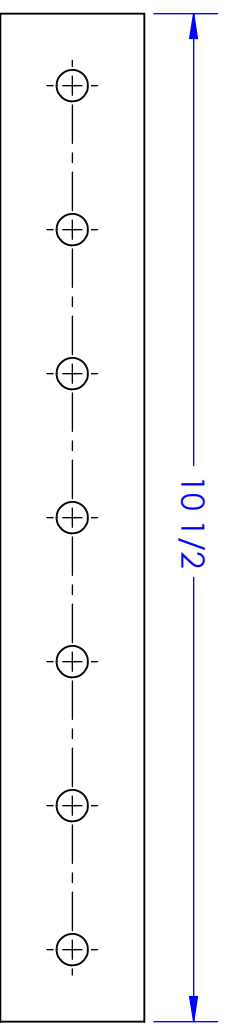

UNLESS OTHERWISE SPECIFIED:

DIMENSIONS ARE IN INCHES
 TOLERANCES:
 FRACTIONAL: +1/32
 TWO PLACE DECIMAL: ±0.015
 THREE PLACE DECIMAL: ±0.005

WEIGHT: 0.668 LB

MATERIAL: ALUMINUM

FINISH: N/A

DO NOT SCALE DRAWING

DRAWN: RICHARD GALANTI
 DATE: 02/05/2014

CHECKED: BRETT NAYUDU
 DATE: 02/06/2014

COMMENTS:

DIMENSIONS THAT ARE NOT LABELED ARE THE STOCK VALUES

SCALE: 1:2

TITLE:

BOTTOM SIDE FRAME MEMBER

SIZE: **A**
 DWG. NO.: LF103

NEXT ASSY: XXXX

REV: **0**

SHEET 1 OF 1

Mechanical Engineering
 Solidworks Student Edition.
 For Academic Use Only.

ADAPTIVE BASKETBALL SHOOTER

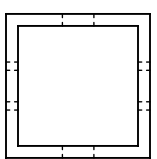
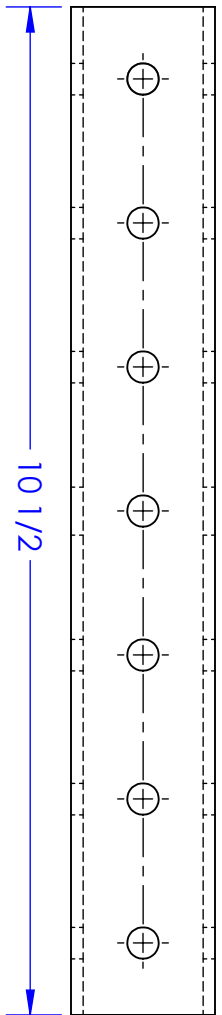
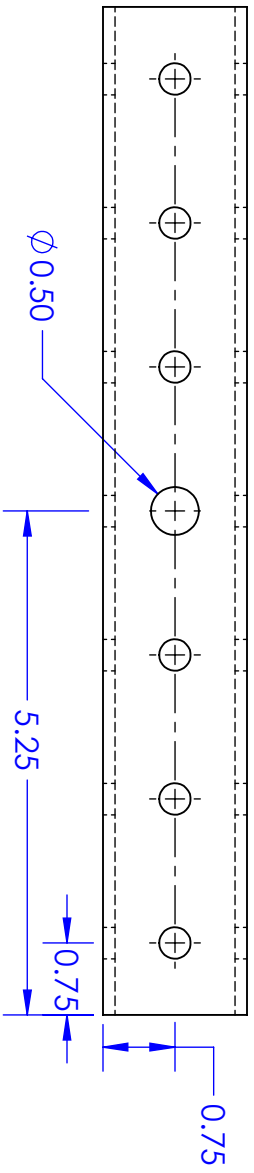
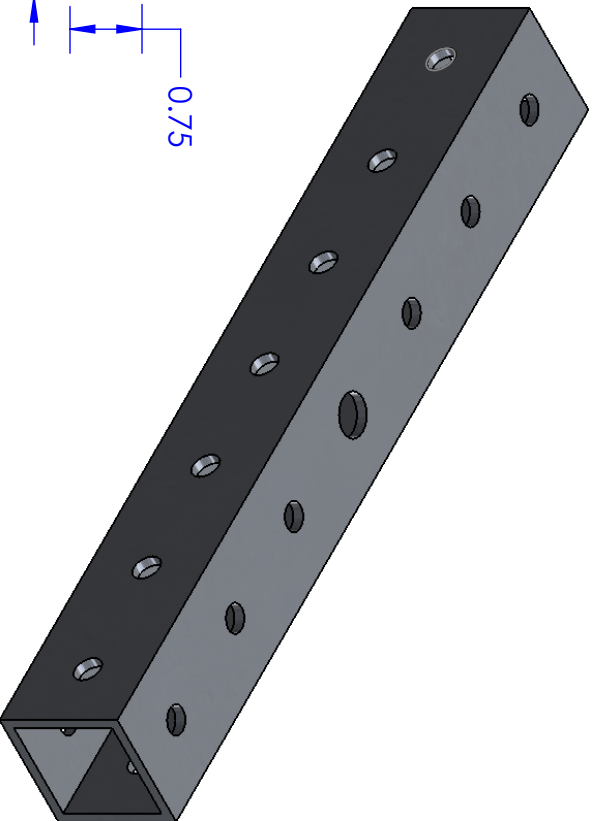

UNLESS OTHERWISE SPECIFIED:

DIMENSIONS ARE IN INCHES	DRAWN	RICHARD GALANTI
TOLERANCES:	DATE	02/05/2014
FRACTIONAL: +1/32	CHECKED	BRETT NAYUDU
TWO PLACE DECIMAL: ±0.015	DATE	02/06/2014
THREE PLACE DECIMAL: ±0.005	COMMENTS:	

TITLE: **BOTTOM REAR FRAME MEMBER**

Mechanical Engineering
Solidworks Student Edition.
For Academic Use Only.

ADAPTIVE BASKETBALL SHOOTER

WEIGHT	0.673 lbs	SCALE: 1:2	SIZE	DWG. NO.	REV
MATERIAL	ALUMINUM		A	LF104	0
FINISH	N/A		N/A		
DO NOT SCALE DRAWING			NEXT ASSY: FA001	SHEET 1 OF 1	

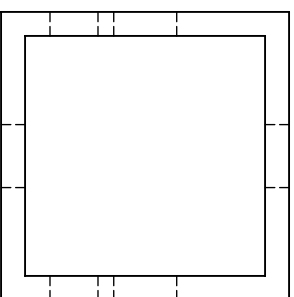
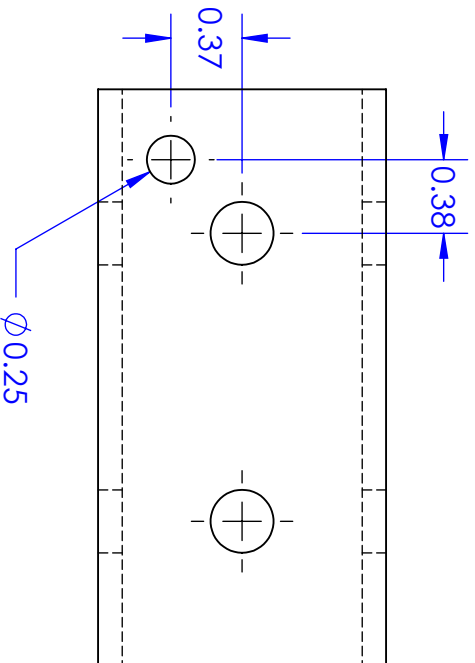
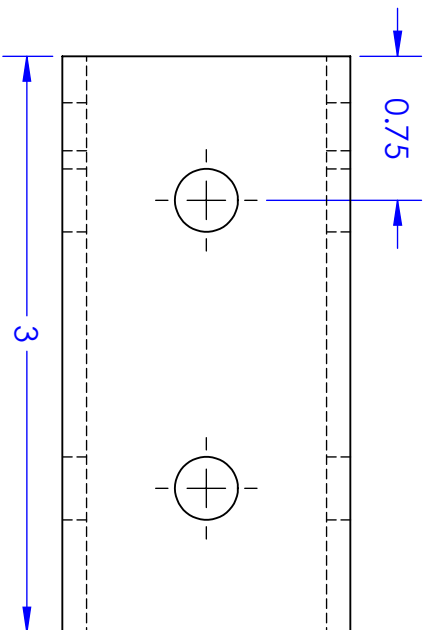
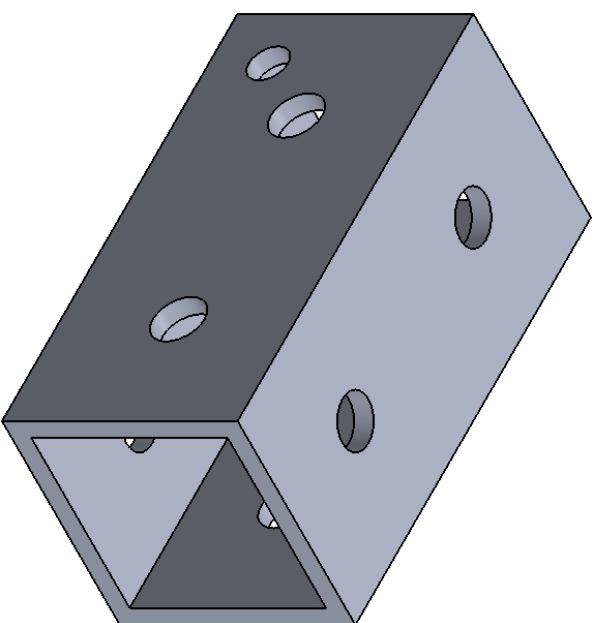

UNLESS OTHERWISE SPECIFIED:

DIMENSIONS ARE IN INCHES
 TOLERANCES:
 FRACTIONAL: +1/32
 TWO PLACE DECIMAL: ±0.015
 THREE PLACE DECIMAL: ±0.005

WEIGHT 0.19LB

MATERIAL ALUMINUM

FINISH N/A

DO NOT SCALE DRAWING

DRAWN BRETT NAVYUDU

DATE 2/6/14

CHECKED XXXXXX

DATE XXXXXX

COMMENTS:

CUT FROM SAME STOCK AS ALL FRAME MEMBERS

TITLE:

PAWL BLOCK

SIZE DWG. NO.

A PB101

REV

0

NEXT ASSY: FA002

SHEET 1 OF 1

Mechanical Engineering
 SolidWorks Student Edition.
 For Academic Use Only.

ADAPTIVE BASKETBALL SHOOTER

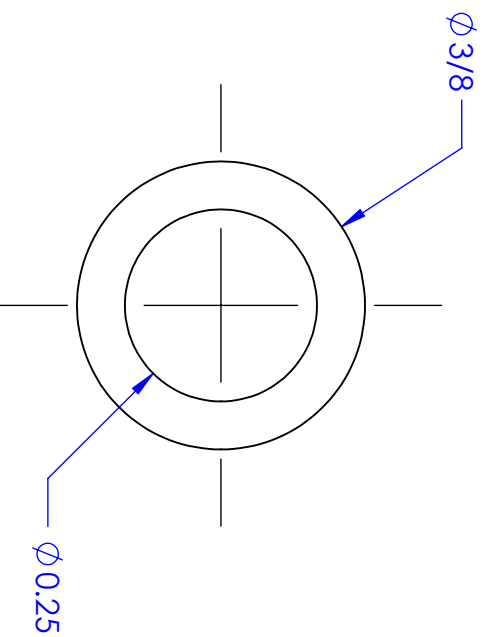
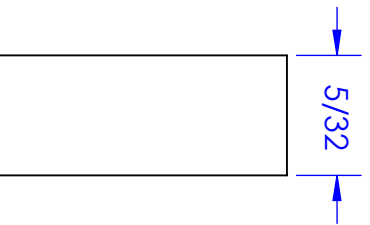
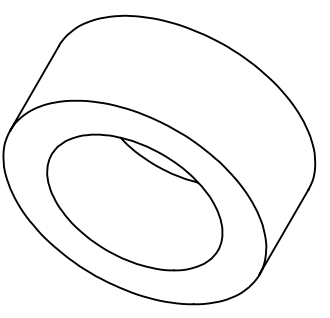

UNLESS OTHERWISE SPECIFIED:

DIMENSIONS ARE IN INCHES
 TOLERANCES:
 FRACTIONAL: +1/32
 TWO PLACE DECIMAL: ±0.015
 THREE PLACE DECIMAL: ±0.005

WEIGHT: NEGLIGIBLE

MATERIAL: DELRIN

FINISH: N/A

DO NOT SCALE DRAWING

DRAWN: RICHARD GALANTI

DATE: 06/03/2014

CHECKED: BRETT NAYUDU

DATE: 06/03/2014

COMMENTS:

N/A

SCALE: 4:1

TITLE:

PAWL SPACER

SIZE: **A**

DWG. NO.: PB102

REV: 1

NEXT ASSY: FA002

SHEET 1 OF 1



ADAPTIVE BASKETBALL SHOOTER

5

4

3

2

1

ITEM NO.	PART NUMBER	DESCRIPTION	QTY.
1	PB101	PAWL BLOCK	1
2	91257A552	1/4-20 X 2.5 BOLT	1
3	6283K32	PAWL	1
4	PB102	PAWL SPACER	1
5	90630A110	1/4-20 LOCKNUT	1

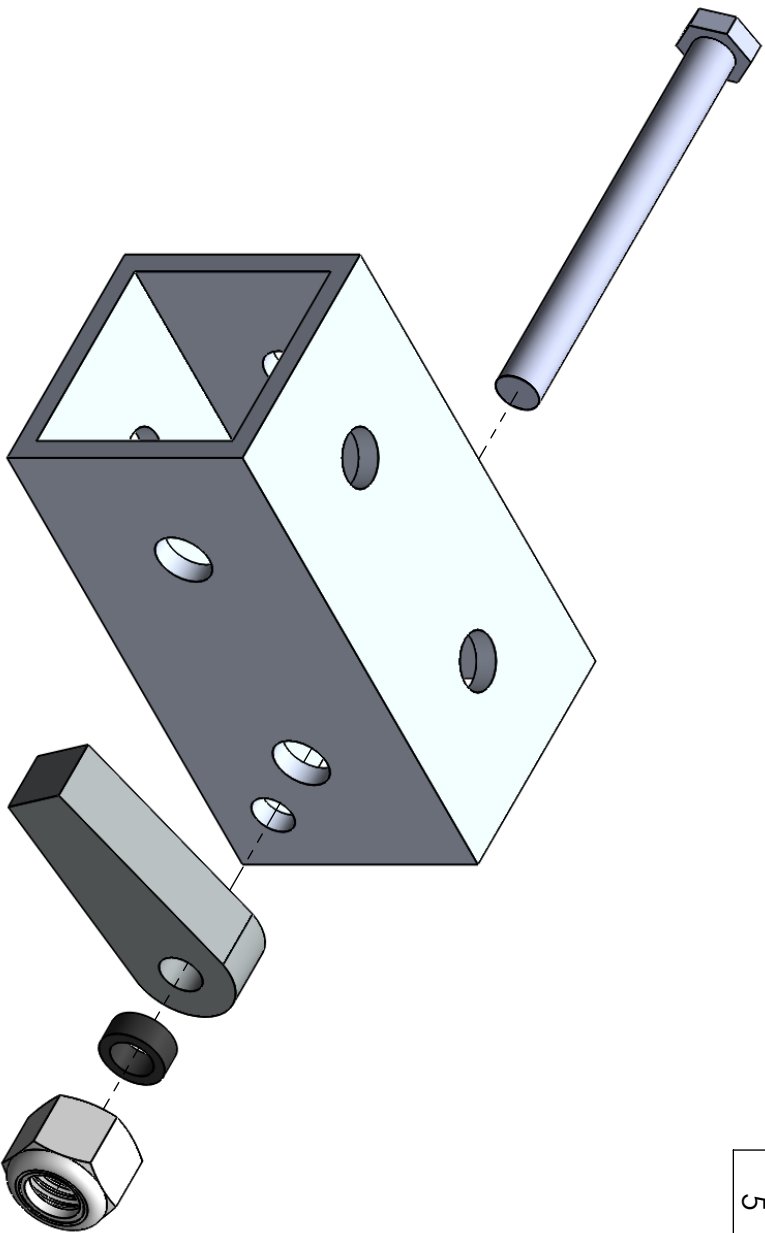

UNLESS OTHERWISE SPECIFIED:

DIMENSIONS ARE IN INCHES
 TOLERANCES:
 FRACTIONAL: +1/32
 TWO PLACE DECIMAL: ±0.015
 THREE PLACE DECIMAL: ±0.005

WEIGHT 0.295 LB

MATERIAL N/A

FINISH N/A

DO NOT SCALE DRAWING

DRAWN	JENNA BECKER
DATE	06/03/2014
CHECKED	RICHARD GALANTI
DATE	06/03/2014

COMMENTS:

N/A

SCALE: 1:1

TITLE:

PAWL BLOCK ASSEMBLY

SIZE DWG. NO. REV
A FA002 **1**

NEXT ASSY: XXXX

SHEET 1 OF 1



ADAPTIVE BASKETBALL SHOOTER

5

4

3

2

1

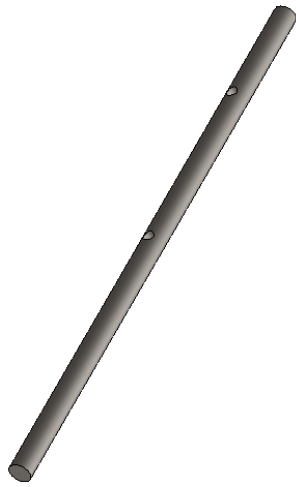

ISOMETRIC SCALE 1:4

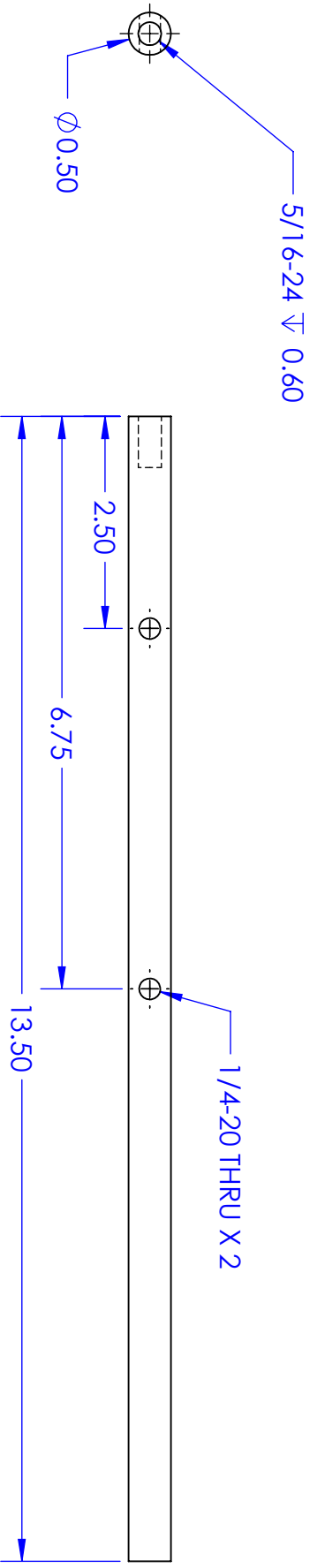

UNLESS OTHERWISE SPECIFIED:

DIMENSIONS ARE IN INCHES
TOLERANCES:
FRACTIONAL: +1/32
TWO PLACE DECIMAL: ±0.015
THREE PLACE DECIMAL: ±0.005

WEIGHT 0.72 LB

MATERIAL 303 STAINLESS STEEL

FINISH N/A

DO NOT SCALE DRAWING

DRAWN JENNA BECKER
DATE 06/03/2014

CHECKED RICHARD GALANTI
DATE 06/03/2014

COMMENTS:

N/A

SCALE: 1:2

TITLE:

WINCH SHAFT

SIZE DWG. NO. WS101

A

NEXT ASSY: FA003

REV

1

SHEET 1 OF 1



ADAPTIVE BASKETBALL SHOOTER

5

4

3

2

1



ISOMETRIC SCALE: 1:2

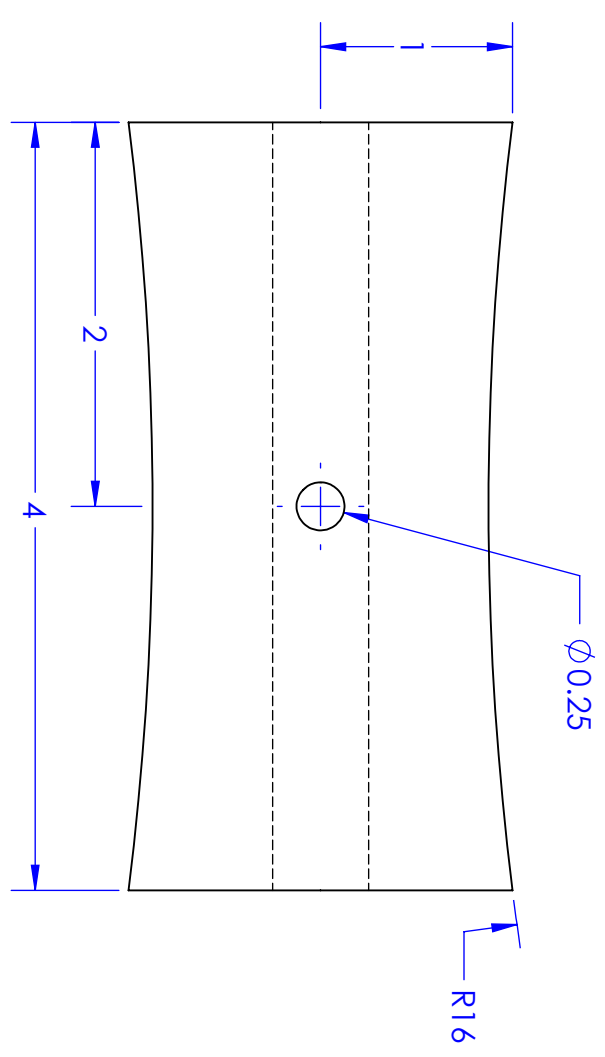
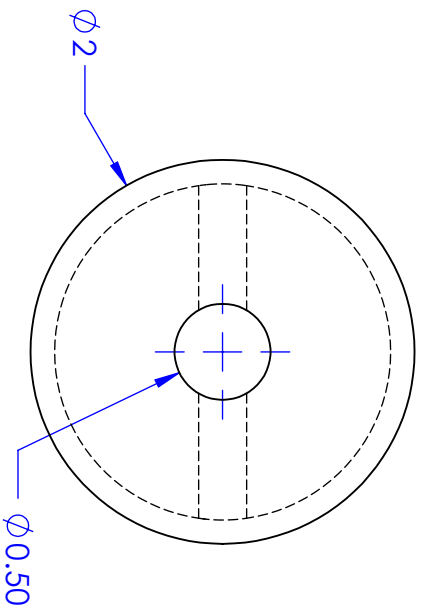

UNLESS OTHERWISE SPECIFIED:

DIMENSIONS ARE IN INCHES
 TOLERANCES:
 FRACTIONAL $\pm 1/32$
 TWO PLACE DECIMAL ± 0.015
 THREE PLACE DECIMAL ± 0.005

WEIGHT 0.165 LB

MATERIAL RED OAK

FINISH N/A

DO NOT SCALE DRAWING

DRAWN		JENNA BECKER	
DATE		02/06/2014	
CHECKED		RICHARD GALANTI	
DATE		02/06/2014	

COMMENTS:
 CREATE TAPER BY SANDING
 DOWN MATERIAL.

SCALE: 1:1

TITLE:

SPOOL

SIZE DWG. NO.
A WS102

NEXT ASSY: FA003

REV
0

SHEET 1 OF 1



ADAPTIVE BASKETBALL SHOOTER

5

4

3

2

1

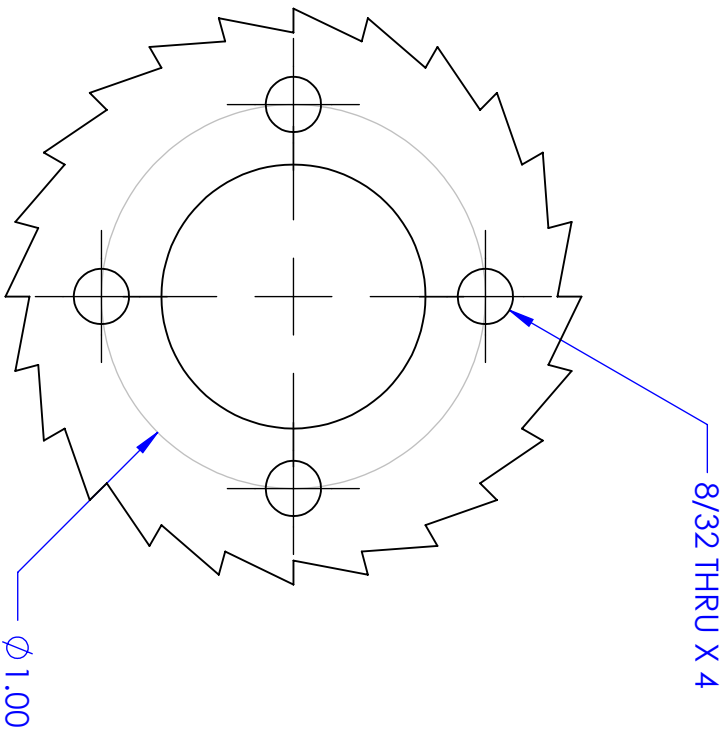
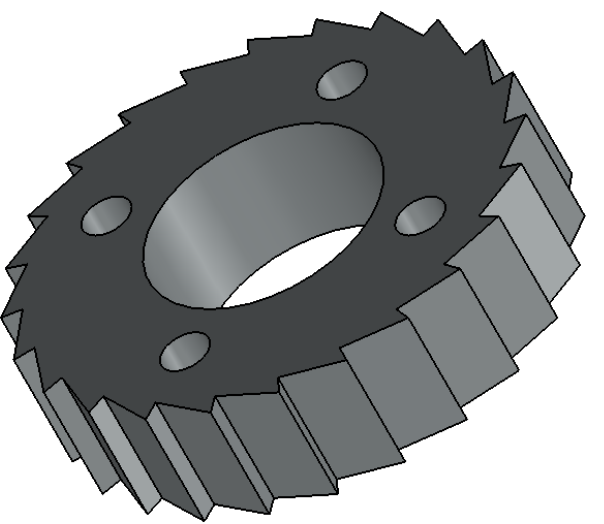

UNLESS OTHERWISE SPECIFIED:

DIMENSIONS ARE IN INCHES
 TOLERANCES:
 FRACTIONAL +1/32
 TWO PLACE DECIMAL ±0.015
 THREE PLACE DECIMAL ±0.005

WEIGHT 0.14 LB

MATERIAL 303 STAINLESS STEEL
 FINISH N/A

DO NOT SCALE DRAWING

DRAWN	RICHARD GALANTI
DATE	02/06/2014
CHECKED	BRETT NAYUDU
DATE	02/07/2014

COMMENTS:

RATCHET GEAR BOUGHT. HOLES ARE THE ONLY ALTERATION MADE

SCALE: 2:1

TITLE:

RATCHET GEAR

SIZE	DWG. NO.	REV
A	WS103	0

NEXT ASSY: FA003 SHEET 1 OF 1



ADAPTIVE BASKETBALL SHOOTER

5

4

3

2

1

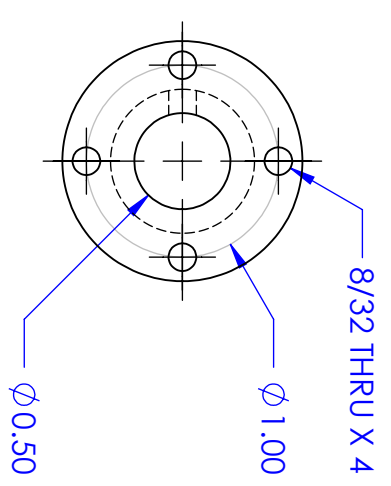
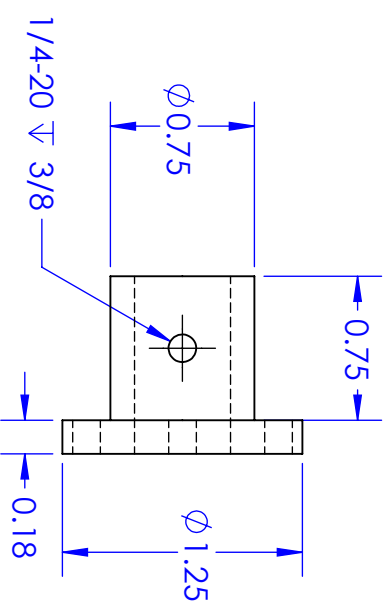
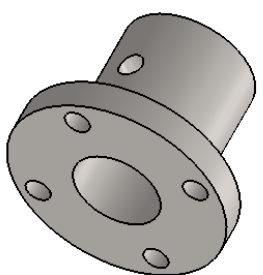

UNLESS OTHERWISE SPECIFIED:

DIMENSIONS ARE IN INCHES
 TOLERANCES:
 FRACTIONAL: +1/32
 TWO PLACE DECIMAL: ±0.015
 THREE PLACE DECIMAL: ±0.005

WEIGHT: 0.099 LB

MATERIAL: 1144 CARBON STEEL

FINISH: N/A

DO NOT SCALE DRAWING

DRAWN	RICHARD GALANTI
DATE	06/03/2014
CHECKED	BRETT NAYUDU
DATE	06/03/2014
COMMENTS:	

N/A

SCALE: 1:1

TITLE:
RATCHET FLANGE

SIZE	DWG. NO.	REV
A	WS104	1

NEXT ASSY: FA003 SHEET 1 OF 1



ADAPTIVE BASKETBALL SHOOTER

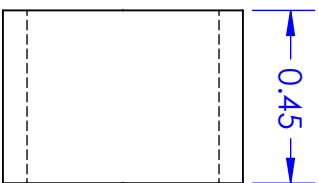
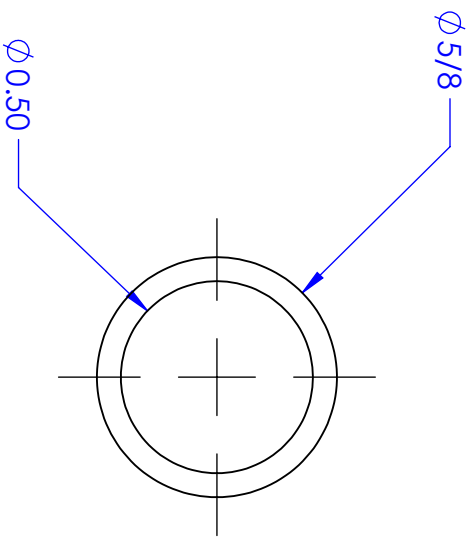
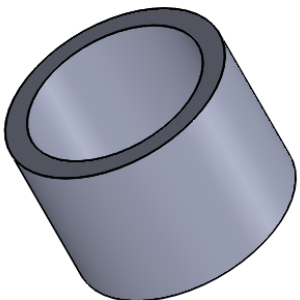

UNLESS OTHERWISE SPECIFIED:

DIMENSIONS ARE IN INCHES
 TOLERANCES:
 FRACTIONAL: +1/32
 TWO PLACE DECIMAL: ±0.015
 THREE PLACE DECIMAL: ±0.005

WEIGHT 0.003 LB

MATERIAL DELRIN

FINISH N/A

DO NOT SCALE DRAWING

DRAWN	JENNA BECKER
DATE	06/03/2014
CHECKED	RICHARD GALANTI
DATE	06/03/2014
COMMENTS:	

N/A

SCALE: 2:1

TITLE:

RATCHET SPACER

SIZE	DWG. NO.	REV
A	WS105	0

NEXT ASSY: FA003

SHEET 1 OF 1



CAL POLY

ADAPTIVE BASKETBALL SHOOTER

5

4

3

2

1

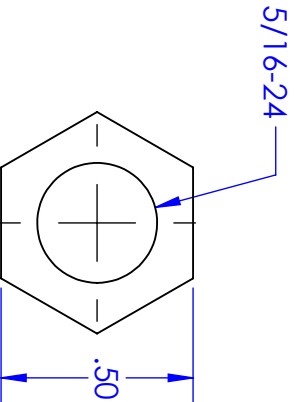
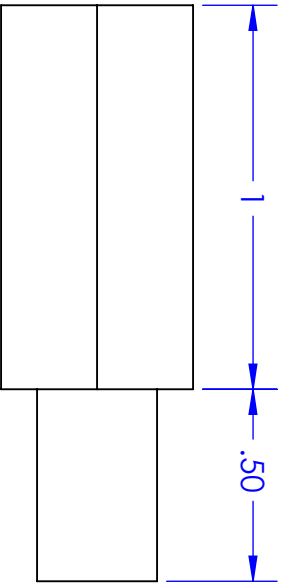
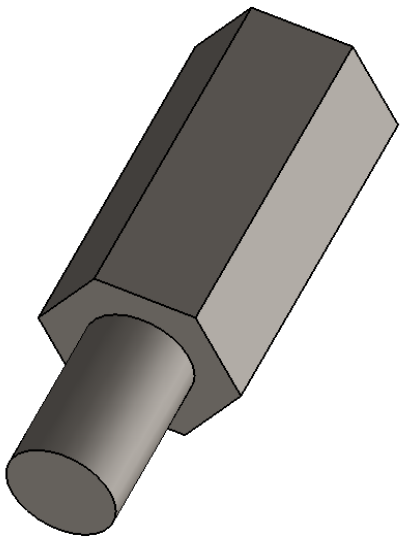

UNLESS OTHERWISE SPECIFIED:

DIMENSIONS ARE IN INCHES
 TOLERANCES:
 FRACTIONAL: +1/32
 TWO PLACE DECIMAL: ±0.015
 THREE PLACE DECIMAL: ±0.005

WEIGHT: 0.072 LB

MATERIAL: 1018 CARBON STEEL
 FINISH: N/A

DO NOT SCALE DRAWING

DRAWN: JENNA BECKER
 DATE: 06/03/2014

CHECKED: BRETT NAYUDU
 DATE: 06/03/2014

COMMENTS:

N/A

SCALE: 2:1

TITLE:

HEX BOLT

SIZE: **A**
 DWG. NO.: WS106

REV: **0**

NEXT ASSY: FA003

SHEET 1 OF 1



ADAPTIVE BASKETBALL SHOOTER

5

4

3

2

1

ITEM NO.	PART NUMBER	DESCRIPTION	QTY.
1	WS101	WINCH SHAFT	1
2	WS102	SPOOL	1
3	WS103	RATCHET GEAR	1
4	WS104	RATCHET FLANGE	1
5	WS105	RATCHET SPACER	1
6	WS106	HEX BOLT	1



ISOMETRIC SCALE 1:4

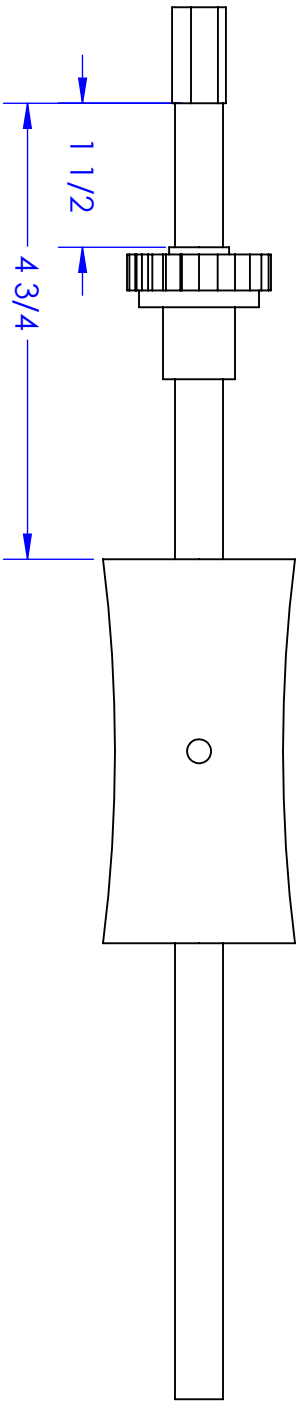

UNLESS OTHERWISE SPECIFIED:

DIMENSIONS ARE IN INCHES
 TOLERANCES:
 FRACTIONAL: +1/32
 TWO PLACE DECIMAL: ±0.015
 THREE PLACE DECIMAL: ±0.005

WEIGHT 1.19 LB

MATERIAL VARIOUS

FINISH N/A

DO NOT SCALE DRAWING

UNLESS OTHERWISE SPECIFIED:	
DRAWN	JENNA BECKER
DATE	06/03/2014
CHECKED	RICHARD GALANTI
DATE	06/03/2014

COMMENTS:

WHEN INSTALLED, THE RATCHET SPACER SHOULD MAKE CONTACT WITH THE FRAME. SET SCREWS NOT SHOWN.

TITLE:

WINCH SHAFT ASSEMBLY

SIZE	DWG. NO.	REV
A	FA003	1

NEXT ASSY: TA001 SHEET 1 OF 1

Mechanical Engineering
CAL POLY

ADAPTIVE BASKETBALL SHOOTER

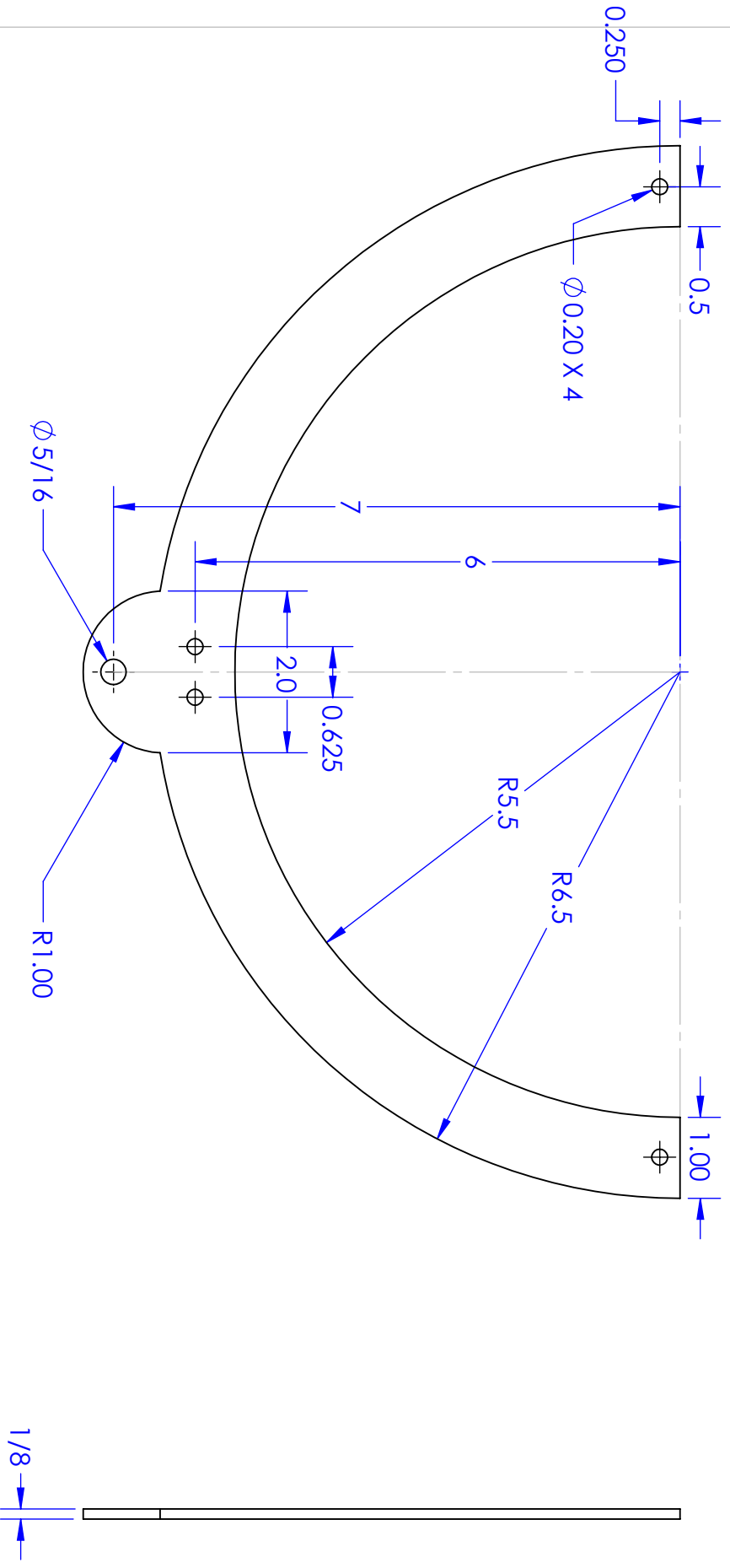

UNLESS OTHERWISE SPECIFIED:

DIMENSIONS ARE IN INCHES
 TOLERANCES:
 FRACTIONAL +1/32
 TWO PLACE DECIMAL ±0.015
 THREE PLACE DECIMAL ±0.005

WEIGHT 0.1 LB

MATERIAL 6061 ALUMINUM

FINISH N/A

DO NOT SCALE DRAWING

UNLESS OTHERWISE SPECIFIED:	
DRAWN	RICHARD GALANTI
DATE	06/06/2014
CHECKED	BRETT NAYUDU
DATE	06/06/2014

UNLESS OTHERWISE SPECIFIED:	
TITLE: PRIMARY CARRIAGE SUPPORT	
SCALE:	1:2

COMMENTS:

N/A

SIZE	DWG. NO.	REV
A	CA101	1

NEXT ASSY: FA004

SHEET 1 OF 1



ADAPTIVE BASKETBALL SHOOTER

5

4

3

2

1

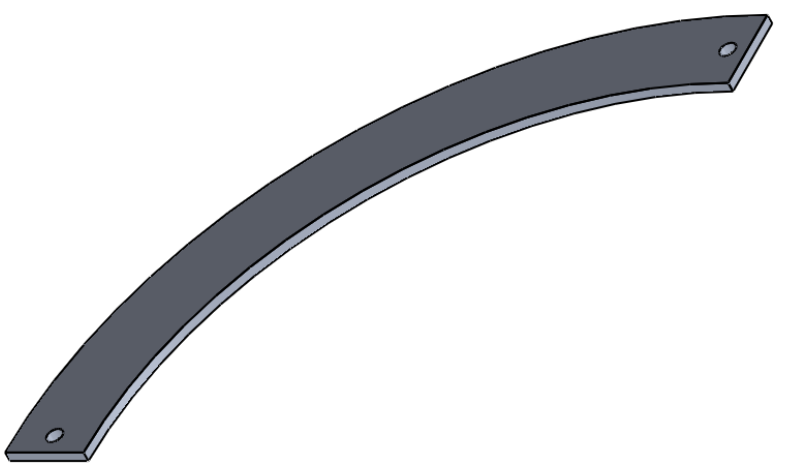
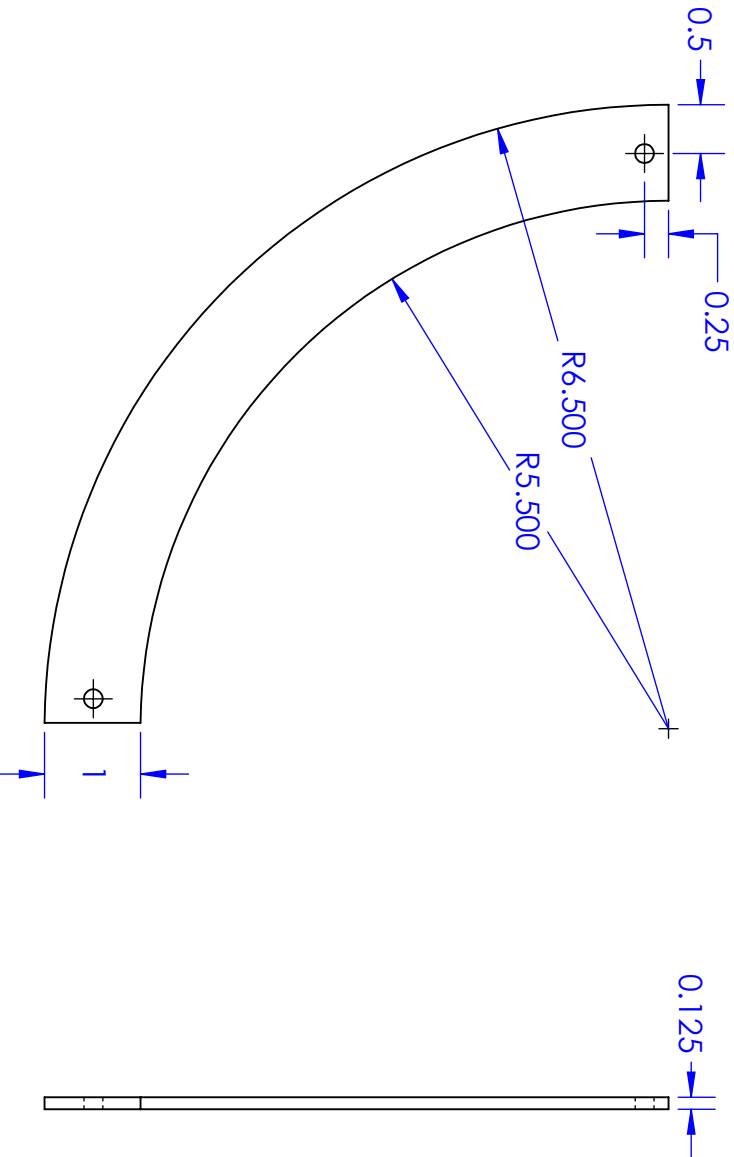

UNLESS OTHERWISE SPECIFIED:

DIMENSIONS ARE IN INCHES
 TOLERANCES:
 FRACTIONAL: +1/32
 TWO PLACE DECIMAL: ±0.015
 THREE PLACE DECIMAL: ±0.005

WEIGHT: 0.12 LB

MATERIAL: 6061 ALUMINUM

FINISH: N/A

DO NOT SCALE DRAWING

DRAWN	RICHARD GALANTI
DATE	06/04/2014
CHECKED	BRETT NAYUDU
DATE	06/04/2014

COMMENTS:

WATERJET CUT FROM 1/8 INCH THICK 6061 ALUMINUM SHEET

SCALE: 1:2

TITLE:

SECONDARY CARRIAGE SUPPORT

SIZE	DWG. NO.	REV
A	CA102	1

NEXT ASSY: FA004

SHEET 1 OF 1



ADAPTIVE BASKETBALL SHOOTER

5

4

3

2

1

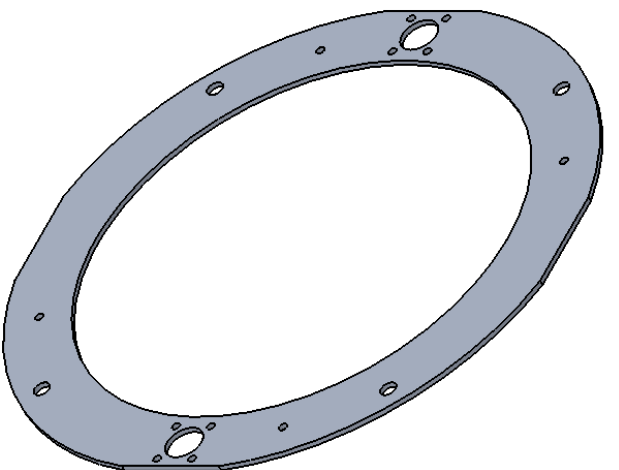
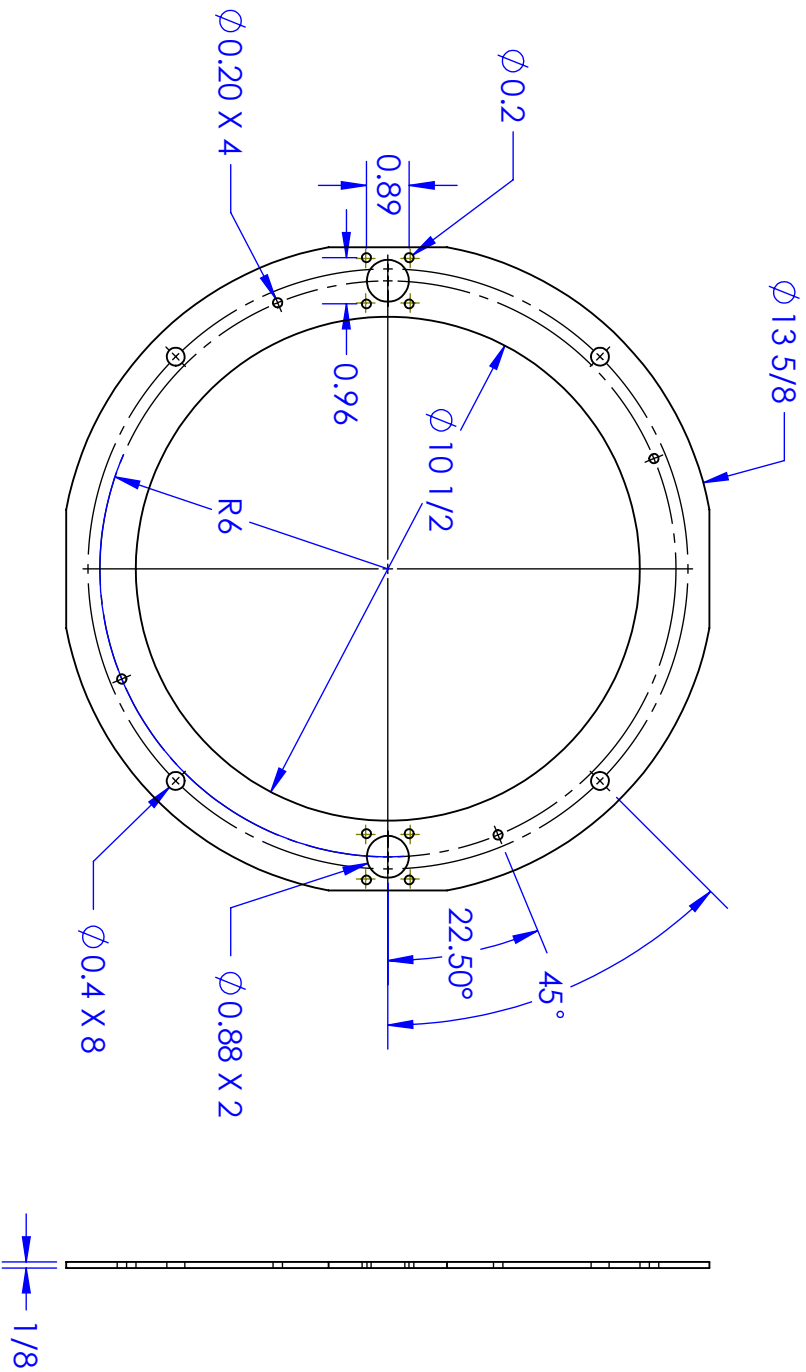

UNLESS OTHERWISE SPECIFIED:

DIMENSIONS ARE IN INCHES
TOLERANCES:
FRACTIONAL $\pm 1/32$
TWO PLACE DECIMAL ± 0.015
THREE PLACE DECIMAL ± 0.005

WEIGHT 0.68 LB

MATERIAL 6061 ALUMINUM
FINISH N/A

DO NOT SCALE DRAWING

DRAWN BRETT NAVYUDU

DATE 06/04/2014

CHECKED JENNA BECKER

DATE 06/04/2014

COMMENTS:

HOLES ON 64IN CENTER CIRCLE
EVENLY SPACED. EDGES GRIND
SO THAT THE PART CAN FIT
WITHIN A 13.5-INCH SQUARE.

TITLE:

CARRIAGE TOP PLATE

SIZE DWG. NO.

A CA103

REV

1

NEXT ASSY: FA004

SHEET 1 OF 1



ADAPTIVE BASKETBALL SHOOTER

5

4

3

2

1

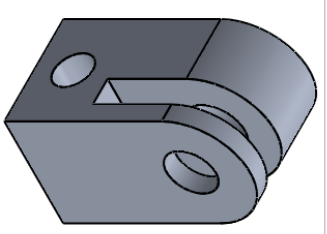
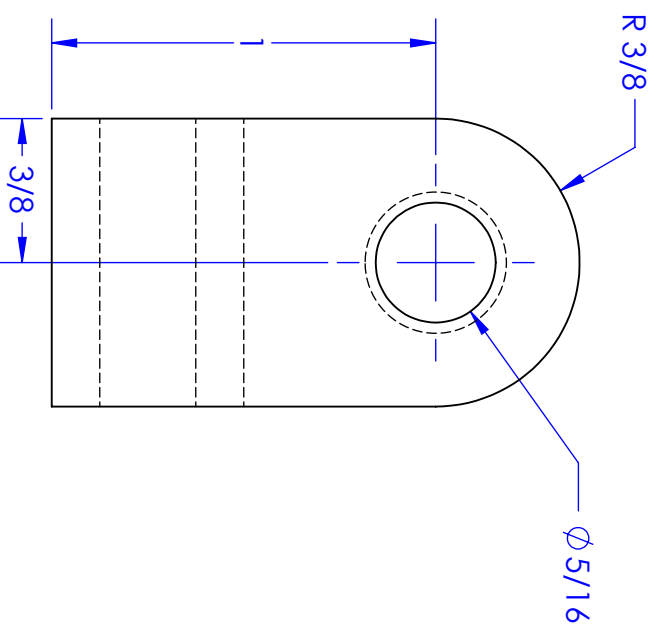
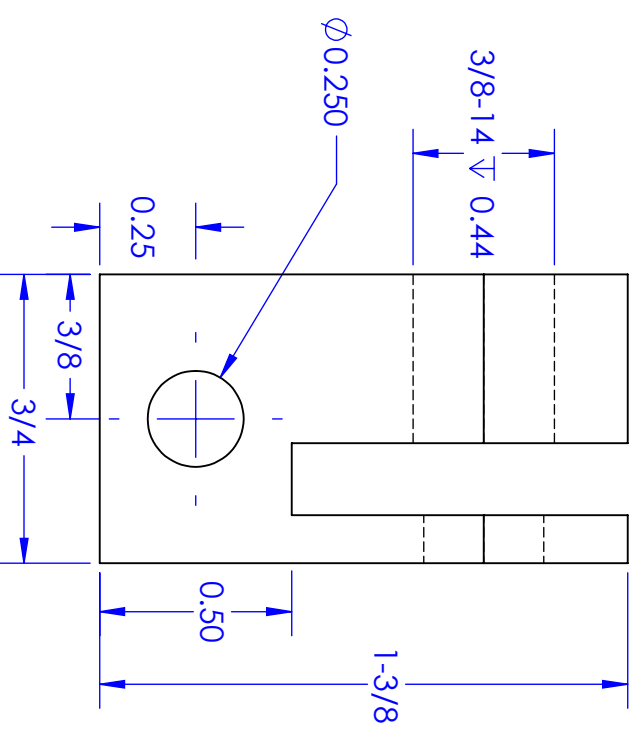
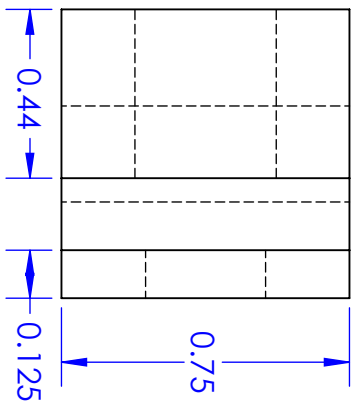

ISOMETRIC SCALE: 1:1

UNLESS OTHERWISE SPECIFIED:

DIMENSIONS ARE IN INCHES
TOLERANCES:
FRACTIONAL: +1/32
TWO PLACE DECIMAL: ±0.015
THREE PLACE DECIMAL: ±0.005

WEIGHT: 0.051 LB

MATERIAL: 6061 ALUMINUM

FINISH: N/A

DO NOT SCALE DRAWING

DRAWN	JENNA BECKER
DATE	02/06/2014
CHECKED	RICHARD GALANTI
DATE	2/6/14

COMMENTS:

PULL PIN THREADS INTO THICKER SIDE. BOTTOM HOLES ROPE ATTACHMENT POINT.

TITLE:

RELEASE BRACKET

SIZE	DWG. NO.	REV
A	CA104	1

NEXT ASSY: FA004 SHEET 1 OF 1



ADAPTIVE BASKETBALL SHOOTER

5

4

3

2

1

ITEM NO.	PART NUMBER	DESCRIPTION	QTY.
1	CA101	PRIMARY CARRIAGE SUPPORT	1
2	CA102	SECONDARY CARRIAGE SUPPORT	2
3	CA103	CARRIAGE TOP PLATE	1
4	6483K63	LINEAR SLIDE BEARING	2
5	1556A24	SMALL L BRACKET	6
6	CA105	RELEASE BRACKET	1
7	RET-375	PULL PIN	1

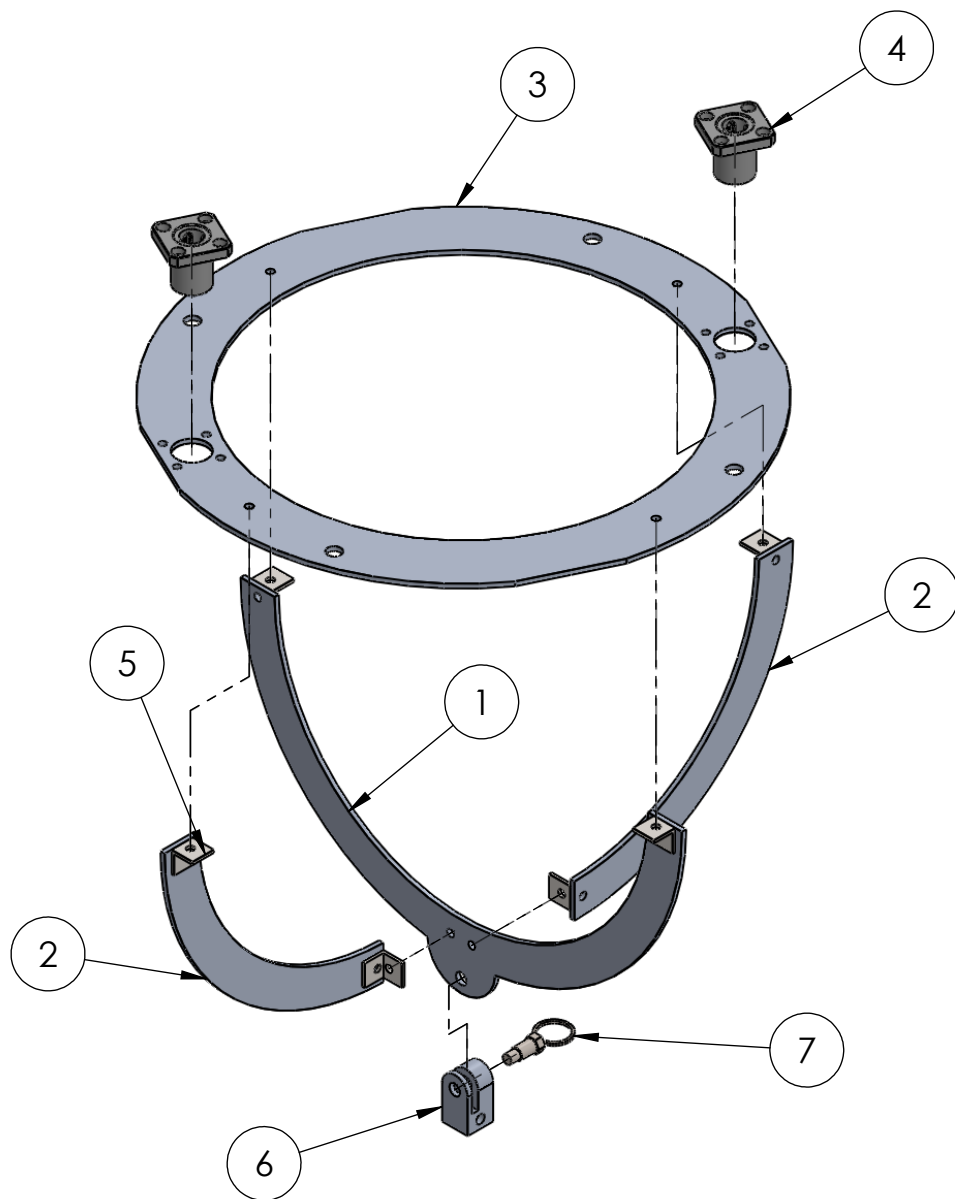

DIMENSIONS ARE IN INCHES
TOLERANCES:
FRACTIONAL: $\pm 1/32$
TWO PLACE DECIMAL: ± 0.015
THREE PLACE DECIMAL: ± 0.005

WEIGHT 1.37 LB

MATERIAL VARIOUS

FINISH N/A

DO NOT SCALE DRAWING

DRAWN JENNA BECKER

DATE 06/04/2014

CHECKED RICHARD GALANTI

DATE 06/04/2014

COMMENTS:

NUTS AND BOLTS NOT SHOWN.
TACK WELD PULL PIN'S RING
TO PREVENT UNFOLDING
DURING OPERATION.

TITLE:

CARRIAGE ASSEMBLY

SIZE DWG. NO.

A

FA004

REV.

1

SCALE: 1:4

NEXT ASSY: TA001

SHEET 1 OF 1

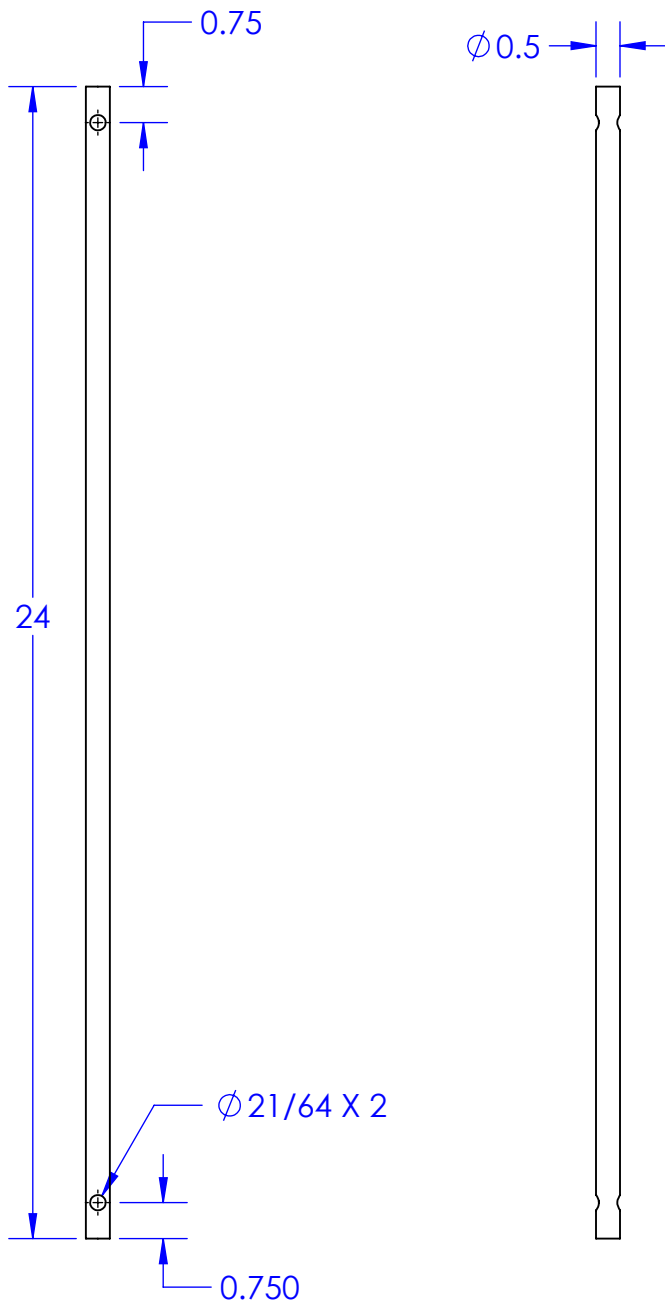

DIMENSIONS ARE IN INCHES
 TOLERANCES:
 FRACTIONAL: $\pm 1/32$
 TWO PLACE DECIMAL: ± 0.015
 THREE PLACE DECIMAL: ± 0.005

WEIGHT	1.31 LB
MATERIAL	1045 CD STEEL
FINISH	POLISHED
DO NOT SCALE DRAWING	

DRAWN	RICHARD GALANTI
DATE	02/05/2014
CHECKED	BRETT NAYUDU
DATE	02/06/2014
COMMENTS:	N/A

TITLE:		GUIDE ROD	
SIZE	DWG. NO.	REV.	
A	FA101	0	
SCALE: 1:4	NEXT ASSY: TA001	SHEET 1 OF 1	

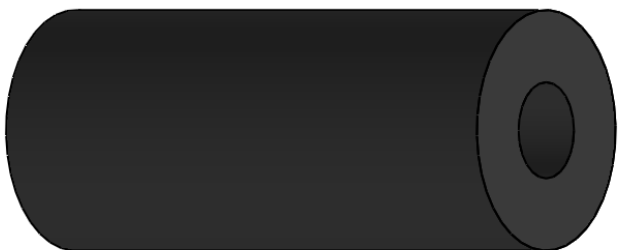
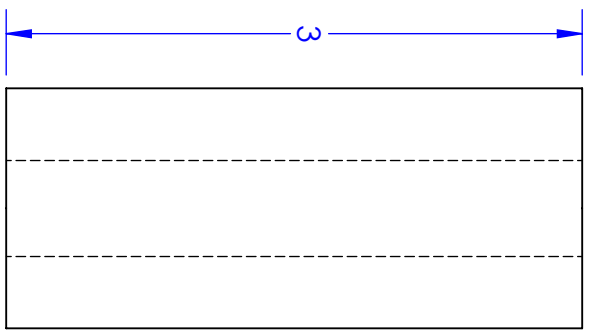
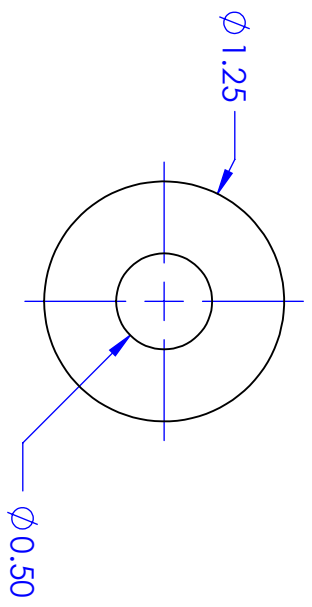

UNLESS OTHERWISE SPECIFIED:

DIMENSIONS ARE IN INCHES
 TOLERANCES:
 FRACTIONAL: +1/32
 TWO PLACE DECIMAL: ±0.015
 THREE PLACE DECIMAL: ±0.005

WEIGHT: 0.14 LB

MATERIAL: 40A POLYURETHANE
 FINISH: N/A

DO NOT SCALE DRAWING

DRAWN	JENNA BECKER
DATE	06/04/2014
CHECKED	RICHARD GALANTI
DATE	06/04/2014

COMMENTS:
 STOCK COMES WITH CORRECT
 OUTER AND INNER DIAMETER.
 MUST ONLY CUT STOCK TO
 CORRECT LENGTH.

SCALE: 1:1

TITLE:

RUBBER STOPPER

SIZE	DWG. NO.	REV
A	FA102	1

NEXT ASSY.: TA001 SHEET 1 OF 1

Mechanical Engineering
CAL POLY

ADAPTIVE BASKETBALL SHOOTER

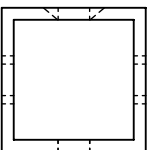
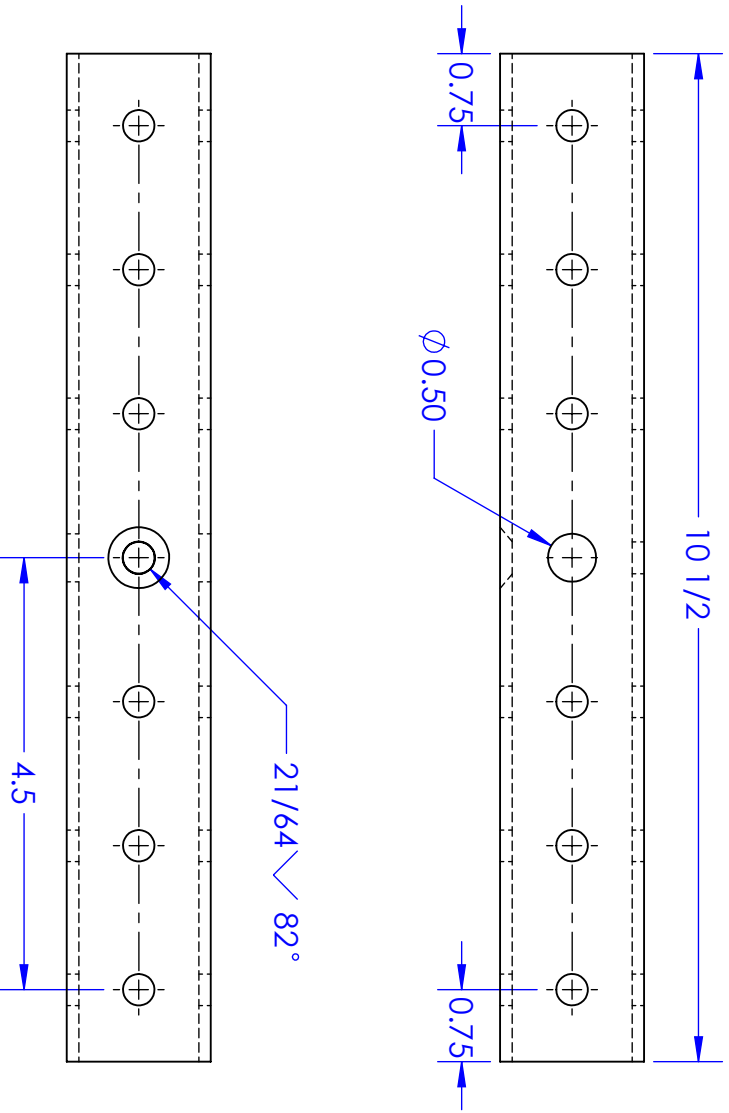
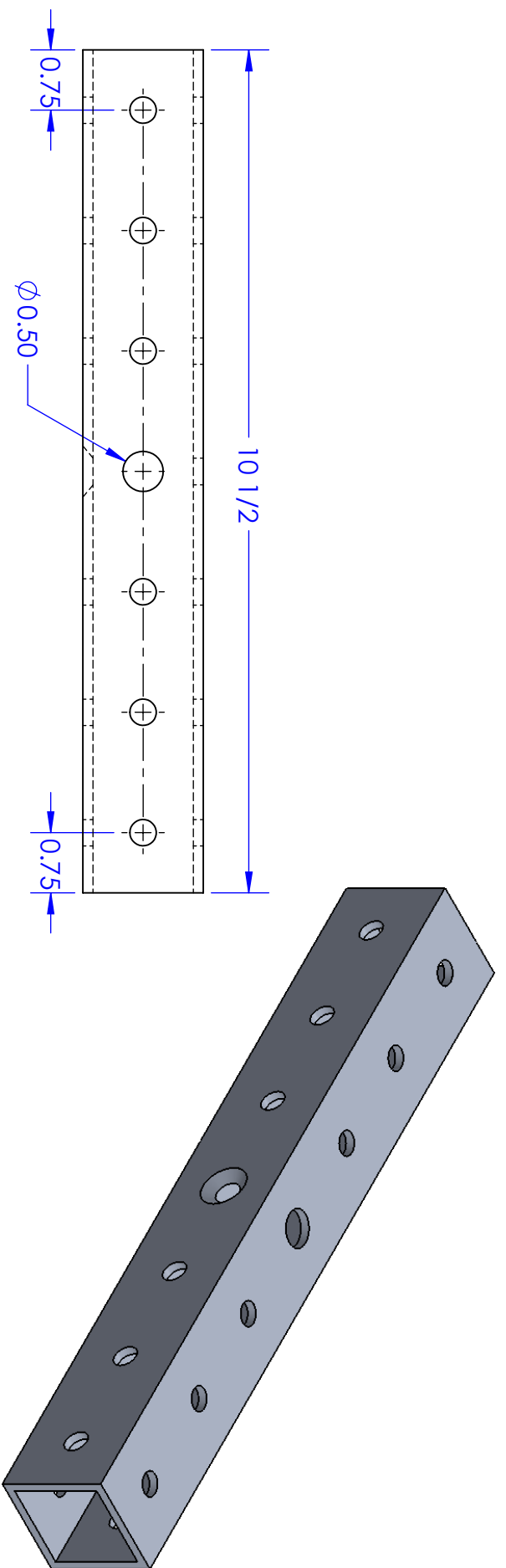

UNLESS OTHERWISE SPECIFIED:

DIMENSIONS ARE IN INCHES
 TOLERANCES:
 FRACTIONAL $\pm 1/32$
 TWO PLACE DECIMAL ± 0.015
 THREE PLACE DECIMAL ± 0.005

WEIGHT 0.673 LB

MATERIAL ALUMINUM

FINISH N/A

DO NOT SCALE DRAWING

TITLE:

TOP FRAME MEMBER 1

DRAWN	RICHARD GALANTI
DATE	06/04/2014
CHECKED	BRETT NAYUDU
DATE	06/04/2014

COMMENTS:

CUT FROM STOCK. ONLY
 MODIFICATION IS WIDENED
 GUIDE ROD HOLES.

SCALE: 1:2

SIZE DWG. NO. REV
A FA103 1

NEXT ASSY: TA001

SHEET 1 OF 1



ADAPTIVE BASKETBALL SHOOTER

5

4

3

2

1

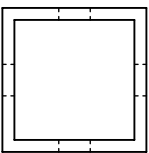
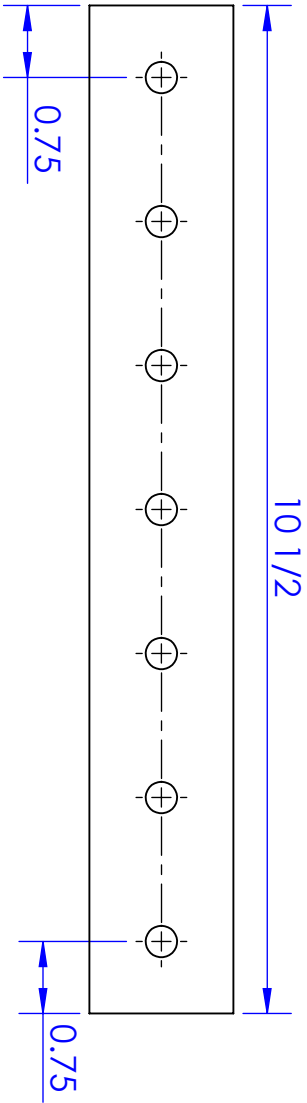
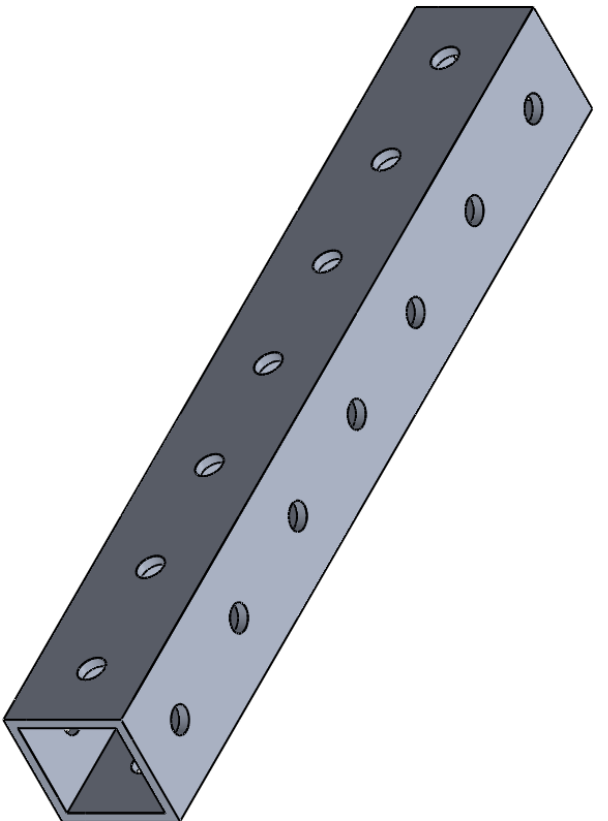

UNLESS OTHERWISE SPECIFIED:

DIMENSIONS ARE IN INCHES
 TOLERANCES:
 FRACTIONAL +1/32
 TWO PLACE DECIMAL ±0.015
 THREE PLACE DECIMAL ±0.005

WEIGHT 0.675 LB

MATERIAL ALUMINUM

FINISH N/A

DO NOT SCALE DRAWING

DRAWN RICHARD GALANTI

DATE 02/06/2014

CHECKED BRETT NAYUDU

DATE 02/06/2014

COMMENTS:

CUT FROM STOCK. NO OTHER MODIFICATIONS.

SCALE: 1:2

TITLE:

TOP FRAME MEMBER 2

SIZE DWG. NO.

A FA104

REV

0

NEXT ASSY: XXXX

SHEET 1 OF 1



ADAPTIVE BASKETBALL SHOOTER

5

4

3

2

1

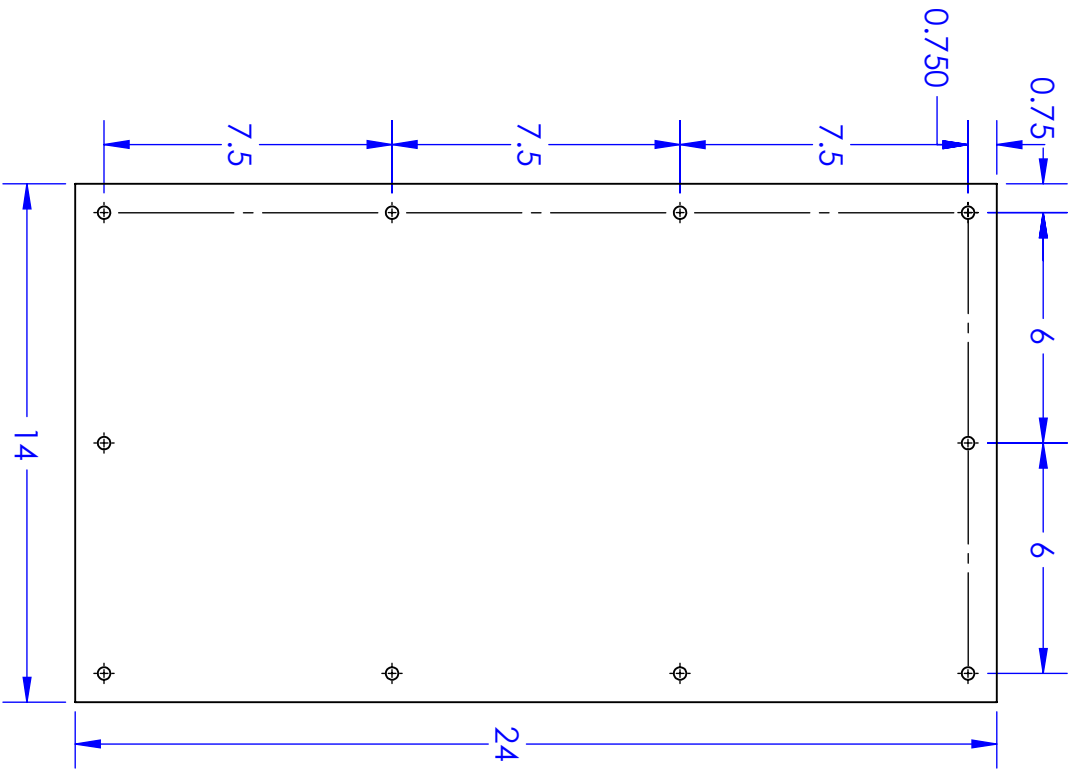

UNLESS OTHERWISE SPECIFIED:

DIMENSIONS ARE IN INCHES
 TOLERANCES:
 FRACTIONAL: +1/32
 TWO PLACE DECIMAL: ±0.015
 THREE PLACE DECIMAL: ±0.005

WEIGHT 1.3 LB

MATERIAL POLYCARBONATE

FINISH N/A

DO NOT SCALE DRAWING

DRAWN	RICHARD GALANTI
DATE	06/04/2014
CHECKED	BRETT NAYUDU
DATE	06/04/2014
COMMENTS:	

SCALE: 1:5

TITLE:
FRONT SAFETY CASING

SIZE	DWG. NO.	REV
A	FA105	1

NEXT ASSY: TA001 SHEET 1 OF 1

Mechanical Engineering
CAL POLY

ADAPTIVE BASKETBALL SHOOTER

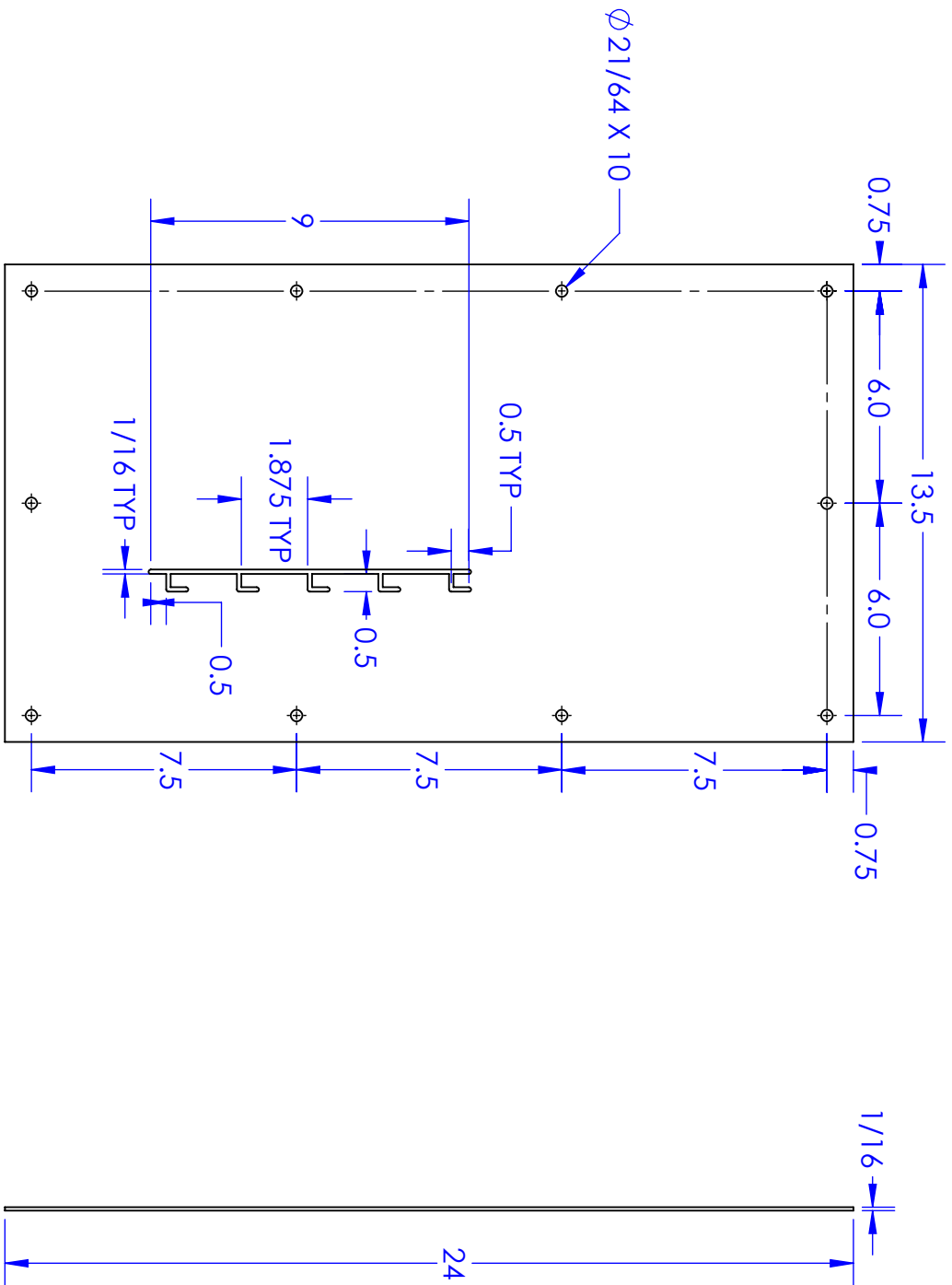

UNLESS OTHERWISE SPECIFIED:

DIMENSIONS ARE IN INCHES
 TOLERANCES:
 FRACTIONAL: +1/32
 TWO PLACE DECIMAL: ±0.015
 THREE PLACE DECIMAL: ±0.005

WEIGHT 1.29 LB

MATERIAL POLYCARBONATE
 FINISH N/A

DO NOT SCALE DRAWING

DRAWN	RICHARD GALANTI
DATE	06/05/2014
CHECKED	BRETT NAYUDU
DATE	06/05/2014

TITLE:
BACK SAFETY CASING

COMMENTS:
 ALONG SLOT, ALL PRONGS ARE
 EQUIDISTANT FROM EACH OTHER
 AND EQUAL IN SIZE

SCALE: 1:5

SCALE: 1:5

Mechanical Engineering
CAL POLY

ADAPTIVE BASKETBALL SHOOTER

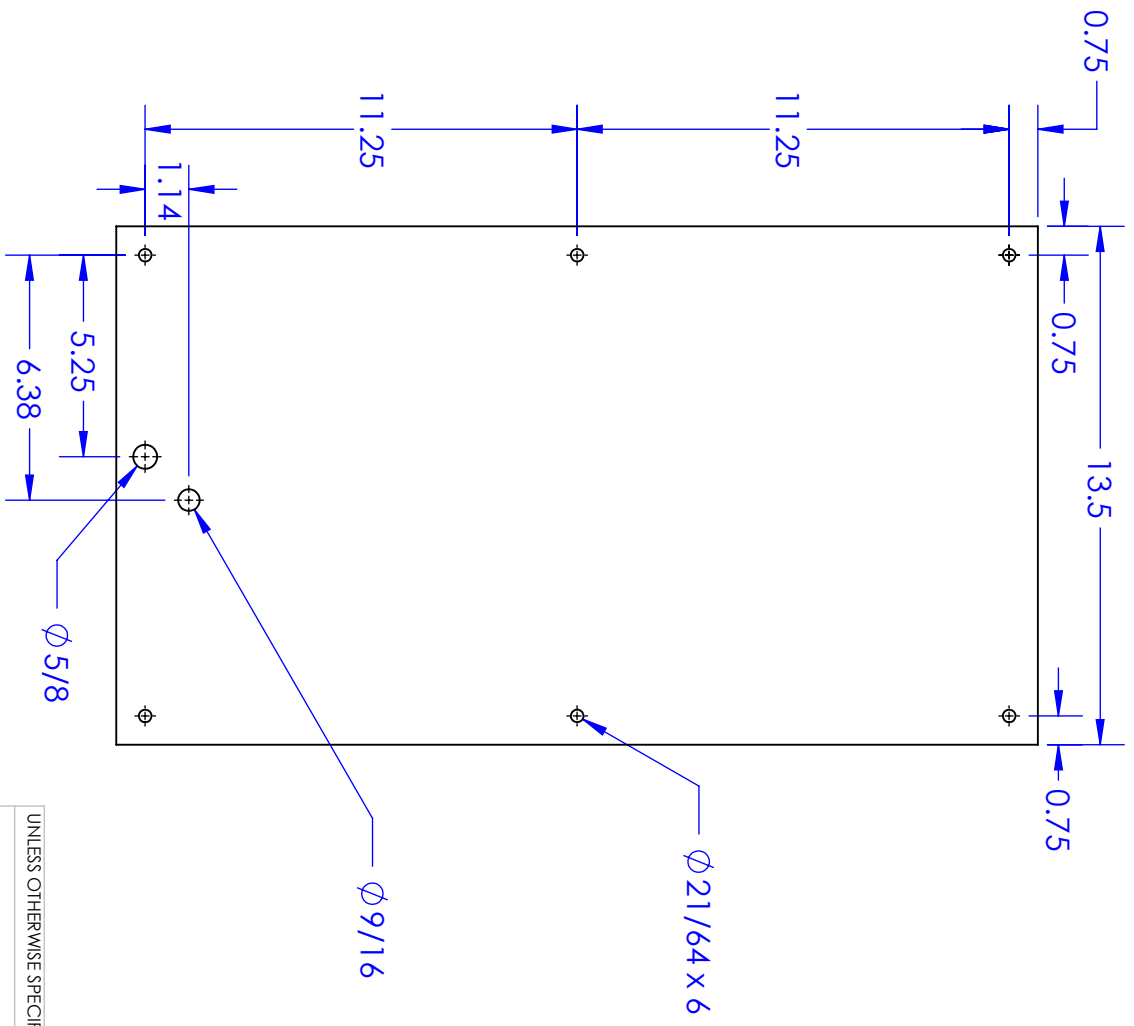

UNLESS OTHERWISE SPECIFIED:

DIMENSIONS ARE IN INCHES
 TOLERANCES:
 FRACTIONAL +1/32
 TWO PLACE DECIMAL ±0.015
 THREE PLACE DECIMAL ±0.005

WEIGHT 1.28 LB

MATERIAL POLYCARBONATE

FINISH N/A

DO NOT SCALE DRAWING

DRAWN	RICHARD GALANTI
DATE	06/04/2014
CHECKED	JENNA BECKER
DATE	06.04/2014
COMMENTS:	

SCALE: 1:5

N/A

TITLE:
LEFT SAFETY CASING

SIZE	DWG. NO.	REV
A	FA107	1

NEXT ASSY.: TA001 SHEET 1 OF 1

Mechanical Engineering
CAL POLY

ADAPTIVE BASKETBALL SHOOTER

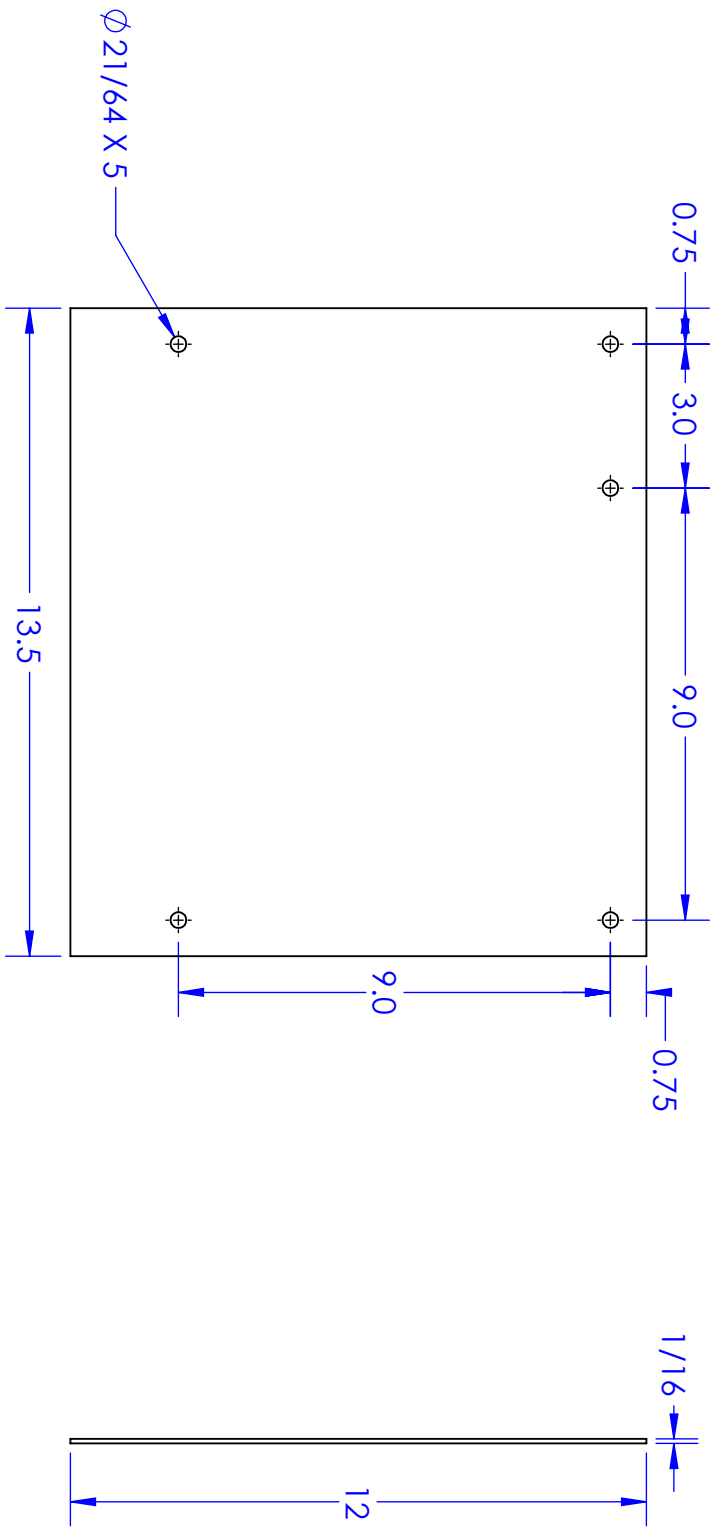

UNLESS OTHERWISE SPECIFIED:

DIMENSIONS ARE IN INCHES
 TOLERANCES:
 FRACTIONAL +1/32
 TWO PLACE DECIMAL ±0.015
 THREE PLACE DECIMAL ±0.005

WEIGHT 0.65 LB

MATERIAL POLYCARBONATE

FINISH N/A

DO NOT SCALE DRAWING

DRAWN RICHARD GALANTI

DATE 06/05/2014

CHECKED BRETT NAYUDU

DATE 06/05/2014

COMMENTS:

N/A

SCALE: 1:4

TITLE:

RIGHT UPPER SAFETY CASING

SIZE DWG. NO.

A FA108

REV

1

NEXT ASSY: TA001

SHEET 1 OF 1



ADAPTIVE BASKETBALL SHOOTER

5

4

3

2

1

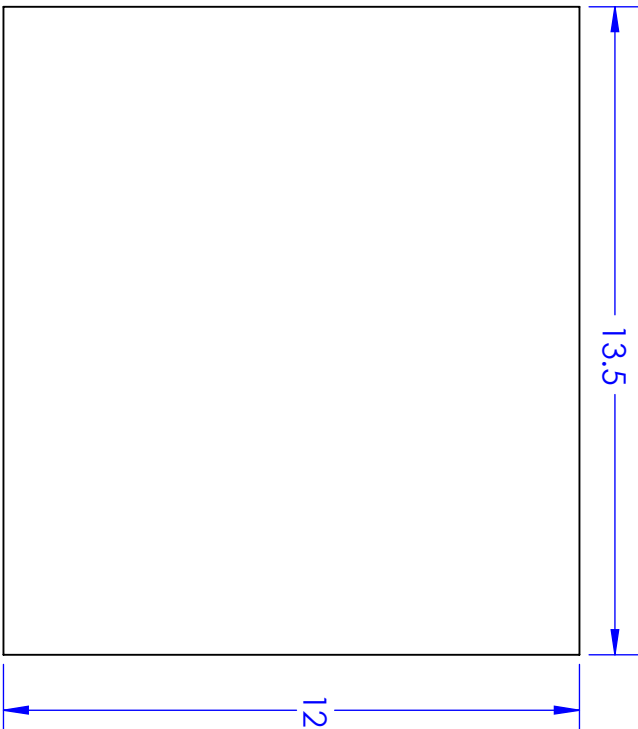

1/16

UNLESS OTHERWISE SPECIFIED:

DIMENSIONS ARE IN INCHES
 TOLERANCES:
 FRACTIONAL +1/32
 TWO PLACE DECIMAL ±0.015
 THREE PLACE DECIMAL ±0.005

WEIGHT 0.65 LB

MATERIAL POLYCARBONATE

FINISH N/A

DO NOT SCALE DRAWING

DRAWN RICHARD GALANTI

DATE 06/05/2014

CHECKED BRETT NAYUDU

DATE 06/05/2014

COMMENTS:

N/A

SCALE: 1:4

TITLE:

RIGHT LOWER SAFETY CASING

SIZE DWG. NO.

A FA109

REV

1

NEXT ASSY: TA001

SHEET 1 OF 1



ADAPTIVE BASKETBALL SHOOTER

5

4

3

2

1

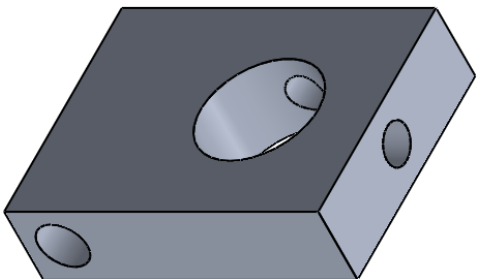
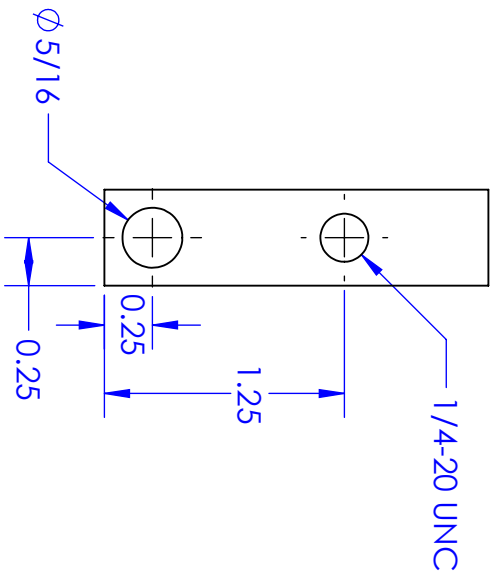
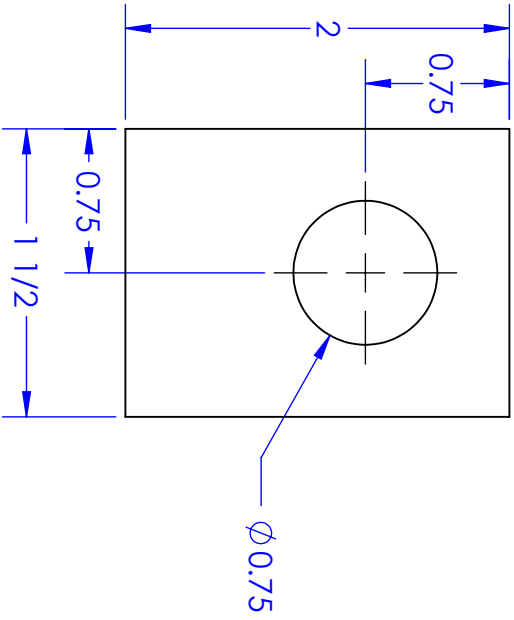
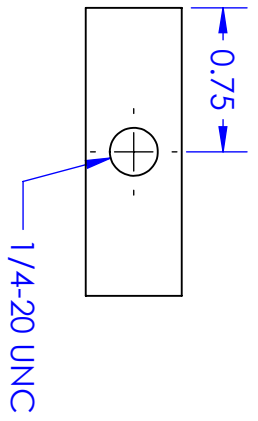

UNLESS OTHERWISE SPECIFIED:

DIMENSIONS ARE IN INCHES
 TOLERANCES:
 FRACTIONAL: +1/32
 TWO PLACE DECIMAL: ±0.015
 THREE PLACE DECIMAL: ±0.005

WEIGHT: 0.11 LB

MATERIAL: ALUMINUM

FINISH: N/A

DO NOT SCALE DRAWING

DRAWN	RICHARD GALANTI
DATE	06/09/2014
CHECKED	BRETT NAYUDU
DATE	06/09/2014

COMMENTS:

N/A

SCALE: 1:1

TITLE:

LEAD SCREW HINGE

SIZE	DWG. NO.	REV
A	FA110	1
NEXT ASSY.: TA001		SHEET 1 OF 1

Mechanical Engineering
 SolidWorks Student Edition.
 For Academic Use Only.

ADAPTIVE BASKETBALL SHOOTER

ITEM NO.	PART NUMBER	DESCRIPTION	QTY.
1	FA001	LOWER FRAME ASSEMBLY	1
2	FA002	PAWL BLOCK ASSEMBLY	1
3	FA003	WINCH SHAFT ASSEMBLY	1
4	FA101	GUIDE ROD	2
5	FA004	CARRIAGE ASSEMBLY	1
6	FA102	RUBBER STOPPER	2
7	FA103	TOP FRAME MEMBER 1	2
8	FA104	TOP FRAME MEMBER 2	2
9	3014T257	5/16-24 EYE BOLT	4
10	8809T41	TUBE CAP	4
11	FA105	FRONT SAFETY CASING	1
12	FA106	BACK SAFETY CASING	1
13	FA107	LEFT SAFETY CASING	1
14	FA108	RIGHT UPPER SAFETY CASING	1
15	FA109	RIGHT LOWER SAFETY CASING	1
16	FA110	LEAD SCREW HINGE	2
17	95100A101	ACME CYLINDER NUT	2

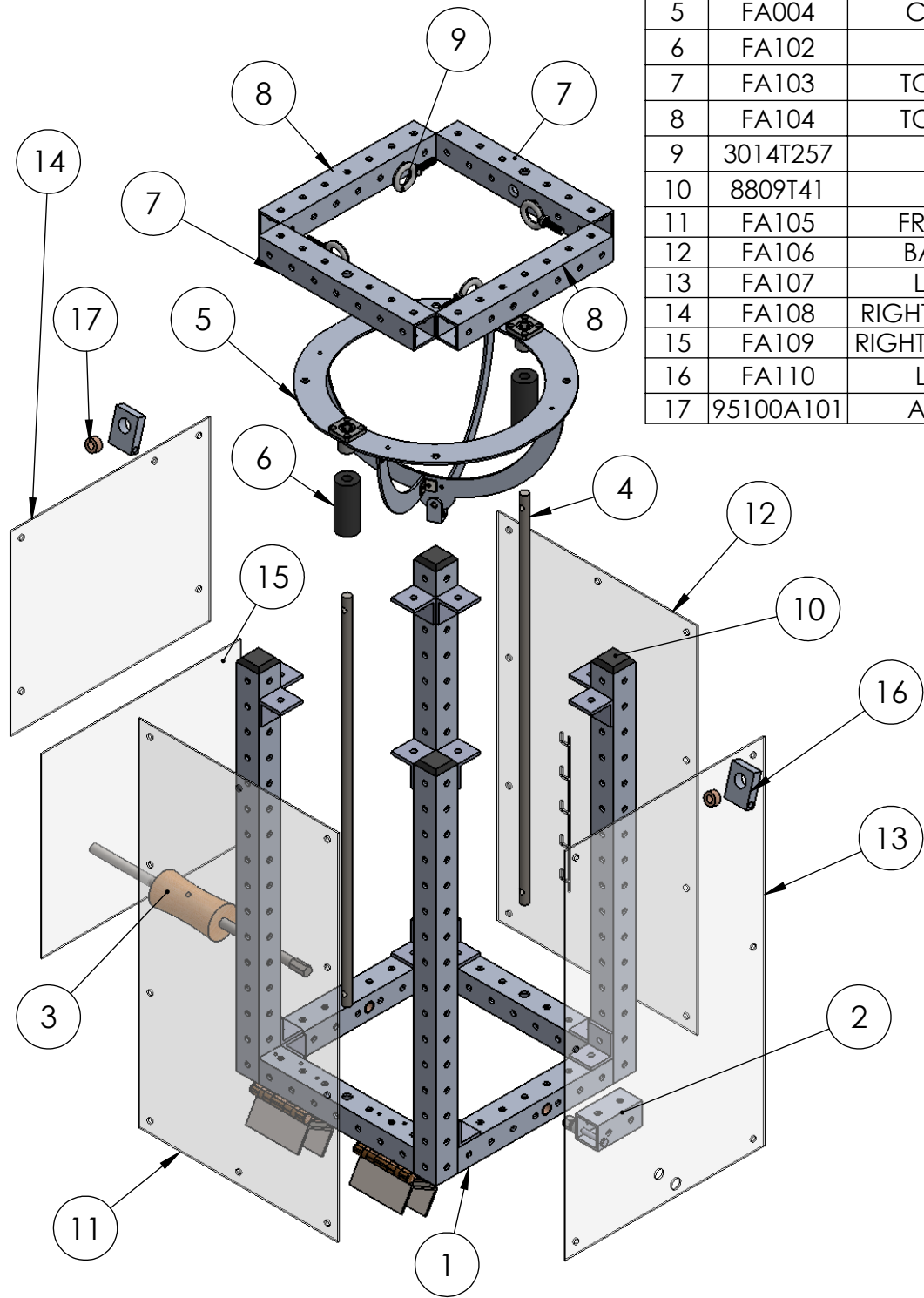

DIMENSIONS ARE IN INCHES	
TOLERANCES:	
FRACTIONAL: ±1/32	
TWO PLACE DECIMAL: ±0.015	
THREE PLACE DECIMAL: ±0.005	
WEIGHT	26.2 LB
MATERIAL	VARIOUS
FINISH	N/A
DO NOT SCALE DRAWING	

DRAWN	JENNA BECKER
DATE	06/05/2014
CHECKED	RICHARD GALANTI
DATE	06/05/2014
COMMENTS:	
PINS, BOLTS, AND NUTS NOT SHOWN	

TITLE:		FRAME ASSEMBLY	
SIZE	DWG. NO.	REV.	
A	TA001	0	
SCALE: 1:8	NEXT ASSY: TA004	SHEET 1 OF 1	



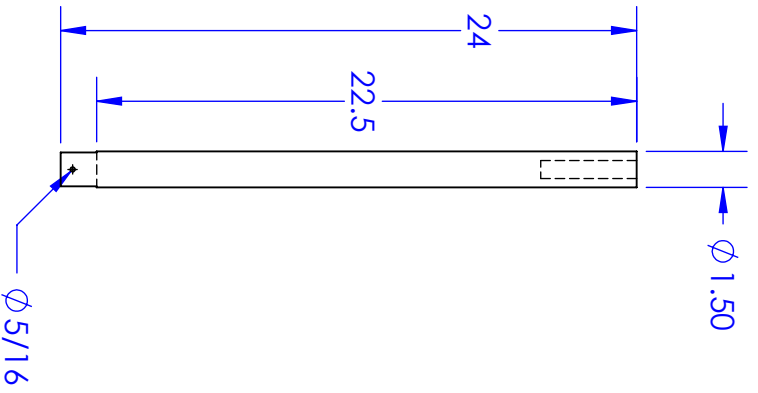

⊕ $\phi 3/4 \nabla 4$

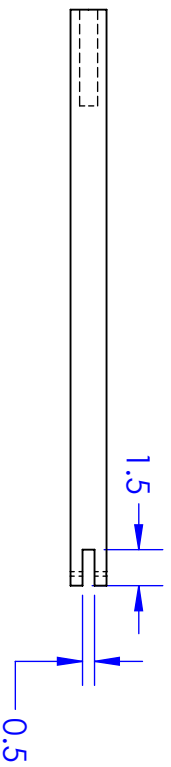

UNLESS OTHERWISE SPECIFIED:

DIMENSIONS ARE IN INCHES
TOLERANCES:
FRACTIONAL: +1/32
TWO PLACE DECIMAL: ±0.015
THREE PLACE DECIMAL: ±0.005

WEIGHT: 1.09 LB

MATERIAL: OAK

FINISH: NONE

DO NOT SCALE DRAWING

DRAWN	RICHARD GALANTI
DATE	06/05/2014
CHECKED	BRETT NAYUDU
DATE	06/05/2014

COMMENTS:

N/A

SCALE: 1:8

TITLE:

LOWER RATCHET ARM

SIZE	DWG. NO.	REV
A	RA001	1

NEXT ASSY: TA002

SHEET 1 OF 1



ADAPTIVE BASKETBALL SHOOTER

5

4

3

2

1

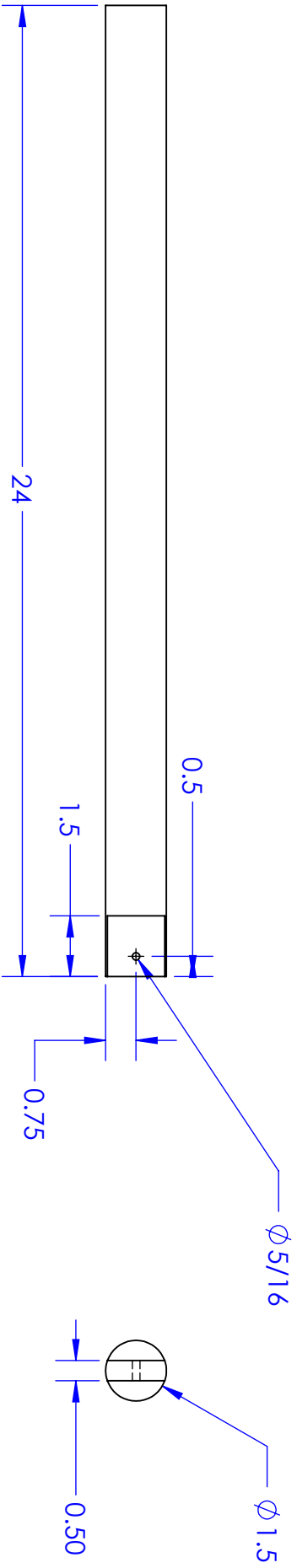

UNLESS OTHERWISE SPECIFIED:

DIMENSIONS ARE IN INCHES
 TOLERANCES:
 FRACTIONAL: +1/32
 TWO PLACE DECIMAL: ±0.015
 THREE PLACE DECIMAL: ±0.005

WEIGHT 1.26 LB

MATERIAL OAK

FINISH NONE

DO NOT SCALE DRAWING

DRAWN	BRETT NAVUDU
DATE	06/05/2014
CHECKED	JENNA BECKER
DATE	06/05/2014
COMMENTS:	

N/A

SCALE: 1:8

TITLE:

UPPER RATCHET ARM

SIZE	DWG. NO.	REV
A	RA002	1

NEXT ASSY: 1A002 SHEET 1 OF 1

Mechanical Engineering
 SolidWorks Student Edition.
 For Academic Use Only.

ADAPTIVE BASKETBALL SHOOTER

5

4

3

2

1

ITEM NO.	PART NUMBER	DESCRIPTION	QTY.
1	RA001	LOWER CRANK ARM	1
2	RA002	UPPER CRANK ARM	1
3	HMDPT001	RATCHET WRENCH	1
4	5388K26	HOSE CLAMP	2
5	97245A661	1.5-INCH CLEVIS PIN	1

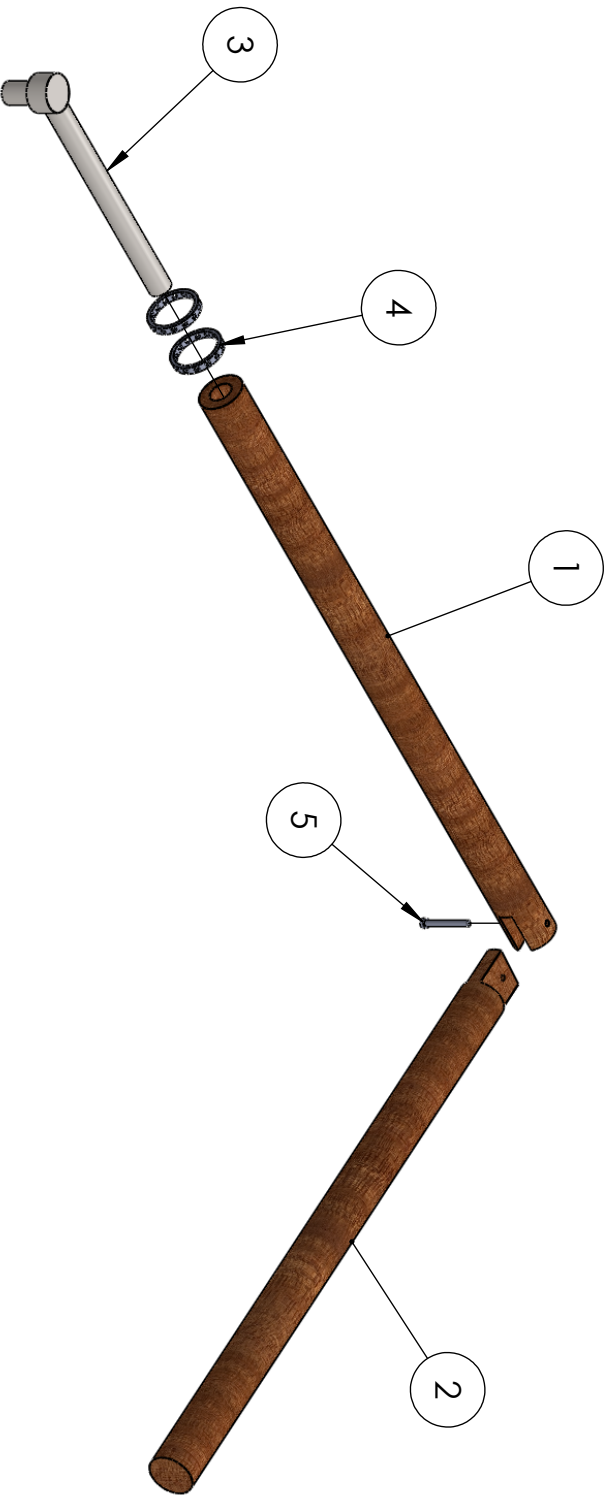

UNLESS OTHERWISE SPECIFIED:

DIMENSIONS ARE IN INCHES
 TOLERANCES:
 FRACTIONAL: +1/32
 TWO PLACE DECIMAL: ±0.015
 THREE PLACE DECIMAL: ±0.005

WEIGHT 3.12 LB

MATERIAL VARIOUS

FINISH N/A

DO NOT SCALE DRAWING

UNLESS OTHERWISE SPECIFIED:	
DRAWN	JENNA BECKER
DATE	06/05/2014
CHECKED	RICHARD GALANTI
DATE	06/05/2014

TITLE:
RATCHET ARM ASSEMBLY

SIZE DWG. NO. **A** TA002

REV **1**

NEXT ASSY: TA004 SHEET 1 OF 1

ADAPTIVE BASKETBALL SHOOTER



5

4

3

2

1

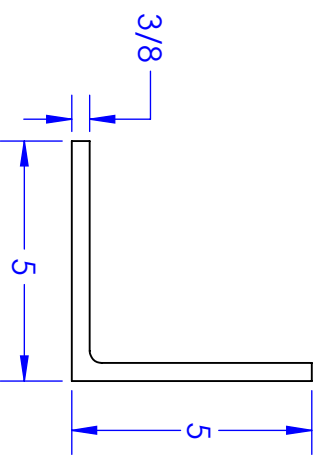
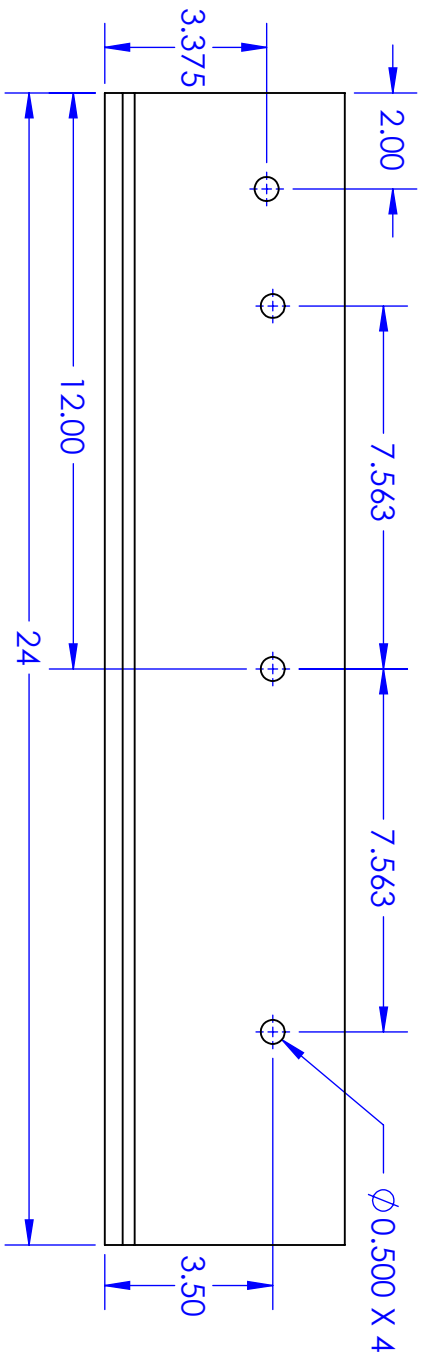
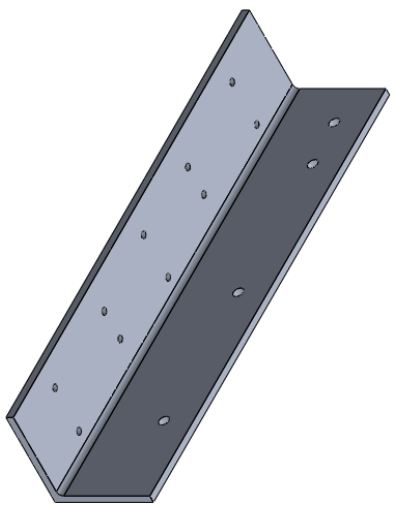
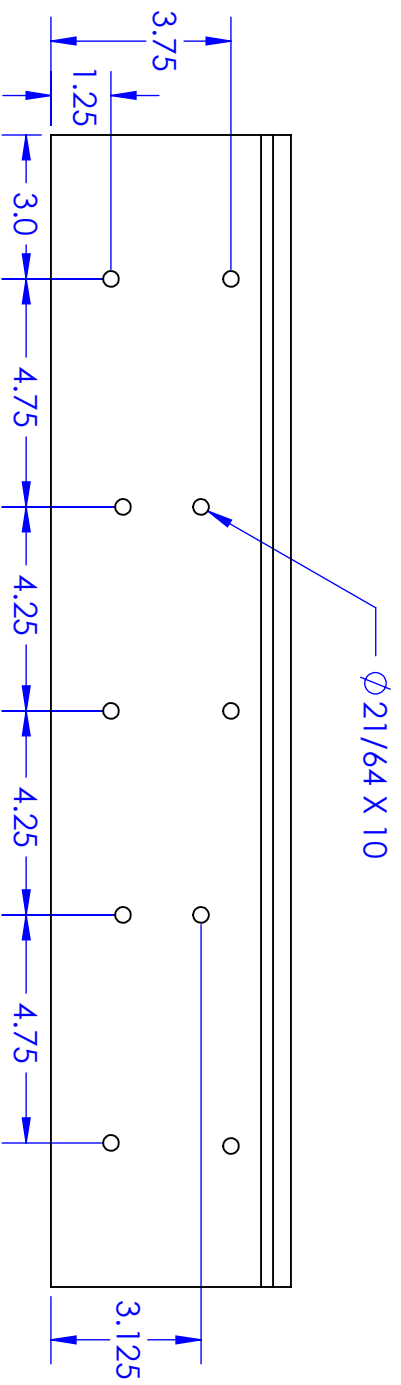

UNLESS OTHERWISE SPECIFIED:

DIMENSIONS ARE IN INCHES
TOLERANCES:
FRACTIONAL: +1/32
TWO PLACE DECIMAL: ±0.015
THREE PLACE DECIMAL: ±0.005

WEIGHT 8.42 LB

MATERIAL 6061 ALUMINUM

FINISH N/A

DO NOT SCALE DRAWING

DRAWN	JENNA BECKER
DATE	06/06/2014
CHECKED	RICHARD GALANTI
DATE	06/06/2014

TITLE:

TABLE TOP BASE

COMMENTS:

STOCK IS ALUMINUM ANGLE. SO ONLY HOLES MUST BE MACHINED. LARGE HOLES DESIGNED FOR PRESS FITS.

SIZE DWG. NO.

A TT101

REV

1

NEXT ASSY: AA001

SHEET 1 OF 1



ADAPTIVE BASKETBALL SHOOTER

5

4

3

2

1

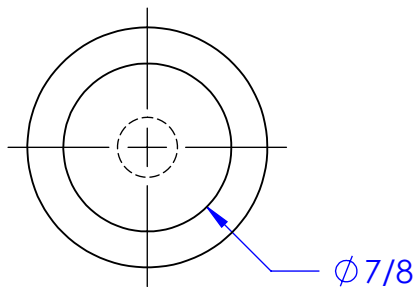
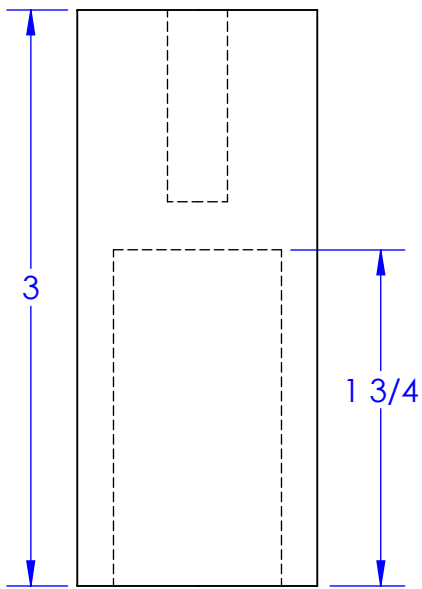
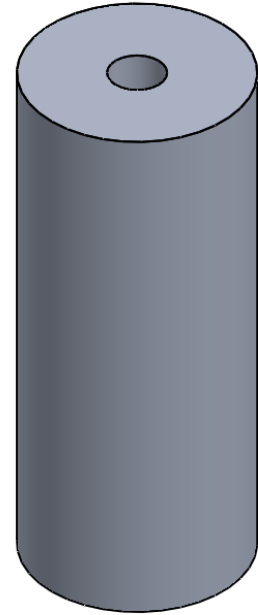
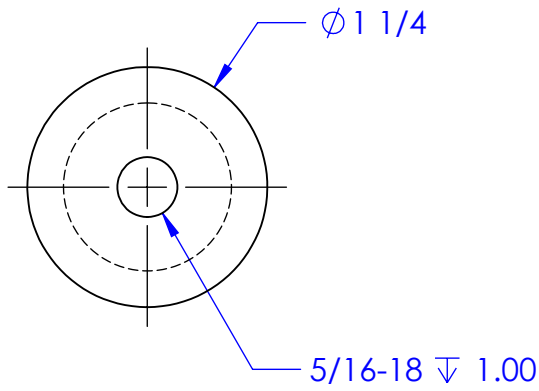

DIMENSIONS ARE IN INCHES
 TOLERANCES:
 FRACTIONAL: $\pm 1/32$
 TWO PLACE DECIMAL: ± 0.015
 THREE PLACE DECIMAL: ± 0.005

WEIGHT 0.25 LB

MATERIAL 6061 ALUMINUM

FINISH N/A

DO NOT SCALE DRAWING

DRAWN JENNA BECKER

DATE 06/06/2014

CHECKED RICHARD GALANTI

DATE 06/06/2014

COMMENTS:

IT IS IMPORTANT THAT THE TOP SURFACE OF EACH PEG IS FLAT FOR BEST ASSEMBLY.

TITLE:

TABLE TOP PEG

SIZE DWG. NO. **A** XXXXXX

REV. **1**

SCALE: 1:1 NEXT ASSY: XXXXXX

SHEET 1 OF 1



ADAPTIVE BASKETBALL SHOOTER

ITEM NO.	PART NUMBER	DESCRIPTION	QTY.
1	TT101	TABLE TOP BASE	1
2	TT102	TABLE TOP PEG	6

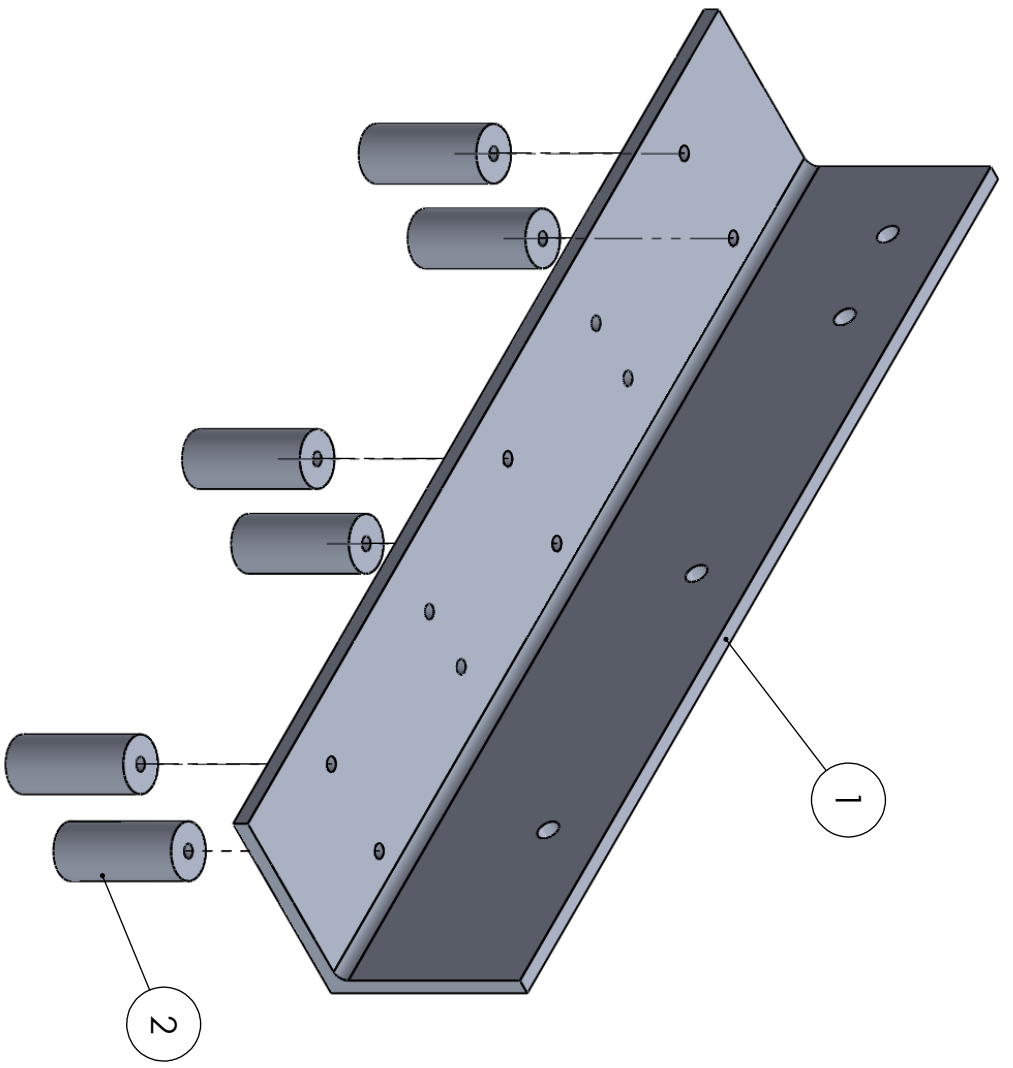

UNLESS OTHERWISE SPECIFIED:

DIMENSIONS ARE IN INCHES
 TOLERANCES:
 FRACTIONAL +1/32
 TWO PLACE DECIMAL ±0.015
 THREE PLACE DECIMAL ±0.005

WEIGHT 9.92 LB

MATERIAL 6061 ALUMINIUM

FINISH N/A

DO NOT SCALE DRAWING

DRAWN	JENNA BECKER
DATE	06/06/2014
CHECKED	RICHARD GALANTI
DATE	06/06/2014

COMMENTS:

BOLTS NOT SHOWN

SCALE: 1:4

TITLE:

TABLE TOP ASSEMBLY

SIZE	DWG. NO.	REV
A	AA001	0
NEXT ASSY:	TA003	SHEET 1 OF 1



CAL POLY

ADAPTIVE BASKETBALL SHOOTER

5

4

3

2

1

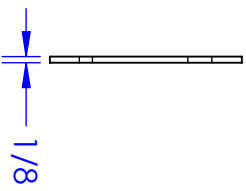
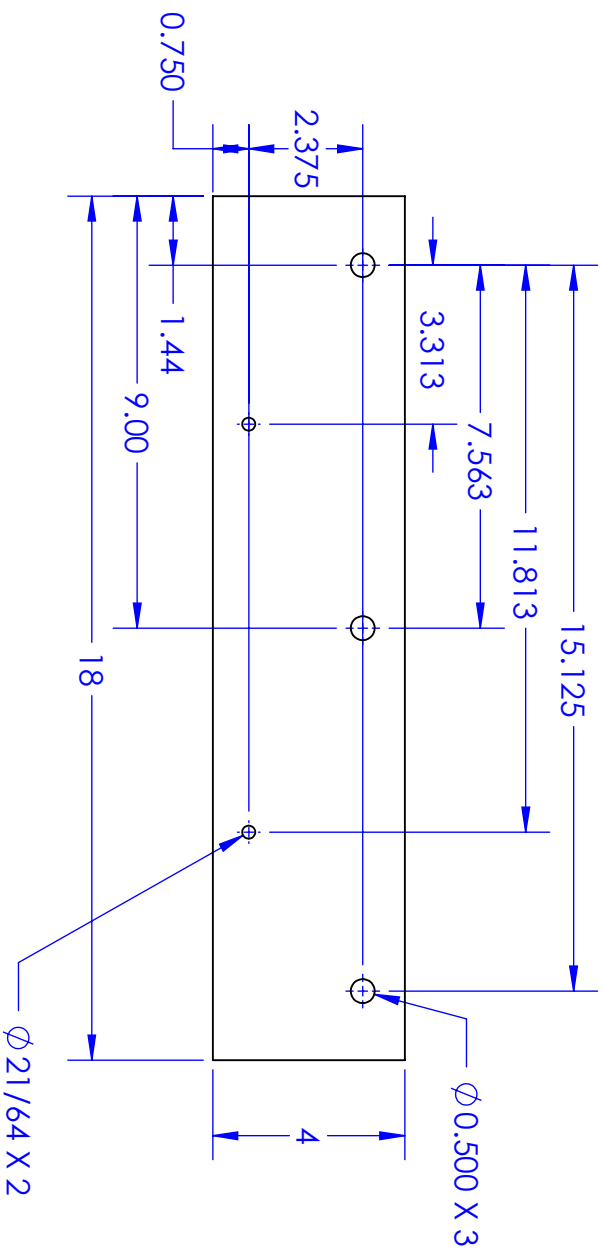
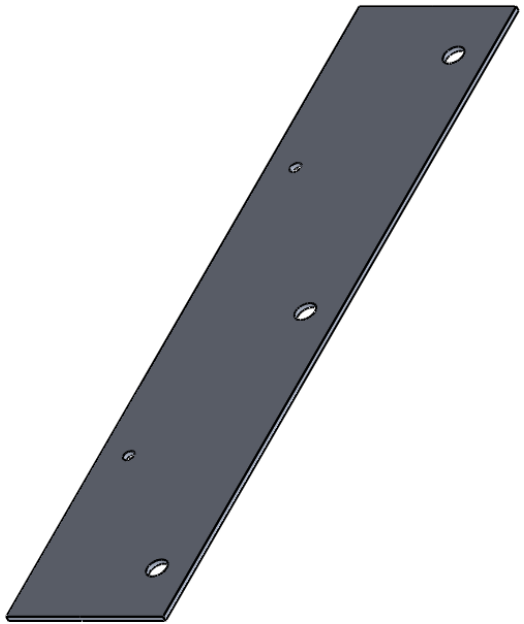

UNLESS OTHERWISE SPECIFIED:

DIMENSIONS ARE IN INCHES
TOLERANCES:
FRACTIONAL $\pm 1/32$
TWO PLACE DECIMAL ± 0.015
THREE PLACE DECIMAL ± 0.005

WEIGHT 0.87 LB

MATERIAL 6061 ALUMINIUM
FINISH N/A

DO NOT SCALE DRAWING

DRAWN	JENNA BECKER
DATE	06/06/2014
CHECKED	RICHARD GALANTI
DATE	06/06/2014

COMMENTS:
THE 1/2-INCH HOLES ARE TO HAVE BRONZE SLEEVE BEARINGS PRESSED INTO THEM

SCALE: 1:4

TITLE:

SUPPORT PLATE

SIZE	DWG. NO.	REV
A	AA103	1

NEXT ASSY: TA003

SHEET 1 OF 1



ADAPTIVE BASKETBALL SHOOTER

5

4

3

2

1

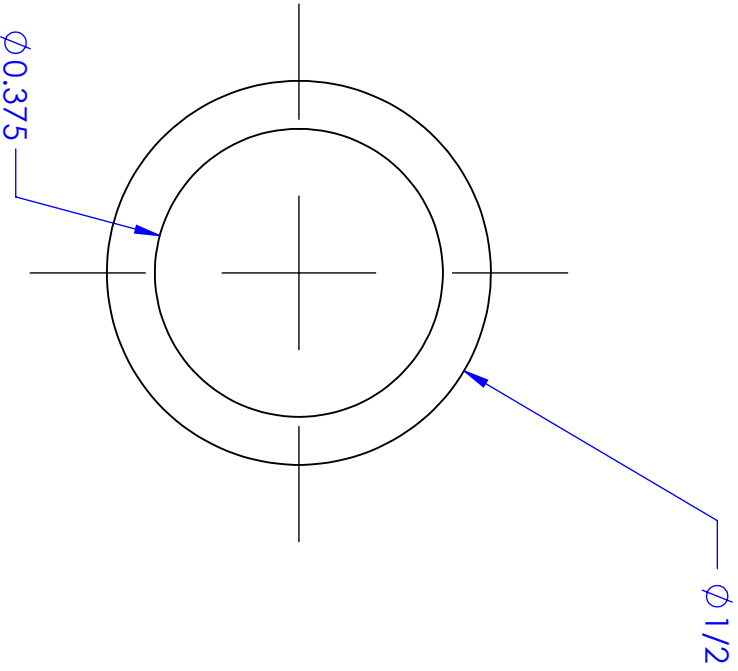
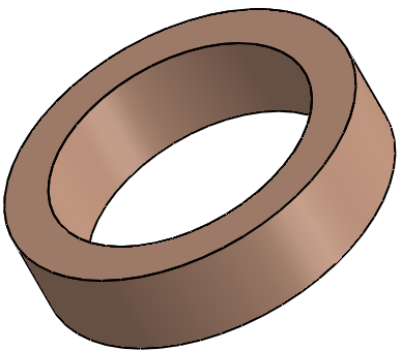

UNLESS OTHERWISE SPECIFIED:

DIMENSIONS ARE IN INCHES
 TOLERANCES:
 FRACTIONAL: +1/32
 TWO PLACE DECIMAL: ±0.015
 THREE PLACE DECIMAL: ±0.005

WEIGHT: NEGLIGIBLE

MATERIAL: BRONZE

FINISH: N/A

DO NOT SCALE DRAWING

DRAWN	BRETT NAVUDU
DATE	02/06/2014
CHECKED	JENNA BECKER
DATE	02/06/2014

COMMENTS:

N/A

SCALE: 4:1

TITLE:

SUPPORT BEARING

SIZE	DWG. NO.	REV
A	AA104	0

NEXT ASSY: TA003

SHEET 1 OF 1

5

4

3

2

1

ADAPTIVE BASKETBALL SHOOTER



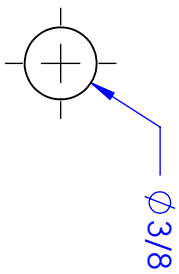
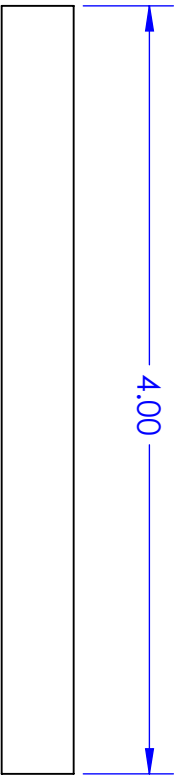
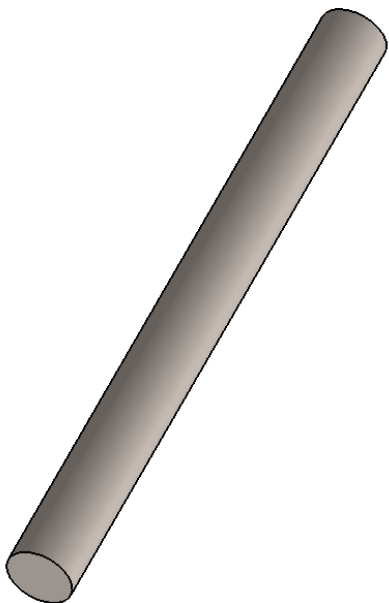

UNLESS OTHERWISE SPECIFIED:

DIMENSIONS ARE IN INCHES
TOLERANCES:
FRACTIONAL: +1/32
TWO PLACE DECIMAL: ±0.015
THREE PLACE DECIMAL: ±0.005

WEIGHT 0.12 LB

MATERIAL 1144 MEDIUM
CARBON STEEL
FINISH N/A

DO NOT SCALE DRAWING

DRAWN RICHARD GALANTI

DATE 02/06/2014

CHECKED BRETT NAYUDU

DATE 02/06/2014

COMMENTS:

N/A

SCALE: 1:1

TITLE:

PULLEY SHAFT

SIZE DWG. NO.

A AA105

REV

0

NEXT ASSY: TA003

SHEET 1 OF 1



ADAPTIVE BASKETBALL SHOOTER

5

4

3

2

1

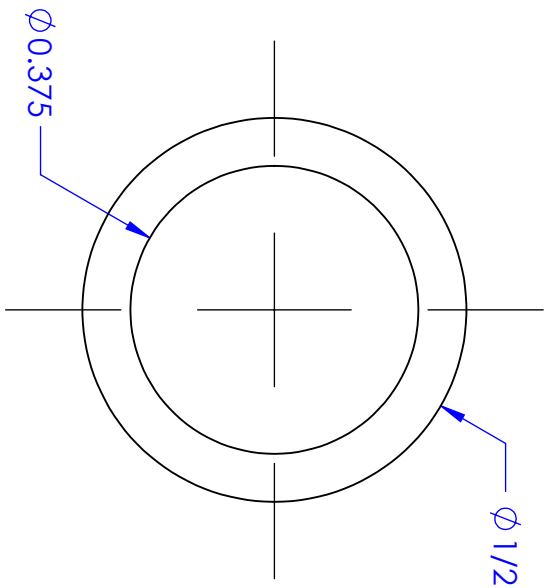
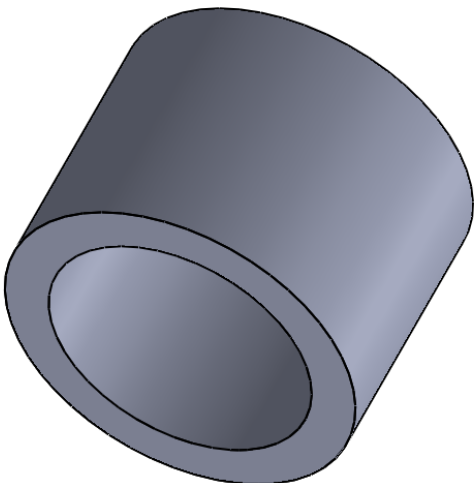

UNLESS OTHERWISE SPECIFIED:

DIMENSIONS ARE IN INCHES
 TOLERANCES:
 FRACTIONAL: $\pm 1/32$
 TWO PLACE DECIMAL: ± 0.015
 THREE PLACE DECIMAL: ± 0.005

WEIGHT 0.002 LB

MATERIAL DELRIN

FINISH N/A

DO NOT SCALE DRAWING

TITLE:

PULLEY SPACER LEFT SHORT

DRAWN	JENNA BECKER
DATE	02/06/2014
CHECKED	RICHARD GALANTI
DATE	02/06/2014

COMMENTS:

N/A

SCALE: 4:1

SIZE DWG. NO. AA106

REV 0

NEXT ASSY: TA003

SHEET 1 OF 1



ADAPTIVE BASKETBALL SHOOTER

5

4

3

2

1

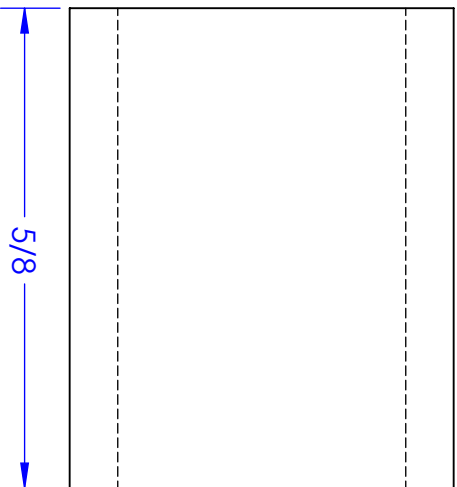
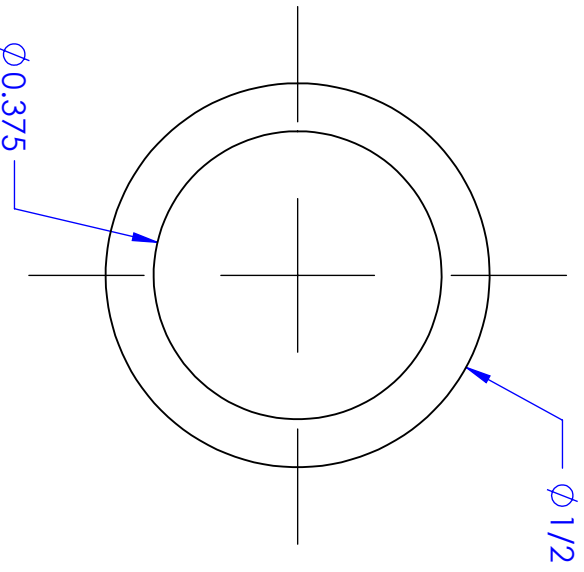
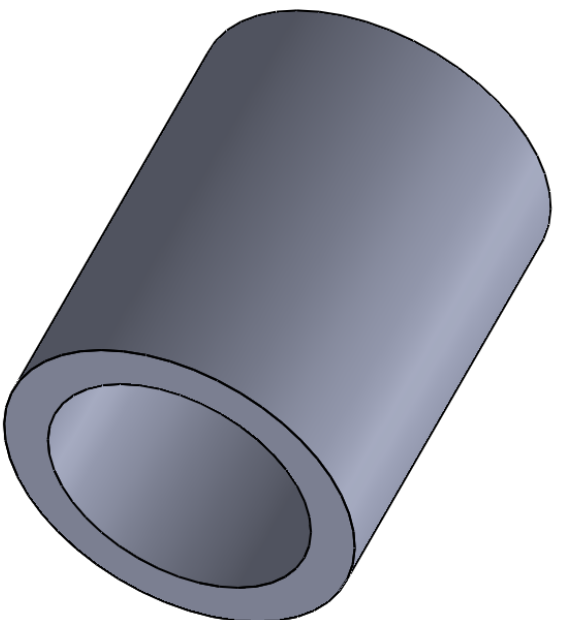

UNLESS OTHERWISE SPECIFIED:

DIMENSIONS ARE IN INCHES
 TOLERANCES:
 FRACTIONAL: +1/32
 TWO PLACE DECIMAL: ±0.015
 THREE PLACE DECIMAL: ±0.005

WEIGHT 0.003 LB

MATERIAL DELRIN

FINISH N/A

DO NOT SCALE DRAWING

DRAWN JENNA BECKER

DATE 02/06/2014

CHECKED XXXXXX

DATE RICHARD GALANTI

COMMENTS:

N/A

SCALE: 4:1

TITLE:

PULLEY SPACER LEFT LONG

SIZE DWG. NO.

A AA107

REV

0

NEXT ASSY: TA003

SHEET 1 OF 1



ADAPTIVE BASKETBALL SHOOTER

5

4

3

2

1

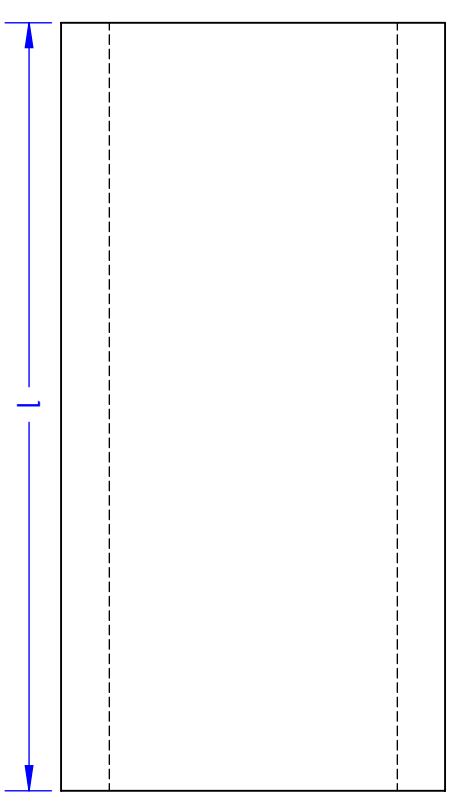
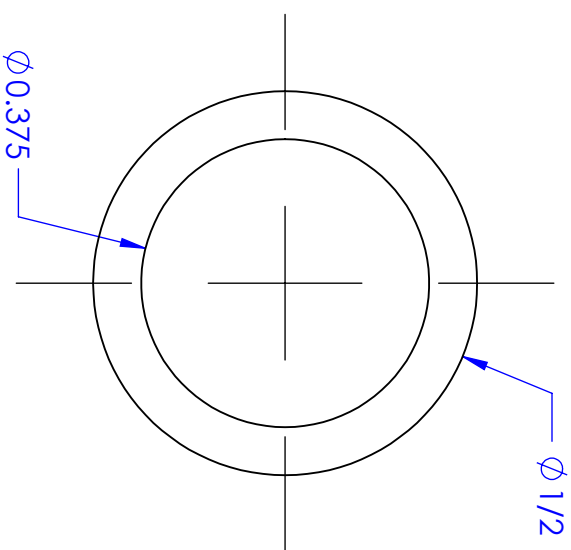
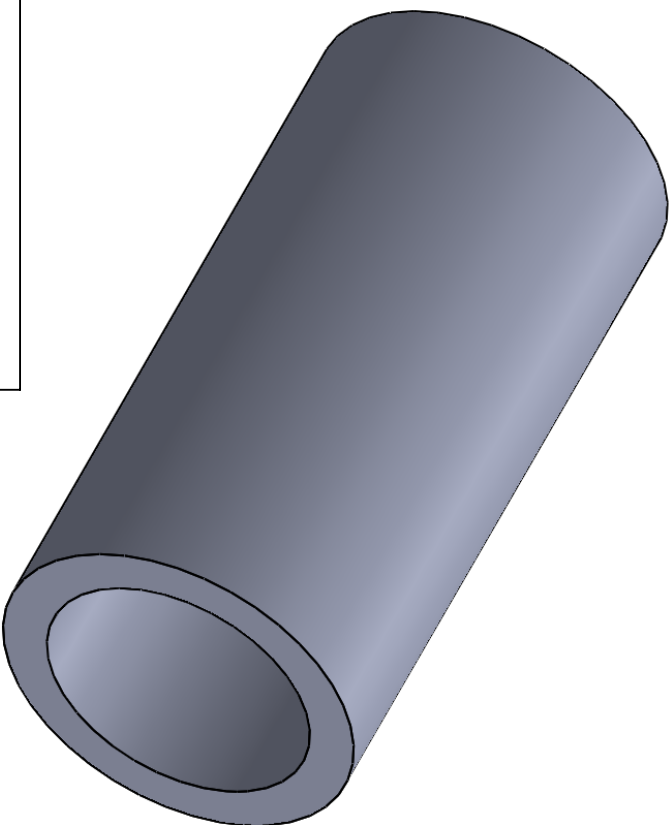

UNLESS OTHERWISE SPECIFIED:

DIMENSIONS ARE IN INCHES
 TOLERANCES:
 FRACTIONAL +1/32
 TWO PLACE DECIMAL ±0.015
 THREE PLACE DECIMAL ±0.005

WEIGHT 0.004 LB

MATERIAL DELRIN

FINISH N/A

DO NOT SCALE DRAWING

DRAWN JENNA BECKER
 DATE 02/06/2014

CHECKED RICHARD GALANTI
 DATE 02/06/2014

COMMENTS:

N/A

SCALE: 4:1

TITLE:

PULLEY SPACER RIGHT LONG

SIZE DWG. NO. REV
A AA108 0

NEXT ASSY: TA003 SHEET 1 OF 1



ADAPTIVE BASKETBALL SHOOTER

5

4

3

2

1

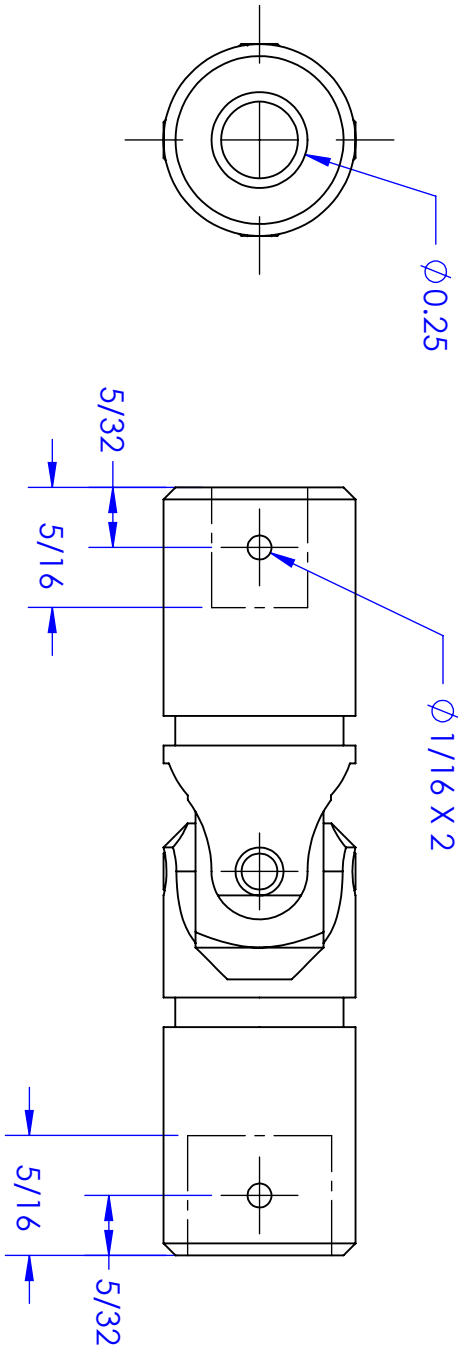
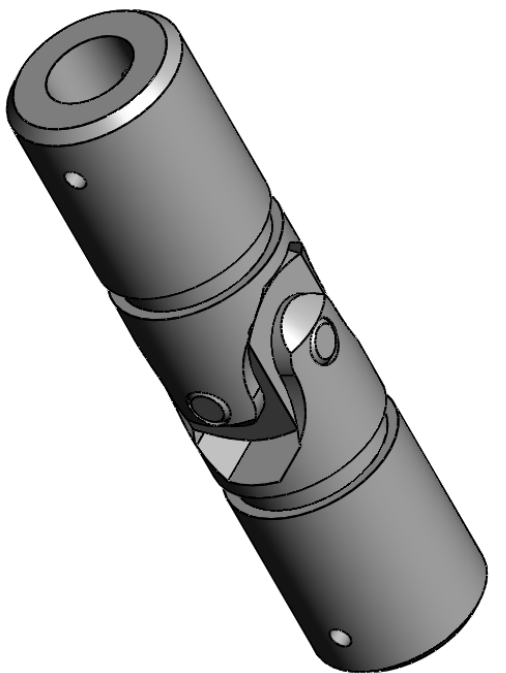

UNLESS OTHERWISE SPECIFIED:

DIMENSIONS ARE IN INCHES
 TOLERANCES:
 FRACTIONAL: $\pm 1/32$
 TWO PLACE DECIMAL: ± 0.015
 THREE PLACE DECIMAL: ± 0.005

WEIGHT 0.08 LB

MATERIAL STEEL

FINISH N/A

DO NOT SCALE DRAWING

DRAWN	JENNA BECKER
DATE	06/06/2014
CHECKED	RICHARD GALANTI
DATE	06/06/2014

COMMENTS:

UNIVERSAL JOINT IS BOUGHT OFF THE SHELF. ONLY THE HOLES DIMENSIONED NEED TO BE ADDED OR EXPANDED.

SCALE: 2:1

TITLE:

UNIVERSAL JOINT

SIZE	DWG. NO.	REV
A	AA109	1

NEXT ASSY: TA003

SHEET 1 OF 1



CAL POLY

ADAPTIVE BASKETBALL SHOOTER

5

4

3

2

1

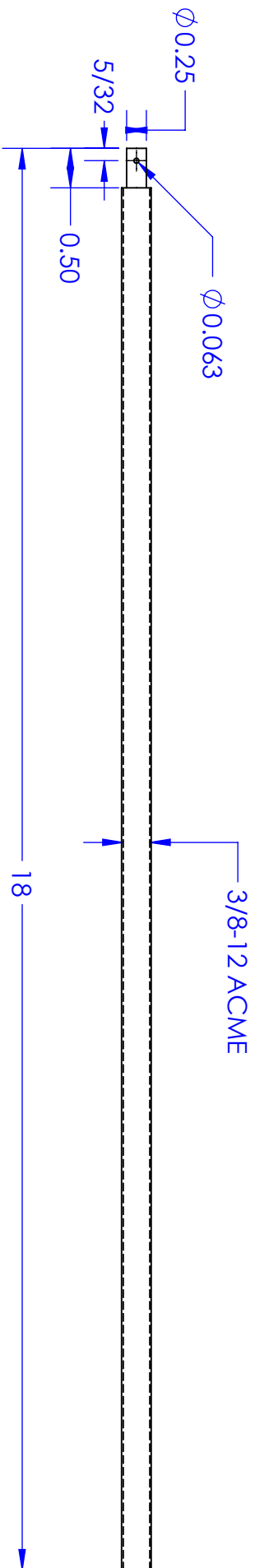
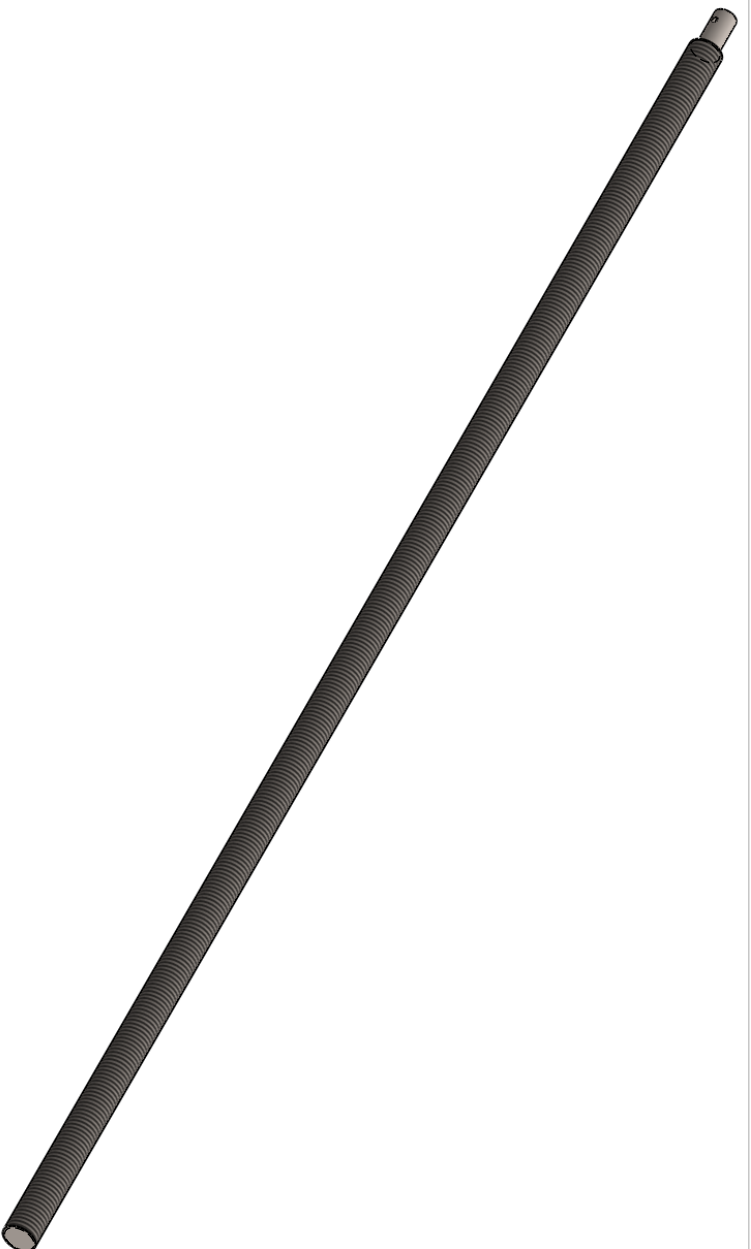

UNLESS OTHERWISE SPECIFIED:

DIMENSIONS ARE IN INCHES
 TOLERANCES:
 FRACTIONAL: +1/32
 TWO PLACE DECIMAL: ±0.015
 THREE PLACE DECIMAL: ±0.005

WEIGHT: 0.45 LB

MATERIAL: ALLOY STEEL

FINISH: N/A

DO NOT SCALE DRAWING

DRAWN: RICHARD GALANTI

DATE: 06/06/2014

CHECKED: BRETT NAYUDU

DATE: 06/06/2014

COMMENTS:

LEAD SCREW PURCHASED AND ALTERED BY TURNING DOWN ONE END AND DRILLING THE HOLE

TITLE:

LEAD SCREW

SIZE: A

DWG. NO.: AA110

NEXT ASSY.: TA003

REV: 1

SHEET 1 OF 1



ADAPTIVE BASKETBALL SHOOTER

5

4

3

2

1

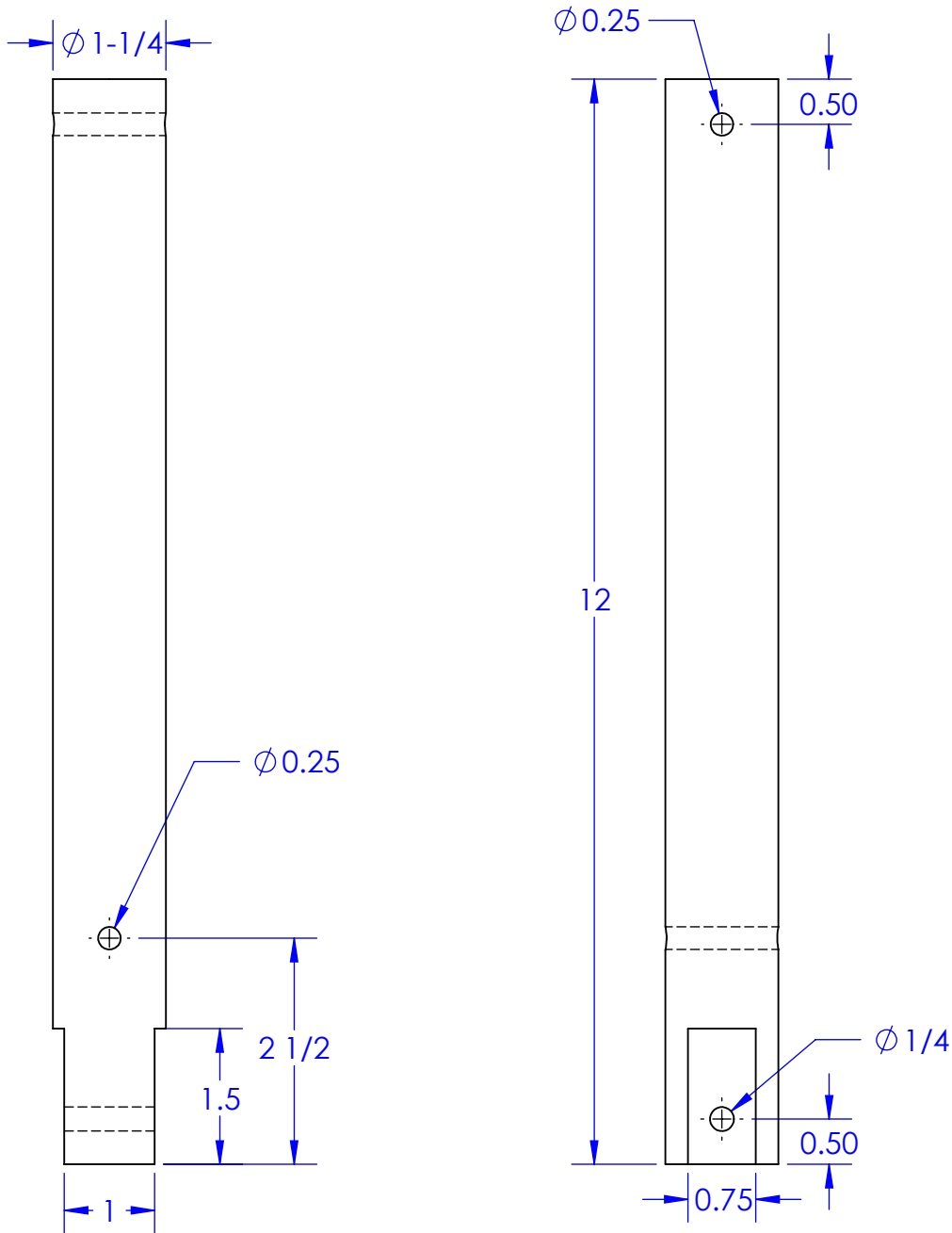

DIMENSIONS ARE IN INCHES
 TOLERANCES:
 FRACTIONAL: $\pm 1/32$
 TWO PLACE DECIMAL: ± 0.015
 THREE PLACE DECIMAL: ± 0.005

WEIGHT	0.73 LB
MATERIAL	DELRIN
FINISH	N/A
DO NOT SCALE DRAWING	

DRAWN	BRETT NAYUDU
DATE	06/06/2014
CHECKED	JENNA BECKER
DATE	06/06/2014
COMMENTS:	
ALL HOLES CENTERED ON SHAFT	

TITLE:		LEVER ARM	
SIZE	DWG. NO.		
A	AA111	REV.	1
SCALE: 1:2	NEXT ASSY: TA003	SHEET 1 OF 1	

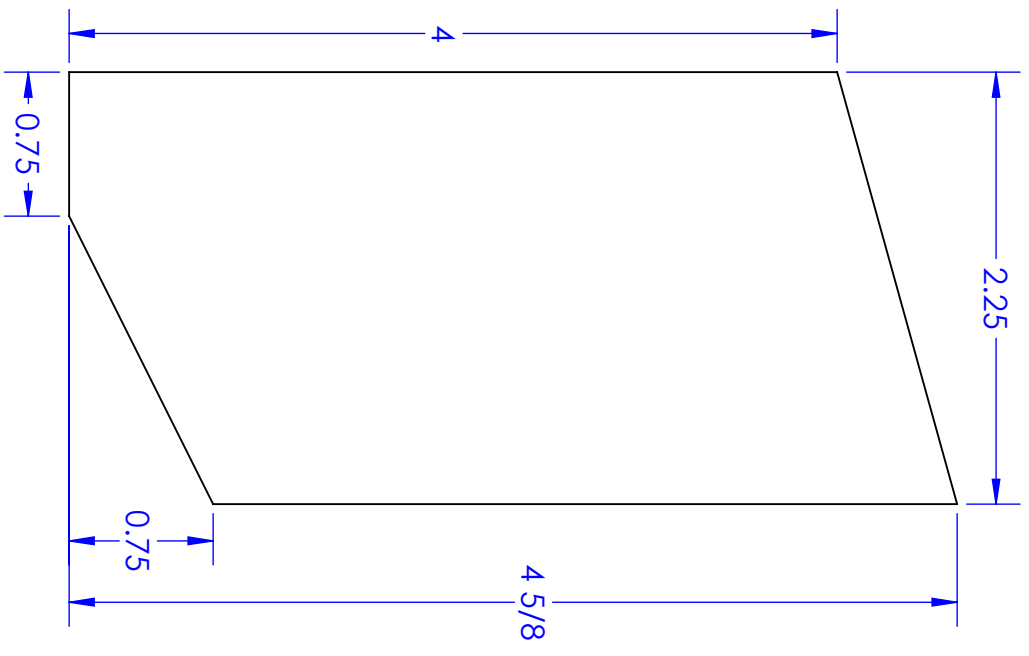

UNLESS OTHERWISE SPECIFIED:

DIMENSIONS ARE IN INCHES
 TOLERANCES:
 FRACTIONAL: +1/32
 TWO PLACE DECIMAL: ±0.015
 THREE PLACE DECIMAL: ±0.005

WEIGHT: 0.03 LB

MATERIAL: POLYCARBONATE

FINISH: N/A

DO NOT SCALE DRAWING

DRAWN	JENNA BECKER
DATE	06/06/2014
CHECKED	RICHARD GALANTI
DATE	06/06/2014
COMMENTS:	

SCALE: 1:1

TITLE:

AIMING SHIELD SIDE PLATE

SIZE	DWG. NO.	REV
A	AS101	0

NEXT ASSY: AA002 SHEET 1 OF 1

Mechanical Engineering
CAL POLY

ADAPTIVE BASKETBALL SHOOTER

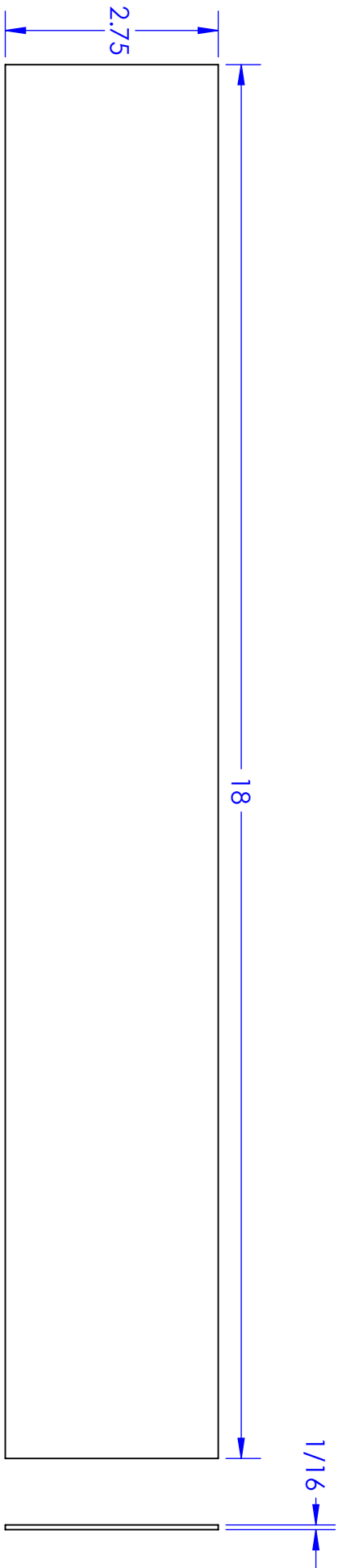

UNLESS OTHERWISE SPECIFIED:

DIMENSIONS ARE IN INCHES
 TOLERANCES:
 FRACTIONAL +1/32
 TWO PLACE DECIMAL ±0.015
 THREE PLACE DECIMAL ±0.005

WEIGHT 0.13 LB

MATERIAL POLYCARBONATE
 FINISH N/A

DO NOT SCALE DRAWING

DRAWN	JENNA BECKER
DATE	06/06/2014
CHECKED	RICHARD GALANTI
DATE	06/06/2014

COMMENTS:

N/A

SCALE: 1:2

TITLE:

AIMING SHIELD TOP PLATE

SIZE	DWG. NO.
A	AS102

NEXT ASSY: AA002

REV
0

SHEET 1 OF 1



ADAPTIVE BASKETBALL SHOOTER

5

4

3

2

1

ITEM NO.	PART NUMBER	DESCRIPTION	QTY.
1	AS101	AIMING SHIELD SIDE PLATE	2
2	AS102	AIMING SHIELD TOP PLATE	1

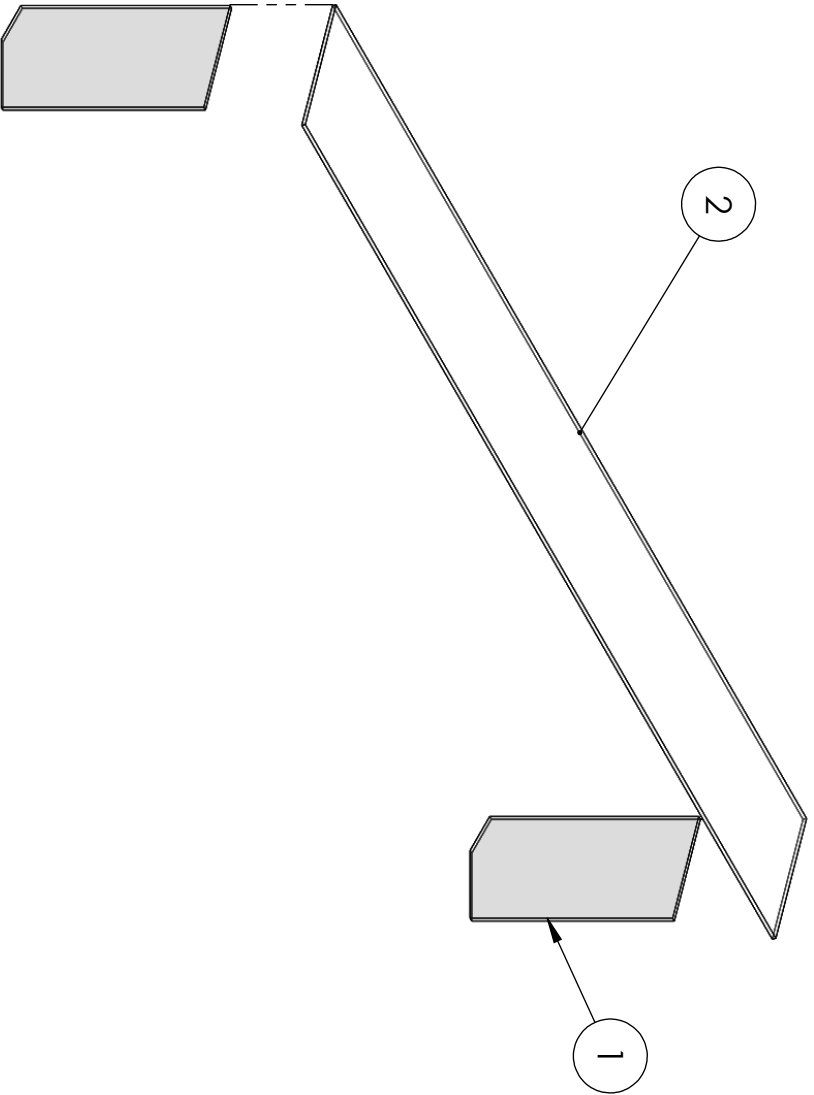

UNLESS OTHERWISE SPECIFIED:

DIMENSIONS ARE IN INCHES
 TOLERANCES:
 FRACTIONAL: +1/32
 TWO PLACE DECIMAL: ±0.015
 THREE PLACE DECIMAL: ±0.005

WEIGHT 0.18 LB

MATERIAL POLYCARBONATE

FINISH N/A

DO NOT SCALE DRAWING

DRAWN	JENNA BECKER
DATE	06/06/2014
CHECKED	RICHARD GALANTI
DATE	06/06/2014

COMMENTS:

ALL PIECES ARE BONDED TOGETHER USING A SILICONE ADHESIVE

SCALE: 1:3

TITLE:

AIMING SHIELD

SIZE DWG. NO. REV
A AA002 **0**

NEXT ASSY: TA003 SHEET 1 OF 1



ADAPTIVE BASKETBALL SHOOTER

5

4

3

2

1

ITEM NO.	PART NUMBER	DESCRIPTION	QTY.
1	AA001	TABLE TOP ASSEMBLY	1
2	6473K76	CRANK HANDLE	1
3	1755A32	LEVER BRACKET	1
4	6391K172	TABLE TOP SLEEVE BEARING	3
5	AA103	SUPPORT PLATE	1
6	8809T62	L BRACKET	4
7	AA104	SUPPORT BEARING	3
8	AA105	PULLEY SHAFT	3
9	AA107	PULLEY SPACER LEFT LONG	1
10	AA106	PULLEY SPACER LEFT SHORT	1
11	AA108	PULLEY SPACER RIGHT LONG	1
12	6495K24	12-TOOTH PULLEY	2
13	6495K23	10-TOOTH PULLEY	2
14	6484K113	TIMING BELT	2
15	6443K27	UNIVERSAL JOINT	2
16	AA110	LEAD SCREW	2
17	AA111	LEVER ARM	1
18	AA002	AIMING SHIELD	1

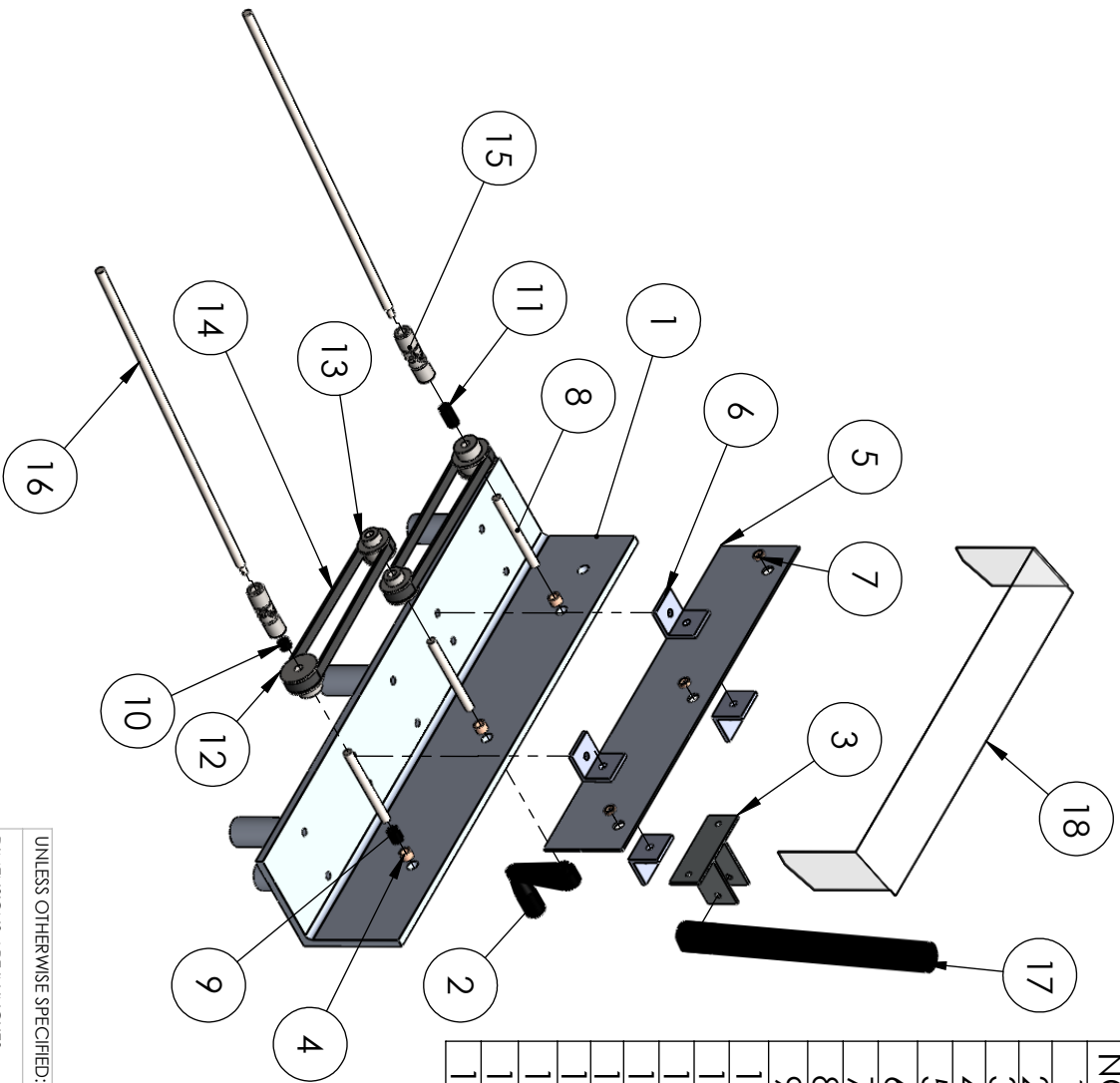

UNLESS OTHERWISE SPECIFIED:

DIMENSIONS ARE IN INCHES
TOLERANCES:
FRACTIONAL $\pm 1/32$
TWO PLACE DECIMAL ± 0.015
THREE PLACE DECIMAL ± 0.005

WEIGHT 17.4 LB

MATERIAL VARIOUS

FINISH N/A

DO NOT SCALE DRAWING

UNLESS OTHERWISE SPECIFIED:		DRAWN	
DATE	06/06/2014	JENNA BECKER	
CHECKED	RICHARD GALANTI		
DATE	06/06/2014		

COMMENTS:

SUPPORT BEARINGS PRESS FIT INTO SUPPORT PLATES. BOLTS AND SET SCREWS NOT SHOWN

SCALE: 1:8

TITLE:

AIMING ASSEMBLY

SIZE DWG. NO. REV
A TA003 1

NEXT ASSY: TA004

SHEET 1 OF 1

Engineering
CAL POLY

ADAPTIVE BASKETBALL SHOOTER

ITEM NO.	PART NUMBER	DESCRIPTION	QTY.
1	UPF001	UPF ASSEMBLY	1
2	TA001	FRAME ASSEMBLY	1
3	TA002	RATCHET ARM ASSEMBLY	1
4	TA003	AIMING ASSEMBLY	1

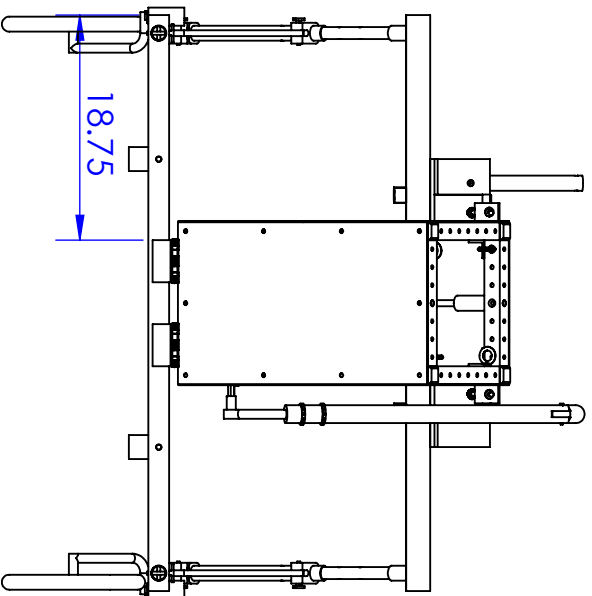
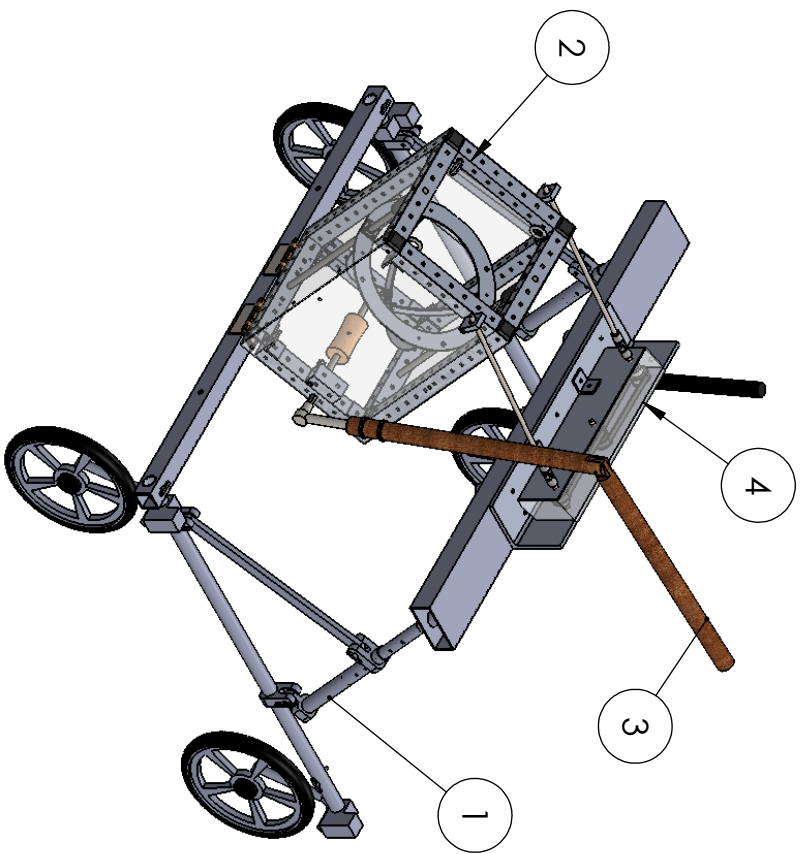

UNLESS OTHERWISE SPECIFIED:

DIMENSIONS ARE IN INCHES
TOLERANCES:
FRACTIONAL: +1/32
TWO PLACE DECIMAL: ±0.015
THREE PLACE DECIMAL: ±0.005

WEIGHT 67.2 LB W/ UPF

MATERIAL VARIOUS

FINISH N/A

DO NOT SCALE DRAWING

DRAWN	JENNA BECKER
DATE	06/06/2014
CHECKED	RICHARD GALANTI
DATE	06/06/2014

COMMENTS:

UPF TABLE TOP MUST BE ADJUSTED TO HEIGHT SHOWN IN ORDER FOR ALL PARTS TO BE PROPERLY ASSEMBLED

TITLE:

TOTAL ASSEMBLY

SIZE	DWG. NO.
A	TA004

REV	1
-----	---

NEXT ASSY: N/A

SHEET 1 OF 1



ADAPTIVE BASKETBALL SHOOTER

5

4

3

2

1

Appendix F – Operation and Safety Manual

The following pages contain a manual for the safe set-up and operation of this device. This manual will be given to the kinesiology students that are in charge of overseeing the device's use.

User Manual and Safety Guide

To ensure the safety of all who use this device, and to maximize the effectiveness of the device, it is important that it is used properly.

Assembly

The first step is to assemble the device, which includes assembling the UPF. It is easiest to place the aiming sub-assembly on the tabletop of the UPF first, making sure that the lead screws are relaxed and out of the way.

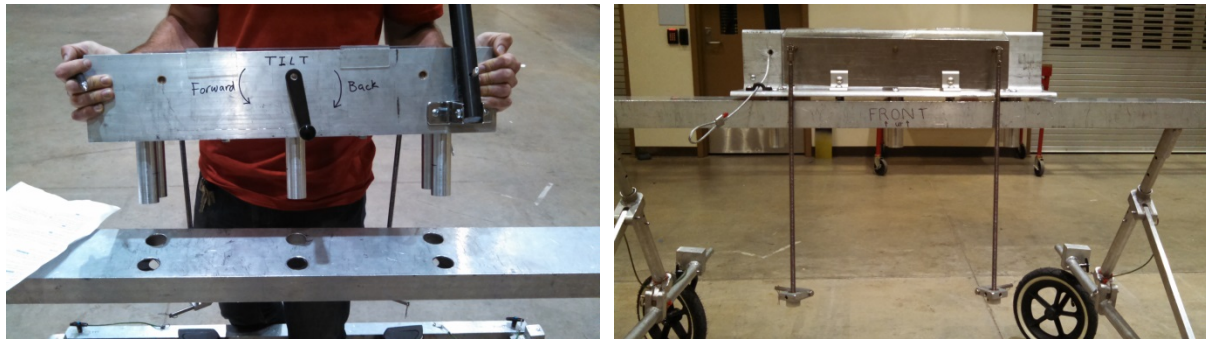

Then the frame can be placed upon the front bar of the UPF, in the center of the lead screws. This is easiest to do at an angle, as shown below.



Disassembly note: it is much easier to take it off at an angle too, since the weight of the frame puts torque on the front bar.

Attach the lead screw hinges to the frame by removing the pins, having the pin hole side down, having the hinge flush against the frame, and then inserting the pins from the frame to the hinge, and placing the hitch back in the pin.

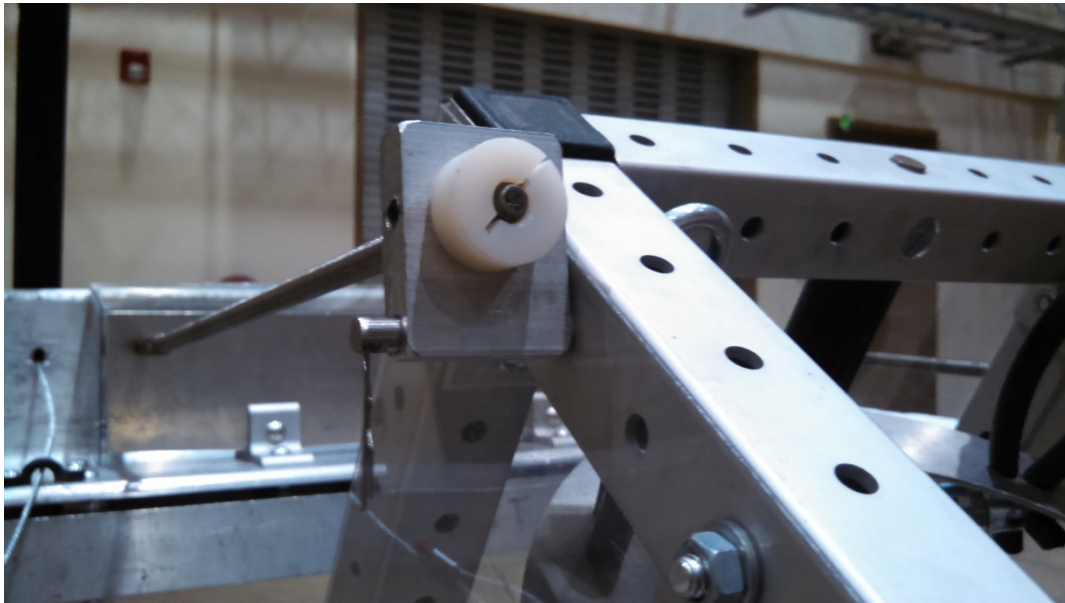

Now the assembly is complete!

Launching

Step 1: Place the basketball in the launcher. Open latch door, make sure quick release is attached and pawl is engaged with the ratchet. This may require unwinding of the rope from the winch shaft.



When the release lever has been fully pulled, there will not be enough slack in the release cable to reattach the quick release. Put the release lever upright and pull the cable all the way to the end so there is enough slack.



Close latch door.

Step 2: Make sure nobody is in front of the device. Place the ratchet arm on the hex-head bolt on the side of the frame. The ratchet will rotate the winch shaft and wind the rope around it when the ratchet arm is pushed forward and back. The ratchet arm may be used by the athlete if he has the capability of pulling and pushing it forward; if not, the second half of the ratchet arm detaches so it may be easier for the assistant to crank it back.



Step 3: Pull it back to the desired distance, but no farther than the metal stops on the rope as shown below. Next, attach the karabiner to the cable loop as shown below. Once attached, pull the release lever steadily until the ball launches.

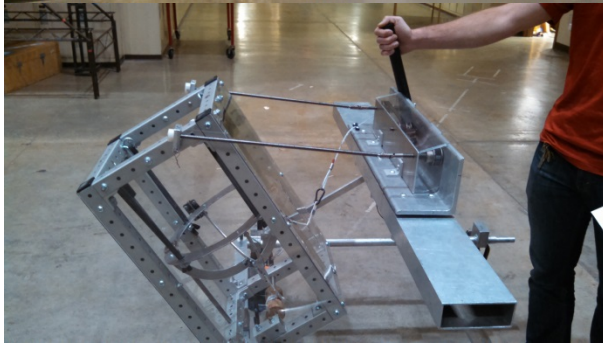
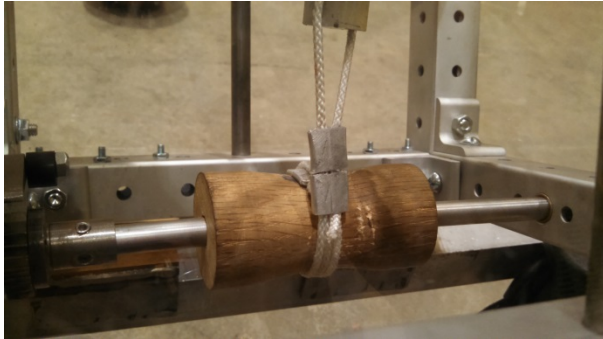

Safety

In the case of a jam in the launch of the basketball, where the release pin has been pulled but the carriage does not move, the winch shaft can be reverse cranked with the help of two people. One person will pull on the ratchet arm to disengage the ratchet from the pawl, and the other person will use the steel shaft to push the pawl out of the way to unwind the shaft by a small amount, and then re-engage the pawl so that the carriage does not release all of its energy at once. Repeat this process until the elastic is in the resting position.

