



THE UNIVERSITY *of* EDINBURGH

Edinburgh Research Explorer

Recent advances in liquid and gas chromatography methodology for extending coverage of the metabolome

Citation for published version:

Haggarty, J & Burgess, KEV 2017, 'Recent advances in liquid and gas chromatography methodology for extending coverage of the metabolome', *Current opinion in biotechnology*, vol. 43, pp. 77-85.
<https://doi.org/10.1016/j.copbio.2016.09.006>

Digital Object Identifier (DOI):

[10.1016/j.copbio.2016.09.006](https://doi.org/10.1016/j.copbio.2016.09.006)

Link:

[Link to publication record in Edinburgh Research Explorer](#)

Document Version:

Publisher's PDF, also known as Version of record

Published In:

Current opinion in biotechnology

General rights

Copyright for the publications made accessible via the Edinburgh Research Explorer is retained by the author(s) and / or other copyright owners and it is a condition of accessing these publications that users recognise and abide by the legal requirements associated with these rights.

Take down policy

The University of Edinburgh has made every reasonable effort to ensure that Edinburgh Research Explorer content complies with UK legislation. If you believe that the public display of this file breaches copyright please contact openaccess@ed.ac.uk providing details, and we will remove access to the work immediately and investigate your claim.





Recent advances in liquid and gas chromatography methodology for extending coverage of the metabolome

Jennifer Haggarty and Karl EV Burgess

The metabolome is the complete complement of metabolites (small organic biomolecules). In order to comprehensively understand the effect of stimuli on a biological system, it is important to detect as many of the metabolites within that system as possible. This review briefly describes some new advances in liquid and gas chromatography to improve coverage of the metabolome, including the serial combination of two columns in tandem, column switching and different variations of two-dimensional chromatography. Supercritical fluid chromatography could provide complimentary data to liquid and gas chromatography. Although there have been many recent advancements in the field of metabolomics, it is evident that a combination, rather than a single method, is required to approach full coverage of the metabolome.

Address

Polyomics, University of Glasgow, 211 Wolfson Wohl Translational Cancer Research Centre, Garscube Campus, Glasgow G61 1QH, UK

Corresponding author: Burgess, Karl EV (karl.burgess@glasgow.ac.uk)

Current Opinion in Biotechnology 2017, 43:77–85

This review comes from a themed issue on **Analytical biotechnology**

Edited by **Jurre J Kamphorst** and **Ian A Lewis**

For a complete overview see the [Issue](#) and the [Editorial](#)

Available online 20th October 2016

<http://dx.doi.org/10.1016/j.copbio.2016.09.006>

0958-1669/© 2016 The Author(s). Published by Elsevier Ltd. This is an open access article under the CC BY license (<http://creativecommons.org/licenses/by/4.0/>).

Introduction

Metabolomics

Metabolites are small organic molecules that undergo biochemical modifications during metabolic reactions and are necessary for the correct growth, maintenance and function of living cells [1]. They are the direct result of regulatory processes and as such their concentrations serve as an indication of biochemical activity, and hence phenotype, which can be used to determine cellular response to stimuli [1,2]. Although metabolic analysis had been carried out previously, Oliver *et al.* were the first to describe the full complement of small molecules synthesised by an organism as the metabolome [3]. Ideally, metabolomics is the study of metabolic reactions through the identification and quantitation of all the metabolites, the metabolome, within a biological system

[4]. The ability to directly link metabolite concentrations to molecular activity has meant that metabolomics has become a powerful tool in cell and systems biology research [5].

Coverage of the metabolome

In order to comprehensively understand the effect of stimuli on a biological system, it is important to detect as many of the metabolites within that system as possible. It is estimated that there are around 2000 metabolites present in mammals and 200 000 in the plant kingdom [6,7]. The diversity in mass, concentrations, polarity, volatility, solubility, pK_a and charge of these metabolites creates analytical problems [8,9]. García-Cañaveras *et al.* described the metabolomics concept as ‘the unbiased determination of all the metabolites present in a sample independently of their chemical structure’ [10]. However, the analytical platforms used to detect these compounds tend to exploit specific chemical characteristics of different classes of metabolites.

Metabolomics techniques

The most widely utilised analytical platform in metabolomics is based on mass spectrometry (MS) detection [11]. To improve sensitivity and resolution of metabolite detection, liquid chromatography (LC) and gas chromatography (GC) separation techniques are commonly coupled to a mass spectrometer [1,11].

LC–MS can be applied to the analysis of the majority of chemical species. Innovations in LC technology, instrumentation, and column chemistries have led to wider coverage of the metabolome. Although reverse phase (RPLC) is better suited for the analysis of nonpolar compounds, due to its ease of use and wide ranging applicability, it is the most commonly used method in LC for metabolic analysis. To improve the retention of polar metabolites ion-pairing agents are often added to the mobile phase, but these can have significant ion suppression effects on mass spectrometry instrumentation, leading to a far more restricted range of available ion pairs than for chromatography as a whole [12].

GC–MS has long been used in the analysis of metabolites and metabolite profiling due to its separation capacity, sensitivity and selectivity [8,13]. GC–MS requires chemical derivatisation to improve the volatility and thermal stability of polar compounds [14,15]. Developments in column stationary phases (SPs) and methods for sample preparation have increased the number of metabolites

detectable by GC–MS [8^{*}]. For example, ionic liquid SPs exhibit a ‘dual-nature’ allowing the separation of polar and nonpolar compounds as well as extending the temperature range at which the column can be operated [16].

This review will focus on the recent advancements in LC–MS and GC–MS to extend the coverage of the metabolome, with a focus on the innovation of dual-column methods in LC and GC.

LC–MS methods

In any chromatographic analysis, a compromise must be achieved between column efficiency and analysis time. There have been many recent developments that improve efficiency and/or throughput in LC, either

through optimisation of single columns or through the combination of multiple columns. Many of these can be applied to analysis of metabolites.

Single column methods

Although there have been many advancements in single column technologies, this review will focus on dual column methods as an in-depth review discussing the most recent approaches using single columns has been published by Fekete *et al.* [17^{**}].

Although there have been extraordinary advancements, it is likely that a single column method is insufficient for the analysis of the entire metabolome due to the chemical diversity exhibited by metabolites. The combination of

Figure 1

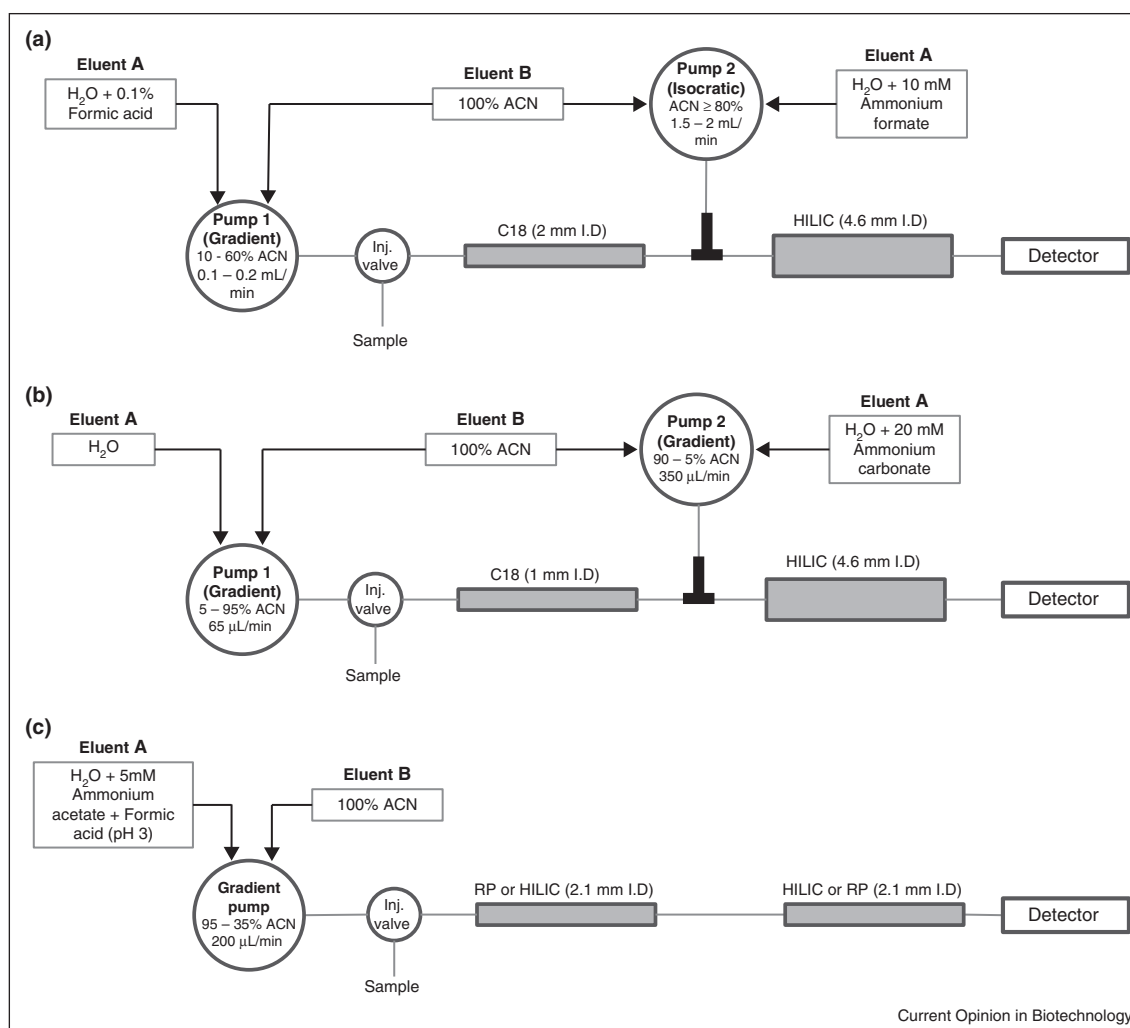

Examples of serially combined (SCC) methods. **(a)** Isocratic pump (pump 2) joined via a t-piece to the system to deliver a high concentration of organic solvent before the HILIC column. This is run at a higher flow rate to increase the organic concentration of the eluent before the HILIC column [19]. **(b)** Two gradient pumps incorporated into the system for individual control of the mobile phase compositions [21]. **(c)** Two orthogonal columns serially combined without the addition of a second pump. The gradient pump is run under ‘HILIC-style’ conditions which allow the coupling of two orthogonal columns. The columns can be combined in any order [24].

orthogonal columns can increase the coverage of the metabolome [18]. However running two different chromatographies in parallel doubles the time it takes to prepare samples and run analyses. Alternative methods have been developed in LC-MS to overcome this issue.

Serially combined method

The serial combination of two different columns is a relatively simple method that can increase the number of metabolic features that can be separated in one chromatographic run (Figure 1) [19–21]. Different column chemistries and lengths can be coupled, with column pairing usually based on their orthogonality and MP compatibility [22•]. RPLC and hydrophilic interaction liquid chromatography (HILIC) can provide powerful complementary data and have been coupled in various

studies for the targeted retention and separation of polar and nonpolar metabolites in various samples [19,23]. Haggarty *et al.* and Chalcraft *et al.* demonstrated the applicability of the combined RP-HILIC method to untargeted metabolomics for the detection of polar and nonpolar analytes in a complex sample [21,24]. It has even been shown that serially combined columns can behave as a new column with increased retention of compounds that show poor retention on two individual columns [25]. A comprehensive review of serially combined columns and their applications has recently been published by Alvarez-Segura *et al.* [22•].

Serially combined methods utilise conventional equipment, without the need for dedicated switching valves, are simple to set-up, require no specialist training, reduce

Figure 2

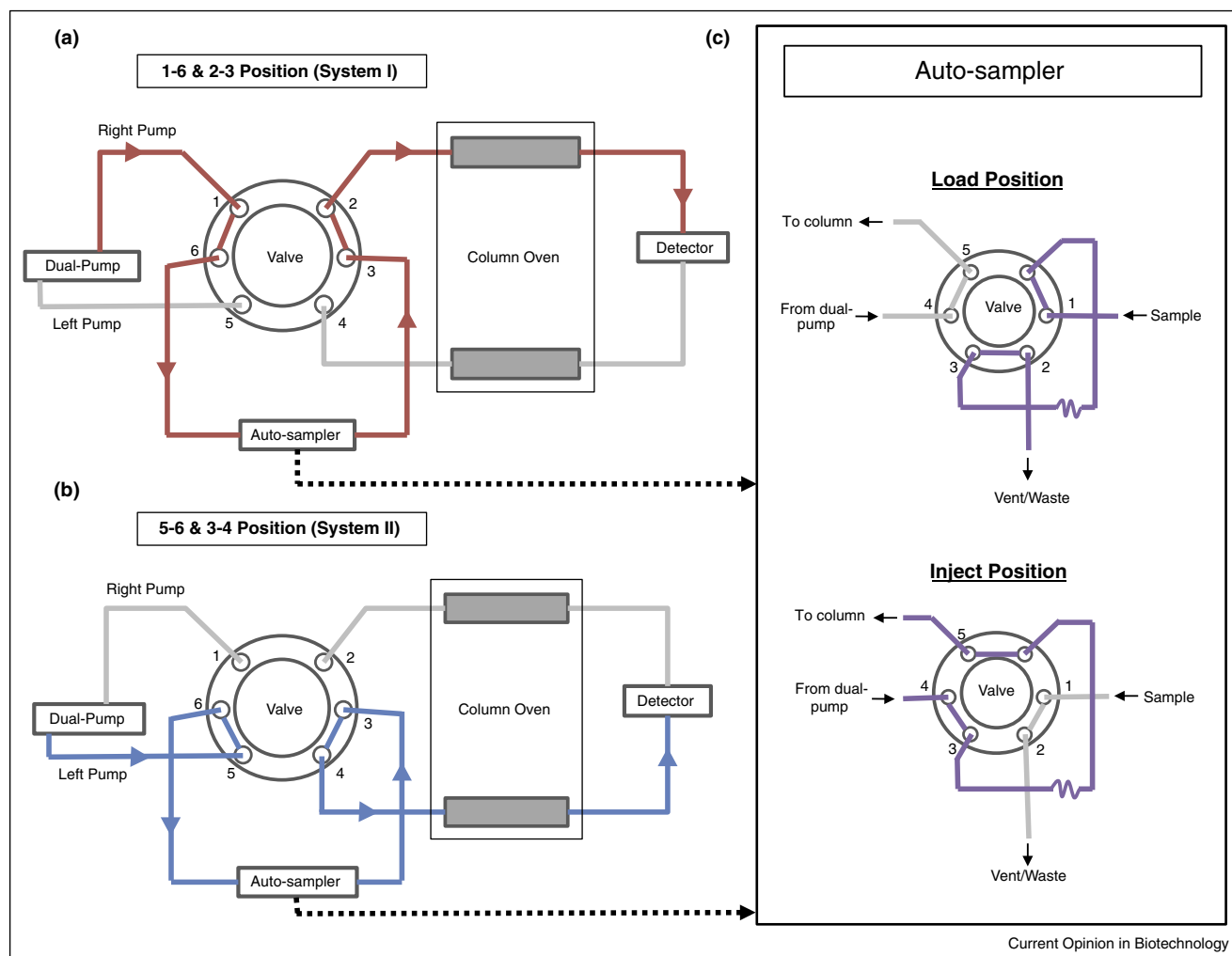

Schematic of the novel column switching method developed by Li *et al.* (2015) that incorporates a six-port switching valve. The system shares a column oven, auto-sampler and detector. (a) In the 1-6/2-3 position the sample is injected on to the first column using the right pump (system I). (b) When the valve switches to positions 5-6/3-4 the sample is injected on to the second column using the left pump (system II) [30]. (c) In the load position, the auto-sampler loads the sample onto a sample loop ready for injection from either the right pump (system I) or the left pump (system II).

analysis time and the column set-up can be disassembled and re-used when needed [22^{••}]. However, as well as the need for elution condition compatibility of the selected columns, the limited length selection and high cost of different manufacturer's columns and lack of commercially available software to determine the best column combinations and separation conditions, contribute to the limiting factors of this method [22^{••}].

Column switching

In column switching, a six-port or ten-port valve is connected to two separate pumps and columns. A sample is loaded into the valve and is run through the first column. The valve then switches and a second injection from the same sample is introduced to the second system. Samples can be run on two different columns in one analytical run. Column switching techniques have been applied to the analysis of pesticide residue monitoring, food inspection, biochemical and drug analysis [26–29]. Recently an untargeted column-switching UHPLC-quadrupole time-of-flight (Q-TOF) MS method was developed for the analysis of metabolites and lipids in human plasma and rat livers (Figure 2) [30]. This method affords the possibility of running samples on two completely different LC SPs with incompatible MPs, enables rapid analysis, purification and enrichment of samples and can extend the coverage of the metabolome (when orthogonal columns

are used). However, one injection per column is required, and the need for dedicated switching systems, complicated and expensive system set-ups as well as specialist training means that this method may not be suitable for routine use in many laboratories.

Two dimensional LC (2D-LC)

There are two categories of 2D-LC methods. In the first, comprehensive 2D-LC, the entire effluent is run on the first column, collected in aliquots, and then all of the fractions are injected onto the second column with very short gradients run on both dimensions [31]. In the second method, termed heart-cutting 2D-LC, fractions are collected from the first dimension and only a select few, those containing the metabolites of interest, are then run on the second dimension with longer gradients than those used in comprehensive 2D-LC [31]. The transfer of the effluent from the first to the second dimension can be carried out off-line or on-line (automated) using a dedicated switching valve (Figure 3). François *et al.* have published a detailed review of the technical aspects of comprehensive 2D-LC [31].

To improve peak capacity in 2D-LC, UHPLC and high temperature (HT)-UHPLC have recently been suggested for use in the second dimension [32[•]]. It has been demonstrated that the use of short UHPLC columns, com-

Figure 3

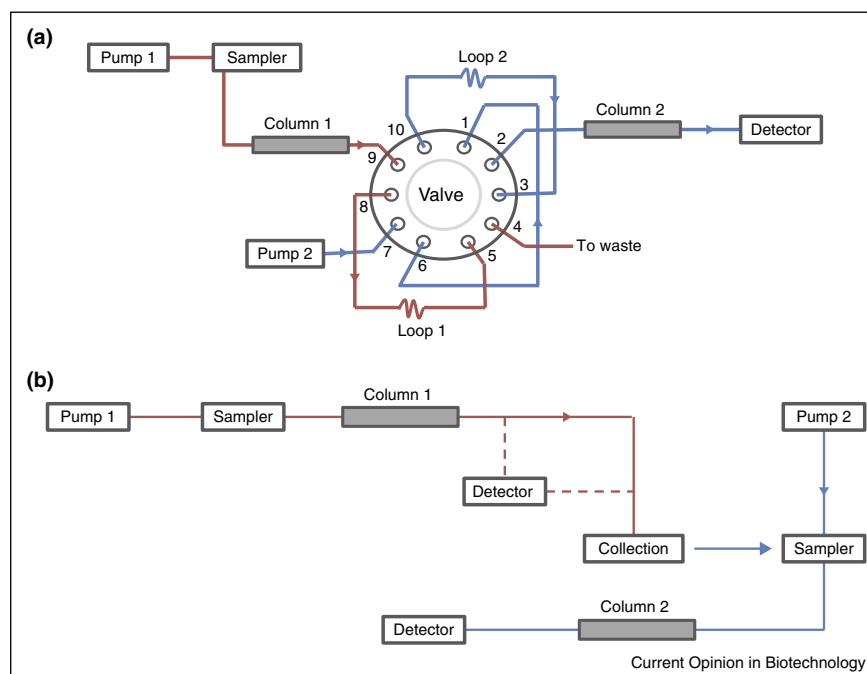

Typical configuration for 2D-LC separations. (a) An online set-up. The sample is injected onto the first dimension and can then be collected in a sample loop before it is introduced to the second column (or dimension) by switching the valve, allowing the other loop to be concomitantly filled. (b) Off-line 2D-LC set-up. The sample is analysed in the first dimension and is then manually transferred to a second system for second dimension analysis [55]. The sample can be introduced to the column and collected in fractions, with either the analysis path running through the detector or running to the collection plate without detection.

Table 1

Comparison of different analytical methods for metabolomics

Method	Column combinations and applications	Comments
Serially combined columns	<p><i>C18/Silica (HILIC)</i> – sugars and sulphonamides in pharmaceuticals [19]</p> <p><i>BEH C18/Silica (HILIC)</i> – arylamines and aminopyridines in pharmaceuticals [19]</p> <p><i>EC-C18/ZIC-HILIC</i> – polar and nonpolar phenols in wine [20]</p> <p><i>C18/ZIC-pHILIC</i> – bile acid and TCA intermediates, polar and nonpolar metabolites in beer [21]</p> <p><i>ZIC-HILIC/RP-amide</i> or <i>RP-amide/ZIC-HILIC</i> – polar and nonpolar metabolites in mouse serum [24]</p>	<p><i>Advantages</i> – easy set-up, no specialist training required, no specialist equipment.</p> <p><i>Limitations</i> – lack of variety and expense of column lengths. No dedicated software. MPs must be compatible. Some set-ups there is no independent control over each gradient.</p>
Column switching	<p><i>C18 × C18</i> – carbamate and pyrethroid insecticide monitoring in water [26]</p> <p><i>Guard Cartridge RP-18e × C18</i> – β-carotene in food supplements [27]</p> <p><i>C8 × phenyl-hexyl/phenyl-hexyl</i> – folic acid and its derivatives in human plasma [28]</p> <p><i>C8 × C18</i> – quantification of monohydroxybutenylmercapturic acid (MHBMA), <i>N</i>-acetyl-S-(3,4-dihydroxybutyl) cysteine (DHBMA) and 8-hydroxy-2-deoxyguanosine (8-OHdG) in human urine [29]</p> <p><i>BEH C18 × HSS T3</i> – untargeted analysis of metabolites and lipids in human plasma and rat livers [30]</p>	<p><i>Advantages</i> – ability to combine two completely different LC separation platforms. Incompatible MPs are not an issue.</p> <p><i>Limitations</i> – specialist switching interface required, expensive equipment, specialist training required, one sample is injected on to one column but does not pass through the second column – two injections are required for one full analysis.</p>
2DLC	<p><i>HILIC × C18-UHPLC</i> – analysis of a variety phenolic compounds (including monomeric flavonoids, phenolic acids, coumarins and flavan-3-ols) in unfermented and fermented rooibos samples [52]</p> <p><i>Cyano column × C18-UHPLC</i> – separation of carotenoids in chilli peppers [53]</p> <p><i>RPLC × HT-RP-UHPLC</i> (variety of silica-based and non silica-based column combinations studied) – separation of standard mix of bio-oils [54]</p>	<p><i>Advantages</i> – ability to combine two completely different LC separation platforms. Incompatible MPs are not an issue.</p> <p><i>Limitations</i> – specialist switching interface required, expensive equipment, issues with sample dilution, specialist training required, second dimension analysis can be lengthy, creates more complexity than a 1D system so twice as likely for something to go wrong.</p>
2DGC	<p><i>Low polarity phase column × midpolarity phase column</i> – untargeted analysis for the detection of volatile organic compounds (VOCs) in human volatome. Over 2000 VOCs were detected [43]</p> <p><i>Low polarity phase column × midpolarity phase column</i> – untargeted analysis of plasma. Over 100 metabolites were detected, including TCA intermediates, carbohydrates, amino acids and fatty acids [44]</p> <p><i>GC × 2GC-MS/FID</i> – <i>Nonpolar phase column × 2 midpolarity phase columns</i> – <i>n</i>-alkane mix and other standards used for system evaluation, <i>Artemisia umbelliformis</i> tested for untargeted method [45]</p>	<p><i>Advantages</i> – powerful tool for identification of unknown compounds, increases peak capacity compared to 1DGC.</p> <p><i>Limitations</i> – flow mismatch makes analysis less efficient, specialist switching interface required, expensive equipment, specialist training required, creates more complexity than a 1D system so twice as likely for something to go wrong.</p>

Table 1 (Continued)

Method	Column combinations and applications	Comments
Super critical fluid chromatography	UHPSFC (Zorbax RX-Sil column, Agilent Technologies) – separation of sulphonamide drugs [50] 2DSFC – nonpolar phase column × polar phase column – separation of synthetic mix of hydrocarbons and coal derived vacuum distillate [49]	<i>Advantages</i> – uses less or no organic solvent so cheaper and more environmentally friendly than HPLC. Quicker, more efficient separations than HPLC, large molecule range which includes non-volatile metabolites, no derivatisation required, can be used to analyse thermally unstable compounds, ability to use range of detectors as SFC can be liquid or gas-like, can separate chiral compounds, can use GC or HPLC columns. <i>Limitations</i> – highly polar molecules are not soluble in the MP, can only move a small amount of a large specimen on to the column (LC × SFC or 2DSFC can be used to overcome some of these limitations).

bined with conventional HPLC columns, can significantly increase peak capacity compared to 1D separation. HT-UHPLC could further improve capacity, however, the increased temperature may be detrimental to samples and instrumentation [33]. This method was recently applied to analysis of small peptides in both RPLC × RPLC and RPLC × HILIC conditions in both of the second dimensions. There was a 10-fold decrease in analysis time with a gain in peak capacity compared to the most efficient 1D separation of similar peptides published at that time [33].

Many different interaction mechanisms can be combined to increase capacity and improve the selectivity of the system [34]. One method utilised two different RP columns and applied a continually shifted gradient in the second dimension [35,36]. This method increased the orthogonality of the system by 43.7% and increased the effective peak distribution from 3320 to 4563 [36]. But as with other dual-column methods, combining two orthogonal mechanisms offers the best coverage [37,38,39]. The advantage of this technique is the ability to combine two different separation methods, with independent control over the eluent composition and pH, gradient program, flow-rate and temperature for each column [34]. The limiting factors of this method include equipment cost, the need for specialist knowledge and/or training, sample dilution and the lengthy analysis times (often days).

GC–MS methods

2D-GC

As with 2D-LC techniques 2D-GC combines two orthogonal columns together. A (thermal or pressure) modulator between the columns is used to periodically focus the effluent from the first column and transfer it to the second column in small concentrated segments [40]. Most 2D-GC metabolomics studies combine polar and mid-polar columns but polar and nonpolar columns have also been combined [41,42]. Philips *et al.* used 2D-GC TOF/MS to detect approximately 2000 volatile organic compounds in

human breath samples [43]. Bechstrom *et al.* identified 100 metabolites in plasma, with separation based on volatility in the first dimension and polarity in the second dimension [44].

Improvements to instrumentation have reduced flow mismatch when using thermal modulation and hence improved analyte identification and quantitation. Using a GC × 2GC-MS/flame ionisation detection (FID) the secondary column loading capacity was doubled, leading to improvements in overall system orthogonality and resolution [45].

Super critical fluid chromatography (SFC)

SFC utilises liquid CO₂ as a solvent (usually with a modifier) [46**] and is similar in nature to both HPLC and GC. The advent of newer more robust instrumentation and columns has allowed the progression of SFC to ultra-high performance SFC (UHPSFC) [47]. An extensive review of SFC has been published by Lesellier and West [46**]. The coupling of SFC to GC, LC and 2D-SFC is feasible [48,49]. 2D-SFC has already been applied to various studies [50,51].

All of the metabolomics techniques discussed in this review have been summarised in Table 1 for comparison.

Conclusions

The identification and quantitation of the full complement of metabolites within a biological sample is the ambitious goal of metabolomics. The number and physiochemical diversity of metabolites in existence creates huge analytical issues with regard to metabolome coverage. Innovations in various LC and GC single column technologies have resulted in improvements to the number of metabolites that can be detected using hyphenated MS methods. However, more than one analytical platform is required for the unbiased comprehensive detection of all metabolite species within a biological sample.

Each of the methods in this review has extended the coverage of the metabolome in terms of throughput, the number or variety of metabolites retained and separated by the system. Regardless of the analytical platform adopted, the possibility of using a single analytical method to profile a metabolome is unlikely due to the diverse chemistry of metabolites. However, new technologies such as higher resolution instruments, novel column chemistries, improved sample preparation and metabolite extraction methods, as well as new software and databases are rapidly emerging. We are now reaching the capability for a functional analysis of the metabolome by combining well-established methodologies, and by doing this, greater coverage of the metabolome can be achieved. Through numerous instrumental and technological advancements, metabolomics will truly reach its potential as an 'omics technique, providing a comprehensive analytical tool for the illumination of new insights into systems biology.

Conflict of interest

There are no conflicts of interest.

Acknowledgements

Jennifer Haggarty is supported by Engineering and Physical Sciences Research Council (EPSRC) (grant number EP/F500424/1) and Thermo Fisher Scientific. Glasgow Polyomics is supported by the Wellcome Trust (grant numbers 097821/Z/11/Z and 105614/Z/14/Z) and Glasgow University.

References and recommended reading

Papers of particular interest, published within the period of review, have been highlighted as:

- of special interest
- of outstanding interest

1. Dettmer K, Aronov PA, Hammock BD: **Mass spectrometry-based metabolomics**. *Mass Spectrom Rev* 2007, **26**:51-78.
 2. Fiehn O: **Metabolomics – the link between genotypes and phenotypes**. *Plant Mol Biol* 2002, **48**:155-171.
 3. Oliver SG, Winson MK, Kell DB, Baganz F: **Systematic functional analysis of the yeast genome**. *Trends Biotechnol* 1998, **16**:373-378.
 4. Blow N: **Biochemistry's new look**. *Nature* 2008, **455**:697-700.
 5. Johnson CH, Gonzalez FJ: **Challenges and opportunities of metabolomics**. *J Cell Physiol* 2012, **227**:2975-2981.
 6. Weckwerth W: **Metabolomics in systems biology**. *Annu Rev Plant Biol* 2003, **54**:669-689.
 7. Saito K, Matsuda F: **Metabolomics for functional genomics, systems biology, and biotechnology**. *Annu Rev Plant Biol* 2010, **61**:463-489.
 8. Wang Y, Liu S, Hu Y, Li P, Wan J-B: **Current state of the art of mass spectrometry-based metabolomics studies – a review focusing on wide coverage, high throughput and easy identification**. *RSC Adv* 2015, **5**:78728-78737.
 9. Forcisi S, Moritz F, Kanawati B, Tziotis D, Lehmann R, Schmitt-Kopplin P: **Liquid chromatography-mass spectrometry in metabolomics research: mass analyzers in ultra high pressure liquid chromatography coupling**. *J Chromatogr A* 2013, **1292**:51-65.
 10. García-Cañaveras JC, López S, Castell JV, Donato MT, Lahoz A: **Extending metabolome coverage for untargeted metabolite profiling of adherent cultured hepatic cells**. *Anal Bioanal Chem* 2016, **408**:1217-1230.
 11. León Z, García-Cañaveras JC, Donato MT, Lahoz A: **Mammalian cell metabolomics: experimental design and sample preparation**. *Electrophoresis* 2013, **34**:2762-2775.
 12. García MC, Hogenboom AC, Zappey H, Irth H: **Effect of the mobile phase composition on the separation and detection of intact proteins by reversed-phase liquid chromatography-electrospray mass spectrometry**. *J Chromatogr A* 2002, **957**:187-199.
 13. Greer M, Williams CM: **Diagnosis of branched-chain ketonuria (maple syrup urine disease) by gas chromatography**. *Biochem Med* 1967, **1**:87-91.
 14. Fiehn O, Kopka J, Dörmann P, Altmann T, Trethewey RN, Willmitzer L: **Metabolite profiling for plant functional genomics**. *Nat Biotechnol* 2000, **18**:1157-1161.
 15. Dunn WB, Broadhurst D, Ellis DI, Brown M, Halsall A, O'Hagan S, Spasic I, Tseng A, Kell DB: **A GC-TOF-MS study of the stability of serum and urine metabolomes during the UK Biobank sample collection and preparation protocols**. *Int J Epidemiol* 2008, **37**:23-30.
 16. Poole CF, Poole SK: **Ionic liquid stationary phases for gas chromatography**. *J Sep Sci* 2011, **34**:888-900.
 17. Fekete S, Veuthey JL, Guillaume D: **Comparison of the most recent chromatographic approaches applied for fast and high resolution separations: theory and practice**. *J Chromatogr A* 2015, **1408**:1-14.
- A summary of the advancements in available single column LC approaches. Both LC and SFC techniques are discussed and compared, along with examples of their applications from the literature. The review contains figures comparing different LC and SFC strategies in terms of efficiency versus throughput, giving the reader a clear and easily understood idea of what performance to expect from each individual method and their suitability depending on whether efficiency or throughput (or a compromise between both) is required for analysis. Silica-based monoliths have a great deal of potential, but the columns would need to be compatible with pressures up to 400–600 bar to compete with other LC methods. Columns packed with 5 µm SPP at 400 bar appear to give the highest resolution and the highest throughput was achieved using 1.3 µm SPP at 1000 bar. In SFC, columns packed with 2.7 µm SPP particles give the best compromise between resolution and throughput, but there has to be an improvement in SFC instrumentation to bring it in line with the performance of modern LC strategies. In agreement with the authors, although there have been advancements in single column technologies, 2D approaches appear to have more potential for extending the coverage metabolome.
18. Contrepois K, Jiang L, Snyder M: **Optimized analytical procedures for the untargeted metabolomic profiling of human urine and plasma by combining hydrophilic interaction (HILIC) and reverse-phase liquid chromatography (RPLC)-mass spectrometry**. *Mol Cell Proteomics* 2015, **14**:1684-1695.
 19. Louw S, Pereira AS, Lynen F, Hanna-Brown M, Sandra P: **Serial coupling of reversed-phase and hydrophilic interaction liquid chromatography to broaden the elution window for the analysis of pharmaceutical compounds**. *J Chromatogr A* 2008, **1208**:90-94.
 20. Greco G, Grosse S, Letzel T: **Serial coupling of reversed-phase and zwitterionic hydrophilic interaction LC/MS for the analysis of polar and nonpolar phenols in wine**. *J Sep Sci* 2013, **36**:1379-1388.
 21. Haggarty J, Oppermann M, Dalby MJ, Burchmore RJ, Cook K, Weidt S, Burgess KE: **Serially coupling hydrophobic interaction and reversed-phase chromatography with simultaneous gradients provides greater coverage of the metabolome**. *Metabolomics* 2015 <http://dx.doi.org/10.1007/s11306-014-0770-7>.
 22. Alvarez-Segura T, Torres-Lapasío JR, Ortiz-Bolsico C, García-Alvarez-Coque MC: **Stationary phase modulation in liquid chromatography through the serial coupling of columns: a review**. *Anal Chim Acta* 2016, **923**:1-23.
- A review which encompasses the theory of various approaches of coupling columns, with the main focus on serially combined columns

(SCC). The highlights include the advantages and limitations of SCC, optimisation of column nature and length and eluent composition, and the use of flow rate and temperature to control selectivity. Commercially available SCC, under the trademark PopLink[®] or POPLC[®] (the acronym POPLC comes from 'Phase Optimised Liquid Chromatography'), allows for different column lengths and different SPs to be connected together. However, issues with the tightness of the zero dead volume (ZDV) connectors create a lot of problems including retention time prediction, formation of fronting peaks and band broadening. Also the consumer is constrained to the column SPs and lengths dictated by the manufacturers of these systems. It is the opinion of the author that a simpler set-up using a T-piece to connect two columns is a suitable alternative; RPLC as the first separation and HILIC as the second, with the incorporation of two gradient pumps for independent control over each MP gradient has a great deal of potential for the simultaneous retention and separation of polar and nonpolar metabolites within one analytical run. However, optimisation of the method is required for the full potential of this technique to be achieved.

23. Chen J, Gao L, Li Z, Wang S, Li J, Cao W, Sun C, Zheng L, Wang X: **Simultaneous screening for lipophilic and hydrophilic toxins in marine harmful algae using a serially coupled reversed-phase and hydrophilic interaction liquid chromatography separation system with high-resolution mass spectrometry.** *Anal Chim Acta* 2016, **914**:117-126.
24. Chalcraft KR, McCarry BE: **Tandem LC columns for the simultaneous retention of polar and nonpolar molecules in comprehensive metabolomics analysis.** *J Sep Sci* 2013, **36**:3478-3485.
25. Alvarez-Segura T, Ortiz-Bolsico C, Torres-Lapasio JR, Garcia-Alvarez-Coque MC: **Serial versus parallel columns using isocratic elution: a comparison of multi-column approaches in mono-dimensional liquid chromatography.** *J Chromatogr A* 2015, **1390**:95-102.
26. Fernández-Ramos C, Šatínský D, Solich P: **New method for the determination of carbamate and pyrethroid insecticides in water samples using on-line SPE fused core column chromatography.** *Talanta* 2014, **129**:579-585.
27. Brabcova I, Hlavackova M, Satinsky D, Solich P: **A rapid HPLC column switching method for sample preparation and determination of β -carotene in food supplements.** *Food Chem* 2013, **141**:1433-1437.
28. Bailey SW, Ayling JE: **Differential coulometric oxidation following post column-switching high pressure liquid chromatography for fluorescence measurement of unmetabolized folic acid in human plasma.** *J Chromatogr A* 2013, **1315**:86-91.
29. Zhang X, Hou H, Chen H, Liu Y, Wang A, Hu Q: **A column-switching LC-MS/MS method for simultaneous quantification of biomarkers for 1,3-butadiene exposure and oxidative damage in human urine.** *J Chromatogr B Anal Technol Biomed Life Sci* 2015, **1002**:123-129.
30. Li Y, Zhang Z, Liu X, Li A, Hou Z, Wang Y, Zhang Y: **A novel approach to the simultaneous extraction and non-targeted analysis of the small molecules metabolome and lipidome using 96-well solid phase extraction plates with column-switching technology.** *J Chromatogr A* 2015, **1409**:277-281.
31. François I, Sandra K, Sandra P: **Comprehensive liquid chromatography: fundamental aspects and practical considerations — a review.** *Anal Chim Acta* 2009, **641**:14-31.
32. Sarrut M, Crétier G, Heinisch S: **Theoretical and practical interest in UHPLC technology for 2D-LC.** *Trends Anal Chem* 2014, **63**:104-112.

A review of 2D-LC, including the use of ultra-high-performance (UHPLC) and high temperature (HT) UHPLC in the second dimension. The application of UHPLC LC \times LC to various biological fields including food analysis, life sciences, bioenergy and polymers are discussed. It explains in a clear manner what parameters need to be considered to improve capacity and throughput in 2D-LC. It also demonstrates mathematically why UHPLC and HT-UHPLC are preferable techniques in the second dimension over conventional HTLC and HPLC. Interestingly the author suggests the use of parallel columns in the second dimension. However, it seems that this would further complicate an already quite complex system set-up with the addition of a second 10-port valve and also the data processing involved. 2D-LC with UHPLC or HT-UHPLC does appear to have a lot of potential in the field of metabolomics (possibly UHPLC

more than HT-UHPLC due to the thermal instability of some metabolites) as there are no issues with MP compatibility, meaning that many different separation platforms can be combined, as well as the achievement of higher peak capacity with the use of UHPLC, to extend coverage of the metabolome.

33. D'Attoma A, Heinisch S: **On-line comprehensive two dimensional separations of charged compounds using reversed-phase high performance liquid chromatography and hydrophilic interaction chromatography. Part II: application to the separation of peptides.** *J Chromatogr A* 2013, **1306**:27-36.
 34. Guiochon G, Marchetti N, Mriziq K, Shalliker RA: **Implementations of two-dimensional liquid chromatography.** *J Chromatogr A* 2008, **1189**:109-168.
 35. Bedani F, Kok WT, Janssen HG: **Optimal gradient operation in comprehensive liquid chromatography x liquid chromatography systems with limited orthogonality.** *Anal Chim Acta* 2009, **654**:77-84.
 36. Li D, Schmitz OJ: **Use of shift gradient in the second dimension to improve the separation space in comprehensive two-dimensional liquid chromatography.** *Anal Bioanal Chem* 2013, **405**:6511-6517.
 37. Jandera P: **Stationary phases for hydrophilic interaction chromatography, their characterization and implementation into multidimensional chromatography concepts.** *J Sep Sci* 2008, **31**:1421-1437.
 38. Cacciola F, Delmonte P, Jaworska K, Dugo P, Mondello L, Rader JI: **Employing ultra high pressure liquid chromatography as the second dimension in a comprehensive two-dimensional system for analysis of Stevia rebaudiana extracts.** *J Chromatogr A* 2011, **1218**:2012-2018.
 39. Bassanese DN, Holland BJ, Conlan XA, Francis PS, Barnett NW, Stevenson PG: **Protocols for finding the most orthogonal dimensions for two-dimensional high performance liquid chromatography.** *Talanta* 2015, **134**:402-408.
- A paper outlining a systematic method to select a pair of HPLC columns that provide the most orthogonal separations for a given sample. The procedure is simple to follow and explanations are given as to what parameters have to be considered and why. The authors outline the protocol to follow, giving a real life example using a range of compounds. This paper would be useful for anyone who is unsure about how set out an experiment to determine the optimum column combination for their 2D-HPLC analysis.
40. Bertsch W: **Two-dimensional gas chromatography. concepts, instrumentation, and applications — part 2: comprehensive two-dimensional gas chromatography.** *J High Resolut Chromatogr* 2000, **23**:167-181.
 41. Koek MM, Muilwijk B, van Stee LLP, Hankemeier T: **Higher mass loadability in comprehensive two-dimensional gas chromatography-mass spectrometry for improved analytical performance in metabolomics analysis.** *J Chromatogr A* 2008, **1186**:420-429.
 42. Kouremenos KA, Pitt J, Marriott PJ: **Metabolic profiling of infant urine using comprehensive two-dimensional gas chromatography: application to the diagnosis of organic acidurias and biomarker discovery.** *J Chromatogr A* 2010, **1217**:104-111.
 43. Phillips M, Cataneo RN, Chaturvedi A, Kaplan PD, Libardoni M, Mundada M, Patel U, Zhang X: **Detection of an extended human volatome with comprehensive two-dimensional gas chromatography time-of-flight mass spectrometry.** *PLoS ONE* 2013, **8**:1-8.
 44. Beckstrom AC, Tanya P, Humston EM, Snyder LR, Synovec RE, Juul SE: **The perinatal transition of the circulating metabolome in a nonhuman primate.** *Pediatr Res* 2012, **71**:338-344.
 45. Nicolotti L, Cordero C, Bressanello D, Cagliero C, Liberto E, Magagna F, Rubiolo P, Sgorbini B, Bicchi C: **Parallel dual secondary column-dual detection: a further way of enhancing the informative potential of two-dimensional comprehensive gas chromatography.** *J Chromatogr A* 2014, **1360**:264-274.
 46. Lesellier E, West C: **The many faces of packed column supercritical fluid chromatography — a critical review.** *J Chromatogr A* 2015, **1382**:2-46.

A review introducing the concept and practicalities of supercritical fluid chromatography (SFC). The authors discuss the main features of SFC, with a focus on achiral separations. The review is not extensive but provides expert opinion on the characteristics of the method, including the advantages and disadvantages faced when using SFC. The review covers the physical properties of SFC, the physio-chemical properties of different mobile phase compositions, the different stationary phases available, column selection and the devices required for SFC analysis. Some of the highlights include SFC method development, the hyphenation of SFC in 2D separation systems and examples of the application of SFC to various studies.

47. West C, Lemasson E, Bertin S, Hennig P, Lesellier E: **An improved classification of stationary phases for ultra-high performance supercritical fluid chromatography.** *J Chromatogr A* 2016, **1440**:212-228.
48. Stevenson PG, Tarafder A, Guiochon G: **Comprehensive two-dimensional chromatography with coupling of reversed phase high performance liquid chromatography and supercritical fluid chromatography.** *J Chromatogr A* 2012, **1220**:175-178.
49. Guibal P, Thiébaud D, Sassié P, Vial J: **Feasibility of neat carbon dioxide packed column comprehensive two dimensional supercritical fluid chromatography.** *J Chromatogr A* 2012, **1255**:252-258.
50. Berger TA, Berger BK: **Separation of 9 sulfonamide drugs in \approx 4 min by ultra-high performance supercritical fluid chromatography (UHPSFC): with a feasibility study for detection in milk.** *Chromatographia* 2013, **76**:1631-1639.
51. Zhou Q, Gao B, Zhang X, Xu Y, Shi H, Yu L: **Chemical profiling of triacylglycerols and diacylglycerols in cow milk fat by ultra-performance convergence chromatography combined with a quadrupole time-of-flight mass spectrometry.** *Food Chem* 2014, **143**:199-204.
52. Beelders T, Kalili KM, Joubert E, De Beer D, De Villiers A: **Comprehensive two-dimensional liquid chromatographic analysis of rooibos (*Aspalathus linearis*) phenolics.** *J Sep Sci* 2012, **35**:1808-1820.
53. Cacciola F, Donato P, Giuffrida D, Torre G, Dugo P, Mondello L: **Ultra high pressure in the second dimension of a comprehensive two-dimensional liquid chromatographic system for carotenoid separation in red chili peppers.** *J Chromatogr A* 2012, **1255**:244-251.
54. Le Masle A, Angot D, Gouin C, D'Attoma A, Ponthus J, Quignard A, Heinisch S: **Development of on-line comprehensive two-dimensional liquid chromatography method for the separation of biomass compounds.** *J Chromatogr A* 2014, **1340**:90-98.
55. Li Z, Chen K, Guo M, Tang D: **Two-dimensional liquid chromatography and its application in traditional Chinese medicine analysis and metabonomic investigation.** *J Sep Sci* 2016, **39**:21-37.