



THE UNIVERSITY *of* EDINBURGH

## Edinburgh Research Explorer

### From instrument to architecture

**Citation for published version:**

Moffitt, L 2018, 'From instrument to architecture: Environmental models as contemporary design tools', *Technology, Architecture + Design*, vol. 2, no. 2, pp. 229-239.  
<https://doi.org/10.1080/24751448.2018.1497376>

**Digital Object Identifier (DOI):**

[10.1080/24751448.2018.1497376](https://doi.org/10.1080/24751448.2018.1497376)

**Link:**

[Link to publication record in Edinburgh Research Explorer](#)

**Document Version:**

Peer reviewed version

**Published In:**

Technology, Architecture + Design

**Publisher Rights Statement:**

This is an Accepted Manuscript of an article published by Taylor & Francis in Technology, Architecture + Design on 29 November 2018, available online: <https://www.tandfonline.com/doi/abs/10.1080/24751448.2018.1497376>

**General rights**

Copyright for the publications made accessible via the Edinburgh Research Explorer is retained by the author(s) and / or other copyright owners and it is a condition of accessing these publications that users recognise and abide by the legal requirements associated with these rights.

**Take down policy**

The University of Edinburgh has made every reasonable effort to ensure that Edinburgh Research Explorer content complies with UK legislation. If you believe that the public display of this file breaches copyright please contact [openaccess@ed.ac.uk](mailto:openaccess@ed.ac.uk) providing details, and we will remove access to the work immediately and investigate your claim.





THE UNIVERSITY *of* EDINBURGH

## Edinburgh Research Explorer

### From Instrument to Architecture

**Citation for published version:**

Moffitt, L 2018, 'From Instrument to Architecture: Environmental Models as Contemporary Design Tools' Technology, Architecture + Design, vol. 2, no. 2, pp. 229-239. DOI: 10.1080/24751448.2018.1497376

**Digital Object Identifier (DOI):**

[10.1080/24751448.2018.1497376](https://doi.org/10.1080/24751448.2018.1497376)

**Link:**

[Link to publication record in Edinburgh Research Explorer](#)

**Document Version:**

Peer reviewed version

**Published In:**

Technology, Architecture + Design

**Publisher Rights Statement:**

This is an Accepted Manuscript of an article published by Taylor & Francis in Technology, Architecture + Design on 29 November 2018, available online: <https://www.tandfonline.com/doi/abs/10.1080/24751448.2018.1497376>

**General rights**

Copyright for the publications made accessible via the Edinburgh Research Explorer is retained by the author(s) and / or other copyright owners and it is a condition of accessing these publications that users recognise and abide by the legal requirements associated with these rights.

**Take down policy**

The University of Edinburgh has made every reasonable effort to ensure that Edinburgh Research Explorer content complies with UK legislation. If you believe that the public display of this file breaches copyright please contact [openaccess@ed.ac.uk](mailto:openaccess@ed.ac.uk) providing details, and we will remove access to the work immediately and investigate your claim.



## From Instrument to Architecture: Environmental Models as Contemporary Design Tools

**Abstract:** This paper revisits a case study in the history of building technology, Étienne-Jules Marey's 1900-1902 wind tunnel prototypes, and makes links between Marey's wind tunnel and the prototyping of environmental models as environmental design tools today. Using historiographic research and physical prototypes, the research asks: What insights about designing with airflow do Étienne-Jules Marey's wind tunnel and contemporary environmental models offer architectural designers today? Insights are explored in relation to three measures: Marey's wind tunnel photographs measure air flow rates; the wind tunnel measures air's material sensitivity; in the author's prototypes, air and water become measures of constructional defects, suggesting a tectonic approach to architecture. The significance of the research lies in situating a technique exemplified by Marey within a contemporary architectural design context.

**Keywords:** Environmental Design, History and Theory of Building Technology, Physical Models, Building Ventilation

### 1 Introduction

Architects require technical, representational, and conceptual tools to design in a way that is highly responsive to air movement. Skillful design of airflow can lead to effective ventilation strategies, to enhanced exterior microclimates, to reduced building air infiltration, to reduced urban wind tunneling and downward vortex effects--all of which can reduce energy consumption and/or increase thermal comfort. Increased disciplinary specialization, the complexity of fluid

dynamics, and representational limitations, however, present current obstacles to this agenda. Hight clarifies what is at stake: “The architect’s ability to manipulate environmental conditions has been limited by the discipline’s tools themselves, which require either cumbersome technical simulations of fluid dynamics or notational rules of thumb...To engage such processes requires expanding our mindset and toolkit to make knowable such nonvisual phenomena objects” (2009, 26). Representing environmental phenomena is crucial to being able to engage with them as design variables. As Hight notes, however, architects have struggled to represent such environmental conditions due to their thermodynamic and fluid dynamic complexity. Drawn environmental sections and computational fluid dynamics (cfD) are two representational conventions used by designers to represent airflow and thermal exchange. This paper explores a third strategy—using physical environmental models—for making ‘knowable’ the ‘nonvisual phenomena object’ of airflow. This research revisits a historical model that measured environmental flows to inform new ways of working with air and water as material conditions and suggests a methodology in which these material conditions inform the design of architecture as an environmental instrument.

In this paper, the term ‘environmental model’ refers to a physical instrument consisting of a controlled environment that materialises the phenomena of airflow in relation to a scaled architectural model. Environmental models have conventionally been used as quantitative engineering tools for establishing force-similitude and reconciling scale effects. “If scaled correctly, deflections, deformation, speeds, forces, accelerations, energies, temperatures, electric currents, magnetic fields, and a host of other relevant quantities measure on the scale model permit prediction of the corresponding quantities of the prototype design” (Emori and Schuring 1977, 7). The qualitative value of environmental models in engineering is generally downplayed.

In *Scale Models in Engineering: Fundamentals and Application*, Emori and Schuring dismiss qualitative models as being beyond the scope of the book despite their valuable role in “delineating the boundaries of new engineering devices rather than in pinpointing exact data” (ibid, 5). Similarly, Pope’s comprehensive *Low-speed Wind Tunnel Testing* devotes only two (of 728) pages to qualitative ‘Small Wind Tunnels’. While qualitative structural models such as Frei Otto’s tensile form-finding experiments, Antoni Gaudi’s hanging catenary studies, and Heinz Isler’s frozen cloth models are well-known, environmental models simulating airflow have received less attention. Moreover, environmental models tend to be used as final design verification tools in engineering. Munitxa notes methodological limitations of the conventional use of cfd and wind tunnels, which are “often unable to follow the rapidity of the design changes and decision making” (Munitxa 2015, 366).

Environmental models played a limited role as architectural design tools in the post-war period. Aronin notes that in 1949, the Aeronautical Engineering Department at the University of Texas “initiated a modest program in research on the aerodynamic characteristics of modern homes... Full-scale experimental rooms as well as models of them for wind-tunnel tests, were constructed” (1963, 201). At their zenith in the 1950s and 1960s, academics such as Victor and Aladar Olgyay used environmental models to make solar trajectories and wind flow patterns visible to hone bioclimatic design methodologies. These techniques were then eclipsed by computational techniques. Contemporary ventilation resources for architects tend to focus on computational strategies, and when they do include reference to physical models, the emphasis is again on reconciling scale effects. *In Designing Spaces for Natural Ventilation: An Architect’s Guide*, Battaglia and Passe describe some advantage of using wind tunnels, but lament that, “The drawback is that the dynamics of the air flow within the building is not measured” (2015, 281).

There are some contemporary designers using physical models, often with digital components, for designing within a range of environmental processes. Landscape architects such as Cantrell and Holzman (2016), Robinson (2014), and Rico and Llabres Valls (2016) have integrated digital sensors into physical models to track hydrological and geomorphological processes, which are then often augmented or tested further through digital simulation. Munitxa has integrated robotics with wind tunnels to test how building form and materiality impact airflow (2015). Moreover, architectural designers such as Smout Allen and Geoff Manaugh have designed ‘envirographic’ instruments for registering contingent environmental conditions at full-scale (Manaugh 2013). This study presents a design methodology for prototyping scaled controlled environments of airflow and reflects on how the design and construction of these prototypes offers design insights about the interactions between fluid and solid materials. A look first to an early wind tunnel prototype introduces some key design considerations about working materially with air that informed contemporary prototypes.

### Phenomenon

Étienne-Jules Marey was an experimental physiologist practicing from mid to late nineteenth century in France at a time when precision measure and working in the controlled environment of the laboratory were increasing hallmarks of the sciences (Braun 1992). Marey exemplified the empirical tradition of relying on the senses for verifiable data about the workings of the physical world (Daston and Galison 2010). The subject of Marey’s focus was animate motion; he had a particular interest in the mechanics underpinning flight. Marey’s earliest work involved devising drawing instruments that made physiological conditions such as blood flow intensities and heart rates visible as a series of lines and curves transcribed on a surface. The

technique by which these transcriptions were translated from machine to drawing is referred to as the graphic method. The graphic method was used to translate a vast range of human and animal motion throughout Marey's career, but the defining features were the same: a transcribing device distilled three-dimensional movement over time into two-dimensional legible/measurable lines on a flat surface (Figure 1). Marey was also a pioneer of many photographic techniques, particularly chronophotography. One of the most well-known photographic instruments he devised, the photographic gun, captured successive movements of a bird's wing movements in flight (Figure 2). Using the graphic method and chronophotography, Marey's life's work entailed designing sensitive instruments for making invisible phenomena visible and, in so doing, measurable. While Marey neither invented the wind tunnel nor the smoke visualisation technique, his flow visualisation techniques were the most legible at the time as they grew

directly from the extensive repertoire of visual translation techniques that preceded them.

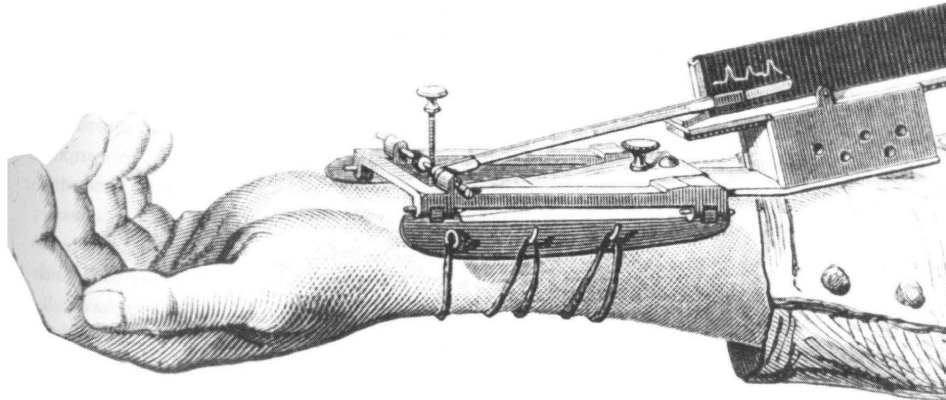

Figure 1. Étienne-Jules Marey's first instrument, the 'pulse-writer', is an early example of the graphic method, translating the invisible pressure of blood flow to continuous high-contrast lines on paper. Credit: Marey 1860. Source: Braun 1992, 17.

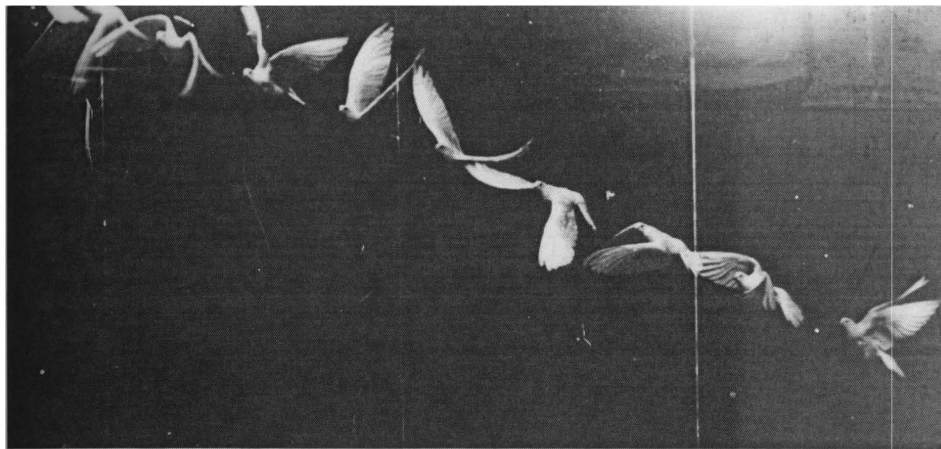

Figure 2. One of the most well-known photographic instruments Marey devised, the photographic gun, captured successive movements of a bird's wing movements in flight. The chronophotographic technique makes visible the incremental movement of bird wings in flight, a function of air resistance and uplift. Credit: Marey 1888. Source: Braun 1992, 141.

Marey's wind tunnels were one of the final projects of his prolific career and marked a shift from focusing on the subject of movement to the medium through which movement takes place. Marey completed a series of water tank studies that are the most direct visual precursors to his wind tunnel studies. The conceptual leap between working with water and working with air was an important one for it established "the all-important equivalence of water and air as elastic mediums--an observation that would lead people the likes of Marey to realize that testing bodies in water and air were not mutually exclusive" (Ramirez 2013 p189).



In the wind tunnel, smoke from burning tinder was drawn through fine silk gauze, which straightened air currents before they progressed into a viewing chamber, lined on three sides with black velvet. Air was drawn through the chamber using an aspirating ventilator. Marey describes the seemingly straightforward concept behind the wind tunnel as follows: "Produce a steady stream of air within a closed device with transparent walls; introduce parallel and equidistant wisps of smoke; on the trajectory of these wisps of smoke, place diversely shaped surfaces, at the contact of which they change their course; light brightly and take an instant photograph of their appearance. Such was the programme" (quoted in Musee D'Orsay 2005) (Figure 3). Like the graphic method, the high contrast smoke filament cords create continuous lines moving through space; the darkened wind tunnel is spatially compressed, creating a flat substrate for registering this movement. Flow patterns are captured through temporally calibrated photographs that reveal a moment in time of a particular flow regime (Figure 4).

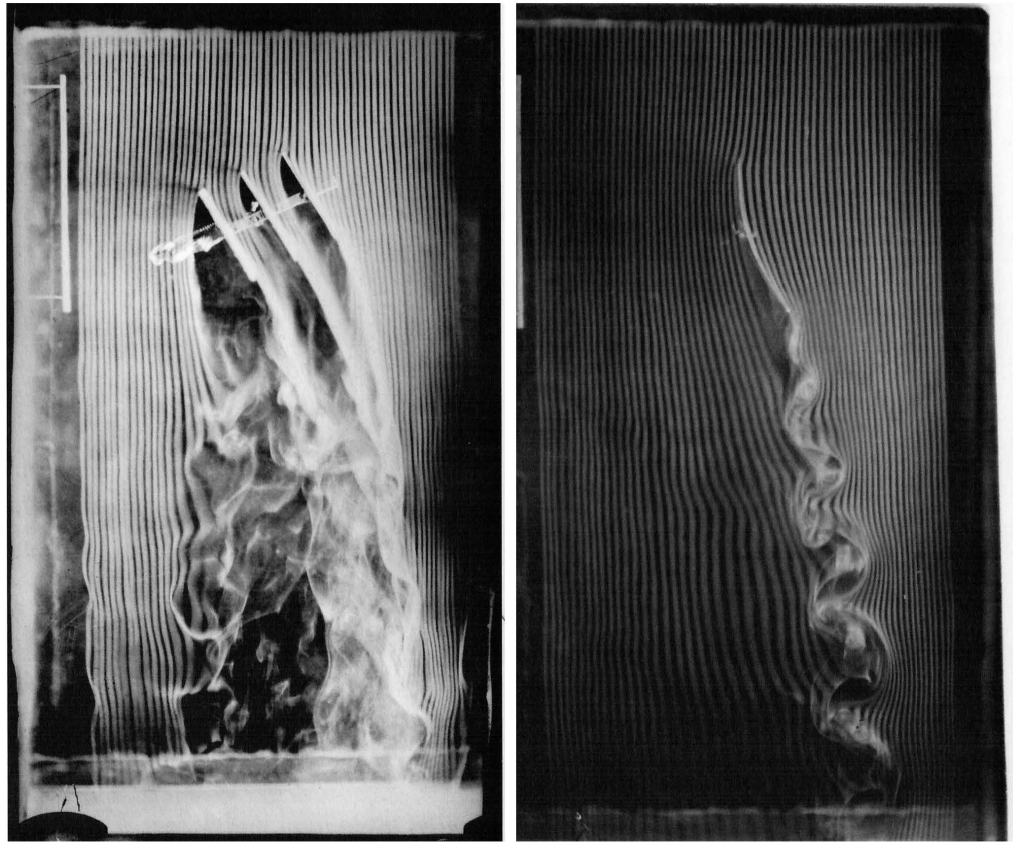

Figure 3. While Marey was not the pioneer of the smoke-stream wind tunnel technique, his technique was highly legible, translating the vast three-dimensional matrix of air movement to a highly legible series of air lines moving through time. On the leeward side of models, vortex trails indicate turbulence. Credit: Marey 1902. Source: Huberman 2004, 148, 130.

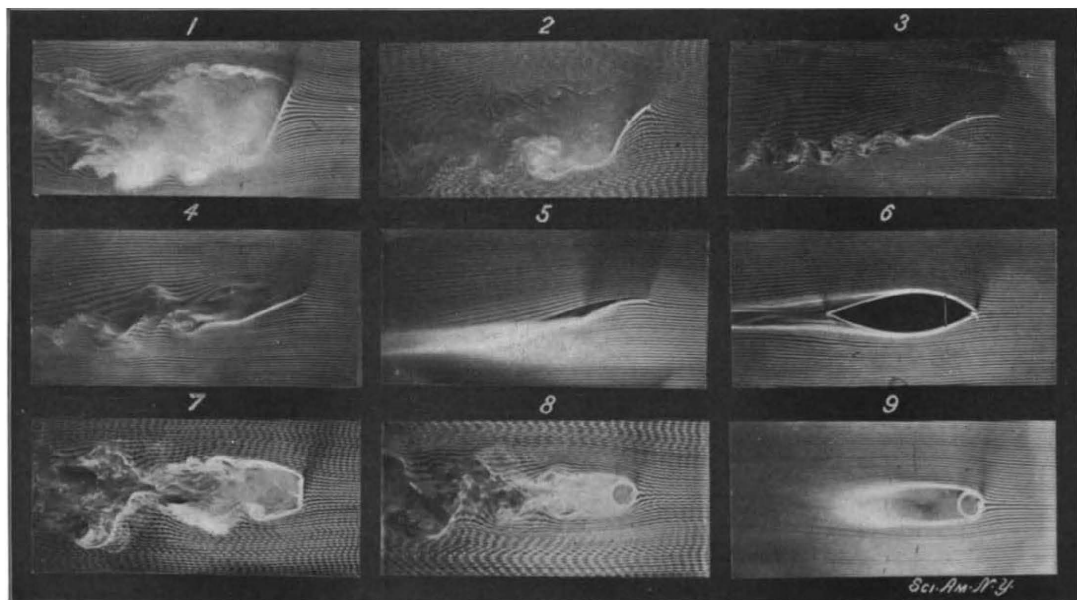

Figure 4. Marey's photographs of the wind tunnel highlight three variables: how the shape and orientation of an obstacle impacts airflow, photographic settings for best capturing turbulence, and techniques for measuring air speed using a vibrating device that translates lines of air to waves. Credit: Marey 1902. Source: Scientific American 1902.

The primary contribution of Marey's wind tunnel at the time was the technique he devised for measuring air speed differentials. "M. Marey has devised an ingenious method of measuring the speed of each stream at different points of its path, and especially in front and in the rear of the obstacle where adjustments to the currents would be most pronounced and would have most impact on aerodynamic performance" (Scientific American 1902, 75). He did this by incorporating a vibrating device that translated linear smoke streams into waveforms, the crests of which could be counted and their rates of movement understood relationally (Figure 5).

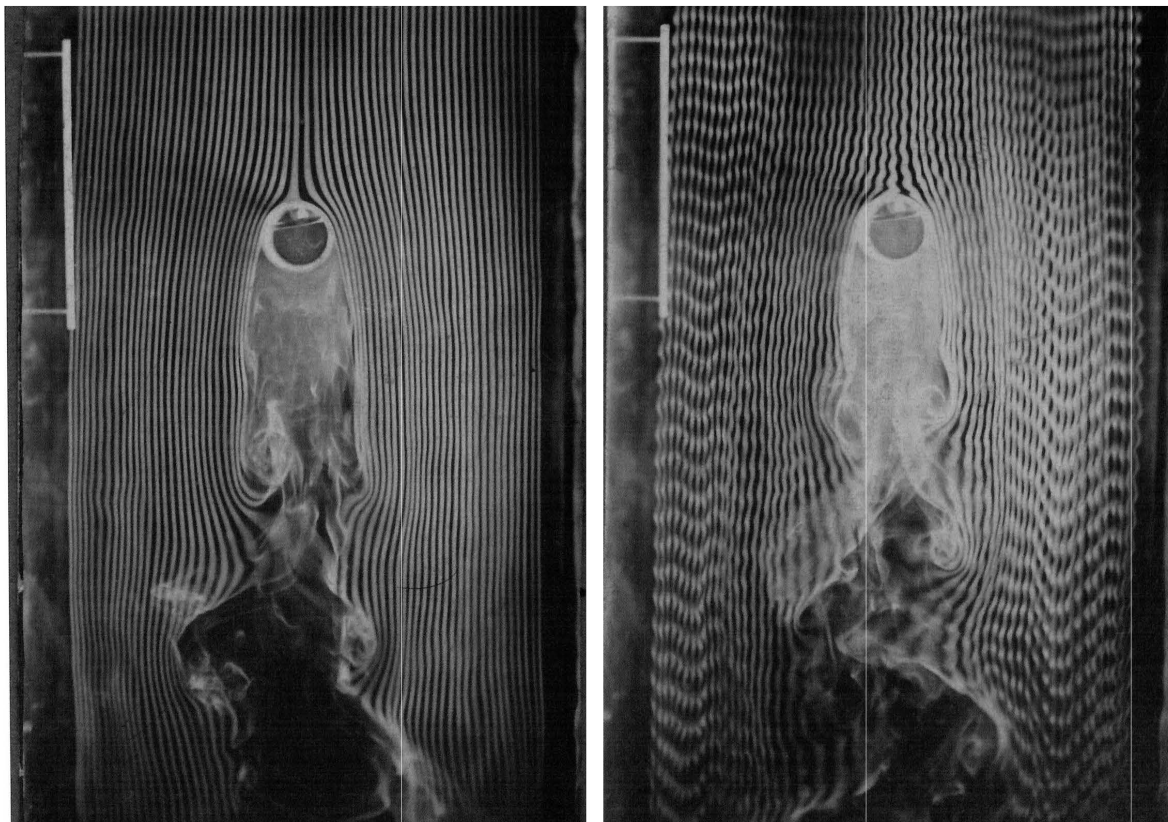

Figure 5. Marey devised a technique for measuring air speed. A vibrating device translates lines of air to ten waves per second. A ruler inside the box facilitates measuring distance each wave travels over the tenth of a second. Credit: Marey 1902. Source: Huberman, 152, 153.

Funded by the Smithsonian Institute, Marey's wind tunnels were developed as aeronautics research tools. However, despite the visual clarity of his photographs and the air flow rate measuring technique, the wind tunnels contributed little to the emerging field of aeronautics;

they merely corroborated existing knowledge about wing profiles (Scientific American 1902). The crucial deficiency of Marey's wind tunnels at the time was that they could not provide numeric data on air pressure, a crucial parameter for understanding air resistance (Hoffman 2013). Thus, while Marey's photographs made measurable one phenomena--air speed--they neglected to capture another deemed more useful at the time--air pressure.

The significance of Marey's wind tunnel technique for architectural designers lies less in what is being measured or not measured than in what was required to make air measurable in the first place. Marey's photographs offer a highly legible view of how air behaves as a moving material condition, as a series of lines moving over time. Making these lines visible entailed substantial conceptual spatial and material translation. Air was transformed from an invisible vast hemispheric matrix to a legible, high-contrast phenomena legible in relation to the human body. Marey compressed and materialised air through the introduction of a new material, smoke, which retained fluidity while allowing visibility. It is only through these translations that air could be made into a visible, measurable artefact. By making air visible, its steady state and turbulent behaviours become legible as either moving lines white cords or whirling swirls and vortex trails of turbulence when their path is disturbed. Marey spatially compressed and materialised air, allowing it to play a more active role as a design material.

### Instrument

The final wind tunnel featured in *Scientific American* and further described by Braun (2013) consisted of 152cm (5') x 61 cm (2') chamber, a 90cm (3') section of which was lined on three sides with glass and with black velvet on the fourth. Smoke produced by burning tinder was fed into the upper air chamber and drawn into the glass chamber through sixty 6mm ( $\frac{1}{4}$ "

diameter tubes distanced 6mm (1/4") apart. The smoke was drawn through fine silk gauze with equal warp and weft, which straightened the air currents before they were let into the chamber via an aspirating ventilator that drew air to the other end of the chamber (Figure 6). If we move the lens of the camera back from the testing chamber to capture the componentry and assembly of wind tunnel, what other insights are revealed about designing with airflow?

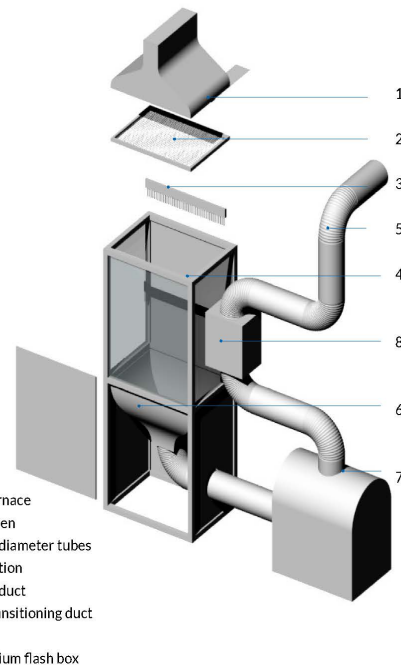
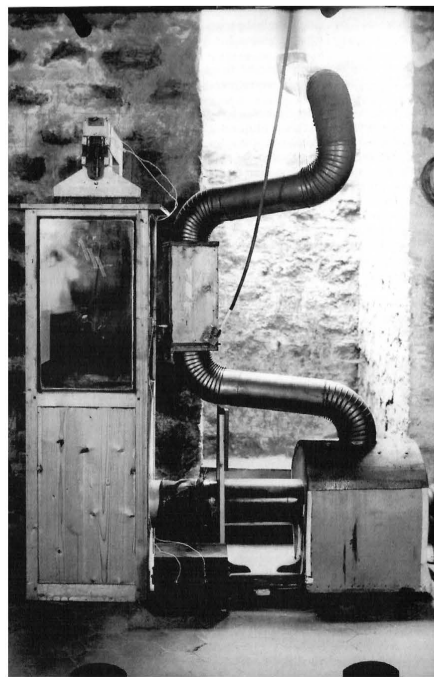

Figure 6. Étienne-Jules Marey's final wind tunnel prototype appears an assemblage of wooden boxes and flexible ducts. It is, however, better to understand it as a sensitive environmental instrument. (left) Credit: Marey 1902. Source: Huberman 2004, 110. (left) Credit: Author and Qingqing Zhang.

When viewing photographs of the wind tunnel, one is first struck by an incongruance between the robust assembly of wooden boxes and flexible ducts, and the delicate wisps of curling smoke that it creates. To fully appreciate the complexity of Marey's wind tunnel requires understanding it not as an awkward mechanical assemblage but as a sensitive precision instrument. The pursuit of plotting forces and pressure differentials were the bookends of Marey's career and Marey was aware of the delicate nature of working with the forces of air;

slight frictions and resultant inertia in the mechanics of graphic method transcriptions often resulted in distortions in the resultant curves (Hinterwalder 2015).

As with his other instruments, Marey's wind tunnel was sensitive to external disruption. "When the ventilator is set in motion the air is aspirated and draws with it the smoke, and the latter descends in a series of vertical cords which may reach as long as three feet if the air of the room is perfectly still. This is not always easy to realize as often the movements of the operator are sufficient to cause a perceptible deflection of the air-currents" (Scientific American 1902, 75). So sensitive was Marey's wind tunnel that even the slightest pressure differential beyond the controlled environment testing bed would disrupt this steady-state condition. Marey's wind tunnel registers the unintentional blips caused by external disruptions as deviations in the steady smoke streams (Figure 7). The 'transcribing device' that transferred external disruption into the interior testing bed was air in the form of vibrations transferred through the base of the wind tunnel.

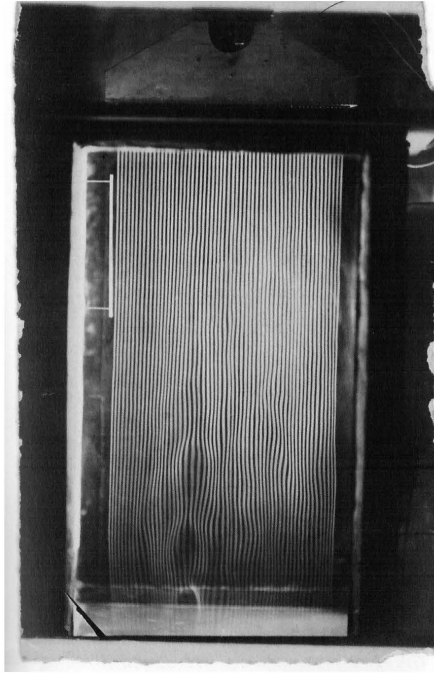

Figure 7. Most photographs of Marey's wind tunnel occlude the complexity of creating the steady state condition reflected in continuous moving lines. In reality, Marey's wind tunnel was extremely sensitive to both internal and external disruption. Credit: Marey, 1902. Source: Huberman 2004, 111.

Wind tunnels are conventionally used to measure air flow rates or pressures. However, other lessons about airflow are revealed through a close look at the componentry and workings of Marey's wind tunnel. Wind tunnels contain physical components that actively manipulate airflow, revealing that air can be generated, straightened, settled, directed, and outlet through the shape and form of its enclosures. Marey's wind tunnel also reveals that air is highly sensitive to both internal and external disruption, transferring disturbance through solid materials. In even the most controlled settings, there are exchanges between interior and exterior environments. Wind tunnels simulate exterior conditions within a controlled interior testing chamber contained within a controlled 'laboratory' interior, acting as complex environmental mediating devices between nested interior and exterior environments (Ramirez 2013).

## Instrumentation: Wind Tunnels

Photographic documentation of the wind tunnel occlude the full complexity of what is entailed in constructing the steady-state conditions that enables smoke cords to follow a steady path. This section introduces a third vantage point: the development of contemporary wind tunnel and water table prototypes inspired by Marey's that explore further insights about designing with airflow revealed by working directly with air as a material condition.

There are two physical modelling techniques that make airflow associated with pressure differentials visible and/or measurable: wind tunnels and water tables. While the range of sizes and assemblies of wind tunnels is diverse, the componentry for small-scale open circuit wind tunnels is roughly the same. A contraction cone speeds air by compressing it from a larger to a smaller volume before it moves through a flow straightener into the controlled environment of the test section. A diffuser connects the testing section to the air-source, generally a fan, which draws air through the tunnel (Barlow et al 1999) (Figure 8). One key design consideration informing prototype development is the need to create a continuous interior surface with smooth transition between components; unintentional projections create turbulence, disrupting the steady state condition necessary within the test section.

Guidance for constructing small-scale, open-circuit wind tunnels falls into two categories: internet resources targeting hobbyists using off-the shelf materials and an ad-hoc DIY assembly sensibility and engineering resources relying on more robust techniques, primarily using steel frames and formed sheet metal, than is necessary for small-scale qualitative architectural design exercises. In both cases, guidance focuses on performance of components (what they do) rather than on the logics, or tectonics, of construction. The prototyping process of contemporary environmental models merges insights from both domains, adopting scale and



simplicity offered by DIY resources with material precision offered by engineering resources.

As such, the prototyping process honed to a tectonic sensibility by working directly with fluid phenomena and the solid materials that contain, direct and disperse those phenomena.

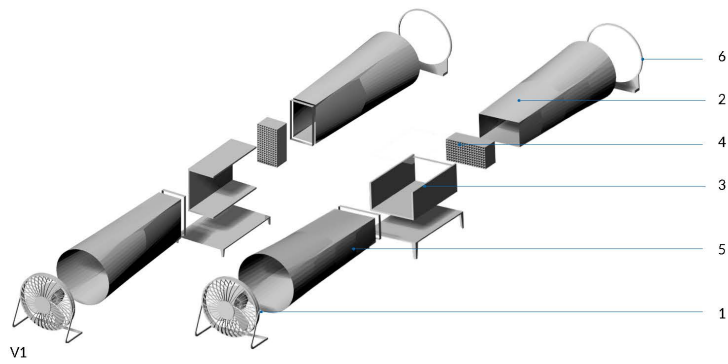

V1

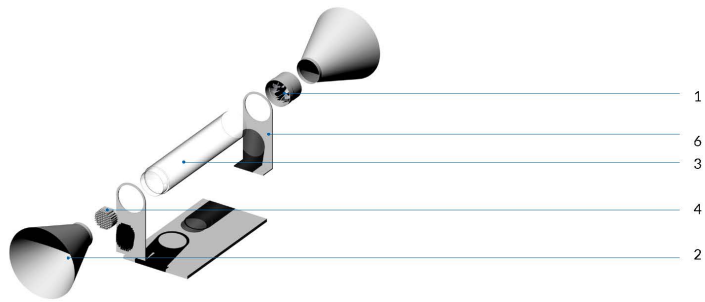

V2

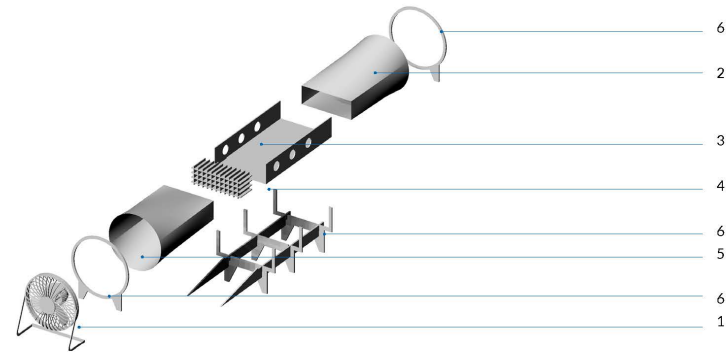

V3

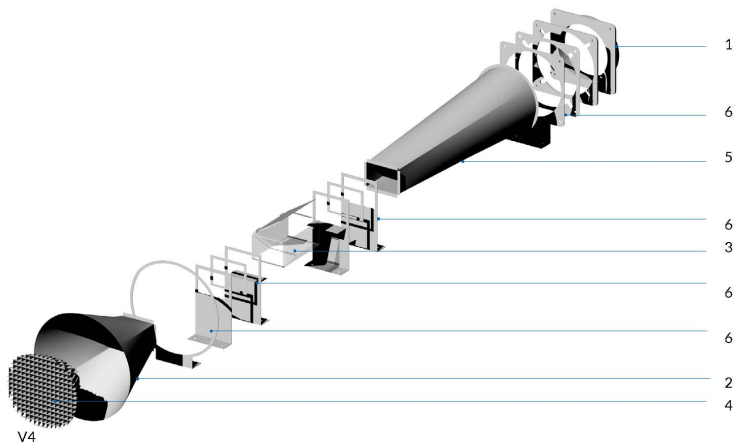

V4

- 1 Fan (Drawing Air)
- 2 Contraction Cone
- 3 Test Section
- 4 Flow Straightener
- 5 Diffuser
- 6 Support Frame

Figure 8. Wind tunnels create a controlled environment of continuous straight airflow in order to observe air movement patterns around solid objects. While the range of sizes and assemblies of wind tunnels is diverse, the componentry for all small-scale open circuit wind tunnels is roughly the same. Drawings: Author and Emma Bennett.

The first prototype V1 was constructed in a size similar to that of Marey's wind tunnel. It was designed using 2d annotated construction drawings, which provided a template for construction using sheet materials such as plywood, foam core, and plexiglass (Figure 9). Translating the ideal of the drawing into a material artefact presented challenges. Material deflections, gaps, and difficult translations between curvilinear and rectilinear components compromised precision of component fit. The suction of airflow destabilised the lightweight cardstock expansion and contraction cones, making them unwieldy to assemble and use while also revealing the force potential and destabilising effects of flowing air.

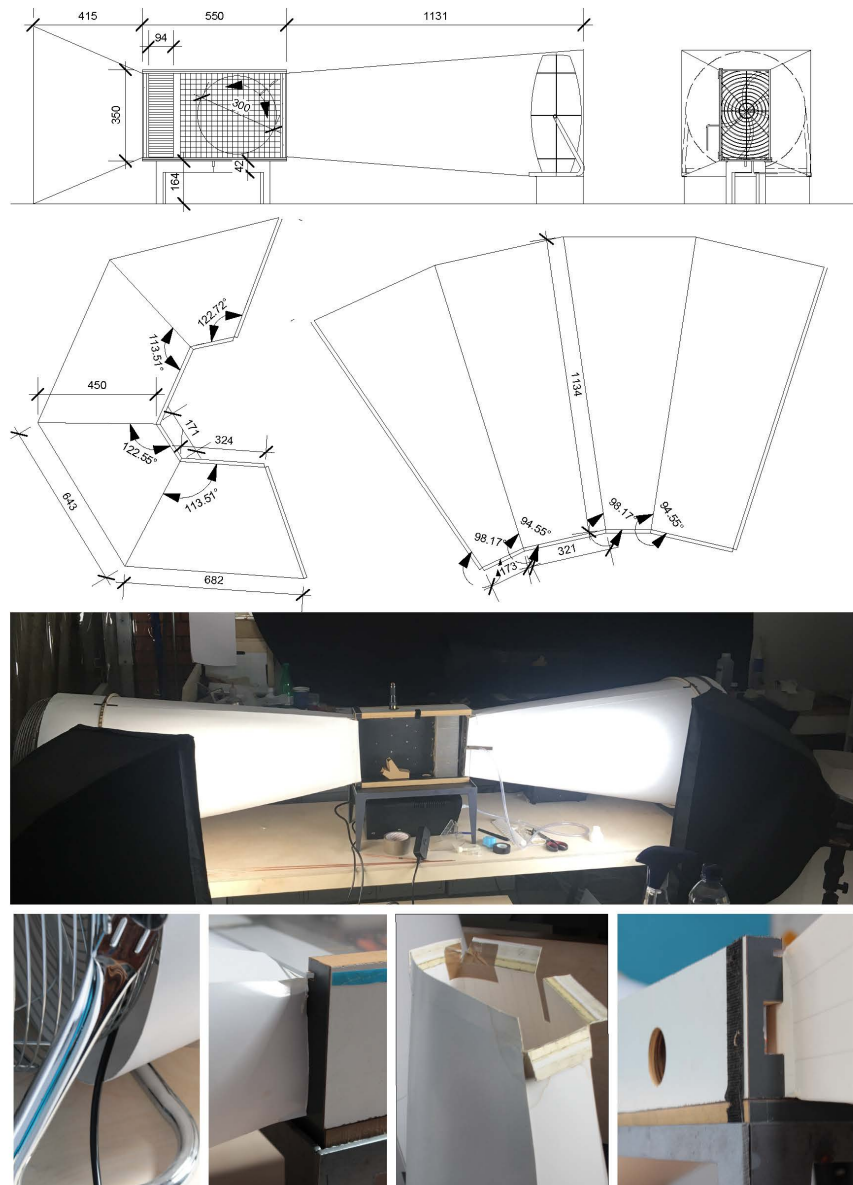

Figure 9. (top and middle) Wind tunnel V1 relied on construction drawings loosely based on the sizes and materials of Marey's wind tunnel as the starting point for construction. (bottom) Loose construction tolerances, material gaps, and awkward geometric translations from circular to rectilinear forms required refinement. Drawings and Images: Author.

To gain precision and stability, the second prototype V2 was designed first as a digital model. Components such as air straightening baffles, smoke machine nozzles, and expansion hoods designed to direct, control, or straighten air movement were digitally fabricated rather than by using hand tools. The cylindrical testing bed facilitated smoother transitions between the conical openings of expansion cones and diffusers and the testing chamber, equalising

distribution of air pressure along all surfaces (Figure 10).



Figure 10. (top) Wind tunnel V2 was developed as a digital model. (middle) A cylindrical testing section and digitally fabricated elements facilitate smooth transitions between components. (bottom) The resultant model reconciles the need to create an interior environment minimizing turbulence with an exterior form of smooth transitions and tight tolerances. Drawing and Images: Author.

Smokestream visualisation in V1 and V2 lacked the contrast evident in Marey's photographs. Workshop provision prevented working with smoke and the closest equivalent, vapour produced by smoke machines, lacked the same material density and resultant visual

clarity. Instead, a series of cardstock 'flags' attached to pin 'posts' were installed in a grid on a base inserted into the model testing back (Figure 11). Air movement patterns around models placed within the testing bed were then registered through rotation of the flags, which proved to be sensitive to even minor variations in airflow. The flags indicate flow direction as a field of vectors rather than as lines moving over time. In areas of continuous flow, flags remained largely immobilized. In areas of turbulence, flags spun continuously.

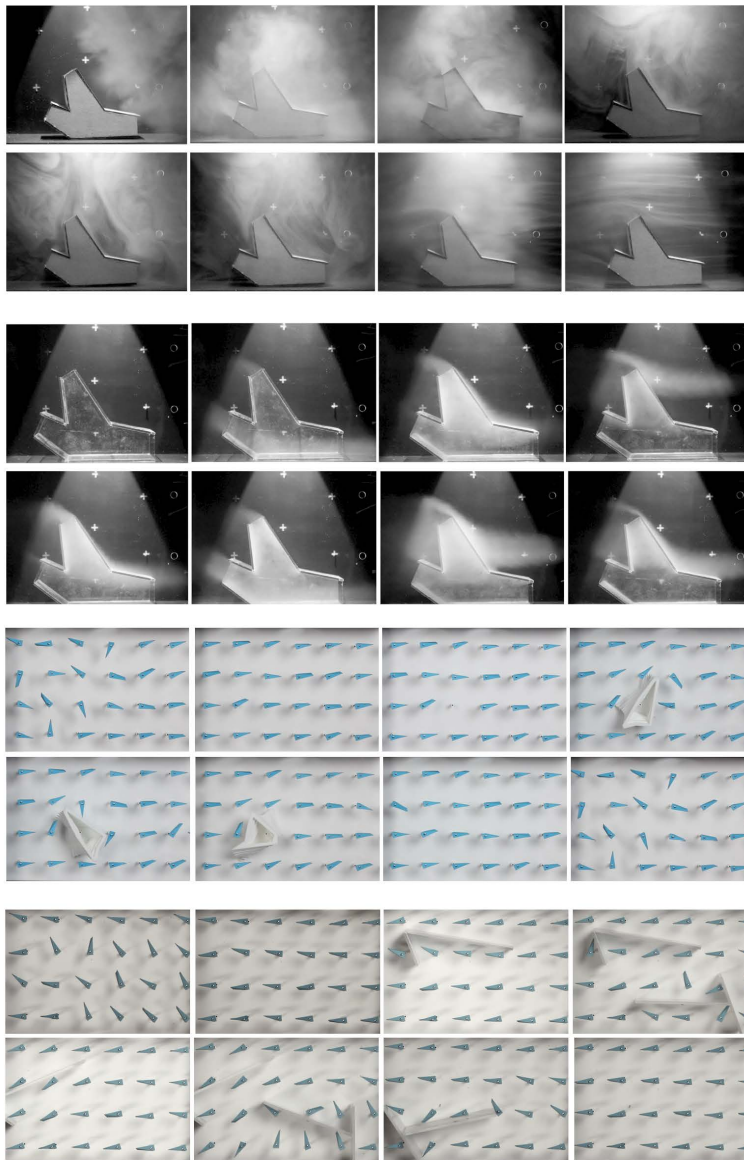

Figure 11. The first wind tunnel prototypes used vapor (from an off-the-shelf smoke machine). Initial models attempted to replicate the smoke streams of Marey's wind tunnel, but no technique yielded the striking white cords of smoke exemplified by Marey's technique. Instead, a technique using freely rotating cardstock flags enables visualisation of air movement as a vector field. Images: Author.

From here, wind tunnels prototypes followed two different trajectories: one towards diminution (V3) and the other towards increased stability (V4). V3 was scaled down to create a desktop wind tunnel. Detailing of this wind tunnel, with reduced material spans, and additional integrated supports, is proportionally more akin to an architectural assembly. Thus the test section interior can be read as a steady-state building interior rather than an exterior environment

within which an architectural model is placed. In this reading, modifications to the exterior of the testing bed test how the form and configuration of a building exterior alters flow conditions within a building interior (Figure 12). This conceptual inversion prompts thinking about environmental models as models of architecture, explored more in the next section.



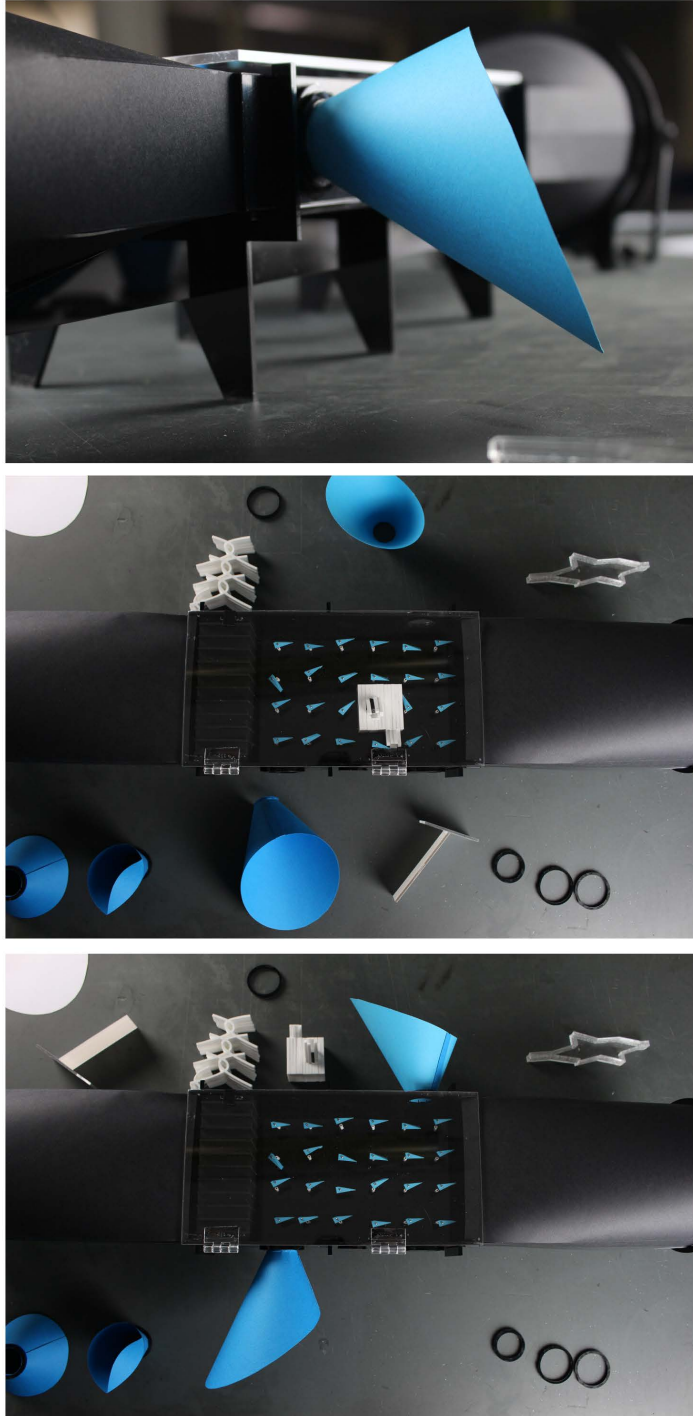

Figure 12. (top) Wind tunnel V3 was designed as a desktop wind tunnel. Its stature and proportions are more analogous to a model of architecture.(middle) Test sections generally simulates exterior flow conditions within which building models are placed. (bottom) In this prototype, the testing bed represents an interior environment. Modifications to the exterior of the testing section thus reveal exterior building componentry alters flow conditions through building interior. Drawing and Images: Author.

The final wind tunnel V4 responded to two governing tectonic parameters that evolved through the prototyping process: the need to ensure component assembly stability while also

ensuring seamless interior material transitions. A series of external steel frames provide support and facilitate seamless interior transitions between components. Neoprene layers provide a vibration buffer between steel frames (Figure 13). V1 was marked by instability and imprecise material intersections; V2 by a streamlined logic levitating within the digital environment; V4 operates somewhere in between. On the one hand, it relies to ensure smooth material and geometric transitions and equal distribution of forces. On the other hand, it responds to gravitational forces and sensitivity to exterior disturbance by ensuring stability. This assembly proved stable and easy to use while also making flow patterns visually legible.

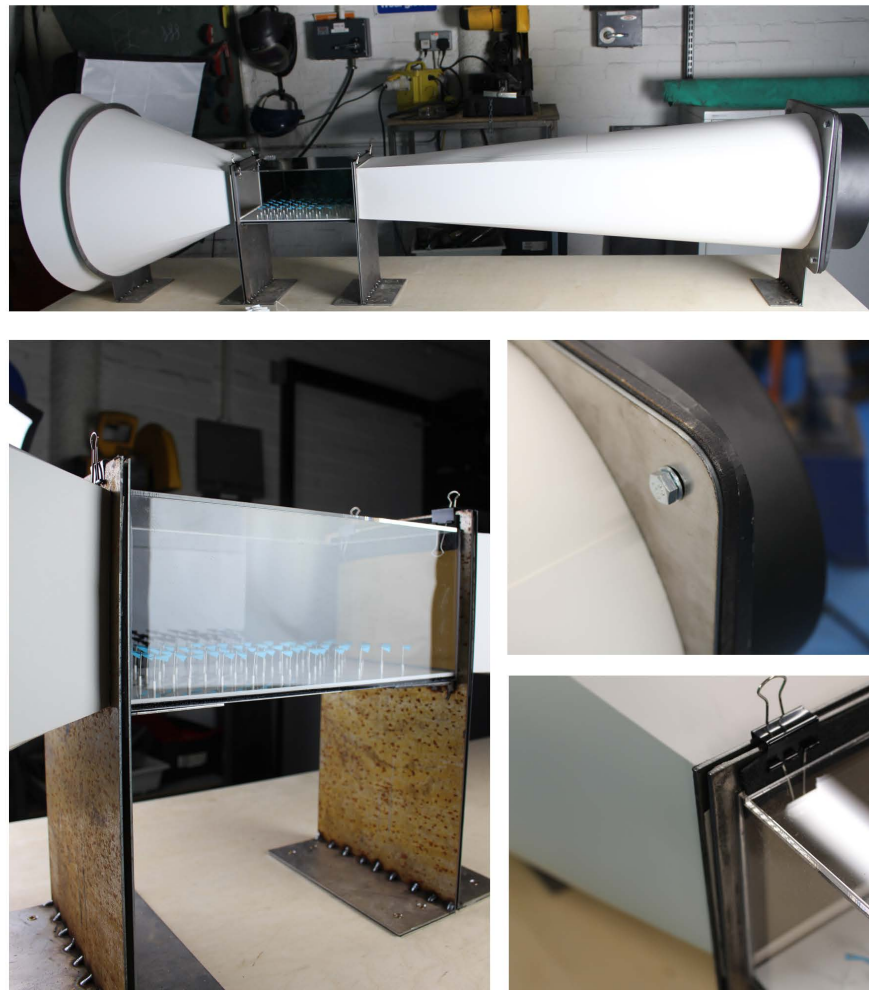
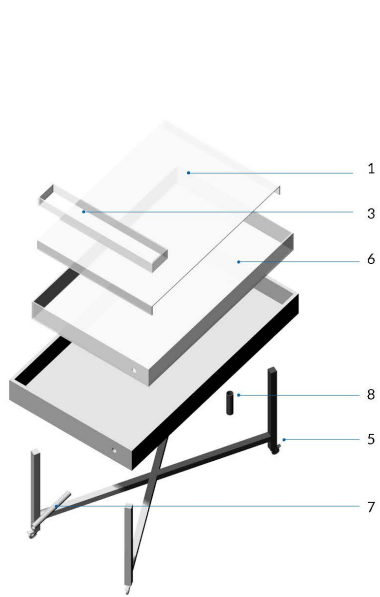

Figure 13. Wind tunnel V4 responded to two governing tectonic parameters that evolved through the prototyping process: the need to ensure component assembly stability while also ensuring seamless interior material transitions. A series of external steel frames provide support and facilitate seamless interior transitions between components. Images: Author.

## Instrumentation: Water Tables

Water tables create a steady sheet of water upon which models are placed; lines of dyed water reveal flow patterns around sectional models, revealing airflow patterns around and through buildings. Lechner's *Heating, Ventilation and Cooling* includes specifications for a water table developed at Chiang Mai University (2009, 675). The 20" x 90" (50cm x 230cm) water table sits on a raised testing surface and is composed of the following components: A trough at one end is filled with water, which then forms a steady sheet of water across the inclined testing surface before outletting through a drain at the trough in the other end (Figure 14). Once a steady flow across the table surface has been achieved, a tray with a linear array of 1 mm diameter holes is placed across the test bed. Dyed water is poured into the tray and resultant colour streams are introduced into the water. The dyed water streams then pass through and around plastic sectional models, simulating "in slow motion the smoke streams in a wind tunnel or in an actual building" (ibid). While it is tempting to focus on the swirling vortex trails in Marey's wind tunnel photographs, the water table prototyping process revealed that it was far more difficult to achieve its steady-state counterpart marked by legible, continuous filament lines (Figure 15).



V1

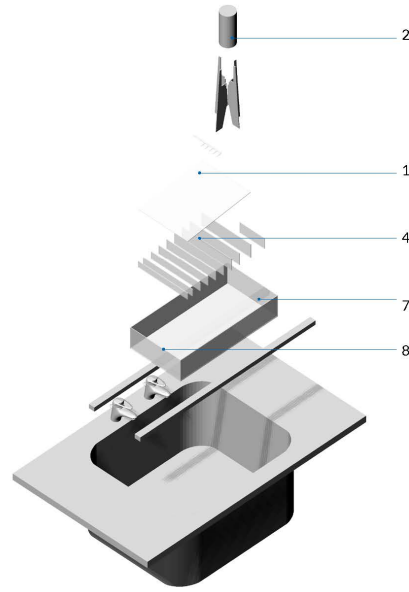

V2

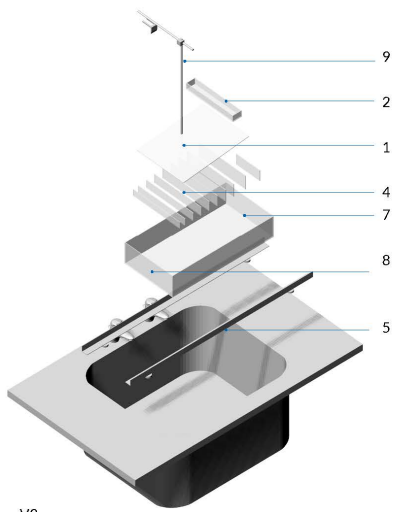

V3

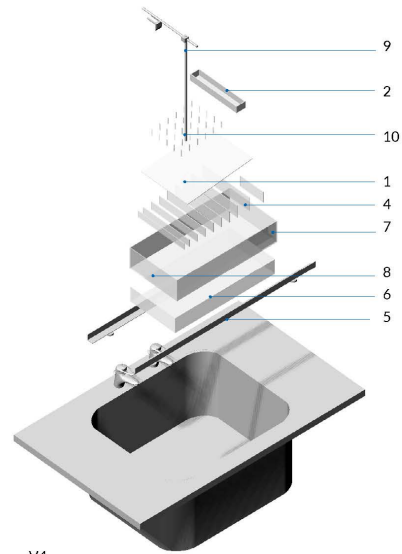

V4

- Components
- |                                |                           |
|--------------------------------|---------------------------|
| 1 Sanded Plexi Testing Surface | 6 LED Lightbox            |
| 2 Ink Reservoir                | 7 Water inlet             |
| 3 Ink Tray                     | 8 Water drain/outlet      |
| 4 Surface undercarriage        | 9 Steel Smartphone Tripod |
| 5 Support with Adjustable Feet | 10 Model Support          |

Figure 14. Just as with the wind tunnels, the first water table relied on carpentry methods of construction. Subsequent prototypes became more diminutive, relied increasingly on digital fabrication methods, and added components to facilitate fine-tuning, calibration, and photographic legibility. The fourth prototype is still in development. Drawings: Author and Emma Bennett.

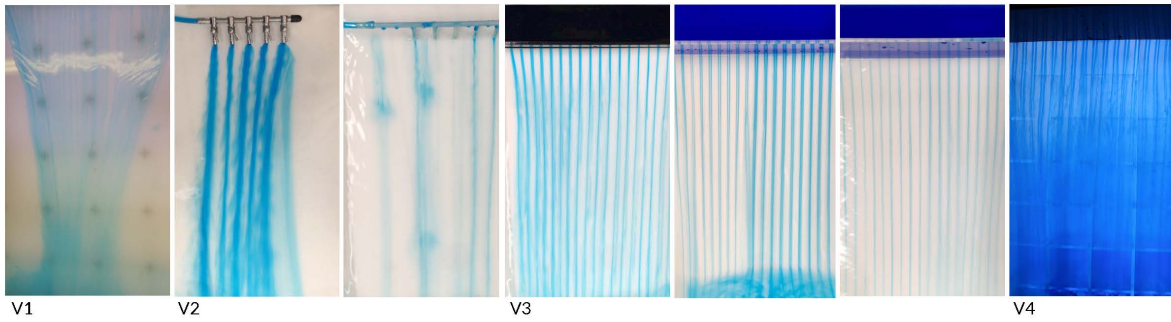

Figure 15. Water table prototyping success was measured by the degree to which a steady-state condition of even water flow was created. Dye lines register surface deflections. Various methods for dispersing dye were tested, including off the shelf aquarium splitters, 3d printed nozzles, and troughs with varying diameter holes. Images: Author.

The first water table V1 followed similar constructional strategy as the first wind tunnel, using Lechner’s prototype as a guide. In this prototype, conventional construction drawings served as a construction template and hand tools were primarily used for construction. A plywood base provides support for a plexiglass tray with water reservoir at one end, drain at the other, and testing surface in between. A plexiglass trough with a equally spaced 1mm diameter holes rests on the test surface; when filled with dyed water, filament lines disperse along the testing surface, registering flow patterns around architectural models placed on the testing bed. This prototype suffered from surface deflections that caused water to pool towards the center (Figure 16). The prototype also leaked into the plywood base. Water thus became a measure of constructional defects, pooling along deflections and leaking through gaps. In response to the weight of water, horizontal spans of sheet materials, and need for tight constructional tolerances, subsequent prototypes became more diminutive and gained precision through digitally fabricated components.

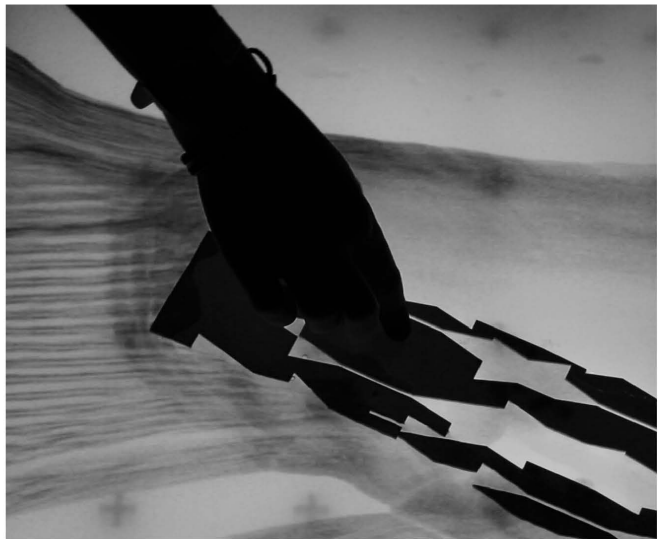

Figure 16. Water table V1 suffered from deflections and leaks, causing water to pool towards the center of the table. Images: Emma Bennett.





Figure 17. Water tables V2 and V3 were integrated with the sink, relying on gravity for drainage. Reduced surface spans and adjustable feet facilitate steady-state flow. Additional components aid in calibration. Images: Emma Bennett.

Subsequent prototypes responded increasingly to the particular forces imposed by containing and directing water (Figure 17). Whereas the first water table required a pump to redirect drained water back to the sink drain, subsequent prototypes were gravity-fed using a utility sink as water source, drain, and surface support. Prototype V2 tested a range of dye dispersal strategies using off-the-shelf aquarium splitters, 3d printed nozzles and lasercut troughs. Prototype V3 integrated componentry for surface calibration; adjustable feet establish level; a steel arm welded to the steel angle base provided steady-support for a smart phone. Prototype V4 integrated a light table

into the base. It also includes a matrix of surface supports intended to steady models susceptible to movement by water pressure (Figure 18). Water again became the measure of constructional defects, leaking through the surface testing bed and pooling into the model undercarriage below, obscuring the intended high contrast view on the top surface (Figure 19). Nevertheless, the prototyping progress reflects a tectonic logic of nested vessels and integrated mechanisms for calibration.

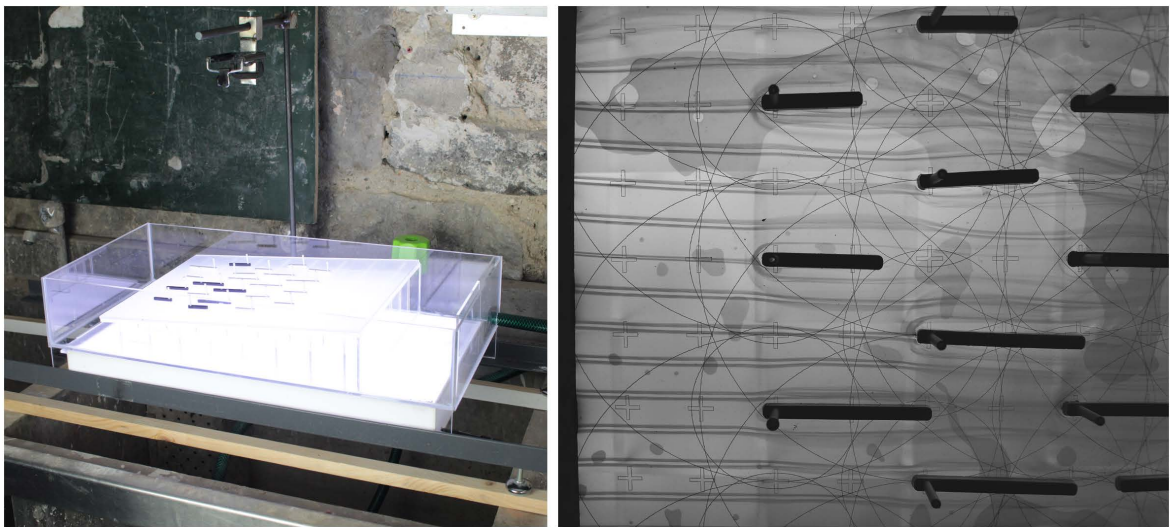

Figure 18. Water table V4 merges insights from the first and third prototypes; it integrates a lightbox, reducing photographic light reflections, as well as a system for securing models. Images: Author.



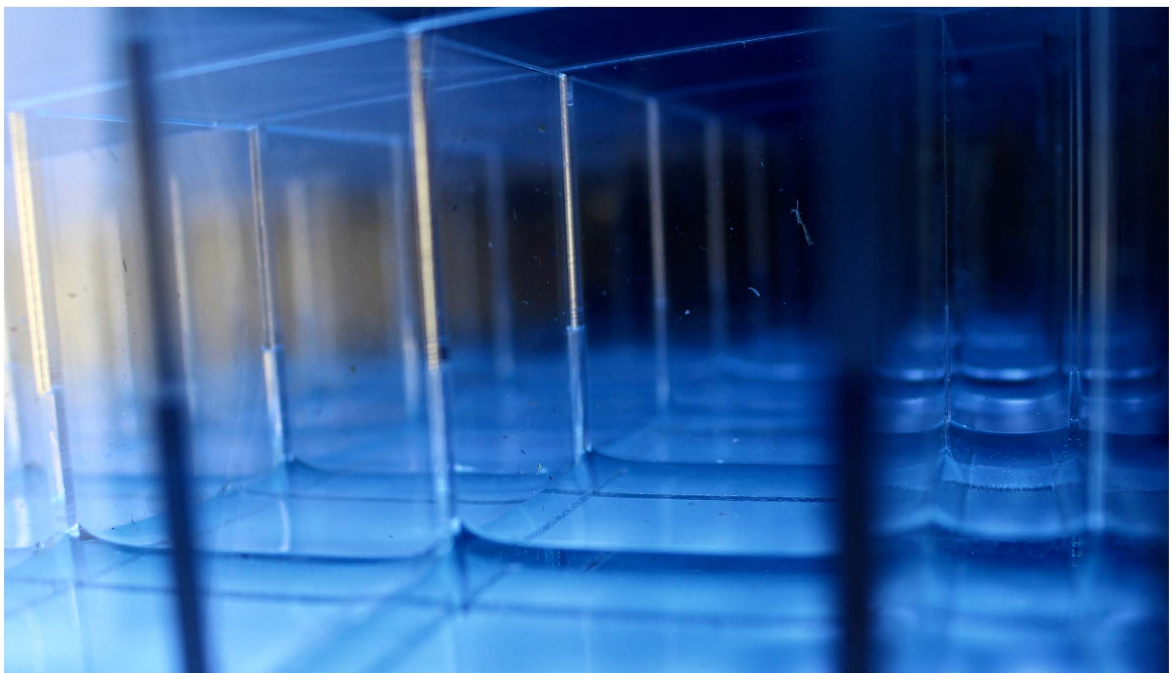

Figure 19. Water table V4 is currently being refined. Surface sagging prevents even flow across the entire testing bed surface. Leaks into the undercarriage and light table cast a blue hue on the testing surface, obscuring legibility. Nonetheless, a tectonic logic of nested vessels and integrated mechanisms for calibration emerges. Images: Author.

## Architecture

What architectural design insights about airflow are revealed by the three measures presented in this paper? This section reflects on these insights by exploring models of architecture suggested by the three frames of reference explored in this paper. Marey's wind tunnel photographs capture the technique he devised for measuring airflow rates as differential moving lines. In order to make air measurable, it was translated into moving smoke lines, making the 'non-visual phenomena object' of airflow visible and legible as a material system with distinct steady-state and turbulent flow patterns (Hight 2009). Marey's photographs also reveal that air, which ultimately had the capacity to keep heavy machines aloft, had substantial force-potential. The aerodynamic forms tested within Marey's wind tunnel suggest a model of architecture in which building takes its shape in response to the forces of air movement exerted upon it. In this model of architecture as environmental inscription, buildings appear as erosions with soft edges and trails, suggesting that they have, in effect, been shaped by the force of air.

Foster and Partner's 2001 unbuilt project, the Ventiform Building, exemplifies this model of architecture as environmental inscription (Figure 20). The project's name refers to ventifacts, "rocks that are carved into aerodynamic forms by windblown sand" (Gissen 2003, 20). An unbuilt speculation for a high rise building in southwest England, the project is presented in different forms and configurations, but two primary governing principles remain the same. First, a boomerang form in plan creates surfaces that smoothly direct air movement around the building, creating intentional wind pockets on the leeward side. Second, a wind turbine is integrated into the building, necessitating orientation and configuration that maximises high speed wind through the turbine. The building appears as a crystallisation of an aerodynamic

moment and an optimisation of a prevailing wind condition.

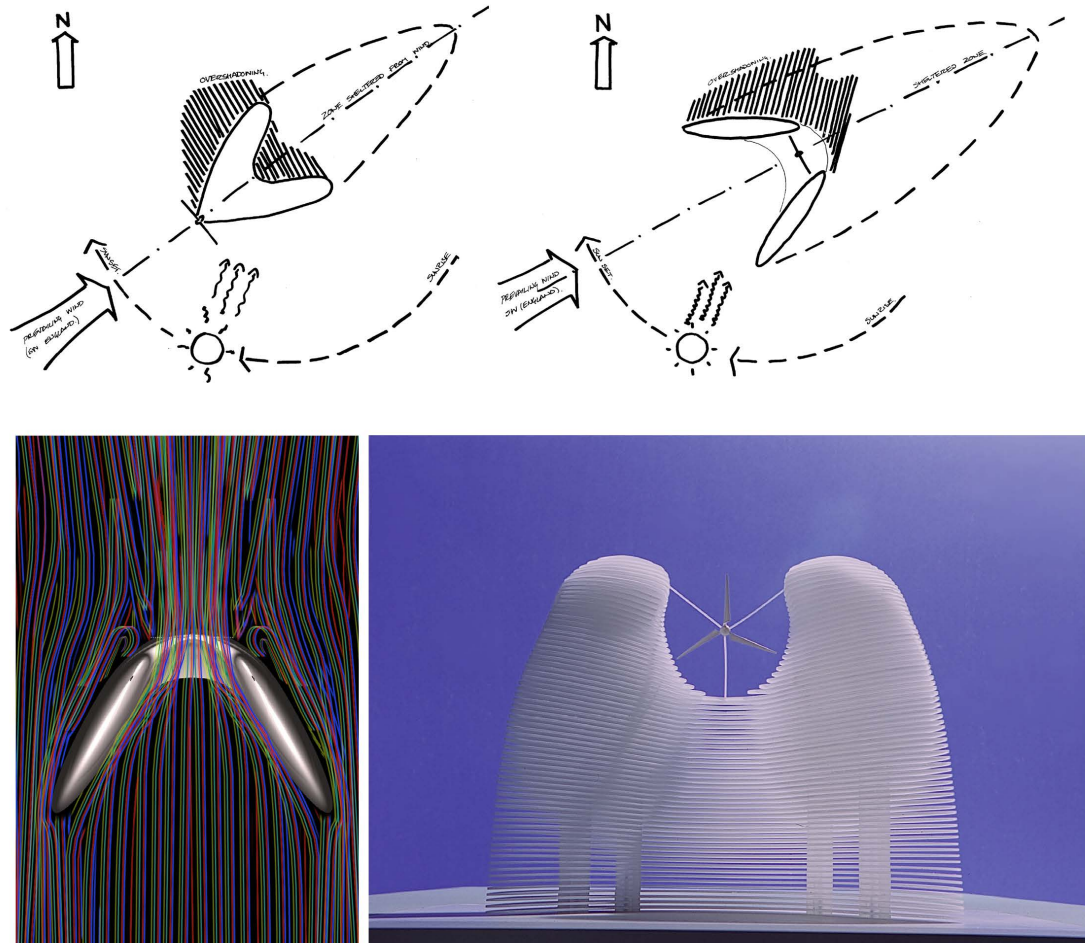

Figure 20. Foster + Partner's 2001 unbuilt project, the Ventiform Building, exemplifies the model of architecture as environmental inscription suggested by the obstructions placed in Marey's wind tunnel. The building appears as a crystallization of an aerodynamic moment and an optimization of a prevailing wind condition. Sketch: (top) Norman Foster. (bottom left): Foster + Partners. (bottom right) Nigel Young / Foster + Partners.

In the second frame of reference, Marey's wind tunnel is presented as an instrument of environmental mediation. On the one hand, it is composed of componentry designed to actively generate, speed up, direct, straighten, and outlet airflow. On the other hand, it is a sensitive device measuring airflow deviations, registering exterior disturbance within the interior of the testing bed. This reading of wind tunnels and water tables as both subtle and not-so-subtle environmental mediators suggests a model of architecture as environmental instrument. In this

model, buildings are dynamic, actively mediating between interior and exterior conditions through adjustable componentry.



Figure 21. Glenn Murcutt's Marika-Alderton House (1994) in Australia's Northern Territory exemplifies the model of architecture as environmental instrument suggested by Marey's wind tunnel. The house is responsive and dynamic. It is composed of architectural elements with particular causal relations between those components and air movement. Source: Murcutt (permissions pending).

Glenn Murcutt's the Marika-Alderton House, also known as House for an Aboriginal

Community, completed in 1994 in Australia's Northern Territory, exemplifies this approach (Figure 20). The form of the building is similar to many of Murcutt's projects; a rectangular single room-width building that facilitates cross-ventilation is capped with a large overhanging corrugated steel shed roof that sheds water and protects from intense tropical sun. In this case, the building is particularly porous, with no glazing, which is a liability during a cyclone. Both off-the-shelf and custom componentry allows for careful environmental calibration, or instrumental tuning, of the house. Hinged hopper plywood panels extend along the full perimeter of the building except when adjacent to sleeping areas. These, combined with vertical slatted wall cladding ensure that the building can continuously breathe with varying intensities. Carter notes that the east and west ends of the buildings can be opened "to catch every possible current and eddy" (2011, 376). Tapering vertical fins profiled similar to airplane wings act as solar breaks while also "reducing lateral wind velocity" (Frampton 2002, 2). The house is raised on stilts, providing access to higher, cooler air movement. Murcutt specified very particular roof vents designed for racing yachts, 'wind workers' pivot, actively registering wind movement and direction; moreover, they are attached to tubes that extend through the house, drawing air from underneath to equalise cyclonic pressure (Murcutt 2002).

The house is anything but aerodynamic in shape. This is a crucial design consideration for buildings that actively encourage airflow design in turbulence rather than designing it out. "While objects created to move through air are designed to lower resistance against air, buildings designed for natural ventilation need to build up resistance in order to facilitate the flow" (Battaglia and Passe 2015, 17). Air movement is directed through or blocked by moving shutters, sliding panels, twirling ventilation caps, and hinging wall panels. The house is responsive and dynamic; it is composed of building elements with particular causal relations between those

components and air movement.

The third frame of reference in this paper were contemporary wind tunnels and water tables prototypes, which reveal material reciprocities between fluids and the solid materials that contain and direct them. Air and water act as measures of constructional anomalies such as material deflections and gaps not visible otherwise. Working dialogically between the two material sensibilities prompts development of tectonic strategies and increased attention to details and joints. The prototyping process points less to a model of architecture and more to a model of design in which fluid materials are used to highlight properties of their solid counterparts. Air exerts destabilizing forces on continuous surfaces, requiring increased rigidity; water pools along deflected surfaces, and leaks through inadvertent gaps, requiring tighter fit. Wind tunnel prototyping lead to a tectonic logic of smooth material and geometric transitions, lightweight material rigidity and assembly stability. This can be traced directly through the development of joints. V1 lacks a clear approach to material intersections; V2 is largely a construction of smooth-fit lapped joints; V4 is a construction of gasketed joints. The tectonics of wind tunnels thus operate somewhere between the aerial domain of aeronautics and the grounded domain of architecture. Water table prototypes reflected a different tectonic trajectory. Creating controlled steady-state environments requiring machining levels of precision that are facilitated by digital fabrication. A tectonic logic of nested vessels and integrated mechanisms for calibration developed in response.

The significance of this research is that it places environmental models both within a broader historic and a more nuanced contemporary architectural design context. Close reading, designing, and prototyping environmental models offer designers direct insights into the material properties and behavioural tendencies of airflow, about working between controlled interior and

erratic exterior environments, and about the reciprocities between active, moving materials and solid obstructions. Whereas environmental models have conventionally been used as engineering tools for quantitative verification of finalised building designs, designing environmental models reveals their capacity to act as generative design tools. Environmental models provide a lens for understanding, viewing, and intervening within the fluid conditions that surround, activate and impact building shape, form, and material assembly. They reveal some of the forces and material exchanges between relatively static building materials and the shifting, fleeting, dynamic atmospheric conditions surrounding and activating them.

Environmental models make the ‘non-visual phenomena object’ of airflow visible and materially tangible, giving its latent tectonic and form-giving properties design agency.



## References

- Addington, D.M. 2007. "Good-bye, Willis Carrier" in *The Green Braid: Towards an Architecture of Ecology, Economy, and Equity* edited by Tanzer, K. and R. Longoria. Routledge.
- Addis, B. 2013. "Toys that save millions--a history of using physical models in structural design" in *The Structural Engineer*, 91(4): 12-27.
- Aronin, J.E. 1963. *Climate and Architecture: Progressive Architecture Book*. Reinhold Publishing Corporation.
- Barlow, J., W. Rae, A. and Pope. 1999. *Low-Speed Wind Tunnel Testing*, 3<sup>rd</sup> ed. Wiley.
- Battaglia, F. and U. Passe. 2015. *Designing Spaces for Natural Ventilation: An Architect's Guide*, Routledge.
- Braun, M. 2008. *Picturing Time: The Work of Étienne-Jules Marey*, University of Chicago Press.
- Cantrell, B. and J. Holzman. 2016. *Responsive Landscapes: Strategies for Responsive Technologies in Landscape Architecture*. Routledge.
- Carter, N. 2011. "A Site Every Design Professional Should See: The Marika-Alderton House, Yirrkala" in *Design and Culture*, 3(3): 375-378.
- Daston, L. and Galison, P. 2010. *Objectivity*, MIT Press.
- Didi-Huberman, G. 2004. *Mouvements de l'air : Etienne-Jules Marey, photographe des fluids*. Editions Gillamard.
- Emori, I. and D. Schuring. 1977. *Scale Models in Engineering: Fundamentals and Applications*. Pergamon.
- Frampton, K. 2002. *The Architecture of Glenn Marcus Murcutt*. The Pritzker Architecture Prize. The Hyatt Foundation. 1-3.
- Gissen, D. 2003. *Big and Green: toward Sustainable Architecture in the 21<sup>st</sup> Century*. Princeton Architectural Press.
- Hight, C. 2009. "The New Somatic Architecture." *Harvard Design Magazine*, 30. 24-31.
- Hinterwalder, I. 2013. "Parallel Lines as Tools for Making Turbulence Visible." *Representations*, 124(1):1-42.
- Hinterwaldner, I. 2014. "Model building with wind and water: Friedrich Ahlborn's photo-optical flow analysis." *Studies in History and Philosophy of Science Part A*, 49:1: 1-17.
- Hoffmann, C. 2013. "Superpositions: Ludwig Mach and Étienne-Jules Marey's studies in Streamline Photography." *Studies in History and Philosophy of Science*, 44:1-11.



- Lechner, N. 2009. *Heating, Cooling, and Lighting, Sustainable Design Methods for Architects*, 3<sup>rd</sup> ed. John Wiley and Sons.
- Lee, J. 1999. "The Origin of the Wind Tunnel in Europe, 1871-1900." *Air Power History*, 45(2): 6-15.
- Manning, E. 2008. "Grace Taking Form: Marey's Movement Machines." *Parallax*, 14: 82-91.
- Manaugh, G. 2013. *Landscape Futures: Instruments, Devices and Architectural Inventions*. Aktar.
- Marey, E.-J., 1879. *Animal Mechanism: A Treatise On Terrestrial and Aerial Locomotion*. New York: D. Appleton and Company.
- Marey, E.-J., 1895. *Movement*, New York: D. Appleton and Company.
- Marey, E.-J. 1876. "The Graphic Method in the Experimental Sciences, and on its Special Application to Medicine." *The British Medical Journal*, Jan 15: 65.
- Merzkirch, W. 1987. *Flow Visualisation*, 2<sup>nd</sup> ed. Elsevier.
- Mueller, T. 1983. "Smoke Visualisation in Wind Tunnels." *Astronautics and Aeronautics*, January 1953: 51-61.
- Murcutt, G. 2002. "House for an Aboriginal Community" in *Glen Murcutt. Feathers of Metal*, El Croquis, 163/164: 219-249
- Munitxa, M.L., 2015. "Robot-Aided Interactive Design for Wind Tunnel Experiments" in *Robot 2015; Second Iberian Robotics Conference, Advances in Robotics*, Vol 2, edited by Reis, L.P., A.P. Moreira, and P. Lima. Springer.
- Musée d'Orsay. n.d. "Movements of Air Étienne-Jules Marey (1830-1904) Photographer of Fluids." [http://www.musee-orsay.fr/fr/evenements/expositions/aux-musees/presentation-generale/article/mouvements-de-lair-etienne-jules-marey-1830-1904-photographe-des-fluides-4216.html?S=&tx\\_ttnews%5Bsword%5D=marey&tx\\_ttnews%5BbackPid%5D=252&cHash=b147a54ab3&print=1&no\\_cache=1&](http://www.musee-orsay.fr/fr/evenements/expositions/aux-musees/presentation-generale/article/mouvements-de-lair-etienne-jules-marey-1830-1904-photographe-des-fluides-4216.html?S=&tx_ttnews%5Bsword%5D=marey&tx_ttnews%5BbackPid%5D=252&cHash=b147a54ab3&print=1&no_cache=1&)
- Ramirez, E. 2013. "Airs of Modernity 1881-1914." PhD diss., Princeton University.
- Rico, E. and E. Llabres Valls. 2016. "Interacting with Simulations." *Interdisciplinary Journal of Landscape Architecture*: 60-65.
- Robinson, A. 2014. "Designing Fluvial Sites: Digitally Augmented Physical Hydraulic Modeling." SimAUD, Proceedings of the Symposium on Simulation for Architecture & Urban Design: 21.
- Scientific American. 1902. "The Experimental Study of the Motion of Fluids, 1902." *Scientific American*, 86: 75-76.