

1 **Development of a novel off-grid drinking water production system integrating**
2 **electrochemically activated solutions and ultrafiltration membranes.**

3 **Author Names:**

4 Gillian E. Clayton¹; Robin M.S. Thorn¹; Darren M. Reynolds¹

5 **Affiliation:**

6 ¹Centre for Research in Biosciences, Coldharbour Lane, University of the West of England,
7 Bristol, BS16 1QY, United Kingdom

8 **Corresponding Author:**

9 Professor Darren Reynolds. Email: darren.reynolds@uwe.ac.uk

10 **Abstract**

11 Approximately 800 million people live without clean drinking water. Diarrhoea is responsible
12 for between 1.7 and 2 million deaths each year (primarily children) which are the result of
13 poor drinking water quality and sanitation. The main aim of this study was to demonstrate
14 the production of drinking water from a raw water source using an off-grid drinking water
15 production system. The off-grid drinking water production system (DWPS) developed at
16 UWE Bristol, combines an ultra-filtration (UF) system with in situ generation of
17 electrochemically activated solutions (ECAS). ECAS has two functional roles within the
18 system; to manage biofilms within the UF system and as a disinfectant. Integrated in-situ
19 probes (pH, oxidation reduction potential, chlorine, conductivity and dissolved oxygen)
20 coupled with a water quality sensing network (pH, water temperature, conductivity and
21 dissolved oxygen) enabled real time monitoring of; the operational efficiency of the DWPS,
22 and the physicochemical parameters of both the raw water source and the produced drinking
23 water. Spot samples of both raw and treated water were sent for independent chemical and
24 microbial analysis at an accredited laboratory which demonstrated that the DWPS produced

25 biologically safe potable drinking water according to the Drinking Water Inspectorate (DWI)
26 standards. Samples from the raw water source were shown to be consistently unsuitable for
27 human consumption, failing several of the DWI standards for potable water supply, including
28 coliform bacteria. This study demonstrated that the novel off-grid DWPS was capable of
29 producing DWI standard drinking water from a heavily biologically contaminated water
30 source.

31 **Keywords**

32 Off-grid; drinking water production; electrochemically activated solutions; ultrafiltration.

33 **1.0 Introduction**

34 An estimated 800 million people worldwide do not have access to improved drinking water
35 sources [1–3], with 1.2 billion people unable to access reliable electricity sources [4,5].
36 Therefore, there is a need for low energy technological solutions for the provisioning of safe
37 drinking water. By the end of the 21st century the global population is expected to increase to
38 9 - 10 billion [6], this is likely to generate increased stress on water and power (gas and
39 electricity) resources worldwide. Sufficient safe drinking water provisioning for an increasing
40 population will require the development of sustainable, reliable and robust water treatment
41 systems. The consumption of contaminated water, or poor water quality, is the cause of
42 between 1.7 and 2 million deaths each year from diarrhoeal diseases [7–10]. The majority of
43 these deaths are in developing or transitional countries which have inadequate sanitation
44 conditions [11], and do not have established water distribution systems. Developing
45 countries have economies with little industrial development, whilst aiming to improve quality
46 of life through increasing food and water security [12]. Transitional countries often have
47 emerging economies with a prominent secondary manufacturing industry; however, there is
48 still considerable rural and peri-urban poverty [12]. Developed countries have established
49 centralised water, gas and electricity (power) networks, which supply the majority of a
50 country's population with sufficient water, gas and electricity [4]. Developing and transitional

51 countries do not have the same established water and power networks, resulting in many
52 remote, rural or temporary communities unable to access reliable and safe power and
53 drinking water [4]. In developing or transitional countries, communities which are unable to
54 access improved water sources often live in remote or transitory locations, therefore
55 'centralised' drinking water treatment facilities and distribution systems are not sustainable
56 options from a financial or resource efficient perspective.

57 Research into decentralised, or off-grid, drinking water treatment systems for developing
58 countries has gained momentum due to unfeasible practicalities with centralised provision
59 [10,13–15], and are an important element in the process of reaching the Millennium
60 Development Goals. Some decentralised systems focus on rainwater harvesting [10,16,17],
61 solar based disinfection [18,19], or the physical removal of contaminants within treated water
62 through sand bed filters [20,21] or ultrafiltration (UF) [15,22]. Since the main drinking water
63 risks in developing countries are still associated with microbial contamination, many
64 decentralised systems continue to use established disinfection techniques such as UV [18],
65 chlorination [23,24], or ozonation [14]. Even when disinfection agents (e.g. chlorine) are
66 used, the presence of suspended material and colloids in the water can reduce their efficacy,
67 ultimately enabling bacterial growth after treatment [10]. In addition, these disinfection
68 techniques require the regular purchase, transportation and storage of hazardous chemicals
69 and for developing or transitioning countries, this can prove expensive and logistically
70 challenging. A key advantage of off-grid systems is the modular capability, whereby, the
71 production of drinking water output can be increased to cope with increasing
72 populations/demand.

73 Electrochemically activated solutions (ECAS), are known by several terms, the most
74 common being electrochemically activated water (ECAW), electrolyzed water (EW),
75 electrolyzed oxidising water (EOW) and mixed oxidant (MIOX) solutions. These solutions are
76 generated by passing a weak salt solution (e.g. NaCl), through an electrochemical cell,
77 whereupon a direct current is applied. Electrochemically activated solution generated at the

78 anode, referred to in this paper as ECAS, is acidic in nature and possesses antimicrobial
79 chemical species including hypochlorous acid (HClO) and other transient oxidative functional
80 groups [25–27]. ECAS have a short environmental legacy, reverting back to a saline solution
81 during chemical relaxation [25], and are often referred to as ‘green biocides’ [28,29]. These
82 solutions have been shown to have a beneficial application within; the fresh produce industry
83 [27,30–34], healthcare settings [25,26,35] and drinking water treatment [24,36,37], due to
84 extremely fast acting kill kinetics e.g. < 10 seconds [38,39].

85 The main aim of this study was to demonstrate the production of drinking water from a raw
86 water source (artificial water body) to Drinking Water Inspectorate (DWI) standards, using a
87 decentralised, off-grid, *drinking water production system* (DWPS). The European Council set
88 guidelines for water quality which is safe for human consumption [40], which is interpreted by
89 each European Union member state. In the United Kingdom the Drinking Water Inspectorate
90 (DWI) interprets and regulates drinking water quality.

91

92 **2.0 Materials and methods**

93 2.1 Off-grid drinking water production system

94 A technical schematic of the off-grid drinking water production system (DWPS) is shown in
95 Figure 1. Raw water, from an artificial water body (an urban drainage holding pond, UWE
96 Bristol, UK [N 51° 29' 56", W 2° 32' 39"]), is pumped to a settle tank within the drinking water
97 production system through an intake submersible filter pump (115 µm) and a reverse
98 flushing filter (100 µm). A peristaltic pump draws water from the settle tank into the UF
99 membrane columns ([0.02 µm] LineGuard UF-100, Pentair). ECAS is generated as per
100 details in Section 2.2, and subsequently stored in the ECAS reservoir tank (100L). ECAS is
101 dosed directly into the DWPS pipework, immediately before (A) and after (B) the UF
102 membrane columns via automated peristaltic dosing pumps. Treated water is then stored in
103 the 400 L treated water tank. To monitor the health of the UF membranes, pressure gauges
104 are installed before and after the UF membrane columns.

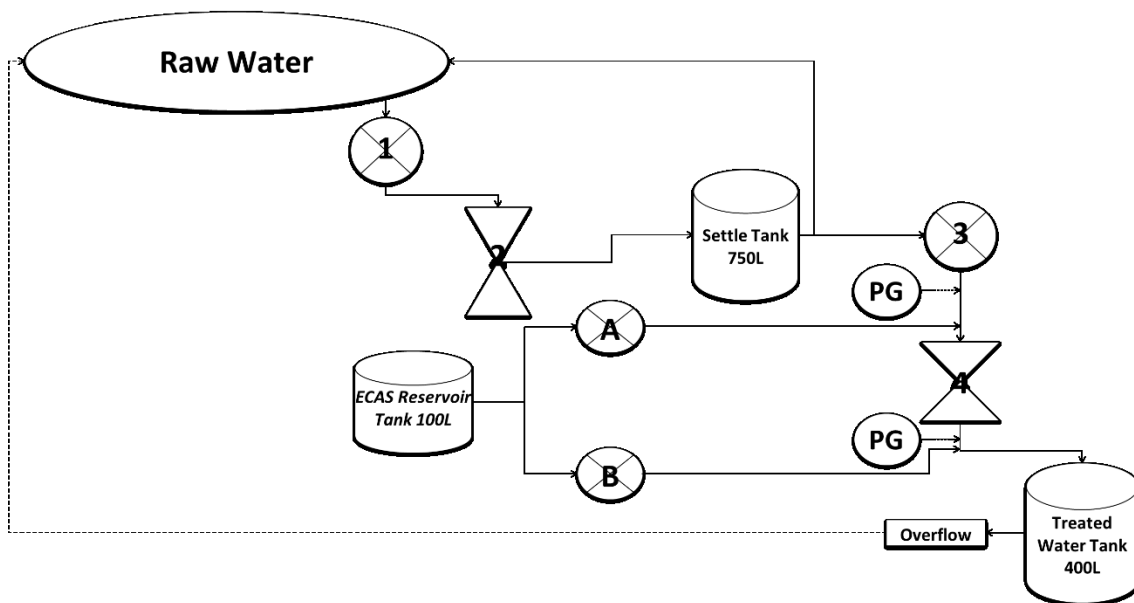

105

106

107 **Figure 1:** Technical schematic of the off-grid drinking water production system. Direction of arrows
108 refer to water flow direction. (1) Submersible filter pump (115 µm); (2) Reverse flushing filter (100 µm);
109 (3) Peristaltic pump; (4) UF membrane columns (0.02 µm); ECAS reservoir tank 100L for ECAS
110 generated outside of the DWPS; (A) & (B) ECAS peristaltic dosing pumps for delivering ECAS into the
111 bulk treated water stream; (PG) Pressure gauges.

112

113 2.2 Electrochemically activated solution (ECAS) generation

114 ECAS was generated using a 60 L ESOL™ generator (Bridge Biotechnology, Fife, Scotland)
115 through the electrolysis of a 1% (w/v) NaCl solution under a direct current (Figure 2).
116 Solutions were generated (anodic solution) to an oxidation reduction potential (ORP) of 1130
117 mV, and subsequently held and stored within a 100 L reservoir tank until required. Peristaltic
118 dosing pumps enabled precise dosing of ECAS directly into the DWPS pipework pre- and
119 post- ultrafiltration (UF) column membranes.

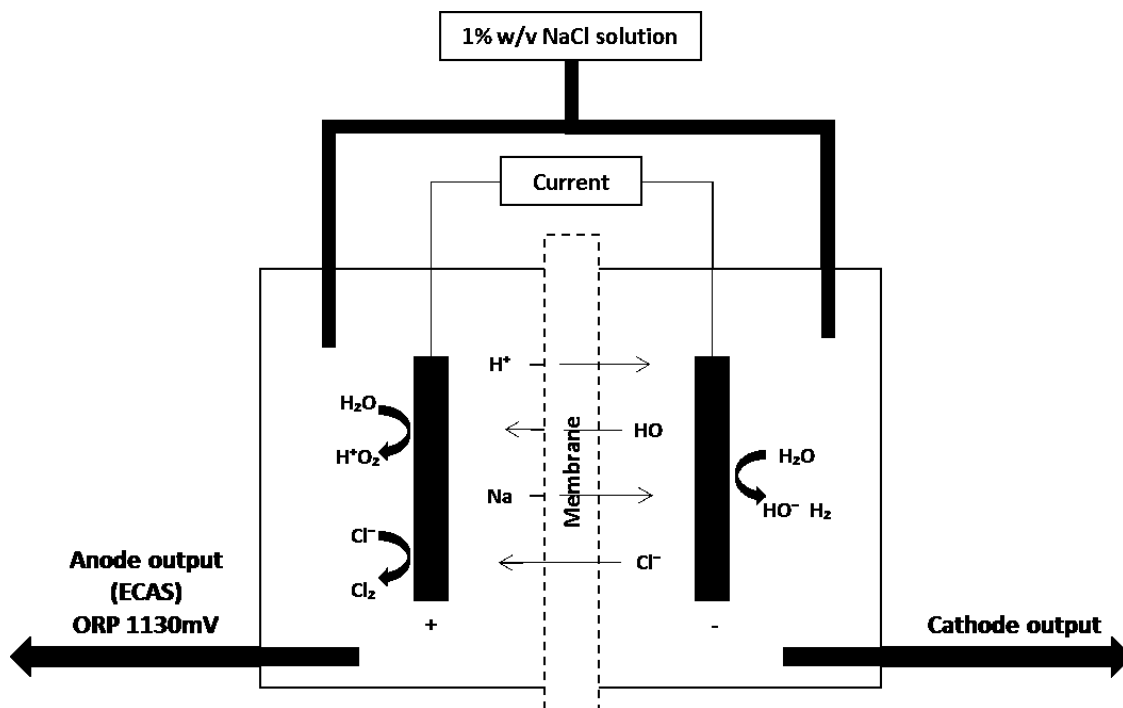

120

121 **Figure 2:** Schematic of ECAS generation. A direct current is applied across two electrodes, an anode
122 (+) and cathode (-) separated by a permeable ion exchange membrane, allowing constant perfusion
123 of an electrolyte solution (1% w/v NaCl). The anolyte solution generated (ECAS) has a high oxidising
124 potential, whilst the catholyte solution has a high reducing potential.

125

126 2.3 DWPS Field trials

127 Two field trials were performed. Field trial 1 consisted of dosing 0.5% (v/v) ECAS pre- and
128 post- UF membranes. Resulting in a total of 1% (v/v) ECAS dosed directly into the DWPS
129 pipework. Field trial 2, the control period, had no ECAS dosed pre- and post- UF

130 membranes, resulting in 0% (v/v) ECAS dosage into the DWPS pipework. Both field trials
131 were conducted over 16 operational days. The total time between the end of one field trial
132 and the start of next was 18 days. This downtime between trials allowed for UF membranes
133 to be thoroughly cleaned using alkaline and acid washes using sodium hypochlorite,
134 hydrochloric acid and sodium hypochlorite.

135

136 2.4 Water sampling and analysis

137 Six water samples (both raw water and treated water) were collected and sent for analysis
138 during each field trial. Water samples were collected from the raw water source, and the
139 treated water outlet within the DWPS, before being immediately transported to an
140 independent ISO 17025 accredited laboratory for standard suite analysis. See Table 1 for a
141 full list of parameters tested within the standard suite analysis.

142 To determine the significant difference between raw water and treated water samples
143 throughout field trial 1 and field trial 2, a *t-test* was performed for each parameter listed in
144 Table 1. A *P* value of <0.05 was considered significant. Graph construction and statistical
145 analysis was performed using GraphPad Prism version 5.00 for Windows (GraphPad
146 Software, San Diego, CA), and Microsoft Excel 2013 for Windows (Microsoft Corporation,
147 Redmond, WA).

148 Real-time monitoring of treated water quality (conductivity, oxidation reduction potential
149 [ORP], pH, dissolved oxygen and chlorine), as well as pre- and post- membrane pressures,
150 was performed using a WebMaster data logging system (Walchem, Holliston, MA, USA).

151 UF membrane health was determined by calculating the pressure differential across the UF
152 membrane column module (Equation 1 and Equation 2), and converting this to membrane
153 permeability, the industry standard for membrane health (Equation 3).

154 **Equation 1:** Filtration flux.

$$\text{Filtration flux (L}^{-1}\text{m}^{-1}\text{h}^{-1}\text{)} = \frac{\text{Feedflow [m}^3\text{h}^{-1}\text{]} \times 1000}{A \times B \text{ [m}^2\text{]}}$$

155 Whereby; UF feedflow is measured on the module, A = Number of membrane housings, and
156 B = Membrane area per membrane housing [m²]

157

158 **Equation 2:** Transmembrane pressure filtration.

$$\text{Transmembrane Pressure (TMP) filtration [bar]} = P_{T_{\text{feed}}} - P_{T_{\text{permeate}}}$$

159 **Equation 3:** Permeability UF module.

$$\text{Permeability UF module [L}^{-1}\text{m}^{-1}\text{h}^{-1}\text{]} = \frac{\text{Filtration flux (L}^{-1}\text{m}^{-1}\text{h}^{-1}\text{)}}{\text{Transmembrane Pressure (TMP) filtration [bar]}}$$

160

161 **3.0 Results and Discussion**

162 3.1 Field trial 1: 1% (v/v) total ECAS Dosing

163 Field trial 1, dosing 0.5% ECAS pre- and post- UF membranes, ran for 16 operational days.
164 Table 1 shows the biological, basic water parameters, chemical and metal analysis results
165 for the 6 water samples taken during DWPS operation. Over the entire sampling period all
166 raw water samples analysed prior to treatment failed to meet DWI standards, and were
167 deemed unsafe for human consumption (Table 1). All tested parameters for the DWPS
168 treated water samples were within the specified DWI limits. For example, Table 1 and Figure
169 3 demonstrate the achieved biological quality of drinking water produced using 1% (v/v) total
170 ECAS as a disinfectant.

171 Water that was treated by the DWPS was shown to contain zero (0 cfu 100 mL⁻¹) levels of
172 coliforms, *Escherichia coli*, Enterococci and *Clostridium perfringens*. The complete log
173 reduction of bacteria within heterotrophic plates counts at 37°C for 48 hours was achieved
174 for every treated water sample, except operational day 5 ([2 cfu mL⁻¹] Figure 3). However, all
175 treated water samples contained significantly lower heterotrophic bacteria at 37°C than in
176 raw water samples (Table 1), and there is no DWI maximum limit for heterotrophic plate
177 counts (37°C) [41]. Therefore treated water within field trial 1 was deemed fit for human
178 consumption.

179 The multi-step filtration within the DWPS (Figure 1) resulted in a significant reduction in
180 turbidity between raw water samples and treated water samples, whereby treated water
181 turbidity was within the DWI maximum limit of 4 FTU (Table 1).

182 The observed increase in the chloride concentration of treated water samples is due to
183 dosing an electrolysed saline solution (ECAS) directly into the water treatment system.
184 However, chloride concentrations for raw and treated water samples were consistently below
185 the DWI limit of 250 mg L⁻¹ (Table 1). Figure 4 shows the real-time free chlorine
186 concentration data of the treated water (using the in-line probes), whereby a reading was

187 automatically taken every minute. The frequent chlorine spikes are a result of UF
188 membranes back-flushing, which occur every 30 minutes, resulting in ECAS being dosed
189 into the DWPS pipework in the absence of bulk water flow. Despite this, free chlorine
190 concentrations within the treated water were significantly below the WHO recommended
191 concentration of 5 mg L⁻¹ free chlorine in drinking water.

192 It is evident from table 1, that there were significant reductions in aluminium, iron, lead,
193 manganese and zinc concentrations in the treated water compared to the raw water source.
194 The reduction in these metals is due to the multi-step filtration process within the DWPS. A
195 significant increase of sodium concentration in treated water samples is due to dosing an
196 electrolysed saline solution (ECAS) directly into the water treatment system. All metals levels
197 measured in the treated water were below the DWI limit for safe drinking water.

198 Permeability of the UF membranes initially decreased prior to stabilising, indicating no
199 significant blocking or biofouling of the UF columns during the course of this field trial (Figure
200 5). Biofouling can be a result of biofilm formation [42,43]; however, ECAS has been shown to
201 be effective in inhibiting biofilm formation [25,37,44] The regular spikes in permeability are a
202 result of UF membrane back-flushing every 30 minutes, which artificially impacts on the
203 measured pressure differential across the columns.

204 3.2 Field Trial 2: 0% ECAS Dosing (Control Period)

205 Table 1 shows the biological, basic water parameters, chemical and metal analysis results
206 for the 6 water samples taken during DWPS operation in the absence of ECAS dosing. All
207 water samples taken and analysed from the raw water source failed to meet DWI
208 specifications and were deemed unsafe for human consumption (Table 1).

209 During Field Trial 2 (in the absence of ECAS dosing), the DWPS did not produce drinking
210 water to DWI standards. Coliform bacterial counts exceeded the maximum allowance of 0
211 cfu 100 mL⁻¹, producing a mean result of 76.67 cfu mL⁻¹. Non-lactose fermenters within
212 treated water samples were significantly higher compared to raw water samples. However,

213 there were no recovered presumptive *E. coli*, *E. coli*, *Clostridium perfringens* and enterococci
214 from treated water samples (Table 1).

215 Table 1 demonstrates that multi step filtration within the DWPS resulted in a significant
216 reduction in turbidity between the raw water and the treated water, bringing the treated water
217 sample to within DWI limits. No significant difference was observed between the raw water
218 and treated for any of the measured chemical parameters (ammonium, chloride, nitrate,
219 nitrite, orthophosphate, silica and sulphate), and were within the DWI limits. The free
220 chlorine concentration of treated water over the 16 operational days was below the limit of
221 reliable detection for the in-line sensor ($< 0.12 \text{ mg L}^{-1}$), which is expected since no ECAS
222 was dosed into the DWPS.

223 Metal analysis of the raw and treated water samples resulted in significant reduction of
224 aluminium, iron, lead and zinc (Table 1). Since this was observed in both field trials
225 (presence and absence of ECAS dosing), it can be concluded that reduction is due to the
226 multi-step filtration process alone within the DWPS.

227

228 **Table 1:** Analytical results of the raw water samples and treated water samples. Field trial 1: 1% total ECAS dosing UF membrane. Field trial 2: Control, 0%
 229 ECAS UF membrane. Results shown are the calculated mean from the independent ISO 17025 accredited laboratory reports (n=6 ±SD). Significant
 230 difference (Sig. diff) calculated through an unpaired, two tailed t-test, with a confidence interval of 95% (** = p<0.01; * = p<0.05; ns = not
 231 significant). **Bold figures** = Above DWI limit value.

Water type	UNIT	FIELD TRIAL 1 (1% total ECAS dosing)					FIELD TRIAL 2 (Control; 0% ECAS dosing)					DWI Limit
		Raw water		Treated water		Sig. diff	Raw Water		Treated water		Sig diff.	
		Mean	SD	Mean	SD			Mean	SD	Mean		SD
BIOLOGICAL												
Plate count (2 day @ 37°C)	/ml	538.83	753.19	0.33	0.82	***	672.60	778.93	457.33	518.80	ns	
Plate count (3 day @ 22°C)	/ml	2685.33	770.77	2690.67	757.71	ns	12769.40	11209.42	2330.00	596.80	ns	
Non-lactose fermenters	/100ml	33.33	51.64	1.17	2.86	***	0.00	0.00	13.67	33.48	***	
Presumptive coliform bacteria	/100ml	49.17	43.19	0.00	0.00	***	1913.33	3977.37	86.50	66.51	ns	
Coliform bacteria	/100ml	12.00	8.29	0.00	0.00	***	1913.33	3977.37	76.67	73.55	ns	0
Presumptive <i>E.coli</i>	/100ml	1.50	0.71	0.00	0.00	***	573.33	832.99	0.00	0.00	***	
<i>Escherichia coli</i>	/100ml	1.50	0.71	0.00	0.00	***	573.33	832.99	0.00	0.00	***	
<i>Clostridium perfringens</i>	/100ml	95.83	11.70	0.00	0.00	***	115.33	82.65	0.00	0.00	***	0
Enterococci	/100ml	52.67	42.04	0.00	0.00	***	88.67	88.59	0.00	0.00	***	0
BASIC WATER PARAMETERS												
Alkalinity		139.00	2.65	131.50	7.78	ns	155.00	31.11	154.00	31.11	ns	
Colour (spectrophotometer)	mg L ⁻¹ Pt/Co	5.60	0.55	4.00	1.79	ns	8.33	1.37	7.67	1.53	ns	
Colour estimated	Deg Hazen	5.00	0.00	5.00	0.00	ns	5.00	0.00	5.00	0.00	ns	
Conductivity	µS cm ⁻¹ @ 20°C	708.00	69.80	764.17	151.18	ns	610.33	53.71	613.17	52.53	ns	2500
pH		8.88	0.18	8.70	0.37	ns	8.33	0.66	8.22	0.69	ns	6.5 - 10
Total hardness	Mg Ca L ⁻¹	118.67	13.31	114.93	16.75	ns	109.00	11.33	102.93	8.23	ns	
Turbidity	FTU	15.60		0.34	0.27	***	27.33	6.86	0.19	0.13	***	4
CHEMICAL ANALYSIS												
Ammonium	mg L ⁻¹	0.05	0.04	0.03	0.01	ns	0.27	0.29	0.21	0.16	ns	0.5
Chloride	mg L ⁻¹	96.50	7.66	137.50	5.54	***	63.17	3.54	62.17	3.54	ns	250
Nitrate	mg L ⁻¹	3.50	0.46	3.77	0.42	ns	1.02	0.55	1.08	0.71	ns	50
Nitrite	mg L ⁻¹	0.05	0.01	0.04	0.01	ns	0.06	33.68	0.38	33.21	ns	0.5

Water type	UNIT	FIELD TRIAL 1 (1% total ECAS dosing)					FIELD TRIAL 2 (Control; 0% ECAS dosing)					DWI Limit
		Raw water		Treated water		Sig. diff	Raw Water		Treated water		Sig diff.	
		Mean	SD	Mean	SD		Mean	SD	Mean	SD		
Orthophosphate	mg L ⁻¹	0.10	0.02	0.12	0.02	ns	0.09	0.08	0.12	0.08	ns	
Silica	mg L ⁻¹	0.40	0.20	0.45	0.35	ns	0.50	0.74	0.41	0.58	ns	
Sulphate	mg L ⁻¹	158.00	40.31	156.83	36.86	ns	126.00	13.53	129.00	13.00	ns	250
METAL ANALYSIS												
Aluminium	µg L ⁻¹	256.67	183.16	16.67	5.16	**	463.33	124.85	23.33	5.77	***	200
Cadmium	µg L ⁻¹	0.12	0.04	0.10	0.00	ns	0.10	0.00	0.10	0.00	ns	5
Calcium	mg L ⁻¹	103.45	11.07	100.28	14.07	ns	95.50	9.78	92.40	6.22	ns	
Copper	mg L ⁻¹	0.01	0.00	0.01	0.00	ns	0.01	0.00	0.01	0.01	ns	
Iron	µg L ⁻¹	316.67	180.85	10.00	0.00	***	548.33	160.18	10.00	0.00	***	200
Lead	µg L ⁻¹	5.38	2.43	0.62	0.26	***	8.57	2.38	0.37	0.20	***	25
Magnesium	mg L ⁻¹	9.28	1.36	8.95	1.67	ns	8.22	0.91	7.50	0.66	ns	
Manganese	µg L ⁻¹	21.00	3.85	4.33	1.97	***	62.67	32.96	25.40	23.89	ns	50
Nickel	µg L ⁻¹	2.00	0.00	2.00	0.00	ns	1.68	0.78	1.70	0.73	ns	
Potassium	mg L ⁻¹	3.90	0.49	3.65	0.57	ns	3.87	0.38	3.58	0.34	ns	
Sodium	mg L ⁻¹	53.17	4.02	75.83	3.66	***	37.50	1.87	36.83	1.33	ns	
Zinc	µg L ⁻¹	35.00	13.78	11.67	4.08	**	36.00	15.17	18.00	8.37	*	

232

233

234

**Field trial 1:
1% total ECAS Dosing**

**Field trial 2:
0% ECAS Dosing (Control)**

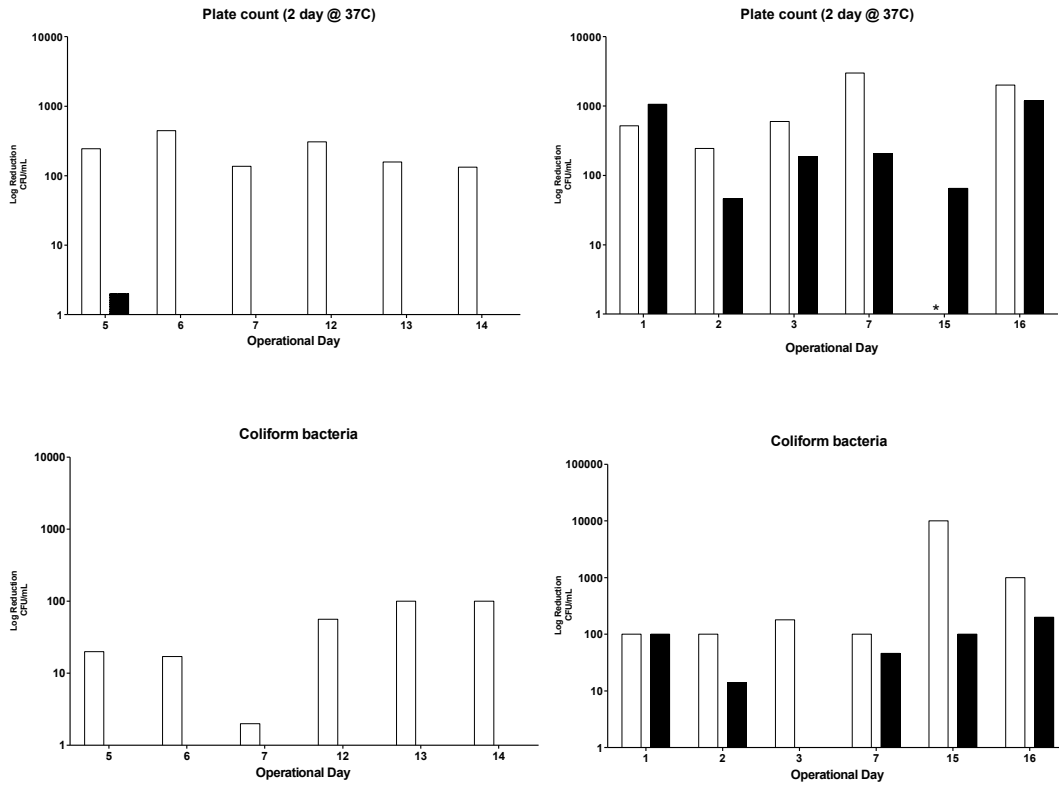

235

236 **Figure 3:** Heterotrophic plate count and coliform bacteriological results for water samples taken
 237 during Field Trial 1 (1% total ECAS dosing) and Field Trial 2 (control; no dosing). White bars
 238 represent raw water samples. Black bars represent treated water samples. Data taken from
 239 independent ISO 17025 accredited laboratory reports (n=1 per sampling day).

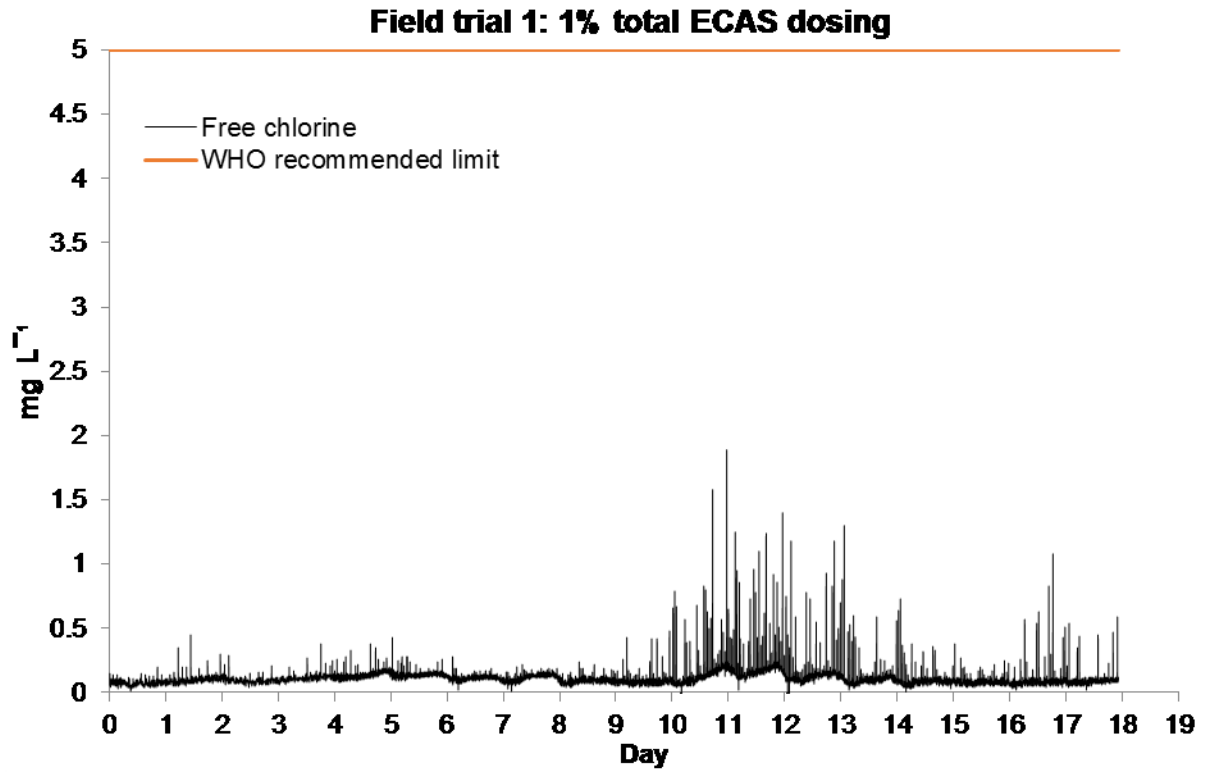

240

241 **Figure 4:** Free chlorine concentration (mg L⁻¹) of treated water samples (as recorded by the in-line
242 DWPS probe) for Field Trial 1 (1% total ECAS dosing).

243

244

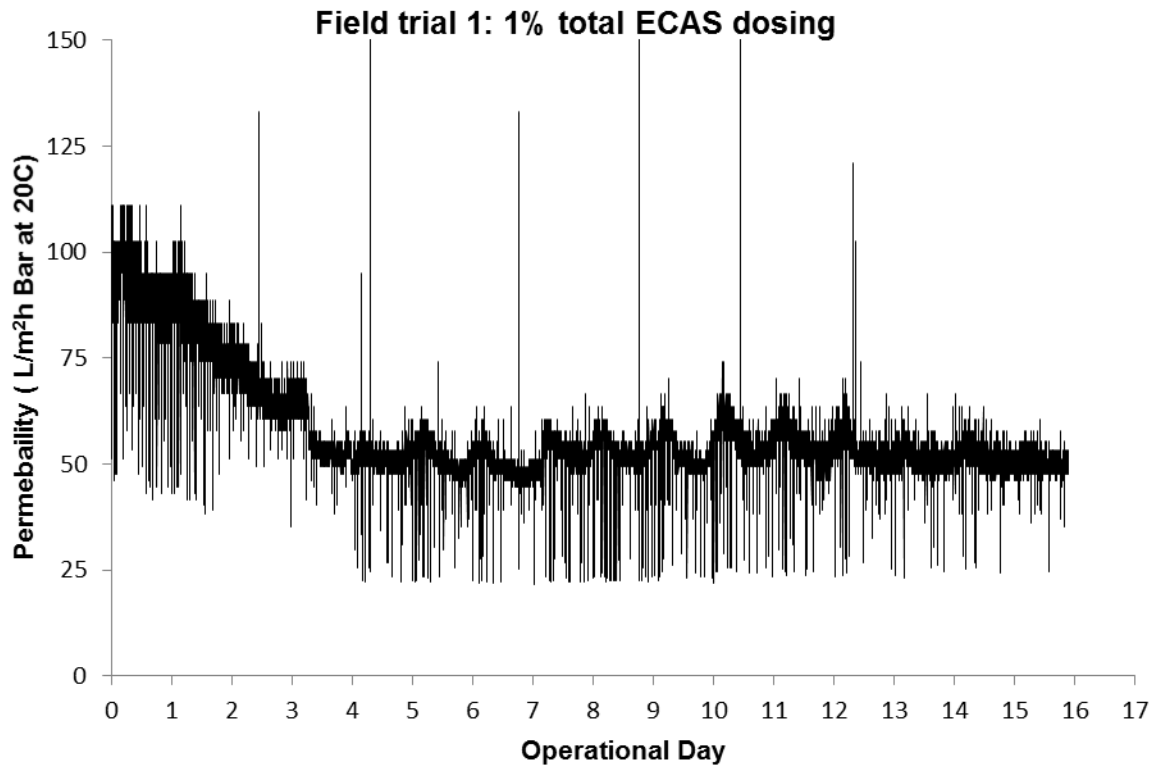

245

246 **Figure 5:** UF membrane column permeability within the drinking water production system during Field
247 trial 1 (1% total ECAS dosing).

248

249 **4.0 Conclusions**

250 Two field trials were conducted over two 16 day periods to evaluate the off-grid drinking
251 water production system shown in Figure 1. Field trial 1 performed direct dosing of 1% (v/v)
252 total ECAS into the DWPS pipework, pre- and post- UF membranes. Field trial 2 was a
253 control period, whereby the DWPS was operated in the absence of ECAS (0% ECAS
254 dosing) pre- and post- UF membranes.

255 All raw water source samples taken throughout the two field trials failed to meet DWI
256 standards and were deemed unsafe for human consumption.

257 During the control period (Field trial 2) all treated water samples were within DWI limits for
258 basic, chemical and metal parameters. However, the treated water produced was not
259 biologically safe due to the presence of coliform bacteria (Table 1 and Figure 3).

260 The analysis of all treated water samples resulting from field trial 1, demonstrated that the
261 off-grid DWPS was consistently capable of producing DWI standard drinking water, with all
262 basic, biological, chemical and metal parameters falling within the DWI threshold limits
263 (coliform bacteria, *Clostridium perfringens*, enterococci, conductivity, pH, turbidity,
264 ammonium, chloride, nitrate, nitrite, sulphate, aluminium, cadmium, iron, lead and
265 manganese).

266 In particular, the microbiological results from field trial 1 treated water samples demonstrated
267 the importance of ECAS dosing in the production of biologically safe drinking water to DWI
268 standards.

269 The stable permeability of the UF membranes during field trial 1 (whereby 0.5% (v/v) ECAS
270 was dosed pre-UF membranes), indicates that ECAS may help manage biofilm formation on
271 the UF membranes. During Field trial 2 (control; no dosing) greater fluctuations in
272 permeability within the UF membranes was observed, indicative of less stability, and
273 possible biofilm formation (data not shown). This inference of reduced biofilm formation,

274 reducing the possibility of biofouling using 0.5% (v/v) ECAS dosing pre-UF membranes,
275 requires further investigation.

276 Through a systems based hazard analysis the critical control points of the DWPS focus on
277 the in-line monitoring parameters, specifically ORP and free chlorine. Two key critical
278 variables are continuously measured in the WebMaster data logger, chlorine and ORP,
279 ensuring the risks of biological and physicochemical contamination in the DWPS final treated
280 water are minimised. The guideline value for chlorine is 5 mg L⁻¹, a European requirement
281 for ensuring adequate residual disinfection within distribution systems. In addition, due to the
282 nature of ECAS as a disinfectant; high ORP (+1130 mV), low free chlorine concentration,
283 compared to conventional chlorination, and very fast acting kill kinetics (< 10 seconds), ORP
284 is a key parameter to ensure production of biologically safe drinking water. Regular spot
285 sampling of the treated water for biological, basic, chemical and metal analysis is required to
286 ensure DWI compliance. A complete assessment regarding the hazards and critical control
287 points of the DWPS shall be carried out as part of any future work.

288 This study has shown that a novel off-grid drinking water production system can produce
289 DWI standard drinking water from a heavily biologically contaminated water source, when a
290 1% (v/v) total ECAS dosing regimen is implemented. The DWPS was developed with the
291 intention of use in a wide variety of applications and locations, such as developing and
292 transitional countries, many of which lack established centralised water treatment networks.
293 The potential modular and scalable capability of the DWPS could be beneficial in remote,
294 rural or temporary communities, which can have fluctuating populations. The self-contained
295 nature of the DWPS, all filtration and disinfection processes are within the DWPS (except for
296 intake filter pump), could be beneficial for temporary communities such as long-term
297 research expeditions, or during disaster relief efforts. Long-term field trials are now required
298 to obtain data for more representative applications, such as raw water sources from surface
299 and ground waters, which have differing 'contaminants' (e.g. fertilisers, heavy metals, faecal
300 contamination), ensuring the DWPS is capable and versatile in a wide variety of applications.

301 Investigations into the energy requirements for the DWPS are currently being conducted to
302 ensure that the DWPS is robust and reliable for long-term operation.

303 **Acknowledgements**

304 This study was funded by Portsmouth Aviation Ltd. The authors would like to express their
305 sincere thanks to Mr Scott Lowson for his assistance in the design and fabrication of the
306 DWPS.

307 **References**

- 308 [1] Unicef, World Health Organization, Progress on Drinking Water and Sanitation - 2014 update,
309 World Health Organization, Geneva, 2014.
- 310 [2] R. Ardakanian, J. Liebe, L.M. Bernhart, Water for Life 2005 - 2015: Report on the
311 achievements during the International Decade for Action, UN-Water, Germany, 2015.
312 <http://www.unwater.org/publications/publications-detail/en/c/282474/>.
- 313 [3] World Health Organization, Drinking-water - Fact sheet N°391, 2015 (2015).
314 <http://www.who.int/mediacentre/factsheets/fs391/en/>.
- 315 [4] A. Ramirez, Energy Access, (2014). http://www.un-energy.org/cluster/energy_access
316 (accessed January 13, 2016).
- 317 [5] International Energy Agency, World Energy Outlook, (2016).
318 <http://www.worldenergyoutlook.org/resources/energydevelopment/> (accessed January 13,
319 2016).
- 320 [6] United Nations, WORLD POPULATION TO 2300, Department of Economic and Social Affairs
321 Population Division, New York, 2004.
322 <http://www.un.org/esa/population/publications/longrange2/WorldPop2300final.pdf>.
- 323 [7] E. Corcoran, C. Nellemann, R. Baker, R. Bos, D. Osborn, H. Savelli, Sick Water? The central role
324 of wastewater management in sustainable development., United Nations Environmental
325 Programme, United Nations HABITAT and GRID-Arendal, 2010.
326 http://www.unep.org/pdf/SickWater_screen.pdf (accessed January 14, 2016).
- 327 [8] L.C. Simoes, M. Simoes, Biofilms in drinking water: problems and solutions, RSC Adv. 3 (2013)
328 2520–2533. doi:10.1039/C2RA22243D.
- 329 [9] D.S. Lantagne, W. Gallo, SAFE WATER FOR THE COMMUNITY A Guide for Establishing a
330 Community-Based Safe Water System Program The following individuals provided valuable
331 assistance in the form of original material or critical review: Centers for Disease Control and
332 Prevention, Atlanta, 2008.
- 333 [10] M. Peter-Varbanets, C. Zurbrügg, C. Swartz, W. Pronk, Decentralized systems for potable
334 water and the potential of membrane technology, Water Res. 43 (2009) 245–265.
335 doi:10.1016/j.watres.2008.10.030.
- 336 [11] A. Pruess-Uestuen, R. Bos, F. Gore, J. Bartram, Safer Water, Better Health Costs , Benefits and
337 Sustainability of Interventions To Protect and Promote Health, Geneva, 2008.
338 http://whqlibdoc.who.int/publications/2008/9789241596435_eng.pdf.
- 339 [12] Sab Miller, World Wildlife Fund, The Water - Food - Energy Nexus: Insights into resilient
340 development, 2014.

- 341 [13] L.C. Sima, M. Elimelech, More than a drop in the bucket: Decentralized membrane-based
342 drinking water refill stations in southeast Asia, *Environ. Sci. Technol.* 47 (2013) 7580–7588.
343 doi:10.1021/es304384n.
- 344 [14] J. Zhu, X.J. Fan, Y. Tao, D.Q. Wei, X.H. Zhang, Study on an integrated process combining
345 ozonation with ceramic ultra-filtration for decentralized supply of drinking water, *J. Environ.*
346 *Sci. Heal.* 49 (2014) 1296–1303. doi:10.1080/10934529.2014.91006.
- 347 [15] H. Huang, J.G. Jacangelo, K.J. Schwab, Decentralized Membrane Filtration System for
348 Sustainable and Safe Drinking Water Supply in Low-Income Countries: Baseline Study, *J.*
349 *Environ. Eng.* (2011) 981–989.
- 350 [16] B.P. Mbilinyi, S.D. Tumbo, H.F. Mahoo, E.M. Senkondo, N. Hatibu, Indigenous knowledge as
351 decision support tool in rainwater harvesting, *Phys. Chem. Earth, Parts A/B/C.* 30 (2005) 792–
352 798. doi:10.1016/j.pce.2005.08.022.
- 353 [17] L. Domènech, Rethinking water management: From centralised to decentralised water supply
354 and sanitation models, *Doc. d'Anàlisi Geogràfic.* 57 (2011) 293–310.
355 <http://dag.revista.uab.es/article/viewFile/v57-n2-domenech/pdf-en> (accessed January 14,
356 2016).
- 357 [18] A. Carratalà, A. Dionisio Calado, M.J. Mattle, R. Meierhofer, S. Luzi, T. Kohn, Solar Disinfection
358 of Viruses in Polyethylene Terephthalate Bottles, *Appl. Environ. Microbiol.* 82 (2016) 279–
359 288. doi:10.1128/AEM.02897-15.
- 360 [19] M. Attisani, Can solar technology generate clean water for developing nations?, *Renew.*
361 *Energy Focus.* 17 (2016) 138–139. doi:10.1016/j.ref.2016.07.003.
- 362 [20] S. Ali Baig, Q. Mahmood, B. Nawab, M. Nawaz Shafqat, A. Pervez, Improvement of drinking
363 water quality by using plant biomass through household biosand filter - A decentralized
364 approach, *Ecol. Eng.* 37 (2011) 1842–1848. doi:10.1016/j.ecoleng.2011.06.011.
- 365 [21] Q. Mahmood, S.A. Baig, B. Nawab, M.N. Shafqat, A. Pervez, B.S. Zeb, Development of low cost
366 household drinking water treatment system for the earthquake affected communities in
367 Northern Pakistan, *Desalination.* 273 (2011) 316–320. doi:10.1016/j.desal.2011.01.052.
- 368 [22] C. Chaidez, J.R. Ibarra-Rodríguez, J.B. Valdez-Torres, M. Soto, C.P. Gerba, N. Castro-del
369 Campo, Point-of-use Unit Based on Gravity Ultrafiltration Removes Waterborne
370 Gastrointestinal Pathogens from Untreated Water Sources in Rural Communities, *Wilderness*
371 *Environ. Med.* 27 (2016) 379–385. doi:10.1016/j.wem.2016.05.006.
- 372 [23] J. Långmark, M. V Storey, N.J. Ashbolt, T.-A. Stenström, Accumulation and fate of
373 microorganisms and microspheres in biofilms formed in a pilot-scale water distribution
374 system., *Appl. Environ. Microbiol.* 71 (2005) 706–12. doi:10.1128/AEM.71.2.706-712.2005.
- 375 [24] C.A. Martínez-Huitle, E. Brillas, Electrochemical Alternatives for Drinking Water Disinfection,
376 *Angew. Chemie Int. Ed.* 47 (2008) 1998–2005. doi:10.1002/anie.200703621.
- 377 [25] R.M.S. Thorn, S.W.H. Lee, G.M. Robinson, J. Greenman, D.M. Reynolds, Electrochemically
378 activated solutions: evidence for antimicrobial efficacy and applications in healthcare
379 environments., *Eur. J. Clin. Microbiol. Infect. Dis.* 31 (2012) 641–53. doi:10.1007/s10096-011-
380 1369-9.
- 381 [26] G. Robinson, R. Thorn, D. Reynolds, The effect of long-term storage on the physiochemical
382 and bactericidal properties of electrochemically activated solutions, *Int. J. Mol. Sci.* 14 (2013)

- 383 457–469.
- 384 [27] M.I. Gil, V.M. Gómez-López, Y.-C. Hung, A. Allende, Potential of Electrolyzed Water as an
385 Alternative Disinfectant Agent in the Fresh-Cut Industry, *Food Bioprocess Technol.* 8 (2015)
386 1336–1348. doi:10.1007/s11947-014-1444-1.
- 387 [28] M.A. Ashraf, S. Ullah, I. Ahmad, A.K. Qureshi, K.S. Balkhair, M. Abdur Rehman, Green biocides,
388 a promising technology: Current and future applications to industry and industrial processes,
389 *J. Sci. Food Agric.* 94 (2014) 388–403. doi:10.1002/jsfa.6371.
- 390 [29] S.M.E. Rahman, T. Ding, D.-H. Oh, Inactivation effect of newly developed low concentration
391 electrolyzed water and other sanitizers against microorganisms on spinach, *Food Control.* 21
392 (2010) 1383–1387.
- 393 [30] M.B. Rahman, T. Driscoll, C. Cowie, B.K. Armstrong, Disinfection by-products in drinking water
394 and colorectal cancer: A meta-analysis, *Int. J. Epidemiol.* 39 (2010) 733–745.
395 doi:10.1093/ije/dyp371.
- 396 [31] E.J. Park, E. Alexander, G. a. Taylor, R. Costa, D.H. Kang, Effects of organic matter on acidic
397 electrolysed water for reduction of foodborne pathogens on lettuce and spinach, *J. Appl.*
398 *Microbiol.* 105 (2008) 1802–1809. doi:10.1111/j.1365-2672.2008.03928.x.
- 399 [32] Y.W.Y.R. Huang, Y.C. Hung, S.Y. Hsu, Y.W.Y.R. Huang, D.F. Hwang, Application of electrolyzed
400 water in the food industry, *Food Control.* 19 (2008) 329–345.
401 doi:10.1016/j.foodcont.2007.08.012.
- 402 [33] V.M. Gómez-López, M.I. Gil, A. Allende, A novel electrochemical device as a disinfection
403 system to maintain water quality during washing of ready to eat fresh produce, *Food Control.*
404 (2016). doi:10.1016/j.foodcont.2016.07.001.
- 405 [34] A. Tomás-Callejas, G.B. Martínez-Hernández, F. Artés, F. Artés-Hernández, Neutral and acidic
406 electrolyzed water as emergent sanitizers for fresh-cut mizuna baby leaves, *Postharvest Biol.*
407 *Technol.* 59 (2011) 298–306. doi:10.1016/j.postharvbio.2010.09.013.
- 408 [35] J.B. Selkon, J.R. Babbt, R. Morris, Evaluation of the antimicrobial activity of a new super-
409 oxidized water, Sterilox[®], for the disinfection of endoscopes, *J. Hosp. Infect.* 41 (1999) 59–70.
410 doi:10.1016/S0195-6701(99)90038-5.
- 411 [36] K. Ghebremichael, E. Muchelemba, B. Petrusevski, G. Amy, Electrochemically activated water
412 as an alternative to chlorine for decentralized disinfection, in: *J. Water Supply Res. Technol. -*
413 *Aqua*, 2011: pp. 210–218. doi:10.2166/aqua.2011.034.
- 414 [37] C. Gonzalez, International: On-Site Mixed Oxidants Demonstrate Benefits in Puerto Rico,
415 *Water Cond. Purif.* 44 (2002) 62–65.
- 416 [38] L.B. Liao, W.M. Chen, X.M. Xiao, The generation and inactivation mechanism of oxidation–
417 reduction potential of electrolyzed oxidizing water, *J. Food Eng.* 78 (2007) 1326–1332.
418 doi:10.1016/j.jfoodeng.2006.01.004.
- 419 [39] G.M. Robinson, K.M. Tonks, R.M.S. Thorn, D.M. Reynolds, Application of Bacterial
420 Bioluminescence To Assess the Efficacy of Fast-Acting Biocides, *Antimicrob. Agents*
421 *Chemother.* 55 (2011) 5214–5219. doi:10.1128/AAC.00489-11.
- 422 [40] Drinking Water Directive, COUNCIL DIRECTIVE 98/83/EC, 1998.

- 423 [41] Drinking Water Inspectorate, The Water Supply (Water Quality) Regulations 2010, (2010).
424 <http://dwi.defra.gov.uk/stakeholders/legislation/wsr2010wales.pdf>.
- 425 [42] L.D. Renner, D.B. Weibel, Physicochemical regulation of biofilm formation, *MRS Bull.* 36
426 (2011) 347–355. doi:10.1557/mrs.2011.65.Physicochemical.
- 427 [43] R. Bernstein, V. Freger, J.-H. Lee, Y.-G. Kim, J. Lee, M. Herzberg, “Should I stay or should I go?”
428 Bacterial attachment vs biofilm formation on surface-modified membranes., *Biofouling.* 30
429 (2014) 367–76. doi:10.1080/08927014.2013.876011.
- 430 [44] M.S. Thantsha, T.E. Cloete, The effect of sodium chloride and sodium bicarbonate derived
431 anolytes, and anolyte-catholyte combination on biofilms, *Water South Africa.* 32 (2006) 237–
432 242.
- 433