

## КОМП'ЮТЕРНЕ МОДЕЛЮВАННЯ ПРИРОДООХОРОННИХ ПРОЦЕСІВ

## DESIGNING OF OPTIMAL AND FLEXIBLE TOTAL WATER NETWORKS

Poplewski G.<sup>1</sup>, Shakhnovsky A.<sup>2</sup>

## ПРОЕКТУВАННЯ ОПТИМАЛЬНИХ ГНУЧКИХ СХЕМ ВОДНОГО ГОСПОДАРСТВА

Поплєвські Г.<sup>1</sup>, Шахновський А. М.<sup>2</sup>

## ПРОЕКТИРОВАНИЕ ОПТИМАЛЬНЫХ ГИБКИХ СХЕМ ВОДНОГО ХОЗЯЙСТВА

Поплевски Г.<sup>1</sup>, Шахновский А. М.<sup>2</sup>

<sup>1</sup>Rzeszów University of Technology  
Rzeszów, Poland  
[ichgp@prz.edu.pl](mailto:ichgp@prz.edu.pl)

<sup>2</sup>National Technical University of Ukraine  
“Igor Sikorski Kyiv Polytechnical Institute”  
Kyiv, Ukraine  
[kxtp@kpi.ua](mailto:kxtp@kpi.ua)

*The paper presents the process water network cost optimization method. The purity and flow rate parameters for some processes change continuously and/or by leaps and bounds. The proposed design method takes into account these changes, so the obtained water network is prepared to work in such conditions (it is flexible). The flexible network design method was based on the theorem of corner points solutions.*

**Keywords:** flexible water networks, superstructure optimization, cost optimality

*У статті представлено метод оптимізації технологічних схем водного господарства, що базується на економічних критеріях. Ряд процесів водоспоживання характеризується безперервною і стрімкою зміною основних параметрів (зокрема, ступеню забрудненості та витрати води). Пропонований метод проектування враховує подібні зміни, внаслідок чого отримана схема водного господарства підготовлена до роботи в таких умовах (тобто, є гнучкою). В основі представленого методу гнучкого проектування схем водоспоживання лежать принципи адитивної комбінаторики, зокрема, теорема про кутові точки.*

**Ключові слова:** гнучкі схеми водного господарства, суперструктурна оптимізація, економічна ефективність

*В статье представлен базирующийся на экономических критериях метод оптимизации технологических схем водного хозяйства. Ряд процессов водопотребления характеризуются непрерывным и стремительным изменением основных параметров (в частности, степени загрязненности и расхода воды). Предлагаемый метод проектирования учитывает подобные изменения, вследствие чего полученная схема водного хозяйства подготовлена к работе в таких условиях (то есть, является гибкой). В основе представленного метода гибкого проектирования схем водопотребления лежат принципы аддитивной комбинаторики, в частности, теорема об угловых точках.*

**Ключевые слова:** гибкие схемы водного хозяйства, суперструктурная оптимизация, экономическая эффективность

## INTRODUCTION

Water is used in many branches of industry. Due to the growing price and diminishing natural resources, water should be saved. Limitation of water consumption can be achieved, for example, through reuse and regeneration. A review of optimization methods for the design of optimal water networks (WN) has been published in [1]. Unfortunately, WN that minimize fresh water consumption have a complex structure and also show no resistance to changes in process requirements for water parameters such as purity and flow rate. Non-optimal operation of the network or failure to meet new parameters results in the need for a costly break in production for modernization. Therefore, if it is possible to predict changes in parameter values, optimal and flexible process water networks (FWN) should be designed. This paper proposes FWN design method based on the theorem of corner solutions, which was first applied to the design of flexible heat exchanger networks [2].

## FORMULATION OF THE PROBLEM

The process water network consists of:

- fresh water source (FW) taken from the natural tank and treated to the level required by water using processes,
- sources of water - the source of water used one or more times. The water stream from sources is characterized by the flow rate and the concentration of pollutants,
- sinks of water - these processes have exact requirements regarding the required process water flow as well as the maximum concentration of pollutants,
- processes using water - the process consists of a connected sink and source. In the case of losses or water gains occurring in the process, the flow rate at the sink inlet may be different from the flow rate in the source stream of the respective process,
- regenerators - processes for partial or complete removal of all or some process water contaminants. It was assumed that the regenerator works without water loss, and the concentration of contaminants in the outlet stream does not depend on the concentration in the inlet stream,
- regenerators - processes for partial or complete removal of all or some process water contaminants. It was assumed that the regenerator works without water loss, and the concentration of contaminants in the outlet stream does not depend on the concentration in the inlet stream,
- water treatment - for this process, excess water is drained, which can not be re-used for technical or economic reasons. This water is treated and discharged into natural reservoirs.

Streams connecting the above network elements can be arbitrarily (except for cases forbidden eg by technology) branched as well as connected. As a result, it is possible to achieve optimal parameter values for individual streams, i.e. optimal water reuse is possible. This entails simultaneously minimizing the fresh water intake and minimizing the amount of treated wastewater.

It has been assumed that the values of some or all of the sink, sources and regenerators parameters may change. Parameter changes can be of various types:

1. Fluctuations around nominal value.
2. Periodic changes in production requirements - change the parameters of water streams from sources, as well as changing the requirements of recipients as to the quantity and quality of process water.

3. Periodic breaks in production resulting in the suspension of selected processes being sources and / or sinks.

The purpose of the optimization is to design the FWN:

- flexible (resistant to changes of water streams parameters and process requirements),
- optimal in terms of operating costs and the number of pipelines for all possible values of water network parameters and their combinations.

### PROBLEM SOLUTION

A mathematical method based on optimization of the superstructure was used to solve the problem. The superstructure has all possible for technical and economic reasons connections. The optimization of the mathematical model of the superstructure is aimed at determining the flow rate in individual pipelines. As a result, the structure of the optimal water network is also known. The mathematical model of the superstructure was described in detail in [3].

As mentioned in the introduction, the optimal water network designed for specific process parameters, in the case of periodic changes of these parameters or their fluctuation may work suboptimally, i.e. it may not be possible to achieve optimal operating parameters. Due to structure constraints and flow rate limits in pipelines, changing the parameters of water-using processes may even lead to expensive shutdown of production and modernization of the water network. Flexible water networks are resistant to such cases.

The method based on the theorem of corner solutions was used to solve the problem of FWN design. This theorem was first used to optimize flexible heat exchanger networks [2]. According to this theorem, a network that works optimally for all combinations of extreme parameter values (all corner points) will be able to work optimally also for different combinations of parameter values from the range determined by these extreme values. To design a flexible network, the following algorithm steps should be made:

1. For each corner point, calculate as many optimal structures as possible.
2. For each corner point, choose one solution and overlap their structures to each other.
3. Determine the variation intervals of the flow rate for all pipelines.

Re. 1. In order to obtain the optimal FWN in point 2 of the algorithm, it is necessary to have as many as possible (preferably all) optimal WNs for all corner points. WNs is obtained by multiple solution of the model. To generate a different WNs (in terms of structure), after each run the integer cut type condition is inserted into the model.

Re. 2. In order for FWN to fulfill the theorem of corner solutions, the pipeline structure should contain one WN for each corner point. In the second stage of the FWN design, the main goal is to choose the WNs that are overlapped so that the final FWN has as simple as possible structure (with the least number of connections) which minimizes the investment costs of network construction and makes easier control. The overlapping component WNs is a very complex IP combinatorial problem and therefore it was solved using optimization methods. The optimization model has been described in detail in [3].

Re. 3. This step allows you to specify, in addition to the FWN structure, also the flow rate intervals for changing network operation parameters. This information is needed for the correct selection of pipe diameters, pump performance and other additional piping equipment. It also gives the possibility of initial orientation regarding the optimal FWN control. This step of the method algorithm has been described in [3].

All the above mentioned calculations were carried out in the GAMS program.

**EXAMPLE**

Given the set of fresh water sources, 5 sources of used water and 1 source of regenerated water. In addition, a set of water sinks is given: 6 sinks of water, regenerator and wastewater treatment process. All parameters are given in Table 1.

Table 1. Parameters of sources and sinks

<b>SOURCES</b> <b>(i)</b>	Fresh water	source 1	source 2	source 3	source 4	source 5	regenerator	
$C_j$ [ppm]	0	100	140	180	230	250	<30,45>	
$F_j$ [t/h]	boundless	{0, 50}	60	70	80	195	equal to the inlet	
<b>SINKS</b> <b>(j)</b>	treatment	sink 1	sink 2	sink 3	sink 4	sink 5	sink 6	regenerator
$C_i^{max}$ [ppm]	boundless	0	50	50	140	170	240	boundless
$F_i$ [t/h]	boundless	{0, 50}	60	80	70	80	195	boundless

It should be noted that in the case of sources, the concentration of contaminants and the flow rate are determined. The situation is different for the sinks for whom the maximum permissible value of the contamination concentration of the process water stream is specified. The mathematical model of the superstructure for such a problem was presented in [3]. It should be noted that the model is also valid for more than one number of contaminants.

Most of the water parameters in the Table 1 are fixed. It was assumed that the 1<sup>st</sup> process consisting of 1<sup>st</sup> sink and 1<sup>st</sup> source is periodically activated. Therefore, in the Table 1 the flow rate for 1<sup>st</sup> source and 1<sup>st</sup> sink has two values of 0 and 50 t/h. These are therefore abrupt changes of the parameter value.

The second process that shows changes in parameters is the regeneration process. In this case, the concentration of the contaminant in the outlet stream changes. This concentration may vary within the range given in Table 1.

The water network for a given set of parameters is optimal when it reaches the minimum of the objective function (1).

$$OF = Min \left( \alpha \sum_j F_{FW,j} + \beta \sum_i F_{i,FT} + \gamma \sum_i \sum_R F_{i,R} + \delta \sum_R F_{R,FT} \right) \quad (1)$$

where:

- $i, j$  - sources, sinks;
- $FW$  - source of fresh water;
- $R$  - inlet to the regenerator;
- $FT$  - inlet to the final treatment.

The values of the coefficients in the eq. (1) are given in Table 2.

Table 2. Cost coefficients of process water streams in [\$/t]

$\alpha$ -fresh water	$\beta$ -treatment	$\gamma$ -regeneration	$\delta$ -treatment after regeneration
1.00	0.65	0.15	0.35

**PROBLEM SOLUTION AND RESULTS**

In order to solve the problem of the method based on corner points theorem it must first define all possible combinations of extreme parameter values. These combinations are corner points. Table 3 contains the values for the sink 1, source 1 and regenerator parameters for all corner points.

Table 3. Corner points.

		corner point 1	corner point 2	corner point 3	corner point 4
source 1	$F_I$ [t/h]	50	50	0	0
sink 1	$F_I$ [t/h]	50	50	0	0
regenerator	$C$ [ppm]	30	45	30	45

The second step is to generate for each corner point all WNs that have the minimum value of the objective function (1) for the given data set and the smallest number of pipelines in its structure. Using the method of generating many, new solutions with integer cut conditions [3], many solutions were obtained. Short statistics are listed in Table 4.

Table 4. Shortened statistics of obtained solutions

	corner point 1	corner point 2	corner point 3	corner point 4
Value of the objective function	91.0	91.7	87.5	88.1
Number of pipelines	14	14	14	13
Number of received WNs	4	7	7	1

The next step is to choose one WN for each corner point and overlap these selected structures. The selection of WNs should ensure the minimum number of pipelines in the final FWN. Even for a small number of corner points, the number of combinations it is very large and is growing rapidly with the increase of the problem scale. Therefore, a mathematical method for optimizing the choice of solutions has been developed, which is imposed in order to obtain a FWN. This method is described in detail in [3]. As a result of this method to the construction of FWN were selected WNs shown in Figure 1.

As shown, the final treatment process is not used for any corner point. This does not mean, that the treatment process is unnecessary. It treats wastewater from sources existing in the plant, but not included in this task.

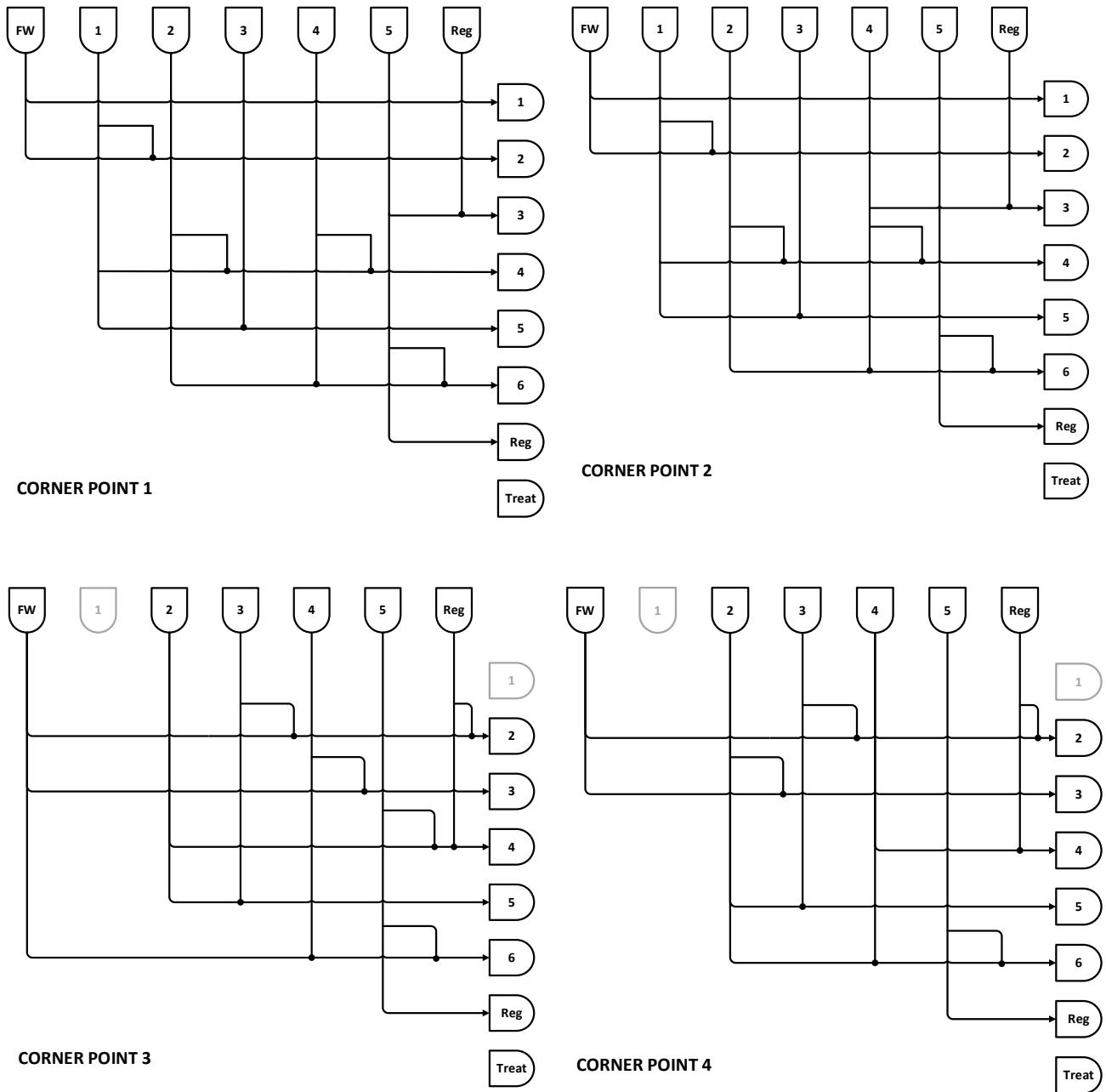

Fig. 1. Chosen water networks for all corner points

As a result of the superimposition of WNs from Fig. 1, a final FWN structure with 23 pipelines was obtained (Fig. 2). The dotted lines are those pipelines and processes that are used only for certain sets of parameters. In Fig. 2, only 5 pipelines that are always used are marked with a continuous line. This does not mean that for each set of parameter values, the flow rates in individual pipelines are constant. In the case of fluctuations in the purity of regenerated water, they change continuously, while in the case of shutting down the 1<sup>st</sup> process, these changes are of a stepwise nature. For example, the flow rate of fresh water supplied to the 3<sup>rd</sup> sink ranges from 51.4 t/h to 62.6 t/h. This pipeline is turned off (it is unnecessary) when the 1<sup>st</sup> process works. The method of determining the flow rate in pipelines is described in detail in [3].

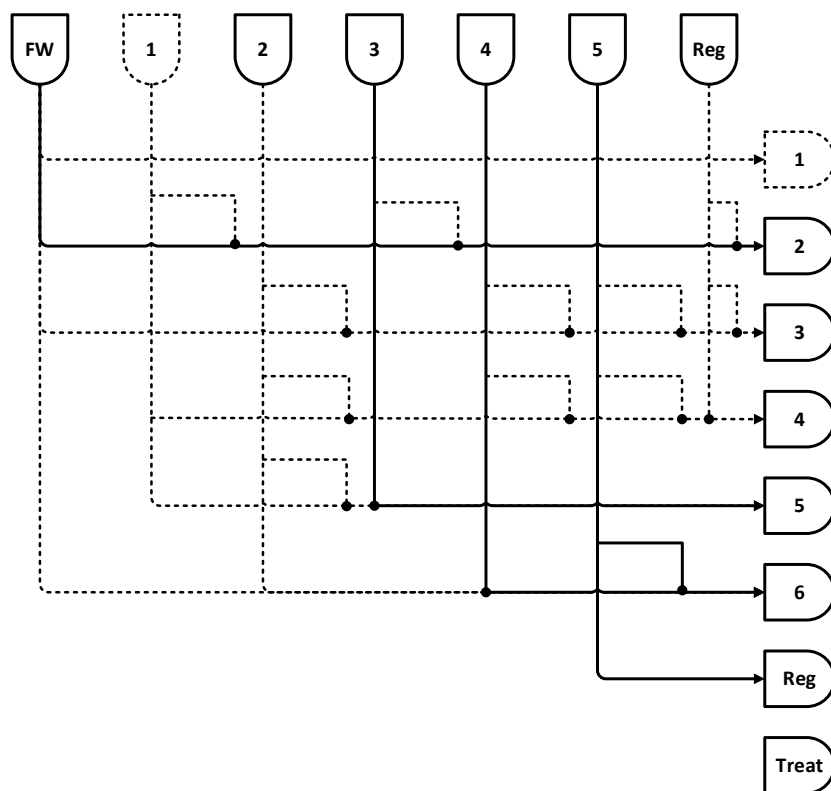

Fig. 2. Structure of the final FWN

## CONCLUSIONS

The paper presents the method of designing optimal and flexible water networks. The method is based on the theory of corner solutions. The method is a multi-step, each step being solved with the mathematical optimization.

This paper presents an example of the application the FWN design method in the case of continuous and step fluctuations both in the flow rate and in the concentration of contaminants. In addition, it takes into account the cost objective function. The obtained result confirmed great possibilities of solving various problems of optimization of flexible process water networks. An additional possibility of determining not only the structure of the network but also the water flow rates in individual pipelines is crucial for the proper design of the flexible network.

## REFERENCES

1. Jeżowski J. Review of water network design methods with literature annotations. *Ind. Eng. Chem. Res.*, 2010, 49, 4475–4516.
2. Saboo A. K., Morari M. Design of resilient processing plants. *IV. Some new results on heat exchanger network synthesis*, *Chem. Eng. Sci.*, 1984, 39 (3), 579-592.
3. Poplewski G. A new methodology for the synthesis of an optimum flexible water networks. *Process Saf. Environ. Prot.*, 2015, 95, 172–183.