



**UCC Library and UCC researchers have made this item openly available.
Please [let us know](#) how this has helped you. Thanks!**

Title	Harsh environments minimally invasive optical sensing technique for extreme temperatures: 1000 degrees C and approaching 2500 degrees C
Author(s)	Riza, Nabeel A.; Arain, Muzamil; Perez, Frank
Publication date	2005-05-23
Original citation	Riza, N. A., Arain, M. and Perez, F. (2005) 'Harsh environments minimally invasive optical sensing technique for extreme temperatures: 1000 degrees C and approaching 2500 degrees C', Proceedings of SPIE, 5855, 17th International Conference on Optical Fibre Sensors, Bruges, Belgium, 23 May, pp. 687-690. doi: 10.1117/12.623399
Type of publication	Conference item
Link to publisher's version	http://dx.doi.org/10.1117/12.623399 Access to the full text of the published version may require a subscription.
Rights	© 2005 Society of Photo-Optical Instrumentation Engineers (SPIE). One print or electronic copy may be made for personal use only. Systematic reproduction and distribution, duplication of any material in this paper for a fee or for commercial purposes, or modification of the content of the paper are prohibited.
Item downloaded from	http://hdl.handle.net/10468/10068

Downloaded on 2020-06-06T01:36:54Z

PROCEEDINGS OF SPIE

SPIDigitalLibrary.org/conference-proceedings-of-spie

Harsh environments minimally invasive optical sensing technique for extreme temperatures: 1000 degrees C and approaching 2500 degrees C

Riza, Nabeel, Arain, Muzamil, Perez, Frank

Nabeel Agha Riza, Muzamil Arain, Frank Perez, "Harsh environments minimally invasive optical sensing technique for extreme temperatures: 1000 degrees C and approaching 2500 degrees C," Proc. SPIE 5855, 17th International Conference on Optical Fibre Sensors, (23 May 2005); doi: 10.1117/12.623399

SPIE.

Event: 17th International Conference on Optical Fibre Sensors, 2005, Bruges, Belgium

Harsh Environments Minimally Invasive Optical Sensing Technique for Extreme Temperatures: 1000 °C and Approaching 2500 °C

Nabeel A. Riza, Muzzamil Arain*, and Frank Perez

Nuonics, Inc., 1025 S. Semoran Blvd., Suite 1093, Winter Park, FL 32792, USA.

* College of Optics/CREOL, Univ. Central Florida, Box 162700, Orlando, FL 32816, USA

ABSTRACT

To the best of our knowledge, for the first time is designed and demonstrated a single crystal Silicon Carbide (SiC)-based minimally invasive smart optical sensor suited for harsh environments and temperatures reaching 2500 °C. The novel sensor design is based on an agile wavelength source, instantaneous single wavelength interferometry, full optical power cycle data acquisition, free-space targeted laser beam, multiple single crystal thick SiC optical frontend chips, and multi-wavelength signal processing for unambiguous temperature measurements to form a fast and distributed smart optical sensor system. Experiments conducted using a 1550 nm eye safe band tunable laser and a 300 micron coating-free thick SiC chip demonstrate temperature sensing from room temperature to 1000 °C with a measured 1.3 °C resolution. Applications for the proposed sensor include use in fossil fuel-based power systems, aerospace/aircraft systems, satellite systems, deep space exploration systems, and drilling and oil mining industries.

Keywords: High Temperature Sensor, Harsh Environment, Optical Sensor, Silicon Carbide.

1. INTRODUCTION

Over the years, researchers have turned to optics for providing a robust high temperature sensing solution in hazardous environments. The focus has been mainly directed in two themes. The first theme involves using the optical fiber as both the light delivery and reception mechanism and the temperature sensing mechanism. Specifically, a Fiber Bragg Grating (FBG) present within the core of the single mode fiber (SMF) acts as a temperature sensor. Here, a broadband light source is fed to the sensor and the spectral shift of the FBG reflected light is used to determine the temperature value. Today, FBG sensors are written using Ultra-Violet (UV) exposure in silica fibers. Such FBG sensors are typically limited to under 1000°C because of the instability of the FBG structure at higher temperatures.¹ To practically reach the higher temperatures (e.g., 1600°C) for fossil fuel applications, single crystal Sapphire fiber has been used for Fabry-Perot cavity² and FBG formation.³ The single crystal Sapphire fiber FBG has a very large diameter (e.g., 150 microns)³ that introduces multi-mode light propagation noise that limits sensor performance. An alternate approach proposed replaced the Sapphire fiber frontend sensing element with a complex assembly of individual components that include a Sapphire bulk crystal that forms a temperature dependent birefringent Fabry-Perot cavity, a single crystal cubic zirconia light reflecting prism, a Glan-Thompson polarizer, a single crystal Sapphire assembly tube, a fiber collimation lens, a ceramic extension tube, and seven 200 micron diameter multimode optical fibers.⁴ Hence this proposed sensor frontend sensing element not only has low optical efficiency and high noise generation issues due to its multi-mode versus SMF design, the sensor frontend is limited by the lowest high temperature performance of a given component in the assembly and not just by the Sapphire crystal and zirconia high temperature ability. Add to these issues, the polarization and component alignment sensitivity of the entire frontend sensor assembly.

It has long been recognized that SiC is an excellent high temperature material. Prior works include using thin films of SiC grown on substrates such as Sapphire and Silicon to act as Fabry Perot Etalons to form high temperature fiber-optic sensors.⁵⁻⁶ Although SiC thin films on high temperature substrates such as Sapphire can operate at high temperatures, the SiC and Sapphire interface have different material properties such as thermal coefficient of expansion and refractive indices. In particular, high temperature gradients and fast temperature/pressure temporal effects can cause stress fields at the SiC thin film-Sapphire interface causing deterioration of optical properties required to form a quality Fabry-Perot etalon required for sensing based on SiC film refractive index change. Note that these previous works also had a limitation on the measured unambiguous sensing (e.g., temperature) range dictated only by the SiC thin film etalon design, i.e., film thickness and reflective interface refractive indices/reflectivities. Thus making a thinner SiC film would provide smaller optical path length

changes due to temperature and hence increase the unambiguous temperature range. But making a thinner SiC film makes the sensor less sensitive and more fragile to pressure. Hence, a dilemma exists. In addition, temperature change is preferably estimated based on tracking optical spectrum minima shifts using precision optical spectrum analysis optics, making precise temperature estimation a challenge dependent on the precision (wavelength resolution) of the optical spectrum analysis hardware. In addition, better temperature detection sensitivity is achieved using thicker films, but thicker etalon gives narrower spacing between adjacent spectral minima. Thicker films are harder to grow with uniform thicknesses and then one requires higher resolution for the optical spectrum analysis optics. Hence there exists a dilemma where a thick film is desired for better sensing resolution but it requires a better precision optical spectrum analyzer (OSA) and of course thicker thin film SiC etalons are harder to make optically flat.

Ideally, one would like a robust optical sensor that can be remoted, is minimally invasive, works at high temperatures (e.g., 2000 °C) and pressures including chemically corrosive environments, requires low cost low loss optics, has high sensing resolution over any extended wide unambiguous range, and provides easy access to many sensing points. In this paper, to the best of our knowledge, we propose such a novel sensor.

2. MINIMALLY INVASIVE OPTICAL SENSOR DESIGN

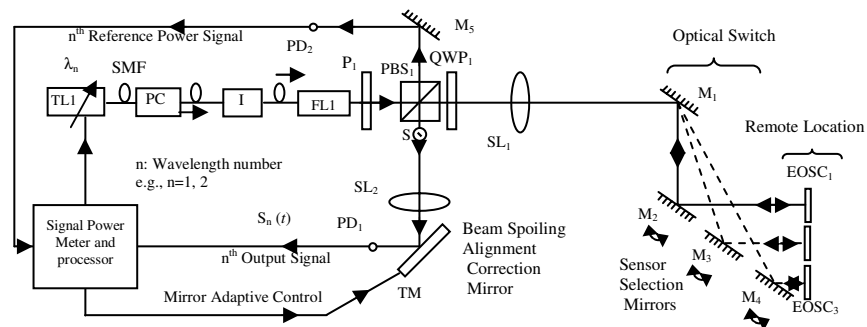

Fig.1 Proposed high temperature minimally invasive optical sensor system.

Fig.1 shows the proposed high temperature minimally invasive optical sensor. The sample frontend is composed for example of three Etalon Optical Sensor Chips (EOSCs) using single crystal SiC. Light from a tunable laser passes via fiber-optics such as a polarization controller (PC) and isolator (I) to exit via a fiber lens (FL₁) to produce a freespace beam. This light then passes via a polarizer P₁ and a polarizing beam splitter PBS₁ to produce a reflected beam that via mirror M₅ enters photodetector PD₂ whose output is used to access sensor efficiency. The straight linearly (or horizontally) polarized beam from PBS₁ passes via a quarter-wave plate QWP₁ (or 45° power Faraday rotator) and a bulk spherical lens SL₁. The use of QWP₁ gives polarization insensitivity to the SiC sensing operations while lenses reduce beam spreading loss. The mirrors M₁, M₂, M₃, M₄ are 2-axis mirrors that are adjusted to select the desired EOSC and implement normal incidence alignment with the etalon chip. The single crystal SiC chip acts as a natural etalon in air. Light reflected from the chosen etalon chip traces the path back via the mirrors and SL₁ to reflect via PBS₁ as vertically polarized light towards spherical lens SL₂. The returning light via SL₂ then passes via the beamforming mirror TM to strike a freespace coupled photodetector PD₁. TM is a beam spoiling correction mirror such as a deformable mirror that as needed corrects wavefront distortions and keeps the returning beam aligned on PD₁ to produce the optimal sensing signal based on OPL changes in the frontend etalon chip. Because the EOSCs can be mounted on various platforms that may have vibrations or other beam perturbing environmental effects such as air currents, pressure gradients, thermal gradients, the returning freespace beam from the sensing zone can suffer unwanted beam motions and wavefront distortions. Hence, for proper sensor operation, the returning beam must strike the active detection zone of the freespace large area point photodetector. Note that as the etalon OPL changes due to some effect such as change in temperature, the reflected signal power varies and can undergo several power variation cycles. To maintain proper sensor operation and calibration, the instantaneous PD₁ produced power level signal is normalized before signal processing. This normalization is done by sweeping the laser wavelength to measure the nearest power maximum and minimum and using these max/min data for the instantaneous reading normalization, hence giving robustness to the sensor operations.

For a single crystal SiC etalon, one fundamentally has the air-SiC interfaces acting as the two 20% reflectivity mirrors of an etalon cavity. Thus the optical power detected as an electrical signal from PD1 is given by $i(t) = C \{2R(1 + \cos(OPL)) / \{1 + 2R(1 + \cos(OPL))\}\}$, where C is a scaling constant depending on various factors including alignment conditions. R is the air-SiC interface Fresnel reflectivity power. Optical path length $OPL = \{4\pi/\lambda\} \{n d\}$, where λ is the tunable laser wavelength, d is the SiC crystal thickness, and n is the SiC material refractive index. In the proposed sensor, for each power reading taken, C is determined for normalizing the $\cos(OPL)$ data between -1 and 1. This normalization process involves tuning the laser to find the nearest maximum and minimum PD₁ power levels, and then using these max/min powers to normalize the instantaneous power data at the predesigned wavelength. The refractive index of SiC is temperature (T) dependent. Thus as T changes over a range of T_{\min} to T_{\max} , the SiC OPL changes modulo- 2π giving maximum to minimum periodic variations of the measured photo-current $i(t)$ and hence also the calculated $\cos(OPL)$. For a chosen λ_1 and a temperature range variation from T_{\min} to T_{\max} , the OPL change can be written as: $\Delta OPL = \{4\pi/\lambda_1\} \{n(\lambda_1, T_{\max}) d(T_{\max}) - n(\lambda_1, T_{\min}) d(T_{\min})\} = 2\pi N_1$, where this cosine function goes through N_1 full 2π cycles. Next another wavelength λ_2 is chosen such that for the given fixed parameters of the EOSC and the same chosen temperature range T_{\min} to T_{\max} , the OPL change over this temperature range is given as $\Delta OPL(T) = \{4\pi/\lambda_1\} \{n(\lambda_2, T_{\max}) d(T_{\max}) - n(\lambda_2, T_{\min}) d(T_{\min})\} = 2\pi N_1 + \pi$, indicating that at the λ_2 wavelength, OPL change includes an additional π phase shift. When using these periodic data functions, this additional π phase shift is the key condition to generate unambiguous temperature data over a wide temperature range. Hence, after choosing a certain λ_1 and taking photodetector measurements that then give the $\cos(OPL)$ function with the OPL change parameter (e.g., temperature), one must choose another measurement wavelength λ_2 by the derived expression $\lambda_2 = \{\lambda_1\} [N_1 / \{N_1 + 1\}]$. By comparing the OPL difference at the two wavelengths and one of the OPL data (e.g., at λ_1), a unique unambiguous temperature reading can be ascertained. Thus, once the proposed sensor using a given SiC chip has been calibrated for the designed temperature range, instantaneous power data taken by the sensor can be quickly compared with a computer stored table to determine the actual measured temperature. The key data taken by this sensor while in the operational mode are PD₁ power readings at λ_1 and λ_2 and their related nearest optical power max/min values to normalize the data. Because today's commercial tunable lasers can be reset quickly (e.g., 1 ms) and accurately (e.g., within 0.01 nm), the proposed sensor can quickly provide the desired sensing parameter, e.g., temperature.

3. EXPERIMENTS

A 6H-SiC single crystal of 300 micron thickness is used with a 1500-1600 nm tunable laser to demonstrate the principles of the proposed sensor using λ_1 of 1547 nm and λ_2 of 1530 nm. The SiC chip is heated via a custom induction heater to temperatures exceeding 1000°C. Data is taken with computer controlled optical power meter and

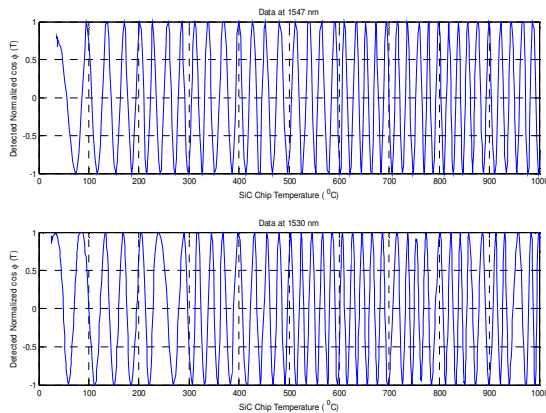

Fig. 2. Sensor provided normalized $\cos\{\phi(T)\}$ measurements at 1530 nm and 1547 nm as the SiC chip temperature is raised to 1000°C.

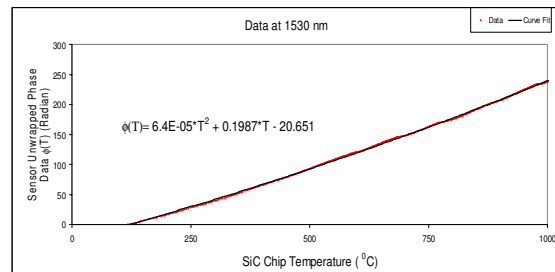

Fig. 3. Sensor Unwrapped Phase Data $\phi(T)$ in Radians versus SiC Chip Temperature ($^{\circ}\text{C}$) with data taken at 1530 nm. A weak quadratic curve fit is achieved for this data.

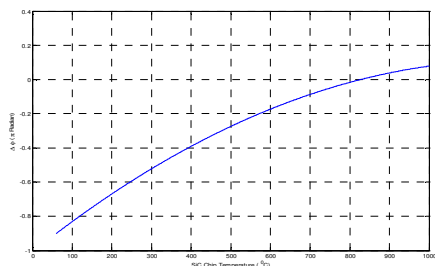

Fig. 4. Phase Difference $\Delta\phi(T)$ Data for the two wavelengths used for the sensor operations.

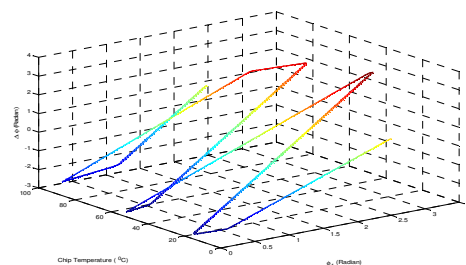

Fig. 5: 3-D representation of the sensor calibration chart for the unambiguous temperature measurement of temperature from room conditions to 100⁰C.

SiC chip reference temperature is measured using a thermocouple. Once the raw optical power data is collected for both wavelengths over the room temperature to 1000⁰C range, a computer uses the data to get the normalized $\cos(OPL)$ function (see Fig.2) for the sensor at the two chosen wavelengths. Because the power cycles can be counted from Fig.2, the OPL data can be unwrapped in radians and is shown in Fig.3 for λ_2 data. Similarly, unwrapped OPL data is produced for λ_1 data. Using these unwrapped data sets, the OPL difference plot Fig.4 is generated. Fig.4 when used with one of the phase data sets determines temperature in an unambiguous manner (see for example Fig.5 for a zoomed room temperature to 100⁰C range).

4. CONCLUSION

Proposed and demonstrated to 1000⁰C is a novel high temperature sensor using tunable light, free-space beam targeted single crystal SiC chip frontends, and robust multi-wavelength signal processing concepts to simultaneously provide both high resolution and wide unambiguous range sensing for dynamic scenarios. Unlike previous wavelength sensitive sensors (e.g., FBG & etalon), the proposed sensor design is not dependent on OSA resolution. Because temperature assessment is based upon monitoring optical power data over full min/max cycles and not just locating and tracking minima or maxima (as in traditional FBG and etalon-based sensors), a better sensor resolution can be achieved particularly when the etalon optical spectral filter function peaks/nulls shape change as R changes based on conditions in the dynamic sensing zone. The sensor relies on instantaneous single wavelength interferometry, thus eliminating inter-wavelength crosstalk issues. The sensor can also produce traditional broadband spectral power sensing data using laser tuning. The sensor has an operating potential temperature near 2500⁰C, the melting point for single crystal SiC. Future works will report the detailed theory, engineering, and experiments of this novel sensor.

ACKNOWLEDGMENTS

This research is supported by a U.S. Department of Energy Grant to Nuonics, Inc. Support on the high temperature test chamber is provided by Applicote Assoc. (Dr. N. Quick) and CREOL-UCF (Dr. A. Kar).

REFERENCES

1. M. Winz, et.al, "High temperature stable fiber Bragg gratings," OFS Conf. Digest, pp.195-198, 2002.
2. H. Xiao, et.al., "Absolute Sapphire optical fiber sensor for high temperature applications," SPIE Proc. 3201, pp.36-42, 1998.
3. D. Grobnc, et.al., "Ultra high temperature FBG sensor made in Sapphire fiber using Isothermal using femtosecond laser radiation," ECOC 2004 Proc. Vol.2, pp.128-129, Stockholm, Sep7, 2004.
4. Y. Zhang, et.al., "Single-crystal sapphire-based optical high temperature sensor for harsh environments," *Opt. Eng.*, **43**, 157-164, 2004.
5. G. Beheim, "Fibre-optic thermometer using semiconductor-etalon sensor," *Elect. Lett.*, **22**, 238, 239, 1986.
6. L. Cheng, et.al., "SiC thin film Fabry-Perot interferometer for fiber-optic temperature sensor," *IEEE Tran. Electron Devices*, **50**, 10, pp. 2159-2164, Oct. 2003.