

Geometric and algebraic classification of quadratic differential systems with invariant hyperbolas

Regilene D. S. Oliveira

Instituto de Ciências Matemáticas e de Computação
Universidade de São Paulo (regilene@icmc.usp.br)

Alex C. Rezende

Departament de Matemàtiques
Universitat Autònoma de Barcelona (alexcrezende@gmail.com)

Dana Schlomiuk

Département de Mathématiques et de Statistiques
Université de Montréal (dasch@dms.umontreal.ca)

Nicolae Vulpe

Institute of Mathematics and Computer Science
Academy of Sciences of Moldova (nvulpe@gmail.com)

Abstract

Let **QSH** be the whole class of non-degenerate planar quadratic differential systems possessing at least one invariant hyperbola. We classify this family of systems, modulo the action of the group of real affine transformations and time rescaling, according to their geometric properties encoded in the configurations of invariant hyperbolas and invariant straight lines which these systems possess. The classification is given both in terms of algebraic geometric invariants and also in terms of affine invariant polynomials and it yields a total of 205 distinct such configurations. We have 162 configurations for the subclass **QSH**_($\eta > 0$) of systems which possess three distinct real singularities at infinity, and 43 configurations for the subclass **QSH**_($\eta = 0$) of systems which possess either exactly two distinct real singularities at infinity or the line at infinity filled up with singularities. The algebraic classification, based on the invariant polynomials, is also an algorithm which makes it possible to verify for any given real quadratic differential system if it has invariant hyperbolas or not and to specify its configuration of invariant hyperbolas and straight lines.

Key-words: quadratic differential systems, algebraic solution, configuration of algebraic solutions, affine invariant polynomials, group action

2000 Mathematics Subject Classification: 34C23, 34A34

1 Introduction and statement of the main results

We consider planar polynomial differential systems which are systems of the form

$$dx/dt = p(x, y), \quad dy/dt = q(x, y) \tag{1}$$

where $p(x, y), q(x, y)$ are polynomial in x, y with real coefficients ($p, q \in \mathbb{R}[x, y]$) and their associated vector fields

$$X = p(x, y) \frac{\partial}{\partial x} + q(x, y) \frac{\partial}{\partial y}. \quad (2)$$

We call *degree* of such a system the number $\max(\deg(p), \deg(q))$. In the case where the polynomials p and q are coprime we say that (1) is *non-degenerate*.

A real quadratic differential system is a polynomial differential system of degree 2, i.e.

$$\begin{aligned} dx/dt &= p_0 + p_1(\tilde{a}, x, y) + p_2(\tilde{a}, x, y) \equiv p(\tilde{a}, x, y), \\ dy/dt &= q_0 + q_1(\tilde{a}, x, y) + q_2(\tilde{a}, x, y) \equiv q(\tilde{a}, x, y) \end{aligned} \quad (3)$$

with $\max(\deg(p), \deg(q)) = 2$ and

$$\begin{aligned} p_0 &= a, & p_1(\tilde{a}, x, y) &= cx + dy, & p_2(\tilde{a}, x, y) &= gx^2 + 2hxy + ky^2, \\ q_0 &= b, & q_1(\tilde{a}, x, y) &= ex + fy, & q_2(\tilde{a}, x, y) &= lx^2 + 2mxy + ny^2. \end{aligned}$$

Here we denote by $\tilde{a} = (a, b, c, d, e, f, g, h, k, l, m, n)$ the 12-tuple of the coefficients of system (3). Thus a quadratic system can be identified with a points \tilde{a} in \mathbb{R}^{12} .

We denote the class of all quadratic differential systems with **QS**.

Planar polynomial differential systems occur very often in various branches of applied mathematics, in modeling natural phenomena, for example, modeling the time evolution of conflicting species in biology and in chemical reactions and economics [14, 32], in astrophysics [6], in the equations of continuity describing the interactions of ions, electrons and neutral species in plasma physics [21]. Polynomial systems appear also in shock waves, in neural networks, etc. Such differential systems have also theoretical importance. Several problems on polynomial differential systems, which were stated more than one hundred years ago, are still open: the second part of Hilbert's 16th problem stated by Hilbert in 1900 [10], the problem of algebraic integrability stated by Poincaré in 1891 [19], [20], the problem of the center stated by Poincaré in 1885 [18], and problems on integrability resulting from the work of Darboux [8] published in 1878. With the exception of the problem of the center, which was solved only for quadratic differential systems, all the other problems mentioned above, are still unsolved even in the quadratic case.

Definition 1 (Darboux). *An algebraic curve $f(x, y) = 0$ where $f \in \mathbb{C}[x, y]$ is an invariant curve of the planar polynomial system (1) if and only if there exists a polynomial $k(x, y) \in \mathbb{C}[x, y]$ such that*

$$p(x, y) \frac{\partial f}{\partial x} + q(x, y) \frac{\partial f}{\partial y} = f(x, y)k(x, y).$$

Definition 2 (Darboux). *We call algebraic solution of a planar polynomial system an invariant algebraic curve over \mathbb{C} which is irreducible.*

One of our motivations in this article comes from integrability problems related to the work of Darboux [8].

Theorem 1 (Darboux). *Suppose that a polynomial system (1) has m invariant algebraic curves $f_i(x, y) = 0$, $i \leq m$, with $f_i \in \mathbb{C}[x, y]$ and with $m > n(n + 1)/2$ where n is the degree of the system. Then there exist complex numbers $\lambda_1, \dots, \lambda_m$ such that $f_1^{\lambda_1} \dots f_m^{\lambda_m}$ is a first integral of the system.*

The condition in Darboux's theorem is only sufficient for Darboux integrability (integrability in terms of invariant algebraic curves) and it is not also necessary. Thus the lower bound on the number of invariant curves sufficient for Darboux integrability stated in the theorem of Darboux is larger than necessary. Darboux' theory has been improved by including for example the multiplicity of the curves ([13]). Also, the number of invariant algebraic curves needed was reduced but by adding some conditions, in particular the condition that any two of the curves be transversal. But a deeper understanding about Darboux integrability is still lacking. Algebraic integrability, which intervenes in the open problem stated by Poincaré in 1891 ([19] and [20]), and which means the existence of a rational first integral for the system, is a particular case of Darboux integrability.

Theorem 2 (Jouanolou [11]). *Suppose that a polynomial system (1), defined by polynomials $p(x, y)$, $q(x, y) \in \mathbb{C}[x, y]$, has m invariant algebraic curves $f_i(x, y) = 0$, $i \leq m$, with $f_i \in \mathbb{C}[x, y]$ and with $m \geq n(n+1)/2 + 2$ where n is the degree of the system. Then the system has a rational first integral $h(x, y)/g(x, y)$ where $h(x, y), g(x, y) \in \mathbb{C}[x, y]$.*

To advance knowledge on algebraic or more generally Darboux integrability it is necessary to have a large number of examples to analyze. In the literature, scattered isolated examples were analyzed but a more systematic approach was still needed. Schlomiuk and Vulpe initiated a systematic program to construct such a data base for quadratic differential systems. Since the simplest case is of systems with invariant straight lines, their first works involved only invariant lines for quadratic systems (see [24], [26], [27], [29], [30]). In this work we study a class of quadratic systems with invariant conics, namely the class **QSH** of non-degenerate (i.e. p, q are relatively prime) quadratic differential systems having an invariant hyperbola. Such systems could also have some invariant lines and in many cases the presence of these invariant curves turns them into Darboux integrable systems. We always assume here that the systems (3) are non-degenerate because otherwise doing a time rescaling, they can be reduced to linear or constant systems. Under this assumption all the systems in **QSH** have a finite number of finite singular points.

The irreducible real affine conics are the hyperbolas, ellipses and parabolas. One way to distinguish them is consider their points at infinity (see [1]). The term hyperbola is used for a real irreducible affine conic which has two real points at infinity. This distinguishes it from the other two irreducible real conics: the parabola has just one real point at infinity which is double and the ellipse has two complex points at infinity.

In the theory of Darboux the invariant algebraic curves are considered (and rightly so) over the complex field \mathbb{C} . We may extend the notion of hyperbola (parabola or ellipse) for conics over \mathbb{C} . A hyperbola (respectively parabola or ellipse) is an algebraic curve $C : f(x, y) = 0$ with $f \in \mathbb{C}[x, y]$, $\deg(f) = 2$ which is irreducible and which has two real points at infinity (respectively one double real point at infinity or two complex (non-real) points at infinity). We point out that if we have a curve $C : f(x, y) = 0$ over \mathbb{C} it could happen that multiplying the equation by a number $\lambda \in \mathbb{C}^* = \mathbb{C} \setminus \{0\}$, the coefficients of the new equation become real. In this paper by a complex hyperbola (respectively line) we mean an irreducible conic (respectively line) whose coefficients cannot be made real by the multiplication with a non-zero complex constant and whose points at infinity are real and distinct. We have real quadratic differential systems having complex invariant hyperbolas (respectively complex invariant lines).

Let us suppose that a polynomial differential system has an algebraic solution $f(x, y) = 0$ where

$f(x, y) \in \mathbb{C}[x, y]$ is of degree n , $f(x, y) = a_0 + a_{10}x + a_{01}y + \dots + a_{n0}x^n + a_{n-1,1}x^{n-1}y + \dots + a_{0n}y^n$ with $\hat{a} = (a_0, \dots, a_{0n}) \in \mathbb{C}^N$ where $N = (n+1)(n+2)/2$. We note that the equation $\lambda f(x, y) = 0$ where $\lambda \in \mathbb{C}^* = \mathbb{C} \setminus \{0\}$ yields the same locus of complex points in the plane as the locus induced by $f(x, y) = 0$. So, a curve of degree n defined by \hat{a} can be identified with a point $[\hat{a}] = [a_0 : a_{10} : \dots : a_{0n}]$ in $P_{N-1}(\mathbb{C})$. We say that a sequence of degree n curves $f_i(x, y) = 0$ converges to a curve $f(x, y) = 0$ if and only if the sequence of points $[a_i] = [a_{i0} : a_{i10} \dots : a_{i0n}]$ converges to $[\hat{a}] = [a_0 : a_{10} : \dots : a_{0n}]$ in the topology of $P_{N-1}(\mathbb{C})$.

On the class **QS** acts the group of real affine transformations and time rescaling and due to this, modulo this group action quadratic systems ultimately depend on five parameters. This group also acts on **QSH** and modulo this action the **QSH** is 3-dimensional.

We observe that if we rescale the time $t' = \lambda t$ by a positive constant λ the geometry of the systems (1) does not change. So for our purposes we can identify a system (1) of degree n with a point in $[a_0 : a_{10} : \dots : b_{0n}]$ in $\mathbb{S}^{N-1}(\mathbb{R})$ with $N = (n+1)(n+2)$.

We compactify the space of all the polynomial differential systems of degree n on \mathbb{S}^{N-1} with $N = (n+1)(n+2)$ by multiplying the coefficients of each systems with $1 / \left(\sum (a_{ij}^2 + b_{ij}^2) \right)^{1/2}$.

Definition 3. 1. We say that an invariant curve $\mathcal{L} : f(x, y) = 0$, $f \in \mathbb{C}[x, y]$ for a polynomial system (S) of degree n has **multiplicity** m if there exists a sequence of real polynomial systems (S_k) of degree n converging to (S) in the topology of \mathbb{S}^{N-1} , $N = (n+1)(n+2)$, such that each (S_k) has m distinct invariant curves $\mathcal{L}_{1,k} : f_{1,k}(x, y) = 0, \dots, \mathcal{L}_{m,k} : f_{m,k}(x, y) = 0$ over \mathbb{C} , $\deg(f) = \deg(f_{i,k}) = r$, converging to \mathcal{L} as $k \rightarrow \infty$, in the topology of $P_{R-1}(\mathbb{C})$, with $R = (r+1)(r+2)/2$ and this does not occur for $m+1$.

2. We say that the line at infinity $\mathcal{L}_\infty : Z = 0$ of a polynomial system (S) of degree n has **multiplicity** m if there exists a sequence of real polynomial systems (S_k) of degree n converging to (S) in the topology of \mathbb{S}^{N-1} , $N = (n+1)(n+2)$, such that each (S_k) has $m-1$ distinct invariant lines $\mathcal{L}_{1,k} : f_{1,k}(x, y) = 0, \dots, \mathcal{L}_{m,k} : f_{m,k}(x, y) = 0$ over \mathbb{C} , converging to the line at infinity \mathcal{L}_∞ as $k \rightarrow \infty$, in the topology of $P_2(\mathbb{C})$ and this does not occur for m .

Definition 4. 1. Suppose a planar polynomial system (S) has a finite number of algebraic solutions \mathcal{L}_i , $i \leq k$, with corresponding multiplicities n_i and the line at infinity \mathcal{L}_∞ is not filled up with singularities and it has multiplicity n_∞ . We call **total multiplicity** of these algebraic solutions, including the multiplicity n_∞ of the line at infinity \mathcal{L}_∞ , the sum $TMC_{(S)} = n_1 + \dots + n_k + n_\infty$.

2. Suppose the system (S) has a finite number of real distinct singularities s_1, \dots, s_l , finite or infinite, which are located on the algebraic solutions, and s_1, \dots, s_l have the corresponding multiplicities m_1, \dots, m_l . We call **total multiplicity of the real singularities on the invariant curves** of (S) the sum $TMS_{(S)} = m_1 + \dots + m_l$ and TMS is the function defined by this expression.

An important ingredient in this work is the notion of *configuration of algebraic solution* of a polynomial differential system. This notion appeared for the first time in [24].

Definition 5. Consider a planar polynomial system which has a finite number of algebraic solutions and a finite number of singular points, finite or infinite. By **configuration of algebraic solutions**

of this system we mean the set of algebraic solutions over \mathbb{C} of the system, each one of these curves endowed with its own multiplicity and together with all the real singular points of this system located on these curves, each one of these singularities endowed with its own multiplicity.

We may have two distinct systems which may be non-equivalent modulo the action of the group but which may have “the same configuration” of invariant hyperbolas and straight lines. We need to say when two configurations are “the same” or equivalent.

Definition 6. *Suppose we have two systems $(S_1), (S_2)$ in **QSH** with a finite number of singularities, finite or infinite, a finite set of invariant hyperbolas $\mathcal{H}_i : h_i(x, y) = 0, i = 1, \dots, k$, of (S_1) (respectively $\mathcal{H}'_i : h'_i(x, y) = 0, i = 1, \dots, k$, of (S_2)) and a finite set (which could also be empty) of invariant straight lines $\mathcal{L}_j : f_j(x, y) = 0, j = 1, 2, \dots, k'$, of (S_1) (respectively $\mathcal{L}'_j : f'_j(x, y) = 0, j = 1, 2, \dots, k'$, of (S_2)). We say that the two configurations configurations C_1, C_2 of hyperbolas and lines of these systems are equivalent if there is a one-to-one correspondence ϕ_h between the hyperbolas of C_1 and C_2 and a one-to-one correspondence ϕ_l between the lines of C_1 and C_2 such that:*

- (i) *the correspondences conserve the multiplicities of the hyperbolas and lines (in case there are any) and also send a real invariant curve to a real invariant curve and a complex invariant curve to a complex invariant curve;*
- (ii) *for each hyperbola $\mathcal{H} : h(x, y) = 0$ of C_1 (respectively each line $\mathcal{L} : f(x, y) = 0$) we have a one-to-one correspondence between the real singular points on \mathcal{H} (respectively on \mathcal{L}) and the real singular points on $\phi_h(\mathcal{H})$ (respectively $\phi_l(\mathcal{L})$) conserving their multiplicities, their location on branches of hyperbolas and their order on these branches (respectively on the lines);*
- (iii) *Furthermore, consider the total curves $\mathcal{F} : \prod H_i(X, Y, X) \prod F_j(X, Y, Z)Z = 0$ (respectively $\mathcal{F}' : \prod H'_i(X, Y, X) \prod F'_j(X, Y, Z)Z = 0$ where $H_i(X, Y, X) = 0, F_j(X, Y, X) = 0$ (respectively $H'_i(X, Y, X) = 0, F'_j(X, Y, X) = 0$) are the projective completions of $\mathcal{H}_i, \mathcal{L}_j$ (respectively $\mathcal{H}'_i, \mathcal{L}'_j$). Then, there is a correspondence ψ between the singularities of the curves \mathcal{F} and \mathcal{F}' conserving their multiplicities as singular points of the total curves.*

In the family **QSH** we also have cases where we have an infinite number of hyperbolas. Thus, according to the theorem of Jouanolou (Theorem 2), we have a rational first integral. In this case the multiplicity of a hyperbola in the family is either considered to be undefined or we may say that this multiplicity is infinite. Such situations occur either when we have (i) a finite number of singularities, finite or infinite, or (ii) an infinite number of singularities which could only be at infinity (recall that the systems in **QSH** are non-degenerate). In both cases however we show that we have a finite number of affine invariant straight lines with finite multiplicities. In fact it was proved in [28] that all quadratic systems which have the line at infinity filled up with singularities have affine invariant straight lines of total multiplicity three. Furthermore, the multiplicities of singularities of the systems are finite in the case (i) and this is also true in case (ii) if we only take into consideration the affine lines. We therefore can talk about the *configuration of affine invariant lines associated to the system*. Two such configurations of affine invariant lines C_{1L}, C_{2L} associated to systems $(S_1), (S_2)$ are said to be equivalent if and only if there is a one-to-one correspondence ϕ_l between the lines of C_{1L} and C_{2L} such that:

- (i) the correspondence conserves the multiplicities of lines and also sends a real invariant line to a real invariant line and a complex invariant line to a complex invariant line;
- (ii) for each line $\mathcal{L} : f(x, y) = 0$ we have a one-to-one correspondence between the real singular points on \mathcal{L} and the real singular points on $\phi_l(\mathcal{L})$ conserving their multiplicities and their order on the lines.

We use this to extend our previous definition further above to cover these cases.

Definition 7. *Suppose we have two systems $(S_1), (S_2)$ in **QSH** with a finite number of finite singularities and an infinite number of invariant hyperbolas of (S_1) (respectively an infinite number of hyperbolas of (S_2)). Suppose we have a non-empty finite set of affine invariant straight lines $\mathcal{L}_j : f_j(x, y) = 0, j = 1, 2, \dots, k$, of (S_1) (respectively $\mathcal{L}'_j : f'_j(x, y) = 0, j = 1, 2, \dots, k$, of (S_2)). We now consider only the two configurations C_{1L}, C_{2L} of invariant affine lines of $(S_1), (S_2)$ associated to the systems. We say that the two configurations C_{1L}, C_{2L} are equivalent with respect to the hyperbolas of the systems if and only if (i) they are equivalent as configurations of invariant lines and in addition the following property (ii) is satisfied: we take any hyperbola $\mathcal{H} : h(x, y) = 0$ of (S_1) and any hyperbola $\mathcal{H}' : h'(x, y) = 0$ of (S_2) . Then, we must have a one-to-one correspondence between the real singular points of the system (S_1) located on \mathcal{H} and of real singular points of the system (S_2) located on \mathcal{H}' , conserving their multiplicities and their location and order on branches. Furthermore, consider the curves $\mathcal{F} : \prod h(x, y) \prod f_j(x, y) = 0$ and $\mathcal{F}' : \prod h'(x, y) \prod f'_j(x, y) = 0$. Then we have a one-to-one correspondence between the singularities of the curve \mathcal{F} with those of the curve \mathcal{F}' conserving their multiplicities as singular points of these curves.*

It can be easily shown that the definition above is independent of the choice of the two hyperbolas $\mathcal{H} : h(x, y) = 0$ of (S_1) and $\mathcal{H}' : h'(x, y) = 0$ of (S_2) .

In [15] the authors provide necessary and sufficient conditions for a non-degenerate quadratic differential system to have at least one invariant hyperbola and these conditions are expressed in terms of the coefficients of the systems. In this paper we denote by $\mathbf{QSH}_{(\eta>0)}$ the family of non-degenerate quadratic systems in **QSH** possessing three distinct real singularities at infinity and by $\mathbf{QSH}_{(\eta=0)}$ the systems in **QSH** possessing either exactly two distinct real singularities at infinity or the line at infinity filled up with singularities. We classify these families of systems, modulo the action of the group of real affine transformations and time rescaling, according to their geometric properties encoded in the configurations of invariant hyperbolas and/or invariant straight lines which these systems possess.

As we want this classification to be intrinsic, independent of the normal form given to the systems, we use here geometric invariants and invariant polynomials for the classification. For example, it is clear that the configuration of algebraic solutions of a system in **QSH** is an affine invariant. The classification is done according to the configurations of invariant hyperbolas and straight lines encountered in systems belonging to **QSH**. We put in the same equivalence class systems which have equivalent configurations of invariant hyperbolas and/or lines. In particular the notion of multiplicity in Definition 3 is invariant under the group action, i.e. if a quadratic system S has an invariant curve $\mathcal{L} = 0$ of multiplicity m , then each system S' in the orbit of S under the group action has a corresponding invariant line $\mathcal{L}' = 0$ of the same multiplicity m . To distinguish configurations of

algebraic solutions we need some geometric invariants, and we also use invariant polynomials both of which are introduced in our Section 2.

Main Theorem. *Consider the class **QSH** of all non-degenerate quadratic differential systems (3) possessing an invariant hyperbola.*

- (A) *This family is classified according to the configurations of invariant hyperbolas and of invariant straight lines of the systems, yielding 205 distinct such configurations, 162 of which belong to the class $\mathbf{QSH}_{(\eta>0)}$ and 43 to $\mathbf{QSH}_{(\eta=0)}$. This geometric classification is described in Theorems 5 and 6.*
- (B) *Using invariant polynomials, we obtain the bifurcation diagram in the space \mathbb{R}^{12} of the coefficients of the system in **QS** according to their configurations of invariant hyperbolas and invariant straight lines (this diagram is presented in part (B) of Theorems 5 and 6). Moreover, this diagram gives an algorithm to compute the configuration of a system with an invariant hyperbola for any quadratic differential system, presented in any normal form.*

2 Basic concepts and auxiliary results

In this section we define all the invariants we use in the Main Theorem and we state some auxiliary results. A quadratic system possessing an invariant hyperbola could also possess invariant lines. We classified the systems possessing an invariant hyperbola in terms of their configurations of invariant hyperbolas and invariant lines. Each one of these invariant curves has a multiplicity in the sense of Definition 3 (see also in [7]). We encode this picture in the multiplicity divisor of invariant hyperbolas and lines. We first recall the algebraic-geometric definition of an r -cycle on an irreducible algebraic variety of dimension n .

Definition 8. *Let V be an irreducible algebraic variety of dimension n over a field K . A cycle of dimension r or r -cycle on V is a formal sum $\sum n_W W$, where W is a subvariety of V of dimension r which is not contained in the singular locus of V , $n_W \in \mathbb{Z}$, and only a finite number of n_W 's are non-zero. We call **degree of an r -cycle** the sum $\sum n_W$. An $(n-1)$ -cycle is called a **divisor**.*

Definition 9. *Let V be an irreducible algebraic variety over a field K . The **support of a cycle** C on V is the set $\text{Supp}(C) = \{W | n_W \neq 0\}$. We denote by $\text{Max}(C)$ the maximum value of the coefficients n_W in C . For every $m \leq \text{Max}(C)$ let $s(m)$ be the number of the coefficients n_W in C which are equal to m . We call **type of the cycle** C the set of ordered couples $(s(m), m)$ where $1 \leq m \leq \text{Max}(C)$.*

Clearly the degree and the type of an r -cycle are invariant under the action of the group of real affine transformations and time rescaling.

For a non-degenerate polynomial differential systems (S) possessing a finite number of algebraic solutions $f_i(x, y) = 0$, each with multiplicity n_i and a finite number of singularities at infinity, we define the *algebraic solutions divisor* on the projective plane, $ICD = \sum n_i n_i \mathcal{C}_i + n_\infty \mathcal{L}_\infty$ (also called the *invariant curves divisor*) where $\mathcal{C}_i : F_i(X, Y, Z) = 0$ are the projective completions of $f_i(x, y) = 0$, n_i is the multiplicity of the curve $\mathcal{C}_i = 0$ and n_∞ is the multiplicity of the line at infinity $\mathcal{L}_\infty : Z = 0$.

It is well known (see [2]) that the maximum number of invariant straight lines, including the line at infinity, for polynomial systems of degree $n \geq 2$ is $3n$.

In the case we consider here, we have a particular instance of the divisor ICD because the invariant curves will be invariant hyperbolas and invariant lines of a quadratic differential system, in case these are in finite number. In case we have an infinite number of hyperbolas we use only the invariant lines to construct the divisor.

Another ingredient of the configuration of algebraic solutions are the real singularities situated on these curves. We also need to use here the notion of multiplicity divisor of real singularities of a system located on the algebraic solutions of the system.

Definition 10. 1. Suppose a real quadratic system has a finite number of invariant hyperbolas $\mathcal{H}_i : h_i(x, y) = 0$ $i = 1, \dots, k$ and a finite number of affine invariant lines $\mathcal{L}_j : f_j(x, y) = 0$, $j = 1, \dots, l$. We denote the line at infinity $\mathcal{L}_\infty : Z = 0$. Let us assume that on the line at infinity we have a finite number of singularities. The divisor of invariant hyperbolas and invariant lines on the complex projective plane of the system is the following:

$$ICD = n_1\mathcal{H}_1 + \dots + n_k\mathcal{H}_k + m_1\mathcal{L}_1 + \dots + m_l\mathcal{L}_l + m_\infty\mathcal{L}_\infty,$$

where n_i (respectively m_j) is the multiplicity of the hyperbola \mathcal{H}_i (respectively m_j of the line \mathcal{L}_j), and m_∞ is the multiplicity of \mathcal{L}_∞ . We also mark the complex (non-real) invariant hyperbolas (respectively lines) denoting them by \mathcal{H}_i^C (respectively \mathcal{L}_i^C). We define the total multiplicity TMH of invariant hyperbolas as the sum $\sum_i n_i$ and the total multiplicity TML of invariant line as the sum $\sum_i m_i$. We denote by IHD (respectively ILD) the invariant hyperbolas divisor (respectively the invariant lines divisor) i.e. $IHD = n_1\mathcal{H}_1 + \dots + n_k\mathcal{H}_k$ (respectively $ILD = m_\infty\mathcal{L}_\infty + m_1\mathcal{L}_1 + \dots + m_l\mathcal{L}_l$).

2. The zero-cycle on the real projective plane, of real singularities of a system (3) located on the configuration of invariant lines and invariant hyperbolas, is given by:

$$MS_{0C} = r_1U_1 + \dots + r_lU_l + v_1s_1 + \dots + v_ns_n,$$

where U_i (respectively s_j) are all the real infinite (respectively finite) such singularities of the system and r_i (respectively v_j) are their corresponding multiplicities.

In the family **QSH** we have configurations which have an infinite number of hyperbolas. These are of two kinds: those with a finite number of singular points at infinity, and those with the line at infinity filled up with singularities. To distinguish these two cases we define $|Sing_\infty|$ to be the cardinality of the set of singular points at infinity of the systems. In the first case we have $|Sing_\infty| = 2$ or 3 , and in the second case $|Sing_\infty|$ is the continuum and we simply write $|Sing_\infty| = \infty$. Since in both cases the systems admit a finite number of affine invariant straight lines we can use them to distinguish the configurations.

Definition 11. 1. In case we have an infinite number of hyperbolas and just two or three singular points at infinity but we have a finite number of invariant straight lines we define $ILD = m_1\mathcal{L}_1 + \dots + m_k\mathcal{L}_k + m_\infty\mathcal{L}_\infty$ (see Definition 10);

2. In case we have an infinite number of hyperbolas, the line at infinity is filled up with singularities and we have a finite number of affine lines, we define $ILD = m_1\mathcal{L}_1 + \dots + m_k\mathcal{L}_k$.

Attached to the divisors and the zero-cycle we defined, we have their *types* which are clearly affine invariants. So although the cycles ICD and MS_{0C} are not themselves affine invariants, they are used in the classification because we can read on them several specific invariants, such as for example their types, TMS , TMC , etc.

The above defined divisor ICD and zero-cycle MS_{0C} contain several invariants such as the number of invariant lines and their total multiplicity TML , the number of invariant hyperbolas (in case these are in finite number) and their total multiplicity TMH , the number of complex invariant hyperbolas of a real system, etc.

There are two compactifications which intervene in the classification of **QSH** according to the configurations of the systems: the compactification in the Poincaré disk and the compactification of its associated foliation with singularities on the real projective plane $P_2(\mathbb{R})$. We also have the compactification of its associated (complex) foliation with singularities on the complex projective plane. Each one of these compactifications plays a role in the classification. In the compactified system the line at infinity of the affine plane is an invariant line. The system may have singular points located at infinity which are not points of intersection of invariant curves, points also denoted by U_r .

The real singular points at infinity (respectively the real finite singular points) which are intersection point of two or more invariant algebraic curves are denoted by $\overset{j}{U}_r$ (respectively by $\overset{j}{s}_r$), where $j \in \{h, l, hh, hl, ll, llh^\infty, \dots\}$. Here h (respectively $l, hh, hl, ll, llh^\infty, \dots$) means that the intersection of the infinite line with a hyperbola (respectively with a line, or with two hyperbolas, or with a hyperbola and a line, or with two lines, or with two line and infinity number of hyperbolas etc.). In other words, whenever the symbol h^∞ appears in the divisor MS_{0C} it means that the singularity lies on an infinity number of hyperbolas.

Suppose we have a finite number of real invariant hyperbolas and real invariant straight lines of a system (S) and that they are given by equations $f_i(x, y) = 0$, $i \in \{1, 2, \dots, k\}$, $f_i \in \mathbb{R}[x, y]$. Let us denote by $F_i(X, Y, Z) = 0$ the projection completion of the invariant curves $f_i = 0$ in $P_2(\mathbb{R})$.

Definition 12. *The total invariant curve of the system (S) in **QSH**, on $P_2(\mathbb{C})$, is the curve $\mathcal{T}(S) : \coprod F_i(X, Y, Z)Z = 0$.*

We use the above notion to define the *basic curvilinear polygons determined by the total curve $\mathcal{T}(S)$* . Consider the Poincaré disk and remove from it the (real) points of the total curve $\mathcal{T}(S)$. We are left with a certain number of 2-dimensional connected components.

Definition 13. *We call basic polygon determined by $\mathcal{T}(S)$ the closure of anyone of these components associated to $\mathcal{T}(S)$.*

Although a basic polygon is a 2-dimensional object, we shall think of it as being just its border.

The singular points of the system (S) situated on $T(S)$, they are of two kinds: those which are simple (or smooth) points of $\mathcal{T}(S)$ and those which are multiple points of $\mathcal{T}(S)$.

Remark 1. *To each singular point of the system we have its associated multiplicity as a singular point of the system. In addition, we also have the multiplicity of these points as points on the total curve. Through a singular point of the systems there may pass several of the curves $F_i = 0$ and $Z = 0$. Also we may have the case when this point is a singular point of one or even of several of the curves in case we work with invariant curves with singularities. This leads to the multiplicity of the point as point of the curve $\mathcal{T}(S)$. The simple points are those of multiplicity one. They are also the smooth points of this curve.*

The real singular points of the system which are simple points of $\mathcal{T}(S)$ are useful for defining some geometrical invariants, helpful in the geometrical classification, besides those which can be read from the zero-cycle defined further above.

We now introduce the notion of *minimal proximity polygon* of a singular point of the total curve. This notion plays a major role in the geometrical classification of the systems.

Definition 14. *Suppose a system (S) has a finite number of singular points and a finite number of invariant hyperbolas and straight lines. Let p be a real singular point of a system lying on $\mathcal{T}(S)$ and in the Poincaré disk. Then p may belong to several basic polygons. We call **minimal proximity polygon of p** a basic polygon on which p is located and which has the minimum number of vertices, among the basic polygons to which p belongs. In case we have more than one polygon with the minimum number of vertices, we take all such polygons as being minimal proximity polygons of p .*

Remark 2. *We observe that for systems in QSH we have a basic polygon located in the finite plane only in one case (Config. H.36) and the polygon is a triangle. All other polygons have at least one vertex at infinity.*

For a configuration C , consider for each real singularity p of the system which is a simple point of the curve $\mathcal{T}(S)$, its minimal proximity basic polygons. We construct some formal finite sums attached to the Poincaré disk, analogs of the algebraic-geometric notion of divisor on the projective plane. For this we proceed as follows:

We first list all real singularities of the systems on the Poincaré disk which are simple points (*ss* points) of the total curve. In case we have such points U_i 's located on the line at infinity, we start with those points which are at infinity. We obtain a list $U_1, \dots, U_n, s_1, \dots, s_k$, where s_i 's are finite points. Associate to U_1, \dots, U_n their minimal proximity polygons $\mathcal{P}_1, \dots, \mathcal{P}_m$. In case some of them coincide we only list once the polygons which are repeated. These minimal proximity polygons may contain some finite points from the list s_1, \dots, s_k . We remove all such points from this list. Suppose we are left with the finite points s'_1, \dots, s'_r . For these points we associate their corresponding minimal proximity polygons. We observe that for a point s'_j we may have two minimal proximity polygons in which case we consider only the minimal proximity polygon which has the maximum number of singularities s_j , simple points of the total curve. If the two polygons have the same maximum number of simple (*ss*) points then we take the two of them. We obtain a list of polygons and we retain from this list only that polygon (or those polygons) which have the maximal number of *ss* points and add these polygons to the list $\mathcal{P}_1, \dots, \mathcal{P}_n$. We remove all the *ss* points which appear in this list of polygons from the list of points s'_1, \dots, s'_r and continue the same process until there are no points left from the sequence s_1, \dots, s_k which have not being included or eliminated. We thus end up with a list $\mathcal{P}_1, \dots, \mathcal{P}_r$ of proximity polygons which we denote by $\mathcal{P}(C)$.

Definition 15. We denote by PD the proximity “divisor” of the Poincaré disk

$$PD = v_1\mathcal{P}_1 + \cdots + v_r\mathcal{P}_r,$$

associated to the list $\mathcal{P}(C)$ of the minimal proximity polygons of a configuration, where \mathcal{P}_i are the minimal proximity polygons from this list and v_i are their corresponding number of vertices.

We used the word *divisor* of the Poincaré disk in analogy with divisor on the projective plane, also thinking of polygons as the borders of the 2-dimensional polygons.

The next divisor considers the proximity polygons in PD but only the ones attached to the finite singular points of the system which are simple points on the total curve. So this time we start with all such points s_1, \dots, s_k and build up the divisor like we did before. The result is called “*the proximity divisor of the real finite singular points of the systems, simple points of the total curve*” and we denote it by PD_f .

We also define a divisor on the Poincaré disk which encodes the way the minimal proximity polygons intersect the line at infinity.

Definition 16. We denote by PD_∞ the “divisor” of the Poincaré disk encoding the way the proximity polygons in PD intersect the infinity and define it as

$$PD_\infty = \sum_{\mathcal{P}} n_{\mathcal{P}}\mathcal{P},$$

where \mathcal{P} is a proximity polygon in PD and $n_{\mathcal{P}}$ is 3 if \mathcal{P} has one of its sides on the line at infinity, it is 2 if \mathcal{P} has only two vertices on the line at infinity, it is 1 if only one of its vertices lies on the line at infinity and it is 0 if \mathcal{P} is finite.

Definition 17. For a proximity polygon \mathcal{P} we introduce the multiplicity divisor

$$m\mathcal{P} = \sum m(v) v,$$

where v is a vertex of \mathcal{P} and $m(v)$ is the multiplicity of the singular point v of the system.

In case a configuration C has an invariant hyperbola \mathcal{H} and an invariant line \mathcal{L} , we define the following invariant I which helps us decide the type of their intersection.

Definition 18. Suppose we have an invariant line \mathcal{L} and an invariant hyperbola \mathcal{H} of a polynomial differential system (S) . We define the invariant I attached to the couple \mathcal{L}, \mathcal{H} as being: 0 if and only if \mathcal{L} intersects \mathcal{H} in two complex non-real points; 1 if and only if \mathcal{L} is tangent to \mathcal{H} ; 21 if and only if \mathcal{L} intersects \mathcal{H} in two real points and both these points lie on only one branch of the hyperbola; 22 if and only if \mathcal{L} intersects \mathcal{H} in two real points and these points lie on distinct branches of the hyperbola. In case for a configuration C we have several hyperbolas \mathcal{H}_i , $i \in \{1, 2, \dots, r\}$ and an invariant line \mathcal{L} , then $I = \{I(\mathcal{L}, \mathcal{H}_1), I(\mathcal{L}, \mathcal{H}_2), \dots, I(\mathcal{L}, \mathcal{H}_r)\}$.

Definition 19. We define a function O (for “order”), $O: \mathbf{QSH} \rightarrow \{1, 0, -1\}$ as follows: Suppose a system (S) in \mathbf{QSH} has two singular points at infinity, one simple U_1 and the other double U_2 . Suppose the system has only one invariant hyperbola and only two real finite singular points s_1 and s_2 lying on a branch of an invariant hyperbola connecting U_1 with U_2 such that s_2 is double and s_1

is simple. We have only two possibilities: either the segment of hyperbola connecting the two double singularities U_2 and s_2 contains s_1 in which case we write $O(S) = 1$ or it does not contain s_1 and then we write $O(S) = 0$. In case we have a configuration where this specific situation does not occur we write $O(S) = -1$.

A few more definitions and results which play an important role in the proof of the part (B) of the Main Theorem are needed. We do not prove these results here but we indicate where they can be found.

Consider the differential operator $\mathcal{L} = x \cdot \mathbf{L}_2 - y \cdot \mathbf{L}_1$ constructed in [4] and acting on $\mathbb{R}[\tilde{a}, x, y]$, where

$$\begin{aligned}\mathbf{L}_1 &= 2a_{00} \frac{\partial}{\partial a_{10}} + a_{10} \frac{\partial}{\partial a_{20}} + \frac{1}{2}a_{01} \frac{\partial}{\partial a_{11}} + 2b_{00} \frac{\partial}{\partial b_{10}} + b_{10} \frac{\partial}{\partial b_{20}} + \frac{1}{2}b_{01} \frac{\partial}{\partial b_{11}}, \\ \mathbf{L}_2 &= 2a_{00} \frac{\partial}{\partial a_{01}} + a_{01} \frac{\partial}{\partial a_{02}} + \frac{1}{2}a_{10} \frac{\partial}{\partial a_{11}} + 2b_{00} \frac{\partial}{\partial b_{01}} + b_{01} \frac{\partial}{\partial b_{02}} + \frac{1}{2}b_{10} \frac{\partial}{\partial b_{11}}.\end{aligned}$$

Using this operator and the affine invariant $\mu_0 = \text{Res}_x(p_2(\tilde{a}, x, y), q_2(\tilde{a}, x, y))/y^4$ we construct the following polynomials

$$\mu_i(\tilde{a}, x, y) = \frac{1}{i!} \mathcal{L}^{(i)}(\mu_0), \quad i = 1, \dots, 4,$$

where $\mathcal{L}^{(i)}(\mu_0) = \mathcal{L}(\mathcal{L}^{(i-1)}(\mu_0))$ and $\mathcal{L}^{(0)}(\mu_0) = \mu_0$.

These polynomials are in fact comitants of systems (3) with respect to the group $GL(2, \mathbb{R})$ (see [4]). Their geometrical meaning is revealed in the next lemma.

Lemma 1. ([3],[4]) *Assume that a quadratic system (S) with coefficients \tilde{a} belongs to the family (3). Then:*

(i) *Let λ be an integer such that $\lambda \leq 4$. The total multiplicity of all finite singularities of this system equals $4 - \lambda$ if and only if for every $i \in \{0, 1, \dots, \lambda - 1\}$ we have $\mu_i(\tilde{a}, x, y) = 0$ in the ring $\mathbb{R}[x, y]$ and $\mu_\lambda(\tilde{a}, x, y) \neq 0$. In this case, the factorization $\mu_\lambda(\tilde{a}, x, y) = \prod_{i=1}^\lambda (u_i x - v_i y) \neq 0$ over \mathbb{C} indicates the coordinates $[v_i : u_i : 0]$ of those finite singularities of the system (S) which “have gone” to infinity. Moreover, the number of distinct factors in this factorization is less than or equal to three (the maximum number of infinite singularities of a quadratic system in the projective plane) and the multiplicity of each one of the factors $u_i x - v_i y$ gives us the number of the finite singularities of the system (S) which have coalesced with the infinite singular point $[v_i : u_i : 0]$.*

(ii) *The system (S) is degenerate (i.e. $\gcd(P, Q) \neq \text{const}$) if and only if $\mu_i(\tilde{a}, x, y) = 0$ in $\mathbb{R}[x, y]$ for every $i = 0, 1, 2, 3, 4$.*

The following zero-cycle on the complex plane was introduced in [12] based on previous work in [22].

Definition 20. *We define $\mathcal{D}_{\mathbb{C}^2}(S) = \sum_{s \in \mathbb{C}^2} n_s s$ where n_s is the intersection multiplicity at s of the curves $p(x, y) = 0$, $q(x, y) = 0$, p, q being the polynomials defining the equations (1) for system (S).*

Proposition 1. ([33]) *The form of the zero-cycle $\mathcal{D}_{\mathbb{C}^2}(S)$ for non-degenerate quadratic systems (3) is determined by the corresponding conditions indicated in TABLE 1, where we write $p + q + r^c + s^c$*

TABLE 1: Number and multiplicity of the finite singular points of **QS**

No.	Zero-cycle $\mathcal{D}_{\mathbb{C}^2}(S)$	Invariant criteria	No.	Zero-cycle $\mathcal{D}_{\mathbb{C}^2}(S)$	Invariant criteria
1	$p + q + r + s$	$\mu_0 \neq 0, \mathbf{D} < 0,$ $\mathbf{R} > 0, \mathbf{S} > 0$	10	$p + q + r$	$\mu_0 = 0, \mathbf{D} < 0, \mathbf{R} \neq 0$
2	$p + q + r^c + s^c$	$\mu_0 \neq 0, \mathbf{D} > 0$	11	$p + q^c + r^c$	$\mu_0 = 0, \mathbf{D} > 0, \mathbf{R} \neq 0$
3	$p^c + q^c + r^c + s^c$	$\mu_0 \neq 0, \mathbf{D} < 0, \mathbf{R} \leq 0$ $\mu_0 \neq 0, \mathbf{D} < 0, \mathbf{S} \leq 0$	12	$2p + q$	$\mu_0 = \mathbf{D} = 0, \mathbf{PR} \neq 0$
4	$2p + q + r$	$\mu_0 \neq 0, \mathbf{D} = 0, \mathbf{T} < 0$	13	$3p$	$\mu_0 = \mathbf{D} = \mathbf{P} = 0, \mathbf{R} \neq 0$
5	$2p + q^c + r^c$	$\mu_0 \neq 0, \mathbf{D} = 0, \mathbf{T} > 0$	14	$p + q$	$\mu_0 = \mathbf{R} = 0, \mathbf{P} \neq 0,$ $\mathbf{U} > 0$
6	$2p + 2q$	$\mu_0 \neq 0, \mathbf{D} = \mathbf{T} = 0,$ $\mathbf{PR} > 0$	15	$p^c + q^c$	$\mu_0 = \mathbf{R} = 0, \mathbf{P} \neq 0,$ $\mathbf{U} < 0$
7	$2p^c + 2q^c$	$\mu_0 \neq 0, \mathbf{D} = \mathbf{T} = 0,$ $\mathbf{PR} < 0$	16	$2p$	$\mu_0 = \mathbf{R} = 0, \mathbf{P} \neq 0,$ $\mathbf{U} = 0$
8	$3p + q$	$\mu_0 \neq 0, \mathbf{D} = \mathbf{T} = 0,$ $\mathbf{P} = 0, \mathbf{R} \neq 0$	17	p	$\mu_0 = \mathbf{R} = \mathbf{P} = 0,$ $\mathbf{U} \neq 0$
9	$4p$	$\mu_0 \neq 0, \mathbf{D} = \mathbf{T} = 0,$ $\mathbf{P} = \mathbf{R} = 0$	18	0	$\mu_0 = \mathbf{R} = \mathbf{P} = 0,$ $\mathbf{U} = 0, \mathbf{V} \neq 0$

if two of the finite points, i.e. r^c, s^c , are complex but not real, and

$$\begin{aligned}
 \mathbf{D} &= \left[3((\mu_3, \mu_3)^{(2)}, \mu_2)^{(2)} - (6\mu_0\mu_4 - 3\mu_1\mu_3 + \mu_2^2, \mu_4)^{(4)} \right] / 48, \\
 \mathbf{P} &= 12\mu_0\mu_4 - 3\mu_1\mu_3 + \mu_2^2, \\
 \mathbf{R} &= 3\mu_1^2 - 8\mu_0\mu_2, \\
 \mathbf{S} &= \mathbf{R}^2 - 16\mu_0^2\mathbf{P}, \\
 \mathbf{T} &= 18\mu_0^2(3\mu_3^2 - 8\mu_2\mu_4) + 2\mu_0(2\mu_2^3 - 9\mu_1\mu_2\mu_3 + 27\mu_1^2\mu_4) - \mathbf{PR}, \\
 \mathbf{U} &= \mu_3^2 - 4\mu_2\mu_4, \\
 \mathbf{V} &= \mu_4.
 \end{aligned} \tag{4}$$

The next result is stated in [15] and it gives us the necessary and sufficient conditions for the existence of at least one invariant hyperbola for non-degenerate systems (3) and also their multiplicities. The invariant polynomials which appears in the statement of the next theorem and in the corresponding diagrams are constructed in [15] and we present them further below.

Theorem 3. ([15]) **(A)** *The conditions $\gamma_1 = \gamma_2 = 0$ and either $\eta \geq 0, M \neq 0$ or $C_2 = 0$ are necessary for a quadratic system in the class **QS** to possess at least one invariant hyperbola.*

(B) *Assume that for a system in the class **QS** the condition $\gamma_1 = \gamma_2 = 0$ is satisfied.*

- **(B₁)** *If $\eta > 0$ then the necessary and sufficient conditions for this system to possess at least one invariant hyperbola are given in DIAGRAM 1, where we can also find the number and multiplicity of such hyperbolas.*

- **(B₂)** In the case $\eta = 0$ and either $M \neq 0$ or $C_2 = 0$ the corresponding necessary and sufficient conditions for this system to possess at least one invariant hyperbola are given in DIAGRAM 2, where we can also find the number and multiplicity of such hyperbolas.

(C) The DIAGRAMS 1 and 2 actually contain the global bifurcation diagram in the 12-dimensional space of parameters of the coefficients of the systems belonging to family **QS**, which possess at least one invariant hyperbola. The corresponding conditions are given in terms of invariant polynomials with respect to the group of real affine transformations and time rescaling.

Remark 3. An invariant hyperbola is denoted by \mathcal{H} if it is real and by $\overset{c}{\mathcal{H}}$ if it is complex. In the case we have two such hyperbolas then it is necessary to distinguish whether they have parallel or non-parallel asymptotes in which case we denote them by \mathcal{H}^P ($\overset{c}{\mathcal{H}}^P$) if their asymptotes are parallel and by \mathcal{H} if there exists at least one pair of non-parallel asymptotes. We denote by \mathcal{H}_k ($k = 2, 3$) a hyperbola with multiplicity k ; by \mathcal{H}_2^P a double hyperbola, which after perturbation splits into two \mathcal{H}^P ; and by \mathcal{H}_3^P a triple hyperbola which splits into two \mathcal{H}^P and one \mathcal{H} .

Following [15] we present here the invariant polynomials which according to DIAGRAMS 1 and 2 are responsible for the existence and the number of invariant hyperbolas which systems (3) could possess.

First we single out the following five polynomials, basic ingredients in constructing invariant polynomials for systems (3):

$$\begin{aligned} C_i(\tilde{a}, x, y) &= yp_i(x, y) - xq_i(x, y), \quad (i = 0, 1, 2) \\ D_i(\tilde{a}, x, y) &= \frac{\partial p_i}{\partial x} + \frac{\partial q_i}{\partial y}, \quad (i = 1, 2). \end{aligned} \quad (5)$$

As it was shown in [31] these polynomials of degree one in the coefficients of systems (3) are GL -comitants of these systems. Let $f, g \in \mathbb{R}[\tilde{a}, x, y]$ and

$$(f, g)^{(k)} = \sum_{h=0}^k (-1)^h \binom{k}{h} \frac{\partial^k f}{\partial x^{k-h} \partial y^h} \frac{\partial^k g}{\partial x^h \partial y^{k-h}}.$$

The polynomial $(f, g)^{(k)} \in \mathbb{R}[\tilde{a}, x, y]$ is called *the transvectant of index k of (f, g)* (cf. [9], [17]).

Theorem 4 (see [34]). *Any GL -comitant of systems (3) can be constructed from the elements (5) by using the operations: $+$, $-$, \times , and by applying the differential operation $(*, *)^{(k)}$.*

Remark 4. *We point out that the elements (5) generate the whole set of GL -comitants and hence also the set of affine comitants as well as the set of T -comitants and CT -comitants (see [24] for detailed definitions).*

We construct the following GL -comitants of the second degree with respect to the coefficients of the initial systems

$$\begin{aligned} T_1 &= (C_0, C_1)^{(1)}, & T_2 &= (C_0, C_2)^{(1)}, & T_3 &= (C_0, D_2)^{(1)}, \\ T_4 &= (C_1, C_1)^{(2)}, & T_5 &= (C_1, C_2)^{(1)}, & T_6 &= (C_1, C_2)^{(2)}, \\ T_7 &= (C_1, D_2)^{(1)}, & T_8 &= (C_2, C_2)^{(2)}, & T_9 &= (C_2, D_2)^{(1)}. \end{aligned} \quad (6)$$

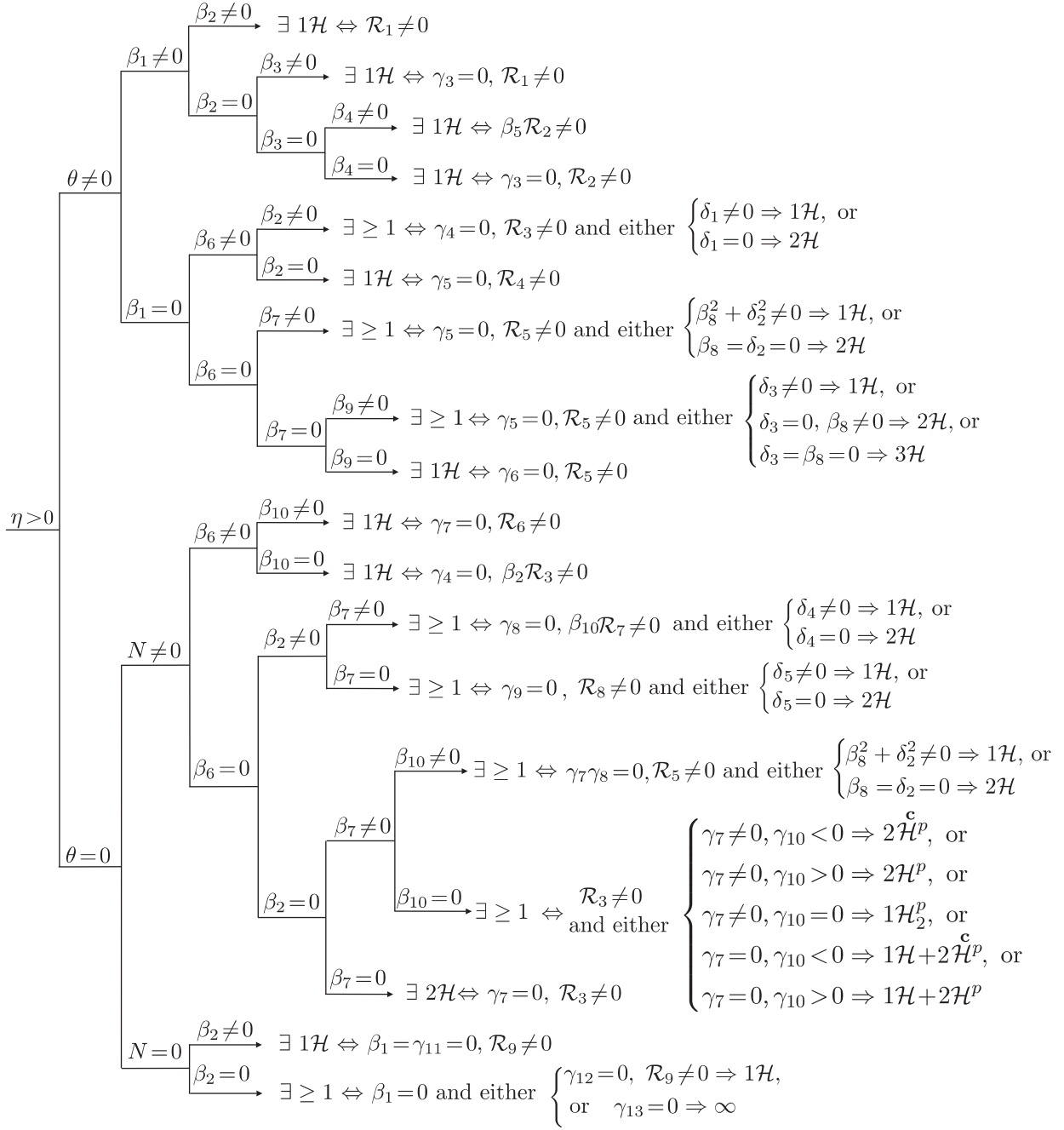

DIAGRAM 1: **Existence of invariant hyperboloids: the case $\eta > 0$**

Using these GL -comitants as well as the polynomials (5) we construct additional invariant polynomials. In order to be able to directly calculate the values of the invariant polynomials we need, for every canonical system we define here a family of T -comitants expressed through C_i ($i = 0, 1, 2$)

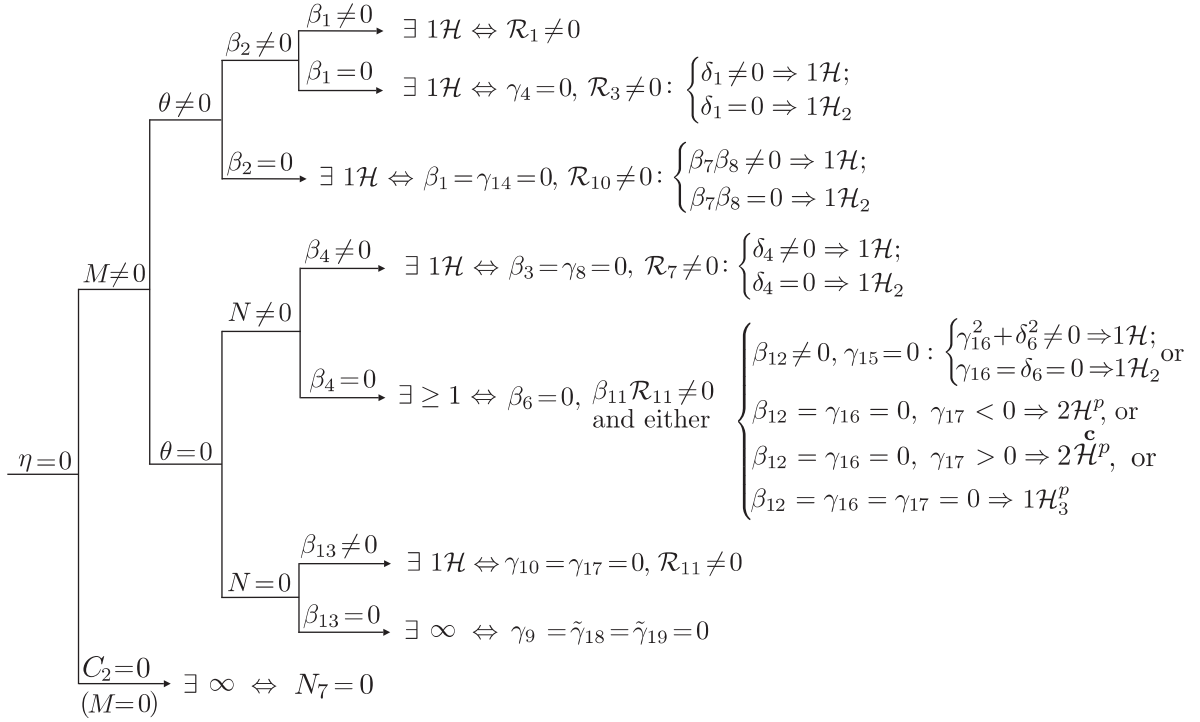

DIAGRAM 2: Existence of invariant hyperboloids: the case $\eta = 0$

and D_j ($j = 1, 2$):

$$\begin{aligned}
\hat{A} &= (C_1, T_8 - 2T_9 + D_2^2)^{(2)} / 144, \\
\hat{D} &= [2C_0(T_8 - 8T_9 - 2D_2^2) + C_1(6T_7 - T_6 - (C_1, T_5)^{(1)} + 6D_1(C_1D_2 - T_5) - 9D_1^2C_2)] / 36, \\
\hat{E} &= [D_1(2T_9 - T_8) - 3(C_1, T_9)^{(1)} - D_2(3T_7 + D_1D_2)] / 72, \\
\hat{F} &= [6D_1^2(D_2^2 - 4T_9) + 4D_1D_2(T_6 + 6T_7) + 48C_0(D_2, T_9)^{(1)} - 9D_2^2T_4 + 288D_1\hat{E} \\
&\quad - 24(C_2, \hat{D})^{(2)} + 120(D_2, \hat{D})^{(1)} - 36C_1(D_2, T_7)^{(1)} + 8D_1(D_2, T_5)^{(1)}] / 144, \\
\hat{B} &= \{16D_1(D_2, T_8)^{(1)}(3C_1D_1 - 2C_0D_2 + 4T_2) + 32C_0(D_2, T_9)^{(1)}(3D_1D_2 - 5T_6 + 9T_7) \\
&\quad + 2(D_2, T_9)^{(1)}(27C_1T_4 - 18C_1D_1^2 - 32D_1T_2 + 32(C_0, T_5)^{(1)}) \\
&\quad + 6(D_2, T_7)^{(1)}[8C_0(T_8 - 12T_9) - 12C_1(D_1D_2 + T_7) + D_1(26C_2D_1 + 32T_5) + C_2(9T_4 + 96T_3)] \\
&\quad + 6(D_2, T_6)^{(1)}[32C_0T_9 - C_1(12T_7 + 52D_1D_2) - 32C_2D_1^2] + 48D_2(D_2, T_1)^{(1)}(2D_2^2 - T_8) \\
&\quad - 32D_1T_8(D_2, T_2)^{(1)} + 9D_2^2T_4(T_6 - 2T_7) - 16D_1(C_2, T_8)^{(1)}(D_1^2 + 4T_3) \\
&\quad + 12D_1(C_1, T_8)^{(2)}(C_1D_2 - 2C_2D_1) + 6D_1D_2T_4(T_8 - 7D_2^2 - 42T_9) \\
&\quad + 12D_1(C_1, T_8)^{(1)}(T_7 + 2D_1D_2) + 96D_2^2[D_1(C_1, T_6)^{(1)} + D_2(C_0, T_6)^{(1)}] - \\
&\quad - 16D_1D_2T_3(2D_2^2 + 3T_8) - 4D_1^3D_2(D_2^2 + 3T_8 + 6T_9) + 6D_1^2D_2^2(7T_6 + 2T_7) \\
&\quad - 252D_1D_2T_4T_9\} / (2^8 3^3), \\
\hat{K} &= (T_8 + 4T_9 + 4D_2^2) / 72, \quad \hat{H} = (8T_9 - T_8 + 2D_2^2) / 72, \quad \hat{N} = 4\hat{K} - 4\hat{H}.
\end{aligned}$$

These polynomials in addition to (5) and (6) will serve as bricks in constructing affine invariant polynomials for systems (3).

Using the above bricks, the following 42 affine invariants A_1, \dots, A_{42} are constructed from the minimal polynomial basis of affine invariants up to degree 12. This fact was proved in [5].

$$\begin{aligned}
A_1 &= \hat{A}, & A_{22} &= \frac{1}{1152} [C_2, \hat{D}]^{(1)}, D_2^{(1)}, D_2^{(1)}, D_2^{(1)} D_2^{(1)}, \\
A_2 &= (C_2, \hat{D})^{(3)}/12, & A_{23} &= [\hat{F}, \hat{H}]^{(1)}, \hat{K}^{(2)}/8, \\
A_3 &= [C_2, D_2]^{(1)}, D_2^{(1)}, D_2^{(1)}/48, & A_{24} &= [C_2, \hat{D}]^{(2)}, \hat{K}^{(1)}, \hat{H}^{(2)}/32, \\
A_4 &= (\hat{H}, \hat{H})^{(2)}, & A_{25} &= [\hat{D}, \hat{D}]^{(2)}, \hat{E}^{(2)}/16, \\
A_5 &= (\hat{H}, \hat{K})^{(2)}/2, & A_{26} &= /36, \\
A_6 &= (\hat{E}, \hat{H})^{(2)}/2, & A_{27} &= [\hat{B}, D_2]^{(1)}, \hat{H}^{(2)}/24, \\
A_7 &= [C_2, \hat{E}]^{(2)}, D_2^{(1)}/8, & A_{28} &= [C_2, \hat{K}]^{(2)}, \hat{D}^{(1)}, \hat{E}^{(2)}/16, \\
A_8 &= [\hat{D}, \hat{H}]^{(2)}, D_2^{(1)}/8, & A_{29} &= [\hat{D}, \hat{F}]^{(1)}, \hat{D}^{(3)}/96, \\
A_9 &= [\hat{D}, D_2]^{(1)}, D_2^{(1)}, D_2^{(1)}/48, & A_{30} &= [C_2, \hat{D}]^{(2)}, \hat{D}^{(1)}, \hat{D}^{(3)}/288, \\
A_{10} &= [\hat{D}, \hat{K}]^{(2)}, D_2^{(1)}/8, & A_{31} &= [\hat{D}, \hat{D}]^{(2)}, \hat{K}^{(1)}, \hat{H}^{(2)}/64, \\
A_{11} &= (\hat{F}, \hat{K})^{(2)}/4, & A_{32} &= [\hat{D}, \hat{D}]^{(2)}, D_2^{(1)}, \hat{H}^{(1)}, D_2^{(1)}/64, \\
A_{12} &= (\hat{F}, \hat{H})^{(2)}/4, & A_{33} &= [\hat{D}, D_2]^{(1)}, \hat{F}^{(1)}, D_2^{(1)}, D_2^{(1)}/128, \\
A_{13} &= [C_2, \hat{H}]^{(1)}, \hat{H}^{(2)}, D_2^{(1)}/24, & A_{34} &= [\hat{D}, \hat{D}]^{(2)}, D_2^{(1)}, \hat{K}^{(1)}, D_2^{(1)}/64, \\
A_{14} &= (\hat{B}, C_2)^{(3)}/36, & A_{35} &= [\hat{D}, \hat{D}]^{(2)}, \hat{E}^{(1)}, D_2^{(1)}, D_2^{(1)}/128, \\
\\
A_{15} &= (\hat{E}, \hat{F})^{(2)}/4, & A_{36} &= [\hat{D}, \hat{E}]^{(2)}, \hat{D}^{(1)}, \hat{H}^{(2)}/16, \\
A_{16} &= [\hat{E}, D_2]^{(1)}, C_2^{(1)}, \hat{K}^{(2)}/16, & A_{37} &= [\hat{D}, \hat{D}]^{(2)}, \hat{D}^{(1)}, \hat{D}^{(3)}/576, \\
A_{17} &= [\hat{D}, \hat{D}]^{(2)}, D_2^{(1)}, D_2^{(1)}/64, & A_{38} &= [C_2, \hat{D}]^{(2)}, \hat{D}^{(2)}, \hat{D}^{(1)}, \hat{H}^{(2)}/64, \\
A_{18} &= [\hat{D}, \hat{F}]^{(2)}, D_2^{(1)}/16, & A_{39} &= [\hat{D}, \hat{D}]^{(2)}, \hat{F}^{(1)}, \hat{H}^{(2)}/64, \\
A_{19} &= [\hat{D}, \hat{D}]^{(2)}, \hat{H}^{(2)}/16, & A_{40} &= [\hat{D}, \hat{D}]^{(2)}, \hat{F}^{(1)}, \hat{K}^{(2)}/64, \\
A_{20} &= [C_2, \hat{D}]^{(2)}, \hat{F}^{(2)}/16, & A_{41} &= [C_2, \hat{D}]^{(2)}, \hat{D}^{(2)}, \hat{F}^{(1)}, D_2^{(1)}/64, \\
A_{21} &= [\hat{D}, \hat{D}]^{(2)}, \hat{K}^{(2)}/16, & A_{42} &= [\hat{D}, \hat{F}]^{(2)}, \hat{F}^{(1)}, D_2^{(1)}/16.
\end{aligned}$$

In the above list, the bracket “[” is used in order to avoid placing the otherwise necessary up to five parentheses “(”.

Using the elements of the minimal polynomial basis given above the following affine invariant

polynomials were constructed in [16].

$$\gamma_1(\tilde{a}) = A_1^2(3A_6 + 2A_7) - 2A_6(A_8 + A_{12}),$$

$$\begin{aligned} \gamma_2(\tilde{a}) = & 9A_1^2A_2(23252A_3 + 23689A_4) - 1440A_2A_5(3A_{10} + 13A_{11}) - 1280A_{13}(2A_{17} + A_{18} \\ & + 23A_{19} - 4A_{20}) - 320A_{24}(50A_8 + 3A_{10} + 45A_{11} - 18A_{12}) + 120A_1A_6(6718A_8 \\ & + 4033A_9 + 3542A_{11} + 2786A_{12}) + 30A_1A_{15}(14980A_3 - 2029A_4 - 48266A_5) \\ & - 30A_1A_7(76626A_1^2 - 15173A_8 + 11797A_{10} + 16427A_{11} - 30153A_{12}) \\ & + 8A_2A_7(75515A_6 - 32954A_7) + 2A_2A_3(33057A_8 - 98759A_{12}) - 60480A_1^2A_{24} \\ & + A_2A_4(68605A_8 - 131816A_9 + 131073A_{10} + 129953A_{11}) - 2A_2(141267A_6^2 \\ & - 208741A_5A_{12} + 3200A_2A_{13}), \end{aligned}$$

$$\begin{aligned} \gamma_3(\tilde{a}) = & 843696A_5A_6A_{10} + A_1(-27(689078A_8 + 419172A_9 - 2907149A_{10} - 2621619A_{11})A_{13} \\ & - 26(21057A_3A_{23} + 49005A_4A_{23} - 166774A_3A_{24} + 115641A_4A_{24})). \end{aligned}$$

$$\begin{aligned} \gamma_4(\tilde{a}) = & -9A_4^2(14A_{17} + A_{21}) + A_5^2(-560A_{17} - 518A_{18} + 881A_{19} - 28A_{20} + 509A_{21}) \\ & - A_4(171A_8^2 + 3A_8(367A_9 - 107A_{10}) + 4(99A_9^2 + 93A_9A_{11} + A_5(-63A_{18} - 69A_{19} \\ & + 7A_{20} + 24A_{21}))) + 72A_{23}A_{24}, \end{aligned}$$

$$\begin{aligned} \gamma_5(\tilde{a}) = & -488A_2^3A_4 + A_2(12(4468A_8^2 + 32A_9^2 - 915A_{10}^2 + 320A_9A_{11} - 3898A_{10}A_{11} - 3331A_{11}^2 \\ & + 2A_8(78A_9 + 199A_{10} + 2433A_{11})) + 2A_5(25488A_{18} - 60259A_{19} - 16824A_{21}) \\ & + 779A_4A_{21}) + 4(7380A_{10}A_{31} - 24(A_{10} + 41A_{11})A_{33} + A_8(33453A_{31} + 19588A_{32} \\ & - 468A_{33} - 19120A_{34}) + 96A_9(-A_{33} + A_{34}) + 556A_4A_{41} - A_5(27773A_{38} + 41538A_{39} \\ & - 2304A_{41} + 5544A_{42})), \end{aligned}$$

$$\gamma_6(\tilde{a}) = 2A_{20} - 33A_{21},$$

$$\begin{aligned} \gamma_7(\tilde{a}) = & A_1(64A_3 - 541A_4)A_7 + 86A_8A_{13} + 128A_9A_{13} - 54A_{10}A_{13} - 128A_3A_{22} + 256A_5A_{22} \\ & + 101A_3A_{24} - 27A_4A_{24}, \end{aligned}$$

$$\begin{aligned} \gamma_8(\tilde{a}) = & 3063A_4A_9^2 - 42A_7^2(304A_8 + 43(A_9 - 11A_{10})) - 6A_3A_9(159A_8 + 28A_9 + 409A_{10}) \\ & + 2100A_2A_9A_{13} + 3150A_2A_7A_{16} + 24A_3^2(34A_{19} - 11A_{20}) + 840A_5^2A_{21} - 932A_2A_3A_{22} \\ & + 525A_2A_4A_{22} + 844A_{22}^2 - 630A_{13}A_{33}, \end{aligned}$$

$$\gamma_9(\tilde{a}) = 2A_8 - 6A_9 + A_{10},$$

$$\begin{aligned}
\gamma_{10}(\tilde{a}) &= 3A_8 + A_{11}, \\
\gamma_{11}(\tilde{a}) &= -5A_7A_8 + A_7A_9 + 10A_3A_{14}, \\
\gamma_{12}(\tilde{a}) &= 25A_2^2A_3 + 18A_{12}^2, \\
\gamma_{13}(\tilde{a}) &= A_2, \\
\gamma_{14}(\tilde{a}) &= A_2A_4 + 18A_2A_5 - 236A_{23} + 188A_{24}, \\
\gamma_{15}(\tilde{a}, x, y) &= 144T_1T_7^2 - T_1^3(T_{12} + 2T_{13}) - 4(T_9T_{11} + 4T_7T_{15} + 50T_3T_{23} + 2T_4T_{23} + 2T_3T_{24} + 4T_4T_{24}), \\
\gamma_{16}(\tilde{a}, x, y) &= T_{15}, \\
\gamma_{17}(\tilde{a}, x, y) &= T_{11} + 12T_{13}, \\
\tilde{\gamma}_{18}(\tilde{a}, x, y) &= C_1(C_2, C_2)^{(2)} - 2C_2(C_1, C_2)^{(2)}, \\
\tilde{\gamma}_{19}(\tilde{a}, x, y) &= D_1(C_1, C_2)^{(2)} - ((C_2, C_2)^{(2)}, C_0)^{(1)}, \\
\delta_1(\tilde{a}) &= 9A_8 + 31A_9 + 6A_{10}, \\
\delta_2(\tilde{a}) &= 41A_8 + 44A_9 + 32A_{10}, \\
\delta_3(\tilde{a}) &= 3A_{19} - 4A_{17}, \\
\delta_4(\tilde{a}) &= -5A_2A_3 + 3A_2A_4 + A_{22}, \\
\delta_5(\tilde{a}) &= 62A_8 + 102A_9 - 125A_{10}, \\
\delta_6(\tilde{a}) &= 2T_3 + 3T_4, \\
\beta_1(\tilde{a}) &= 3A_1^2 - 2A_8 - 2A_{12}, \\
\beta_2(\tilde{a}) &= 2A_7 - 9A_6, \\
\beta_3(\tilde{a}) &= A_6, \\
\beta_4(\tilde{a}) &= -5A_4 + 8A_5, \\
\beta_5(\tilde{a}) &= A_4, \\
\beta_6(\tilde{a}) &= A_1, \\
\beta_7(\tilde{a}) &= 8A_3 - 3A_4 - 4A_5, \\
\beta_8(\tilde{a}) &= 24A_3 + 11A_4 + 20A_5, \\
\beta_9(\tilde{a}) &= -8A_3 + 11A_4 + 4A_5, \\
\beta_{10}(\tilde{a}) &= 8A_3 + 27A_4 - 54A_5, \\
\beta_{11}(\tilde{a}, x, y) &= T_1^2 - 20T_3 - 8T_4, \\
\beta_{12}(\tilde{a}, x, y) &= T_1, \\
\beta_{13}(\tilde{a}, x, y) &= T_3, \\
\mathcal{R}_1(\tilde{a}) &= -2A_7(12A_1^2 + A_8 + A_{12}) + 5A_6(A_{10} + A_{11}) - 2A_1(A_{23} - A_{24}) + 2A_5(A_{14} + A_{15}) \\
&\quad + A_6(9A_8 + 7A_{12}), \\
\mathcal{R}_2(\tilde{a}) &= A_8 + A_9 - 2A_{10}, \\
\mathcal{R}_3(\tilde{a}) &= A_9, \\
\mathcal{R}_4(\tilde{a}) &= -3A_1^2A_{11} + 4A_4A_{19},
\end{aligned}$$

$$\begin{aligned}
\mathcal{R}_5(\tilde{a}, x, y) &= (2C_0(T_8 - 8T_9 - 2D_2^2) + C_1(6T_7 - T_6) - (C_1, T_5)^{(1)} + 6D_1(C_1D_2 - T_5) - 9D_1^2C_2), \\
\mathcal{R}_6(\tilde{a}) &= -213A_2A_6 + A_1(2057A_8 - 1264A_9 + 677A_{10} + 1107A_{12}) + 746(A_{27} - A_{28}), \\
\mathcal{R}_7(\tilde{a}) &= -6A_7^2 - A_4A_8 + 2A_3A_9 - 5A_4A_9 + 4A_4A_{10} - 2A_2A_{13}, \\
\mathcal{R}_8(\tilde{a}) &= A_{10}, \\
\mathcal{R}_9(\tilde{a}) &= -5A_8 + 3A_9, \\
\mathcal{R}_{10}(\tilde{a}) &= 7A_8 + 5A_{10} + 11A_{11}, \\
\mathcal{R}_{11}(\tilde{a}, x, y) &= T_{16}. \\
\chi_A^{(1)}(\tilde{a}) &= A_6(A_1A_2 - 2A_{15})(3A_1^2 - 2A_8 - 2A_{12}), \\
\chi_B^{(1)}(\tilde{a}) &= A_7[41A_1A_2A_3 + 846A_6A_9 - 252A_6A_{10} + 3798A_6A_{11} - 2A_7(6588A_1^2 - 830A_8 + 265A_{10} \\
&\quad + 366A_{11} - 156A_{12}) + 1098A_6A_{12} + 983A_3A_{14} - 1548A_4A_{14} - 365A_3A_{15} + 1350A_4A_{15} \\
&\quad + 1550A_2A_{16} - 1350A_1A_{23}], \\
\chi_C^{(1)}(\tilde{a}) &= \theta\beta_1\beta_3[8A_1(42A_{23} - 24A_2A_3 + 59A_2A_5) + A_6(2196A_1^2 + 384A_9 + 24A_{10} + 360A_{11} \\
&\quad - 432A_{12}) + 4A_7(123A_8 - 61A_{10} - 23A_{11} + 123A_{12}) + 8(2A_4A_{14} - 34A_5A_{15} - 19A_2A_{16})], \\
\tilde{\chi}_D^{(1)}(\tilde{a}) &= -378A_1^2 + 213A_8 + 40A_9 - 187A_{10} - 205A_{11} + 317A_{12}, \\
\chi_E^{(1)}(\tilde{a}) &= 48A_6(65A_9 - 54A_{10} - 27A_{11}) - 16A_7(774A_1^2 - 382A_8 + 263A_{10} + 129A_{11} - 360A_{12}) \\
&\quad + 72A_4(23A_{14} + 3A_{15}) - 16A_3(163A_{14} + 185A_{15}) - 1792A_2A_{16} + 16A_1(54A_2A_5 \\
&\quad - 173A_{22} + 27A_{24}), \\
\chi_F^{(1)}(\tilde{a}) &= \theta\beta_1\beta_3[A_7(2A_5 - A_4) - 2A_3A_6], \\
\chi_G^{(1)}(\tilde{a}) &= 12A_3 - 7A_4, \\
\chi_A^{(2)}(\tilde{a}) &= A_4(5A_8 - 18A_1^2 - A_{10} - 3A_{11} + 9A_{12}), \\
\chi_B^{(2)}(\tilde{a}) &= A_3(2A_8 - 6A_1^2 - A_9 + A_{10} - A_{11} + 3A_{12}), \\
\chi_A^{(3)}(\tilde{a}) &= 49071656765835A_1^6 + 27A_1^4(1344257279043A_{11} - 1270094588593A_{12}) \\
&\quad + 3A_1^2(176071859457A_2^2A_4 + 2042424190056A_{11}^2 - 4553853105234A_{11}A_{12} \\
&\quad + 2056276619466A_{12}^2 + 221071597034A_5A_{18} - 539155411551A_5A_{19} \\
&\quad + 65833344676A_5A_{20} + 26464141896A_4A_{21} + 303070135713A_5A_{21} \\
&\quad - 137515925820A_2A_{23}) + 1048(35846142A_2^2A_4A_{11} - 163576560A_{11}^3 - 21276288A_2^2A_4A_{12} \\
&\quad - 195478380A_{11}^2A_{12} + 325223640A_{11}A_{12}^2 - 93862680A_{12}^3 + 782460A_4A_8A_{20} \\
&\quad + 26186136A_2A_8A_{22} + 42548200A_2A_9A_{22} - 2682720A_5^2A_{29} - 83946780A_2A_5A_{31} \\
&\quad + 429178020A_2A_5A_{32} - 204768603A_2A_4A_{34} - 125823390A_2A_5A_{34}),
\end{aligned}$$

$$\begin{aligned}
\chi_B^{(3)}(\tilde{a}) = & 10687627614087A_1^6 - 36A_1^2A_{11}(57734730901A_{11} - 18520980346A_{12}) \\
& - 54A_1^4(29889576561A_{11} + 85579885241A_{12}) - 1848441298229A_4A_8A_{19} \\
& - 995417129104A_4A_{10}A_{19} + 139152650610A_5A_{10}A_{19} - 854619791782A_4A_{11}A_{19} \\
& - 234092667978A_5A_{11}A_{19} - 1064773031314A_4A_{12}A_{19} - 1538921088774A_5A_{12}A_{19} \\
& - 200109956062A_4A_8A_{20} - 33399158264A_4A_{10}A_{20} + 1182168636A_5A_{10}A_{20} \\
& - 33699561192A_4A_{11}A_{20} + 359794764A_5A_{11}A_{20} - 150658987068A_4A_{12}A_{20} \\
& - 97478758260A_5A_{12}A_{20} - 1043930677997A_4A_8A_{21} - 381285679090A_4A_{10}A_{21} \\
& - 266080146306A_5A_{10}A_{21} - 340140897016A_4A_{11}A_{21} - 373227206190A_5A_{11}A_{21} \\
& - 763104633190A_4A_{12}A_{21} - 470713035534A_5A_{12}A_{21},
\end{aligned}$$

$$\begin{aligned}
\chi_C^{(3)}(\tilde{a}) = & -(30838311945A_1^2A_2^2A_4 + 2760800121876A_1^2A_8^2 + 7697984307234A_1^2A_8A_9 \\
& + 3201113344320A_1^2A_9^2 - 1697507613684A_1^2A_8A_{10} + 31825111584A_2^2A_4A_{11} \\
& - 695990880A_1^2A_8A_{11} - 61410960A_1^2A_{11}^2 + 10245847104A_2^2A_4A_{12} \\
& - 24350953680A_4A_8A_{17} - 2913648480A_4A_9A_{17} - 2523363762580A_1^2A_5A_{18} \\
& - 29706323760A_4A_8A_{18} + 334082073870A_1^2A_5A_{19} + 142776946840A_1^2A_5A_{20} \\
& + 47764080A_4A_8A_{20} + 282210480A_1^2A_4A_{21} + 2047601391150A_1^2A_5A_{21} \\
& + 63016473792A_2A_8A_{22} + 77305513600A_2A_9A_{22} - 35441430120A_1^2A_2A_{23} \\
& - 42056705280A_2A_9A_{23} - 163762560A_5^2A_{29} - 94243374720A_2A_5A_{31} \\
& + 290822854080A_2A_5A_{32} - 150861290016A_2A_4A_{34} - 47162628000A_2A_5A_{34}),
\end{aligned}$$

$$\begin{aligned}
\chi_D^{(3)}(\tilde{a}) = & (7815A_2^2A_4^2 - 1912260A_4A_8^2 - 3772362A_4A_8A_9 - 237900A_4A_8A_{10} - 178080A_2A_{10}A_{13} \\
& - 193248A_2A_{11}A_{13} - 1318176A_5^2A_{17} + 1194740A_4A_5A_{18} - 139104A_5^2A_{18} \\
& + 56706A_4A_5A_{19} + 702144A_5^2A_{19} - 56552A_4A_5A_{20} - 11040A_4^2A_{21} - 995070A_4A_5A_{21} \\
& - 32856A_2A_4A_{23} + 26112A_2A_5A_{24}),
\end{aligned}$$

$$\chi_E^{(3)}(\tilde{a}) = 54A_1^2A_2 + 611A_2A_9 - 104A_2A_{11} - 140A_2A_{12} + 732A_1A_{14} - 243A_{31} - 234A_{33} + 245A_{34},$$

$$\chi_F^{(3)}(\tilde{a}) = -(11A_4 + 10A_5),$$

$$\begin{aligned}
\chi_A^{(4)}(\tilde{a}) = & (-2A_2^2A_4 - 80A_8^2 + 64A_8A_9 - 80A_8A_{10} + 16A_9A_{10} - 9A_{10}^2 - 32A_8A_{11} + 48A_9A_{11} \\
& + 2A_{10}A_{11} + 23A_{11}^2 + 120A_5A_{17} + 24A_5A_{18} - 4A_5A_{19} + 6A_4A_{21} + 4A_5A_{21}) \\
& \times (264A_2^2A_8 - 112A_2^2A_9 - 56A_9A_{17} + 746A_{10}A_{17} + 1006A_{11}A_{17} + 424A_{10}A_{18} \\
& + 824A_{11}A_{18} + 1092A_8A_{19} - 384A_9A_{19} - 97A_{10}A_{19} + 153A_{11}A_{19} - 264A_8A_{20} \\
& + 168A_9A_{20} + 14A_{10}A_{20} - 14A_{11}A_{20} - 620A_8A_{21} + 81A_{10}A_{21} - 81A_{11}A_{21} \\
& + 126A_4A_{30} - 208A_2A_{31} - 112A_2A_{33}),
\end{aligned}$$

$$\begin{aligned}
\chi_B^{(4)}(\tilde{a}) &= (-12(518A_8^2 - 16A_9(2A_{10} + 5A_{11})) + 2(A_{10} + 3A_{11})(31A_{10} + 69A_{11}) + A_8(369A_{10} \\
&\quad + 871A_{11}) - 96A_3A_{17}) + 2A_5(552A_2^2 - 404A_{18} + 2271A_{19} - 316A_{20} - 1674A_{21}) \\
&\quad - 135A_4A_{21} - 240A_2A_{23})(4A_2^2(6160A_9 - 60659A_{10} + 5565A_{11}) + 533574A_{10}A_{17} \\
&\quad + 2120070A_{11}A_{17} + 365744A_{10}A_{18} + 657528A_{11}A_{18} - 713634A_{10}A_{19} + 8A_9(22484A_{17} \\
&\quad + 10472A_{18} + 10911A_{19} - 2156A_{20}) + 121318A_{10}A_{20} - 11130A_{11}A_{20} + 522591A_{10}A_{21} \\
&\quad - 357309A_{11}A_{21} + 72A_8(13247A_{17} + 1081A_{20} + 7084A_{21}) + 2079A_4A_{30} + 186520A_2A_{34}), \\
\chi_A^{(5)}(\tilde{a}) &= 95A_9 + 2A_{10}, \\
\chi_A^{(6)}(\tilde{a}) &= 4A_{11} - 4A_{10}, \\
\chi_B^{(6)}(\tilde{a}) &= (A_4 - 2A_5)(A_8 - 2A_{11}), \\
\chi_A^{(7)}(\tilde{a}) &= (A_3 - A_4)(A_8 - A_{10}), \\
\chi_B^{(7)}(\tilde{a}) &= -2A_8(6348A_9^2 - A_4(502073A_{18} + 250407A_{19} + 37072A_{20}) + 18A_2(720A_{22} + 8179A_{23})) \\
&\quad + 3(640A_9^3 + 36A_7^2(3218A_{18} + 17721A_{19}) + 8A_9(7505A_4A_{18} + 37966A_2A_{23}) + 4A_2(A_{13} \\
&\quad \times (74429A_{18} + 44574A_{19}) - 7A_{10}(5387A_{22} + 4741A_{23}) + 243552A_7A_{27}) \\
&\quad + A_4(-341504A_{10}A_{18} - 78779A_7A_{25} + 234046A_2A_{33})), \\
\chi_C^{(7)}(\tilde{a}) &= 2484A_7^2(2A_{18} + 9A_{19}) - 2A_8(276A_9^2 + A_4(-34111A_{18} + 51231A_{19} - 35504A_{20}) \\
&\quad + 46794A_2A_{23}) + 3(4A_2(5403A_{13}A_{18} - 29222A_{13}A_{19} - 6123A_{10}A_{22} + 11444A_9A_{23} \\
&\quad + 7131A_{10}A_{23} + 41384A_7A_{27}) + A_4(1080A_9A_{18} - 35328A_{10}A_{18} - 52173A_7A_{25} \\
&\quad + 35842A_2A_{33})), \\
\chi_D^{(7)}(\tilde{a}) &= (A_3 - A_4)(8A_7^2 - 44A_3A_8 + 27A_4A_8 + 4A_3A_9 + 22A_3A_{10} - 9A_4A_{10}), \\
\chi_F^{(7)}(\tilde{a}) &= 24A_8 - 23A_{10}, \\
\chi_A^{(8)}(\tilde{a}) &= 5A_8 - A_9, \\
\chi_D^{(8)}(\tilde{a}) &= 9A_9 - 25A_8.
\end{aligned}$$

We also need here the following additional affine invariant polynomials, constructed in [28]:

$$\begin{aligned}
H_2 &= -[(C_1, 8\hat{H} + \hat{N})^{(1)} + 2D_1\hat{N}], \quad H_9 = -[\hat{D}, \hat{D}]^{(2)}, \hat{D}^{(1)}, \hat{D}^{(3)} \equiv 12\mathbf{D}, \\
H_{10} &= -[\hat{D}, \hat{N}]^{(2)}, D_2^{(1)}, \quad H_{11} = 3[(C_1, 8\hat{H} + \hat{N})^{(1)} + 2D_1\hat{N}]^2 - 32\hat{H}[(C_2, \hat{D})^{(2)} + (\hat{D}, D_2)^{(1)}], \\
H_{12} &= (\hat{D}, \hat{D})^{(2)}, \quad N_7 = 12D_1(C_0, D_2)^{(1)} + 2D_1^3 + 9D_1(C_1, C_2)^{(2)} + 36[C_0, C_1]^{(1)}, D_2^{(1)},
\end{aligned}$$

Next we construct the following T -comitants (for the definition of T -comitants see [25]) which are responsible for the existence of invariant straight lines of systems (3):

Notation 1.

$$\begin{aligned}
B_3(a, x, y) &= (C_2, D)^{(1)} = \text{Jacob}(C_2, D), \\
B_2(a, x, y) &= (B_3, B_3)^{(2)} - 6B_3(C_2, D)^{(3)}, \\
B_1(a) &= \text{Res}_x(C_2, D) / y^9 = -2^{-9}3^{-8}(B_2, B_3)^{(4)}.
\end{aligned} \tag{7}$$

Lemma 2 (see [24]). *For the existence of invariant straight lines in one (respectively 2; 3 distinct) directions in the affine plane it is necessary that $B_1 = 0$ (respectively $B_2 = 0$; $B_3 = 0$).*

At the moment we only have necessary and not necessary and sufficient conditions for the existence of an invariant straight line or for invariant lines in two or three directions.

Let us apply a translation $x = x' + x_0$, $y = y' + y_0$ to the polynomials $p(\tilde{a}, x, y)$ and $q(\tilde{a}, x, y)$. We obtain $\hat{p}(\hat{a}(a, x_0, y_0), x', y') = p(\tilde{a}, x' + x_0, y' + y_0)$, $\hat{q}(\hat{a}(a, x_0, y_0), x', y') = q(\tilde{a}, x' + x_0, y' + y_0)$. Let us construct the following polynomials

$$\Gamma_i(\tilde{a}, x_0, y_0) \equiv \text{Res}_{x'} \left(C_i(\hat{a}(\tilde{a}, x_0, y_0), x', y'), C_0(\hat{a}(\tilde{a}, x_0, y_0), x', y') \right) / (y')^{i+1},$$

$$\Gamma_i(\tilde{a}, x_0, y_0) \in \mathbb{R}[\tilde{a}, x_0, y_0], \quad i = 1, 2.$$

Notation 2. We denote by

$$\tilde{\mathcal{E}}_i(\tilde{a}, x, y) = \Gamma_i(\tilde{a}, x_0, y_0)|_{\{x_0=x, y_0=y\}} \in \mathbb{R}[\tilde{a}, x, y] \quad (i = 1, 2).$$

Observation 1. We note that the polynomials $\tilde{\mathcal{E}}_1(a, x, y)$ and $\tilde{\mathcal{E}}_2(a, x, y)$ are affine comitants of systems (3) and are homogeneous polynomials in the coefficients $a, b, c, d, e, f, g, h, k, l, m, n$ and non-homogeneous in x, y and $\deg_{\tilde{a}} \tilde{\mathcal{E}}_1 = 3$, $\deg_{(x,y)} \tilde{\mathcal{E}}_1 = 5$, $\deg_{\tilde{a}} \tilde{\mathcal{E}}_2 = 4$, $\deg_{(x,y)} \tilde{\mathcal{E}}_2 = 6$.

Notation 3. Let $\mathcal{E}_i(\tilde{a}, X, Y, Z)$, $i = 1, 2$, be the homogenization of $\tilde{\mathcal{E}}_i(\tilde{a}, x, y)$, i.e.

$$\mathcal{E}_1(\tilde{a}, X, Y, Z) = Z^5 \tilde{\mathcal{E}}_1(\tilde{a}, X/Z, Y/Z), \quad \mathcal{E}_2(\tilde{a}, X, Y, Z) = Z^6 \tilde{\mathcal{E}}_2(\tilde{a}, X/Z, Y/Z)$$

The geometrical meaning of these affine comitants is given by the following lemma (see [24]):

Lemma 3 (see [24]). 1) The straight line $\mathcal{L}(x, y) \equiv ux + vy + w = 0$, $u, v, w \in \mathbb{C}$, $(u, v) \neq (0, 0)$ is an invariant line for a quadratic system (3) if and only if the polynomial $\mathcal{L}(x, y)$ is a common factor of the polynomials $\tilde{\mathcal{E}}_1(\tilde{a}, x, y)$ and $\tilde{\mathcal{E}}_2(\tilde{a}, x, y)$ over \mathbb{C} , i.e.

$$\tilde{\mathcal{E}}_i(\tilde{a}, x, y) = (ux + vy + w) \widetilde{W}_i(x, y), \quad i = 1, 2,$$

where $\widetilde{W}_i(x, y) \in \mathbb{C}[x, y]$.

2) If $\mathcal{L}(x, y) = 0$ is an invariant straight line of multiplicity λ for a quadratic system (3), then $[\mathcal{L}(x, y)]^\lambda \mid \text{gcd}(\tilde{\mathcal{E}}_1, \tilde{\mathcal{E}}_2)$ in $\mathbb{C}[x, y]$, i.e. there exist $W_i(\tilde{a}, x, y) \in \mathbb{C}[x, y]$, $i = 1, 2$, such that

$$\tilde{\mathcal{E}}_i(\tilde{a}, x, y) = (ux + vy + w)^\lambda W_i(\tilde{a}, x, y), \quad i = 1, 2.$$

3) If the line $l_\infty : Z = 0$ is of multiplicity $\lambda > 1$, then $Z^{\lambda-1} \mid \text{gcd}(\mathcal{E}_1, \mathcal{E}_2)$.

In order to detect the parallel invariant lines we need the following invariant polynomials:

$$N(\tilde{a}, x, y) = D_2^2 + T_8 - 2T_9 = 9\widehat{N}, \quad \theta(\tilde{a}) = 2A_5 - A_4 \quad (\equiv \text{Discriminant}(N(a, x, y))/1296).$$

Lemma 4 (see [24]). A necessary condition for the existence of one couple (respectively two couples) of parallel invariant straight lines of a system (3) corresponding to $\tilde{a} \in \mathbb{R}^{12}$ is the condition $\theta(\tilde{a}) = 0$ (respectively $N(\tilde{a}, x, y) = 0$).

Now we introduce some important GL -comitant in the study of the invariant conics. Considering $C_2(\tilde{a}, x, y) = yp_2(\tilde{a}, x, y) - xq_2(\tilde{a}, x, y)$ as a cubic binary form of x and y we calculate

$$\eta(\tilde{a}) = \text{Discrim}[C_2, \xi], \quad M(\tilde{a}, x, y) = \text{Hessian}[C_2],$$

where $\xi = y/x$ or $\xi = x/y$. According to [30] we have the next result.

Lemma 5 ([30]). *The number of infinite singularities (real and imaginary) of a quadratic system in \mathbf{QS} is determined by the following conditions:*

- (i) 3 real if $\eta > 0$;
- (ii) 1 real and 2 imaginary if $\eta < 0$;
- (iii) 2 real if $\eta = 0$ and $M \neq 0$;
- (iv) 1 real if $\eta = M = 0$ and $C_2 \neq 0$;
- (v) ∞ if $\eta = M = C_2 = 0$.

Moreover, for each one of these cases the quadratic systems (3) can be brought via a linear transformation to one of the following canonical systems $(\mathbf{S}_I) - (\mathbf{S}_V)$:

$$\begin{cases} \dot{x} = a + cx + dy + gx^2 + (h-1)xy, \\ \dot{y} = b + ex + fy + (g-1)xy + hy^2; \end{cases} \quad (\mathbf{S}_I)$$

$$\begin{cases} \dot{x} = a + cx + dy + gx^2 + (h+1)xy, \\ \dot{y} = b + ex + fy - x^2 + gxy + hy^2; \end{cases} \quad (\mathbf{S}_{II})$$

$$\begin{cases} \dot{x} = a + cx + dy + gx^2 + hxy, \\ \dot{y} = b + ex + fy + (g-1)xy + hy^2; \end{cases} \quad (\mathbf{S}_{III})$$

$$\begin{cases} \dot{x} = a + cx + dy + gx^2 + hxy, \\ \dot{y} = b + ex + fy - x^2 + gxy + hy^2; \end{cases} \quad (\mathbf{S}_{IV})$$

$$\begin{cases} \dot{x} = a + cx + dy + x^2, \\ \dot{y} = b + ex + fy + xy. \end{cases} \quad (\mathbf{S}_V)$$

Finally, in order to detect if an invariant conic

$$\Phi(x, y) \equiv p + qx + ry + sx^2 + 2txy + uy^2 = 0 \quad (8)$$

(or an invariant line) of a system (3) has the multiplicity greater than one, we use the notion of k -th extactic curve $\mathcal{E}_k(X)$ of the vector field X (see (2)), associated to systems (3). This curve is defined in the paper [7, Definition 5.1] as follows:

$$\mathcal{E}_k(X) = \det \begin{pmatrix} v_1 & v_2 & \dots & v_l \\ X(v_1) & X(v_2) & \dots & X(v_l) \\ \vdots & \vdots & \dots & \vdots \\ X^{l-1}(v_1) & X^{l-1}(v_2) & \dots & X^{l-1}(v_l) \end{pmatrix},$$

where v_1, v_2, \dots, v_l is the basis of the \mathbb{C} -vector space $\mathbb{C}_n[x, y]$ which is the set of all polynomials in x, y of degree n , of polynomials in $\mathbb{C}_n[x, y]$ and $l = (k+1)(k+2)/2$. Here $X^0(v_i) = v_i$ and $X^j(v_1) = X(X^{j-1}(v_1))$.

According to [7] the following statement holds:

Lemma 6. *Assume that an algebraic curve $\Phi(x, y) = 0$ of degree k is an invariant curve for systems (3). Then this curve has multiplicity m if and only if $\Phi(x, y)^m$ divides $\mathcal{E}_k(X)$.*

3 The configurations of invariant hyperbolas for the class $\text{QSH}_{(\eta>0)}$

In this section systems we consider systems in $\text{QSH}_{(\eta>0)}$ for which we have the following result.

Theorem 5. *Consider the class $\text{QSH}_{(\eta>0)}$ of all non-degenerate quadratic differential systems (3) possessing three distinct real singularities at infinity.*

(A) *This family is classified according to the configurations of invariant hyperbolas and of invariant straight lines of the systems, yielding 162 distinct such configurations. This geometric classification appears in DIAGRAMS 3 to 9. More precisely:*

(A₁) *There are exactly 3 configurations of systems possessing an infinite number of hyperbolas.*

(A₂) *The remaining 159 configurations could have up to a maximum of 3 distinct invariant hyperbolas, real or complex, and up to 4 distinct invariant straight lines, real or complex, including the line at infinity.*

(B) *The bifurcation diagrams for systems in $\text{QSH}_{(\eta>0)}$ done in the coefficient space \mathbb{R}^{12} in terms of invariant polynomials appear in DIAGRAMS 10 and 11. In these diagrams we have necessary and sufficient conditions for the realization of each one of the configurations.*

Remark 5. *The invariant polynomials $\chi_W^{(i)}$ in DIAGRAMS 10 and 11, where $W = A, \dots, G$ and $i = 1, \dots, 8$, as well as other invariant polynomials ($\eta, \theta, \mu_i, \beta_j \dots$ and so on) are introduced in Section 2. Moreover, in these diagrams we denote by (\mathfrak{C}_i) ($i = 1, 2, 3$) the following sets of conditions*

$$(\mathfrak{C}_1) : (\beta_2 \mathcal{R}_1 \neq 0) \cup (\beta_2 = \gamma_3 = 0 \cap \beta_3 \neq 0),$$

$$(\mathfrak{C}_2) : (\beta_4 \beta_5 \mathcal{R}_2 \neq 0) \cup (\beta_4 = \gamma_3 = 0, \mathcal{R}_2 \neq 0),$$

$$(\mathfrak{C}_3) : (\beta_1 = 0) \cap ((\gamma_{12} = 0, \mathcal{R}_9 \neq 0) \cup (\gamma_{13} = 0)).$$

Remark 6. *For more details about the geometric classification of the configurations of systems in $\text{QSH}_{(\eta>0)}$ see Section 5.*

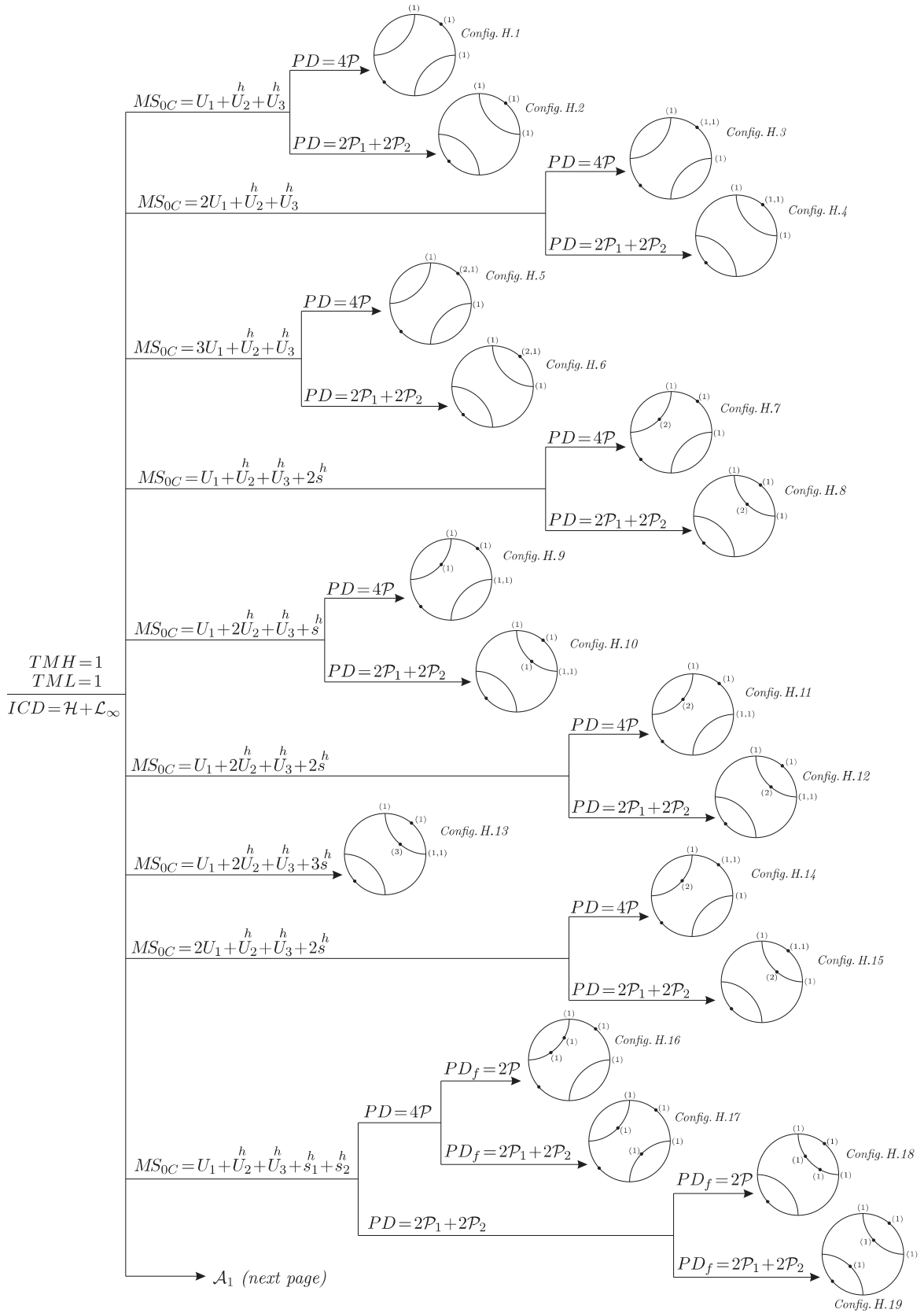

DIAGRAM 3: Diagram of configurations with one hyperbola and $TML = 1$

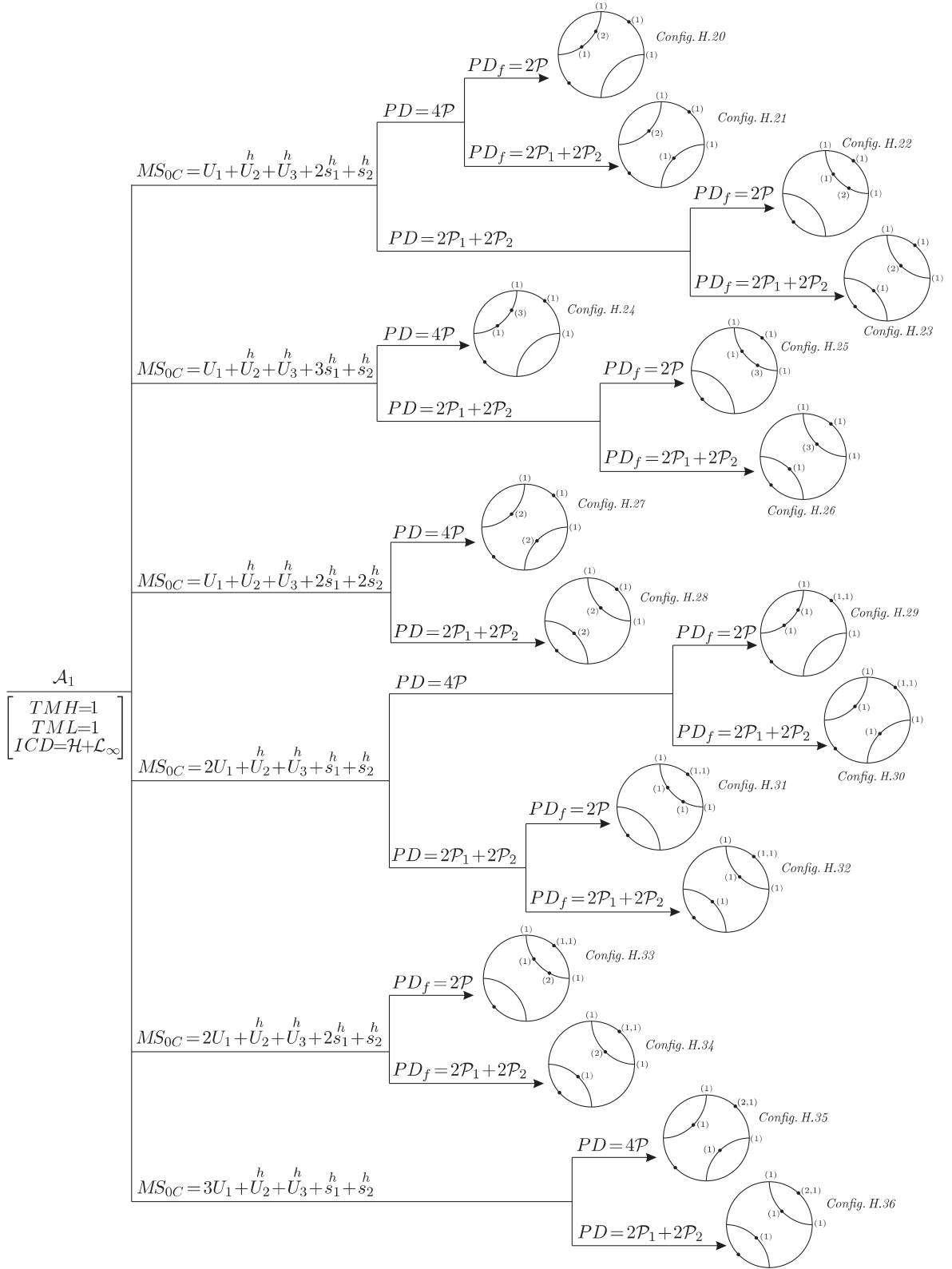

DIAGRAM 3: (Cont.) Diagram of configurations with one hyperbola and $TMH = 1$

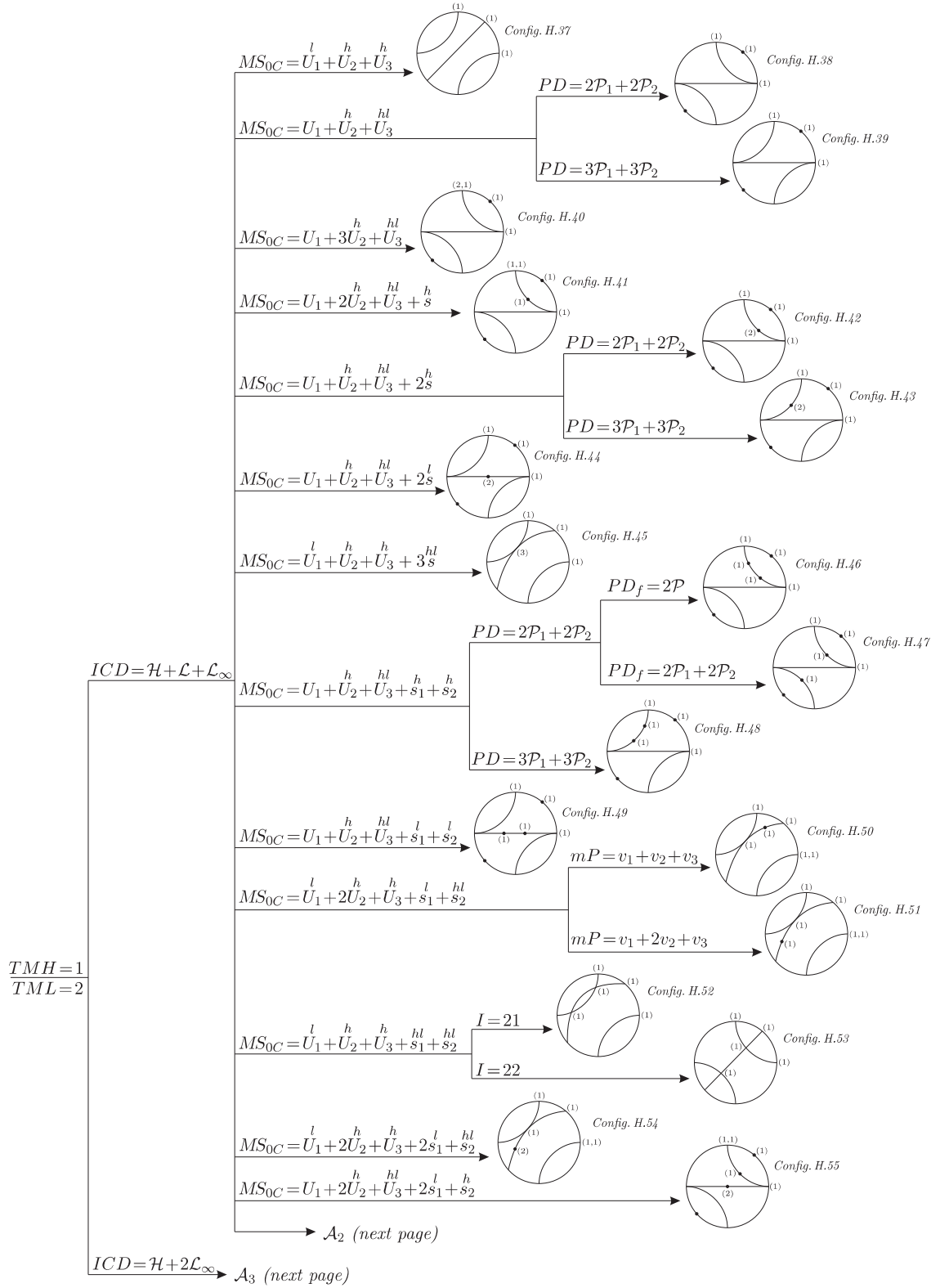

DIAGRAM 4: Diagram of configurations with one hyperbola and $TML = 2$

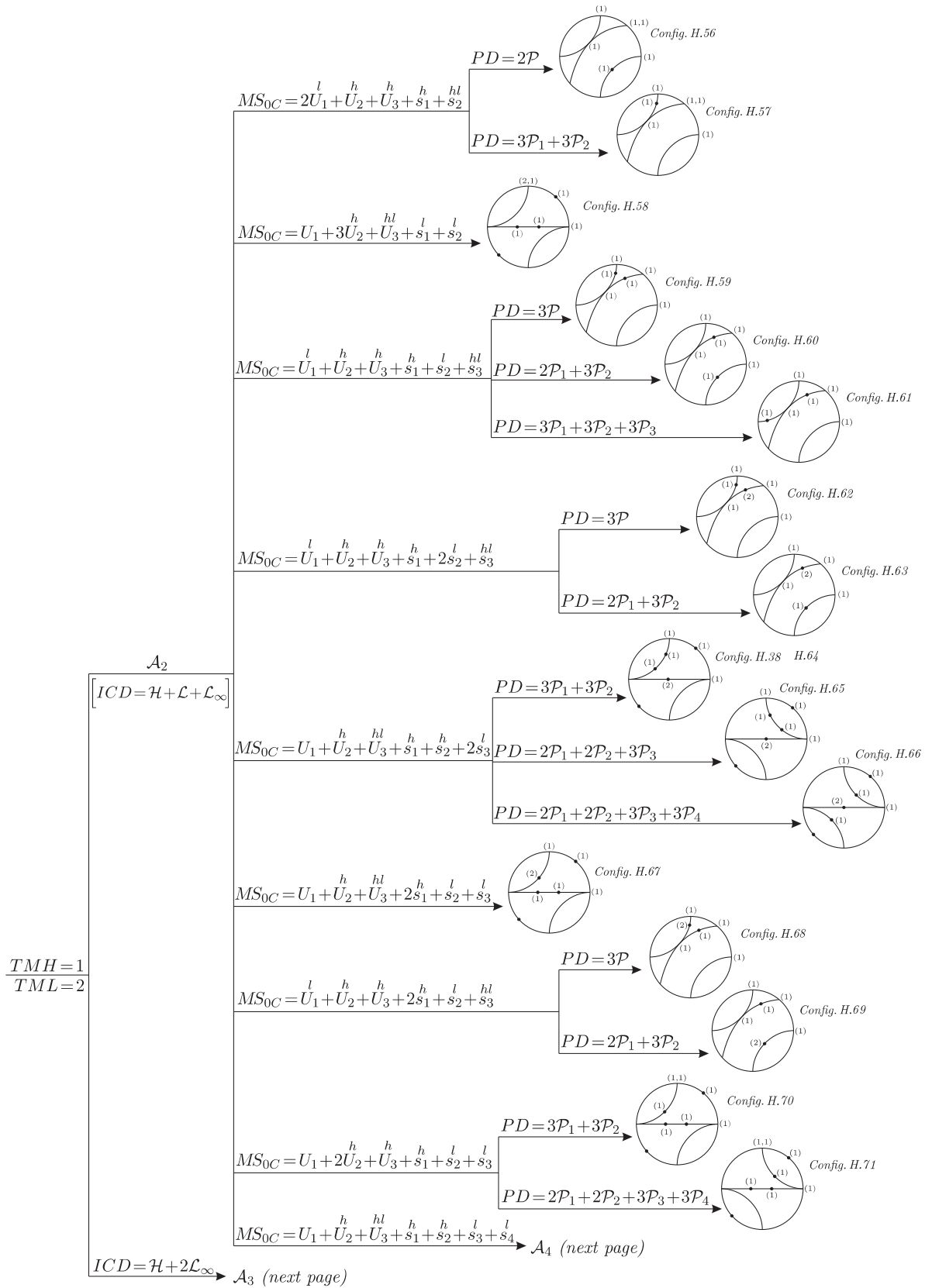

DIAGRAM 4: (Cont.) Diagram of configurations with one hyperbola and $TML = 2$

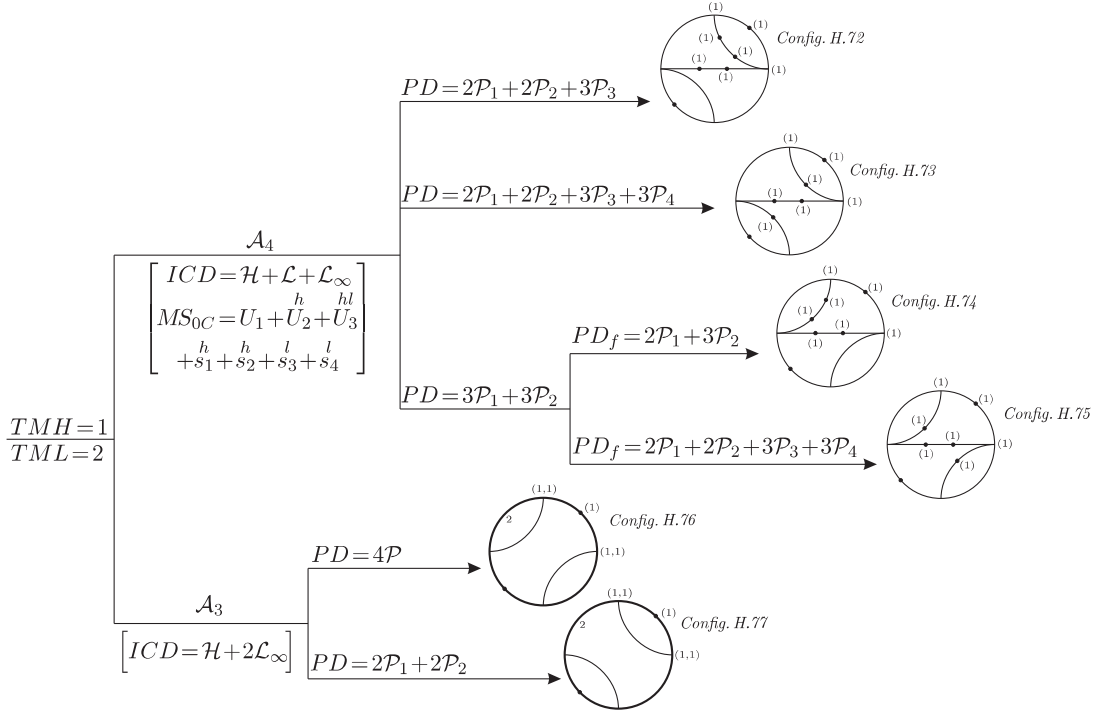

DIAGRAM 4: (Cont.) **Diagram of configurations with one hyperbola and $TML = 2$**

Proof: We prove part (A) under the assumption that part (B) is already proved. Later, we prove part (B).

We first need to make sure that the concepts introduced above gave us a sufficient number of invariants under the action of the affine group and time rescaling so as to be able to classify geometrically the class $\mathbf{QSH}_{(\eta>0)}$ according to their configurations of their invariant hyperbolas and lines. Summing up all the concepts introduced, we end up with the list: ICD , MS_{0C} , TMH , TML , PD , PD_f , PD_∞ , mP , I . From this list we clearly have that TMH and TML are invariants under the group action because the action conserves lines and the type of a conic as well as parallelism and it conserves singularities of the systems which are simple points on an invariant curve. The types of the divisor ICD on $P_2(\mathbb{C})$ and of the zero-cycle MS_{0C} on $P_2(\mathbb{R})$ are invariants under the group because the group conserves the multiplicities of the invariant curves as well as the multiplicities of the singularities. The number of vertices of a basic polygon is conserved under the group action basically because the number of intersection points of the various invariant curves is conserved. Furthermore the coefficients of mP are also conserved because multiplicities of the singularities are conserved. For analogous reasons the coefficients of PD , PD_f , PD_∞ are also conserved. The invariant I is also conserved because complex intersection points of a line with a hyperbola as well as intersection multiplicities are conserved. The concepts involved above yield all the invariants we need and we now prove that the 162 configurations obtained in this section are distinct.

Fixing the values of TMH and TML , we first apply the main divisor ICD . In many cases, just using the invariants contained in ICD and the zero-cycle MS_{0C} (TMH , TML and the corresponding types) suffice for distinguishing the configurations in a group of configurations. In other cases more invariants are needed and we introduce the necessary additional invariants, to distinguish the

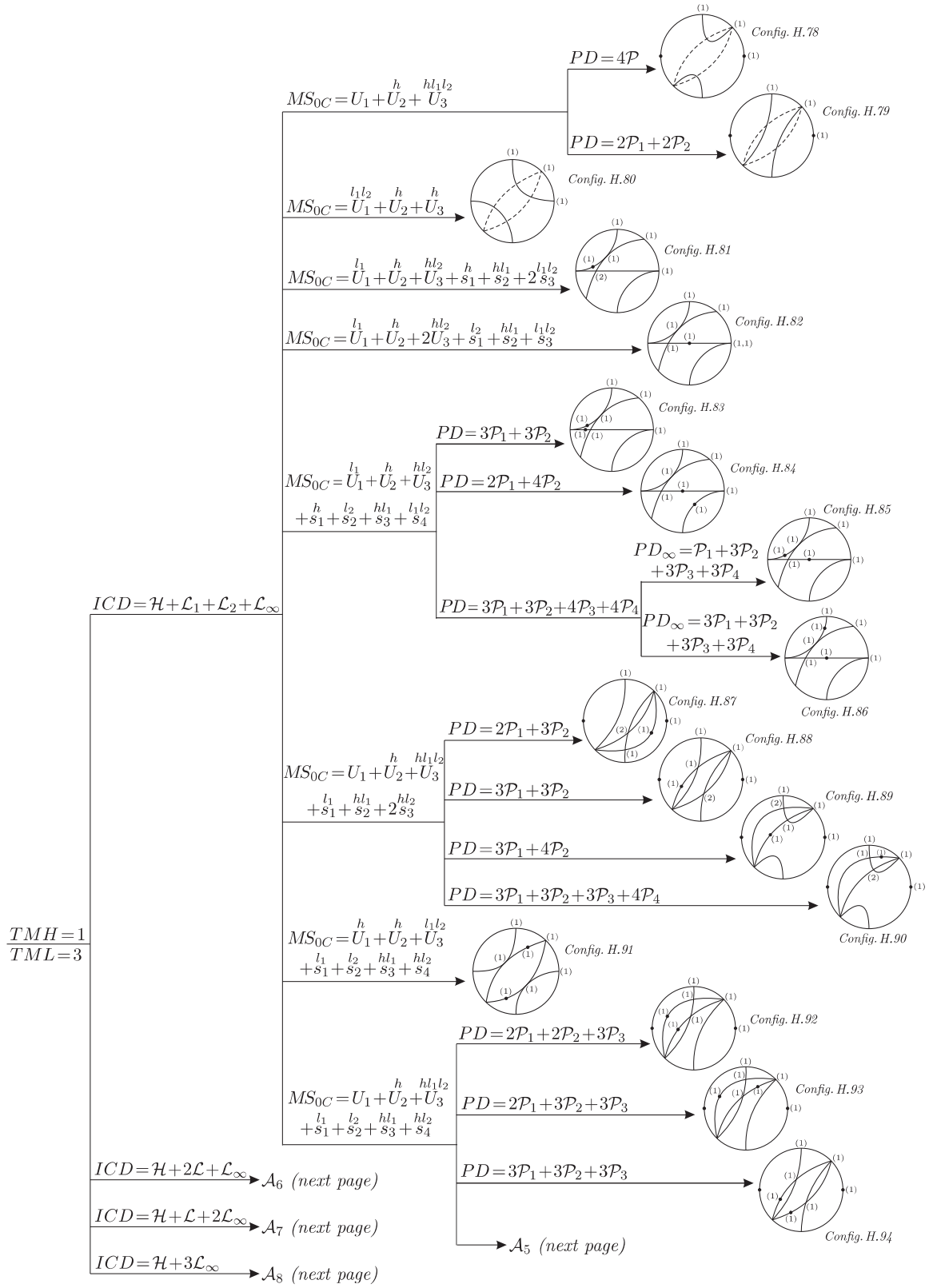

DIAGRAM 5: Diagram of configurations with one hyperbola and $TML = 3$

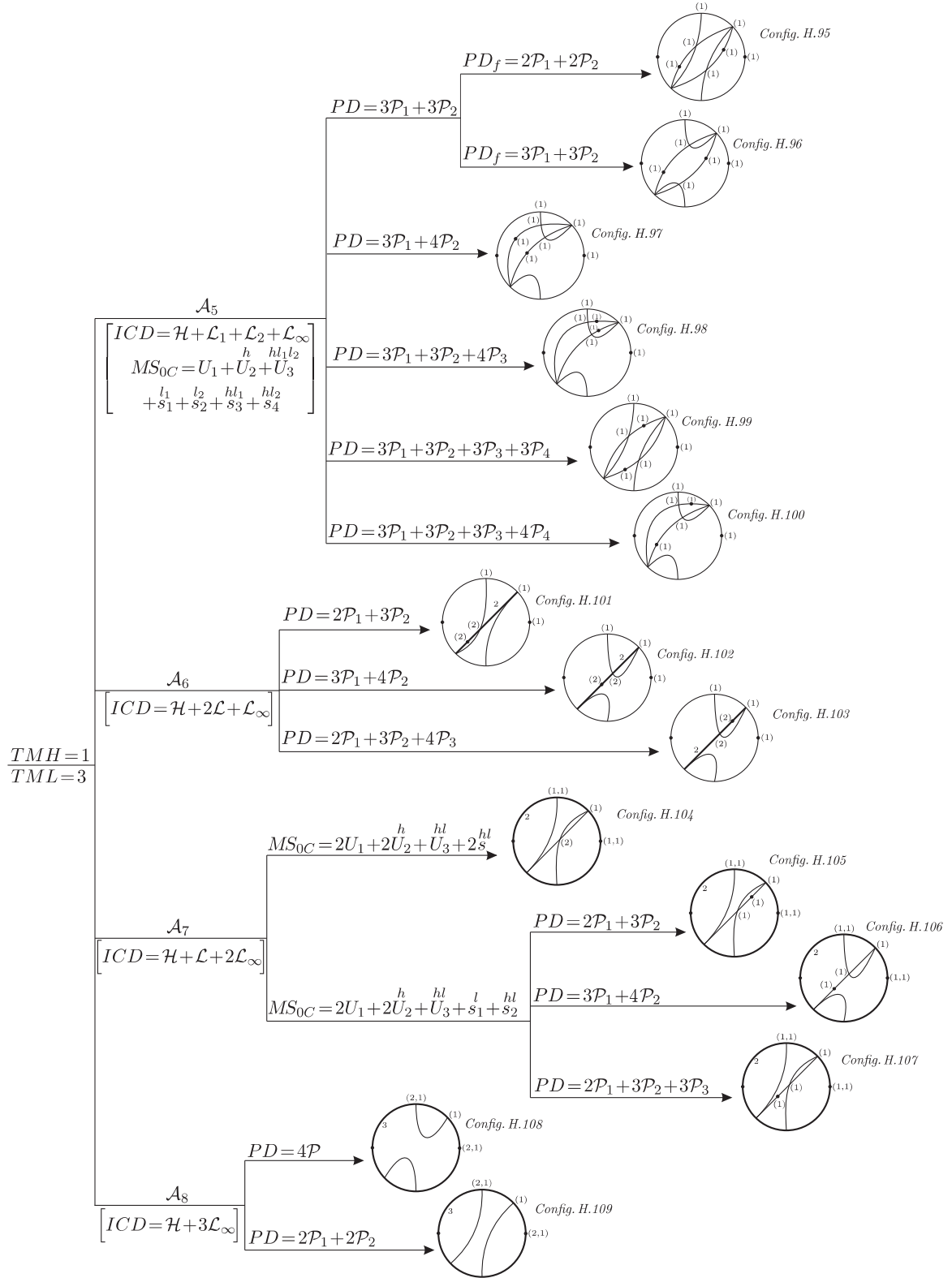

DIAGRAM 5: (Cont.) Diagram of configurations with one hyperbola and $TML = 3$

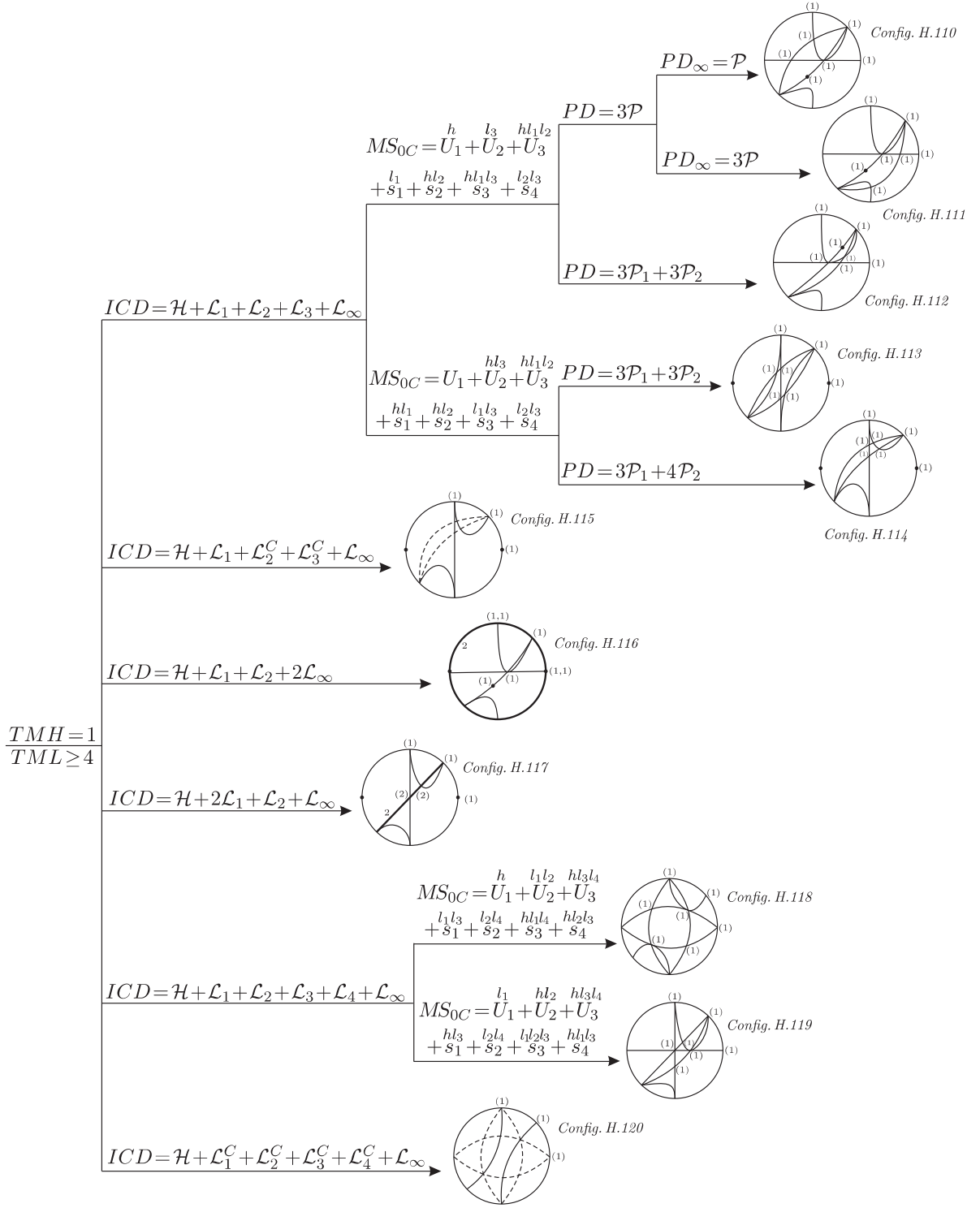

DIAGRAM 6: Diagram of configurations with one hyperbola and $TML \geq 4$

configurations of the following groups. The result is seen in the DIAGRAMS 3 to 9.

We finally obtain that the 162 geometric configurations displayed in DIAGRAMS 3 to 9 are distinct, which yields the geometric classification of the class **QSH** according to the configurations of invariant

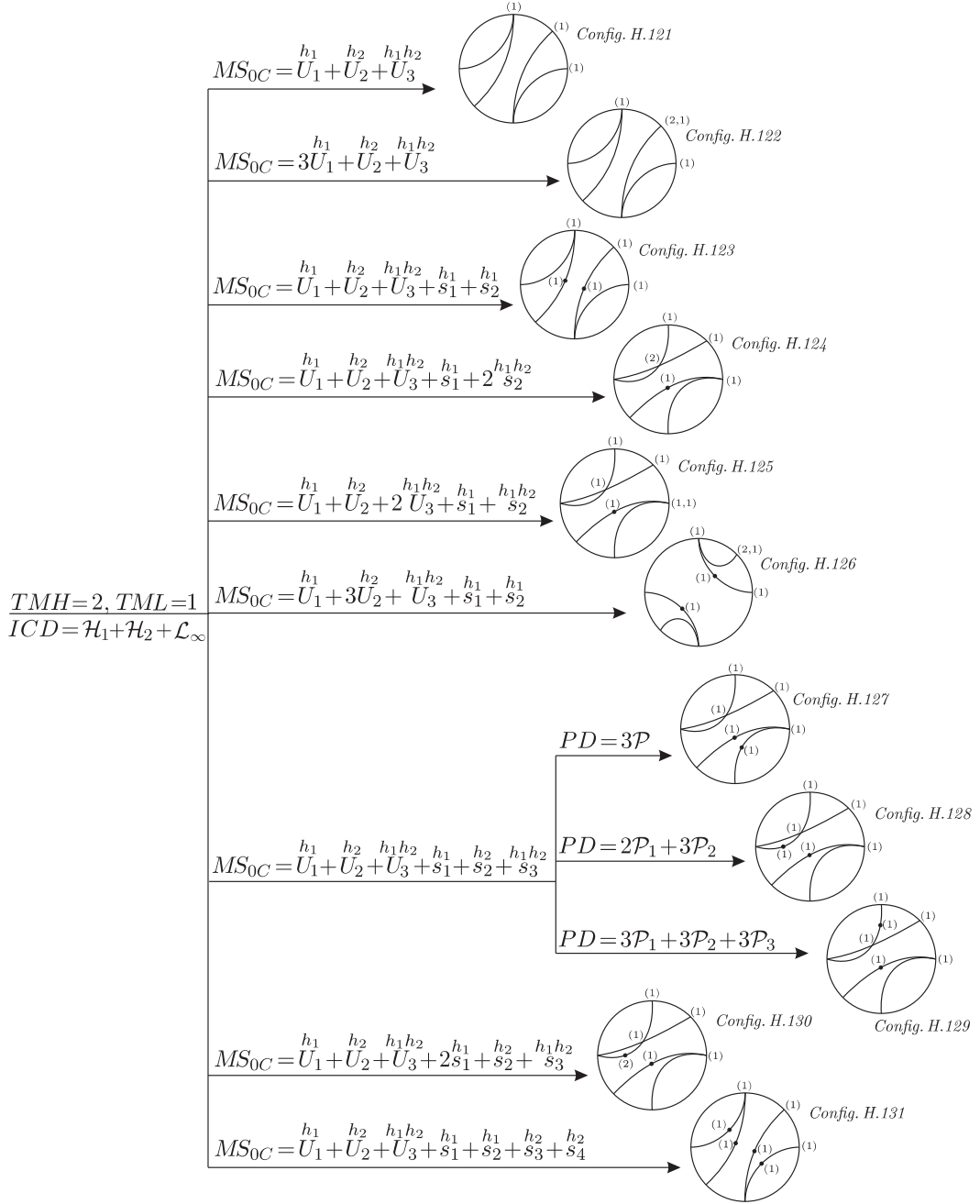

DIAGRAM 7: Diagram of configurations with two hyperbolas and $TM_L = 1$

hyperbolas and lines. This proves statement (A) of this theorem.

Proof of part (B). We assume $\eta > 0$. In this case according to [24, Lemma 44] there exist an affine transformation and time rescaling which brings systems (3) to the systems

$$\frac{dx}{dt} = a + cx + dy + gx^2 + (h-1)xy, \quad \frac{dy}{dt} = b + ex + fy + (g-1)xy + hy^2, \quad (9)$$

with $\eta = 1$ and $\theta = -(g-1)(h-1)(g+h)/2$.

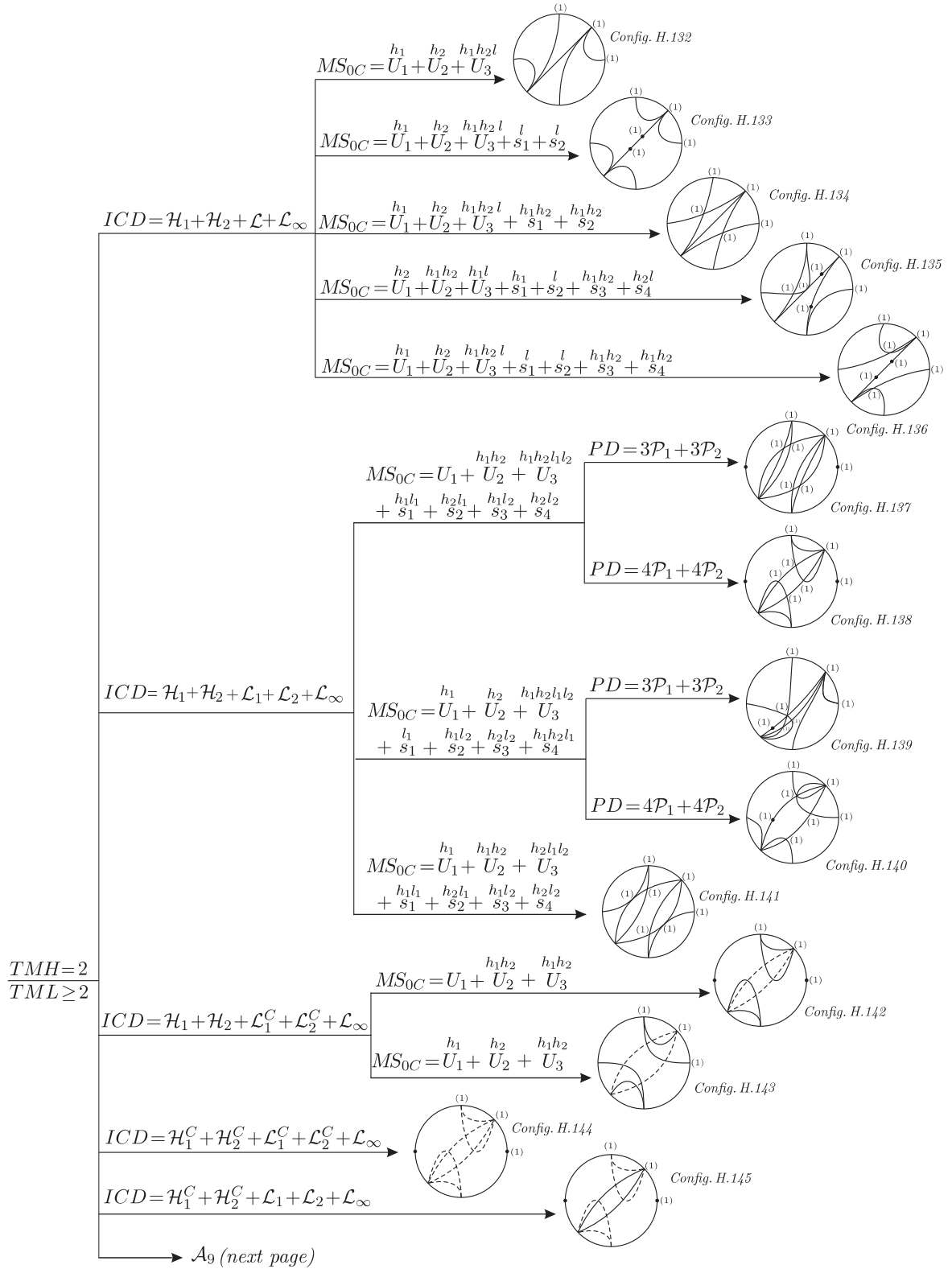

DIAGRAM 8: Diagram of configurations with two hyperbolas and $TML \geq 2$

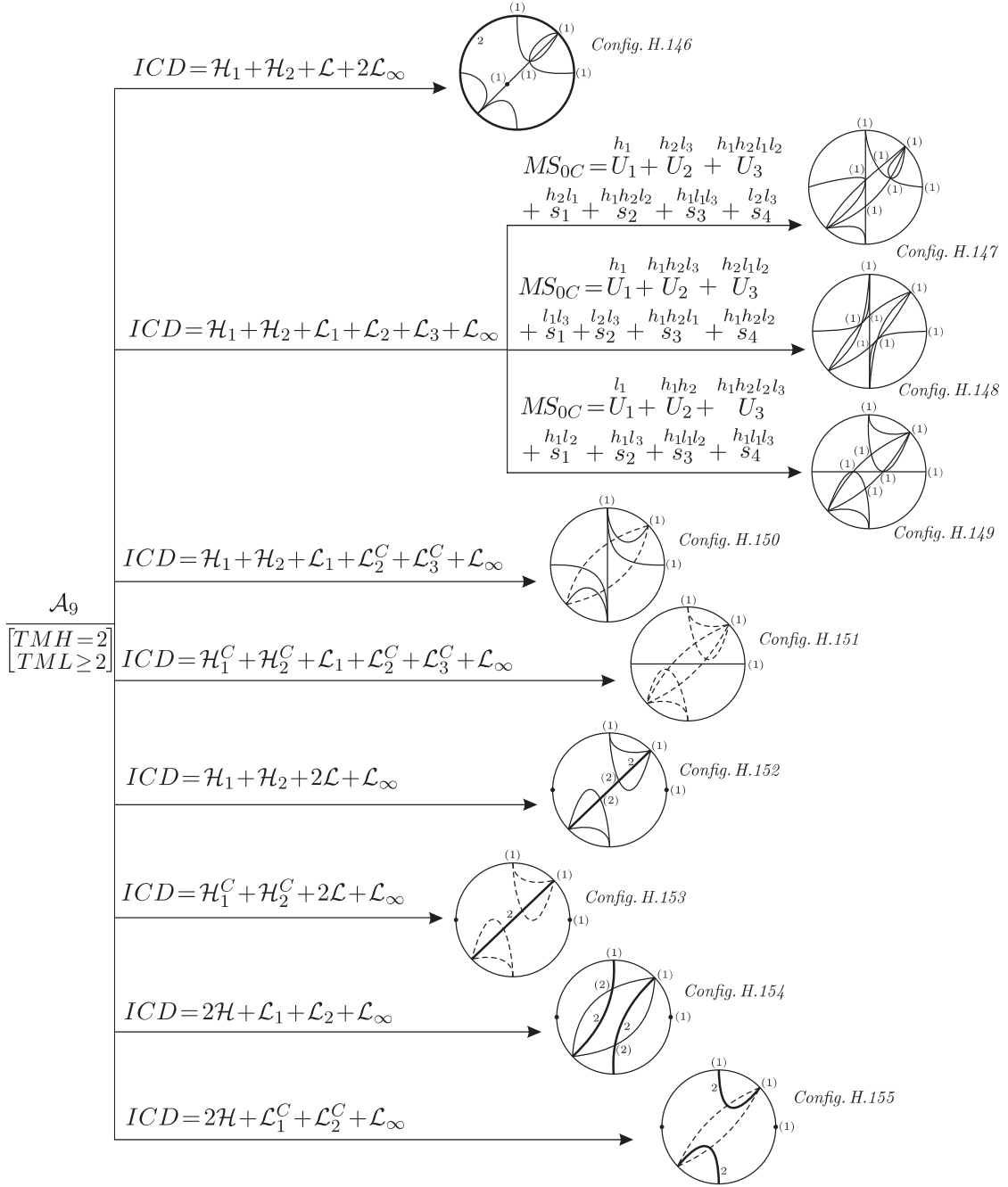

DIAGRAM 8: (*Cont.*) Diagram of configurations with two hyperbolas and $TML \geq 2$

3.1 The subcase $\theta \neq 0$

Following Theorem 3 we assume that for a quadratic system (9) the conditions $\theta \neq 0$ and $\gamma_1 = 0$ are fulfilled. Then, as it was proved in [15], due to an affine transformation and time rescaling, this system could be brought to the canonical form

$$\frac{dx}{dt} = a + cx + gx^2 + (h-1)xy, \quad \frac{dy}{dt} = b - cy + (g-1)xy + hy^2, \quad (10)$$

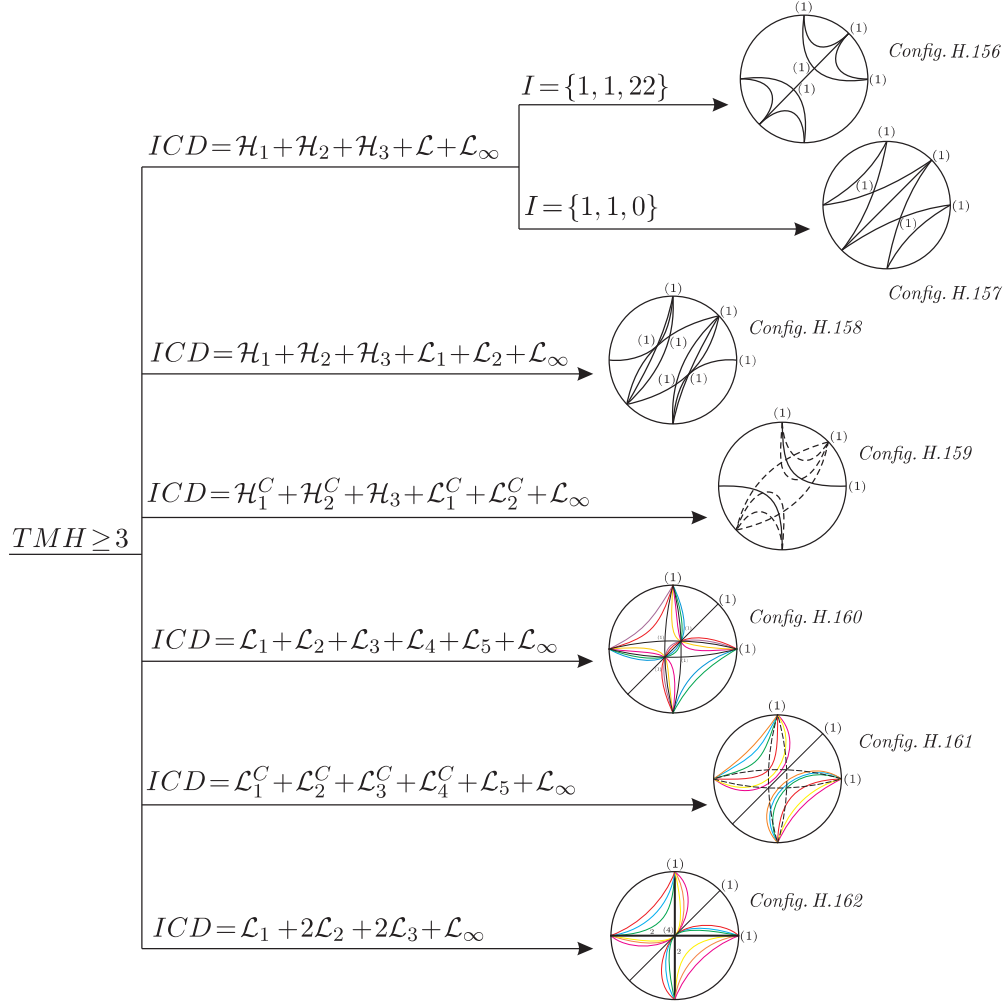

DIAGRAM 9: Diagram of configurations with three or more hyperbolas ($TMH \geq 3$)

for which we calculate

$$\begin{aligned}
\gamma_2 &= -1575c^2(g-1)^2(h-1)^2(g+h)(3g-1)(3h-1)(3g+3h-4)\mathcal{B}_1, \\
\beta_1 &= -c^2(g-1)(h-1)(3g-1)(3h-1)/4, \\
\beta_2 &= -c(g-h)(3g+3h-4)/2, \quad \theta = -(g-1)(h-1)(g+h)/2,
\end{aligned} \tag{11}$$

where $\mathcal{B}_1 = b(2h-1) - a(2g-1)$.

3.1.1 The possibility $\beta_1 \neq 0$

In this case the condition $\gamma_2 = 0$ is equivalent to $(3g+3h-4)\mathcal{B}_1 = 0$.

3.1.1.1 *The case $\beta_2 \neq 0$.* Then $3g+3h-4 \neq 0$ and we obtain $\mathcal{B}_1 = 0$. Since $c \neq 0$ due to the rescaling $(x, y, t) \mapsto (cx, cy, t/c)$ we may assume $c = 1$. Moreover as $(2g-1)^2 + (2h-1)^2 \neq 0$ due to $\beta_2 \neq 0$ (i.e. $g-h \neq 0$), the condition $\mathcal{B}_1 = 0$ could be written as $a = a_1(2h-1)$ and $b = a_1(2g-1)$.

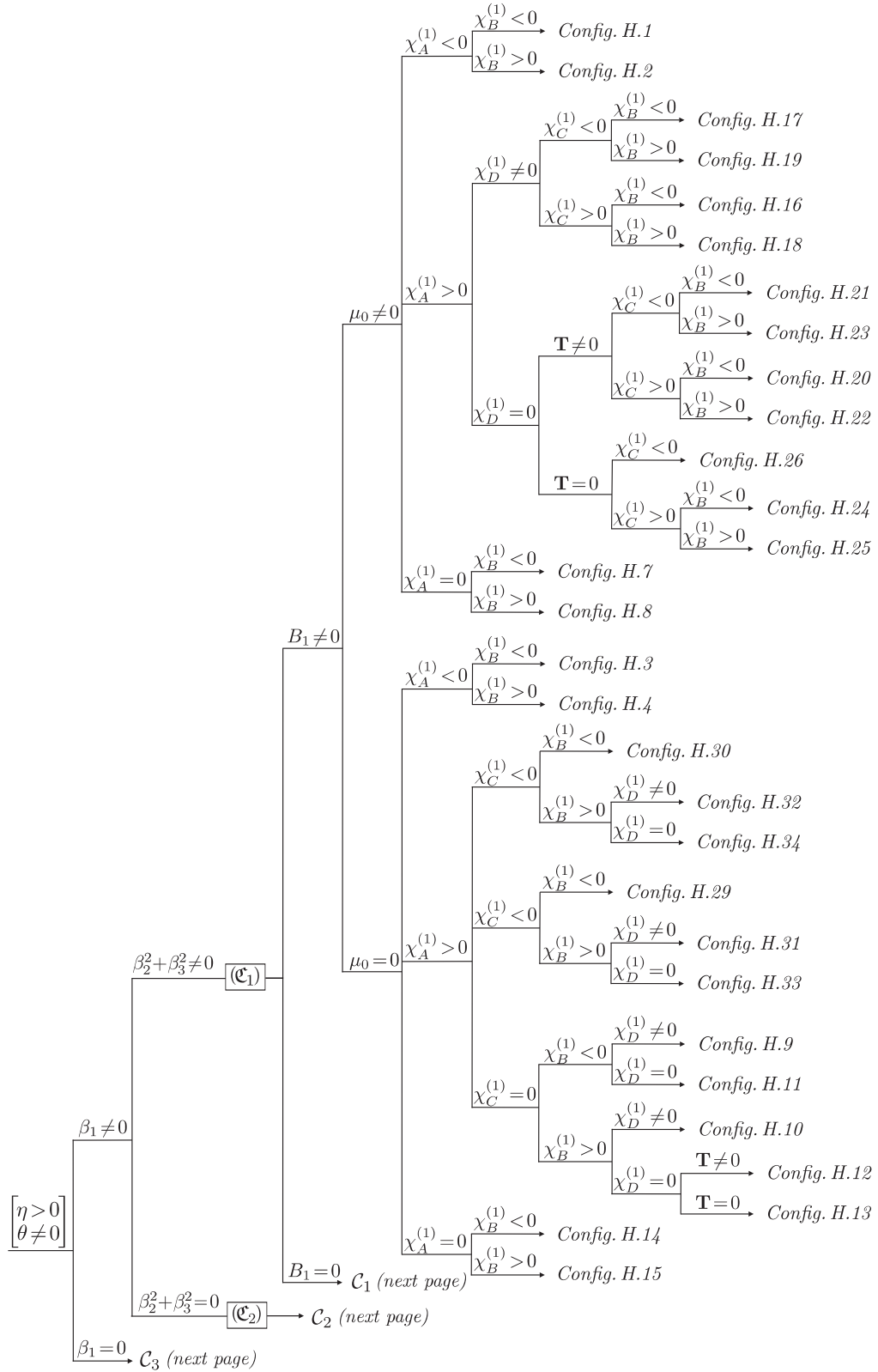

DIAGRAM 10: Bifurcation diagram in \mathbb{R}^{12} of the configurations: Case $\eta > 0$, $\theta \neq 0$

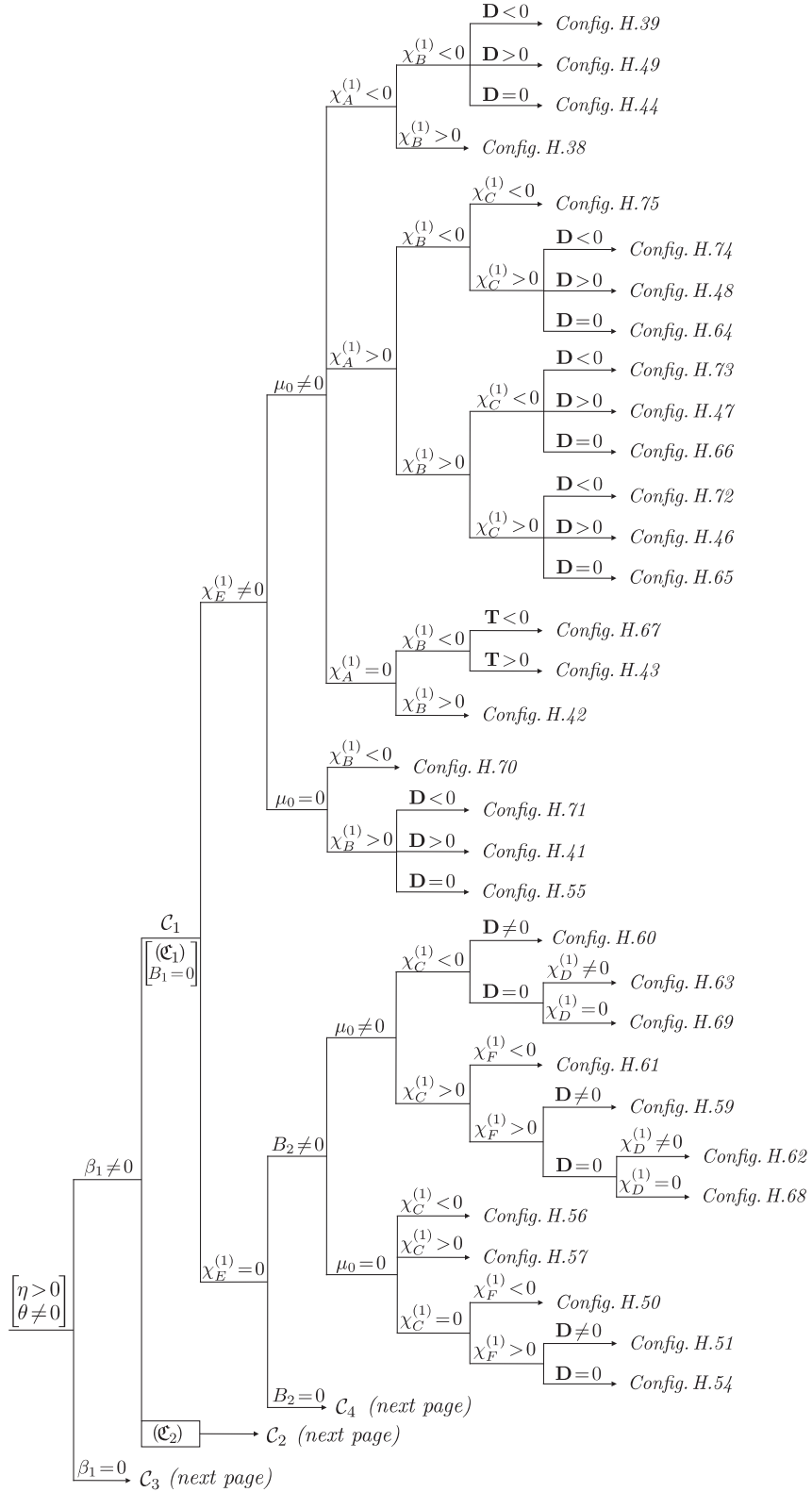

DIAGRAM 10: (Cont.) Bifurcation diagram in \mathbb{R}^{12} of the configurations: Case $\eta > 0$, $\theta \neq 0$

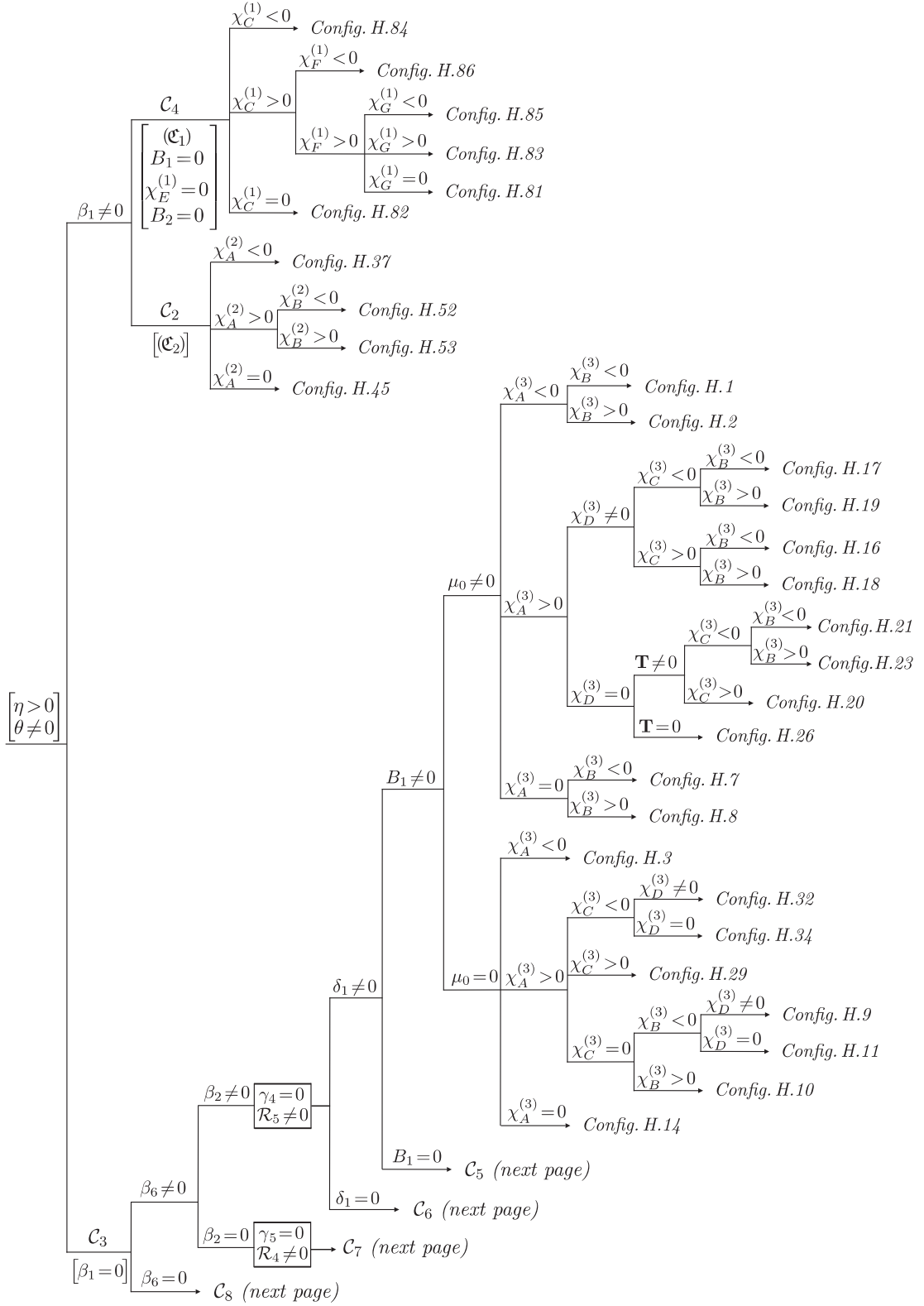

DIAGRAM 10: (Cont.) Bifurcation diagram in \mathbb{R}^{12} of the configurations: Case $\eta > 0$, $\theta \neq 0$

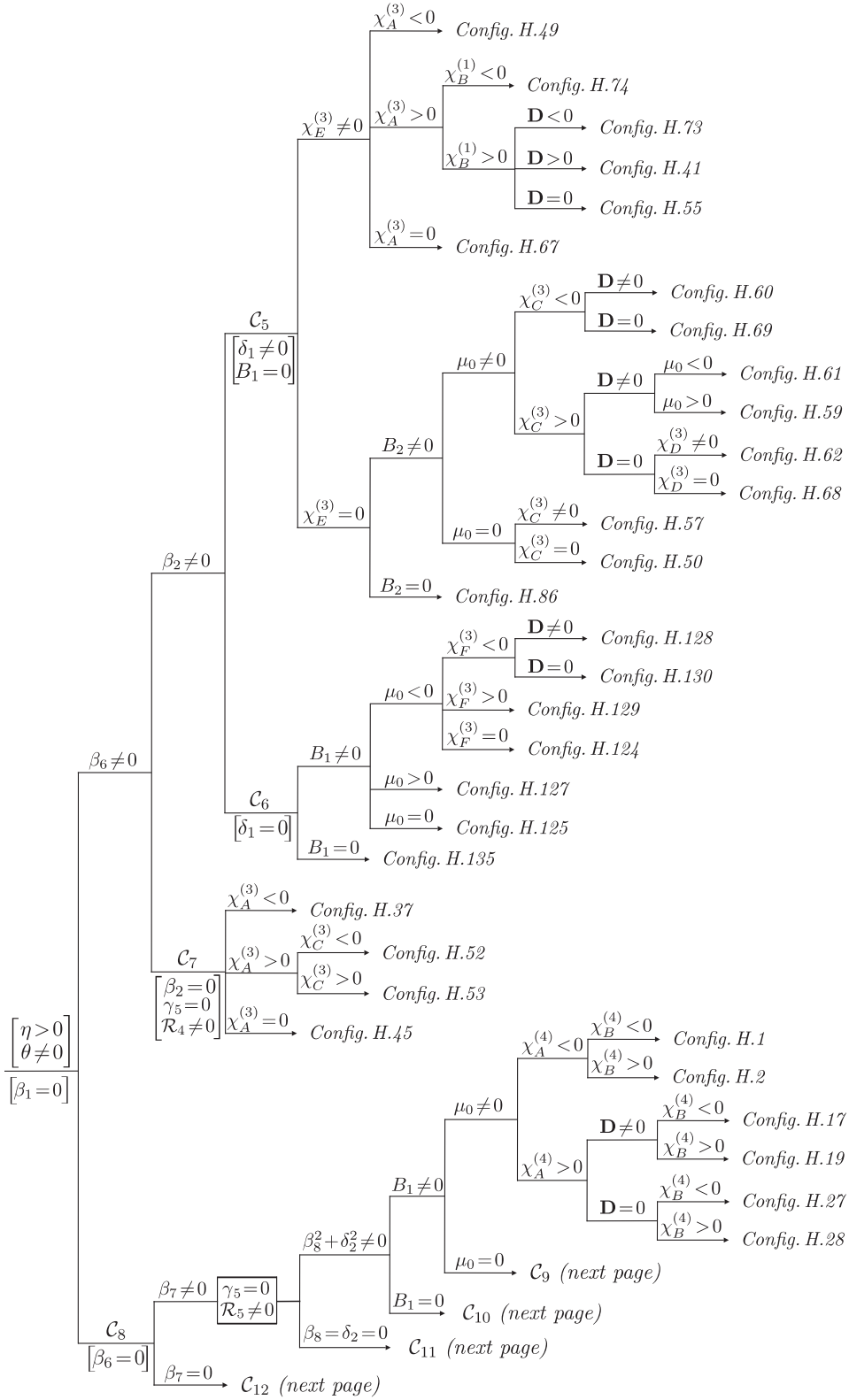

DIAGRAM 10: (Cont.) Bifurcation diagram in \mathbb{R}^{12} of the configurations: Case $\eta > 0$, $\theta \neq 0$

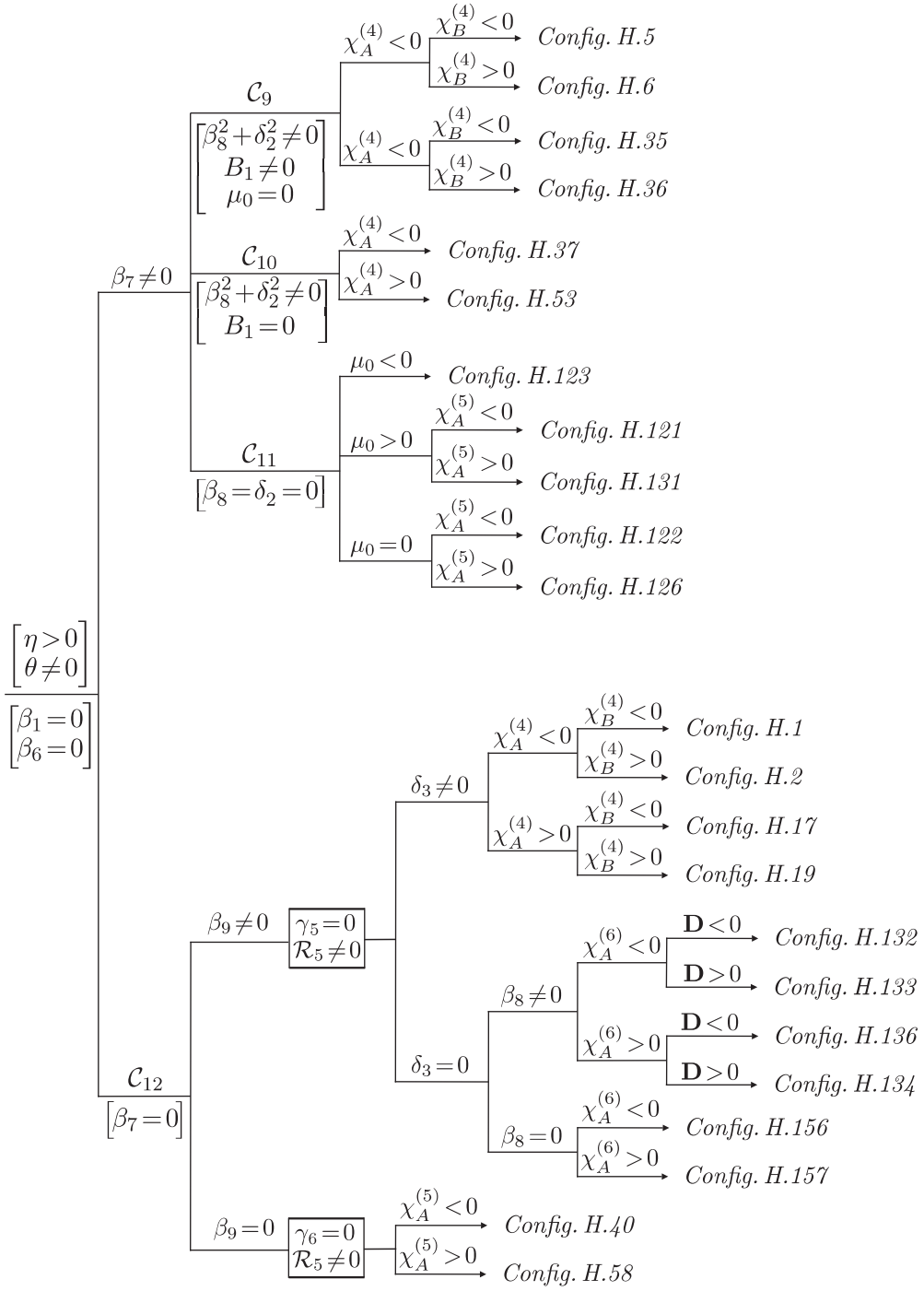

DIAGRAM 10: (Cont.) Bifurcation diagram in \mathbb{R}^{12} of the configurations: Case $\eta > 0$, $\theta \neq 0$

So setting the old parameter a instead of a_1 , we arrive at the 3-parameter family of systems

$$\frac{dx}{dt} = a(2h - 1) + x + gx^2 + (h - 1)xy, \quad \frac{dy}{dt} = a(2g - 1) - y + (g - 1)xy + hy^2 \quad (12)$$

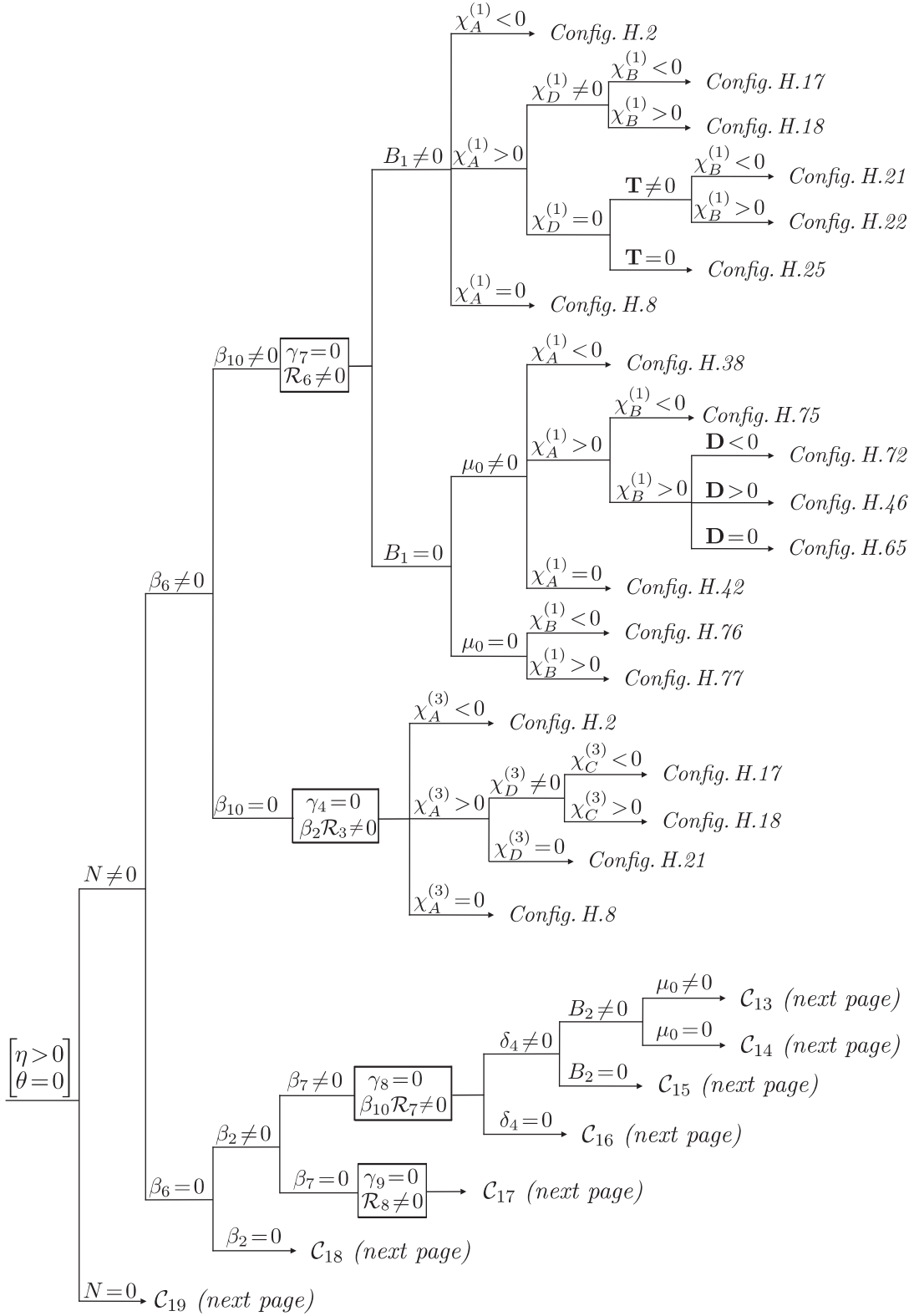

DIAGRAM 11: Bifurcation diagram in \mathbb{R}^{12} of the configurations: Case $\eta > 0$, $\theta = 0$

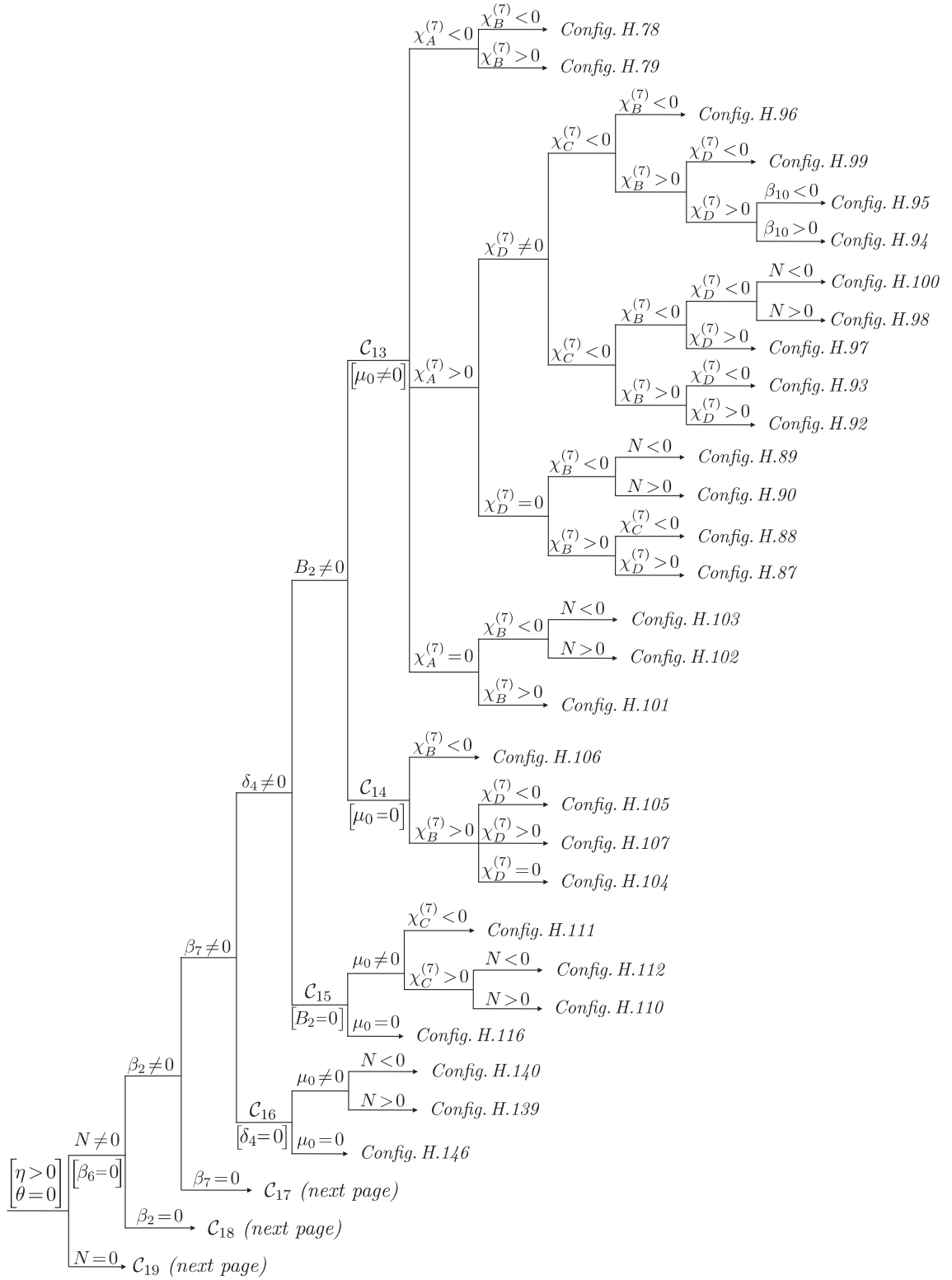

DIAGRAM 11: (Cont.) Bifurcation diagram in \mathbb{R}^{12} of the configurations: Case $\eta > 0$, $\theta = 0$

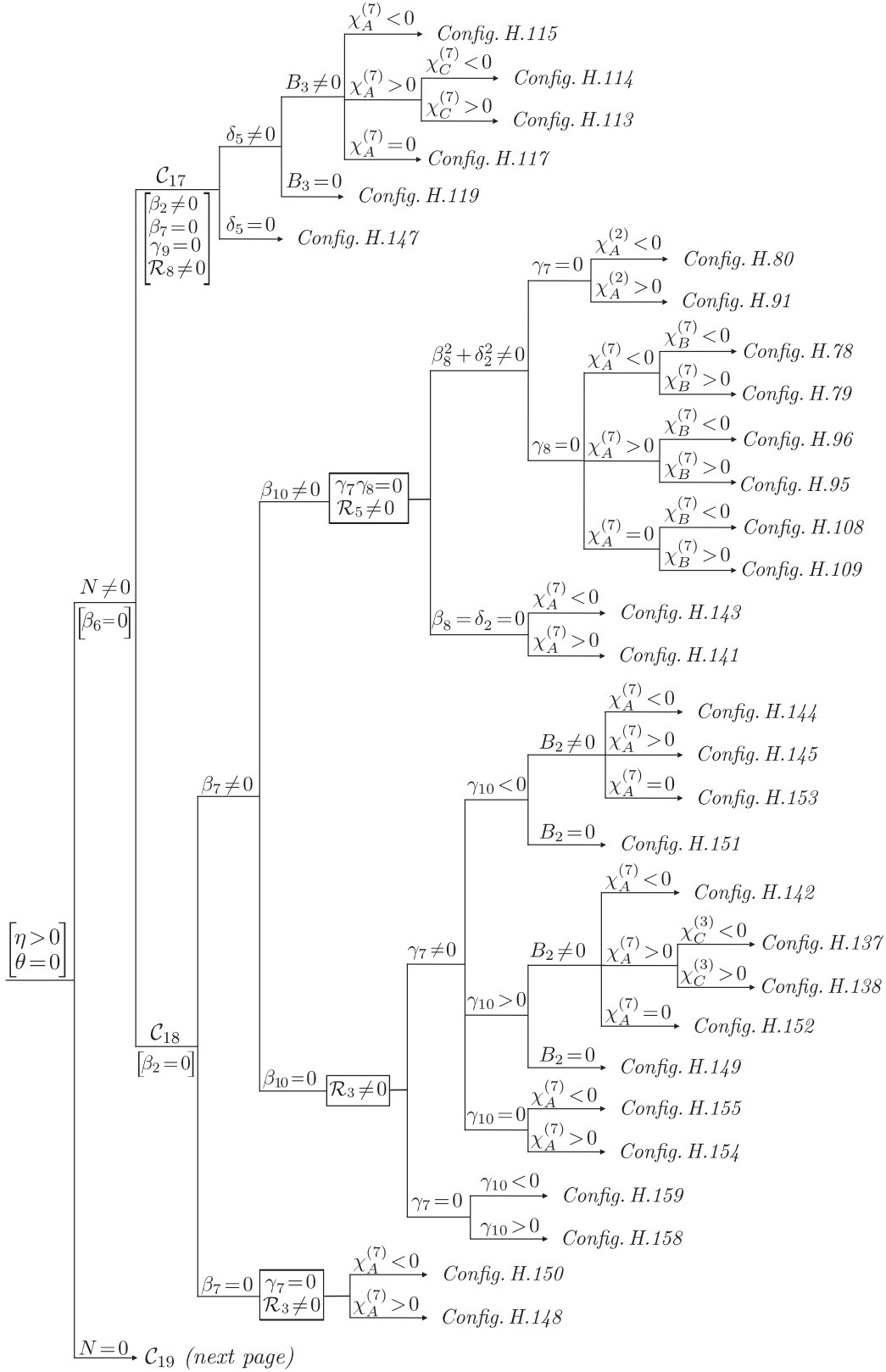

DIAGRAM 11: (Cont.) Bifurcation diagram in \mathbb{R}^{12} of the configurations: Case $\eta > 0, \theta = 0$

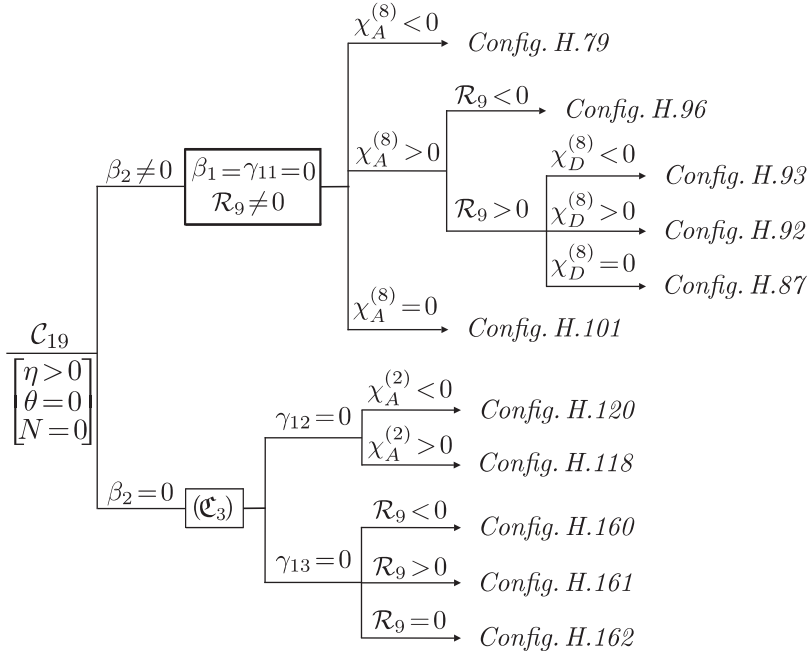

DIAGRAM 11: (Cont.) Bifurcation diagram in \mathbb{R}^{12} of the configurations: Case $\eta > 0$, $\theta = 0$

with the condition

$$a(g-1)(h-1)(g+h)(g-h)(3g-1)(3h-1)(3g+3h-4) \neq 0. \quad (13)$$

These systems possess the invariant hyperbola

$$\Phi(x, y) = a + xy = 0. \quad (14)$$

Remark 7. We point out that for systems (12) the parameters g and h have the same significance, because we could replace g by h via the change $(x, y, t, a, g, h) \mapsto (-y, -x, -t, a, h, g)$, which keeps these systems.

For systems (12) we calculate

$$B_1 = 2a^2(g-1)^2(h-1)^2(g-h)(2g-1)(2h-1)[a(g+h)^2 - 1]. \quad (15)$$

3.1.1.1.1 *The subcase $B_1 \neq 0$.* In this case by Lemma 2 we have no invariant lines. For systems (12) we calculate $\mu_0 = gh(g+h-1)$ and we consider two possibilities: $\mu_0 \neq 0$ and $\mu_0 = 0$.

a) The possibility $\mu_0 \neq 0$. Then by Lemma 1 the systems have finite singularities of total multiplicity 4. We detect that two of these singularities are located on the hyperbola, more exactly such singularities are $M_{1,2}(x_{1,2}, y_{1,2})$ with

$$x_{1,2} = \frac{-1 \pm \sqrt{Z_1}}{2g}, \quad y_{1,2} = \frac{1 \pm \sqrt{Z_1}}{2h}, \quad Z_1 = 1 - 4agh.$$

On the other hand for systems (12) we calculate the invariant polynomial

$$\begin{aligned}\chi_A^{(1)} &= (g-1)^2(h-1)^2(g-h)^2(3g-1)^2(3h-1)^2 Z_1, \\ \chi_B^{(1)} &= -105a(g-1)^2(h-1)^2(g-h)^2(3g-1)^2(3h-1)^2/8\end{aligned}$$

and by (123) we conclude that $\text{sign}(\chi_A^{(1)}) = \text{sign}(Z_1)$ (if $Z_1 \neq 0$) and $\text{sign}(\chi_B^{(1)}) = -\text{sign}(a)$. So we consider three cases: $\chi_A^{(1)} < 0$, $\chi_A^{(1)} > 0$ and $\chi_A^{(1)} = 0$.

a₁) *The case* $\chi_A^{(1)} < 0$. So we have no real singularities located on the invariant hyperbola and we arrive at the configurations of invariant curves given by *Config. H.1* if $\chi_B^{(1)} < 0$ and *Config. H.2* if $\chi_B^{(1)} > 0$.

a₂) *The case* $\chi_A^{(1)} > 0$. In this case we have two real singularities located on the hyperbola. We have the next result.

Lemma 7. *Assume that the singularities $M_{1,2}(x_{1,2}, y_{1,2})$ (located on the hyperbola) are finite. Then these singularities are located on different branches of the hyperbola if $\chi_C^{(1)} < 0$ and they are located on the same branch if $\chi_C^{(1)} > 0$.*

Proof: Since the asymptotes of the hyperbola (122) are the lines $x = 0$ and $y = 0$ it is clear that the singularities $M_{1,2}$ are located on different branches of the hyperbola if and only if $x_1 x_2 < 0$. We calculate

$$\begin{aligned}x_1 x_2 &= \left[\frac{-1 + \sqrt{Z_1}}{2g} \right] \left[\frac{-1 - \sqrt{Z_1}}{2g} \right] = \frac{ah}{g}, \\ \chi_C^{(1)} &= 35agh(g-1)^4(h-1)^4(g-h)^2(g+h)^2(3g-1)^2(3h-1)^2/32\end{aligned}\tag{16}$$

and due to the condition (123) we obtain that $\text{sign}(x_1 x_2) = \text{sign}(\chi_C^{(1)})$. This completes the proof of the lemma. ■

Other two singular points of systems (12) are $M_{3,4}(x_{3,4}, y_{3,4})$ (generically located outside the hyperbola) with

$$x_{3,4} = \frac{(1-2h)[1 \pm \sqrt{Z_2}]}{2(g+h-1)}, \quad y_{3,4} = \frac{(2g-1)[1 \pm \sqrt{Z_2}]}{2(g+h-1)}, \quad Z_2 = 1 + 4a(1-g-h).\tag{17}$$

We need to determine the conditions when the singular points located outside the hyperbola coincide with its points (singular for the systems or not). In this order considering (122) we calculate

$$\Phi(x, y)|_{\{x=x_{3,4}, y=y_{3,4}\}} = \frac{\tilde{A} - (2g-1)(2h-1)[1 \pm \sqrt{Z_2}]}{2(g+h-1)^2} \equiv \Omega_{3,4}(a, g, h),$$

where $\tilde{A} = 2a(g+h-1)(4gh-g-h)$. It is clear that at least one of the singular points $M_3(x_3, y_3)$ or $M_4(x_4, y_4)$ belongs to the hyperbola (122) if and only if

$$\Omega_3 \Omega_4 = -\frac{a Z_3}{(g+h-1)^2} = 0, \quad Z_3 = (2g-1)(2h-1) - a(4gh-g-h)^2.$$

On the other hand for systems (12) we have

$$\chi_D^{(1)} = 105(g-h)(3g-1)(3h-1) Z_3/4$$

and clearly due to (123) the condition $\chi_D^{(1)} = 0$ is equivalent to $Z_3 = 0$. We examine two subcases: $\chi_D^{(1)} \neq 0$ and $\chi_D^{(1)} = 0$.

α) *The subcase $\chi_D^{(1)} \neq 0$.* Then $Z_3 \neq 0$ and on the hyperbola there are two simple real singularities (namely $M_{1,2}(x_{1,2}, y_{1,2})$). By Lemma 8 their position is defined by the invariant polynomial $\chi_C^{(1)}$ and we arrive at the following conditions and configurations:

- $\chi_C^{(1)} < 0$ and $\chi_B^{(1)} < 0 \Rightarrow \text{Config. H.17};$
- $\chi_C^{(1)} < 0$ and $\chi_B^{(1)} > 0 \Rightarrow \text{Config. H.19};$
- $\chi_C^{(1)} > 0$ and $\chi_B^{(1)} < 0 \Rightarrow \text{Config. H.16};$
- $\chi_C^{(1)} > 0$ and $\chi_B^{(1)} > 0 \Rightarrow \text{Config. H.18}.$

β) *The subcase $\chi_D^{(1)} = 0$.* In this case the conditions $Z_3 = 0$, $B_1 \neq 0$ (see (124)) and (123) implies $4gh - g - h \neq 0$ and we obtain $a = (2g - 1)(2h - 1)/(4gh - g - h)^2$. Then considering Proposition 1 we calculate

$$\mathbf{D} = 0, \quad \mathbf{T} = -3[g(g - 1)(2h - 1)x + h(h - 1)(2g - 1)y]^2 \mathbf{P},$$

$$\mathbf{P} = \frac{(g - h)^2}{(4gh - g - h)^4} (2 - 3g - 3h + 4gh)^2 (gx - hy)^2 [(2g - 1)x + (2h - 1)y]^2.$$

β_1) *The possibility $\mathbf{T} \neq 0$.* Then $\mathbf{T} < 0$ and according to Proposition 1 systems (12) possess one double and two simple real finite singularities. More exactly, we detect that one of the singular points $M_3(x_3, y_3)$ or $M_4(x_4, y_4)$ collapses with a singular point located on the hyperbola, whereas another one remains outside the hyperbola. Taking into consideration Lemma 8 we obtain the following conditions and configurations:

- $\chi_C^{(1)} < 0$ and $\chi_B^{(1)} < 0 \Rightarrow \text{Config. H.21};$
- $\chi_C^{(1)} < 0$ and $\chi_B^{(1)} > 0 \Rightarrow \text{Config. H.23};$
- $\chi_C^{(1)} > 0$ and $\chi_B^{(1)} < 0 \Rightarrow \text{Config. H.20};$
- $\chi_C^{(1)} > 0$ and $\chi_B^{(1)} > 0 \Rightarrow \text{Config. H.22}.$

β_2) *The possibility $\mathbf{T} = 0$.* In this case due to the conditions (123) and $\mu_0 \neq 0$ the equality $\mathbf{T} = 0$ holds if and only if $\mathbf{P} = 0$ which is equivalent to $2 - 3g - 3h + 4gh = 0$ (or equivalently $2 - 3g + h(4g - 3) = 0$). Since $g - h \neq 0$ (see (123)), the condition $(4g - 3)^2 + (4h - 3)^2 \neq 0$ holds, then by Remark 7 we may assume $(4g - 3) \neq 0$, i.e. $h = (3g - 2)/(4g - 3)$ and we obtain

$$\mathbf{D} = \mathbf{T} = \mathbf{P} = 0, \quad \mathbf{R} = \frac{3}{(4g - 3)^4} (g - 1)^2 (2g - 1)^2 [g(4g - 3)x + (2 - 3g)y]^2.$$

Since $\mathbf{R} \neq 0$, by Proposition 1 we obtain one triple and one simple singularities. More precisely the singular points M_3 and M_4 collapse with one of the singular points M_1 or M_2 and the last point becomes a triple one. In this case, we calculate

$$\chi_B^{(1)} = -\frac{105(g - 1)^6 (3g - 1)^2 (5g - 3)^2}{8(4g - 3)^5}, \quad \chi_C^{(1)} = \frac{35g(3g - 2)(g - 1)^{10} (3g - 1)^2 (5g - 3)^2 (2g^2 - 1)^2}{8(4g - 3)^{10}}.$$

We remark that the condition $\chi_C^{(1)} < 0$ implies $\chi_B^{(1)} > 0$. Indeed, if $\chi_C^{(1)} < 0$ then $g(3g - 2) < 0$ (i.e. $0 < g < 2/3$) and for these values of g we have $4g - 3 < 0$, which is equivalent to $\chi_B^{(1)} > 0$. Taking into consideration Lemma 8 we obtain the following conditions and configurations:

- $\chi_C^{(1)} < 0 \Rightarrow \text{Config. H.26}$;
- $\chi_C^{(1)} > 0$ and $\chi_B^{(1)} < 0 \Rightarrow \text{Config. H.24}$;
- $\chi_C^{(1)} > 0$ and $\chi_B^{(1)} > 0 \Rightarrow \text{Config. H.25}$.

a₃) The case $\chi_A^{(1)} = 0$. Due to the condition (123), the condition $\chi_A^{(1)} = 0$ implies $Z_1 = 0$ and it yields $a = 1/(4gh)$. In this case the points $M_{1,2}$ collapse and we have a double point on the hyperbola. So we calculate

$$\begin{aligned}\chi_B^{(1)} &= -\frac{105}{32gh}(g-1)^2(h-1)^2(g-h)^2(3g-1)^2(3h-1)^2, \\ \chi_C^{(1)} &= 35(g-1)^4(h-1)^4(g-h)^2(g+h)^2(3g-1)^2(3h-1)^2/128 > 0, \\ \chi_D^{(1)} &= -\frac{105}{16gh}(g-h)^3(3g-1)(3h-1) \neq 0.\end{aligned}$$

Since $\chi_C^{(1)} \neq 0$, no other point could coalesce with the double point on the hyperbola and we arrive at the configurations given by *Config. H.7* if $\chi_B^{(1)} < 0$ and *Config. H.8* if $\chi_B^{(1)} > 0$.

b) The possibility $\mu_0 = 0$. Then by Lemma 1 at least one finite singular point has gone to infinity and collapsed with one of the infinite singular points $[1, 0, 0]$, $[0, 1, 0]$ or $[1, 1, 0]$. By the same lemma, a second point could go to infinity if and only if $\mu_1(x, y) = 0$. However, for systems (123) we have the following remark.

Remark 8. *If for a system (12) the condition $\mu_0 = 0$ holds then $\mu_1 \neq 0$. Moreover by (4) the condition $\mathbf{R} = 3\mu_1^2 \neq 0$ is fulfilled.*

Indeed for systems (12) we calculate

$$\mu_0 = gh(g+h-1) = 0, \quad \mu_1 = g(1-g-2gh)x + h(1-h-2gh)y. \quad (18)$$

We observe that in the case $g = 0$ (respectively $h = 0$; $g = 1 - h$) we get $\mu_1 = h(1-h)y \neq 0$ (respectively $\mu_1 = g(1-g)y \neq 0$; $\mu_1 = h(h-1)(2h-1)(x-y) \neq 0$) due to the condition (123).

We consider the cases: $\chi_A^{(1)} < 0$, $\chi_A^{(1)} > 0$ and $\chi_A^{(1)} = 0$.

b₁) The case $\chi_A^{(1)} < 0$. The points on the hyperbola are complex and, moreover, $1 - 4agh < 0$ implies $agh > 0$ and hence $\chi_C^{(1)} > 0$. Then we arrive at the configurations given by *Config. H.3* if $\chi_B^{(1)} < 0$ and *Config. H.4* if $\chi_B^{(1)} > 0$.

b₂) The case $\chi_A^{(1)} > 0$. The points on the hyperbola are real and we observe that due to the condition (123) the equality $\chi_C^{(1)} = 0$ is equivalent to $gh = 0$. So we consider two subcases: $\chi_C^{(1)} \neq 0$ and $\chi_C^{(1)} = 0$.

α) The subcase $\chi_C^{(1)} \neq 0$. Then the condition $\mu_0 = 0$ gives $g + h - 1 = 0$, i.e. $g = 1 - h$ and one finite singularity has gone to infinity and collapsed with the point $[1, 1, 0]$. Clearly that this must

be a singular point located outside the hyperbola and hence on the finite part of the phase plane of systems (12) there are three singularities, two of which (M_1 and M_2) being located on the hyperbola.

Since the singular points on the hyperbola are real we have to decide when the third point will belong also to the hyperbola. For systems (12) with $g = 1 - h$ we calculate

$$\begin{aligned}\chi_B^{(1)} &= -105ah^2(h-1)^2(2h-1)^2(3h-1)^2(3h-2)^2/8, \\ \chi_D^{(1)} &= 105(2h-1)^3(2-3h)(3h-1)[1+a(2h-1)^2]/4.\end{aligned}$$

We observe that the condition $\chi_B^{(1)} < 0$ implies $\chi_D^{(1)} \neq 0$. Indeed, supposing $\chi_D^{(1)} = 0$ and considering condition (123), we obtain $a = -1/(2h-1)^2$ and hence

$$\chi_B^{(1)} = 105h^2(h-1)^2(3h-1)^2(3h-2)^2/8 > 0.$$

So in the case $\chi_C^{(1)} < 0$ we get the following conditions and configurations:

- $\chi_B^{(1)} < 0 \Rightarrow \text{Config. H.30};$
- $\chi_B^{(1)} > 0$ and $\chi_D^{(1)} \neq 0 \Rightarrow \text{Config. H.32};$
- $\chi_B^{(1)} > 0$ and $\chi_D^{(1)} = 0 \Rightarrow \text{Config. H.34};$

whereas for $\chi_C^{(1)} > 0$ we get

- $\chi_B^{(1)} < 0 \Rightarrow \text{Config. H.29};$
- $\chi_B^{(1)} > 0$ and $\chi_D^{(1)} \neq 0 \Rightarrow \text{Config. H.31};$
- $\chi_B^{(1)} > 0$ and $\chi_D^{(1)} = 0 \Rightarrow \text{Config. H.33}.$

β) *The subcase $\chi_C^{(1)} = 0$.* Then $gh = 0$ and $g^2 + h^2 \neq 0$ due to $g - h \neq 0$. By Remark 7 we may assume $g = 0$ and then one of the singularities located on the hyperbola (122) has gone to infinity and collapsed with the point $[1, 0, 0]$. The calculations yield

$$\chi_B^{(1)} = -105ah^2(h-1)^2(3h-1)^2/8, \quad \chi_D^{(1)} = 105h(3h-1)(1-2h-ah^2)/4. \quad (19)$$

β_1) *The possibility $\chi_B^{(1)} < 0$.* Then we have to analyze two cases: $\chi_D^{(1)} \neq 0$ and $\chi_D^{(1)} = 0$.

If $\chi_D^{(1)} \neq 0$, the finite singularities $M_{3,4}$ remain outside the hyperbola and we arrive at the configuration given by *Config. H.9*. In the case $\chi_D^{(1)} = 0$ (which yields $a = (1-2h)/h^2$), one of the singular points $M_{3,4}$ coalesces with the remaining singularity on the hyperbola. For this case we calculate

$$\mathbf{D} = 0, \quad \mathbf{P} = (3h-2)^2y^2(x+y-2hy)^2, \quad \mathbf{T} = -3h^2(h-1)^2y^2\mathbf{P}.$$

We observe that the condition $\chi_B^{(1)} > 0$ implies $\mathbf{T} \neq 0$. Indeed, the conditions $\chi_D^{(1)} = \mathbf{T} = 0$ imply $h = 2/3$ and $a = -3/4$, and hence $\chi_B^{(1)} > 0$.

Moreover, according to Remark 8, in the case $\mu_0 = 0$, the condition $\mathbf{R} \neq 0$ is satisfied for systems (12). Then, since $\mathbf{T} \neq 0$, we obtain $\mathbf{PR} \neq 0$, and by Proposition 1 we have a double singular point on the hyperbola and we arrive at *Config. H.11*.

β_2) *The possibility* $\chi_B^{(1)} > 0$. We again analyze the cases $\chi_D^{(1)} \neq 0$ and $\chi_D^{(1)} = 0$. In the case $\chi_D^{(1)} \neq 0$, the finite singularities $M_{3,4}$ remain outside the hyperbola and we arrive at the configuration given by *Config. H.10*. If $\chi_D^{(1)} = 0$, we obtain the configurations shown in *Config. H.12* if $\mathbf{T} \neq 0$ and *Config. H.13* if $\mathbf{T} = 0$.

b_3) *The case* $\chi_A^{(1)} = 0$. Due to the condition (123), the condition $\chi_A^{(1)} = 0$ implies $Z_1 = 0$ (then $gh \neq 0$) and hence $a = 1/(4gh)$. Therefore the condition $\mu_0 = 0$ yields $g = 1 - h$. In this case the singular points $M_{1,2}$ collapse and we have a double point on the hyperbola. For systems (12) with $g = 1 - h$ and $a = 1/[4h(1 - h)]$, we calculate

$$\begin{aligned}\chi_B^{(1)} &= 105h(h-1)(2h-1)^2(3h-1)^2(3h-2)^2/32, \\ \chi_C^{(1)} &= \frac{35}{128}h^4(h-1)^4(2h-1)^2(3h-1)^2(3h-2)^2, \\ \chi_D^{(1)} &= \frac{105}{16h(h-1)}(2h-1)^3(3h-1)(3h-2), \\ \mathbf{D} &= 0, \quad \mathbf{T} = -3h^2(h-1)^2(2h-1)^2(x-y)^4(x+y)^2 \neq 0.\end{aligned}$$

Since $\chi_D^{(1)} \neq 0$ (due to condition (123)), the singular point located outside the hyperbola could not collapse with this double point and we arrive at the configurations given by *Config. H.14* if $\chi_B^{(1)} < 0$ and *Config. H.15* if $\chi_B^{(1)} > 0$.

3.1.1.1.2 *The subcase* $B_1 = 0$. According to Lemma 2 the condition $B_1 = 0$ is necessary in order to exist an invariant line of systems (12). Considering the condition (123) we obtain that $B_1 = 0$ (see (124)) is equivalent to

$$(2g-1)(2h-1)[a(g+h)^2-1] = 0.$$

On the other hand, for these systems we calculate

$$\chi_E^{(1)} = -105(g-1)(h-1)(g-h)(3g-1)(3h-1)Z_4, \quad Z_4 = [a(g+h)^2-1],$$

and by (123) the condition $Z_4 = 0$ is equivalent to $\chi_E^{(1)} = 0$.

a) *The possibility* $\chi_E^{(1)} \neq 0$. In this case we get $g = 1/2$ and this leads to the systems

$$\frac{dx}{dt} = a(2h-1) + x + x^2/2 + (h-1)xy, \quad \frac{dy}{dt} = -y(2+x-2hy)/2, \quad (20)$$

for which the following condition holds (see (123)):

$$a(h-1)(2h-1)(2h+1)(3h-1)(6h-5) \neq 0. \quad (21)$$

We observe that besides the hyperbola (122) these systems possess the invariant line $y = 0$, which is one of the asymptotes of this hyperbola. For the above systems we calculate

$$\begin{aligned}\mu_0 &= h(2h-1)/4, \quad \chi_E^{(1)} = -\frac{105}{8}(h-1)(2h-1)(3h-1)Z_4|_{\{g=1/2\}}, \\ B_1 &= 0, \quad B_2 = -648a(h-1)^2(2h-1)^2y^4Z_4|_{\{g=1/2\}}.\end{aligned}$$

Therefore we conclude that due to the conditions $\chi_E^{(1)} \neq 0$ and (21) we obtain $B_2 \neq 0$ and, by Lemma 2, we could not have an invariant line in a direction which is different from $y = 0$. Moreover, due to the condition $\theta \neq 0$ and according to Lemma 4, in the direction $y = 0$ we could not have either a couple of parallel invariant lines or a double invariant line.

α_1) *The case $\mu_0 \neq 0$.* Then $h(2h - 1) \neq 0$ and considering the coordinates of the singularities $M_i(x_i, y_i)$ ($i=1,2,3,4$) mentioned earlier (see page 46) for $g = 1/2$ we have

$$\begin{aligned} x_{1,2} &= -1 \pm \sqrt{1 - 2ah}, & y_{1,2} &= -1 \mp \sqrt{1 - 2ah}, \\ x_{3,4} &= -1 \pm \sqrt{1 + 2a(1 - 2h)}, & y_{3,4} &= 0. \end{aligned}$$

We recall that the singular points $M_{1,2}(x_{1,2}, y_{1,2})$ are located on the hyperbola. We also observe that the singularities $M_{3,4}(x_{3,4}, y_{3,4})$ are located on the invariant line $y = 0$.

On the other hand, for systems (20) we calculate

$$\begin{aligned} \chi_A^{(1)} &= 2^{-12}(h - 1)^2(2h - 1)^2(3h - 1)^2(1 - 2ah), & \chi_B^{(1)} &= -105a(h - 1)^2(2h - 1)^2(3h - 1)^2/512, \\ \chi_C^{(1)} &= 2^{-16}35ah(h - 1)^4(2h - 1)^2(2h + 1)^2(3h - 1)^2, & \mathbf{D} &= 3a^2(2h - 1)^4[2a(2h - 1) - 1](1 - 2ah), \end{aligned}$$

and it is clear that, due to the factors $1 - 2ah$ and $1 + 2a(1 - 2h)$, the invariant polynomials $\chi_A^{(1)}$ and \mathbf{D} govern the types of the above singular points (i.e. are they real or complex or coinciding), whereas the invariant polynomials $\chi_B^{(1)}$ and $\chi_C^{(1)}$ are respectively responsible for the position of the hyperbola on the plane and for the location of the real singularities on the hyperbola (i.e. on the same branch or on the different ones).

α) *The subcase $\chi_A^{(1)} < 0$.* Then the singularities $M_{1,2}$ (located on the hyperbola) are complex, whereas the types of singularities $M_{3,4}$ (located on the invariant line $y = 0$) are governed by \mathbf{D} . We observe that clearly the condition $\chi_A^{(1)} < 0$ implies $\chi_C^{(1)} > 0$.

Furthermore, we see that $\chi_B^{(1)} > 0$ implies $\mathbf{D} < 0$. Indeed, the condition $\chi_B^{(1)} > 0$ yields $a < 0$ and, since $1 - 2ah < 0$ (i.e. $4ah > 2$), we have $2a(2h - 1) - 1 = 4ah - 2a - 1 > 0$; then $\mathbf{D} < 0$. So we arrive at the following conditions and configurations:

- $\chi_B^{(1)} < 0$ and $\mathbf{D} < 0 \Rightarrow$ *Config. H.39*;
- $\chi_B^{(1)} < 0$ and $\mathbf{D} > 0 \Rightarrow$ *Config. H.49*;
- $\chi_B^{(1)} < 0$ and $\mathbf{D} = 0 \Rightarrow$ *Config. H.44*;
- $\chi_B^{(1)} > 0 \Rightarrow$ *Config. H.38*.

β) *The subcase $\chi_A^{(1)} > 0$.* In this case the singularities $M_{1,2}$ are real and we have to decide if they are located either on different branches or on the same branch and, moreover, the position of the hyperbola.

We observe that the conditions $\chi_B^{(1)} < 0$ and $\chi_C^{(1)} < 0$ imply $\mathbf{D} < 0$. Indeed, the conditions $\chi_B^{(1)} < 0$ and $\chi_C^{(1)} < 0$ yield $a > 0$ and $ah < 0$, respectively, and, since $1 - 2ah > 0$, we have $2a(2h - 1) - 1 = 4ah - 2a - 1 < 0$; then $\mathbf{D} < 0$.

So in the case $\chi_B^{(1)} < 0$ we get the following conditions and configurations:

- $\chi_C^{(1)} < 0 \Rightarrow \text{Config. H.75};$
- $\chi_C^{(1)} > 0$ and $\mathbf{D} < 0 \Rightarrow \text{Config. H.74};$
- $\chi_C^{(1)} > 0$ and $\mathbf{D} > 0 \Rightarrow \text{Config. H.48};$
- $\chi_C^{(1)} > 0$ and $\mathbf{D} = 0 \Rightarrow \text{Config. H.64};$

whereas for $\chi_B^{(1)} > 0$ we get

- $\chi_C^{(1)} < 0$ and $\mathbf{D} < 0 \Rightarrow \text{Config. H.73};$ $\chi_C^{(1)} > 0$ and $\mathbf{D} < 0 \Rightarrow \text{Config. H.72};$
- $\chi_C^{(1)} < 0$ and $\mathbf{D} > 0 \Rightarrow \text{Config. H.47};$ $\chi_C^{(1)} > 0$ and $\mathbf{D} > 0 \Rightarrow \text{Config. H.46};$
- $\chi_C^{(1)} < 0$ and $\mathbf{D} = 0 \Rightarrow \text{Config. H.66};$ $\chi_C^{(1)} > 0$ and $\mathbf{D} = 0 \Rightarrow \text{Config. H.65}.$

$\gamma)$ The subcase $\chi_A^{(1)} = 0$. Due to the condition (123), the condition $\chi_A^{(1)} = 0$ implies $Z_1 = 0$ and hence $a = 1/(2h)$. In this case the points $M_{1,2}$ collapse and we have a double point on the hyperbola. For systems (12) with $a = 1/(2h)$ we calculate

$$\chi_C^{(1)} = \frac{35}{2^{17}} (h-1)^4 (2h-1)^2 (2h+1)^2 (3h-1)^2,$$

$$\mathbf{T} = \frac{3}{2^{10}h} (h-1)(2h-1)^4 y^2 [x^2 + 4h(h-1)y^2]^2.$$

Due to (21), we have $\chi_C^{(1)} > 0$ and $\text{sign}(\mathbf{T}) = \text{sign}(h(h-1))$, therefore according to Proposition 1, besides the double point on the hyperbola, we could have two simple points on the invariant line $y = 0$.

We observe that the condition $\chi_B^{(1)} > 0$ implies $\mathbf{T} > 0$. Indeed, if $\chi_B^{(1)} > 0$ we have $a < 0$ and, since $a = 1/(2h)$ (i.e. $h < 0$), we obtain $h(h-1) > 0$; then $\mathbf{T} > 0$.

So we arrive at the configuration *Config. H.67* if $\chi_B^{(1)} < 0$ and $\mathbf{T} < 0$; *Config. H.43* if $\chi_B^{(1)} < 0$ and $\mathbf{T} > 0$; and *Config. H.42* if $\chi_B^{(1)} > 0$.

$\mathbf{a}_2)$ The case $\mu_0 = 0$. Then $h(2h-1) = 0$ and considering the condition (21) we get $h = 0$. In this case one of the singular point located on the hyperbola has gone to infinity and collapsed with $[0, 1, 0]$ (since $\mu_1 = x/4$, see Lemma 1). The second singularity on the hyperbola has the coordinates $(-2, -a/2)$, whereas the coordinates of the singularities $M_{3,4}(x_{3,4}, y_{3,4})$ located on the invariant line $y = 0$ remain the same. Since for systems (20) with $h = 0$ we have $\mathbf{D} = -3a^2(2a+1)$ we obtain $\text{sign}(\mathbf{D}) = \text{sign}(2a+1)$.

We observe that in the case $\chi_B^{(1)} < 0$, we have $a > 0$ and hence $\mathbf{D} = 2a+1 > 0$, which implies the existence of two real simple singularities on $y = 0$ and we obtain the configuration shown in *Config. H.70*. Now, in the case $\chi_B^{(1)} > 0$, we obtain the following conditions and configurations: *Config. H.71* if $\mathbf{D} < 0$; *Config. H.41* if $\mathbf{D} > 0$; and *Config. H.55* if $\mathbf{D} = 0$.

$\mathbf{b)}$ The possibility $\chi_E^{(1)} = 0$. In this case we obtain $a = 1/(g+h)^2$ and this leads to the systems

$$\frac{dx}{dt} = \frac{2h-1}{(g+h)^2} + x + gx^2 + (h-1)xy, \quad \frac{dy}{dt} = \frac{2g-1}{(g+h)^2} - y + (g-1)xy + hy^2 \quad (22)$$

possessing the following invariant line and invariant hyperbola

$$x - y + 2/(g + h) = 0, \quad \Phi(x, y) = \frac{1}{(g + h)^2} + xy = 0. \quad (23)$$

We claim that the condition $\chi_E^{(1)} = 0$ implies $\mathbf{D} \leq 0$ and $\chi_B^{(1)} < 0$. Indeed, if $\chi_E^{(1)} = 0$, then $a = 1/(g + h)^2$ and in this case we see that

$$\begin{aligned} \chi_B^{(1)} &= -\frac{105(g-1)^2(h-1)^2(g-h)^2(3g-1)^2(3h-1)^2}{8(g+h)^2} < 0, \\ \mathbf{D} &= -\frac{192(g-h)^6(g+h-2)^2(g+h-2gh)^2}{(g+h)^8} \leq 0, \end{aligned}$$

due to condition (21), and this proves our claim.

For the above systems we calculate

$$B_2 = -\frac{648}{(g+h)^4} (g-1)^2(h-1)^2(2g-1)(2h-1)(x-y)^4 \quad (24)$$

and by Lemma 2 for the existence of an invariant line in a direction different from $y = x$ it is necessary $B_2 = 0$.

b₁) *The case $B_2 \neq 0$.* Since $\theta \neq 0$ by Lemma 4 we could not have a couple of parallel invariant lines in the direction $y = x$ and obviously the invariant line $y = x + 2/(g + h)$ is a simple one. As before we consider two subcases: $\mu_0 \neq 0$ and $\mu_0 = 0$.

α) *The subcase $\mu_0 \neq 0$.* Then $gh(g + h - 1) \neq 0$ and systems (22) possess four real singularities $M_i(x_i, y_i)$ with the coordinates

$$\begin{aligned} x_1 &= -\frac{1}{g+h}, \quad y_1 = \frac{1}{g+h}; & x_3 &= -\frac{2h-1}{g+h}, \quad y_3 = \frac{2g-1}{g+h}; \\ x_2 &= -\frac{h}{g(g+h)}, \quad y_2 = \frac{g}{h(g+h)}; & x_4 &= -\frac{2h-1}{(g+h)(g+h-1)}, \quad y_4 = \frac{2g-1}{(g+h)(g+h-1)}. \end{aligned} \quad (25)$$

It could be checked directly that the singularity $M_1(x_1, y_1)$ is a common (tangency) point of the invariant hyperbola and of the invariant line (23). Moreover, the singular point $M_2(x_2, y_2)$ (respectively $M_4(x_4, y_4)$) is located on the hyperbola (respectively on the invariant line), whereas the singularity $M_3(x_3, y_3)$ generically is located outside the invariant hyperbola as well as outside the invariant line.

For systems (22) we calculate

$$\begin{aligned} \chi_A^{(1)} &= -\frac{1}{64}(g-1)^2(h-1)^2(g-h)^2(3g-1)^2(3h-1)^2 Z_1|_{\{a=1/(g+h)^2\}}, \\ \chi_C^{(1)} &= \frac{35}{32}gh(g-1)^4(h-1)^4(g-h)^2(3g-1)^2(3h-1)^2, \\ \chi_D^{(1)} &= -\frac{105}{2(g+h)^2}(g-h)^3(3g-1)(3h-1)(g+h-2gh) \end{aligned} \quad (26)$$

and, due to (123), the condition $\chi_A^{(1)} = 0$ is equivalent to $Z_1 = -(g-h)^2/(g+h)^2 = 0$ and this contradicts the condition (123). So the singular points M_1 and M_2 could not collapse.

We consider two possibilities: $\chi_C^{(1)} < 0$ and $\chi_C^{(1)} > 0$.

α_1) The possibility $\chi_C^{(1)} < 0$. In this case the singularities $M_{1,2}$ are located on different branches of the hyperbola and we need to decide if the singular point M_3 coalesces with the singularities on the hyperbola, and this fact is governed by the polynomial \mathbf{D} . However, this last polynomial could vanish due to the factors $g + h - 2$ and $g + h - 2gh$. Then, according to (26), we need to distinguish the cases $\chi_D^{(1)} \neq 0$ and $\chi_D^{(1)} = 0$.

So we get the configurations *Config. H.60* if $\mathbf{D} \neq 0$; *Config. H.63* if $\mathbf{D} = 0$ and $\chi_D^{(1)} \neq 0$; and *Config. H.69* if $\mathbf{D} = 0$ and $\chi_D^{(1)} = 0$.

α_2) The possibility $\chi_C^{(1)} > 0$. Assume $\chi_C^{(1)} > 0$, i.e. $gh > 0$. Then, by Lemma 8, both singularities $M_{1,2}$ are located on the same branch of hyperbola. It is clear that the reciprocal position of the singularities M_2 (located on the hyperbola) and M_4 (located on the invariant line) with respect to the tangency point M_1 of the hyperbola and the invariant line (23), define different configurations. More exactly the type of the configuration depends on the sign of the expression:

$$(x_1 - x_2)(x_1 - x_4) = \frac{(g - h)^2}{g(g + h - 1)(g + h)^2}$$

and hence we need $\text{sign}(g(g + h - 1))$ when $gh > 0$. We calculate

$$\chi_F^{(1)} = (g + h)(g + h - 1)(g - 1)^4(h - 1)^4(g - h)^2(3g - 1)^2(3h - 1)^2/256$$

and, since in the case $gh > 0$ we have $\text{sign}(g) = \text{sign}(g + h)$, we deduce that

$$\text{sign}(\chi_F^{(1)}) = \text{sign}((g + h)(g + h - 1)) = \text{sign}(g(g + h - 1)).$$

We observe that the conditions $\chi_C^{(1)} > 0$ and $\chi_F^{(1)} < 0$ imply $\mathbf{D} \neq 0$ (i.e. $\mathbf{D} < 0$). Indeed, if we suppose $\mathbf{D} = 0$, then $(g + h - 2)(g + h - 2gh) = 0$. In the case $g = 2 - h$, we have

$$\chi_F^{(1)} = (h - 1)^{10}(3h - 5)^2(3h - 1)^2/32 > 0,$$

due to (21), which contradicts the condition $\chi_F^{(1)} < 0$. On the other hand, if $g = h/(2h - 1)$, we have

$$\chi_F^{(1)} = \frac{1}{32(2h - 1)^{10}} h^4(h - 1)^{10}(h + 1)^2(3h - 1)^2(1 - 2h + 2h^2) > 0,$$

due to (21), which again contradicts the condition $\chi_F^{(1)} < 0$. So we detect that in the case $\chi_C^{(1)} < 0$ we obtain the configuration *Config. H.61*.

In the case $\chi_C^{(1)} > 0$, the polynomial \mathbf{D} could vanish and we need to detect to which singular points M_2 or M_4 the singularity M_3 collapses. So we get the following conditions and configurations: *Config. H.59* if $\mathbf{D} \neq 0$; *Config. H.62* if $\mathbf{D} = 0$ and $\chi_D^{(1)} \neq 0$; and *Config. H.68* if $\mathbf{D} = 0$ and $\chi_D^{(1)} = 0$.

β) The subcase $\mu_0 = 0$. Then $gh(g + h - 1) = 0$ and, by Lemma 1, at least one finite singularity has gone to infinity and collapsed with an infinite singular point. Since for systems (22) we have $\chi_C^{(1)} = 0$ if and only if $gh = 0$ (see (26)), we consider two possibilities: $\chi_C^{(1)} \neq 0$ and $\chi_C^{(1)} = 0$.

β_1) The possibility $\chi_C^{(1)} \neq 0$. Then the condition $\mu_0 = 0$ implies $g + h - 1 = 0$, i.e. $g = 1 - h$ and considering the coordinates (25) of the finite singularities of systems (22) we observe that the

singular point M_4 located on the invariant line has gone to infinity and collapsed with the singularity $[1, 1, 0]$. In this case calculation yields

$$\begin{aligned}\chi_A^{(1)} &= h^2(h-1)^2(2h-1)^4(3h-1)^2(3h-2)^2/64, \\ \chi_B^{(1)} &= -105h^2(h-1)^2(2h-1)^2(3h-1)^2(3h-2)^2/8, \\ \chi_C^{(1)} &= 35h^5(1-h)^5(2h-1)^2(3h-1)^2(3h-2)^2/32, \\ \mathbf{D} &= -192(2h-1)^6(1-2h+2h^2)^2,\end{aligned}$$

and by (21) we have $\chi_A^{(1)} > 0$, $\chi_B^{(1)} > 0$ and $\mathbf{D} < 0$. Moreover, since by Remark 8 the condition $\mathbf{R} \neq 0$ holds, then according to Proposition 1 all three finite singularities are distinct. This means that the singularities located on the hyperbola are simple and belong to different branches (respectively of the same branch) of the hyperbola if $\chi_C^{(1)} < 0$ (respectively $\chi_C^{(1)} > 0$). As a result we get configurations *Config. H.56* if $\chi_C^{(1)} < 0$ and *Config. H.57* if $\chi_C^{(1)} > 0$.

β_2) The possibility $\chi_C^{(1)} = 0$. Then $gh = 0$ (this implies $\mu_0 = 0$) and we have $g^2 + h^2 \neq 0$ due to $g - h \neq 0$. Considering Remark 7, without loss of generality, we may assume $g = 0$. In this case, the singularity M_2 located on the hyperbola (23) has gone to infinity and collapsed with the point $[1, 0, 0]$. Since by Remark 8 we have $\mu_1 \neq 0$, then according to Lemma 1 other three finite singular points remain on the finite part of the phase plane.

It is clear that depending on the position of the singular point M_4 (located on the invariant line (23)) with respect to the vertical line $x = x_1$ we get different configurations. So this distinction is governed by the sign of the expression $x_4 - x_1 = 1/(1-h)$. Moreover, since in this case we have the invariant line $x - y + 2/h = 0$, its position depends on the sign of h . Then we need to control the sign $(h(1-h))$. Thus, we calculate

$$\chi_F^{(1)} = h^3(h-1)^5(3h-1)^2/256, \quad \mathbf{D} = -192(h-2)^2$$

and we have $\text{sign}(h(1-h)) = -\text{sign}(\chi_F^{(1)})$.

It is clear that, in the case $\chi_F^{(1)} < 0$, we have $\mathbf{D} \neq 0$ and, since the condition $\mathbf{R} \neq 0$ holds (see Remark 8), Proposition 1 assures us that all three finite singularities are distinct if $\mathbf{D} \neq 0$. So we arrive at the configuration given by *Config. H.50*.

Now, in the case $\chi_F^{(1)} > 0$, the polynomial \mathbf{D} could vanish and we obtain the configuration *Config. H.51* if $\mathbf{D} \neq 0$ and *Config. H.54* if $\mathbf{D} = 0$.

b_2) The case $B_2 = 0$. Considering (24) and the condition (123) we obtain $g = 1/2$ and this leads to the 1-parameter family of systems

$$\frac{dx}{dt} = \frac{4(2h-1)}{(2h+1)^2} + x + \frac{x^2}{2} + (h-1)xy, \quad \frac{dy}{dt} = -y(2+x-2hy)/2, \quad (27)$$

for which the condition $\theta\beta_1\beta_2 \neq 0$ gives

$$(h-1)(2h+1)(2h-1)(3h-1)(6h-5) \neq 0. \quad (28)$$

These systems possess two invariant lines and a hyperbola

$$x - y + \frac{4}{2h+1} = 0, \quad y = 0, \quad \Phi(x, y) = \frac{4}{(2h+1)^2} + xy = 0.$$

as well as the following singularities $M_i(x_i, y_i)$:

$$\begin{aligned} x_1 &= -\frac{2}{2h+1}, \quad y_1 = \frac{2}{2h+1}; & x_3 &= \frac{2(1-2h)}{2h+1}, \quad y_3 = 0; \\ x_2 &= -\frac{4h}{2h+1}, \quad y_2 = \frac{1}{h(2h+1)}; & x_4 &= -\frac{4}{2h+1}, \quad y_4 = 0. \end{aligned} \quad (29)$$

We observe that due to the condition (28) all singularities are located on the finite part of the phase plane, except the singular point M_2 which could go to infinity in the case $h = 0$. For the above systems we calculate

$$\chi_C^{(1)} = 35h(h-1)^4(2h-1)^2(3h-1)^2/16384$$

and we analyze the subcases $\chi_C^{(1)} < 0$, $\chi_C^{(1)} > 0$ and $\chi_C^{(1)} = 0$.

α) *The subcase $\chi_C^{(1)} < 0$.* Then $h < 0$ and it implies

$$\mu_0 = h(2h-1)/4 \neq 0, \quad \mathbf{D} = -\frac{48}{(2h+1)^8} (2h-3)^2(2h-1)^6 \neq 0.$$

Since the singular points on the hyperbola are located on different branches, we arrive at the unique configuration *Config. H.84*.

β) *The subcase $\chi_C^{(1)} > 0$.* Then $h > 0$ (this implies again $\mu_0 \neq 0$) and the singularities on the hyperbola are located on the same branch. Thus, it is necessary to distinguish the position of M_2 on the hyperbola with relation to M_1 , which is the intersection point of the hyperbola and the invariant line $x - y + 4/(2h+1) = 0$, and M_4 , which is the intersection point of the two invariant lines, as well as the position of the singularities M_3 and M_4 on the invariant line $y = 0$. We calculate

$$(x_1 - x_2)(x_1 - x_4) = \frac{4(2h-1)}{(2h+1)^2}, \quad (x_4 - x_3) = \frac{2(2h-3)}{2h+1}$$

and hence $\text{sign}(2h-1)$ (respectively $\text{sign}(2h-3)$) will describe the position of the singularity M_2 on the hyperbola (respectively the position of the singularity M_3 on the invariant line $y = 0$). We calculate

$$\chi_F^{(1)} = 2^{-18} (2h-1)^3(2h+1)(h+1)^4(3h-1)^2, \quad \chi_G^{(1)} = (2h-3)(h+1)/8$$

and, due to (28) and since $h > 0$, we obtain $\text{sign}(2h-1) = \text{sign}(\chi_F^{(1)})$ and $\text{sign}(2h-3) = \text{sign}(\chi_G^{(1)})$.

We observe that the condition $\chi_G^{(1)} = 0$ yields $h = 3/2$ and this implies $\mathbf{D} = 0$. In this sense, we obtain the following conditions and configurations:

- $\chi_F^{(1)} < 0 \Rightarrow \text{Config. H.86}$;
- $\chi_F^{(1)} > 0$ and $\chi_G^{(1)} < 0 \Rightarrow \text{Config. H.85}$;
- $\chi_F^{(1)} > 0$ and $\chi_G^{(1)} > 0 \Rightarrow \text{Config. H.83}$;
- $\chi_F^{(1)} > 0$ and $\chi_G^{(1)} = 0 \Rightarrow \text{Config. H.81}$;

γ) *The subcase $\chi_C^{(1)} = 0$.* Then $h = 0$ (this implies $\mu_0 = 0$) and the singularity M_2 has gone to infinity and collapsed with $[0, 1, 0]$. As a result we get *Config. H.82*.

3.1.1.2 *The case $\beta_2 = 0$.* Since $\beta_1 \neq 0$ (i.e. $c \neq 0$) we get $(g-h)(3g+3h-4) = 0$. On the other hand, for systems (10) we have

$$\beta_3 = -c(g-h)(g-1)(h-1)/4$$

and we consider two possibilities: $\beta_3 \neq 0$ and $\beta_3 = 0$.

3.1.1.2.1 *The possibility $\beta_3 \neq 0$.* In this case we have $g-h \neq 0$ and the condition $\beta_2 = 0$ yields $3g+3h-4 = 0$, i.e. $g = 4/3 - h$. In this case, for systems (10), we calculate

$$\begin{aligned} \gamma_3 &= 7657c(h-1)^3(3h-1)^3[a(5-6h) - 3b(2h-1)], \\ \beta_3 &= -c(h-1)(3h-2)(3h-1)/18, \quad \mathcal{R}_1 = (a-b)c(h-1)^3(3h-1)^3/6. \end{aligned}$$

Without loss of generality, we may assume $2h-1 \neq 0$, otherwise via the change $(x, y, t, a, b, c) \mapsto (y, x, t, b, a, -c)$ we could bring systems (10) with $h = 1/2$ to the same systems with $h = 5/6$. Therefore, due to $\beta_3 \neq 0$, the condition $\gamma_3 = 0$ yields $b = a(5-6h)/[3(2h-1)]$ and since $c \neq 0$ we may assume $c = 1$ due to the rescaling $(x, y, t) \mapsto (cx, cy, t/c)$.

We remark that the condition $\gamma_3 = 0$ could be written as $a = a_1(2h-1)$ and $b = a_1(5-6h)/3$. So setting the old parameter a instead of a_1 , we arrive at the 2-parameter family of systems

$$\frac{dx}{dt} = 3a(2h-1) + x + \frac{4-3h}{3}x^2 + (h-1)xy, \quad \frac{dy}{dt} = \frac{a(5-6h)}{3} - y + \frac{1-3h}{3}xy + hy^2, \quad (30)$$

for which the condition $\theta\beta_1\beta_3\mathcal{R}_1 \neq 0$ is equivalent to the condition

$$a(h-1)(3h-1)(3h-2) \neq 0. \quad (31)$$

Moreover, these systems possess the same invariant hyperbola (122).

Observation 2. *We observe that the family of systems (30) is in fact a subfamily of systems (12) under the relation $g = 4/3 - h$. Moreover, if we present the condition (123) in the form $F(a, g, h)(3g+3h-4) \neq 0$, then in the case $g = 4/3 - h$, the condition (31) is equivalent to $F(a, g, h) \neq 0$. We also point out that the condition $g = 4/3 - h$ does not imply the vanishing of any of the invariants $\chi_A^{(1)}, \chi_B^{(1)}, \dots, \chi_G^{(1)}$. Hence, all the configurations of systems (30) are the configurations of systems (12) determined by the same invariant conditions.*

Considering this observation, we could join the conditions defining the family (12) (i.e. $\eta > 0$, $\theta\beta_1\beta_2 \neq 0$) with the conditions which define the subfamily (30) (i.e. $\eta > 0$, $\theta\beta_1 \neq 0$, $\beta_2 = 0$ and $\beta_3 \neq 0$). More precisely, the conditions defining both such families of systems are $\beta_2^2 + \beta_3^2 \neq 0$ and (\mathfrak{C}_1) , where

$$(\mathfrak{C}_1) : (\beta_2\mathcal{R}_1 \neq 0) \cup (\beta_2 = \gamma_3 = 0 \cap \beta_3 \neq 0).$$

3.1.1.2.2 *The possibility $\beta_3 = 0$.* Due to $\beta_1 \neq 0$ (i.e. $(g-1)(h-1) \neq 0$), we get $g = h$. In this case, we calculate

$$\begin{aligned} \gamma_2 &= 6300h(h-1)^4(3h-2)(3h-1)^2\mathcal{B}_1, \\ \theta &= -h(h-1)^2, \quad \beta_1 = -(h-1)^2(3h-1)^2/4, \\ \beta_4 &= 2h(3h-2), \quad \beta_5 = -2h^2(2h-1). \end{aligned}$$

We shall consider two cases: $\beta_4 \neq 0$ and $\beta_4 = 0$.

a) *The case $\beta_4 \neq 0$.* So the condition $\gamma_2 = 0$ implies $\mathcal{B}_1 = 0$ and by Theorem 3 the condition $\beta_5 \neq 0$ is necessary for the existence of hyperbola. Hence, we arrive at the particular case of systems (12) when $g = h$, i.e. we get the systems

$$\frac{dx}{dt} = a(2h - 1) + x + hx^2 + (h - 1)xy, \quad \frac{dy}{dt} = a(2h - 1) - y + (h - 1)xy + hy^2 \quad (32)$$

with the condition

$$ah(h - 1)(2h - 1)(3h - 1)(3h - 2) \neq 0. \quad (33)$$

These systems possess the invariant line and hyperbola

$$1 + h(x - y) = 0, \quad \Phi(x, y) = a + xy = 0.$$

Since $\mu_0 = h^2(2h - 1) \neq 0$ (see (33)), then the systems have finite singularities $M_i(x_i, y_i)$ of total multiplicity 4:

$$\begin{aligned} x_{1,2} &= -\frac{1 \pm \sqrt{1 - 4ah^2}}{2h}, & y_{1,2} &= \frac{1 \mp \sqrt{1 - 4ah^2}}{2h}, \\ x_{3,4} &= \frac{-1 \pm \sqrt{1 + 4a - 8ah}}{2}, & y_{3,4} &= \frac{1 \mp \sqrt{1 + 4a - 8ah}}{2}, \end{aligned}$$

We detect that the singularities $M_{1,2}$ are located on both the hyperbola and the straight line. These singular points are located on different branches (respectively on the same branch) of the hyperbola if only if $x_1x_2 < 0$ (respectively $x_1x_2 > 0$), where $x_1x_2 = a$. Moreover, these singularities are real if $1 - 4ah^2 > 0$, they are complex if $1 - 4ah^2 < 0$ and they coincide if $1 - 4ah^2 = 0$.

On the other hand, we calculate

$$\chi_A^{(2)} = 2h^2(2h - 1)^2(3h - 1)^2(1 - 4ah^2), \quad \chi_B^{(2)} = -a(h - 1)^2(2h - 1)^2(3h - 1)^4/4$$

and, due to the condition (33), we have $\text{sign}(1 - 4ah^2) = \text{sign}(\chi_A^{(2)})$ (if $1 - 4ah^2 \neq 0$) and $\text{sign}(x_1x_2) = -\text{sign}(\chi_B^{(2)})$.

We observe that at least one of the singular points $M_{3,4}$ could be located either on the invariant hyperbola or on the invariant straight line. Next we determine the conditions for this to happen. We calculate

$$\begin{aligned} \Phi(x, y)|_{\{x=x_{3,4}, y=y_{3,4}\}} &= (-1 + 4ah \pm \sqrt{1 + 4a - 8ah}) \equiv \Omega'_{3,4}(a, h), \\ [1 + h(x - y)]|_{\{x=x_{3,4}, y=y_{3,4}\}} &= 1 + h(-1 \pm \sqrt{1 + 4a - 8ah}) \equiv \Theta_{3,4}(a, h). \end{aligned}$$

So M_3 or M_4 could be located on the invariant hyperbola (respectively invariant line) if and only if $\Omega'_3\Omega'_4 = 0$ (respectively $\Theta_3\Theta_4 = 0$). So we have

$$\Omega'_3\Omega'_4 = -a(1 - 4ah^2) = 0, \quad \Theta_3\Theta_4 = (1 - 2h)(1 - 4ah^2) = 0$$

if and only $1 - 4ah^2 = 0$ (due to the condition (33)).

Thus, in the case $\chi_A^{(2)} \neq 0$ we arrive at the configuration given by *Config. H.37* if $\chi_A^{(2)} < 0$; *Config. H.52* if $\chi_A^{(2)} > 0$ and $\chi_B^{(2)} < 0$; and *Config. H.53* if $\chi_A^{(2)} > 0$ and $\chi_B^{(2)} > 0$.

Assume now $\chi_A^{(2)} = 0$, i.e. $1 - 4ah^2 = 0$. Due to the condition (33) we have $h \neq 0$ and hence $a = 1/(4h^2)$. It could be easily observed that in this case the singular points M_2 and M_3 coalesce

with the singularity M_1 and this point becomes a triple point of contact of the invariant hyperbola and invariant line. We remark that this point of contact could not be of multiplicity 4 because in this case we have

$$\mu_0 = h^2(2h - 1) \neq 0, \quad \mathbf{D} = \mathbf{T} = \mathbf{P} = 0, \quad \mathbf{R} = 3h^2(h - 1)^2(2h - 1)^2(x + y)^2 \neq 0,$$

due to the condition (33). Thus, in the case $\chi_A^{(2)} = 0$ we get the configuration given by *Config. H.45*.

b) The case $\beta_4 = 0$. Then, due to $\theta \neq 0$, we get $h = 2/3$ and we obtain a family of systems which is a subfamily of systems (32) setting $h = 2/3$. Since in this case we have

$$\chi_A^{(2)} = 8(9 - 16a)/729, \quad \chi_B^{(2)} = -a/324,$$

it is clear that we obtain again the same four configurations as for the family (33) with the same invariant conditions. As earlier we could join the cases $\beta_4 \neq 0$ and $\beta_4 = 0$. More precisely, the conditions defining the corresponding families of systems are

$$(\mathfrak{C}_2) : (\beta_4\beta_5\mathcal{R}_2 \neq 0) \cup (\beta_4 = \gamma_3 = 0, \mathcal{R}_2 \neq 0).$$

3.1.2 The possibility $\beta_1 = 0$

Considering (11) and the condition $\theta \neq 0$, we get $c(3g - 1)(3h - 1) = 0$. On the other hand, for systems (10) we calculate

$$\beta_6 = -c(g - 1)(h - 1)/2$$

and we shall consider two cases: $\beta_6 \neq 0$ and $\beta_6 = 0$.

3.1.2.1 The case $\beta_6 \neq 0$. Then $c \neq 0$ (as before we could assume $c = 1$ due to a rescaling) and the condition $\beta_1 = 0$ implies $(3g - 1)(3h - 1) = 0$. Therefore, due to Remark 7, we may assume $h = 1/3$ and this leads to the following 3-parameter family of systems

$$\frac{dx}{dt} = a + x + gx^2 - 2xy/3, \quad \frac{dy}{dt} = b - y + (g - 1)xy + y^2/3, \quad (34)$$

which is a subfamily of (10).

For these systems we calculate

$$\begin{aligned} \gamma_4 &= 16(g - 1)^2(3g - 1)^2 [3a(2g - 1) + b] [(3g + 1)^2(b - 2a + 6ag) + 6(1 - 3g)] / 243, \\ \beta_6 &= (g - 1)/3, \quad \beta_2 = (1 - g)(3g - 1)/2, \quad \mathcal{R}_3 = a(3g - 1)^3/18. \end{aligned}$$

3.1.2.1.1 The subcase $\beta_2 \neq 0$. Then $3g - 1 \neq 0$ and, in order to have $\gamma_4 = 0$, we must have $[3a(2g - 1) + b] [(3g + 1)^2(b - 2a + 6ag) + 6(1 - 3g)] = 0$.

We claim that systems (34) with $(3g + 1)^2(b - 2a + 6ag) + 6(1 - 3g) = 0$ (i.e. $b = 2(3g - 1)(3 - a - 6ag - 9ag^2)/(3g + 1)^2$) could be brought to the same systems with $b = 3a(1 - 2g)$ via an affine transformation. Indeed, due to $\theta \neq 0$ (i.e. $(3g + 1)(g - 1) \neq 0$), we may apply the affine transformation

$$x_1 = \frac{3g + 1}{3(1 - g)}x, \quad y_1 = \frac{3g + 1}{3(1 - g)}(x - y) + \frac{2}{1 - g}, \quad t_1 = \frac{3(g - 1)}{3g + 1}t, \quad (35)$$

and we arrive at the systems

$$\frac{dx_1}{dt_1} = a_1 + x_1 + g_1 x_1^2 - 2x_1 y_1/3, \quad \frac{dy_1}{dt_1} = b_1 - y_1 + (g_1 - 1)x_1 y_1 + y_1^2/3,$$

where $b_1 = -3a_1(2g_1 - 1)$, $a_1 = -a(3g + 1)^2/[9(g - 1)^2]$ and $g_1 = (2 - 3g)/3$. This completes the proof of our claim.

Thus, in what follows, we consider the following family of systems

$$\frac{dx}{dt} = a + x + gx^2 - 2xy/3, \quad \frac{dy}{dt} = -3a(2g - 1) - y + (g - 1)xy + y^2/3, \quad (36)$$

with the condition

$$a(g - 1)(3g - 1)(3g + 1) \neq 0. \quad (37)$$

According to Theorem 3, these systems possess either one or two invariant hyperbolas if either $\delta_1 \neq 0$ or $\delta_1 = 0$, respectively, where $\delta_1 = (3g - 1)[6(1 - 3g) + a(3g + 1)^2]/18$.

a) *The possibility $\delta_1 \neq 0$.* Then systems (36) possess the unique invariant hyperbola

$$\Phi(x, y) = 3a - xy = 0. \quad (38)$$

For systems (36) we calculate

$$B_1 = 8a^2(g - 1)^2(2g - 1)(3g - 1)[3 + a(3g + 1)^2]/27. \quad (39)$$

α_1) *The case $B_1 \neq 0$.* In this case, due to (37), we have $(2g - 1)[3 + a(3g + 1)^2] \neq 0$. For systems (36) we calculate $\mu_0 = g(3g - 2)/9$ and we consider two possibilities: $\mu_0 \neq 0$ and $\mu_0 = 0$.

α) *The subcase $\mu_0 \neq 0$.* In this case the systems have finite singularities of total multiplicity 4 with coordinates $M_i(x_i, y_i)$:

$$x_{1,2} = \frac{-1 \pm \sqrt{1 + 4ag}}{2g}, \quad y_{1,2} = \frac{3(1 \pm \sqrt{1 + 4ag})}{2},$$

$$x_{3,4} = \frac{1 \pm \sqrt{1 - 8a + 12ag}}{2(3g - 2)}, \quad y_{3,4} = \frac{3(2g - 1)(1 \pm \sqrt{1 - 8a + 12ag})}{2(3g - 2)}.$$

We detect that the singularities $M_{1,2}$ are located on the invariant hyperbola. More exactly, these singular points are located on different branches (respectively on the same branch) of the hyperbola if only if $x_1 x_2 < 0$ (respectively $x_1 x_2 > 0$), where $x_1 x_2 = -a/g$. Moreover, these singularities are real if $1 + 4ag > 0$, complex if $1 + 4ag < 0$ or they coincide if $1 + 4ag = 0$.

On the other hand, we calculate

$$\chi_A^{(3)} = \frac{7713280}{243} (1 + 4ag)[6(1 - 3g) + a(3g + 1)^2]^2,$$

$$\chi_B^{(3)} = \frac{164798932}{81} a(g - 1)^2(3g - 1)^2[6(1 - 3g) + a(3g + 1)^2]^2,$$

$$\chi_C^{(3)} = -\frac{66560}{9} ag[6(1 - 3g) + a(3g + 1)^2]^2,$$

and, due to the condition (37), we have $\text{sign}(\chi_A^{(3)}) = \text{sign}(1 + 4ag)$ (if $1 + 4ag \neq 0$) and $\text{sign}(\chi_C^{(3)}) = \text{sign}(x_1x_2)$.

We point out that at least one of the singular points $M_{3,4}$ could be located on the invariant hyperbola. Next we determine the conditions for this to happen. We calculate

$$\Phi(x, y)|_{\{x=x_{3,4}, y=y_{3,4}\}} = \frac{3[2a(g-1)(3g-2) - (2g-1)(1 \pm \sqrt{1-8a+12ag})]}{2(3g-2)^2} \equiv \Omega''_{3,4}(a, g, h).$$

It is clear that at least one of the singular points M_3 or M_4 belongs to the hyperbola (137) if and only if $\Omega''_3\Omega''_4 = 0$. So we have

$$\Omega''_3\Omega''_4 = \frac{9a[a(g-1)^2 - 2g + 1]}{(3g-2)^2} = 0$$

and, since

$$\chi_D^{(3)} = \frac{736}{81}(3g-1)[a(g-1)^2 - 2g + 1][6(1-3g) + a(3g+1)^2],$$

we deduce that at least one of the singular points $M_{3,4}$ belongs to the hyperbola if and only if $\chi_D^{(3)} = 0$.

α_1) The possibility $\chi_A^{(3)} < 0$. So we have no real singularities located on the invariant hyperbolas and we arrive at the configurations given by *Config. H.1* if $\chi_B^{(3)} < 0$ and *Config. H.2* if $\chi_B^{(3)} > 0$.

α_2) The possibility $\chi_A^{(3)} > 0$. In this case we have two real singularities located on the hyperbola and we need to decide if they are located either on different branches or on the same branch of the invariant hyperbola and also if at least one of the singular points $M_{3,4}$ will belong to the hyperbola.

i) The case $\chi_D^{(3)} \neq 0$. Then $a(g-1)^2 - 2g + 1 \neq 0$ and on the hyperbola there are two simple real singularities (namely $M_{1,2}$) and we arrive at the conditions and configurations given by:

- $\chi_C^{(3)} < 0$ and $\chi_B^{(3)} < 0 \Rightarrow \text{Config. H.17};$
- $\chi_C^{(3)} < 0$ and $\chi_B^{(3)} > 0 \Rightarrow \text{Config. H.19};$
- $\chi_C^{(3)} > 0$ and $\chi_B^{(3)} < 0 \Rightarrow \text{Config. H.16};$
- $\chi_C^{(3)} > 0$ and $\chi_B^{(3)} > 0 \Rightarrow \text{Config. H.18}.$

ii) The case $\chi_D^{(3)} = 0$. In this case, due to $B_1 \neq 0$ and (37), we obtain $a = (2g-1)/(g-1)^2$. Then, considering Proposition 1, we calculate

$$\mathbf{D} = 0, \quad \mathbf{T} = -\frac{(5g-3)^2}{2187(g-1)^4}(3g-1)^2(3gx-y)^2[3(2g-1)x-y]^2[3g(g-1)x+2(2g-1)y]^2.$$

ii.1) The subcase $\mathbf{T} \neq 0$. Then $\mathbf{T} < 0$, $\chi_A^{(3)} > 0$ and, according to Proposition 1, in this case systems (12) possess one double and two simple real finite singularities. More exactly, we detect that one of the singular points M_3 or M_4 collapses with a singular point located on the hyperbola, whereas the other one remains outside the hyperbola. Then, we obtain the conditions and configurations as follow:

- $\chi_C^{(3)} < 0$ and $\chi_B^{(3)} < 0 \Rightarrow \text{Config. H.21};$
- $\chi_C^{(3)} < 0$ and $\chi_B^{(3)} > 0 \Rightarrow \text{Config. H.23};$
- $\chi_C^{(3)} > 0 \Rightarrow \text{Config. H.20},$

in which in the last case the condition $\chi_C^{(3)} > 0$ implies $\chi_B^{(3)} < 0$, because $\mathbf{T} < 0$ yields $0 < g < 1/2$ and, for these values of g combined with the condition $\chi_C^{(3)} > 0$, we have $a < 0$ and hence $\chi_B^{(3)} < 0$.

ii.2) *The subcase $\mathbf{T} = 0$.* In this case, due to the conditions (37) and $\mu_0 \neq 0$, the equality $\mathbf{T} = 0$ yields $g = 3/5$ and hence $\chi_C^{(3)} = -416000/3 < 0$, which leads to configuration given by *Config. H.26*.

α_3) *The possibility $\chi_A^{(3)} = 0$.* Due to (37), the condition $\chi_A^{(3)} = 0$ implies $1 + 4ag = 0$ and hence $a = -1/(4g)$. In this case the points $M_{1,2}$ collapse and we have a double point on the hyperbola. In this case we see that

$$\chi_D^{(3)} = \frac{46(3g-1)^3(9g-1)^2}{81g^2} \neq 0$$

and $\delta_1 \neq 0$, due to (37). So, as $\chi_A^{(3)} \neq 0$ no other point could collapse with the double point on the hyperbola, we arrive at the configuration *Config. H.7* if $\chi_B^{(3)} < 0$ and *Config. H.8* if $\chi_B^{(3)} > 0$.

β) *The subcase $\mu_0 = 0$.* We consider the possibilities: $\chi_A^{(3)} < 0$, $\chi_A^{(3)} > 0$ and $\chi_A^{(3)} = 0$.

β_1) *The possibility $\chi_A^{(3)} < 0$.* The singular points on the hyperbola are complex and, since $1 + 4ag < 0$ yields $ag < 0$, we have $g = 2/3$ and then $a < 0$, which is equivalent to $\chi_B^{(3)} < 0$. So we arrive at the configuration given by *Config. H.3*.

β_2) *The possibility $\chi_A^{(3)} > 0$.* Analogously we have $g = 2/3$ and the points on the hyperbola are real. We observe that, due to the condition (37), the equality $\chi_C^{(3)} = 0$ is equivalent to $g = 0$. So we consider two subcases: $\chi_C^{(3)} \neq 0$ and $\chi_C^{(3)} = 0$.

i) *The case $\chi_C^{(3)} \neq 0$.* Then one finite singularity has gone to infinity and collapsed with the point $[1, 1, 0]$. As observed earlier, this must be a singular point located outside the hyperbola which goes to infinity and hence on the finite part of the phase plane of systems (40) there are three singularities, two of which (M_1 and M_2) being located on the hyperbola.

Since the singular points on the hyperbola are real, we have to decide when the third point will belong also to the hyperbola. For systems (36) with $g = 2/3$ we calculate

$$\begin{aligned} \chi_A^{(3)} &= \frac{7713280}{81} (8a+3)(3a-2)^2, & \chi_B^{(3)} &= \frac{164798932}{81} a(3a-2)^2, \\ \chi_C^{(3)} &= -\frac{133120}{3} a(3a-2)^2, & \chi_D^{(3)} &= \frac{736}{243} (a-3)(3a-2). \end{aligned}$$

We observe that $\text{sign}(\chi_B^{(3)}) = -\text{sign}(\chi_C^{(3)})$ and, moreover, $\chi_D^{(3)} = 0$ (i.e. $a = 3$) implies $\chi_C^{(3)} < 0$. So we get the following conditions and configurations:

- $\chi_C^{(3)} < 0$ and $\chi_D^{(3)} \neq 0 \Rightarrow \text{Config. H.32};$
- $\chi_C^{(3)} < 0$ and $\chi_D^{(3)} = 0 \Rightarrow \text{Config. H.34};$

- $\chi_C^{(3)} > 0 \Rightarrow \text{Config. H.29.}$

ii) The case $\chi_C^{(3)} = 0$. Then $g = 0$ and this implies

$$\chi_B^{(3)} = 164798932a(a+6)^2/81, \quad \chi_C^{(3)} = 0, \quad \chi_D^{(3)} = -736(a_1)(a+6)^2/81.$$

So we get the following conditions and configurations:

- $\chi_B^{(3)} < 0$ and $\chi_D^{(3)} \neq 0 \Rightarrow \text{Config. H.9;}$
- $\chi_B^{(3)} < 0$ and $\chi_D^{(3)} = 0 \Rightarrow \text{Config. H.11;}$
- $\chi_B^{(3)} > 0 \Rightarrow \text{Config. H.10,}$

in which in the last case the condition $\chi_B^{(3)} > 0$ (i.e. $a > 0$) implies $\chi_D^{(3)} \neq 0$.

β_3) The possibility $\chi_A^{(3)} = 0$. Due to (37), the condition $\mu_0 = \chi_A^{(3)} = 0$ implies $g(3g-2) = 1+4ag = 0$. Then this yields $g \neq 0$ and hence $g = 2/3$ and $a = -3/8$. In this case the singularities $M_{1,2}$ collapse and we have a double point on the hyperbola. For systems (36) with $a = -3/8$ we calculate

$$\chi_C^{(3)} = 162500 > 0, \quad \chi_D^{(3)} = 575/18 \neq 0.$$

Since $\chi_D^{(3)} \neq 0$, no other point could coalesce with the double point on the hyperbola and we arrive at the configuration *Config. H.14.*

α_2) The case $B_1 = 0$. Thus, according to Lemma 2, the condition $B_1 = 0$ is necessary in order to exist an invariant line of systems (36). Considering (37), the condition $B_1 = 0$ (see (39)) is equivalent to

$$(2g-1)[3+a(3g+1)^2] = 0.$$

On the other hand for these systems we calculate

$$\chi_E^{(3)} = (3g-1)[3+a(3g+1)^2][6(1-3g)+a(3g+1)^2]$$

and we examine two possibilities: $\chi_E^{(3)} \neq 0$ and $\chi_E^{(3)} = 0$.

α) The subcase $\chi_E^{(3)} \neq 0$. In this case we get $g = 1/2$ and this leads to the systems

$$\frac{dx}{dt} = a + x + x^2/2 - 2xy/3, \quad \frac{dy}{dt} = -y(1 + x/2 - y/3), \quad (40)$$

for which the following condition holds (see (37)):

$$a(25a-12) \neq 0. \quad (41)$$

Since the family of systems (40) is a subfamily of (36) (setting $g = 1/2$), the invariant hyperbola remains the same as in (137). Besides this hyperbola, systems (40) possess the invariant line $y = 0$, which is one of the asymptotes of this hyperbola. For the above systems we calculate

$$\mu_0 = -1/36, \quad \chi_E^{(3)} = (25a+12)(25a-12)/192, \quad B_1 = 0, \quad B_2 = -8a(25a+12)y^4.$$

Therefore, we conclude that, due to the conditions $\chi_E^{(3)} \neq 0$ and (41), we obtain $B_2 \neq 0$ and by Lemma 2 we could not have another invariant line in a direction different from $y = 0$. Moreover, due to the condition $\theta \neq 0$ and according to Lemma 4, in the direction $y = 0$ we could not have either a couple of parallel invariant lines or a double invariant line.

Since $\mu_0 \neq 0$, systems (40) possess finite singular points of multiplicity 4 with coordinates $M_i(x_i, y_i)$ ($i=1,2,3,4$):

$$\begin{aligned} x_{1,2} &= -1 \pm \sqrt{2a+1}, & y_{1,2} &= 3(1 \pm \sqrt{2a+1})/2, \\ x_{3,4} &= -1 \pm \sqrt{1-2a}, & y_{3,4} &= 0. \end{aligned}$$

We recall that the singular points $M_{1,2}$ are located on the hyperbola and that the singularities $M_{3,4}$ are located on the invariant line $y = 0$.

On the other hand for systems (40) we calculate

$$\begin{aligned} \chi_A^{(3)} &= \frac{482080}{243}(2a+1)(25a-12)^2, & \mathbf{D} &= a^2(2a-1)(2a+1)/3, \\ \chi_B^{(3)} &= \frac{41199733}{5184}a(25a-12)^2, & \chi_C^{(3)} &= -\frac{2080}{9}a(25a-12)^2 \end{aligned}$$

and then the invariant polynomials $\chi_A^{(3)}$ and \mathbf{D} govern the types of the above singular points (i.e. are they real or complex or coinciding), whereas the invariant polynomials $\chi_B^{(3)}$ and $\chi_C^{(3)}$ are responsible respectively for the position of the hyperbola and the location of the real singularities on it (i.e. on the same branch or on the different ones).

α_1) *The possibility $\chi_A^{(3)} < 0$.* Then the singularities $M_{1,2}$ (located on the hyperbola) are complex. Since $\chi_A^{(3)} < 0$, we obtain $\chi_B^{(3)} < 0$ and $\mathbf{D} > 0$, and by Proposition 1 the singularities on the invariant line are real and distinct. So we get the configuration given by *Config. H.49*.

α_2) *The possibility $\chi_A^{(3)} > 0$.* In this case the singularities $M_{1,2}$ are real and they are located on different branches (respectively on the same branch) of the hyperbola if $\chi_C^{(3)} < 0$ (respectively $\chi_C^{(3)} > 0$). We observe that the conditions $\chi_A^{(3)} > 0$ and $\mathbf{D} \geq 0$ imply $a \geq 1/2$ and then $\chi_B^{(3)} > 0$ and $\chi_C^{(3)} < 0$. Moreover, the conditions $\chi_A^{(3)} > 0$ and $\chi_B^{(3)} < 0$ yield $-1/2 < a < 0$ and then $\mathbf{D} < 0$ and $\chi_C^{(3)} > 0$. Therefore, we arrive at the following conditions and configurations:

- $\chi_B^{(3)} < 0 \Rightarrow$ *Config. H.74*;
- $\chi_B^{(3)} > 0$ and $\mathbf{D} < 0 \Rightarrow$ *Config. H.73*;
- $\chi_B^{(3)} > 0$ and $\mathbf{D} > 0 \Rightarrow$ *Config. H.47*;
- $\chi_B^{(3)} > 0$ and $\mathbf{D} = 0 \Rightarrow$ *Config. H.66*.

α_3) *The possibility $\chi_A^{(3)} = 0$.* Due to the condition (41), the condition $\chi_A^{(3)} = 0$ implies $a = -1/2$. In this case the points $M_{1,2}$ collapse and we have a double point on the hyperbola. For systems (40) with $a = -1/2$ we calculate

$$\chi_B^{(3)} = 41199733/41472 > 0, \quad \mathbf{T} = -(3x-2y)^2(9x^2-24xy+8y^2)^2/4478976 < 0.$$

So, according to Proposition 1, besides the double point on the hyperbola, we have two simple real singular points on the invariant line $y = 0$ and we get the configuration given by *Config. H.67*.

β) The subcase $\chi_E^{(3)} = 0$. In this case we obtain $a = -3/(3g+1)^2$ and this leads to the systems

$$\frac{dx}{dt} = -\frac{3}{(3g+1)^2} + x + gx^2 - 2xy/3, \quad \frac{dy}{dt} = \frac{9(2g-1)}{(3g+1)^2} - y + (g-1)xy + y^2/3 \quad (42)$$

with the conditions

$$(g-1)(3g-1)(3g+1)(6g-1) \neq 0. \quad (43)$$

Moreover, systems (42) possess the following invariant line and invariant hyperbola

$$x - y + 6/(3g+1) = 0, \quad \Phi(x, y) = \frac{18}{(3g+1)^2} + 2xy = 0. \quad (44)$$

We observe that the condition $\chi_E^{(3)} = 0$ implies

$$\chi_A^{(3)} = \frac{7713280(3g-1)^2(6g-1)^2}{27(3g+1)^2} > 0, \quad \chi_B^{(3)} = -\frac{164798932(g-1)^2(3g-1)^2(6g-1)^2}{3(3g+1)^2} < 0,$$

due to (43). Therefore, the points on the hyperbola are real and distinct and the hyperbola assumes only one position.

For the above systems we calculate

$$B_2 = \frac{7776}{(3g+1)^4}(g-1)^2(2g-1)(x-y)^4 \quad (45)$$

and, by Lemma 2, for the existence of an invariant line in a direction different from $y = x$ it is necessary $B_2 = 0$.

β_1) The possibility $B_2 \neq 0$. Then $2g-1 \neq 0$ and, since $\theta \neq 0$, by Lemma 4 we could not have a couple of parallel invariant lines in the direction $y = x$ and obviously the invariant line $y = x + 6/(3g+1)$ is a simple one. As before, we consider two cases: $\mu_0 \neq 0$ and $\mu_0 = 0$.

i) The case $\mu_0 \neq 0$. Then $g(3g-2) \neq 0$ and systems (42) possess four real singularities $M_i(x_i, y_i)$ having the following coordinates:

$$\begin{aligned} x_1 &= -\frac{3}{3g+1}, \quad y_1 = \frac{3}{3g+1}; & x_3 &= -\frac{1}{3g+1}, \quad y_3 = \frac{3(2g-1)}{3g+1}; \\ x_2 &= -\frac{1}{g(3g+1)}, \quad y_2 = \frac{9g}{3g+1}; & x_4 &= -\frac{3}{(3g+1)(3g-2)}, \quad y_4 = \frac{9(2g-1)}{(3g+1)(3g-2)}. \end{aligned} \quad (46)$$

We could check directly that the singularity M_1 is a common (tangency) point of the invariant hyperbola and of line (44). Moreover, the singular point M_2 (respectively M_4) is located on the hyperbola (respectively on the invariant line), whereas the singularity M_3 is generically located outside the hyperbola as well as outside the invariant line.

For systems (22) we calculate

$$\begin{aligned} \mathbf{D} &= -\frac{64}{3(3g+1)^8}(g+1)^2(3g-5)^2(3g-1)^6, \quad \mu_0 = g(3g-2)/9, \\ \chi_C^{(3)} &= \frac{199680g(6g-1)^2}{(3g+1)^2}, \quad \chi_D^{(3)} = \frac{1472(g+1)(3g-1)^2(6g-1)}{27(3g+1)^2}. \end{aligned} \quad (47)$$

i.1) The subcase $\chi_C^{(3)} < 0$. Then $g < 0$ and the singular points $M_{1,2}$ are located on different branches of the hyperbola and we obtain the configuration *Config. H.60* if $\mathbf{D} \neq 0$ and *Config. H.69* if $\mathbf{D} = 0$.

i.2) The subcase $\chi_C^{(3)} > 0$. Then $g > 0$ and the singular points $M_{1,2}$ are located on the same branch of the hyperbola. It is clear that the reciprocal position of the singularities M_2 (located on the hyperbola) and M_4 (located on the invariant line) with respect to the tangency point M_1 of the hyperbola and the invariant line (44) defines different configurations. More exactly, the type of the configuration depends on the sign of the expression:

$$(x_1 - x_2)(x_1 - x_4) = \frac{3(3g - 1)^2}{g(3g - 2)(3g + 1)^2}.$$

Hence, we observe that $\text{sign}((x_1 - x_2)(x_1 - x_4)) = \text{sign}(\mu_0)$. So, if $\mathbf{D} \neq 0$, we arrive at the configuration *Config. H.61* if $\mu_0 < 0$ and *Config. H.59* if $\mu_0 > 0$.

We consider now the case $\mathbf{D} = 0$. Then, due to the condition (22), we have $(g + 1)(3g - 5) = 0$ and clearly the invariant polynomial $\chi_D^{(3)}$ distinguishes which one of the two factors vanishes.

If $\chi_D^{(3)} \neq 0$, then $g + 1 \neq 0$ and we get $g = 5/3$. We observe that in this case the singularity M_3 collapses with the singular point M_4 located on the invariant line. On the other hand, we calculate

$$\mathbf{T} = -256(x - y)^2(5x - y)^2(5x + y)^2/177147 < 0$$

and, by Proposition 1, we have three distinct singularities (one of them being double). Now, assuming $g = 5/3$, for systems (42), we calculate

$$\chi_C^{(3)} = 748800 > 0, \quad (x_1 - x_2)(x_1 - x_4) = 4/15 > 0$$

and hence we arrive at the configuration given by *Config. H.62*.

In the case $\chi_D^{(3)} = 0$, we have $g = -1$ and then the singularity M_3 collapses with the singular point M_2 located on the hyperbola (but outside of the invariant line). Moreover, for $g = -1$ we have

$$\mathbf{T} = -256(x - y)^2(3x + y)^2(9x + y)^2/243 < 0$$

and again we conclude that systems (42) possess three distinct singularities (one double). In this case we have

$$\chi_C^{(3)} = -2446080 < 0, \quad (x_1 - x_2)(x_1 - x_4) = 12/5 > 0$$

and therefore we get the configuration given by *Config. H.68*.

ii) The case $\mu_0 = 0$. Then $g(3g - 2) = 0$ and, by Lemma 1, at least one finite singularity has gone to infinity and coalesced with an infinite singular point. Since for systems (42) we have $\chi_C^{(3)} = 0$ if and only if $g = 0$ (see (47)), we consider two subcases: $\chi_C^{(3)} \neq 0$ and $\chi_C^{(3)} = 0$.

ii.1) The subcase $\chi_C^{(3)} \neq 0$. Then the condition $\mu_0 = 0$ implies $3g - 2 = 0$ (i.e. $g = 2/3$) and, considering the coordinates (46) of the finite singularities of systems (42), we observe that the singular point M_4 located on the invariant line has gone to infinity and collapsed with the singularity $[1, 1, 0]$. In this case calculation yields

$$\mathbf{D} = -1600/19683 < 0, \quad \chi_C^{(3)} = 133120 > 0,$$

and, since by Remark 8 the condition $\mathbf{R} \neq 0$ holds, according to Proposition 1, all three finite singularities are distinct. Moreover, due to $\chi_C^{(3)} > 0$, the singularities are located on the same branch of the hyperbola and we get the configuration given by *Config. H.57*.

ii.2) *The subcase* $\chi_C^{(3)} = 0$. Then $g = 0$ and in this case the singularity M_2 located on the hyperbola (44) has gone to infinity and collapsed with the point $[1, 0, 0]$. Since by Remark 8 we have $\mu_1 \neq 0$, according to Lemma 1 the other three finite singular points remain on the finite part of the phase plane.

Now, depending on the position of the singular point M_4 (located on the invariant line (44)) with respect to the vertical line $x = x_1$, we may get different configurations. This distinction is governed by the sign of the expression $x_4 - x_1$ and we calculate

$$\mathbf{D} = -1600/3 \neq 0, \quad x_4 - x_1 = 3/2 > 0.$$

Since by Remark 8 the condition $\mathbf{R} \neq 0$ holds, according to Proposition 1, all three finite singularities are distinct ($\mathbf{D} \neq 0$) and since $x_4 - x_1 > 0$, we arrive at the configuration given by *Config. H.50*.

β_2) *The possibility* $B_2 = 0$. Considering (45) and the condition (37), we obtain $g = 1/2$ and this leads to the system

$$\frac{dx}{dt} = -12/25 + x + x^2/2 - 2xy/3, \quad \frac{dy}{dt} = -y(1 + x/2 - y/3), \quad (48)$$

possessing the two invariant lines and the invariant hyperbola:

$$x - y + \frac{12}{5} = 0, \quad y = 0, \quad \Phi(x, y) = \frac{72}{25} + 2xy = 0.$$

as well as the following singularities $M_i(x_i, y_i)$ with the coordinates

$$x_1 = -\frac{6}{5}, y_1 = \frac{6}{5}; \quad x_3 = \frac{2}{5}, y_3 = 0; \quad x_2 = -\frac{4}{5}, y_2 = \frac{9}{5}; \quad x_4 = -\frac{12}{5}, y_4 = 0. \quad (49)$$

Hence, all singularities are located on the finite part of the phase plane since $\mu_0 = -1/36 \neq 0$. We calculate

$$\mathbf{D} = -2352/390625 < 0, \quad \chi_C^{(3)} = 319488/5 > 0.$$

Since $\chi_C^{(3)} > 0$, the singular points M_1 and M_2 are located on the same branch of the hyperbola and we need to detect the position of the singularity M_2 on the hyperbola. This fact is verified by the sign of the expression $(x_1 - x_2)(x_1 - x_4) = -12/25 < 0$. Then, we arrive at the configuration given by *Config. H.86*.

b) *The possibility* $\delta_1 = 0$. Due to condition (37) we get $a = 6(3g - 1)/(3g + 1)^2$ and we get the following 1-parameter family of systems

$$\frac{dx}{dt} = \frac{6(3g - 1)}{(3g + 1)^2} + x + gx^2 - \frac{2xy}{3}, \quad \frac{dy}{dt} = \frac{18(1 - 2g)(3g - 1)}{(3g + 1)^2} - y + (g - 1)xy + \frac{y^2}{3}, \quad (50)$$

with the conditions

$$(g - 1)(3g - 1)(3g + 1) \neq 0. \quad (51)$$

Moreover, systems (50) possess two invariant hyperbolas:

$$\Phi_1(x, y) = \frac{36(1-3g)}{(3g+1)^2} + 2xy = 0, \quad \Phi_2(x, y) = \frac{36(3g-1)}{(3g+1)^2} + \frac{12}{3g+1}x + 2x(x-y) = 0. \quad (52)$$

We observe that the family of systems (50) is a subfamily of systems (36) and hence, via the transformation (35), systems (50) could be brought to systems of the same form (50) but with the new parameter $g_1 = 2/3 - g$. So, this transformation induces a transformation in the coefficient space which fixes the point $g = 1/3$ and sends the interval $(-\infty, 1/3]$ onto the interval $[1/3, +\infty)$. Thus, in what follows we shall consider only the values of the parameter g on the interval $(-\infty, 1/3]$.

In this sense, we get the next remark.

Remark 9. *Due to an affine transformation and a time rescaling, we could assume that the parameter g in systems (50) belongs to the interval $(-\infty, 1/3]$.*

For systems (51) we calculate

$$B_1 = \frac{32}{(3g+1)^4}(g-1)^2(3g-1)^3(2g-1)(6g-1) \quad (53)$$

and we analyze two subcases: $B_1 \neq 0$ and $B_1 = 0$.

b₁) *The case $B_1 \neq 0$.* In this case due to (51) we have $(2g-1)(6g-1) \neq 0$. For systems (50) we calculate $\mu_0 = g(3g-2)/9$ and we consider two subcases: $\mu_0 \neq 0$ and $\mu_0 = 0$.

α) *The subcase $\mu_0 \neq 0$.* Then the systems have finite singularities of total multiplicity 4 with coordinates:

$$\begin{aligned} x_1 &= \frac{3g-1}{g(3g+1)}, \quad y_1 = \frac{18g}{3g+1}; & x_3 &= \frac{3(3g-1)}{(3g+1)(3g-2)}, \quad y_3 = \frac{9(2g-1)(3g-1)}{(3g+1)(3g-2)}; \\ x_2 &= -\frac{6}{3g+1}, \quad y_2 = \frac{3(1-3g)}{3g+1}; & x_4 &= -\frac{2}{3g+1}, \quad y_4 = \frac{6(1-2g)}{3g+1}. \end{aligned} \quad (54)$$

We detect that the singularities $M_{1,2}$ are located on the first invariant hyperbola (90) and moreover the singularity M_2 is also located on the second hyperbola, i.e. M_2 is a point of intersection of these two hyperbolas on the finite part of the plane. The singular point M_3 belongs to the second hyperbola, whereas the singularity M_4 generically is located outside the hyperbolas.

For systems (90) we calculate

$$\begin{aligned} \chi_F^{(3)} &= (9g-1)(9g-5)/9, \quad \mu_0 = g(3g-2)/9, \\ \mathbf{D} &= -\frac{16}{3(3g+1)^8}(9g-1)^2(9g-5)^2(5g-1)^2(15g-7)^2. \end{aligned}$$

On the other hand, we have

$$x_1x_2 = \frac{6(1-3g)}{g(3g+1)^2}, \quad \Phi_1(x_4, y_4) = \frac{12(1-5g)}{(3g-2)^2}, \quad \Phi_2(x_4, y_4) = \frac{4(15g-7)}{(3g-2)^2}.$$

We observe that the singular points $M_{1,2}$ are located on different branches (respectively on the same branch) of the first hyperbola if only if $x_1x_2 < 0$ (respectively $x_1x_2 > 0$), and this is governed

by the sign $(x_1x_2) = -\text{sign}(g(3g-1))$. Since by Remark 9 we have $g \in (-\infty, 1/3]$, we conclude that in this interval $\text{sign}(x_1x_2) = -\text{sign}(\mu_0)$.

Besides, we point out that the singular point $M_4(x_4, y_4)$ (which generically is located outside of the hyperbolas) could be located on one of these invariant hyperbolas if and only if the following condition holds:

$$[\Phi_1(M_4)][\Phi_2(M_4)] = \left[\frac{12(1-5g)}{(3g+1)^2} \right] \left[\frac{4(15g-7)}{(3g+1)^2} \right] = \frac{48(1-5g)(15g-7)}{(3g+1)^4} = 0.$$

We observe that in the case $\chi_F^{(3)} \neq 0$ the condition $(5g-1)(15g-7) = 0$ is equivalent to $\mathbf{D} = 0$.

α_1) *The possibility $\mu_0 < 0$.* According to Remark 9, the condition $\mu_0 < 0$ is equivalent to $g > 0$ and the singular points $M_{1,2}$ are located on the same branch of the first hyperbola. We calculate

$$x_1 - x_2 = \frac{9g-1}{g(3g+1)}.$$

We observe that $\text{sign}(x_1 - x_2) = \text{sign}(\chi_F^{(3)})$ due to Remark 9. Then we consider the cases $\chi_F^{(3)} < 0$, $\chi_F^{(3)} > 0$ and $\chi_F^{(3)} = 0$.

i) *The case $\chi_F^{(3)} < 0$.* Then $(9g-1)(9g-5) < 0$ and we consider two subcases: $\mathbf{D} \neq 0$ and $\mathbf{D} = 0$. If $\mathbf{D} \neq 0$ we have only simple singular points on the hyperbolas and we arrive at the configuration shown in *Config. H.128*. Otherwise, $\mathbf{D} = 0$ implies the existence of a double singular point on the first hyperbola and this point is characterized by the collision of the singular points M_1 and M_4 , and we get the configuration given by *Config. H.130*.

ii) *The case $\chi_F^{(3)} > 0$.* Then $(9g-1)(9g-5) > 0$ and we get the configuration given by *Config. H.129*.

iii) *The case $\chi_F^{(3)} = 0$.* Then $(1-5g)(9g-5) = 0$ and, according to Remark 9, we get $g = 1/5$. In this case, the singularities M_1 and M_2 have collided and we obtain a double singular point at the intersection of the two hyperbolas (90) and hence we get the configuration given by *Config. H.124*.

α_2) *The possibility $\mu_0 > 0$.* In this case the singularities $M_{1,2}$ are located on different branches of the first hyperbola and we get the configuration given by *Config. H.127*.

β) *The subcase $\mu_0 = 0$.* Then $g = 0$ and the point M_1 has coalesced with the point $[1, 0, 0]$ at infinity and we obtain the configuration shown in *Config. H.125*.

b_2) *The case $B_1 = 0$.* Considering (51), the condition $B_1 = 0$ (see (53)) is equivalent to $(2g-1)(6g-1) = 0$. According to Remark 9, we have $g = 1/6$ and in this case, besides the hyperbola, we have the invariant line $x - y + 4 = 0$. Since $B_2 = -6400(x-y)^4/9 \neq 0$, the system could not possess another invariant line by Lemma 2. Moreover, we observe that the point M_1 is the point of intersection of the first hyperbola and the invariant line. Since $\mu_0 = -1/36 < 0$ and $\chi_{13} = -7/36 < 0$, we get the configuration given by *Config. H.135*.

3.1.2.1.2 *The subcase $\beta_2 = 0$* Then $g = 1/3$ and we arrive at systems of the form

$$\frac{dx}{dt} = a + x + x^2/3 - 2xy/3, \quad \frac{dy}{dt} = b - y - 2xy/3 + y^2/3, \quad (55)$$

For systems (55) we calculate

$$\gamma_5 = 256ab(a-b)/81, \quad \mathcal{R}_4 = 128(a^2 - ab + b^2)/6561.$$

In order to have $\gamma_5 = 0$ we must have $ab(a-b) = 0$. We observe that in the case $ab = 0$ we may assume $b = 0$ due to the change $(x, y, t) \mapsto (-y, -x, -t)$. On the other hand, the systems (55) with $b = 0$ could be brought to the same systems with $b = a$ via the change $(x, y, t) \mapsto (x, x - y + 3, -t)$. Therefore, we consider the following family of systems

$$\frac{dx}{dt} = -a/3 + x + x^2/3 - 2xy/3, \quad \frac{dy}{dt} = -a/3 - y - 2xy/3 + y^2/3, \quad (56)$$

with the condition $a \neq 0$.

We observe that the above family of systems is a subfamily of systems (32) defined by the condition $h = 1/3$. For the family (32), it was shown that, due to the conditions (33) (i.e. $h \neq 1/3$), we have $\text{sign}(\chi_A^{(2)}) = \text{sign}(1 - 4ah^2)$ and $\text{sign}(\chi_B^{(2)}) = \text{sign}(x_1x_2)$. Clearly that for the subfamily (56) these invariants vanish and we need other invariant polynomials which are responsible for the sign $(1 - 4ah^2)$ and $\text{sign}(x_1x_2)$ in this particular case.

We calculate

$$(1 - 4ah^2)|_{\{h=1/3\}} = (9 - 4a)/9, \quad (x_1x_2)|_{\{h=1/3\}} = a.$$

On the other hand, for systems (56) we calculate

$$\chi_A^{(3)} = 123412480a^2(9 - 4a)/19683, \quad \chi_C^{(3)} = 1064960a^3/729$$

and hence $\text{sign}(\chi_A^{(3)}) = \text{sign}(9 - 4a)$ and $\text{sign}(\chi_C^{(3)}) = \text{sign}(x_1x_2)$.

Thus, considering the conditions and configurations for family (32), we get the configurations given by *Config. H.37* if $\chi_A^{(3)} < 0$; *Config. H.52* if $\chi_A^{(3)} > 0$ and $\chi_C^{(3)} < 0$; *Config. H.53* if $\chi_A^{(3)} > 0$ and $\chi_C^{(3)} > 0$ and *Config. H.45* if $\chi_A^{(3)} = 0$.

3.1.2.2 The case $\beta_6 = 0$. The conditions $\beta_6 = -c(g-1)(h-1)/2 = 0$ and $\theta = (g-1)(h-1)(g+h)/2 \neq 0$ imply $c = 0$. Then for systems (10) with $c = 0$ we calculate

$$\beta_7 = 2(2g-1)(2h-1)(1-2g-2h), \quad \gamma_5 = -288(g-1)(h-1)(g+h)\mathcal{B}_1\mathcal{B}_2\mathcal{B}_3,$$

where

$$\mathcal{B}_1 \equiv b(2h-1) - a(2g-1); \quad \mathcal{B}_2 \equiv b(1-2h) + 2a(g+2h-1); \quad \mathcal{B}_3 \equiv a(1-2g) + 2b(2g+h-1).$$

We consider two subcases: $\beta_7 \neq 0$ and $\beta_7 = 0$.

Remark 10. Considering systems (10) with $c = 0$, having the relation $(2h-1)(2g-1)(1-2g-2h) = 0$ (respectively $(4h-1)(4g-1)(3-4g-4h) = 0$), due to a change, we may assume any of the factors $2h-1$, $2g-1$ or $1-2g-2h$ (respectively $4h-1$, $4g-1$ or $3-4g-4h$) to be zero, for instance we could set $2h-1 = 0$ (respectively $4h-1 = 0$).

Indeed, it is sufficient to observe that in the case $2g - 1 = 0$ (respectively $4g - 1 = 0$) we could apply the change

$$(x, y, a, b, g, h) \mapsto (y, x, b, a, h, g),$$

which conserves systems (10) with $c = 0$, whereas in the case $1 - 2g - 2h = 0$ (respectively $3 - 4g - 4h = 0$) we apply the change

$$(x, y, a, b, g, h) \mapsto (y - x, -x, b - a, -a, h, 1 - g - h),$$

which also conserves systems (10) with $c = 0$.

3.1.2.2.1 The subcase $\beta_7 \neq 0$. According to Theorem 3, in this case for the existence of an invariant hyperbola, it is necessary and sufficient $\gamma_5 = 0$, which is equivalent to $\mathcal{B}_1\mathcal{B}_2\mathcal{B}_3 = 0$. We claim that, without loss of generality, we may assume $\mathcal{B}_1 = 0$, as other cases could be brought to this one via an affine transformation.

Indeed, assume first $\mathcal{B}_1 \neq 0$ and $\mathcal{B}_2 = 0$. Then we apply to systems (10) with $c = 0$ the linear transformation $x' = y - x$, $y' = -x$ and we get the systems

$$\frac{dx'}{dt} = a' + g'x'^2 + (h' - 1)x'y', \quad \frac{dy'}{dt} = b' + (g' - 1)x'y' + h'y'^2.$$

These systems have the following new parameters:

$$a' = b - a, \quad b' = -a, \quad g' = h, \quad h' = 1 - g - h.$$

A straightforward computation gives

$$\mathcal{B}'_1 = b'(2h' - 1) - a'(2g' - 1) = b(1 - 2h) + 2a(-1 + g + 2h) = \mathcal{B}_2 = 0$$

and hence, the condition $\mathcal{B}_2 = 0$ we replace by $\mathcal{B}_1 = 0$ via a linear transformation.

Analogously in the case $\mathcal{B}_1 \neq 0$ and $\mathcal{B}_3 = 0$, via the linear transformation $x'' = -y$, $y'' = x - y$, we replace the condition $\mathcal{B}_3 = 0$ by $\mathcal{B}_1 = 0$ and this completes the proof of our claim.

Since $\beta_7 \neq 0$ (i.e. $2h - 1 \neq 0$) the condition $\mathcal{B}_1 = 0$ yields $b = a(2g - 1)/(2h - 1)$ and we arrive at the 3-parameter family of systems

$$\frac{dx}{dt} = a(2h - 1) + gx^2 + (h - 1)xy, \quad \frac{dy}{dt} = a(2g - 1) + (g - 1)xy + hy^2 \quad (57)$$

with the condition

$$a(g - 1)(h - 1)(2g - 1)(2h - 1)(g + h)(2g + 2h - 1) \neq 0. \quad (58)$$

These systems possess the invariant hyperbola

$$\Phi(x, y) = a + xy = 0. \quad (59)$$

For systems (57) we calculate

$$\begin{aligned} \beta_8 &= 2(4g - 1)(4h - 1)(3 - 4g - 4h), \\ \delta_2 &= 2a(4g - 1)(4h - 1)[68(g^2 + h^2) + 236gh - 79(g + h) - 144gh(g + h) + 22], \end{aligned} \quad (60)$$

According to Theorem 3, these systems possess either one or two invariant hyperbolas if either $\beta_8^2 + \delta_2^2 \neq 0$ or $\beta_8 = \delta_2 = 0$, respectively.

We claim that the condition $\beta_8 = \delta_2 = 0$ is equivalent to $(4g - 1)(4h - 1) = 0$. Indeed, assuming that $(4g - 1)(4h - 1) \neq 0$ and $\beta_8 = \delta_2 = 0$ we obtain

$$3 - 4g - 4h = 0, \quad 68(g^2 + h^2) + 236gh - 79(g + h) - 144gh(g + h) + 22 = 0.$$

The first equation gives $g = 3/4 - h$ and then from the second one we obtain $(2h - 1)(4h - 1) = 0$, which contradicts the condition (58) and the assumption. This completes the proof of our claim.

a) *The possibility $\beta_8^2 + \delta_2^2 \neq 0$.* Then this implies $(4g - 1)(4h - 1) \neq 0$ and systems (57) possess only one invariant hyperbola. For these systems we calculate

$$B_1 = 2a^3(g - 1)^2(h - 1)^2(2g - 1)(2h - 1)(g - h)(g + h)^2$$

and considering (58) we conclude that the condition $B_1 = 0$ is equivalent to $g - h = 0$. We examine two cases: $B_1 \neq 0$ and $B_1 = 0$.

α_1) *The case $B_1 \neq 0$.* Then $g - h \neq 0$ and by Lemma 2 we have no invariant lines. For systems (57) we calculate $\mu_0 = gh(g + h - 1)$ and we consider two subcases: $\mu_0 \neq 0$ and $\mu_0 = 0$.

α) *The subcase $\mu_0 \neq 0$.* In this case the systems have finite singularities of total multiplicity 4 with the following coordinates $M_i(x_i, y_i)$:

$$\begin{aligned} x_{1,2} &= \pm \frac{\sqrt{-agh}}{g}, & y_{1,2} &= \pm \frac{\sqrt{-agh}}{h}, \\ x_{3,4} &= \pm(2h - 1) \frac{\sqrt{a(1 - g - h)}}{g + h - 1}, & y_{3,4} &= \pm(2g - 1) \frac{\sqrt{a(1 - g - h)}}{g + h - 1}. \end{aligned}$$

We detect that the singularities $M_{1,2}$ are located on the invariant hyperbola. More exactly, these singular points are located on different branches (respectively on the same branch) of the hyperbola if only if $x_1x_2 < 0$ (respectively $x_1x_2 > 0$), where $x_1x_2 = ah/g$. Moreover, these singularities are real if $agh < 0$, they are complex if $agh > 0$ and they coincide if $agh = 0$.

On the other hand, we calculate

$$\begin{aligned} \chi_A^{(4)} &= -16128 a^5 gh(g - 1)^2(h - 1)^2(g + h)^4(2g - 1)^4(2h - 1)^4(4g - 1)^2(4h - 1)^2, \\ \chi_B^{(4)} &= -4257792 a^5 (g + h)^4(2g - 1)^6(2h - 1)^6(4g - 1)^2(4h - 1)^2 \end{aligned}$$

and due to the condition (58) we have $\text{sign}(\chi_A^{(4)}) = -\text{sign}(agh) = -\text{sign}(x_1x_2)$ and $\text{sign}(\chi_B^{(4)}) = -\text{sign}(a)$ (which corresponds to the position of the hyperbola). We observe that in the case the singular points M_1 and M_2 are real, they must be located on different branches of the hyperbola (we recall that systems (57) is symmetric with respect to the origin). Moreover, we could not have $\chi_A^{(4)} = 0$ due to $\mu_0 \neq 0$ and (58).

Besides, we point out that at least one of the singular points $M_{3,4}$ could be located on the invariant hyperbola and we determine the conditions for this to happen. We calculate

$$\Phi(x_3, y_3) = \Phi(x_4, y_4) = \frac{a(4gh - g - h)}{g + h - 1}.$$

It is clear that both of the singular points M_3 and M_4 belong to the hyperbola (141) if and only if $4gh - g - h = 0$. Since

$$\mathbf{D} = -768a^4(4gh - g - h)^4\mu_0,$$

we deduce that both of the singular points $M_{3,4}$ belong to the hyperbola if and only if $\mathbf{D} = 0$.

α_1) The possibility $\chi_A^{(4)} < 0$. So we have no real singularities located on the invariant hyperbolas and we arrive at the configurations given by *Config. H.1* if $\chi_B^{(4)} < 0$ and *Config. H.2* if $\chi_B^{(4)} > 0$.

α_2) The possibility $\chi_A^{(4)} > 0$. In this case we have two real singularities located on the hyperbola and they are located on different branches. Now, we need to decide if both of the singular points $M_{3,4}$ will belong to the hyperbola.

i) The case $\mathbf{D} \neq 0$. Then $4gh - g - h \neq 0$ and on the hyperbola there are two simple real singularities and we obtain the configurations given by *Config. H.17* if $\chi_B^{(4)} < 0$ and *Config. H.19* if $\chi_B^{(4)} > 0$.

ii) The case $\mathbf{D} = 0$. Then $4gh - g - h = 0$ (i.e. $g = h/(4h - 1)$) and in this case we calculate

$$\begin{aligned}\chi_A^{(4)} &= -4128768 a^5 h^{10} (h - 1)^2 (2h - 1)^8 (3h - 1h)^2 / (4h - 1)^{11}, \\ \mathbf{D} = \mathbf{T} = 0, \quad \mathbf{PR} &= -256a^3 h^8 (2h - 1)^8 [x - (4h - 1)y]^6 / (4h - 1)^{11}\end{aligned}$$

and, due to $\chi_A^{(4)} > 0$, we have $\mathbf{PR} > 0$ and on the hyperbola there are two double real singularities (see Proposition 1) we arrive at the configurations given by *Config. H.27* if $\chi_B^{(4)} < 0$ and *Config. H.28* if $\chi_B^{(4)} > 0$.

β) The subcase $\mu_0 = 0$. We consider the possibilities: $\chi_A^{(4)} < 0$, $\chi_A^{(4)} > 0$ and $\chi_A^{(4)} = 0$.

β_1) The possibility $\chi_A^{(4)} < 0$. Then $gh \neq 0$ and the condition $\mu_0 = 0$ yields $g = 1 - h$. So we calculate

$$\mathbf{D} = 0, \quad \mu_1 = 0, \quad \mu_2 = ah(1 - h)(2h - 1)^2(x - y)^2 \neq 0.$$

Hence, two singular points go to infinity in the direction $y = x$ and we get the configurations *Config. H.5* if $\chi_B^{(4)} < 0$ and *Config. H.6* if $\chi_B^{(4)} > 0$.

β_2) The possibility $\chi_A^{(4)} > 0$. As in the previous subcase, two singular points go to infinity in the direction $y = x$ and, moreover, the singularities $M_{1,2}$ are real. So we obtain the configurations *Config. H.35* if $\chi_B^{(4)} < 0$ and *Config. H.36* if $\chi_B^{(4)} > 0$.

α_2) The case $B_1 = 0$. Then by conditions (58), we get $g = h$ and systems (57) possess the invariant line $x - y = 0$. For this case due to (58) we have

$$\mu_0 = h^2(2h - 1) \neq 0, \quad \mathbf{D} = 12288a^4 h^6 (1 - 2h)^5 \neq 0.$$

α) The subcase $\chi_A^{(4)} < 0$. In this case the singularities $M_{1,2}$ are complex and, since

$$\chi_A^{(4)} = -258048 a^5 h^6 (h - 1)^4 (2h - 1)^8 (4h - 1)^4 < 0,$$

we have $\chi_B^{(4)} = -68124672 a^5 h^4 (2h - 1)^{12} (4h - 1)^4 < 0$. So, we obtain the unique configuration *Config. H.37*.

β) The subcase $\chi_A^{(4)} > 0$. In this case the singularities $M_{1,2}$ are real and analogously we have $\text{sign}(\chi_A^{(4)}) = \text{sign}(\chi_B^{(4)})$. So we get the unique configuration *Config. H.53*.

b) The possibility $\beta_8 = \delta_2 = 0$. Then this implies $(4g - 1)(4h - 1) = 0$ and, due to a change, we may assume $h = 1/4$, without loss of generality. In this case, systems (57) possess the two invariant hyperbolas

$$\Phi_1(x, y) = a + xy = 0, \quad \Phi_2(x, y) = a - x(x - y) = 0.$$

For these systems we calculate

$$\mu_0 = g(4g - 3)/16, \quad B_1 = 9a^3(g - 1)^2(2g - 1)(4g - 1)(4g + 1)^2/1024$$

and, due to conditions (58), we verify that $B_1 \neq 0$. Then we consider two cases $\mu_0 \neq 0$ and $\mu_0 = 0$.

b₁) The case $\mu_0 \neq 0$. Then $g(4g - 3) \neq 0$ and the systems have finite singularities of total multiplicity 4 with the following coordinates $M_i(x_i, y_i)$:

$$x_{1,2} = \pm \frac{\sqrt{-ag}}{2g}, \quad y_{1,2} = \pm 2\sqrt{-ag}, \quad x_{3,4} = \pm \frac{\sqrt{-a(4g - 3)}}{4g - 3}, \quad y_{3,4} = \pm 2(2g - 1) \frac{\sqrt{-a(4g - 3)}}{4g - 3}.$$

We detect that the singularities $M_{1,2}$ are located on the invariant hyperbola $\Phi_1(x, y) = 0$. More exactly, these singular points are located on different branches (respectively on the same branch) of the hyperbola if only if $x_1x_2 < 0$ (respectively $x_1x_2 > 0$), where $x_1x_2 = a/4g$. Moreover, these singularities are real if $ag < 0$, they are complex if $ag > 0$ and they coincide if $ag = 0$. We also point out that the position of the hyperbolas are governed by $\text{sign}(a)$.

On the other hand, we calculate

$$\chi_A^{(5)} = -41 a(8g - 3)^3/128.$$

We observe that in the case the singular points M_1 and M_2 are real, they must be located on different branches of the hyperbola (we recall that systems (57) is symmetric with respect to the origin). Moreover, we could not have $\chi_A^{(5)} = 0$ due to $\mu_0 \neq 0$ and (58).

Moreover, we also detect that the singularities $M_{3,4}$ are located on the invariant hyperbola $\Phi_2(x, y) = 0$ and their position concerning which branch they are located is also governed by $\text{sign}(a)$ and they will be complex, real or coinciding depending on the sign of the expression $a(4g - 3)$ and hence the sign of μ_0 plays an important role in this analysis.

Besides, we point out that the singular points $M_{1,2}$ could not be located on the hyperbola $\Phi_2(x, y) = 0$ and, conversely, $M_{3,4}$ could not be located on the hyperbola $\Phi_1(x, y) = 0$, since we have

$$\Phi_2(x_{1,2}, y_{1,2}) = \frac{a}{4g} \neq 0, \quad \Phi_1(x_{3,4}, y_{3,4}) = \frac{a}{3 - 4g} \neq 0,$$

due to conditions (58).

We consider the case $\mu_0 < 0$ (i.e. $0 < g < 3/4$). Then, for these values of g , we have $8g - 3 < 0$ and, independently of the sign of a , we get the unique configuration *Config. H.123*.

In the case $\mu_0 > 0$, we obtain the configuration *Config. H.121* if $\chi_A^{(5)} < 0$ and *Config. H.131* if $\chi_A^{(5)} > 0$.

b₂) *The case $\mu_0 = 0$.* Then $g(4g - 3) = 0$ and depending on which one of these two factors vanishes, we have different finite singular points coalescing with an infinite singular point. More precisely, if $4g - 3 = 0$ then the singular points $M_{3,4}$ coalesce with $[1, 1, 0]$, and if $g = 0$ then the singular points $M_{1,2}$ coalesce with $[1, 0, 0]$.

However, we observe that, applying the change $(x, y, t, a) \mapsto (-x, y - x, t, -a)$, we could bring systems (58) with $h = 1/4$ and $g = 3/4$ to the same systems with $h = 1/4$ and $g = 0$. So, without loss of generality, we may assume $g = 0$.

Thus, we obtain the configurations given by *Config. H.122* if $\chi_A^{(5)} < 0$ and *Config. H.126* if $\chi_A^{(5)} > 0$.

3.1.2.2.2 The subcase $\beta_7 = 0$. We recall that the conditions $\beta_1 = \beta_6 = 0$ yields $c = 0$ and systems (10) with $c = 0$ becomes

$$\frac{dx}{dt} = a + gx^2 + (h - 1)xy, \quad \frac{dy}{dt} = b + (g - 1)xy + hy^2. \quad (61)$$

Without loss of generality, Remark 10 assures us that we may choose $g = 1/2 - h$ in order to have $\beta_7 = 2(2g - 1)(2h - 1)(1 - 2g - 2h) = 0$.

Now, we calculate

$$\beta_9 = 4h(1 - 2h)$$

and we analyze two possibilities: $\beta_9 \neq 0$ and $\beta_9 = 0$.

a) *The possibility $\beta_9 \neq 0$.* As earlier, according to Theorem 3, in this case for the existence of at least one invariant hyperbola, it is necessary and sufficient $\gamma_5 = 0$, which is equivalent to $\mathcal{B}_1\mathcal{B}_2\mathcal{B}_3 = 0$ and, without loss of generality, we may assume $\mathcal{B}_1 = 0$, as other cases could be brought to this one via an affine transformation.

a₁) *The case $\delta_3 \neq 0$.* In this case we have only one invariant hyperbola and the condition $\delta_3 \neq 0$ yields $a - b \neq 0$. Then, the condition $\gamma_5 = 0$ is equivalent to $b(1 - 2h) - 2ah = 0$, which could be rewritten as $a = a_1(2h - 1)$ and $b = -2a_1h$. So, setting the old parameter a instead of a_1 , we arrive at the 2-parameter family of systems

$$\frac{dx}{dt} = a(2h - 1) + (1 - 2h)x^2/2 + (h - 1)xy, \quad \frac{dy}{dt} = -2ah - (2h + 1)xy/2 + hy^2, \quad (62)$$

with the condition

$$ah(h - 1)(2h - 1)(2h + 1)(4h - 1) \neq 0. \quad (63)$$

These systems possess the invariant hyperbola

$$\Phi(x, y) = a + xy = 0. \quad (64)$$

We observe that, due to (63),

$$B_1 = a^3h(h - 1)^2(2h - 1)(2h + 1)^2(4h - 1) \neq 0$$

and, hence, systems (62) possess no invariant line. Moreover, we have

$$\mu_0 = h(2h - 1)/4 \neq 0, \quad \mathbf{D} = 12a^4h(1 - 2h)(1 - 4h + 8h^2)^4 \neq 0,$$

due to the same conditions, and then all the finite singularities are in the finite part of the phase plane and none of them coalesces with other points. Considering the coordinates of these singularities $M_i(x_i, y_i)$ ($i=1,2,3,4$), we have

$$x_{1,2} = \pm \frac{\sqrt{2ah(2h-1)}}{2h-1}, \quad y_{1,2} = \mp \frac{\sqrt{2ah(2h-1)}}{2h}, \quad x_{3,4} = \pm(2h-1)\sqrt{2a}, \quad y_{3,4} = \pm 2h\sqrt{2a}.$$

After simple calculations, we obtain that $M_{1,2}$ are located on the hyperbola, whereas $M_{3,4}$ are located generically outside the hyperbola. Then, the singular points $M_{1,2}$ are complex if $ah(2h-1) < 0$ and they are real if $ah(2h-1) > 0$. We point out that these two singularities could not coincide since $ah(2h-1) \neq 0$, due to (63). So, we need to control sign ($ah(2h-1)$). Moreover, sign (a) gives the position of the hyperbola on the phase plane.

On the other hand, we calculate

$$\begin{aligned} \chi_A^{(4)} &= 2016 a^5 h^5 (h-1)^2 (2h-1)^5 (2h+1)^2 (4h-1)^4, \\ \chi_B^{(4)} &= -17031168 a^5 h^6 (2h-1)^6 (4h-1)^4. \end{aligned}$$

Therefore, we arrive at the following conditions and configurations:

- $\chi_A^{(4)} < 0$ and $\chi_B^{(4)} < 0 \Rightarrow$ *Config. H.1*;
- $\chi_A^{(4)} < 0$ and $\chi_B^{(4)} > 0 \Rightarrow$ *Config. H.2*;
- $\chi_A^{(4)} > 0$ and $\chi_B^{(4)} < 0 \Rightarrow$ *Config. H.17*;
- $\chi_A^{(4)} > 0$ and $\chi_B^{(4)} > 0 \Rightarrow$ *Config. H.19*.

a₂) *The case $\delta_3 = 0$.* In this case, the conditions $\gamma_5 = \delta_3 = 0$ yield $a - b = 0$ (i.e. $b = a$) and systems

$$\frac{dx}{dt} = a + (1-2h)x^2/2 + (h-1)xy, \quad \frac{dy}{dt} = a - (2h+1)xy/2 + hy^2, \quad (65)$$

with the condition

$$ah(h-1)(2h-1)(2h+1) \neq 0, \quad (66)$$

possess at least two invariant hyperbolas. We calculate $\beta_8 = -2(4h-1)^2$ and we analyze two subcases: $\beta_8 \neq 0$ and $\beta_8 = 0$.

α) *The subcase $\beta_8 \neq 0$.* Then $4h-1 \neq 0$ and systems (65) possess two invariant hyperbolas:

$$\Phi_1(x, y) = -\frac{a}{2h-1} + x(x-y) = 0, \quad \Phi_2(x, y) = \frac{a}{h} + 2y(x-y) = 0. \quad (67)$$

We observe that

$$B_1 = 0, \quad B_2 = -162a^2(h-1)^2(2h+1)^2(x-y)^4 \neq 0,$$

due to (66), and this implies that systems (65) possess only one invariant straight line, namely $x - y = 0$.

Due to condition (66), we obtain

$$\mu_0 = h(2h - 1)/4 \neq 0, \quad \mathbf{D} = -12a^4h(2h - 1) \neq 0,$$

and then we have four distinct finite singularities $M_i(x_i, y_i)$ ($i=1,2,3,4$), where

$$x_{1,2} = \pm \frac{\sqrt{2ah(2h-1)}}{2h-1}, \quad y_{1,2} = \pm \frac{\sqrt{2ah(2h-1)}}{2h}, \quad x_{3,4} = \pm\sqrt{2a}, \quad y_{3,4} = \pm\sqrt{2a}.$$

We observe that the singular points $M_{1,2}$ are located on the first hyperbola (67), whereas $M_{3,4}$ are located on the invariant line. Additionally, the singularities $M_{1,2}$ (respectively $M_{3,4}$) are complex if $ah(2h-1) < 0$ (respectively $a < 0$) and are real if $ah(2h-1) > 0$ (respectively $a > 0$).

So, we need to control sign $(ah(2h-1))$ and sign (a) . Moreover, sign $(h(2h-1))$ gives the position of the hyperbolas on the phase plane.

On the other hand, we calculate

$$\chi_A^{(6)} = ah(2h-1).$$

If $\chi_A^{(6)} < 0$, then the singularities $M_{1,2}$ are complex and we get the configuration *Config. H.132* if $\mathbf{D} < 0$ and *Config. H.133* if $\mathbf{D} > 0$.

In the case $\chi_A^{(6)} > 0$, the singular points $M_{1,2}$ are real and we obtain the configuration *Config. H.136* if $\mathbf{D} < 0$ and *Config. H.134* if $\mathbf{D} > 0$.

β) *The subcase $\beta_8 = 0$.* Then $h = 1/4$ and systems (65) possess three invariant hyperbolas, namely the two presented in (67) with $h = 1/4$ and

$$\Phi_3(x, y) = 2a - xy = 0.$$

In this case, we observe that $\mathbf{D} = 3a^4/2 > 0$ and we obtain the configuration *Config. H.156* if $\chi_A^{(6)} < 0$ and *Config. H.157* if $\chi_A^{(6)} > 0$.

b) *The possibility $\beta_9 = 0$.* Then $h = 0$ (this yields $g = 1/2$) and systems (61) becomes

$$\frac{dx}{dt} = a + x^2/2 - xy, \quad \frac{dy}{dt} = b - xy/2. \quad (68)$$

According to Theorem 3, in this case for the existence of at least one invariant hyperbola, it is necessary and sufficient $\gamma_6 = 0$, which is equivalent to $(a-b)b = 0$. Without loss of generality, we may assume $b = 0$, since we could pass from the case $b = a$ to the case $b = 0$, via the affine transformation $(x, y, t) \mapsto (x, x-y, -t)$. Then, we arrive at the 1-parameter family of systems

$$\frac{dx}{dt} = a + x^2/2 - xy, \quad \frac{dy}{dt} = -xy/2. \quad (69)$$

with the condition $a \neq 0$.

The above family possesses the invariant hyperbola

$$\Phi(x, y) = a - xy = 0 \quad (70)$$

and, since $B_1 = 0$ and $B_2 = -162a^2y^4 \neq 0$, due to $a \neq 0$, systems (69) possess the only one invariant line $y = 0$.

We calculate

$$\mu_0 = \mu_1 = 0, \quad \mu_2 = ax^2/8, \quad \mathbf{D} = 0.$$

Then, two finite singular points has collapsed and gone to infinity and coalesced with $[0, 1, 0]$. Considering the remaining singularities on the finite part of the plane, their coordinates are $M_i(x_i, y_i)$ ($i = 1, 2$):

$$x_{1,2} = \pm\sqrt{-2a}, \quad y_{1,2} = 0.$$

We point out that these two singularities are located on the invariant line and they are complex if $a > 0$ and are real if $a < 0$. So, we need to control sign (a), which also gives the position of the hyperbola on the phase plane.

On the other hand, we calculate

$$\chi_A^{(5)} = -a/16.$$

So, we obtain the configuration *Config. H.40* if $\chi_A^{(5)} < 0$ and *Config. H.58* if $\chi_A^{(5)} > 0$.

3.2 The subcase $\theta = 0$

For systems (3) we assume $\eta > 0$ and therefore we consider systems (9) for which we have

$$\theta = -(g-1)(h-1)(g+h)/2.$$

Since $\theta = 0$, we get $(g-1)(h-1)(g+h) = 0$ and we may assume $g = -h$, otherwise in the case $g = 1$ (respectively $h = 1$) we apply the change $(x, y, g, h) \mapsto (-y, x-y, 1-g-h, g)$ (respectively $(x, y, g, h) \mapsto (y-x, -x, h, 1-g-h)$) which preserves the quadratic parts of systems (9).

So, $g = -h$ and we arrive at the systems

$$\frac{dx}{dt} = a + cx - hx^2 + (h-1)xy, \quad \frac{dy}{dt} = b + fy + (h+1)xy + hy^2, \quad (71)$$

for which we calculate $N = 9(h^2 - 1)(x - y)^2$. We consider two possibilities: $N \neq 0$ and $N = 0$.

3.2.1 The possibility $N \neq 0$

For systems (71), we calculate

$$\begin{aligned} \gamma_1 &= (c-f)^2(c+f)(h-1)^2(h+1)^2(3h-1)(3h+1)/64, \\ \beta_6 &= (c-f)(h-1)(h+1)/4, \quad \beta_{10} = -2(3h-1)(3h+1). \end{aligned}$$

According to Theorem 3, a necessary condition for the existence of hyperbolas for these systems is $\gamma_1 = 0$.

3.2.1.1 *The case $\beta_6 \neq 0$.* Then $c-f \neq 0$ and the condition $\gamma_1 = 0$ yields $(c+f)(3h-1)(3h+1) = 0$. So, we consider the subcases: $\beta_{10} \neq 0$ and $\beta_{10} = 0$.

3.2.1.1.1 *The subcase $\beta_{10} \neq 0$.* Then $(3h - 1)(3h + 1) \neq 0$ and we get $f = -c$ and obtain the following systems

$$\frac{dx}{dt} = a + cx - hx^2 + (h - 1)xy, \quad \frac{dy}{dt} = b - cy - (h + 1)xy + hy^2. \quad (72)$$

Now, in order to possess at least one hyperbola, it is necessary and sufficient that for the above systems the condition

$$\gamma_7 = 8(h - 1)(h + 1)[a(2h + 1) + b(2h - 1)] = 0$$

holds, and due to $N \neq 0$ this is equivalent to $a(2h + 1) + b(2h - 1) = 0$.

Since $\beta_6 = c(h - 1)(h + 1)/2 \neq 0$ (i.e. $c \neq 0$), we could apply the rescaling $(x, y, t) \mapsto (cx, cy, t/c)$ and assume $c = 1$. Moreover, since $(2h - 1)^2 + (2h + 1)^2 \neq 0$, the condition $a(2h + 1) + b(2h - 1) = 0$ could be written as $a = -a_1(2h - 1)$ and $b = a_1(2h + 1)$. So, setting the old parameter a instead of a_1 , we arrive at the 2-parameter family of systems

$$\frac{dx}{dt} = a(2h - 1) + x - hx^2 + (h - 1)xy, \quad \frac{dy}{dt} = -a(2h + 1) - y - (h + 1)xy + hy^2, \quad (73)$$

with the conditions

$$a(h - 1)(h + 1)(3h - 1)(3h + 1) \neq 0. \quad (74)$$

We observe that the family of systems (73) is a subfamily of systems (12) with $g = -h$.

The above systems possess the invariant hyperbola

$$\Phi(x, y) = a + xy = 0 \quad (75)$$

and for them we calculate

$$B_1 = -4a^2h(h - 1)^2(h + 1)^2(2h - 1)(2h + 1). \quad (76)$$

a) *The possibility $B_1 \neq 0$.* Then $h(2h - 1)(2h + 1) \neq 0$ and by Lemma 2 systems (73) possess no invariant lines. Since $\mu_0 = h^2 \neq 0$, these systems have finite singularities $M_i(x_i, y_i)$ of total multiplicity 4, whose coordinates are

$$x_{1,2} = \frac{1 \pm \sqrt{1 + 4ah^2}}{2h}, \quad y_{1,2} = \frac{1 \mp \sqrt{1 + 4ah^2}}{2h},$$

$$x_{3,4} = \frac{(2h - 1)(1 \pm \sqrt{1 + 4a})}{2}, \quad y_{3,4} = \frac{(2h + 1)(1 \pm \sqrt{1 + 4a})}{2}.$$

We observe that the singular points $M_{1,2}$ are located on the hyperbola, whereas the singularities $M_{3,4}$ are generically located outside of it.

On the other hand, for systems (73), we calculate the invariant polynomials

$$\chi_A^{(1)} = h^2(h - 1)^2(h + 1)^2(3h - 1)^2(3h + 1)^2(1 + 4ah^2)/16,$$

$$\chi_B^{(1)} = -105ah^2(h - 1)^2(h + 1)^2(3h - 1)^2(3h + 1)^2/2$$

and, by the condition (74), we conclude that $\text{sign}(\chi_A^{(1)}) = \text{sign}(1 + 4ah^2)$ (if $1 + 4ah^2 \neq 0$) and $\text{sign}(\chi_B^{(1)}) = -\text{sign}(a)$. So, we consider three cases: $\chi_A^{(1)} < 0$, $\chi_A^{(1)} > 0$ and $\chi_A^{(1)} = 0$.

a₁) The case $\chi_A^{(1)} < 0$. Then $1 + 4ah^2 < 0$ yields $a < 0$ and hence $\chi_B^{(1)} > 0$. So, since the singular points located on the hyperbola are complex, we arrive at the configuration given by *Config. H.2*.

a₂) The case $\chi_A^{(1)} > 0$. In this case, we have two real singularities located on the hyperbola. We calculate $x_1x_2 = -a$ and, due to the condition (74), we obtain that $\text{sign}(\chi_B^{(1)}) = \text{sign}(x_1x_2)$, which defines the location of the singular points $M_{1,2}$ concerning the branches of the hyperbola (i.e. they are located either on different branches if $\chi_B^{(1)} < 0$ or on the same branch if $\chi_B^{(1)} > 0$).

However, we need to detect when the singularities $M_{3,4}$ also belong to the hyperbola. In this order, considering (75), we calculate

$$\Phi(x, y)|_{\{x=x_{3,4}, y=y_{3,4}\}} = \frac{4h^2[1 + 2a \mp \sqrt{1 + 4a}] - 1 \pm \sqrt{1 + 4a}}{2} \equiv \Omega_{3,4}(a, g, h).$$

It is clear that at least one of the singular points M_3 or M_4 belongs to the hyperbola (75) if and only if

$$\Omega_3\Omega_4 = a(16ah^4 + 4h^2 - 1) = 0.$$

On the other hand, for systems (73), we have

$$\chi_D^{(1)} = -105h(3h - 1)(3h + 1)(16ah^4 + 4h^2 - 1)$$

and clearly, due to (74), the condition $\chi_D^{(1)} = 0$ is equivalent to $16ah^4 + 4h^2 - 1 = 0$. We examine two subcases: $\chi_D^{(1)} \neq 0$ and $\chi_D^{(1)} = 0$.

α) The subcase $\chi_D^{(1)} \neq 0$. Then, on the hyperbola there only two simple real singularities and we obtain the configurations given by *Config. H.17* if $\chi_B^{(1)} < 0$ and *Config. H.18* if $\chi_B^{(1)} > 0$.

β) The subcase $\chi_D^{(1)} = 0$. In this case, the condition $16ah^4 + 4h^2 - 1 = 0$ yields $a = -(2h - 1)(2h + 1)/(16h^4)$ and we calculate

$$\mathbf{D} = 0, \quad \mathbf{T} = -3(2h^2 - 1)^2(x + y)^2[(2h + 1)x - (2h - 1)y]^2[(h + 1)(2h + 1)x - (h - 1)(2h - 1)y]^2.$$

If $\mathbf{T} \neq 0$, then we have a double and a simple singular points on the hyperbola and we arrive at the configurations shown in *Config. H.21* if $\chi_B^{(1)} < 0$ and *Config. H.22* if $\chi_B^{(1)} > 0$. In the case $\mathbf{T} = 0$, we obtain $h = \pm\sqrt{2}/2$ and hence $\chi_B^{(1)} > 0$. Then, we have a triple and a simple singular points on the hyperbola and we obtain the configuration *Config. H.25*.

a₃) The case $\chi_A^{(1)} = 0$. Then $a = -1/(4h^2)$ and hence $\chi_B^{(1)} > 0$. In this case, the singular points M_1 and M_2 coalesce and we get the configuration *Config. H.8*.

b) The possibility $B_1 = 0$. Then $h(2h - 1)(2h + 1) = 0$ and we analyze the two cases: $\mu_0 \neq 0$ and $\mu_0 = 0$.

b₁) The case $\mu_0 \neq 0$. Then $h \neq 0$ and the condition $B_1 = 0$ is equivalent to $(2h - 1)(2h + 1) = 0$. Without loss of generality, we may assume $h = -1/2$, otherwise we apply the change $(x, y, t, h) \mapsto (-y, -x, -t, a, -h)$, which keeps systems (73) and changes the sign of h .

So $h = 1/2$ and then systems (73) possess the invariant line $y = 0$ and the singularities $M_{3,4}$ are located on this line. In this case, we calculate

$$\chi_A^{(1)} = 225(a + 1)/16384, \quad \chi_B^{(1)} = -23625a/2048, \quad \mathbf{D} = -48a^2(a + 1)(4a + 1).$$

α) The subcase $\chi_A^{(1)} < 0$. Then $a + 1 < 0$ implies $a < 0$ and hence $\chi_B^{(1)} > 0$. So, we obtain the configuration shown in *Config. H.38*.

β) The subcase $\chi_A^{(1)} > 0$. Then $a > -1$ and we have real singularities on the hyperbola. So, we get the following conditions and configurations:

- $\chi_B^{(1)} < 0 \Rightarrow$ *Config. H.75*;
- $\chi_B^{(1)} > 0$ and $\mathbf{D} < 0 \Rightarrow$ *Config. H.72*;
- $\chi_B^{(1)} > 0$ and $\mathbf{D} > 0 \Rightarrow$ *Config. H.46*;
- $\chi_B^{(1)} > 0$ and $\mathbf{D} = 0 \Rightarrow$ *Config. H.65*.

γ) The subcase $\chi_A^{(1)} = 0$. Then $a = -1$ (consequently $\mathbf{D} = 0$ and $\chi_B^{(1)} > 0$) and this implies the existence of a double singular point on the hyperbola and the singularities on the invariant line are complex, obtaining the configuration *Config. H.42*.

b_2) The case $\mu_0 = 0$. Then $h = 0$ and we also have $\mu_1 = 0$ and $\mu_2 = -xy$, which means that the singular points $M_{1,2}$ have gone to infinity and coalesced with the singular points $[1, 0, 0]$ and $[0, 1, 0]$.

Considering Lemma 3 we detect that Z is a simple factor of \mathcal{E}_1 and \mathcal{E}_2 . So, we deduce that the infinity line $Z = 0$ is a double invariant line for systems (73). Since $\chi_A^{(1)} = 1 > 0$, we obtain the configurations *Config. H.76* if $\chi_B^{(1)} < 0$ and *Config. H.77* if $\chi_B^{(1)} > 0$.

3.2.1.1.2 The subcase $\beta_{10} = 0$. Then $(3h - 1)(3h + 1) = 0$ and as earlier we may assume $h = 1/3$ and obtain the following systems

$$\frac{dx}{dt} = -\frac{a}{3} + x - \frac{x^2}{3} - \frac{2xy}{3}, \quad \frac{dy}{dt} = -\frac{5a}{3} - y - \frac{4xy}{3} + \frac{y^2}{3}, \quad (77)$$

with the condition $a \neq 0$. We again remark that the family of systems (77) is a subfamily of systems (12) with $g = -h$ and $h = 1/3$.

These systems possess the invariant hyperbola

$$\Phi(x, y) = a + xy = 0. \quad (78)$$

and for them we calculate

$$\mu_0 = 1/9, \quad \mathbf{D} = -16(4a + 1)(4a + 9)(16a - 45)/19683, \quad B_1 = 1280a^2/2187.$$

Since $B_1 \neq 0$, systems (77) do not possess invariant lines and the condition $\mu_0 \neq 0$ implies that the finite singularities $M_i(x_i, y_i)$ are of total multiplicity 4, and their coordinates are

$$x_{1,2} = \frac{3 \pm \sqrt{4a + 9}}{2}, \quad y_{1,2} = \frac{3 \mp \sqrt{4a + 9}}{2}, \quad x_{3,4} = \frac{-1 \pm \sqrt{4a + 1}}{6}, \quad y_{3,4} = \frac{5(1 \mp \sqrt{4a + 1})}{6}.$$

We observe that the singular points $M_{1,2}$ are located on the hyperbola, whereas the singularities $M_{3,4}$ are generically located outside of it.

Concerning the singular points $M_{1,2}$, we see that $x_1x_2 = -a$ and the sign (a) will detect the location of these singularities on the same or different branches of the hyperbola as well as its position on the phase plane.

Moreover, we need to detect when the singularities $M_{3,4}$ also belong to the hyperbola. Considering (78), we calculate

$$\Phi(x, y)|_{\{x=x_{3,4}, y=y_{3,4}\}} = \frac{8a \pm 5\sqrt{4a+1} - 5}{18} \equiv \Omega'_{3,4}(a, g, h)$$

and we observe that at least one of the singular points M_3 or M_4 belongs to the hyperbola (78) if and only if

$$\Omega'_3\Omega'_4 = \frac{a(16a - 45)}{18} = 0.$$

On the other hand, for systems (77), we calculate the invariant polynomials

$$\begin{aligned} \chi_A^{(3)} &= \frac{123412480(4a+9)}{243}, & \chi_B^{(3)} &= -\frac{168754106368a}{243}, \\ \chi_C^{(3)} &= -\frac{1064960a}{9}, & \chi_D^{(3)} &= \frac{5888(16a-45)}{729} \end{aligned}$$

and we conclude that $\text{sign}(\chi_A^{(3)}) = \text{sign}(4a+9)$ (if $4a+9 \neq 0$), $\text{sign}(\chi_B^{(3)}) = \text{sign}(\chi_C^{(3)}) = -\text{sign}(a)$ and at least one of the singular points M_3 or M_4 belongs to the hyperbola if and only if $\chi_D^{(3)} = 0$.

We observe that the condition $\chi_A^{(3)} < 0$ implies $\chi_B^{(3)} > 0$ and $\chi_C^{(3)} > 0$, all the finite singular points are complex and we get the configuration *Config. H.2*.

In the case $\chi_A^{(3)} > 0$, the singularities $M_{1,2}$ are real and we arrive at the following conditions and configurations:

- $\chi_D^{(3)} \neq 0$ and $\chi_C^{(3)} < 0 \Rightarrow$ *Config. H.17*;
- $\chi_D^{(3)} \neq 0$ and $\chi_C^{(3)} > 0 \Rightarrow$ *Config. H.18*;
- $\chi_D^{(3)} = 0 \Rightarrow$ *Config. H.21*.

And in the case $\chi_A^{(3)} = 0$, the singular points $M_{1,2}$ have collapsed and $M_{3,4}$ are complex, obtaining the configuration *Config. H.8*.

3.2.1.2 *The case $\beta_6 = 0$.* Then $f = c$ and hence $\gamma_1 = 0$. We calculate

$$\beta_2 = c(h-1)(h+1)/2, \quad \beta_7 = -2(2h-1)(2h+1)$$

and we analyze two subcases: $\beta_2 \neq 0$ and $\beta_2 = 0$.

3.2.1.2.1 *The subcase $\beta_2 \neq 0$.* Then $c \neq 0$ and we obtain the systems

$$\frac{dx}{dt} = a + cx - hx^2 + (h-1)xy, \quad \frac{dy}{dt} = b + cy - (h+1)xy + hy^2. \quad (79)$$

a) *The possibility $\beta_7 \neq 0$.* Then $(2h-1)(2h+1) \neq 0$ and, according to Theorem 3, for the existence of at least one invariant hyperbola for systems (79), it is necessary and sufficient the conditions $\gamma_8 = 0$ and $\beta_{10}\mathcal{R}_7 \neq 0$. So, we calculate

$$\begin{aligned}\gamma_8 &= 42(h-1)(h+1)\mathcal{E}_2\mathcal{E}_3, & \beta_{10} &= -2(3h-1)(3h+1), \\ \mathcal{E}_2 &= -2c^2(h-1)(2h-1) - 2a(h-1)(3h-1)^2 + b(2h-1)(3h-1)^2, \\ \mathcal{E}_3 &= -2c^2(h+1)(2h+1) + 2b(h+1)(3h+1)^2 - a(2h+1)(3h+1)^2.\end{aligned}$$

We observe that the condition $\gamma_8 = 0$ is equivalent to $\mathcal{E}_2\mathcal{E}_3 = 0$ and due to the change $(x, y, a, b, c, h) \mapsto (y, x, b, a, c, -h)$, we may assume that the condition $\mathcal{E}_2 = 0$ holds.

Since $\beta_7\beta_{10} \neq 0$, we could write the condition $\mathcal{E}_2 = 0$ as $c = c_1(3h-1)$, $b = b_1(h-1)$ and $a = (b_1 - 2c_1^2)(2h-1)/2$. Then, we apply the reparametrization $b_1 = ac_1^2$ and $a = 2a_1$. Finally, since $c_1 \neq 0$ (due to $c \neq 0$), we could apply the rescaling $(x, y, t) \mapsto (c_1x, c_1y, t/c_1)$ and assume $c_1 = 1$. Thus, setting the old parameter a instead of a_1 , we arrive at the 2-parameter family of systems

$$\begin{aligned}\frac{dx}{dt} &= (a-1)(2h-1) + (3h-1)x - hx^2 + (h-1)xy, \\ \frac{dy}{dt} &= 2a(h-1) + (3h-1)y - (h+1)xy + hy^2,\end{aligned}\tag{80}$$

with the conditions

$$(a-1)(h-1)(h+1)(2h-1)(2h+1)(3h-1)(3h+1) \neq 0.\tag{81}$$

These systems possess a couple of parallel invariant lines and an invariant hyperbola:

$$\begin{aligned}\mathcal{L}_{1,2}(x, y) &= h(x-y)^2 - (3h-1)(x-y) + 2h - a - 1 = 0, \\ \Phi(x, y) &= 1 - a - 2x + x(x-y) = 0.\end{aligned}\tag{82}$$

We remark that, since

$$\text{Discriminant} [\mathcal{L}_{1,2}(x, y), x-y] = (h-1)^2 + 4ah,$$

these lines are complex (respectively real) if $(h-1)^2 + 4ah < 0$ (respectively $(h-1)^2 + 4ah > 0$).

We calculate

$$\delta_4 = 3(h-1)(2h-1)[(h-1)^2(2h+1) + a(3h+1)^2]/2$$

and we consider two cases: $\delta_4 \neq 0$ and $\delta_4 = 0$.

α_1) *The case $\delta_4 \neq 0$.* In this case we have $(h-1)^2(2h+1) + a(3h+1)^2 \neq 0$ and hence $\Phi(x, y) = 0$ (see (82)) is the unique invariant hyperbola. Since $B_1 = 0$ for systems (80), we calculate

$$B_2 = -1296a(a-1)(h-1)^3(h+1)^2(2h-1)(x-y)^4.$$

α) *The subcase $B_2 \neq 0$.* Then $a \neq 0$ and, since $\mu_0 = h^2$, we consider two possibilities: $\mu_0 \neq 0$ and $\mu_0 = 0$.

α_1) The possibility $\mu_0 \neq 0$. So we get $h \neq 0$ and the finite singularities of systems (80) are of multiplicity 4, and their coordinates are $M_i(x_i, y_i)$:

$$x_{1,2} = \frac{h+1 \pm \sqrt{(h-1)^2 + 4ah}}{2}, \quad y_{1,2} = \frac{(h-1)[h-1 \pm \sqrt{(h-1)^2 + 4ah}]}{2h},$$

$$x_{3,4} = \frac{(2h-1)[h+1 \pm \sqrt{(h-1)^2 + 4ah}]}{2h}, \quad y_{3,4} = h-1 \pm \sqrt{(h-1)^2 + 4ah}.$$

We observe that the singular points $M_{1,2}$ are located on the hyperbola and on the invariant lines, whereas the singularities $M_{3,4}$ are located on the invariant lines.

Concerning the singular points $M_{1,2}$, we see that $x_1x_2 = h(1-a)$ and hence $\text{sign}(h(a-1))$ detects the location of these singularities on the same or different branches of the hyperbola. Moreover, the position of the hyperbola is governed by $\text{sign}(a-1)$.

In order to detect when the singularities $M_{3,4}$ also belong to the hyperbola, we consider (82) and we calculate

$$\Phi(x, y)|_{\{x=x_{3,4}, y=y_{3,4}\}} = \frac{\tilde{A} \pm [(h+1)(2h-1)\sqrt{(h-1)^2 + 4ah}]}{2h^2} \equiv \Omega''_{3,4}(a, g, h)$$

where $\tilde{A} = 2ah(1-3h) + (1-h)(1-h+2h^2)$, and we observe that at least one of the singular points M_3 or M_4 belongs to the hyperbola (82) if and only if

$$\Omega''_3\Omega''_4 = \frac{(a-1)[a(3h-1)^2 + 2(h-1)^3]}{h^2} = 0.$$

On the other hand, for systems (80), we calculate the invariant polynomials

$$\chi_A^{(7)} = (h-1)^2(h+1)^2[(h-1)^2 + 4ah]/16,$$

$$\chi_B^{(7)} = 6480(a-1)(h-1)^2[(h-1)^2(2h+1) + a(3h+1)^2]^2,$$

$$\chi_C^{(7)} = 2160h(1-a)(h-1)^2[(h-1)^2(2h+1) + a(3h+1)^2]^2,$$

and we conclude that $\text{sign}(\chi_A^{(7)}) = \text{sign}((h-1)^2 + 4ah)$ (if $(h-1)^2 + 4ah \neq 0$), $\text{sign}(\chi_B^{(7)}) = \text{sign}(a-1)$, $\text{sign}(\chi_C^{(7)}) = \text{sign}(h(1-a))$ and at least one of the singular points M_3 or M_4 belongs to the hyperbola if and only if $a(3h-1)^2 + 2(h-1)^3 = 0$.

i) The case $\chi_A^{(7)} < 0$. Then all the finite singular points are complex as well as the pair of invariant lines. Moreover, the condition $\chi_A^{(7)} < 0$ (i.e. $(h-1)^2 + 4ah < 0$) yields $ah < 0$. Combining this inequality with $\chi_B^{(7)} < 0$ (i.e. $a-1 < 0$) (respectively $\chi_B^{(7)} > 0$ (i.e. $a-1 > 0$)), we obtain $h < 0$ (respectively $h > 0$) and hence $\chi_C^{(7)} < 0$ (respectively $\chi_C^{(7)} > 0$). So, we arrive at the configuration *Config. H.78* if $\chi_B^{(7)} < 0$ and *Config. H.79* if $\chi_B^{(7)} > 0$.

ii) The case $\chi_A^{(7)} > 0$. Then all the finite singular points and the pair of invariant lines are real. In this sense, according to the position of the finite singular points on the hyperbola and on the invariant lines, we may have different configurations.

We calculate

$$(x_1 - x_4)(x_2 - x_3) = -\frac{a(3h-1)^2 + 2(h-1)^3}{h},$$

$$(x_1 - x_4) - (x_2 - x_3) = \frac{(3h-1)\sqrt{(h-1)^2 + 4ah}}{h}, \quad (x_1 - x_4) + (x_2 - x_3) = \frac{(1-h)(h+1)}{h}$$

and we observe that $\text{sign}((x_1 - x_4)(x_2 - x_3))$, $\text{sign}((x_1 - x_4) - (x_2 - x_3))$ and $\text{sign}((x_1 - x_4) + (x_2 - x_3))$ govern the position of the four finite singularities along the hyperbola and the invariant lines. More exactly, if $(x_1 - x_4)(x_2 - x_3) < 0$ (respectively $(x_1 - x_4)(x_2 - x_3) > 0$), then the $\text{sign}((x_1 - x_4) - (x_2 - x_3))$ (respectively $\text{sign}((x_1 - x_4) + (x_2 - x_3))$) distinguishes the position of M_3 and M_4 with respect to the hyperbola.

On the other hand, we calculate

$$\begin{aligned}\chi_D^{(7)} &= 3(h-1)^2(h+1)^2[a(3h-1)^2 + 2(h-1)^3]/8, \\ \beta_{10} &= -2(3h-1)(3h+1), \quad N = 9(h-1)(h+1)(x-y)^2.\end{aligned}$$

We consider two subcases: $\chi_D^{(7)} \neq 0$ and $\chi_D^{(7)} = 0$.

ii.1) *The subcase $\chi_D^{(7)} \neq 0$.* In this case the singularities $M_{3,4}$ do not belong to the hyperbola and we need to distinguish when the singular points $M_{1,2}$ are located on different or on the same branch.

ii.1.1) *The possibility $\chi_C^{(7)} < 0$.* Then $M_{1,2}$ are located on different branches of the hyperbola and, if $\chi_B^{(7)} < 0$, we obtain $a < 0$ and $h < 0$, and hence $\chi_D^{(7)} < 0$. So, we get the configuration *Config. H.96*.

In the case $\chi_B^{(7)} > 0$, we observe that the condition $\chi_D^{(7)} < 0$ implies $N < 0$. So, we arrive at the following conditions and configurations:

- $\chi_D^{(7)} < 0 \Rightarrow \text{Config. H.99};$
- $\chi_D^{(7)} > 0$ and $\beta_{10} < 0 \Rightarrow \text{Config. H.95};$
- $\chi_D^{(7)} > 0$ and $\beta_{10} > 0 \Rightarrow \text{Config. H.94}.$

ii.1.2) *The possibility $\chi_C^{(7)} > 0$.* Then $M_{1,2}$ are located on the same branch of the hyperbola.

If $\chi_B^{(7)} < 0$, the condition $\chi_D^{(7)} > 0$ implies $\beta_{10} < 0$ and we obtain the following conditions and configurations:

- $\chi_D^{(7)} < 0$ and $N < 0 \Rightarrow \text{Config. H.100};$
- $\chi_D^{(7)} < 0$ and $N > 0 \Rightarrow \text{Config. H.98};$
- $\chi_D^{(7)} > 0 \Rightarrow \text{Config. H.97}.$

In the case $\chi_B^{(7)} > 0$, the condition $\chi_D^{(7)} < 0$ implies $\beta_{10} < 0$. Moreover, if $\chi_D^{(7)} > 0$, independently of $\text{sign}(N)$, we are led to the same configuration. So, considering the claim stated in the next paragraph, we arrive at the configuration *Config. H.93* if $\chi_D^{(7)} < 0$ and *Config. H.92* if $\chi_D^{(7)} > 0$.

We claim that, if $\chi_C^{(7)} > 0$ and $\chi_B^{(7)} > 0$ (i.e. the singular points $M_{1,2}$ are located on the same branch and the hyperbola is positioned in the sense of $\chi_B^{(7)} > 0$), we could not have the configuration with the singular points $M_{3,4}$ located inside the region delimited by both branches of the hyperbola.

Indeed, suppose the contrary, that this configuration is realizable. Then the conditions $\chi_A^{(7)} > 0$, $\chi_B^{(7)} > 0$ and $\chi_C^{(7)} > 0$ are necessary and these conditions are equivalent to

$$(h-1)^2 + 4ah > 0, \quad a-1 > 0, \quad h < 0.$$

We assume that M_3 and M_4 are located inside the region delimited by both branches of the hyperbola. We observe that inside this region we also have the origin of coordinates (because $\Phi(0, 0) = 1 - a < 0$). Therefore we must have $\Omega_3''\Omega_4'' > 0$ and $\text{sign}(\Omega_3'' + \Omega_4'') = \text{sign}(\tilde{A}) = \text{sign}(1 - a)$. Hence the condition $\tilde{A} < 0$ must hold. However, the conditions $(h - 1)^2 + 4ah > 0$ and $h < 0$ imply

$$\tilde{A} = 2ah(1 - 3h) + (1 - h)(1 - h + 2h^2) \equiv \frac{1}{2}[(1 - 3h)[(h - 1)^2 + 4ah] + (1 - h)(h + 1)^2] > 0,$$

and this proves our claim.

ii.2) The subcase $\chi_D^{(7)} = 0$. Then $a = -2(h - 1)^3/(3h - 1)^2$ and the singular points M_4 coalesces with the singularity M_1 . We note that the hyperbola divides the plane into three regions: $\Phi(x, y) < 0$, $\Phi(x, y) > 0$ and $\Phi(x, y) = 0$, and the singular point M_3 could be located only in the first two regions. Moreover,

$$\Phi(M_3) = -\frac{(2h - 1)(h - 1)(h + 1)^2}{h^2(3h - 1)}$$

and, in this case, we have

$$\mathcal{L}_1 = x - y + \frac{3h - 1 - 4h^2}{h(3h - 1)} = 0, \quad \mathcal{L}_2 = x - y + \frac{3 - 5h}{3h - 1} = 0.$$

We calculate

$$\chi_A^{(7)} = (h - 1)^4(h + 1)^4/(16(3h - 1)^2), \quad \chi_B^{(7)} = -58320(2h - 1)(h - 1)^6(h + 1)^6/(3h - 1)^6, \\ \chi_C^{(7)} = 19440h(2h - 1)(h - 1)^6(h + 1)^6/(3h - 1)^6, \quad N = 9(h - 1)(h + 1)(x - y)^2.$$

Due to conditions (81), we have $\chi_A^{(7)} > 0$, $\text{sign}(\chi_B^{(7)}) = -\text{sign}(2h - 1)$, $\text{sign}(\chi_C^{(7)}) = -\text{sign}(h(2h - 1))$ and $\text{sign}(N) = -\text{sign}((h - 1)(h + 1))$. Moreover, $\mathcal{L}_1 - \mathcal{L}_2 = (h - 1)(h + 1)/[h(3h - 1)]$.

If $\chi_B^{(7)} < 0$ (i.e $h > 1/2$), we have $\chi_C^{(7)} > 0$ and $\text{sign}(\Phi(M_3)) = -\text{sign}(\mathcal{L}_1 - \mathcal{L}_2) = -\text{sign}(N)$. Then we get the configuration *Config. H.89* if $N < 0$ and *Config. H.90* if $N > 0$.

In the case $\chi_B^{(7)} > 0$ (i.e $h < 1/2$), the condition $\chi_C^{(7)} < 0$ implies $N < 0$ (then $x_2 - x_3 < 0$), obtaining the configuration *Config. H.88*. If $\chi_C^{(7)} > 0$ (then $\Phi(M_3) > 0$), independently of the sign of N , we get the configuration *Config. H.87*.

iii) The case $\chi_A^{(7)} = 0$. Then we have two double singular points (namely $M_1 = M_2$ and $M_3 = M_4$) and a double invariant line. The condition $\chi_A^{(7)} = 0$ yields $a = -(h - 1)^2/(4h)$ and hence $\chi_C^{(7)} > 0$ and $\text{sign}(\chi_B^{(7)}) = \text{sign}(\chi_D^{(7)}) = -\text{sign}(h)$.

We observe that, if $\chi_B^{(7)} > 0$, independently of $\text{sign}(\beta_{10})$ and $\text{sign}(N)$, we are conducted to the same configuration. Thus, we get the following conditions and configurations:

- $\chi_B^{(7)} < 0$ and $N < 0 \Rightarrow \text{Config. H.103}$;
- $\chi_B^{(7)} < 0$ and $N > 0 \Rightarrow \text{Config. H.102}$;
- $\chi_B^{(7)} > 0 \Rightarrow \text{Config. H.101}$.

α_2) *The possibility* $\mu_0 = 0$. Then $h = 0$ and, since we also obtain $\mu_1 = 0$ and $\mu_2 = xy$, two finite singularities of systems (80) have gone to infinity and collapsed with $[1, 0, 0]$ and $[0, 1, 0]$. The remaining two finite singularities have the coordinates $M_i(x_i, y_i)$:

$$x_1 = 1, y_1 = -a, \quad x_2 = a - 1, y_2 = -2.$$

In this case, the invariant hyperbola remains the same, whereas one of the invariant lines (82) goes to infinity and hence the line of infinity $Z = 0$ becomes double (see Lemma 3). The remaining invariant line is expressed by $x - y - (a + 1) = 0$.

We observe that the singular point M_1 is the intersection of the hyperbola and the straight line, whereas M_2 is generically located on the line and outside the hyperbola.

However, M_2 could be located on the hyperbola if and only if

$$\Phi(x_2, y_2) = (a - 1)(a - 2) = 0,$$

which is possible if and only if $a - 2 = 0$, due to conditions (81).

For systems (80) with $h = 0$, we calculate

$$\chi_B^{(7)} = 6480(a - 1)(a + 1)^2, \quad \chi_D^{(7)} = 3(a - 2)/8.$$

We note that, if $\chi_B^{(7)} < 0$, then $a < 1$ and hence $\chi_D^{(7)} < 0$. So, we have the following conditions and configurations:

- $\chi_B^{(7)} < 0 \Rightarrow \text{Config. H.106}$;
- $\chi_B^{(7)} > 0$ and $\chi_D^{(7)} < 0 \Rightarrow \text{Config. H.105}$;
- $\chi_B^{(7)} > 0$ and $\chi_D^{(7)} > 0 \Rightarrow \text{Config. H.107}$;
- $\chi_B^{(7)} > 0$ and $\chi_D^{(7)} = 0 \Rightarrow \text{Config. H.104}$.

β) *The subcase* $B_2 = 0$. Then $a = 0$ and we arrive at the family of systems

$$\frac{dx}{dt} = 1 - 2h + (3h - 1)x - hx^2 + (h - 1)xy, \quad \frac{dy}{dt} = (3h - 1)y - (h + 1)xy + hy^2, \quad (83)$$

with the conditions

$$(h - 1)(h + 1)(2h - 1)(2h + 1)(3h - 1)(3h + 1) \neq 0. \quad (84)$$

These systems possess three invariant lines and an invariant hyperbola

$$\begin{aligned} \mathcal{L}_1(x, y) &= x - y - 1 = 0, & \mathcal{L}_2(x, y) &= h(x - y) + 1 - 2h = 0, \\ \mathcal{L}_3(x, y) &= y = 0, & \Phi(x, y) &= 1 - 2x + x(x - y) = 0. \end{aligned} \quad (85)$$

Since $\mu_0 = h^2$, we consider again the possibilities: $\mu_0 \neq 0$ and $\mu_0 = 0$.

β_1) The possibility $\mu_0 \neq 0$. Then $h \neq 0$ and the finite singularities of systems (83) are of multiplicity 4, and their coordinates are $M_i(x_i, y_i)$:

$$x_1 = 1, y_1 = 0, \quad x_2 = h, y_2 = \frac{(h-1)^2}{h}, \quad x_3 = 2h-1, y_3 = 2(h-1), \quad x_4 = \frac{2h-1}{h}, y_4 = 0.$$

We observe that the singular points $M_{1,2}$ are located on the hyperbola, M_1 is located on the lines $\mathcal{L}_1 = 0$ and $\mathcal{L}_3 = 0$, M_2 is located on the line $\mathcal{L}_2 = 0$, M_3 is located on the line $\mathcal{L}_1 = 0$ and M_4 is located on the lines $\mathcal{L}_2 = 0$ and $\mathcal{L}_3 = 0$.

Concerning the position of these singularities with relation to the invariant lines and the invariant hyperbola, we have:

- the location of M_1 and M_2 on the branches of the hyperbola: $\text{sign}(x_1 x_2) = \text{sign}(h)$;
- M_3 and M_4 could not belong to the hyperbola, since $\Phi(x_3, y_3) = 2(1-h) \neq 0$ and $\Phi(x_4, y_4) = (h-1)^2/h^2 \neq 0$, due to conditions (84);
- the position of the line $\mathcal{L}_2 = 0$ with respect to the line $\mathcal{L}_1 = 0$: $\text{sign}(\mathcal{L}_1 - \mathcal{L}_2) = \text{sign}(h(h-1))$;
- the position of M_1 and M_4 on $\mathcal{L}_3 = 0$: $\text{sign}(x_1 - x_4) = \text{sign}(h(1-h))$;
- the position of M_2 and M_4 on $\mathcal{L}_2 = 0$: $\text{sign}(x_2 - x_4) = \text{sign}(h)$;
- the position of M_1 and M_3 on $\mathcal{L}_1 = 0$: $\text{sign}(x_1 - x_3) = \text{sign}(1-h)$.

On the other hand, for systems (83), we calculate the invariant polynomials

$$\chi_C^{(7)} = 2160 h(h-1)^6(2h+1)^2, \quad N = 9(h-1)(h+1)(x-y)^2.$$

We observe that the condition $\chi_C^{(7)} < 0$ implies that $\text{sign}(h-1)$ is controlled and we have the unique configuration given by *Config. H.111*.

In the case $\chi_C^{(7)} > 0$, we obtain the configuration *Config. H.112* if $N < 0$ and *Config. H.110* if $N > 0$.

β_2) The possibility $\mu_0 = 0$. Then $h = 0$ and, since we also obtain $\mu_1 = 0$ and $\mu_2 = xy$, two finite singularities of systems (80) have gone to infinity and collapsed with $[1, 0, 0]$ and $[0, 1, 0]$. The remaining two finite singularities have the coordinates $M_i(x_i, y_i)$:

$$x_1 = -1, y_1 = -2, \quad x_2 = 1, y_2 = 0.$$

In this case, the invariant hyperbola remains the same (since it does not depend on h), whereas the invariant line $\mathcal{L}_2 = 0$ goes to infinity and hence the line of infinity $Z = 0$ becomes double and we obtain only one configuration given by *Config. H.116*.

α_2) The case $\delta_4 = 0$. In this case, the condition $(h-1)^2(2h+1) + a(3h+1)^2 = 0$ yields $a = -(h-1)^2(2h+1)/(3h+1)^2$, which leads to the family of systems

$$\begin{aligned} \frac{dx}{dt} &= \frac{2(h+1)^3(1-2h)}{(3h+1)^2} + (3h-1)x - hx^2 + (h-1)xy, \\ \frac{dy}{dt} &= \frac{2(1-h)^3(2h+1)}{(3h+1)^2} + (3h-1)y - (h+1)xy + hy^2, \end{aligned} \tag{86}$$

with the conditions

$$(h-1)(h+1)(2h-1)(2h+1)(3h-1)(3h+1) \neq 0. \quad (87)$$

These systems possess two invariant lines and two invariant hyperbolas

$$\begin{aligned} \mathcal{L}_1(x, y) &= x - y - \frac{4h}{3h+1} = 0, & \mathcal{L}_2(x, y) &= x - y - \frac{5h^2-1}{h(3h+1)} = 0, \\ \Phi_1(x, y) &= \frac{2(h+1)^3}{(3h+1)^2} - 2x + x(x-y) = 0, & \Phi_2(x, y) &= \frac{2(1-h)^3}{(3h+1)^2} + \frac{2(3h-1)}{3h+1}x - y(x-y) = 0. \end{aligned} \quad (88)$$

Since $\mu_0 = h^2$, we consider again the possibilities: $\mu_0 \neq 0$ and $\mu_0 = 0$.

α) *The subcase $\mu_0 \neq 0$.* Then $h \neq 0$ and the four finite singularities of systems (86) have coordinates $M_i(x_i, y_i)$, where:

$$\begin{aligned} x_1 &= \frac{(h+1)^2}{3h+1}, & y_1 &= \frac{(h-1)^2}{3h+1}, & x_2 &= \frac{2h(h+1)}{3h+1}, & y_2 &= \frac{(2h+1)(h-1)^2}{h(3h+1)}, \\ x_3 &= \frac{2(h+1)(2h-1)}{3h+1}, & y_3 &= \frac{2(h-1)(2h+1)}{3h+1}, & x_4 &= \frac{(2h-1)(h+1)^2}{h(3h+1)}, & y_4 &= \frac{2h(h-1)}{3h+1}. \end{aligned}$$

We observe that the singular point M_1 is located on both hyperbolas and on the line $\mathcal{L}_1 = 0$, M_2 is located on the hyperbola $\Phi_1 = 0$ and on the line $\mathcal{L}_2 = 0$, M_3 is located on the line $\mathcal{L}_1 = 0$ and M_4 is located on the hyperbola $\Phi_2 = 0$ and on the line $\mathcal{L}_2 = 0$.

Concerning the position of the singular points on the lines and hyperbolas, we observe that the position of M_1 and M_3 on $\mathcal{L}_1 = 0$ is governed by $\text{sign}(x_1 - x_3) = \text{sign}((h-1)(h+1)(3h+1))$ and the position of M_2 and M_4 on $\mathcal{L}_2 = 0$ is governed by $\text{sign}(x_2 - x_4) = \text{sign}(h(h-1)(h+1)(3h+1))$. Moreover, the position of the hyperbolas is governed by $\text{sign}((h-1)(h+1))$.

We observe that, in the case $(h-1)(h+1) < 0$, we have $-1 < h < 1$. Then, analyzing the sign of the expression $h(3h+1)$, we verify that all the possible configurations for these values of the parameter coincide. Analogously, we obtain the same configurations by analyzing the sign of $h(3h+1)$ subjected to $(h-1)(h+1) > 0$. So, it is sufficient to only study $\text{sign}((h-1)(h+1))$.

Thus, we conclude that $\text{sign}(N) = \text{sign}((h-1)(h+1))$ and we arrive at the configuration given by *Config. H.140* if $N < 0$ and *Config. H.139* if $N > 0$.

β) *The subcase $\mu_0 = 0$.* Then $h = 0$ and two finite singular points have gone to infinity and coalesced with $[1, 0, 0]$ and $[0, 1, 0]$, since $\mu_1 = 0$ and $\mu_2 = xy$. The remaining two finite singularities have the coordinates $M_i(x_i, y_i)$, where

$$x_1 = -2, \quad y_1 = -2, \quad x_2 = 1, \quad y_2 = 1.$$

In this case, both invariant hyperbolas remain the same (since they do not depend on h), whereas the invariant line $\mathcal{L}_2 = 0$ goes to infinity and hence the line of infinity $Z = 0$ becomes double (see Lemma 3) and we obtain only one configuration given by *Config. H.146*.

b) *The possibility $\beta_7 = 0$.* We recall that the conditions $\beta_6 = 0$ and $\beta_2 \neq 0$ imply $f = c \neq 0$, and then we arrive at systems (79). As earlier, via a time rescaling, we may assume $c = 1$. Moreover,

the condition $\beta_7 = 0$ implies $(2h - 1)(2h + 1) = 0$ and, without loss of generality, we could choose $h = 1/2$, otherwise we apply the change $(x, y, t, a, b, h) \mapsto (-y, -x, -t, b, a, -h)$, which keeps the systems (79) and changes the sign of h .

Now, according to Theorem 3, for the existence of at least one hyperbola for systems (79), it is necessary and sufficient the conditions $\gamma_9 = 0$ and $\mathcal{R}_8 \neq 0$. So, we calculate $\gamma_9 = 3a/2$ and, setting $a = 0$, we obtain the 1-parameter family of systems

$$\frac{dx}{dt} = x - x^2/2 - xy/2, \quad \frac{dy}{dt} = b + y - 3xy/2 + y^2/2, \quad (89)$$

with the condition $b + 4 \neq 0$.

These systems possess three invariant lines (two of them being parallel) and an invariant hyperbola

$$\begin{aligned} \mathcal{L}_{1,2}(x, y) &= (x - y)^2 - 2(x - y) + 2b = 0, & \mathcal{L}_3(x, y) &= x = 0, \\ \Phi(x, y) &= 4 + b - 4x + x(x - y) = 0. \end{aligned} \quad (90)$$

We remark that, since $\text{Discriminant}[\mathcal{L}_{1,2}(x, y), x - y] = 4(1 - 2b)$, these lines are complex (respectively real) if $2b - 1 < 0$ (respectively $2b - 1 > 0$).

We calculate $\delta_5 = 3(8 - 25b)/2$ and we consider two cases: $\delta_5 \neq 0$ and $\delta_5 = 0$.

\mathbf{b}_1) *The case $\delta_5 \neq 0$.* In this case we have $25b - 8 \neq 0$ and hence $\Phi(x, y) = 0$ (see (90)) is the unique invariant hyperbola. Since $B_1 = B_2 = 0$ for systems (89), we calculate

$$B_3 = -27bx^2(x - y)^2/4.$$

α) *The subcase $B_3 \neq 0$.* Then $b \neq 0$ and, since $\mu_0 = 1/4$, the finite singularities $M_i(x_i, y_i)$ of systems (89) are of total multiplicity 4, and their coordinates are

$$x_{1,2} = \frac{3 \pm \sqrt{1 - 2b}}{2}, \quad y_{1,2} = \frac{1 \mp \sqrt{1 - 2b}}{2}, \quad x_{3,4} = 0, \quad y_{3,4} = -1 \pm \sqrt{1 - 2b}.$$

We observe that the singular points $M_{1,2}$ are located on the hyperbola and on the invariant lines $\mathcal{L}_{1,2} = 0$, whereas the singularities $M_{3,4}$ are located on the intersections of the couple of parallel invariant lines with the third one.

Considering the singular points $M_{1,2}$, we see that $x_1x_2 = (b + 4)/2$ and hence $\text{sign}(b + 4)$ detects the location of these singularities on the same or different branches of the hyperbola. Moreover, the position of the hyperbola is governed by $\text{sign}(b + 4)$.

In order to detect when the singularities $M_{3,4}$ also belong to the hyperbola, we consider (90) and we calculate

$$[\Phi(x_3, y_3)][\Phi(x_4, y_4)] = (b + 4)^2 \neq 0,$$

otherwise the hyperbola splits into two lines. Thus none of the singular points M_3 or M_4 could belong to the hyperbola (90).

On the other hand, for systems (89), we calculate the invariant polynomials

$$\chi_A^{(7)} = 9(1 - 2b)/256, \quad \chi_C^{(7)} = 135(b + 4)(25b - 8)^2/8$$

and we conclude that $\text{sign}(\chi_A^{(7)}) = \text{sign}(1 - 2b)$ (if $2b - 1 \neq 0$) and due to $\delta_5 \neq 0$ (i.e. $25b - 8 \neq 0$) we have $\text{sign}(\chi_C^{(7)}) = \text{sign}(b + 4)$.

α_1) The possibility $\chi_A^{(7)} < 0$. Then all four finite singularities are complex as well as the invariant lines $\mathcal{L}_{1,2} = 0$ and we get the configuration shown in *Config. H.115*.

α_2) The possibility $\chi_A^{(7)} > 0$. Then all four finite singularities and the invariant lines $\mathcal{L}_{1,2} = 0$ are real and we obtain the configuration *Config. H.114* if $\chi_C^{(7)} < 0$ and *Config. H.113* if $\chi_C^{(7)} > 0$.

α_3) The possibility $\chi_A^{(7)} = 0$. Then we have two double finite singular points (namely, $M_1=M_2$ and $M_3=M_4$) and also the invariant lines $\mathcal{L}_{1,2} = 0$ collapse and we obtain a double invariant line. So, we arrive at the configuration *Config. H.117*.

β) The subcase $B_3 = 0$. Then $b = 0$ and we obtain a specific system possessing a fourth invariant line, namely $\mathcal{L}_4 = y = 0$. Then, we obtain the unique configuration *Config. H.119*.

b_2) The case $\delta_5 = 0$. Then $b = 8/25$ and again we obtain a concrete system, but now possessing a second hyperbola, namely $\Phi_2(x, y) = -4/25 - 4y/5 + y(x - y) = 0$. Moreover, we observe that, for systems (89) with $b = 8/25$, we have $B_3 = -54x^2(x - y)^2/25 \neq 0$ and hence there are no more invariant lines rather than the ones given in (90). So, we arrive at the unique configuration *Config. H.147*.

3.2.1.2.2 The subcase $\beta_2 = 0$. Then $c = 0$ and we obtain the systems

$$\frac{dx}{dt} = a - hx^2 + (h - 1)xy, \quad \frac{dy}{dt} = b - (h + 1)xy + hy^2. \quad (91)$$

a) The possibility $\beta_7 \neq 0$. Then $(2h - 1)(2h + 1) \neq 0$ and, since $\beta_{10} = -2(3h - 1)(3h + 1)$, we consider two cases: $\beta_{10} \neq 0$ and $\beta_{10} = 0$.

α_1) The case $\beta_{10} \neq 0$. Then $(3h - 1)(3h + 1) \neq 0$ and, according to Theorem 3, for the existence of at least one invariant hyperbola for systems (91), it is necessary and sufficient the conditions $\gamma_7\gamma_8 = 0$ and $\mathcal{R}_5 \neq 0$. So, we calculate

$$\begin{aligned} \gamma_7 &= 8(h - 1)(h + 1)\mathcal{E}_1, & \gamma_8 &= 42(h - 1)(h + 1)(3h - 1)^2(3h + 1)^2\mathcal{E}_2\mathcal{E}_3, \\ \mathcal{E}_1 &= a(2h + 1) + b(2h - 1), & \mathcal{E}_2 &= 2a(1 - h) + b(2h - 1), & \mathcal{E}_3 &= 2b(h + 1) - a(2h + 1). \end{aligned}$$

We observe that we could pass from the condition $\mathcal{E}_2 = 0$ to the condition $\mathcal{E}_3 = 0$ via the change $(x, y, a, b, h) \mapsto (y, x, b, a, -h)$, and any of these conditions is equivalent to $\gamma_8 = 0$. However, the condition $\mathcal{E}_1 = 0$ could not be replaced. So, we need to analyze the possibility $\gamma_7 = 0$ and then the possibility $\gamma_8 = 0$.

We calculate

$$\beta_8 = -6(4h - 1)(4h + 1), \quad \delta_2 = 2[(a + b)(128h^2 - 11) + (a - b)h(400h^2 - 49)].$$

α) The subcase $\beta_8^2 + \delta_2^2 \neq 0$. By Theorem 3 (see DIAGRAM 1 in this case systems (91) possess a single invariant hyperbola if and only if $\gamma_7\gamma_8 = 0$ and $\mathcal{R}_5 \neq 0$. We consider the cases $\gamma_7 = 0$ and $\gamma_8 = 0$ separately.

α_1) The possibility $\gamma_7 = 0$. Then $\mathcal{E}_1 = 0$ and we obtain a subfamily of systems (73) with $c = 0$. So, we arrive at the 2-parameter family of systems

$$\frac{dx}{dt} = a(2h - 1) - hx^2 + (h - 1)xy, \quad \frac{dy}{dt} = -a(2h + 1) - (h + 1)xy + hy^2, \quad (92)$$

for which $h \neq 0$, otherwise we get degenerate systems, and considering the condition $N\beta_7\beta_{10}\mathcal{R}_5(\beta_8^2 + \delta_2^2) \neq 0$, we have

$$ah(h - 1)(h + 1)(2h - 1)(2h + 1)(3h - 1)(3h + 1)(4h - 1)(4h + 1) \neq 0. \quad (93)$$

These systems possess two parallel invariant lines and the invariant hyperbola

$$\mathcal{L}_{1,2} = (x - y)^2 - 4a = 0, \quad \Phi(x, y) = a + xy = 0. \quad (94)$$

Since $\mu_0 = h^2 \neq 0$, these systems possess all four finite singularities on the finite part of the phase plane and their coordinates are $M_i(x_i, y_i)$, where

$$x_{1,2} = \pm\sqrt{a}, \quad y_{1,2} = \mp\sqrt{a}, \quad x_{3,4} = \pm(2h - 1)\sqrt{a}, \quad y_{3,4} = \pm(2h + 1)\sqrt{a}.$$

We observe that the singular points $M_{1,2}$ are located on the hyperbola and on the invariant lines $\mathcal{L}_{1,2} = 0$, whereas the singularities $M_{3,4}$ are located only on the invariant lines.

Considering the singular points $M_{1,2}$, we see that $x_1x_2 = -a$ and hence $\text{sign}(a)$ detects the location of these singularities on the same or different branches of the hyperbola. Moreover, the position of the hyperbola is also governed by $\text{sign}(a)$.

We point out that the singularities $M_{3,4}$ could not belong to the hyperbola since

$$[\Phi(x_3, y_3)][\Phi(x_4, y_4)] = 16a^2h^4 \neq 0,$$

due to conditions (93). On the other hand, we calculate $\chi_A^{(2)} = 80ah^6$ and we note that $\text{sign}(\chi_A^{(2)}) = \text{sign}(a)$. So, we arrive at the configurations given by *Config. H.80* if $\chi_A^{(2)} < 0$ and *Config. H.91* if $\chi_A^{(2)} > 0$.

α_2) The possibility $\gamma_8 = 0$. Then $\mathcal{E}_2 = 0$ and this is equivalent to the relations $a = a_1(2h - 1)$ and $b = 2a_1(h - 1)$, where a_1 is a new parameter. So, setting this reparametrization in (91) and replacing the old parameter a instead of a_1 , we arrive at the 2-parameter family of systems

$$\frac{dx}{dt} = a(2h - 1) - hx^2 + (h - 1)xy, \quad \frac{dy}{dt} = 2a(h - 1) - (h + 1)xy + hy^2, \quad (95)$$

with the conditions

$$a(h - 1)(h + 1)(2h - 1)(2h + 1)(3h - 1)(3h + 1)(4h - 1)(4h + 1) \neq 0. \quad (96)$$

These systems possess two parallel invariant lines and the invariant hyperbola

$$\mathcal{L}_{1,2} = (x - y)^2 - a/h = 0, \quad \Phi(x, y) = a - x(x - y) = 0. \quad (97)$$

We consider the coordinates $M_i(x_i, y_i)$ of the finite singular points of systems (95):

$$x_{1,2} = \pm\sqrt{ah}, \quad y_{1,2} = \pm\frac{(h - 1)\sqrt{ah}}{h}, \quad x_{3,4} = \pm\frac{(2h - 1)\sqrt{ah}}{h}, \quad y_{3,4} = \pm 2\sqrt{ah}.$$

We observe that the singular points $M_{1,2}$ are located on the hyperbola and on the invariant lines $\mathcal{L}_{1,2} = 0$, whereas the singularities $M_{3,4}$ are located only on the invariant lines.

Considering the singular points $M_{1,2}$, we see that $x_1x_2 = -ah$ and hence $\text{sign}(ah)$ detects the location of these singularities on the same or different branches of the hyperbola. Moreover, the position of the hyperbola is governed by $\text{sign}(a)$.

We remark that the singular points $M_{3,4}$ could not belong to the hyperbola since

$$[\Phi(x_3, y_3)][\Phi(x_4, y_4)] = \frac{a^2(3h-1)^2}{h^2} \neq 0,$$

due to conditions (96). On the other hand, we calculate

$$\chi_A^{(7)} = ah(h-1)^2(h+1)^2/4, \quad \chi_B^{(7)} = 6480a^3(h-1)^2(3h+1)^4$$

and we note that $\text{sign}(\chi_A^{(7)}) = \text{sign}(ah)$ and $\text{sign}(\chi_B^{(7)}) = \text{sign}(a)$.

If $\chi_A^{(7)} \neq 0$ (i.e. $h \neq 0$), we obtain the following conditions and configurations:

- $\chi_A^{(7)} < 0$ and $\chi_B^{(7)} < 0 \Rightarrow \text{Config. H.78}$;
- $\chi_A^{(7)} < 0$ and $\chi_B^{(7)} > 0 \Rightarrow \text{Config. H.79}$;
- $\chi_A^{(7)} > 0$ and $\chi_B^{(7)} < 0 \Rightarrow \text{Config. H.96}$;
- $\chi_A^{(7)} > 0$ and $\chi_B^{(7)} > 0 \Rightarrow \text{Config. H.95}$.

In the case $\chi_A^{(7)} = 0$ (i.e. $h = 0$), then we have $\mu_0 = \mu_1 = \mu_2 = \mu_3 = 0$ and $\mu_4 = a^2x^2y^2 \neq 0$. Thus, the four finite singularities have gone to infinity and two of them coalesced with $[1, 0, 0]$ and the other two of them coalesced with $[0, 1, 0]$. Moreover, the two invariant lines $\mathcal{L}_{1,2} = 0$ have also gone to infinity and hence the line of infinity $Z = 0$ is a triple invariant line for the system, because Z^2 is a double factor of the polynomials \mathcal{E}_1 and \mathcal{E}_2 (see Lemma 3).

Now, according to the sign (a) we have different position of the hyperbola and consequently distinct configurations. So, we get the configurations shown by *Config. H.108* if $\chi_B^{(7)} < 0$ and by *Config. H.109* if $\chi_B^{(7)} > 0$.

β) *The subcase $\beta_8 = \delta_2 = 0$.* Then the condition $\beta_8 = 0$ gives $(4h-1)(4h+1) = 0$ and, without loss of generality, we may assume $h = 1/4$ due to the change $(x, y, a, b, h) \mapsto (y, x, b, a, -h)$.

We calculate

$$\delta_2 = 6(b-3a), \quad \gamma_7 = -15(3a-b)/4, \quad \gamma_8 = 15435(3a-5b)(3a-b)/8192$$

and hence the condition $\delta_2 = 0$ yields $b = 3a$ and then $\gamma_7 = \gamma_8 = 0$. So we obtain the 1-parameter family of systems

$$\frac{dx}{dt} = a - x^2/4 - 3xy/4, \quad \frac{dy}{dt} = 3a - 5xy/4 + y^2/4, \quad (98)$$

with the condition $a \neq 0$.

These systems possess two parallel invariant lines and two invariant hyperbolas

$$\mathcal{L}_{1,2} = (x-y)^2 + 8a = 0, \quad \Phi_1(x, y) = 2a - xy = 0, \quad \Phi_2(x, y) = 2a + x(x-y) = 0. \quad (99)$$

Since $\mu_0 = 1/16 \neq 0$, all the four finite singularities are on the finite part of the phase plane and their coordinates are $M_i(x_i, y_i)$:

$$x_{1,2} = \pm\sqrt{-2a}, \quad y_{1,2} = \mp\sqrt{-2a}, \quad x_{3,4} = \pm\frac{\sqrt{-2a}}{2}, \quad y_{3,4} = \mp\frac{3\sqrt{-2a}}{2}.$$

We observe that the singular points $M_{1,2}$ are located on the first hyperbola $\Phi_1 = 0$, whereas the singularities $M_{3,4}$ are located on the second hyperbola $\Phi_2 = 0$. All singular points are located on the invariant lines $\mathcal{L}_{1,2} = 0$.

Considering the singular points $M_{1,2}$ (respectively $M_{3,4}$), we see that $x_1x_2 = 2a$ (respectively $x_3x_4 = a/2$) and hence $\text{sign}(a)$ detects the location of these singularities to be on the same or different branches of the hyperbolas that they are located on. Moreover, the position of the hyperbola is also governed by $\text{sign}(a)$.

We remark that the singular points $M_{1,2}$ (respectively $M_{3,4}$) could not belong to the hyperbola $\Phi_2 = 0$ (respectively $\Phi_1 = 0$) since

$$[\Phi_2(x_1, y_1)][\Phi_2(x_2, y_2)] = 4a^2 \neq 0, \quad [\Phi_1(x_3, y_3)][\Phi_1(x_4, y_4)] = a^2/4 \neq 0,$$

due to $a \neq 0$.

On the other hand, we calculate

$$\chi_A^{(7)} = -225a/2048$$

and we note that $\text{sign}(\chi_A^{(7)}) = -\text{sign}(a)$. So, we get the configurations shown by *Config. H.143* if $\chi_A^{(7)} < 0$ and *Config. H.141* if $\chi_A^{(7)} > 0$.

a₂) *The case $\beta_{10} = 0$.* Then $(3h - 1)(3h + 1) = 0$ and, without loss of generality, we may assume $h = 1/3$, since the case $h = -1/3$ could be brought to the case $h = 1/3$ via the change $(x, y, a, b, h) \mapsto (y, x, b, a, -h)$. So, we arrive at the systems

$$\frac{dx}{dt} = a - x^2/3 - 2xy/3, \quad \frac{dy}{dt} = b - 4xy/3 + y^2/3. \quad (100)$$

with the condition $a \neq 0$, possessing a pair of parallel invariant lines and a couple of invariant hyperbolas with parallel asymptotes

$$\mathcal{L}_{1,2}(x, y) = (x - y)^2 - 3(a - b) = 0, \quad \Phi_{1,2}(x, y) = 3a \pm \sqrt{3(4a - b)}x + x(x - y) = 0. \quad (101)$$

In accordance to Theorem 3, we have to analyze the following subcases: $\gamma_7 \neq 0$ and $\gamma_7 = 0$ and we calculate

$$\gamma_7 = -65(5a - b)/27, \quad \gamma_{10} = 8(4a - b)/27.$$

α) *The subcase $\gamma_7 \neq 0$.* Then we could not have other invariant hyperbolas rather than the ones in (101). Moreover, the hyperbolas (101) are complex if $\gamma_{10} < 0$, real if $\gamma_{10} > 0$ and they coincide if $\gamma_{10} = 0$. Then, we consider two possibilities: $\gamma_{10} < 0$ and $\gamma_{10} \geq 0$.

α_1) *The possibility $\gamma_{10} < 0$.* Then the hyperbolas (101) are complex. In this case, we set a new parameter $v \neq 0$ satisfying $4a - b = -3v^2$, which yields $b = 4a + 3v^2$ and we obtain the 2-parameter family of systems

$$\frac{dx}{dt} = a - x^2/3 - 2xy/3, \quad \frac{dy}{dt} = 4a + 3v^2 - 4xy/3 + y^2/3, \quad (102)$$

with the condition $av \neq 0$, possessing the invariant lines and invariant hyperbolas

$$\mathcal{L}_{1,2}(x, y) = (x - y)^2 + 9(a + v^2) = 0, \quad \Phi_{1,2}(x, y) = 3a \pm 3ivx + x(x - y) = 0. \quad (103)$$

We calculate

$$\mu_0 = 1/9, \quad B_1 = 0, \quad B_2 = -512a(4a + 3v^2)(x - y)^4$$

and we consider two cases: $B_2 \neq 0$ and $B_2 = 0$.

i) The case $B_2 \neq 0$. Then there are no other invariant lines rather than $\mathcal{L}_{1,2} = 0$ in (103). We calculate

$$\begin{aligned} \mu_0 = 1/9 \neq 0, \quad \mathbf{D} = -4096v^4(a + v^2)^2/3, \quad \mathbf{S} = 256v^2(a + v^2)(x - y)^2(2x + y)^2/2187, \\ \mathbf{R} = -16[(4a + 5v^2)x^2 + 2(2a + v^2)xy + (a + 2v^2)y^2]/81, \quad \mathbf{T} = -81\mathbf{R}\mathbf{S}/32. \end{aligned}$$

We claim that all four finite singular points are complex. Indeed, if $a + v^2 > 0$, we observe that

$$\text{Discriminant } [\mathbf{R}, x] = -1024v^2(a + v^2)y^2/729 < 0, \quad \text{Coefficient } [\mathbf{R}, y^2] = -16(a + 2v^2)/81 < 0$$

and hence $\mathbf{R} < 0$. Since $\mathbf{D} < 0$, by Proposition 1 all four finite singularities of systems (102) are complex.

Now, if $a + v^2 < 0$, then $\mathbf{D} < 0$ and $\mathbf{S} < 0$, and by Proposition 1 all four finite singularities of systems (102) are complex.

Finally, if $a + v^2 = 0$, then $\mathbf{D} = \mathbf{T} = 0$ and we have two collisions of finite singular points, i.e. we have two double singular points. As in any case we have only complex singularities, these double singular points are also complex. So, our claim is proved.

We calculate $\chi_A^{(7)} = -16(a + v^2)/81$ and we note that $\text{sign}(\chi_A^{(7)}) = -\text{sign}(a + v^2)$.

If $\chi_A^{(7)} < 0$, then the invariant lines are also complex and we get the configuration *Config. H.144*. In the case $\chi_A^{(7)} > 0$ the invariant lines are real and we arrive at the configuration *Config. H.145*. If $\chi_A^{(7)} = 0$, then the invariant lines collapse and become double, which leads to configuration *Config. H.153*.

ii) The case $B_2 = 0$. Then $4a + 3v^2 = 0$ and systems (102) have a third invariant line $y = 0$ and the lines $\mathcal{L}_{1,2} = 0$ are complex. So, we get the configuration *Config. H.151*.

$\alpha_2)$ The possibility $\gamma_{10} > 0$. In this case, we set the new parameter $v \neq 0$ satisfying $4a - b = 3v^2$, which yields $b = 4a - 3v^2$ and we obtain the 2-parameter family of systems

$$\frac{dx}{dt} = a - x^2/3 - 2xy/3, \quad \frac{dy}{dt} = 4a - 3v^2 - 4xy/3 + y^2/3, \quad (104)$$

with the condition $a \neq 0$, possessing the invariant lines and invariant hyperbolas

$$\mathcal{L}_{1,2}(x, y) = (x - y)^2 + 9(a - v^2) = 0, \quad \Phi_{1,2}(x, y) = 3a \pm 3vx + x(x - y) = 0. \quad (105)$$

Remark 11. We remark that, the condition $v = 0$ for systems (104) is equivalent to $\gamma_{10} = 0$.

We calculate

$$\mu_0 = 1/9, \quad B_1 = 0, \quad B_2 = -512a(4a - 3v^2)(x - y)^4$$

and we consider two cases: $B_2 \neq 0$ and $B_2 = 0$.

i) The case $B_2 \neq 0$. Then there is no other invariant line rather than $\mathcal{L}_{1,2} = 0$ in (105). Since $\mu_0 \neq 0$, all four finite singularities of systems (104) are on the finite part of the phase plane and their coordinates are $M_i(x_i, y_i)$, where

$$x_{1,2} = -v \pm \sqrt{v^2 - a}, \quad y_{1,2} = -v \mp 2\sqrt{v^2 - a}, \quad x_{3,4} = v \pm \sqrt{v^2 - a}, \quad y_{3,4} = v \mp 2\sqrt{v^2 - a}.$$

We observe that the singular points $M_{1,2}$ are located on the first hyperbola $\Phi_1 = 0$ and on the invariant lines $\mathcal{L}_{1,2} = 0$, whereas the singularities $M_{3,4}$ are located on the second hyperbola $\Phi_2 = 0$ and on the invariant lines $\mathcal{L}_{1,2} = 0$.

Considering the pairs of singular points $M_{1,2}$ and $M_{3,4}$, we see that $x_1x_2 = x_3x_4 = a$ and hence $\text{sign}(a)$ detects the location of these singularities to be on the same or different branches of the respective hyperbola they are located on.

We remark that the singular points $M_{1,2}$ (respectively $M_{3,4}$) could belong to the hyperbola $\Phi_2 = 0$ (respectively $\Phi_1 = 0$) if and only if

$$[\Phi_2(x_1, y_1)][\Phi_2(x_2, y_2)] = 36av^2 = 0, \quad [\Phi_1(x_3, y_3)][\Phi_1(x_4, y_4)] = 36av^2 = 0,$$

which are equivalent to $v = 0$. However by Remark 11 and the condition $\gamma_{10} > 0$ we have $v \neq 0$.

On the other hand, we calculate

$$\chi_A^{(7)} = 16(v^2 - a)/81, \quad \chi_C^{(3)} = 17039360 a(a + 3v^2)^2/9$$

and we conclude that $\text{sign}(\chi_A^{(7)}) = \text{sign}(v^2 - a)$ and $\text{sign}(\chi_C^{(3)}) = \text{sign}(a)$.

Since $v \neq 0$, the invariant hyperbolas $\Phi_{1,2} = 0$ are distinct. We observe that the condition $\chi_A^{(7)} \leq 0$ implies $a > 0$ (as $v \neq 0$) and consequently, $\chi_C^{(3)} > 0$. Moreover, if $\chi_A^{(7)} = 0$, then both invariant lines coalesce and we obtain the double invariant line $(x - y)^2 = 0$. So, we arrive at the following conditions and configurations:

- $\chi_A^{(7)} < 0 \Rightarrow \text{Config. H.142}$;
- $\chi_A^{(7)} > 0$ and $\chi_C^{(3)} < 0 \Rightarrow \text{Config. H.137}$;
- $\chi_A^{(7)} > 0$ and $\chi_C^{(3)} > 0 \Rightarrow \text{Config. H.138}$;
- $\chi_A^{(7)} = 0 \Rightarrow \text{Config. H.152}$.

ii) The case $B_2 = 0$. Then $a = 3v^2/4$ and we have a third invariant line $\mathcal{L}_3(x, y) = y = 0$ and the previous two lines could be factored as $\mathcal{L}_1(x, y) = 2x - 2y + 3v = 0$ and $\mathcal{L}_2(x, y) = 2x - 2y - 3v = 0$.

Since $a > 0$, we have

$$\chi_A^{(7)} = 4v^2/81 > 0, \quad \chi_C^{(3)} = 19968000v^2 > 0$$

and we obtain the unique configuration *Config. H.149*.

α_3 *The possibility* $\gamma_{10} = 0$. In this case according to Remark 11 we have $v = 0$, and then $\chi_A^{(7)} = -16a/81 \neq 0$. In this case, both hyperbola collapse and we get a double hyperbola. Furthermore, the singularities collapse two by two and we have two double singular points (namely $M_1 = M_3$ and $M_2 = M_4$).

It remains to observe that the condition $\chi_A^{(7)} < 0$ (respectively $\chi_A^{(7)} > 0$) implies $\chi_C^{(3)} > 0$ (respectively $\chi_C^{(3)} < 0$). So, we get the configuration *Config. H.155* if $\chi_A^{(7)} < 0$ and *Config. H.154* if $\chi_A^{(7)} > 0$.

β) *The subcase $\gamma_7 = 0$.* Then $b = 5a$ and we arrive at the 1-parameter family of systems

$$\frac{dx}{dt} = a - x^2/3 - 2xy/3, \quad \frac{dy}{dt} = 5a - 4xy/3 + y^2/3, \quad (106)$$

with the condition $a \neq 0$.

These systems possess a couple of parallel invariant lines, a pair of invariant hyperbolas with parallel asymptotes presented in (101) and a third hyperbola

$$\begin{aligned} \mathcal{L}_{1,2}(x, y) &= (x - y)^2 + 12a = 0, \\ \Phi_{1,2}(x, y) &= 3a \pm \sqrt{-3a}x + x(x - y) = 0, \quad \Phi_3(x, y) = xy - 3a = 0. \end{aligned} \quad (107)$$

Since $B_1 = 0$ and $B_2 = -2560a^2(x - y)^4 \neq 0$, systems (106) could not possess other invariant lines rather than the ones in (107). Moreover, we have $\mu_0 = 1/9 \neq 0$ and all the four singularities are on the finite part of the phase plane with coordinates $M_i(x_i, y_i)$, where

$$x_{1,2} = \pm\sqrt{-3a}, \quad y_{1,2} = \mp\sqrt{-3a}, \quad x_{3,4} = \pm\frac{\sqrt{-3a}}{3}, \quad y_{3,4} = \mp\frac{5\sqrt{-3a}}{3}.$$

We observe that all four singular points are located on the invariant lines and also: M_1 is located on the hyperbolas $\Phi_2 = 0$ and $\Phi_3 = 0$, M_2 is located on the hyperbolas $\Phi_1 = 0$ and $\Phi_3 = 0$, M_3 is located on the hyperbola $\Phi_1 = 0$ and M_4 is located on the hyperbola $\Phi_2 = 0$.

Concerning the position of the singularities on the hyperbolas, we have

- the position of M_2 and M_3 on $\Phi_1(x, y) = 0$ is controlled by $\text{sign}(x_2x_3) = \text{sign}(a)$;
- the position of M_1 and M_4 on $\Phi_2(x, y) = 0$ is controlled by $\text{sign}(x_1x_4) = \text{sign}(a)$;
- the position of M_1 and M_2 on $\Phi_3(x, y) = 0$ is controlled by $\text{sign}(x_2x_3) = \text{sign}(3a)$.

We also point out that due to $a \neq 0$, the singularities could be located on the hyperbolas only as it is described above.

We remark that, if $a > 0$, then the four singularities are complex as well as the pair of invariant hyperbolas $\Phi_{1,2}(x, y) = 0$ and the couple of invariant lines $\mathcal{L}_{1,2}(x, y) = 0$.

On the other hand, we calculate $\gamma_{10} = -8a/27$ and we conclude that $\text{sign}(\gamma_{10}) = -\text{sign}(a)$. So, we arrive at the configuration *Config. H.159* if $\gamma_{10} < 0$ and *Config. H.158* if $\gamma_{10} > 0$.

b) *The possibility $\beta_7 = 0$.* Then $(2h - 1)(2h + 1) = 0$ and, without loss of generality as earlier, we may assume $h = 1/2$. So, we obtain the systems

$$\frac{dx}{dt} = a - x^2/2 - xy/2, \quad \frac{dy}{dt} = b - 3xy/2 + y^2/2. \quad (108)$$

According to Theorem 3, the condition $\gamma_7 = 0$ is necessary and sufficient for the existence of invariant hyperbolas for systems (108). Moreover, this condition implies the existence of two such hyperbolas.

We calculate $\gamma_7 = -12a = 0$ and we obtain the 1-parameter family of systems

$$\frac{dx}{dt} = -x^2/2 - xy/2, \quad \frac{dy}{dt} = b - 3xy/2 + y^2/2. \quad (109)$$

with the condition $b \neq 0$.

These systems possess three invariant lines and two invariant hyperbolas

$$\begin{aligned} \mathcal{L}_{1,2}(x, y) &= (x - y)^2 + 2b = 0, & \mathcal{L}_3(x, y) &= x = 0, \\ \Phi_1(x, y) &= b - 2xy = 0, & \Phi_2(x, y) &= b + x(x - y) = 0. \end{aligned} \quad (110)$$

For systems (109) we calculate $B_1 = B_2 = 0$ and $B_3 = -27bx^2(x - y)^2/4 \neq 0$ and therefore by Lemma 2 systems (109) could not possess other invariant lines rather than the ones in (110). Since $\mu_0 = 1/4 \neq 0$, these systems have finite singularities of total multiplicity 4 with coordinates $M_i(x_i, y_i)$, where

$$x_{1,2} = \pm \frac{\sqrt{-2b}}{2}, \quad y_{1,2} = \mp \frac{\sqrt{-2b}}{2}, \quad x_{3,4} = 0, \quad y_{3,4} = \pm \sqrt{-2b}.$$

We observe that the singular points $M_{1,2}$ are located on the two hyperbolas and on the lines $\mathcal{L}_{1,2} = 0$ and the singularities $M_{3,4}$ are located on the three invariant lines.

Moreover, due $b \neq 0$ we deduce that the singular points $M_{3,4}$ could not belong to the hyperbolas. By the same argument the singular points $M_{1,2}$ could not belong to the invariant line $\mathcal{L}_3 = 0$.

Since $x_1x_2 = b/2$, the position of the singular points $M_{1,2}$ on the hyperbola is governed by $\text{sign}(b)$, as well as the position of the invariant hyperbolas.

We calculate $\chi_A^{(7)} = -9b/128$ and we conclude that $\text{sign}(\chi_A^{(7)}) = \text{sign}(b)$.

It is worth mentioning that, if $b > 0$, then all four singular points are complex as well as the couple of invariant lines $\mathcal{L}_{1,2} = 0$. So, we get the configuration *Config. H.150* if $\chi_A^{(7)} < 0$ and *Config. H.148* if $\chi_A^{(7)} > 0$.

3.2.2 The possibility $N = 0$

Since for systems (9) we have $\theta = -(g - 1)(h - 1)(g + h)/2 = 0$, we observe that the condition

$$N = (g - 1)(g + 1)x^2 + 2(g - 1)(h - 1)xy + (h - 1)(h + 1)y^2 = 0$$

implies the vanishing of two factors of θ . Then, without loss of generality, we may assume $g = 1 = h$, otherwise in the case $g + h = 0$ and $g - 1 \neq 0$ (respectively $h - 1 \neq 0$), we apply the change $(x, y, g, h) \mapsto (-y, x - y, 1 - g - h, g)$ (respectively $(x, y, g, h) \mapsto (y - x, -x, h, 1 - g - h)$) which preserves the form of such systems.

So, $g = h = 1$ and due to an additional translation we arrive at the systems

$$\frac{dx}{dt} = a + dy + x^2, \quad \frac{dy}{dt} = b + ex + y^2, \quad (111)$$

for which we calculate

$$\beta_1 = 4de, \quad \beta_2 = -2(d + e).$$

According to Theorem 3, a necessary condition for the existence of hyperbolas for these systems is $\beta_1 = 0$. This condition is equivalent to $de = 0$ and, without loss of generality, we may assume $e = 0$, due to the change $(x, y, a, b, d, e) \mapsto (y, x, b, a, e, d)$.

Then $\beta_2 = -2d$ and we analyze two cases: $\beta_2 \neq 0$ and $\beta_2 = 0$.

3.2.2.1 *The case $\beta_2 \neq 0$.* Then $d \neq 0$ and via the rescaling $(x, y, t) \mapsto (4d x, 4d y, t/(4d))$, we may assume $d = 4$. In this case, since $\beta_1 = 0$, according to Theorem 3 the conditions $\gamma_{11} = 0$ and $\mathcal{R}_9 \neq 0$ are necessary and sufficient for the existence of one invariant hyperbola.

We calculate $\gamma_{11} = -64(a - 4b + 1)$ and, setting $a = 4b - 1$, we obtain the 1-parameter family of systems

$$\frac{dx}{dt} = 4b - 1 + 4y + x^2, \quad \frac{dy}{dt} = b + y^2, \quad (112)$$

for which $\mathcal{R}_9 = 40(b + 1) \neq 0$. These systems possess the invariant lines and the invariant hyperbola

$$\mathcal{L}_{1,2}(x, y) = y^2 + b = 0, \quad \Phi(x, y) = b - 1 - x + 3y + y(x - y) = 0. \quad (113)$$

Since $B_1 = 0$ and $B_2 = -124416(b + 1)y^4 \neq 0$, systems (112) could not possess other invariant lines rather than the ones in (113). Moreover, $\mu_0 = 1 \neq 0$ implies that these systems possess finite singularities $M_i(x_i, y_i)$ of total multiplicity four and their coordinates are

$$x_{1,2} = -1 \pm 2\sqrt{-b}, \quad y_{1,2} = \pm\sqrt{-b}, \quad x_{3,4} = 1 \pm 2\sqrt{-b}, \quad y_{3,4} = \mp\sqrt{-b}.$$

We observe that the singular points $M_{1,2}$ are located on the hyperbola and on the lines, whereas the singularities $M_{3,4}$ are located on the invariant lines.

Moreover, at least one of the singular points $M_{3,4}$ could belong to the hyperbola if and only if

$$[\Phi(x_3, y_3)][\Phi(x_4, y_4)] = 4(b + 1)(4b + 1) = 0,$$

i.e. if and only if $4b + 1 = 0$.

Since $x_1 x_2 = 4(4b + 1)$, the position of the singular points $M_{1,2}$ on the hyperbola is governed by $\text{sign}(4b + 1)$, while the position of the invariant hyperbola is governed by $\text{sign}(b)$.

We calculate

$$\chi_A^{(8)} = -80b, \quad \chi_D^{(8)} = 80(4b + 1), \quad \mathcal{R}_9 = 40(b + 1)$$

and we conclude that $\text{sign}(\chi_A^{(8)}) = -\text{sign}(b)$ and $\text{sign}(\chi_D^{(8)}) = \text{sign}(4b + 1)$.

We observe that, if $b > 0$, then all four singularities and the invariant lines are complex. So, we arrive at the unique configuration *Config. H.79* if $\chi_A^{(8)} < 0$.

In the case $\chi_A^{(8)} > 0$, we get the following conditions and configurations:

- $\mathcal{R}_9 < 0$ *Config. H.96*;
- $\mathcal{R}_9 > 0$ and $\chi_D^{(8)} < 0 \Rightarrow$ *Config. H.93*;
- $\mathcal{R}_9 > 0$ and $\chi_D^{(8)} > 0 \Rightarrow$ *Config. H.92*;
- $\mathcal{R}_9 > 0$ and $\chi_D^{(8)} = 0 \Rightarrow$ *Config. H.87*.

If $\chi_A^{(8)} = 0$, then $b = 0$ and the invariant lines collapse and become double. Moreover, the singularity M_1 coalesces with M_3 , and so does M_2 with M_4 , and we have two double singular points, leading us to the configuration *Config. H.101*.

3.2.2.2 *The case $\beta_2 = 0$.* Then $d = 0$ and, according to Theorem 3 (see Diagram 1) we have at least one hyperbola if and only if the conditions (\mathfrak{C}_3) are satisfied, where by (\mathfrak{C}_3) we denote

$$(\mathfrak{C}_3) : (\beta_1 = 0) \cap ((\gamma_{12} = 0, \mathcal{R}_9 \neq 0) \cup (\gamma_{13} = 0)).$$

We observe that the condition $\gamma_{12} = 0$ leads to the existence of only one invariant hyperbola, whereas the condition $\gamma_{13} = 0$ leads to the existence of an infinite number of such hyperbolas.

$$\text{We calculate } \gamma_{12} = -128(a - 4b)(4a - b), \quad \gamma_{13} = 4(a - b).$$

3.2.2.2.1 *The subcase $\gamma_{12} = 0$.* Then $(a - 4b)(4a - b) = 0$ and, via the change $(x, y, a, b) \mapsto (y, x, b, a)$, we may assume $b = 4a$ and we arrive at the 1-parameter family of systems

$$\frac{dx}{dt} = a + x^2, \quad \frac{dy}{dt} = 4a + y^2, \quad a \neq 0. \quad (114)$$

These systems possess two couples of parallel invariant lines and the invariant hyperbola

$$\mathcal{L}_{1,2}(x, y) = x^2 + a = 0, \quad \mathcal{L}_{3,4}(x, y) = y^2 + 4a = 0, \quad \Phi(x, y) = a - x(x - y) = 0. \quad (115)$$

Since $B_1 = B_2 = 0$ and $B_3 = 36ax^2y^2 \neq 0$, systems (114) could not possess other invariant lines rather than the ones in (115). Moreover as $\mu_0 = 1 \neq 0$, by Lemma 1 the above systems possess finite singularities $M_i(x_i, y_i)$ of total multiplicity four and their coordinates are

$$x_{1,2} = \pm\sqrt{-a}, \quad y_{1,2} = \pm 2\sqrt{-a}, \quad x_{3,4} = \pm\sqrt{-a}, \quad y_{3,4} = \mp 2\sqrt{-a}.$$

We observe that all four singularities belong to the lines $\mathcal{L}_{1,2,3,4} = 0$. Moreover, the singular points $M_{1,2}$ are located on the hyperbola, whereas the singular points $M_{3,4}$ could not belong to the hyperbola due to $a \neq 0$.

Since $x_1x_2 = 4a$, the position of the singular points $M_{1,2}$ on the hyperbola is governed by $\text{sign}(a)$, as well as the position of the invariant hyperbola.

We calculate $\chi_A^{(2)} = -80a$ and we conclude that $\text{sign}(\chi_A^{(2)}) = -\text{sign}(a)$.

Since in the case $a > 0$ all four singularities and the invariant lines are complex, we arrive at the configuration *Config. H.120* if $\chi_A^{(2)} < 0$ and *Config. H.118* if $\chi_A^{(2)} > 0$.

3.2.2.2.2 *The subcase $\gamma_{13} = 0$.* Then $b = a$ and we arrive at the 1-parameter family of systems

$$\frac{dx}{dt} = a + x^2, \quad \frac{dy}{dt} = a + y^2, \quad a \neq 0. \quad (116)$$

These systems possess five invariant lines and the family of invariant hyperbolas

$$\begin{aligned} \mathcal{L}_{1,2}(x, y) = x^2 + a = 0, \quad \mathcal{L}_{3,4}(x, y) = y^2 + a = 0, \quad \mathcal{L}_5(x, y) = x - y = 0, \\ \Phi(x, y) = 2a - r(x - y) + 2xy = 0, \quad r \in \mathbb{C}. \end{aligned} \quad (117)$$

Since $\mu_0 = 1 \neq 0$ the above systems possess finite singularities $M_i(x_i, y_i)$ of total multiplicity four and their coordinates are

$$x_{1,2} = \pm\sqrt{-a}, \quad y_{1,2} = \pm\sqrt{-a}, \quad x_{3,4} = \pm\sqrt{-a}, \quad y_{3,4} = \mp\sqrt{-a}.$$

We observe that all four singularities belong to the lines $\mathcal{L}_{1,2,3,4} = 0$. Moreover, the singular points $M_{1,2}$ are located on the hyperbolas for any $r \in \mathbb{C}$ and on the line $\mathcal{L}_5 = 0$.

The sign (a) distinguishes if the singularities are either real, or complex, or coinciding (if $a = 0$). Since $\mathcal{R}_9 = 16a$, we conclude that $\text{sign}(\mathcal{R}_9) = \text{sign}(a)$.

In the case $a \neq 0$, we could assume $a = 1$ if $a > 0$ and $a = -1$ if $a < 0$, due to a rescaling. So, we arrive at the configuration *Config. H.160* if $\mathcal{R}_9 < 0$, *Config. H.161* if $\mathcal{R}_9 > 0$ and *Config. H.162* if $\mathcal{R}_9 = 0$.

The proof of statement (B) of Theorem 5 is completed. ■

4 The configurations of invariant hyperbolas for the class $\text{QSH}_{(\eta=0)}$

In this section systems we consider systems in $\text{QSH}_{(\eta=0)}$ for which we have the following result.

Theorem 6. *Consider the class $\text{QSH}_{(\eta=0)}$ of all non-degenerate quadratic differential systems (3) possessing an invariant hyperbola and either exactly two distinct real singularities at infinity or the line at infinity filled up with singularities.*

(A) *This family is classified according to the configurations of invariant hyperbolas and of invariant straight lines of the systems, yielding 43 distinct such configurations. This geometric classification appears in DIAGRAMS 12 and 13. More precisely:*

(A₁) *There are exactly 9 configurations with an infinite number of invariant hyperbolas.*

(A₂) *The remaining 34 configurations could have up to a maximum of 2 distinct invariant hyperbolas, real or complex, and up to 3 distinct invariant straight lines, real or complex, including the line at infinity.*

(B) *DIAGRAM 14 is the bifurcation diagram in the space \mathbb{R}^{12} of the coefficients of the system in $\text{QSH}_{(\eta=0)}$ according to their configurations of invariant hyperbolas and invariant straight lines. Moreover, DIAGRAM 14 gives an algorithm to compute the configuration of a system with an invariant hyperbola for any quadratic differential system, presented in any normal form.*

Remark 12. *In the above theorem we indicate that the 43 configurations obtained for the family $\text{QSH}_{(\eta=0)}$ are distinct due to the types of ICD, ILD, MS_{0C} and PD. We defined in Section 2 such functions on the family $\text{QSH}_{(\eta=0)}$. We can read several geometrical invariants from the expressions of these cycles modulo the group action, which form a complete set of geometric invariants for the configurations of the family $\text{QSH}_{(\eta=0)}$.*

Remark 13. *The invariant polynomials which appear in DIAGRAM 2 are introduced in Section 2. Moreover, in this diagram we denote by (\mathfrak{C}_1) the following condition*

$$(\mathfrak{C}_1) : (\beta_6 = 0, \beta_{11}\mathcal{R}_{11} \neq 0) \cap ((\beta_{12} \neq 0, \gamma_{15} = 0) \cup (\beta_{12} = \gamma_{16} = 0)).$$

Remark 14. *For more details about the geometric classification of the configurations of systems in $\text{QSH}_{(\eta=0)}$ see Section 5.*

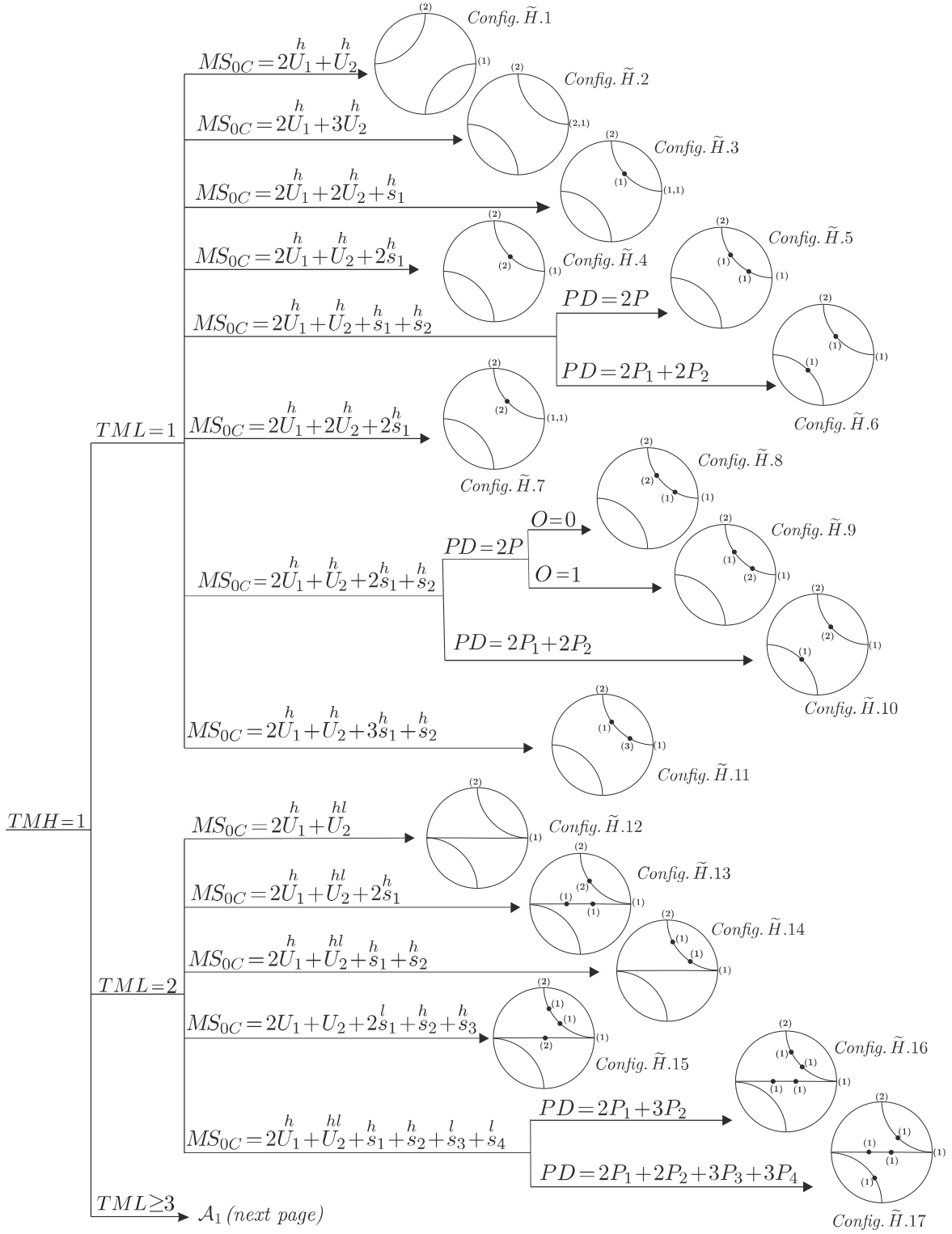

DIAGRAM 12: Diagram of configurations with one simple hyperbola

Proof: We prove part (A) under the assumption that part (B) is already proved. Later, we prove part (B). Summing up all the concepts introduced in order to define the invariants, we end up with

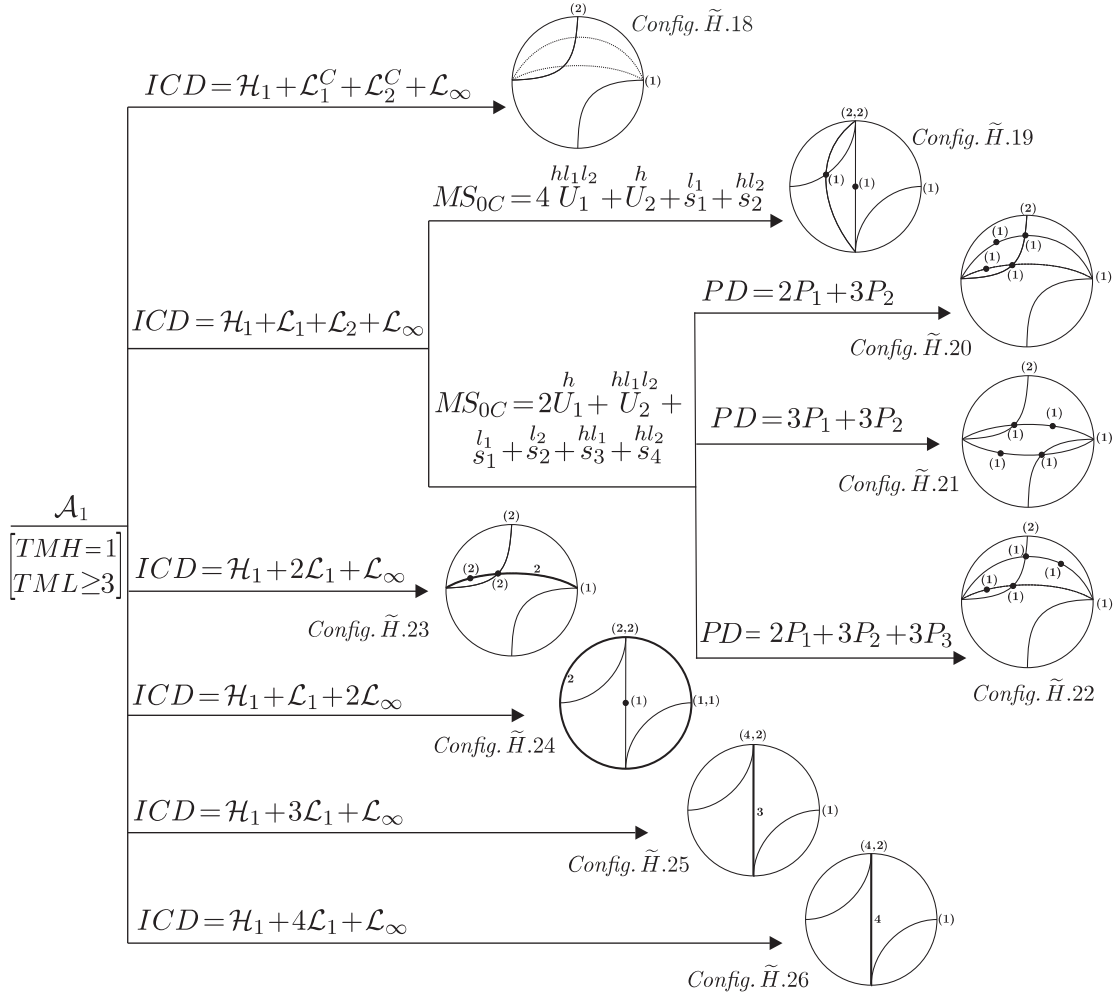

DIAGRAM 12: (Cont.) **Diagram of configurations with one simple hyperbola**

the list: ICD , ILD , MS_{0C} , TMH , TML , PD , O and $|Sing_{\infty}|$. The proof of part (A) of this theorem could be done in a similar way of the proof of part (A) of Theorem 5.

Proof of part (B). Following the conditions given by DIAGRAM 2 (the case $\eta = 0$). We consider two possibilities: $M(\tilde{a}, x, y) \neq 0$ (i.e. at infinity we have two distinct real singularities) and $M = 0 = C_2$ (when we have an infinite number of singularities at infinity).

4.1 The possibility $M(\tilde{a}, x, y) \neq 0$

According to Lemma 5 there exists a linear transformation and time rescaling which brings systems (3) to the systems

$$\frac{dx}{dt} = a + cx + dy + gx^2 + hxy, \quad \frac{dy}{dt} = b + ex + fy + (g-1)xy + hy^2. \quad (118)$$

For this systems we calculate

$$C_2(x, y) = x^2y, \quad \theta = -h^2(g-1)/2. \quad (119)$$

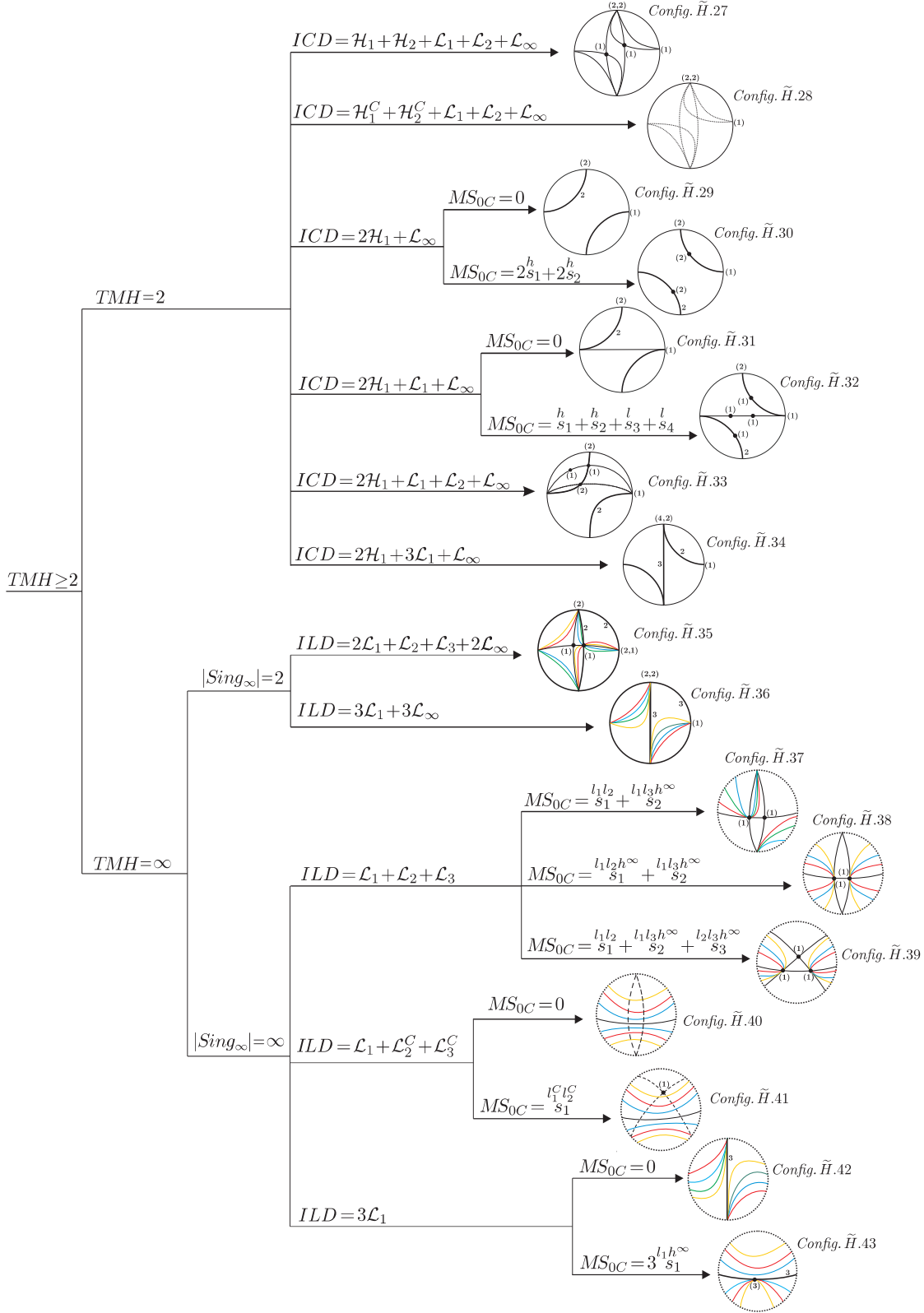

DIAGRAM 13: Diagram of configurations with $TMH \geq 2$

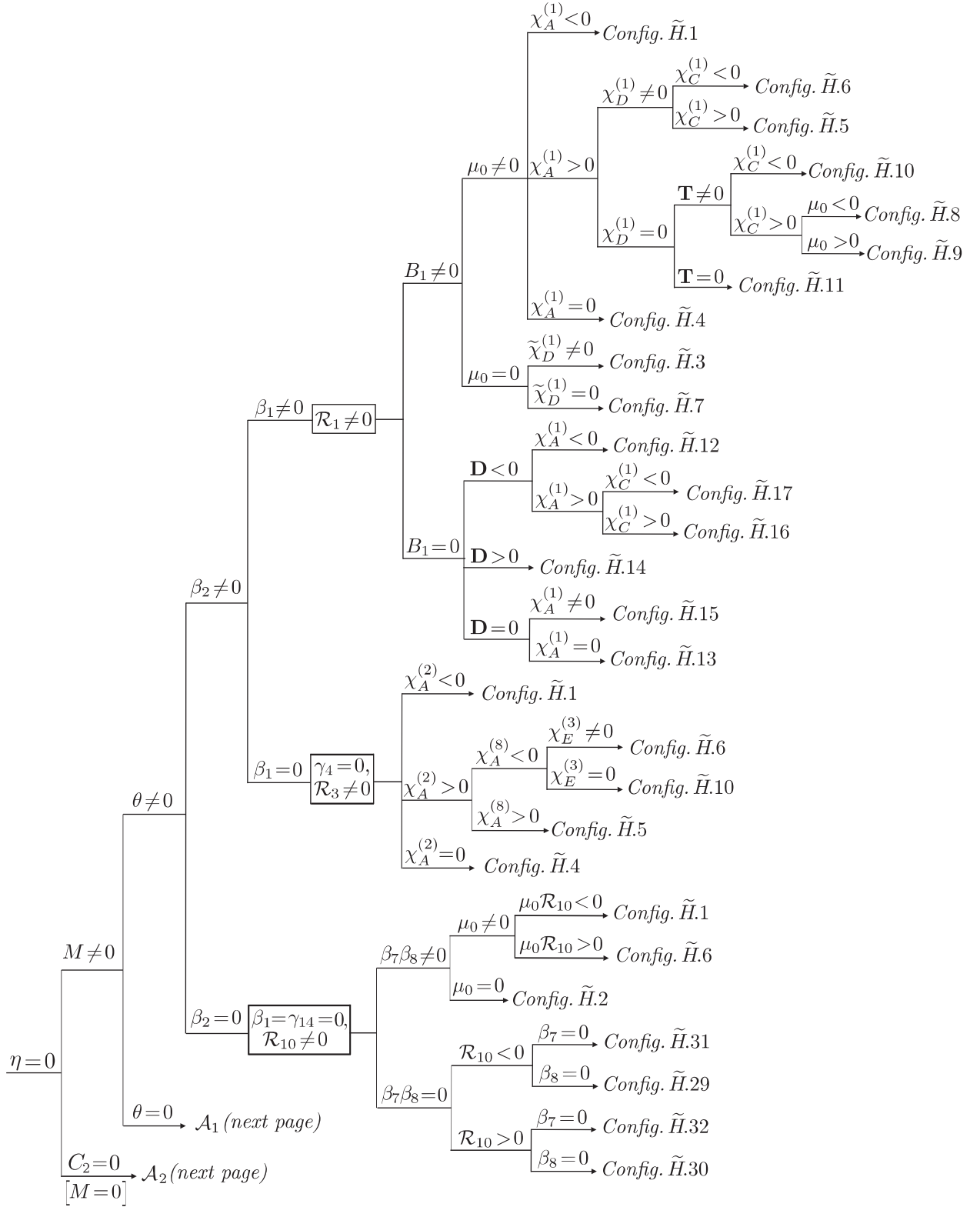

DIAGRAM 14: Bifurcation diagram in \mathbb{R}^{12} of the configurations: Case $\eta = 0$

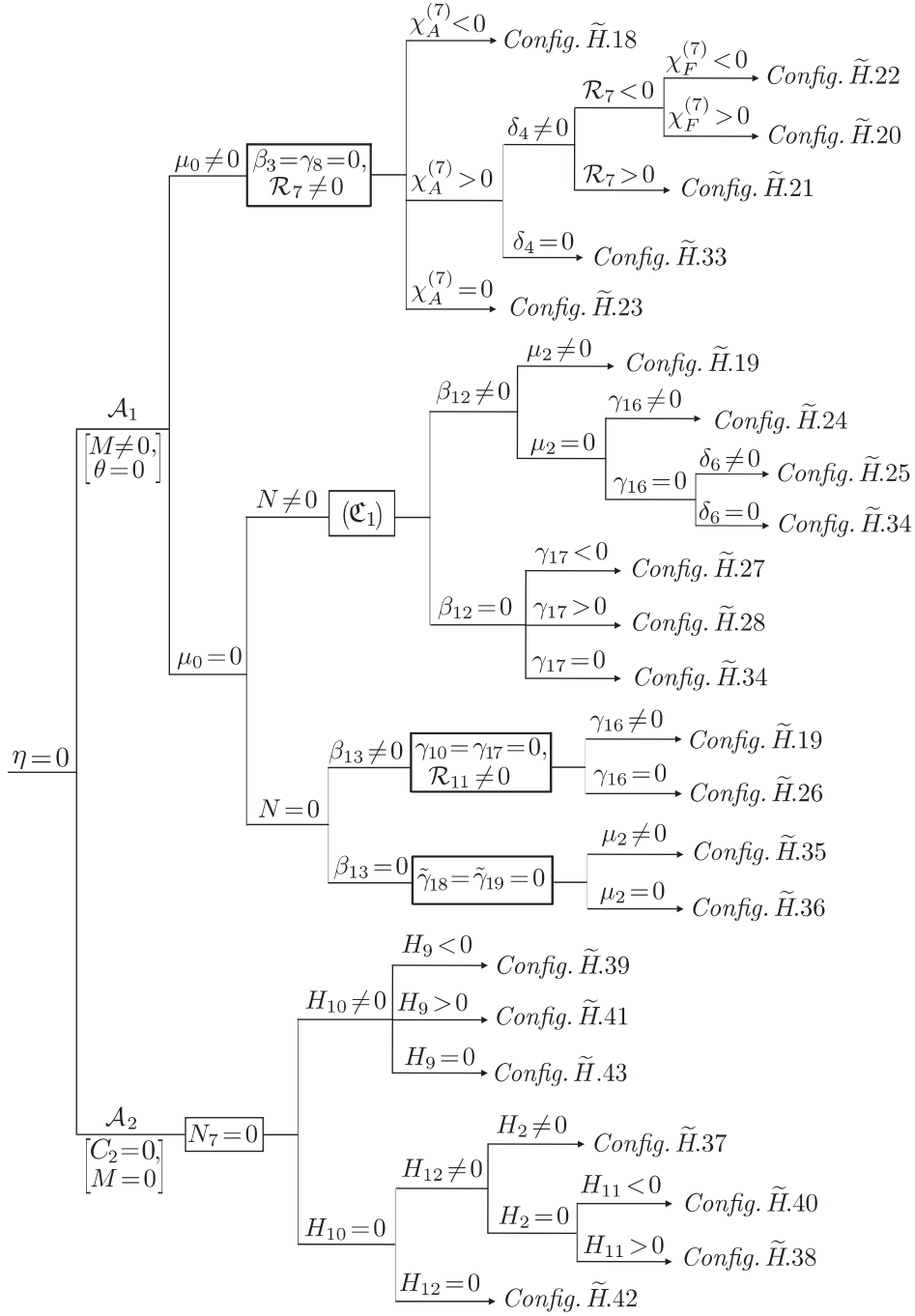

DIAGRAM 14: (*Cont.*) Bifurcation diagram in \mathbb{R}^{12} of the configurations: Case $\eta = 0$

4.1.1 The case $\theta \neq 0$

In this case $h(g-1) \neq 0$ and due to a translation we may assume $d = e = 0$. So in what follows we consider the family of systems

$$\begin{aligned} \frac{dx}{dt} &= a + cx + gx^2 + hxy, \\ \frac{dy}{dt} &= b + fy + (g-1)xy + hy^2 \end{aligned} \tag{120}$$

for which calculations yield:

$$\gamma_1 = (2c - f)(c + f)^2 h^4 (g - 1)^2 / 32, \quad \beta_2 = h^2 (2c - f) / 2.$$

According to Theorem 3 for the existence of an invariant hyperbola of the above systems the condition $\gamma_1 = 0$ is necessary. So we consider two subcases: $\beta_2 \neq 0$ and $\beta_2 = 0$.

4.1.1.1 The subcase $\beta_2 \neq 0$. Then $2c - f \neq 0$ and the condition $\gamma_1 = 0$ implies $f = -c$. Then we calculate

$$\gamma_2 = -14175c^2 h^5 (g - 1)^2 (3g - 1) [a(2g - 1) - 2bh], \quad \beta_1 = -3c^2 h^2 (g - 1)(3g - 1) / 4$$

and following DIAGRAM 2 (see Theorem 3) we examine two possibilities: $\beta_1 \neq 0$ and $\beta_1 = 0$.

4.1.1.1.1 The possibility $\beta_1 \neq 0$. Then the necessary condition $\gamma_2 = 0$ (for the existence of a hyperbola) gives $a(2g - 1) - 2bh = 0$ and setting $a = 2a_1 h$ (since $h \neq 0$) we get $b = a_1(2g - 1)$. Therefore keeping the old parameter a (instead of a_1) we arrive at the following family of systems

$$\frac{dx}{dt} = 2ah + cx + gx^2 + hxy, \quad \frac{dy}{dt} = a(2g - 1) - cy + (g - 1)xy + hy^2.$$

We observe that since $ch \neq 0$, we may assume $c = h = 1$ due to the rescaling $(x, y, t) \mapsto (cx, cy/h, t/c)$ and the additional parametrization $ah/c^2 \rightarrow a$. So we get the following 2-parameter family of systems

$$\frac{dx}{dt} = 2a + x + gx^2 + xy, \quad \frac{dy}{dt} = a(2g - 1) - y + (g - 1)xy + y^2, \quad (121)$$

which possess the following invariant hyperbola (with cofactor $(2g - 1)x + 2y$):

$$\Phi(x, y) = a + xy = 0 \quad (122)$$

and for which the following coefficient conditions (defined by $\theta\beta_2\beta_1\mathcal{R}_1 \neq 0$) must be satisfied:

$$a(g - 1)(3g - 1) \neq 0. \quad (123)$$

For systems (121) we calculate

$$B_1 = 4a^3(g - 1)^2(1 - 2g). \quad (124)$$

1) The case $B_1 \neq 0$. In this case by Lemma 2 we have no invariant lines. For systems (121) we calculate $\mu_0 = g$ and we consider two subcases: $\mu_0 \neq 0$ and $\mu_0 = 0$.

a) The subcase $\mu_0 \neq 0$. Then by Lemma 1 the systems have finite singularities of total multiplicity four. More exactly, systems (121) possess the singular points $M_{1,2}(x_{1,2}, y_{1,2})$ and $M_{3,4}(x_{3,4}, y_{3,4})$, where

$$x_{1,2} = \frac{-1 \pm \sqrt{1 - 4ag}}{2g}, \quad y_{1,2} = \frac{1 \pm \sqrt{1 - 4ag}}{2},$$

$$x_{3,4} = -1 \pm \sqrt{1 - 4a}, \quad y_{3,4} = (2g - 1)(1 \mp \sqrt{1 - 4a}) / 2.$$

We detect that the singularities $M_{1,2}(x_{1,2}, y_{1,2})$ are located on the hyperbola. On the other hand for systems (121) we calculate the invariant polynomials

$$\chi_A^{(1)} = 9(g - 1)^2(3g - 1)^2(1 - 4ag) / 64$$

and by (123) we conclude that $\text{sign}(\chi_A^{(1)}) = \text{sign}(1 - 4ag)$ (if $1 - 4ag \neq 0$) and we consider three possibilities: $\chi_A^{(1)} < 0$, $\chi_A^{(1)} > 0$ and $\chi_A^{(1)} = 0$.

α_1) The possibility $\chi_A^{(1)} < 0$. So we have no real singularities located on the invariant hyperbola and we arrive at the configurations of invariant curves given by *Config. $\tilde{H}.1$* .

α_2) The possibility $\chi_A^{(1)} > 0$. In this case the singularities $M_{1,2}(x_{1,2}, y_{1,2})$ located on the hyperbola are real and we have the next result.

Lemma 8. *Assume that the singularities $M_{1,2}(x_{1,2}, y_{1,2})$ (located on the hyperbola) are finite. Then these singularities are located on different branches of the hyperbola if $\chi_C^{(1)} < 0$ and they are located on the same branch if $\chi_C^{(1)} > 0$, where $\chi_C^{(1)} = 315ag(g-1)^4(3g-1)^2/32$.*

Proof: Since the asymptotes of the hyperbola (122) are the lines $x = 0$ and $y = 0$ it is clear that the singularities $M_{1,2}$ are located on different branches of the hyperbola if and only if $x_1x_2 < 0$. We calculate

$$x_1x_2 = \left[\frac{-1 + \sqrt{1 - 4ag}}{2g} \right] \left[\frac{-1 - \sqrt{1 - 4ag}}{2g} \right] = \frac{a}{g} \quad (125)$$

and due to the condition (123) we obtain that $\text{sign}(x_1x_2) = \text{sign}(\chi_C^{(1)})$. This completes the proof of the lemma. ■

Other two singular points $M_{3,4}(x_{3,4}, y_{3,4})$ of systems (121) are generically located outside the hyperbola. We need to determine the conditions when some singular points of the system become singular points lying on the hyperbola. Considering (122) we calculate

$$\Phi(x, y)|_{\{x=x_{3,4}, y=y_{3,4}\}} = (2g - 1)(-1 \pm \sqrt{1 - 4a}) + a(4g - 1) \equiv \Omega_{\pm}(a, g).$$

Put $\Omega_3(a, g) = \Omega_+(a, g)$ and $\Omega_4(a, g) = \Omega_-(a, g)$. It is clear that at least one of the singular points $M_3(x_3, y_3)$ or $M_4(x_4, y_4)$ belongs to the hyperbola (122) if and only if

$$\Omega_3\Omega_4 = a[2(1 - 2g) + a(1 - 4g)^2] \equiv aZ_1 = 0.$$

On the other hand for systems (121) we have $\tilde{\chi}_D^{(1)} = 54Z_1$ and clearly due to (123) the condition $\tilde{\chi}_D^{(1)} = 0$ is equivalent to $Z_1 = 0$. We examine two cases: $\tilde{\chi}_D^{(1)} \neq 0$ and $\tilde{\chi}_D^{(1)} = 0$.

α) The case $\tilde{\chi}_D^{(1)} \neq 0$. Then $Z_1 \neq 0$ and on the hyperbola there are two simple real singularities (namely $M_{1,2}(x_{1,2}, y_{1,2})$). By Lemma 8 their position is defined by the invariant polynomial $\chi_C^{(1)}$ and we arrive at the configuration given by *Config. $\tilde{H}.6$* if $\chi_C^{(1)} < 0$ and by *Config. $\tilde{H}.5$* if $\chi_C^{(1)} > 0$.

β) The case $\tilde{\chi}_D^{(1)} = 0$. In this case the condition $Z_1 = 0$ implies $4g - 1 \neq 0$ (otherwise for $g = 1/4$ we get $Z_1 = 1 \neq 0$). So we obtain $a = 2(2g - 1)/(4g - 1)^2$. In this case the coordinates of the finite singularities $M_i(x_i, y_i)$ ($i=1,2,3,4$) are as follows

$$x_1 = \frac{1 - 2g}{g(4g - 1)}, \quad y_1 = \frac{2g}{4g - 1}; \quad x_2 = x_3 = \frac{2}{1 - 4g}, \quad y_2 = y_3 = \frac{2g - 1}{4g - 1};$$

$$x_4 = \frac{4(1 - 2g)}{(4g - 1)}, \quad y_4 = \frac{2(g - 1)^2}{4g - 1},$$

i.e. all the singularities are real. Then considering Proposition 1 we calculate

$$\mathbf{D} = 0, \quad \mathbf{T} = -3[2g(g-1)x + (2g-1)y]^2 \mathbf{P},$$

$$\mathbf{P} = \frac{(4g-3)^2(gx-y)^2(2gx-x+2y)^2}{(4g-1)^4}.$$

β_1) *The subcase $\mathbf{T} \neq 0$.* Then $\mathbf{T} < 0$ and according to Proposition 1 systems (121) possess one double and two simple real finite singularities. As it is mentioned above, the singular point $M_3(x_3, y_3)$ coalesces with the singular point $M_2(x_2, y_2)$ located on the hyperbola, whereas $M_4(x_4, y_4)$ remains outside the hyperbola.

Considering the coordinates of the singular points we calculate

$$\text{sign}(x_1 x_2) = \text{sign}(g(2g-1)), \quad \chi_C^{(1)} = \frac{315g(2g-1)(g-1)^4(3g-1)^2}{16(4g-1)^2}.$$

Therefore in the case $\chi_C^{(1)} < 0$ the singular points M_1 and $M_2 = M_3$ are located on different branches of the hyperbola and we arrive at the configuration *Config. \tilde{H} .10*.

Assume now that the condition $\chi_C^{(1)} > 0$ holds, i.e. the two singular points (one double and one simple) are located on the same branch of the hyperbola. Since on this branch are also located two infinite singular points (one double and one simple), it is clear that the reciprocal position of singular points M_1 and M_2 (double) on the branch leads to different configurations. So we need to determine the conditions to distinguish these two situations.

We calculate

$$x_1 - x_2 = \frac{1-2g}{g(4g-1)} - \frac{2}{1-4g} = \frac{1}{g(4g-1)}$$

and hence the reciprocal position of M_1 and M_2 depends on the sign of the expression $g(4g-1)$. On the other hand, the condition $\chi_C^{(1)} > 0$ implies $g(2g-1) > 0$, i.e. we have either $g < 0$ or $g > 1/2$. Since $\mu_0 = g$ we deduce that these two possibilities are governed by the invariant polynomial μ_0 .

It is easy to detect that we arrive at *Config. \tilde{H} .8* if $\mu_0 < 0$ (i.e. $g < 0$) and we get *Config. \tilde{H} .9* if $\mu_0 > 0$ (i.e. $g > 1/2$).

β_2) *The subcase $\mathbf{T} = 0$.* In this case due to the condition $B_1 \neq 0$ (i.e. $2g-1 \neq 0$) the equality $\mathbf{T} = 0$ holds if and only if $\mathbf{P} = 0$ which is equivalent to $4g-3=0$, i.e. $g=3/4$. In this case we obtain

$$\mathbf{D} = \mathbf{T} = \mathbf{P} = 0, \quad \mathbf{R} = 3(3x-4y)^2/64$$

and since $\mathbf{R} \neq 0$, by Proposition 1 we obtain one triple and one simple singularities. More precisely the singular points M_2, M_3 and M_4 coalesce and since all the parameters of systems (121) are fixed we get the unique configuration given by *Config. \tilde{H} .11*.

α_3) *The possibility $\chi_A^{(1)} = 0$.* In this case we get $g = 1/(4a)$ and the singularities $M_{1,2}(x_{1,2}, y_{1,2})$ located on the hyperbola coincide. On the other hand we have $Z_1 = a \neq 0$ and hence none of the singular points $M_{3,4}$ could belong to the hyperbola. So we arrive at the unique configuration presented by *Config. \tilde{H} .4*.

b) *The subcase $\mu_0 = 0$.* Then we have $\mu_1 = -y$ and by Lemma 1 one finite singular point has gone to infinity and coalesced with the infinite singular point $[1, 0, 0]$. In this case we arrive at the

1-parameter family of systems

$$\frac{dx}{dt} = 2a + x + xy, \quad \frac{dy}{dt} = -a - y - xy + y^2 \quad (126)$$

possessing the singular points $M'_1(x'_1, y'_1)$ and $M_{2,3}(x_{2,3}, y_{2,3})$ (the same points for the particular case $g = 0$) with the coordinates

$$x'_1 = -a, \quad y'_1 = 1; \quad x_{3,4} = -1 \pm \sqrt{1 - 4a}, \quad y_{3,4} = (-1 \pm \sqrt{1 - 4a})/2.$$

We observe that only the singular point M'_1 is located on the hyperbola. On the other hand it was shown earlier that one of the points $M_{2,3}(x_{2,3}, y_{2,3})$ belongs to the hyperbola if and only if $Z_1 = 0$ which in this case gets the value $Z_1 = a + 2$. For systems (126) we calculate

$$\tilde{\chi}_D^{(1)} = 54(a + 2)$$

and it is not too difficult to detect that in the case $\tilde{\chi}_D^{(1)} \neq 0$ (i.e. $a + 2 \neq 0$) we arrive at the unique configuration given by *Config. $\tilde{H}.3$* .

Assume now $\tilde{\chi}_D^{(1)} = 0$. Then $a = -2$ and we get a system with constant coefficients for which the singular point M_2 has coalesced with M'_1 . As a result we obtain *Config. $\tilde{H}.7$* .

2) The case $B_1 = 0$. Considering (124) and the condition (123) this implies $g = 1/2$ and we obtain the following 1-parameter family of systems

$$\frac{dx}{dt} = 2a + x + x^2/2 + xy, \quad \frac{dy}{dt} = -y(1 + x/2 - y). \quad (127)$$

These systems besides the hyperbola (122) possess the invariant line $y = 0$ and four singular points $M_i(x_i, y_i)$ with the coordinates

$$x_{1,2} = -1 \pm \sqrt{1 - 2a}, \quad y_{1,2} = \frac{1 \pm \sqrt{1 - 2a}}{2}, \\ x_{3,4} = -1 \pm \sqrt{1 - 4a}, \quad y_{3,4} = 0.$$

We observe that the singular point M_1 and M_2 are located on the hyperbola, whereas M_3 and M_4 are situated on the invariant line $y = 0$, which is one of the asymptotes of the hyperbola (122). For the above systems we calculate

$$\mathbf{D} = 48a^2(1 - 2a)(4a - 1), \quad \chi_A^{(1)} = 9(1 - 2a)/1024$$

and it is clear that due to the condition (123) (i.e. $a \neq 0$) two of the finite singular point could coalesce if and only if $\mathbf{D} = 0$. So we examine three subcases: $\mathbf{D} < 0$, $\mathbf{D} > 0$ and $\mathbf{D} = 0$.

a) The subcase $\mathbf{D} < 0$. Then $(1 - 2a)(4a - 1) < 0$ and we observe that if $\chi_A^{(1)} < 0$ (i.e. $a > 1/2$) all the singular points are complex and we get the unique configuration given by *Config. $\tilde{H}.12$* .

Assume now $\chi_A^{(1)} > 0$ (i.e. $a < 1/2$). Then the condition $\mathbf{D} < 0$ implies $a < 1/4$ and all singular points are real. We calculate $x_1x_2 = 2a$ and $\chi_C^{(1)} = 316a/4096$ and hence this invariant polynomials governs the position of the singular points located on the hyperbola (on the same branch or not). Thus we get *Config. $\tilde{H}.17$* when $\chi_C^{(1)} < 0$ and *Config. $\tilde{H}.16$* when $\chi_C^{(1)} > 0$.

b) *The subcase $\mathbf{D} > 0$.* In this case we have $1/4 < a < 1/2$ and therefore the singular points located on the hyperbola are real, whereas the singularities from the invariant line are complex. As $a > 0$ we deduce that the real singularities are located on the same branch of the hyperbola. As a result, we get the unique configuration *Config. \tilde{H} .14*.

c) *The subcase $\mathbf{D} = 0$.* Then either $a = 1/4$ or $a = 1/2$ and these possibilities are distinguished by $\chi_A^{(1)}$. Therefore we get the configuration *Config. \tilde{H} .15* if $\chi_A^{(1)} \neq 0$ and *Config. \tilde{H} .13* if $\chi_A^{(1)} = 0$.

4.1.1.1.2 The possibility $\beta_1 = 0$. Then due to $\theta \neq 0$ (i.e. $h(g-1) \neq 0$) and to the condition $\beta_2 = 3ch^2/2 \neq 0$, the condition $\beta_1 = 0$ implies $g = 1/3$ and $\gamma_2 = 0$. So we arrive at the following family of systems

$$\frac{dx}{dt} = a + cx + x^2/3 + hxy, \quad \frac{dy}{dt} = b - cy - 2xy/3 + hy^2.$$

We observe that since $ch \neq 0$ we may assume $c = h = 1$ due to the rescaling $(x, y, t) \mapsto (cx, cy/h, t/c)$. According to Theorem 3 (see DIAGRAM 2) the above systems possess an invariant hyperbola if and only if $\gamma_4 = 0$ and $\mathcal{R}_3 \neq 0$. Considering the condition $c = h = 1$ for these systems we calculate

$$\gamma_4 = 16(a + 6b)^2/3, \quad \mathcal{R}_3 = 3b/2$$

and hence the condition $\gamma_4 = 0$ gives $b = -a/6 \neq 0$. So we get the following 1-parameter family of systems

$$\frac{dx}{dt} = a + x + x^2/3 + xy, \quad \frac{dy}{dt} = -a/6 - y - 2xy/3 + y^2 \quad (128)$$

with $a \neq 0$ which possess the following invariant hyperbola

$$\Phi(x, y) = a + 2xy = 0 \quad (129)$$

and singular points $M_i(x_i, y_i)$ ($i=1,2,3,4$) with the coordinates

$$\begin{aligned} x_{1,2} &= (-3 \pm \sqrt{3(3-2a)})/2, & y_{1,2} &= (3 \pm \sqrt{3(3-2a)})/6, \\ x_{3,4} &= -1 \pm \sqrt{1-2a}, & y_{3,4} &= (-1 \pm \sqrt{1-2a})/6. \end{aligned}$$

We observe that the singularities $M_{1,2}(x_{1,2}, y_{1,2})$ are located on the hyperbola and since $\chi_A^{(2)} = 2(3-2a)/9$ we deduce that these points are complex (respectively, real) if $\chi_A^{(2)} < 0$ (respectively $\chi_A^{(2)} > 0$) and they coincide if $\chi_A^{(2)} = 0$.

On the other hand we have $x_1x_2 = 3a/2$ and $\chi_A^{(8)} = 23a/12$ and therefore we conclude that the singular points $M_{1,2}$ are located on different branches of the hyperbola if $\chi_A^{(8)} < 0$ and on the same branch if $\chi_A^{(8)} > 0$.

Other two singular points $M_{3,4}(x_{3,4}, y_{3,4})$ of systems (128) generically are located outside the hyperbola. In order to determine the conditions when at least one of these singular points is located on the hyperbola we calculate

$$\begin{aligned} \Phi(x, y)|_{\{x=x_{3,4}, y=y_{3,4}\}} &= (a + 2 \mp 2\sqrt{1-2a})/3 \equiv \Omega_{3,4}(a), \\ \Omega_3\Omega_4 &= a(12+a)/9, \quad \chi_E^{(3)} = -9a(12+a)/8. \end{aligned}$$

It is clear that at least one of the singular points M_3 or M_4 belongs to the hyperbola (129) if and only if $\chi_E^{(3)} = 0$.

Since for systems (128) we have $B_1 = 2a^3/27 \neq 0$ and $\mu_0 = 1/3 \neq 0$, by Lemmas 1 and 2 we have no invariant lines and none of the finite singularities could go to infinity. So we arrive at the following conditions and configurations:

- $\chi_A^{(2)} < 0 \Rightarrow \text{Config. } \tilde{H}.1;$
- $\chi_A^{(2)} > 0, \chi_A^{(8)} < 0 \text{ and } \chi_E^{(3)} \neq 0 \Rightarrow \text{Config. } \tilde{H}.6;$
- $\chi_A^{(2)} > 0, \chi_A^{(8)} < 0 \text{ and } \chi_E^{(3)} = 0 \Rightarrow \text{Config. } \tilde{H}.10;$
- $\chi_A^{(2)} > 0 \text{ and } \chi_A^{(8)} > 0 \Rightarrow \text{Config. } \tilde{H}.5;$
- $\chi_A^{(2)} = 0 \Rightarrow \text{Config. } \tilde{H}.4.$

4.1.1.2 The subcase $\beta_2 = 0$. Then $f = 2c$ and this implies $\gamma_1 = 0$. By Theorem 3 (see DIAGRAM 2) in this case we have an invariant hyperbola if and only if $\gamma_2 = \beta_1 = \gamma_{14} = 0$ and $\mathcal{R}_{10} \neq 0$. Moreover, this hyperbola is simple if $\beta_7\beta_8 \neq 0$ and it is double if $\beta_7\beta_8 = 0$. So we calculate

$$\gamma_2 = -14175ac^2h^5(g-1)^3(1+3g), \quad \beta_1 = -9c^2(g-1)^2h^2/16$$

and evidently the condition $\gamma_2 = \beta_1 = 0$ implies $c = 0$. Then we obtain

$$\gamma_{14} = -80h^3[a(2g-1) - 2bh], \quad \mathcal{R}_{10} = -4ah^2 \neq 0$$

and as $h \neq 0$ the condition $\gamma_{14} = 0$ gives $a(2g-1) - 2bh = 0$. Then setting $a = 2a_1h$ we get $b = a_1(2g-1)$ and keeping the old parameter a (instead of a_1) after the additional rescaling $y \rightarrow y/h$ we arrive and at the following 2-parameter family of systems

$$\frac{dx}{dt} = 2a + gx^2 + xy, \quad \frac{dy}{dt} = a(2g-1) + (g-1)xy + y^2. \quad (130)$$

These systems possess the invariant hyperbola (122) and we calculate

$$\beta_7 = 8(1-2g), \quad \beta_8 = 32(1-4g), \quad B_1 = 4a^3(g-1)^2(1-2g), \quad \mu_0 = g$$

and following DIAGRAM 2 (see Theorem 3) we examine two possibilities: $\beta_7\beta_8 \neq 0$ and $\beta_7\beta_8 = 0$.

4.1.1.2.1 The possibility $\beta_7\beta_8 \neq 0$. In this case for systems (130) the condition

$$a(g-1)(2g-1)(4g-1) \neq 0 \quad (131)$$

is satisfied and this implies $B_1 \neq 0$. Therefore according to Lemma 2 these systems could not have invariant lines and as earlier we consider two cases: $\mu_0 \neq 0$ and $\mu_0 = 0$.

1) The case $\mu_0 \neq 0$. Then systems (130) possess four finite singular points $M_i(x_i, y_i)$ ($i=1,2,3,4$) with the coordinates

$$\begin{aligned} x_{1,2} &= \pm\sqrt{-a/g}, & y_{1,2} &= \pm\sqrt{-ag}, \\ x_{3,4} &= \pm 2\sqrt{-a}, & y_{3,4} &= \pm\sqrt{-a}(1-2g). \end{aligned}$$

We detect that the singularities $M_{1,2}(x_{1,2}, y_{1,2})$ are located on the hyperbola and they are complex (respectively, real) if $ag > 0$ (respectively $ag < 0$). Moreover since $x_1x_2 = a/g$ then in the case when they are real (i.e. $ag < 0$) these points are located on different branches of the hyperbola (122).

On the other hand considering singular points $M_{3,4}(x_{3,4}, y_{3,4})$ we calculate

$$\Phi(x, y)|_{\{x=x_3, y=y_3\}} = \Phi(x, y)|_{\{x=x_4, y=y_4\}} = a(4g - 1) \neq 0,$$

i.e. for any values of the parameters a and g satisfying the condition (131) these singularities could not belong to the hyperbola (122).

For systems (130) we calculate $\mu_0\mathcal{R}_{10} = -8ag \neq 0$ and hence $\text{sign}(\mu_0\mathcal{R}_{10}) = -\text{sign}(ag)$. So we arrive at the configuration given by *Config. $\tilde{H}.1$* if $\mu_0\mathcal{R}_{10} < 0$ and by *Config. $\tilde{H}.6$* if $\mu_0\mathcal{R}_{10} > 0$.

2) *The case $\mu_0 = 0$.* Then $g = 0$ and we calculate

$$\mu_0 = \mu_1 = 0, \quad \mu_2 = ay^2 \neq 0$$

and by Lemma 1 two finite singular points have gone to infinity and both coalesced with the infinite singular point $[1, 0, 0]$. As a result we get the unique configuration *Config. $\tilde{H}.2$* .

4.1.1.2.2 The possibility $\beta_7\beta_8 = 0$. Assume first $\beta_7 = 0$, i.e. $g = 1/2$ which implies $B_1 = 0$ and systems (130) possess the invariant line $y = 0$. Since $\mathcal{R}_{10} = -8a$, considering the coordinates of the singularities we arrive at *Config. $\tilde{H}.31$* if $\mathcal{R}_{10} < 0$ and at *Config. $\tilde{H}.32$* if $\mathcal{R}_{10} > 0$.

Suppose now $\beta_8 = 0$ which gives $g = 1/4$. Then the singularities M_3 and M_4 coalesce with M_1 and M_2 , respectively. So in this case systems (130) have two double singular points located on the hyperbola which are complex if $a > 0$ and real if $a < 0$. So we obtain *Config. $\tilde{H}.29$* if $\mathcal{R}_{10} < 0$ and *Config. $\tilde{H}.30$* if $\mathcal{R}_{10} > 0$.

4.1.2 The case $\theta = 0$

According to (119) we get $h(g - 1) = 0$ and since for systems (118) we have $\mu_0 = gh^2$ we consider two subcases: $\mu_0 \neq 0$ and $\mu_0 = 0$.

4.1.2.1 The subcase $\mu_0 \neq 0$. Then $h \neq 0$ and the condition $\theta = 0$ yields $g = 1$. Since $h \neq 0$ via the affine transformation

$$x_1 = x + d/h, \quad y_1 = hy + c - 2d/h$$

we may assume $d = f = 0$, $h = 1$ and systems (118) become as systems

$$\frac{dx}{dt} = a + cx + x^2 + xy, \quad \frac{dy}{dt} = b + ex + y^2 \tag{132}$$

for which we calculate

$$N = 9y^2, \quad \beta_4 = 2, \quad \beta_3 = -e/4, \quad \gamma_1 = 9ce^2/16.$$

Since $N\beta_4 \neq 0$ following DIAGRAM 2 (see Theorem 3) for the existence of an invariant hyperbola the conditions $\gamma_1 = \gamma_2 = \beta_3 = 0$ are necessary. Therefore we have $e = 0$ and this implies $\gamma_1 = \gamma_2 = 0$ and

$$\gamma_8 = 42(9a - 18b - 2c^2)^2.$$

So setting for simplicity $c = 3c_1$ and $a = 2a_1$ the condition $\gamma_8 = 0$ yields $b = a_1 - c_1^2$ and keeping the notation for the parameters c and a we arrive at the 2-parameter family of systems

$$\frac{dx}{dt} = 2a + 3cx + x^2 + xy, \quad \frac{dy}{dt} = a - c^2 + y^2. \quad (133)$$

These systems possess the following invariant hyperbola and two invariant lines:

$$\Phi(x, y) = a + cx + xy = 0, \quad L_{1,2} = y \pm \sqrt{c^2 - a} = 0 \quad (134)$$

and singular points $M_i(x_i, y_i)$ ($i=1,2,3,4$) with the coordinates

$$\begin{aligned} x_{1,2} &= -c \pm \sqrt{c^2 - a}, & y_{1,2} &= \pm \sqrt{c^2 - a}, \\ x_{3,4} &= -2(c \pm \sqrt{c^2 - a}), & y_{3,4} &= \pm \sqrt{c^2 - a}. \end{aligned}$$

The singularities $M_{1,2}(x_{1,2}, y_{1,2})$ are located at the intersection points of the hyperbola with invariant lines, whereas the singularities $M_{3,4}$ are located only on the invariant lines. More precisely, the singular point M_3 (respectively, M_4) is located on the same invariant line as the singularity M_1 (respectively, M_2). Since $\chi_A^{(7)} = (c^2 - a)/4$ we deduce that all these finite singular points as well as the invariant lines $L_{1,2}$ are complex if $\chi_A^{(7)} < 0$ and real if $\chi_A^{(7)} > 0$. In the case $\chi_A^{(7)} = 0$ (then $a = c^2 \neq 0$) we obtain that the singular point M_1 (respectively, M_3) coincides with M_2 (respectively, M_4) and moreover, in this case invariant lines coincide, too. So we consider three possibilities: $\chi_A^{(7)} < 0$, $\chi_A^{(7)} > 0$ and $\chi_A^{(7)} = 0$.

4.1.2.1.1 The possibility $\chi_A^{(7)} < 0$. Then $c^2 - a < 0$ (this implies $a > 0$) and all the singularities and the invariant lines are complex. As a result we arrive at the unique configuration given by *Config. \tilde{H} .18*.

4.1.2.1.2 The possibility $\chi_A^{(7)} > 0$. In this case the finite singularities $M_1 \neq M_2$ and $M_3 \neq M_4$ are real and we observe that the singular points $M_{3,4}$ of systems (133) generically are located outside the hyperbola. We calculate

$$\Phi(x, y)|_{\{x=x_{3,4}, y=y_{3,4}\}} = 3a + 4c(-c \pm 2\sqrt{c^2 - a}) \equiv \Omega_{3,4}(a, c), \quad \Omega_3\Omega_4 = a(9a - 8c^2).$$

On the other hand by Theorem 3 (see DIAGRAM 2) the hyperbola (134) is simple if $\delta_4 = 3(9a - 8c^2) \neq 0$ and it is double if $\delta_4 = 0$. So we conclude that at least one of the singularities $M_{3,4}$ belongs to the hyperbola if and only if the hyperbola is double (i.e. when $\delta_4 = 0$). So we consider two cases: $\delta_4 \neq 0$ and $\delta_4 = 0$.

1) The case $\delta_4 \neq 0$. Then all four finite singularities are real and distinct. In this case in order to detect the different configurations we need to distinguish the position of the branches of the hyperbola (which depends on the sign of the parameter a) as well as the position of the singular point M_3 on the line $y = \sqrt{c^2 - a}$ with respect to M_1 and the position of M_4 on the line $y = -\sqrt{c^2 - a}$ with respect to M_2 . So considering the coordinates of the finite singularities we calculate

$$x_1x_2 = a, \quad (x_1 - x_3)(x_2 - x_4) = 9a - 8c^2, \quad \mathcal{R}_7 = -3a/4, \quad \chi_F^{(7)} = 9a - 8c^2.$$

So the singularities M_1 and M_2 are located on the same branch of the hyperbola if $\mathcal{R}_7 < 0$ and on different branches if $\mathcal{R}_7 > 0$. To determine exactly the position of M_1 and M_3 as well as of M_2 and M_4 we observe, that due to the rescaling $(x, y, t) \mapsto (-x, -y, -t)$ we may assume that the parameter $c \geq 0$. This means that $x_1 - x_3 = c + 3\sqrt{c^2 - a} > 0$ (due to $c \geq 0$ and $c^2 - a > 0$) and hence the sign of $x_2 - x_4$ is governed by the invariant polynomial $\chi_F^{(7)}$.

Thus in the case $\chi_A^{(7)} > 0$ and $\delta_4 \neq 0$ (then $\chi_F^{(7)} \neq 0$) we arrive at the following conditions and configurations:

- $\mathcal{R}_7 < 0$ and $\chi_F^{(7)} < 0 \Rightarrow \text{Config. } \tilde{H}.22;$
- $\mathcal{R}_7 < 0$ and $\chi_F^{(7)} > 0 \Rightarrow \text{Config. } \tilde{H}.20;$
- $\mathcal{R}_7 > 0 \Rightarrow \text{Config. } \tilde{H}.21.$

2) The case $\delta_4 = 0$. Then $a = 8c^2/9 \neq 0$ and by Theorem 3 (see DIAGRAM 2) the hyperbola (134) is double. Moreover in this case the singular point M_4 coincides with M_2 , located on the hyperbola. Since $c \neq 0$ (i.e. no other singularities could coincide) we get the unique configuration *Config. $\tilde{H}.33$* .

4.1.2.1.3 The possibility $\chi_A^{(7)} = 0$. Then $a = c^2 \neq 0$ and this implies the coalescence of the singularity M_2 with M_1 and of M_4 with M_3 . Clearly in this case we get the double invariant line $y = 0$ and since $c \neq 0$ we obtain *Config. $\tilde{H}.23$* .

4.1.2.2 The subcase $\mu_0 = 0$. Then the condition $\theta = \mu_0 = 0$ gives $h = 0$ and for systems (118) in this case we calculate

$$N = 9(g-1)(1+g)x^2, \quad \gamma_1 = \gamma_2 = \beta_4 = 0, \quad \beta_6 = d(g-1)(1+g)/4.$$

We next consider two possibilities: $N \neq 0$ and $N = 0$.

4.1.2.2.1 The possibility $N \neq 0$. In this case by Theorem 3 (see DIAGRAM 2) for the existence of at least one hyperbola the condition (\mathfrak{C}_1) are necessary and sufficient, where

$$(\mathfrak{C}_1) : (\beta_6 = 0, \beta_{11}\mathcal{R}_{11} \neq 0) \cap ((\beta_{12} \neq 0, \gamma_{15} = 0) \cup (\beta_{12} = \gamma_{16} = 0)).$$

So the condition $\beta_6 = 0$ is necessary. Since $N \neq 0$ we get $d = 0$ and moreover as $g - 1 \neq 0$, due a translation, we may assume $e = f = 0$. Therefore we arrive at the family of systems

$$\frac{dx}{dt} = a + cx + gx^2, \quad \frac{dy}{dt} = b + (g-1)xy,$$

for which following DIAGRAM 2 we calculate:

$$\begin{aligned} \beta_{11} &= 4(2g-1)x^2, & \mathcal{R}_{11} &= -3b(g-1)^2x^4, & \beta_{12} &= (3g-1)x, \\ \gamma_{15} &= 4(g-1)^2(3g-1)[a(3g-1)^2 + c^2(1-2g)]x^5. \end{aligned}$$

So according to Theorem 3 the condition $\beta_{11}\mathcal{R}_{11} \neq 0$ is necessary for the existence of a hyperbola and considering DIAGRAM 2 we have to consider the two cases: $\beta_{12} \neq 0$ and $\beta_{12} = 0$.

1) *The case $\beta_{12} \neq 0$.* By Theorem 3 in this case there exists one hyperbola if and only if $\gamma_{15} = 0$. We observe that due to $b \neq 0$ (since $\mathcal{R}_{11} \neq 0$) we may assume $b = 1$ due to the rescaling $(x, y, t) \mapsto (bx, y, t/b)$. Since $3g - 1 \neq 0$, setting $c = (3g - 1)c_1$ the condition $\gamma_{15} = 0$ yields $a = c_1^2(2g - 1)$ and renaming the parameter c_1 as c again we arrive at the 2-parameter family of systems

$$\frac{dx}{dt} = (c + x)[c(2g - 1) + gx], \quad \frac{dy}{dt} = 1 + (g - 1)xy \quad (135)$$

for which the condition $N\beta_{11}\beta_{12}\mathcal{R}_{11}$ implies

$$(g - 1)(g + 1)(2g - 1)(3g - 1) \neq 0. \quad (136)$$

These systems possess the following invariant hyperbola and invariant lines:

$$\Phi(x, y) = \frac{1}{2g - 1} + cy + xy = 0, \quad L_1 = gx + c(2g - 1) = 0, \quad L_2 = x + c = 0. \quad (137)$$

On the other hand for systems (135) we calculate

$$\mu_0 = \mu_1 = 0, \quad \mu_2 = c^2g(g - 1)^2(2g - 1)x^2, \quad \gamma_{16} = c(g - 1)^2(1 - 3g)x^3/2 \quad (138)$$

and by Lemma 1 in the case $\mu_2 \neq 0$ these systems possess finite singular points of total multiplicity two. Other two points have gone to infinity and coalesced with the singularity $[0, 1, 0]$. So we consider two cases: $\mu_2 \neq 0$ and $\mu_2 = 0$.

a) *The subcase $\mu_2 \neq 0$.* Then $c \neq 0$ and due to the rescaling $(x, y, t) \mapsto (cx, y/c, t/c)$ we may assume $c = 1$. In this case the 1-parameter family of systems (135) possess the finite singular points $M_i(x_i, y_i)$ ($i=1,2$) with the coordinates

$$x_1 = \frac{(1 - 2g)}{g}, \quad y_1 = \frac{g}{(g - 1)(2g - 1)}, \quad x_2 = -1, \quad y_2 = \frac{1}{g - 1}.$$

We detect that the singular point M_1 is located at the intersection point of the hyperbola with invariant line $L_1 = 0$ (see (137)) whereas M_2 is located on the line $L_2 = 0$ outside the hyperbola.

On the other hand taking into account (138) for systems (135) with $c = 1$ we have $\gamma_{16} \neq 0$ (due to (136)) and hence by Theorem 3 (see DIAGRAM 2) the hyperbola (137) is a simple one. So considering the condition (136) and looking at all the intervals given by this condition we arrive at the unique configuration presented by *Config. \tilde{H} .19*.

b) *The subcase $\mu_2 = 0$.* Then considering (138) and condition (136) we get $cg = 0$ and we consider two possibilities: $\gamma_{16} \neq 0$ and $\gamma_{16} = 0$.

b₁) *The possibility $\gamma_{16} \neq 0$.* Then $c \neq 0$ (and we may assume $c = 1$) and this implies $g = 0$. So we arrive at the system with constant coefficients

$$\frac{dx}{dt} = -(1 + x), \quad \frac{dy}{dt} = 1 - xy$$

possessing one finite singular point $M_1(-1, -1)$, the invariant hyperbola $xy + y - 1 = 0$ and the invariant line $x + 1 = 0$. On the other hand following Lemma 3 we detect that the line at infinity $Z = 0$ is double for these systems because Z is a common factor of degree one of the polynomials

$\mathcal{E}_1(X, Y, Z)$ and $\mathcal{E}_2(X, Y, Z)$. Moreover, since $\mu_0 = \mu_1 = \mu_2 = 0$ and $\mu_3 = -x^2y$, according to Lemma 1 we deduce that another finite singular point has gone to infinity and coalesced with $[1, 0, 0]$. We observe that M_1 belongs to the invariant line and it is outside the hyperbola, i.e. we get *Config. $\tilde{H}.24$* .

b₂) *The subcase $\gamma_{16} = 0$.* In this case $c = 0$ and we get the systems

$$\frac{dx}{dt} = gx^2, \quad \frac{dy}{dt} = 1 + (g-1)xy,$$

for which $g \neq 0$ (otherwise we obtain a degenerate system). For these systems we calculate

$$\mu_0 = \mu_1 = \mu_2 = \mu_3 = \gamma_{16} = 0, \quad \mu_4 = g^2x^4, \quad \delta_6 = (g-1)(4g-1)(x^2)/2$$

and by Lemma 1 we deduce that all four finite singular points have gone to infinity and coalesced with $[0, 1, 0]$. Moreover, for the above systems we calculate

$$\mathcal{E}_k(X) = gx^3(1 + g - xy + gxy)$$

and by Lemma 6 the invariant line $x = 0$ is a triple one.

According to DIAGRAM ?? the hyperbola is simple if $\delta_6 \neq 0$ (i.e. $4g - 1 \neq 0$) and it is double if $\delta_6 = 0$ (i.e. $4g - 1 = 0$). So we arrive at *Config. $\tilde{H}.25$* if $\delta_6 \neq 0$ and at *Config. $\tilde{H}.34$* if $\delta_6 = 0$.

2) *The case $\beta_{12} = 0$.* Then $g = 1/3$ and we calculate $\gamma_{16} = -2cx^3/9$. Since by Theorem 3 in the case under consideration the condition $\gamma_{16} = 0$ is necessary for the existence of an invariant hyperbola, we obtain $c = 0$ and we arrive at the 1-parameter family of systems

$$\frac{dx}{dt} = a + x^2/3, \quad \frac{dy}{dt} = 1 - 2xy/3.$$

For these systems we calculate $\gamma_{17} = 32ax^2/9$ and following Theorem 3 we conclude that for $\gamma_{17} < 0$ or $\gamma_{17} > 0$ or $\gamma_{17} = 0$ we obtain three different configurations due to the number and types of hyperbolas. Since $\text{sign}(a) = \text{sign}(\gamma_{17})$ setting a new parameter k as follows: $a = \text{sign}(a)k^2/3$ after the rescaling $(x, y, t) \mapsto (kx, 3y/k, 3t/k)$ (in the case $k \neq 0$) or the rescaling $x \rightarrow 3x$ if $a = 0$, the above systems become

$$\frac{dx}{dt} = x^2 + \varepsilon, \quad \frac{dy}{dt} = 1 - 2xy, \tag{139}$$

where $\varepsilon = \text{sign}(\gamma_{17})$ if $\gamma_{17} \neq 0$ and $\varepsilon = 0$ if $\gamma_{17} = 0$, i.e. $\varepsilon \in \{-1, 0, 1\}$.

These systems possess the following invariant hyperbolas and invariant lines:

$$\Phi_{1,2}(x, y) = 3 \pm \sqrt{-\varepsilon}y - xy = 0, \quad L_{1,2} = x \pm \sqrt{-\varepsilon} = 0. \tag{140}$$

We detect that these systems possess the finite singularities $M_{1,2}(\pm\sqrt{\varepsilon}, 3 \pm 1/(2\sqrt{\varepsilon}))$ (if $\varepsilon \neq 0$) and each one of the lines intersect only one of the hyperbolas.

On the other hand for systems (139) we calculate

$$\mu_0 = \mu_1 = 0, \quad \mu_2 = 4\varepsilon x^2, \quad \mu_3 = 0, \quad \mu_4 = x^2(x + 2\varepsilon y)^2.$$

Therefore by Lemma 1 we conclude that in the case $\varepsilon \neq 0$ only two finite singularities of these systems have gone to infinity and coalesced with $[0, 1, 0]$ and we get *Config. $\tilde{H}.27$* if $\gamma_{17} < 0$ and *Config. $\tilde{H}.28$* if $\gamma_{17} > 0$.

Assume now $\gamma_{17} = 0$ (i.e. $\varepsilon = 0$). Then $\mu_i = 0$ for $i = 0, 1, 2, 3$ and $\mu_4 = x^4$ and by Lemma 1 all the finite singularities of this system have gone to infinity and coalesced with $[0, 1, 0]$.

We observe that the two lines coincide and we get the invariant multiple line $x = 0$. Considering Lemma 6 for systems (139) with $\varepsilon = 0$ we calculate

$$\mathcal{E}_k(X) = 2x^3(2 - 3xy)$$

and by this lemma in the case under consideration the invariant line $x = 0$ is a triple one. Since by Theorem 3 (see DIAGRAM 2) the hyperbola (140) in the case $\gamma_{17} = 0$ (i.e. $\varepsilon = 0$) is double, we arrive at the same configuration given by *Config. \tilde{H} .34*.

4.1.2.2.2 The possibility $N = 0$. Then $(g - 1)(g + 1) = 0$ and as $\beta_{13} = (g - 1)^2 x^2 / 4$ we consider two cases: $\beta_{13} \neq 0$ and $\beta_{13} = 0$.

1) *The case $\beta_{13} \neq 0$.* Therefore the condition $N = 0$ gives $g = -1$ and we can assume $e = f = 0$ due to a translation. So we get the systems

$$\frac{dx}{dt} = a + cx + dy - x^2, \quad \frac{dy}{dt} = b - 2xy,$$

which by Theorem 3 (see DIAGRAM 2) possess an invariant hyperbola if and only if $\gamma_{10} = \gamma_{17} = 0$ and $\mathcal{R}_{11} \neq 0$. Calculations yield

$$\begin{aligned} \gamma_{10} = 14d^2 = 0, \quad \gamma_{17} = -8(16a + 3c^2)x^2 + 4dy(14cx + 9dy) = 0, \\ \mathcal{R}_{11} = -6x(2bx^3 - cdx^2y - d^2y^3) \neq 0 \end{aligned}$$

and therefore we obtain $d = 0$, $a = -3c^2/16$ and $b \neq 0$ and we may assume $b = 1$ due to the rescaling $y \rightarrow by$. So we arrive at the 1-parameter systems

$$\frac{dx}{dt} = -3c^2/16 + cx - x^2, \quad \frac{dy}{dt} = 1 - 2xy$$

possessing the invariant hyperbola and the invariant lines

$$\Phi(x, y) = 4 + 3cy - 12xy = 0, \quad L_1 = 4x - c = 0, \quad L_2 = 4x - 3c = 0. \quad (141)$$

We observe that for $c = 0$ the lines coincide and this phenomenon is governed by the invariant polynomial $\gamma_{16} = -2cx^3$. So we consider two subcases: $\gamma_{16} \neq 0$ and $\gamma_{16} = 0$.

a) The subcase $\gamma_{16} \neq 0$. Then $c \neq 0$ and we may assume $c = 4$ due to the rescaling $(x, y, t) \mapsto (cx/4, 4y/c, 4t/c)$. So we obtain the system

$$\frac{dx}{dt} = (x - 1)(3 - x), \quad \frac{dy}{dt} = 1 - 2xy \quad (142)$$

which possesses the following invariant hyperbola and invariant lines:

$$\Phi(x, y) = 1/3 + y - xy = 0, \quad L_1 = x - 1 = 0, \quad L_2 = x - 3 = 0 \quad (143)$$

and two finite singularities: $M_1(1, 1/2)$ and $M_2(3, 1/6)$. Since $\mu_0 = \mu_1 = 0$ and $\mu_2 = 12x^2$ by Lemma 1 we conclude that two finite singularities of this system have gone to infinity and coalesced

with $[0, 1, 0]$. So considering the position of the hyperbola, invariant lines and of the finite singularities we arrive at *Config. $\tilde{H}.19$* .

b) *The subcase $\gamma_{16} = 0$.* Then $c = 0$ and we get the system

$$\frac{dx}{dt} = -x^2, \quad \frac{dy}{dt} = 1 - 2xy,$$

for which

$$\mu_0 = \mu_1 = \mu_2 = \mu_3 = 0, \quad \mu_4 = x^4.$$

So by Lemma 1 all the finite singularities of this system have gone to infinity and coalesced with $[0, 1, 0]$.

On the other hand we observe that the invariant line $x = 0$ is a multiple one. For the above system we calculate $\mathcal{E}_k(X) = 2x^4y$ and by Lemma 6 we deduce that the invariant line $x = 0$ has multiplicity four. So considering the invariant hyperbola (143) (for $c = 0$) we arrive at the configuration given by *Config. $\tilde{H}.26$* .

2) *The case $\beta_{13} = 0$.* Then we have $g = 1$ and we can assume $c = 0$ due to a translation. So we get the systems

$$\frac{dx}{dt} = a + dy + x^2, \quad \frac{dy}{dt} = b + ex + fy,$$

and by Theorem 3 (see DIAGRAM 2) these systems possess an invariant hyperbola if and only if $\gamma_9 = \tilde{\gamma}_{18} = \tilde{\gamma}_{19} = 0$. Calculations yield

$$\gamma_9 = -6d^2 = 0, \quad \tilde{\gamma}_{18} = 8x^2(ex^2 - 2dy^2) = 0, \quad \tilde{\gamma}_{19} = 4(4a + f^2)x + 4dfy = 0$$

and evidently this implies $d = e = 0$ and $a = -f^2/4$ which leads to the 2-parameter family of systems

$$\frac{dx}{dt} = -f^2/4 + x^2, \quad \frac{dy}{dt} = b + fy.$$

For these systems we calculate $\mu_0 = \mu_1 = 0$, $\mu_2 = f^2x^2$ and we consider two subcases: $\mu_2 \neq 0$ and $\mu_2 = 0$.

a) *The subcase $\mu_2 \neq 0$.* Then $f \neq 0$ and we may assume $f = 1$ and $b = 0$ due to the transformation $(x, y, t) \mapsto (fx, y - b/f, t/f)$. So we obtain the system

$$\frac{dx}{dt} = (2x - 1)(2x + 1)/4, \quad \frac{dy}{dt} = y \tag{144}$$

which possesses the 1-parameter family of hyperbola:

$$\Phi(x, y) = -q/2 + qx + y + 2xy = 0, \quad q \in \mathbb{C} \setminus \{0\}$$

as for $q = 0$ we get a reducible conic.

On the other hand system (144) possesses the following invariant lines and finite singularities:

$$L_1 = 2x - 1 = 0, \quad L_2 = 2x + 1 = 0, \quad L_3 = y = 0, \quad M_{1,2}(\pm 1/2, 0).$$

Following Lemmas 3 and 6 for this system we calculate

$$\gcd(\mathcal{E}_1(X, Y, Z), \mathcal{E}_2(X, Y, Z)) = YZ(2X - Z)^2(2X + Z), \quad \mathcal{E}_k(X) = (1 - 2x)^2(1 + 2x)y/4$$

and we deduce that the invariant lines $L_2 = 0$ and $L_3 = 0$ are simple, whereas the line $L_1 = 0$ as well as the infinite line $Z = 0$ are double ones.

So considering the fact that other two finite singular points have gone to infinity and coalesced with $[1, 0, 0]$ we arrive at *Config. \tilde{H} .35*.

b) *The subcase $\mu_2 = 0$.* In this case we have $f = 0$ and as $b \neq 0$ (otherwise we get degenerate system) we may assume $b = 1$ due to the change $y \rightarrow by$ and we get the system

$$\frac{dx}{dt} = x^2, \quad \frac{dy}{dt} = 1 \quad (145)$$

which possesses the 1-parameter family of hyperbola:

$$\Phi(x, y) = 1 + rx + xy = 0, \quad r \in \mathbb{C}$$

and has no finite singularities. Calculations yield

$$\mu_0 = \mu_1 = \mu_2 = \mu_3 = 0, \quad \mu_4 = x^4, \quad \gcd(\mathcal{E}_1(X, Y, Z), \mathcal{E}_2(X, Y, Z)) = X^3 Z^2, \quad \mathcal{E}_1(X) = 2X^3$$

and considering Lemma 1 we conclude that all the finite singularities of these systems have gone to infinity and coalesced with $[0, 1, 0]$. Moreover by Lemmas 3 and 6 the invariant line $x = 0$ as well as the infinite line $Z = 0$ are of multiplicity 3. As a result we arrive at the configuration given by *Config. \tilde{H} .36*.

4.2 The possibility $M(\tilde{a}, x, y) = 0 = C_2(\tilde{a}, x, y)$

In this section we consider the configurations of invariant hyperbolas and invariant lines of quadratic systems with $C_2 = 0$, taking into account Theorem 3 (see DIAGRAM 2). Then the line at infinity is filled up with singularities and according to [28] in this case via an affine transformation and time rescaling quadratic systems could be brought to the following systems

$$\dot{x} = k + cx + dy + x^2, \quad \dot{y} = l + xy. \quad (146)$$

Following [28] we consider the stratification of the parameter space of the above systems given by invariant polynomials $H_9 - H_{12}$ in [28, Table 1 on page 754] according to possible configurations of invariant lines. So for systems (146) we calculate $H_{10} = 36d^2$ and we consider two cases: $H_{10} \neq 0$ and $H_{10} = 0$.

4.2.1 The case $H_{10} \neq 0$

Then $d \neq 0$ and as it was shown in [28, pages 748,749], in this case via some parametrization and using an additional affine transformation and time rescaling we arrive at the following 2-parameter family of systems

$$\dot{x} = a + y + (x + c)^2, \quad \dot{y} = xy. \quad (147)$$

for which we calculate

$$N_7 = 16c(9a + c^2), \quad H_9 = 2304a(a + c^2)^2$$

and by Theorem 3 (see DIAGRAM 2) for the existence of invariant hyperbola the condition $N_7 = 0$ is necessary and sufficient. So we have either $c = 0$ or $9a + c^2 = 0$. However in the second case the condition $a \leq 0$ must hold and in the case $a = 0$ we get again $c = 0$. In the case $a < 0$ we may assume $a = -1$ and $c > 0$ due to the rescaling $(x, y, t) \mapsto (\text{sign}(c)\sqrt{-a}x, -ay, t/(\text{sign}(c)\sqrt{-a}))$, therefore we set $c = 3$. Moreover the transformation

$$(x, y, t) \mapsto (2(x - 1), 4(y - x - 1), t/2).$$

sends the system (147) for $a = -1, c = 3$ to the system (147) with $a = -1$ and $c = 0$. Thus we assume $c = 0$ and we get the systems

$$\dot{x} = a + y + x^2, \quad \dot{y} = xy \tag{148}$$

which possess the following 1-parameter family of hyperbolas

$$\Phi(s, x, y) = a + 2y + x^2 - m^2y^2 = 0 \tag{149}$$

as well as the following invariant lines and finite singularities:

$$L_1 = y = 0, \quad L_{2,3} = ax^2 + (a + y)^2 = 0; \quad M_1(0, -a), \quad M_{2,3}(\pm\sqrt{-a}, 0).$$

We observe that the two lines $L_{2,3} = 0$ as well as the singular points $M_{2,3}$ are real if $a < 0$; they are complex if $a > 0$ and they coincide if $a = 0$. Moreover these three possibilities are distinguished by the invariant polynomial $H_9 = 2304a^3$.

So, considering that all the hyperbolas from the family (149) intersect the invariant line $y = 0$ at the singular points $M_{2,3}$ we arrive at the configuration *Config. \tilde{H} .39* if $H_9 < 0$; *Config. \tilde{H} .41* if $H_9 > 0$ and *Config. \tilde{H} .43* if $H_9 = 0$.

4.2.2 The case $H_{10} = 0$

In this case we have $d = 0$ and we distinguish two subcases: $k \neq 0$ and $k = 0$. Since for systems (146) with $d = 0$ we have $H_{12} = -8k^2x^2$ it is clear that this invariant polynomial governs these two subcases.

4.2.2.1 The subcase $H_{12} \neq 0$. Then $k \neq 0$ and as it was shown in [28, page 750] in this case via an affine transformation and time rescaling after some additional parametrization we arrive at the following 2-parameter family of systems

$$\dot{x} = a + (x + c)^2, \quad \dot{y} = xy. \tag{150}$$

For these systems the condition $H_{12} = -8(a + c^2)^2x^2 \neq 0$ must hold and according to DIAGRAM 2 the condition $N_7 = 16c(9a + c^2) = 0$ must be satisfied for the existence of invariant hyperbolas. On the other hand for these systems we have $H_2 = 8cx^2$ and we consider two possibilities: $H_2 = 0$ and $H_2 \neq 0$.

4.2.2.1.1 The possibility $H_2 \neq 0$. Then $c \neq 0$ and in this case we get $9a + c^2 = 0$, i.e. $a = -c^2/9 \neq 0$. Therefore due to the rescaling $(x, y, t) \mapsto (2cx, y, t/(2c))$ systems (150) could be brought to the system

$$\dot{x} = (1 + 3x)(2 + 3x)/9, \quad \dot{y} = xy. \quad (151)$$

This system possesses the 1-parameter family of the hyperbolas and three invariant lines

$$\Phi(x, y) = 4 + 12x + 9x^2 + my + 3mxy = 0; \quad y = 0, \quad 3x + 1 = 0, \quad 3x + 2 = 0, \quad (152)$$

as well as the singularities $M_1(-1/3, 0)$ and $M_2(-2/3, 0)$. It is not too difficult to convince ourselves that in this case we get the configuration given by *Config. $\tilde{H}.37$* .

4.2.2.1.2 The possibility $H_2 = 0$. Then $c = 0$ and we get the systems

$$\dot{x} = a + x^2, \quad \dot{y} = xy, \quad a \neq 0, \quad (153)$$

which possess the following family of conics and the invariant lines:

$$\Phi(x, y) = a + x^2 - m^2y^2 = 0; \quad L_1 = y = 0, \quad L_{2,3} = x^2 + a = 0 \quad (154)$$

as well as two finite singularities: $M_{1,2}(\pm\sqrt{-a}, y)$.

On the other hand we calculate $H_{11} = -192ax^4$ and therefore $\text{sign}(a) = -\text{sign}(H_{11})$. So considering the position of the invariant lines and of the hyperbolas given in (154) we obtain the configuration *Config. $\tilde{H}.40$* if $H_{11} < 0$ and *Config. $\tilde{H}.38$* if $H_{11} > 0$.

4.2.2.2 The subcase $H_{12} = 0$. Then $k = 0$ and we arrive at the family of systems (146) with $d = k = 0$ for which we have $N_7 = -16c^3$ and by Theorem 3 (see DIAGRAM 2) we have to force the condition $c = 0$. Since $l \neq 0$ (otherwise we get a degenerate system) due to the change $y \rightarrow ly$ we may assume $l = 1$ and we arrive at the system

$$\dot{x} = x^2, \quad \dot{y} = 1 + xy, \quad (155)$$

which possesses the following family of hyperbolas

$$\Phi(x, y) = 1 + mx^2 + 2xy = 0$$

and the invariant line $x = 0$. We remark that by Lemma 6 this line is triple since for this system we have $\mathcal{E}_1(X) = X^3$. So considering the absence of finite singularities of system (155) we obtain the configuration given by *Config. $\tilde{H}.42$* .

This completes the proof of statement (B) of Main Theorem.

5 Concluding comments

Details about the configurations and their realizability.

DIAGRAMS 10 and 11 give an algorithm to compute the configuration of a system with an invariant hyperbola for any system presented in any normal form and they are also the bifurcation diagrams of the configurations of such systems, done in the 12-parameter space of the coefficients of these systems.

5.1 Concluding comments for $\eta > 0$

In this section we consider the class of all non-degenerate systems in $\mathbf{QSH}_{(\eta>0)}$. According to Theorem 5, this class yields 162 distinct configurations which can be split according the following geometric classification.

- (A₁) There are exactly 3 configurations of systems possessing an infinite number of hyperbolas, namely *Config. H.160*, *Config. H.161* and *Config. H.162*, which are distinguished by the number and multiplicity of the invariant straight lines of such systems.
- (A₂) The remaining 159 configurations could have up to a maximum of 3 distinct invariant hyperbolas, real or complex, and up to 4 distinct invariant straight lines, real or complex, including the line at infinity.

Assuming we have m invariant hyperbolas $H_i: f_i(x, y) = 0$ and m' invariant lines $L_j: g_j(x, y) = 0$, the geometry of the configurations is in part captured by the following invariants:

- (a) the type of the main divisor $\sum n(H_i)H_i + \sum n(L_j)L_j$ on the plane $P_2(\mathbb{R})$, where $n(H_i)$, $n(L_j)$ indicate the multiplicity of the respective invariant curve;
- (b) the type of the zero-cycle $MS_{0C} = \sum l_i U_i + \sum m_j s_j$ on the plane $P_2(\mathbb{R})$, where l_i , m_j indicate the multiplicity on the real projective plane, of the real singularities at infinity U_i and in the finite plane s_j of a system (3), located on the invariant lines and invariant hyperbolas;
- (c) the number of the singular points of the systems which are smooth points of the curve: $T(X, Y, Z) = \prod F_i(X, Y, Z) \cdot \prod G_j(X, Y, Z) \cdot Z = 0$ where F_i, G_j 's are the homogenizations of f_i 's, g_j 's respectively, where $f_i = 0$ are the invariant hyperbolas and $g_j = 0$ are the invariant straight lines, and by their positions on $T(X, Y, Z) = 0$. This position is expressed in the proximity divisor PD on the Poincaré disk of a system, defined in Section 2.

– **We have exactly 120 distinct configurations** of systems with exactly one hyperbola which is simple:

- (i) 40 of them with no invariant line other than the line at infinity: 36 of them having only a simple line at infinity, 2 of them having a double line at infinity, and 2 of them having a triple line at infinity;
- (ii) 46 of them with only one invariant line other than the line at infinity: 39 of them having only simple lines, 3 of them with a double finite line, and 4 of them with the line at infinity being double;
- (iii) 23 of them with two distinct simple affine invariant lines (real or complex) and a simple line at infinity;
- (iv) 6 of them with three simple invariant straight lines other than the line at infinity;
- (v) 2 of them with two simple lines and one double line: 1 of them with a double finite line and 1 of them with a double line at infinity;
- (vi) 3 of them with four simple invariant straight lines other than the line at infinity.

- **We have exactly 35 distinct configurations** with hyperbolas of total multiplicity two:
 - (vii) 11 of them with no invariant straight line other than the line at infinity;
 - (viii) 5 of them with only one simple invariant straight line other than a simple line at infinity;
 - (ix) 11 of them with exactly two invariant lines which are simple other than the line at infinity, which 2 of them with a double hyperbola;
 - (x) 3 of them with exactly one double line either in the finite plane or at infinity;
 - (xi) 5 of them with three simple invariant straight lines other than the line at infinity.
- **We have exactly 4 distinct configurations** with three distinct hyperbolas:
 - (xii) 2 of them with only one invariant straight line other than the line at infinity;
 - (xiii) 2 of them with exactly two invariant lines which are simple other than the line at infinity.

5.2 Concluding comments for $\eta = 0$

In this section we consider the class $\mathbf{QSH}_{(\eta=0)}$ of all non-degenerate quadratic differential systems (3) possessing an invariant hyperbola and either exactly two distinct real singularities at infinity or the line at infinity filled up with singularities. According to Theorem 6, this class yields 43 distinct configurations which can be split according the following geometric classification.

- (A₁) There are exactly 9 configurations with an infinity of invariant hyperbolas. These configurations could have up to 3 distinct affine invariant lines which could have multiplicities up to at most 3. The configurations are split as follows:
 - (a) 2 of them with exactly two infinite singularities (*Config. $\tilde{H}.35$* and *Config. $\tilde{H}.36$*) distinguished by the type of the invariant lines divisor ILD (as defined in Section 2);
 - (b) 7 of them with the line at infinity filled up with singularities (*Config. $\tilde{H}.i$* , with $37 \leq i \leq 43$). The type of the ILD splits these configurations in three groups:
 - Group 1:** *Config. $\tilde{H}.i$* , with $37 \leq i \leq 39$, first distinguished by the number of finite singularities (3 for *Config. $\tilde{H}.39$* and 2 for *Config. $\tilde{H}.i$* , $i \in \{37, 38\}$). The last two configurations are distinguished by the number of finite singularities not located on the invariant hyperbolas (1 for $i = 37$, 0 for $i = 38$);
 - Group 2:** *Config. $\tilde{H}.i$* , with $i \in \{40, 41\}$; and
 - Group 3:** *Config. $\tilde{H}.i$* , with $i \in \{42, 43\}$. The configurations in these groups are distinguished by the type of the zero-cycle MS_{0C} ;
- (A₂) The remaining 34 configurations could have up to a maximum of 2 distinct invariant hyperbolas, real or complex, and up to 3 distinct invariant straight lines, real or complex, including the line at infinity.
 - **We have exactly 11 distinct configurations** of systems with exactly one hyperbola which is simple, and no invariant affine lines. These are classified by the total multiplicity of the real singularities of the systems located on the algebraic solutions (TMS) as follows:

- (a) only one configuration (*Config. $\tilde{H}.1$*) with $TMS = 3$;
 - (b) 5 configurations with $TMS = 5$ grouped as follows by the number of their singularities and their multiplicities:
 - one with only two singularities, both multiple and both at infinity (*Config. $\tilde{H}.2$*);
 - two with an additional finite singularity (*Config. $\tilde{H}.3$* , *Config. $\tilde{H}.4$*) but with distinct multiplicities;
 - two with two additional finite simple singularities (*Config. $\tilde{H}.5$* , *Config. $\tilde{H}.6$*) distinguished using the proximity divisor PD defined in Section 2;
 - (c) 4 with $TMS = 6$: one with only one finite singularity (*Config. $\tilde{H}.7$*); 3 with two finite singularities with the same multiplicities, distinguished by the invariant O defined in Section 2 (*Config. $\tilde{H}.i$* , with $8 \leq i \leq 10$);
 - (d) 1 with $TMS = 7$ (*Config. $\tilde{H}.11$*).
- **We have exactly 6 distinct configurations** with a unique simple invariant hyperbola and a unique simple invariant line:
- (e) one with no finite singularity (*Config. $\tilde{H}.12$*);
 - (f) one with only one finite singularity located on the hyperbola (*Config. $\tilde{H}.13$*);
 - (g) two with three finite singularities (*Config. $\tilde{H}.13$* , *Config. $\tilde{H}.15$*), distinguished by the number of finite singularities located on the invariant line;
 - (h) two with four simple finite singularities (*Config. $\tilde{H}.16$* , *Config. $\tilde{H}.17$*), which are distinguished by the proximity divisor PD (see Section 2);
- **We have exactly 9 distinct configurations** with a simple invariant hyperbola and invariant lines, including the line at infinity, of total multiplicity $3 \leq TML \leq 5$:
- (i) 5 configurations have exactly three distinct simple invariant lines (*Config. $\tilde{H}.i$* , $18 \leq i \leq 22$) distinguished by the types of ICD , MS_{0C} and the proximity divisor PD ;
 - (j) 4 configurations with exactly two invariant lines, one of them being multiple (*Config. $\tilde{H}.17$* , $23 \leq i \leq 26$). They are distinguished by the multiplicities of the two invariant lines.
- **We have exactly 8 distinct configurations** with invariant hyperbolas of total multiplicity 2:
- (k) two with two distinct hyperbolas, one with real hyperbolas (*Config. $\tilde{H}.27$*) and one with complex (non-real) hyperbolas (*Config. $\tilde{H}.28$*),
 - (l) six of them with a double hyperbola, one with 4 finite singularities (*Config. $\tilde{H}.32$*), one with 3 finite singularities (*Config. $\tilde{H}.33$*), one with 2 finite singularities (*Config. $\tilde{H}.30$*), and three without any finite singularity (*Config. $\tilde{H}.29$* , *Config. $\tilde{H}.31$* , *Config. $\tilde{H}.34$*), distinguished by the presence and multiplicity of the finite invariant line;

ACKNOWLEDGMENTS

The first author is partially supported by CNPq grant “Projeto Universal” 472796/2013-5, by CAPES CSF-PVE-88881.030454/2013-01 and by Projeto Temático FAPESP number 2014/00304-2. The first and the fourth authors are partially supported by FP7-PEOPLE-2012-IRSES-316338. The second author is supported by CNPq-PDE 232336/2014-8 grant. The third and fourth authors are partially supported by the NSERC Grant RN000355. The fourth author is also supported by the project 15.817.02.03F from SCSTD of ASM.

References

- [1] S. ABHYANKAR, *What is the difference between a Parabola and a Hyperbola?*, The Mathematical Intelligencer **10**, No. 4 (1988), 36–43.
- [2] J.C. ARTÉS, B. GRÜNBAUM AND J. LLIBRE, *On the number of invariant straight lines for polynomial differential systems*, Pacific J. Math. **184** (1998), 317–327.
- [3] V. BALTAG, *Algebraic equations with invariant coefficients in qualitative study of the polynomial homogeneous differential systems*, Bull. of Acad. of Sci. of Moldova. Mathematics **2** (2003), 31–46.
- [4] V.A. BALTAG AND N.I. VULPE, *Total multiplicity of all finite critical points of the polynomial differential system*, Planar nonlinear dynamical systems (Delft, 1995), Differ. Equ. Dyn. Syst. **5** (1997), 455–471.
- [5] D. BULARAS, I.U. CALIN, L. TIMOCHOUK AND N. VULPE, *T-comitants of quadratic systems: a study via the translation invariants*, Delft University of Technology, Faculty of Technical Mathematics and Informatics, Report no. 96–90, 1996.
- [6] S. CHANDRASEKHAR, *An introduction to the study of stellar structure*, Chicago: University of Chicago Press, 1939.
- [7] C. CHRISTOPHER, J. LLIBRE AND J.V. PEREIRA, *Multiplicity of invariant algebraic curves in polynomial vector fields*, Pacific J. Math. **229** (2007), 63–117.
- [8] G. DARBOUX, *Mémoire sur les équations différentielles du premier ordre et du premier degré*. Bull. Sci. Math. **2** (1878), 60–96; 123–144; 151–200.
- [9] J. HV. GRACE AND A. YOUNG, *The algebra of invariants*. New York: Stechert, 1941.
- [10] D. HILBERT, *Mathematical problems*, Bull. Amer. Math. Soc. **8** (1902), 437–479.
- [11] J.P. JOUANOLOU, *Equations de Pfaff algébriques*, in: Lecture Notes in Math., Vol. 708, Springer, New York, 1979.
- [12] *The geometry of quadratic differential systems with a weak focus of third order*, Canad.J. Math. **56** (2004), No. 2, 310–343.
- [13] J. LLIBRE AND X. ZHANG, *Darboux theory of integrability in \mathbb{C}^n taking into account the multiplicity*. J. Differential Equations **246** (2009), No. 2, 541–551.

- [14] A.J. LOTKA, *Analytical note on certain rhythmic relations in organic systems*, Proc. Natl. Acad. Sci. USA **6** (1920), 410–415.
- [15] R.D.S. OLIVEIRA, A.C. REZENDE AND N. VULPE, *Family of quadratic differential systems with invariant hyperbolas: a complete classification in the space \mathbb{R}^{12}* . Eletron. J. Diff. Equ. **2016** (2016), No. 162, 1–50.
- [16] R.D.S. OLIVEIRA, A.C. REZENDE, D. SCHLOMIUK AND N. VULPE, *Classification of quadratic differential systems with invariant hyperbolas according to their configurations of invariant hyperbolas and invariant lines*. Notas do ICMC **413** (2015), 1–98. Available at http://www.icmc.usp.br/CMS/Arquivos/arquivos_enviados/BIBLIOTECA_158_Nota%20Serie%20Mat%20413.pdf.
- [17] P.J. OLVER, *Classical Invariant Theory*, London Mathematical Society Student Sexts **44**, Cambridge University Press, 1999.
- [18] H. POINCARÉ, *Mémoire sur les courbes définies par les équations différentielles*, J. Math. Pures Appl. (4) **1** (1885), 167–244; Œuvres de Henri Poincaré, Vol. **1**, Gauthier–Villard, Paris, 1951, pp 95–114.
- [19] H. POINCARÉ, *Sur l'intégration algébrique des équations différentielles*, C. R. Acad. Sci. Paris, **112** (1891), 761–764.
- [20] H. POINCARÉ, *Sur l'intégration algébrique des équations différentielles du premier ordre et du premier degré*, I. Rend. Circ.Mat. Palermo **5** (1891), 169–191.
- [21] J.R. ROTH, *Periodic small-amplitude solutions to Volterra's problem of two conflicting populations and their application to the plasma continuity equations*, J. Math. Phys. **10** (1969), 1–43.
- [22] D. SCHLOMIUK AND J. PAL, *On the geometry in the neighborhood of infinity of quadratic differential systems with a weak focus*, Qual. Theory Dyn. Syst. **2** (2001), No. 1, 1-43.
- [23] D. SCHLOMIUK, *Topological and polynomial invariants, moduli spaces, in classification problems of polynomial vector fields*, Publ. Mat. **58**(2014), 461–496.
- [24] D. SCHLOMIUK AND N. VULPE, *Planar quadratic differential systems with invariant straight lines of at least five total multiplicity*, Qual. Theory Dyn. Syst. **5** (2004), 135–194.
- [25] D. SCHLOMIUK AND N. VULPE, *Geometry of quadratic differential systems in the neighbourhood of the line at infinity*, J. Differential Equations **215** (2005), 357–400.
- [26] D. SCHLOMIUK AND N. VULPE, *Integrals and phase portraits of planar quadratic differential systems with invariant lines of at least five total multiplicity*, Rocky Mountain J. Math. **38** (2008), 1–60.
- [27] D. SCHLOMIUK AND N. VULPE, *Planar quadratic differential systems with invariant straight lines of total multiplicity four*, Nonlinear Anal. **68** (2008), No. 4, 681–715.

- [28] D. SCHLOMIUK AND N. VULPE, *The full study of planar quadratic differential systems possessing a line of singularities at infinity*, J. Dynam. Differential Equations **20** (2008), No. 4, 737–775.
- [29] D. SCHLOMIUK AND N. VULPE, *Integrals and phase portraits of planar quadratic differential systems with invariant lines of total multiplicity four*, Bull. of Acad. of Sci. of Moldova. Mathematics, **56** (2008), No. 1, 27–83.
- [30] D. SCHLOMIUK AND N. VULPE, *Global classification of the planar Lotka–Volterra differential systems according to their configurations of invariant straight lines*, J. Fixed Point Theory Appl. **8** (2010), No. 1, 177–245.
- [31] K.S. SIBIRSKII, *Introduction to the algebraic theory of invariants of differential equations*, Translated from the Russian. Nonlinear Science: Theory and Applications. Manchester University Press, Manchester, 1988.
- [32] V. VOLTERRA, *Leçons sur la théorie mathématique de la lutte pour la vie*, Paris: Gauthier Villars, 1931.
- [33] N. VULPE, *Characterization of the finite weak singularities of quadratic systems via invariant theory*, Nonlinear Anal. **74** (2011), 6553–6582.
- [34] N.I. VULPE, *Polynomial bases of comitants of differential systems and their applications in qualitative theory*, (Russian) “Shtiintsa”, Kishinev, 1986.