

## DETAILED DESIGN AND CONSTRUCTION OF THE ST. LOUIS PARK ICE RINK

Craig G. Huntington\*, and Jeffrey A. Carpenter†

\*Huntington Design Associates, 6768 Thornhill Drive, Oakland, CA 94611USA  
e-mail: [craig@huntingtondesign.com](mailto:craig@huntingtondesign.com), web page: <http://www.huntingtondesign.com>

†Birdair Incorporated, 65 Lawrence Bell Drive, Amherst, NY 14221 USA  
e-mail: [jcarpenter@birdair.com](mailto:jcarpenter@birdair.com), web page <http://www.birdair.com>

**Key words:** Arch, Drainage, Fabric Reinforcement, Sectionalizing, Snow

### 1 INTRODUCTION

The structure is the cover of a new ice skating rink, owned by the City of St. Louis Park, MN. It has a PTFE-coated fiberglass fabric roof, supported on glu-laminated timber arches. The cover is 73m x 41m in plan, and supported by eight parallel arches bearing on concrete piers (Figures 1-3). The roof has a plan area of approximately 2,500 m<sup>2</sup>.

The original design of the structure was created by a project team that included the following:

RSP Architects; Minneapolis, Minnesota  
Blackwell Structural Engineers (roof structure); Toronto, Ontario, Canada  
Timber Systems (glu-laminated arch engineering); Lapeer, Michigan

The design created by this team addressed difficult challenges of snow loading, drainage, and constructability to create a beautiful structure that will be a major asset to the City of St. Louis Park for decades to come.

Construction of the membrane roof and associated cabling and anchorages was awarded to Birdair Inc. of Buffalo, New York in competitive bidding, and Birdair performed this work under subcontract to RJM Construction of Minneapolis, Minnesota. Birdair was responsible for fabrication and erection of these construction elements, as well as for the generation of final calculations and drawings that reflected their proposed fabrication and erection methods. The team assembled by Birdair for this work included the following:

Huntington Design Associates, Inc. (fabric engineering); Oakland, California  
IFS Consulting (fabric roof erector); Edmonton, Alberta, Canada

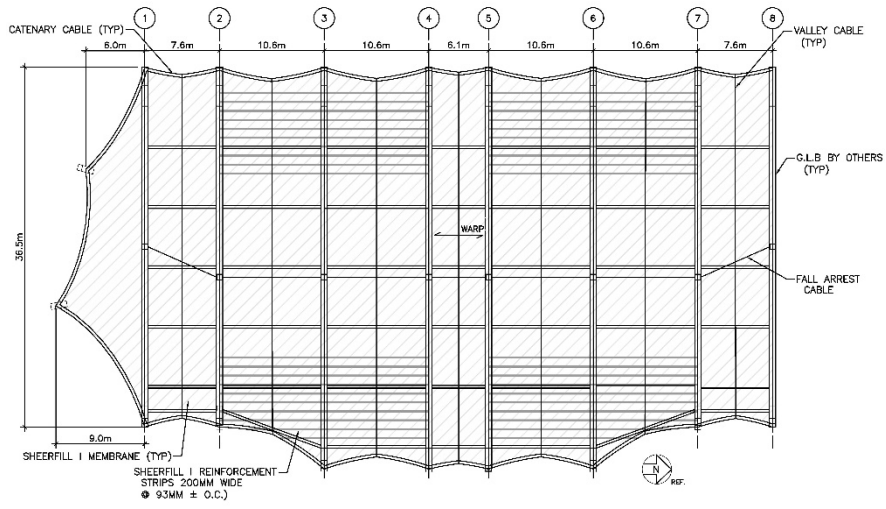

Figure 1: Roof plan



Figure 2: The roof structure nearing completion



Figure 3: Interior view, looking south, showing glu-lam arches, fabric reinforcement

## **2 DESIGN REQUIREMENTS**

### **2.1 Loading**

The structure's design is governed by the 2012 International Building Code<sup>1</sup>, which references American Institute of Civil Engineers Standard 7-10<sup>2</sup> for loading requirements. These requirements are summarized as follow:

- Live load: Nominally 1.0 kPa, but reducible to 0.6 kPa for member tributary area.
- Wind: Considered maximum wind speed of 51 m/sec., with open exposure conditions. Varying wind direction and upward and downward loading cases analyzed.
- Snow: Based on ground snow load of 2.5 kPa. Analysis considered unbalanced snow loads varying from 1.0 kPa at the arch peaks to 4.0 kPa at the eave, and from 1.0 kPa at the arch ridge lines to 4.0 kPa in the valleys midway between arches.

### **2.2 Ponding**

The arched roof form creates a flat area subject to ponding in the valleys between the apexes of adjacent arches. The potential ponding area extends well away from the centerline of the structure, due to the unbalanced snow load near the eaves. Blackwell considered ponding in their original design, and incorporated valley cables midway between the arches in order to force a drainage path towards the eaves. Our analytical work evaluated the deflected shape of the membrane under snow load to confirm if and where ponding might occur, following a criterion established by Birdair that dictates a positive drainage path for water, even when a reduced stiffness modulus is considered for the fabric. Membrane plate and other details were engineered to prevent ponding and coordinate with drainage requirements.

### **2.3 Drainage**

Visitors enter and exit the ice rink beneath the edges of the membrane roof, and it was therefore important to prevent rainwater runoff from the roof. The Blackwell design included a diverter system of upstanding 150mm tall aluminum plates, bent to conform to the membrane surface. The final design completed by Huntington Design considered alternative diverter systems comprising of a foam profile encased in PTFE-coated fiberglass membrane.

### **2.4 Services**

The design requires a path for electrical conduit along the top of each glu-laminated timber arch, as required to service lighting. The exposed timbers provide no ready location to

conceal the conduit, other than atop the arches. Detailing of the roof membrane needed to provide a clear path for the conduit beneath steel standoffs that support the membrane itself.

## **2.5 Aesthetics**

The RSP design had specific aesthetic goals, and RSP reviewed the final design documents prepared by Huntington Design in order to confirm that any revisions to details reflected these goals. This included the requirement that visual congruity be retained between connections of like kind (such as membrane plates of varying geometry and operability demands). RSP also emphasized the requirement for a distinct “rib” in the fabric profile at each arch line, and this is seen in the final details prepared by Huntington.

## **3 ERECTION CONSIDERATIONS**

### **3.1 Original Erection Scheme**

The Blackwell drawings indicated panels separated (“sectionalized”) at each arch (Lines 1-8). When Birdair began considering the installation process it was immediately clear that installation of a design matching the Design Drawings would be extremely difficult.

The issue under consideration is that during the installation, the four corners of each individual bay (28 corners in all) would need to be pulled diagonally in a connection that is designed for a pull parallel to the arch. Since there were concerns about putting the turnbuckle jaw in bending and ‘jumping’ the hardware over the hopper side plates, the alternative would be to first fasten the two membrane plates together with the slider plates and pull everything together. This is effectively the same procedure as having one membrane plate for the same connection and pulling it parallel to the arch.

Another concern with the Blackwell details was that sectionalizing is hard clamped to steel angles along each side of the arches. All of the fabric’s compensation on those edges needs to be pulled out before the edge clamping can be made, since the steel/aluminum clamping system obviously does not stretch like the fabric in the fill direction. Stretching the fabric to the corner/arch-end would be problematic and costly, since the process would not be utilizing the permanent materials to bring the fabric to that corner/arch end.

### **3.2 Birdair Erection Scheme**

The solution to these concerns was to have one fabric assembly cover all the arches (Lines 1-8), with a separate assembly for the sloped South panel. This allowed Birdair to stretch the

fabric in the fill direction on top of the arches utilizing the membrane plates and eliminated the need for diagonal pulls at the interior arches; which are the most difficult to execute.

By making this one large panel we reduced 28 corner pulls down to 4; and those 4 are over the full length and width of the large panel, giving much more leeway to stretch prior to achieving the final shape with valley and catenary cables. The membrane plates at the ends of the intermediate arches were changed from two plates to one in this scheme (Figures 4 & 5).



Figure 4: Blackwell membrane plate & drain scupper

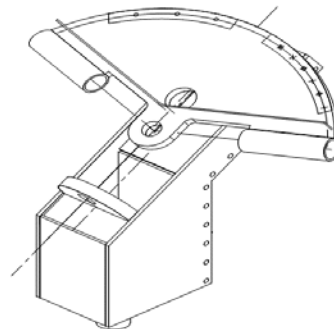

Figure 5: Membrane plate & scupper as constructed

In order to solve the problem regarding pulling in the fill direction, Birdair used hard clamping at arches 1 and 8 instead of floating clamping so that there was a fixed position to pull to using pull frames. The membrane was fastened to the intermediate arches by means of a clamping “holddown” profile that is screwed in place in the field, making it possible to pull all the fill compensation out and allowing the membrane to find its equilibrium position prior to fastening it to the arches (Figures 6 & 7). Pulling such a large panel into place was difficult. It required a very long hard day for deployment in order to get all the necessary components rigged, attached, and secured for the night. However, this was seen as a more streamlined process to perform the installation efficiently, and led to a better end-product for the owner.

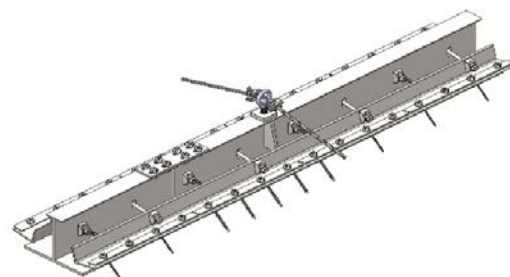
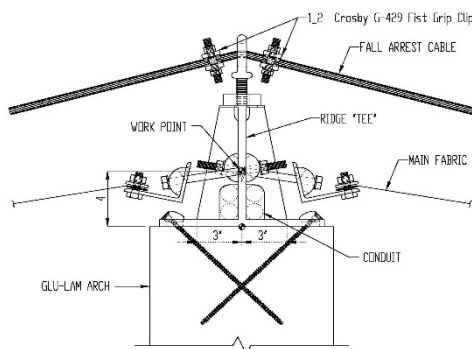

Figure 6: Blackwell top of arch detail (section & isometric)

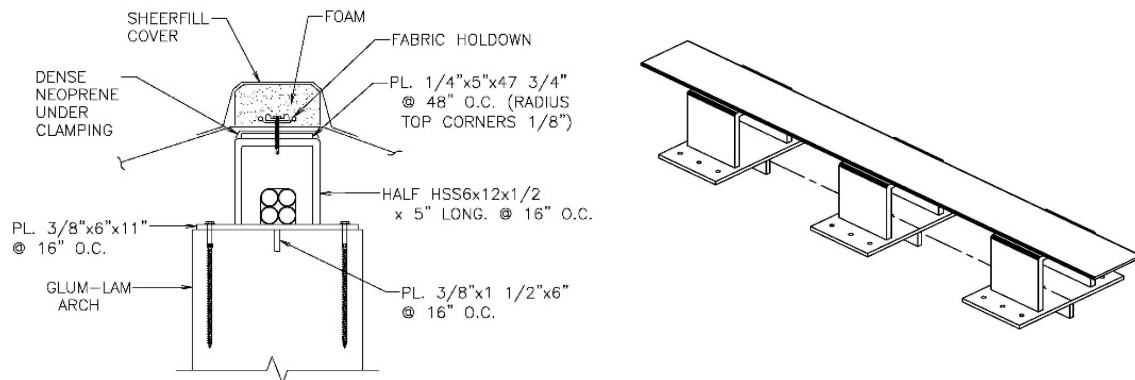

Figure 7: Top of arch detail as constructed (section & isometric)

## 4 DESIGN SOLUTIONS

### 4.1 Membrane Stresses

Governing downward load is generally created by snow load, rather than live load or combined partial live plus snow load. Warp fiber membrane stress as high as 2220 N/5cm occur near the roof eaves in the 10.7m wide bays under unbalanced snow loading. Using Sheerfill I fabric with a warp strip tensile strength of 8959 N/5cm provides a factor of safety of 4.0, less than the requirement of American Society of Civil Engineers Standard 55-10<sup>3</sup> for a factor of safety of 5.0 under snow load.

Several approaches were evaluated as solutions to the warp fiber overstress. First was the addition of “snow cables” beneath (and unsecured to) the fabric as a means of sharing some of the load carried by the warp fibers. In order to reduce the maximum warp stress to acceptable levels, three snow cables running generally perpendicular to the arches are required near the eaves on each side of the arch crown, with a seventh cable required at the crown in order to raise the fabric crown and avoid ponding in this area. The fabric lifts clear of the cables under wind uplift, and the snow cables are therefore deleted from the model under these load cases. This approach was rejected due to the architect’s aesthetic objection.

A second approach evaluated analytically was changing the uniform prestress field of 175 N/5cm in both warp and fill to an unbalanced field of 175 N/5cm in warp and 350 N/5cm in the fill. This increases the sag of the fabric between the arches, providing more efficient support of downward load. However, analysis showed that substantial areas of warp fiber

midway between the arches go slack under wind uplift loading while “popping through” into reversed curvature. The potential for the fabric to flap under such wind conditions argued against the unbalanced stress field as a ponding solution.

The final solution involved a combination of strategies. First, the fabric was laboratory tested for strip tensile strength, and the strongest material was strategically placed in high-stress areas during the patterning process. Second, the St. Gobain Sheerfill I fabric was reinforced with 200mm wide Sheerfill I reinforcement strips spaced 910mm on center in the remaining areas of overstress. The reinforcement strips are of course highly visible under certain lighting conditions, but their orderly pattern was considered visually acceptable.

#### **4.2 Ponding Avoidance**

Our initial analysis of the structure omitted the valley cables midway between arches that were a part of the Blackwell design, in order to test whether the design could be simplified in this manner. This analysis indicated areas of roof ponding under the unbalanced snow load. As with the warp fiber overstress, the area of ponding occurred only in the wider (10.7m) bays, and well away from the arch apexes, in the region closer to the eave where higher snow loads occur. Subsequent analysis indicated that valley cables provided an effective drainage path, and a reliable solution.

#### **4.3 Top of Arch Details**

Inverted U-shaped steel standoffs were provided atop each arch to accommodate the passage of electrical conduits between the arch tops and the membrane above (Figure 7). Analysis assumed complete membrane failure in alternate bays, resulting in large horizontal forces perpendicular to each supporting arch. Aluminum extrusions secure the membrane to the tops of the standoffs, and vertical steel shear tabs are welded to the standoff baseplates and fitted into slots cut into the top of each arch. These transmit the differential horizontal forces to the arches without using fasteners loaded in shear perpendicular to the grain of the timber.

#### **4.4 Drainage**

The design incorporates foam-filled fabric water diverters around the perimeter of the membrane to control water runoff (Figure 9). The diverters are positioned to assure positive slope to drainage holes in the membrane plates at the ends of each arch, where the water is gathered into scuppers and diverted to pipes passing to grade. Detailing of a transition closure at the intersection of the diverters and valley cable closures was done in the shop for efficiency, and provides continuous water flow over the intersection.

#### 4.5 Membrane Plate Details

Membrane plates at interior column Lines 2-7 and the two south piers provide adjustable anchorage for the membrane corners, with sleeved catenary cable terminations to each side (Figure 10). Water diverters to each side of the glu-lam arch terminate on the fabric just above the membrane plate, and the water that then passes onto the membrane plate is gathered by upstanding gutter plates and directed through a drain hole into a steel scupper assembly that is in turn bolted to the end of the glu-lam arch.

A rod and clevis mechanism provides adjustable anchorage of the membrane plate to a fixed plate welded to the scupper assembly. The design criteria assumed complete failure of the membrane to one side of each arch. This introduces large transverse forces to the membrane plates, which are secured against lateral displacement by guide plate assemblies that are in turn anchored to the glu-lams by pairs of 25mm diameter bolts that are drilled through the full depth of the glu-lams.

#### 4.6 Fabric Details

The structure employs conventional heat welding for seams and application of the reinforcement strips. Fabric is secured at the two ends (Lines 1 & 8) by cord edges secured by aluminum clamp bars. Fabric holdowns at the arch tops have the capacity to develop the full membrane strength, in order to provide a safe connection in the event of full membrane failure to one side of the arch.

Two bays of the structure (Lines 2-3 and 6-7) have large differences in the length of arch to either side, which results in the tendency of the valley cable to “wander” across the membrane under varying load conditions. At these locations, the cable is restrained by passing through a fabric cuff of the type normally employed to contain catenary edge cables. In the remaining bays, the valley cable is overlain by a simple cover strip (Figure 8).

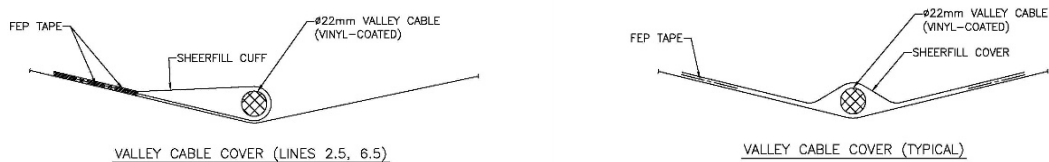

Figure 8: Valley cable lateral restraint cuff (Lines 2.5, 6.5) (left) and cover (other locations) (right)



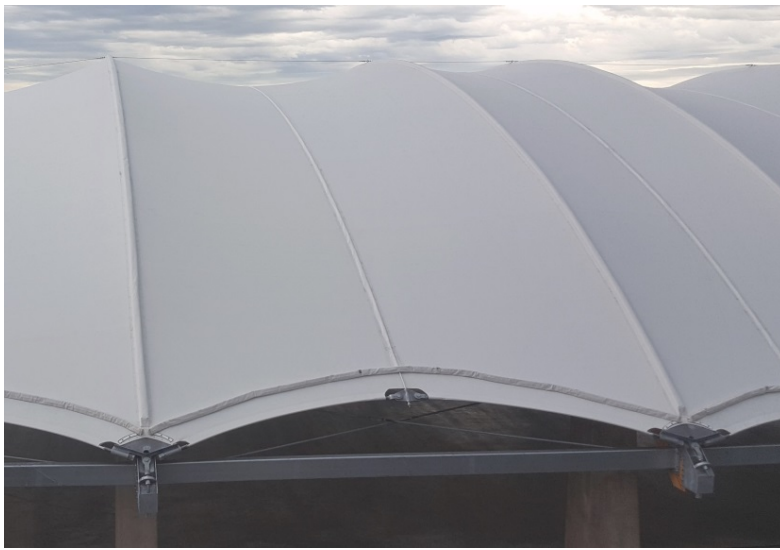

Figure 9: Diverter detail at membrane edge



Figure 10: Typical "floating" membrane plate

## 5 PATTERNING & FABRICATION

### 5.1 Membrane Patterning and Fabrication

Patterning of the membrane was carried out in a special way to utilize stronger goods in areas of high stress, in order to minimize reinforcement strips and maximize capacity (see Figures 1, 3, 11 for fabric reinforcements). Rolled goods were tested both at the supplier and in Birdair's quality lab to determine the actual strength of each roll. Rolls were then grouped by strength and by biaxial test results (compensations) to determine the most efficient layout of the material. Rolls with specific strengths and compensations were grouped together with similarly stressed areas within the assembly (i.e. higher strength goods with similar compensations were paired with the higher stressed areas and so on). Birdair was also careful to use reinforcing strips from the same rolled goods as the main membrane for more efficiency and integrity during fabrication and erection.

During the patterning and detailing process, Birdair carefully noted, in tabular format, the distance to pull each ridge and valley during the fabrication process so that these multi-layer areas would not be too stiff for the installer to pull out. Patterning of complicated details such as the interface of the valley cables and diverter cuffs were carried out by

mocking up first with paper, then with fabric in Birdair's quality lab, then sending those mock-ups to Birdair's fabrication plant for execution.

## **5.2 Steel Fabrication**

In order to meet fabrication schedule, two separate steel fabricators were used. The fabrication was broken up into separate lots to avoid compatibility issues. Arch-top weldments were done by one fabricator while the arch end weldments and membrane plates were performed by another. In this way, there would be no fit-up issues between the fabricators. The arch-top weldments were further broken up into two separate fabrication/shipment lots in order to provide materials to the site in a timely fashion to stage the work. Due to the slight curvature of the arches with respect to the weldments, some weldments were fabricated in a jig while others were fabricated flat and bent to shape in place. The bending was of the elastic type and tested out on a sample to prove it could be done by hand so that this would not pose any additional work for the installers.

## **6 ERECTION**

### **6.1 Steel Weldments and Preparation**

Prior to erection of the glu-lam arches, the glu-lam contractor needed to assemble the arches at the ground level. IFS took this opportunity to get many of the arch-top weldments in place before the glu-lam contractor erected the arches with their crane. This proved to be an efficient process both in terms of schedule and cost. While the arches were at ground level, IFS worked with the glu-lam contractor to drill thru-width holes in the glu-lam beams in order to attach the arch-end weldments. These would have been better bored in the shop, but project scheduling did not allow this. On the contrary, there were through-depth holes to be drilled for hold-down hardware related to the membrane plates and these were better done in the controlled shop environment due to their relatively higher complexity of execution than the through-width holes, so these were held to a higher priority in the design phase. Further preparation took place in the padding and protection of the weldments during this phase so that the membrane wouldn't tear when being unfurled along the arches.

### **6.2 Membrane Installation & Tensioning**

As previously mentioned, the initial spreading and securing of the large fabric panel made for a long hard day. Three cranes were used with spreader beams to position the fabric at the ridge (Figure 12). Next, the membrane was unfurled along the direction of the arches, cables were roughly installed, and everything was secured for the night with ropes, come-

alongs, and special clamps. The next few days were also challenging as the fabric was incrementally pulled to the arch ends and corners, mainly in the fill direction. As a result of these challenges, this is the range of time when the installers began calling the Engineering team to verify things were designed correctly. After incrementally pulling the membrane to the 4 corners the team found that the membrane actually fit quite well at those corners. At one point, the installers also surmised that the valley cables were designed too long but after careful investigation, it was found that they were correct and that the membrane simply hadn't been fully tensioned in the fill direction.

The smaller south fabric panel had its own set of challenges. Because it was smaller, there was less of a field of fabric to spread error. As a result, the installation team made some minor adjustments to the perimeter at the high corners in order to avoid wrinkles there.

Review of the completed installation supports the decision to erect a single large fabric panel. The challenges at the corners that presented themselves on the large and small panel would have likely occurred similarly on the 7 subpanels between the trusses had they been separate panels. This, combined with the enormous amount of hard clamping if separate panels were used in each bay would have been quite a time consuming and laborious task.



Figure 11: Fabric reinforcements during erection



Figure 12: Three cranes with spreader bars placing fabric

### 6.3 Coordination with Top of Arch Electrical, etc.

Coordination of installation of the electrical systems with the arch-top weldments was handled on-site. The contractors worked out the sequencing amongst themselves with the

guidance of general contractor RJM Construction. One omission that occurred as a result of multiple versions of the shop drawings was that some holes for electrical wire pass-through were missed on the arch-end weldments, so these needed to be drilled in the field.

#### 6.4 Diverters & Closures

Diverters and Closures present a challenge on jobs of any size and complexity because they are done near the end of the job, they have relatively little to no tension in them. The ridge closures were specially patterned due to the ribbed-look condition atop the arches and this proved effective in getting the closures looking nice (Figure 13). Valley closure-to-diverter details were prepared in the shop, so this was not something the field team needed to spend as much time on (Figure 14). The diverters themselves are challenging to install on any job because the foam needs to be relatively tight in the diverter cuff to make them look nice, which creates difficult in sliding the foam into the cuff. However, the end result is functional and aesthetically pleasing.



Figure 13: Fabric closure at arch top



Figure 14: Valley closure / diverter intersection

#### REFERENCES

- [1] *International Building Code*, International Code Council, 2012.
- [2] *ASCE Standard 7-10 Minimum Design Loads for Buildings and Other Structures*, American Society of Civil Engineers, 2010
- [3] *ASCE Standard 55-10 Tensile Membrane Structures*, American Society of Civil Engineers, 2010