



Copyright © 2016 American Scientific Publishers
All rights reserved
Printed in the United States of America

Advanced Science Letters
Vol. XXXXXXXXX

Frame effects on OITC of fixed and open glass windows

Christina Mediasitika*¹, Luciana Kristanto¹, Juliana Anggono², Fefen Suhedi³, Hariyati Purwaningsih⁴

¹Department of Architecture Petra Christian University, Surabaya 60236, Indonesia

²Department of Mechanical Engineering Petra Christian University, Surabaya 60236, Indonesia

³Research and Development Center for Housing and Settlement, Ministry of Public Works and Housing, Bandung 40622 Indonesia

⁴Department of Material Engineering, Institut Teknologi Sepuluh Nopember, Surabaya 60111 Indonesia

The effect of a frame around glass fixed windows on outdoor-indoor transmission class (OITC) was studied here. Three frame materials were selected, i.e. timber, Aluminum and unplasticized Poly Vinyl Chloride (uPVC). The use of real open window (to differentiate it from partially open double layered window) for natural ventilation was also studied. The top hung style was selected due to common usage and the possibility of noise blockage by the shutter. Laboratory test complies with ASTM E-90 was employed. The study showed that weight and density, which play significant roles in sound insulation quality of a material was not borne out for the window frame. Here, timber as the heaviest material gave lowest OITC and transmission loss (TL) contour. This was due to the absence of sealant and rubber strips which are unusual for timber caused by large thermal expansion coefficient. Top hung openings of 5° and 10° showed similar transmission loss contours, but the OITC of the 5° open window was slightly higher than the 10°.

Keywords: Fixed Window, Open Window, Frame, Transmission Loss, OITC.

1. INTRODUCTION

Buildings reside in the tropics experience excessive solar radiation throughout the years. Here, the use of lightweight materials and openings to maintain the indoor comfort of naturally ventilated buildings is common. Even for air conditioned buildings, the needs to sometimes open the windows for fresh air is not avoidable. With the increase of environmental noise, traffic noise, in particular, the use of a 'real' open window for natural ventilation is impractical. The term of a real open window is applied here to separate it from a partially open double layered window.

When compared to heavy and high-density materials, the use of lightweight or breathable materials reduces sound insulation quality¹⁻³. Sound transmission class (STC) and outdoor-indoor transmission class (OITC) of thin and transparent materials are lower than thick

and opaque materials⁴⁻⁶. The use of a real open window allows noise intrusion into living spaces even worse. However, since an open window is common and significant for natural ventilation, information on the sound insulation quality of a real open window is important for users to consider a better application.

Here the term of a real open window is applied since there were studies of sound insulation of non-real open windows⁷⁻⁹. Buratti^{7,8} focused more on the use of various ceilings to support the work of an open window. Ford and Kerry⁹ studied a partially open double glazing window which is inadequate for naturally ventilated building in the tropics¹⁰.

Besides the critical issue of noise transmission by an open window, usage of various material for window frame was also raised. Typical frame materials in Indonesia are timber and later, Aluminum (Al). A good quality timber such as teak (*Tectona grandis*) is preferred, but this is not widely utilized due to its price. Today, rather than using low-quality timber, Indonesians tend to

*Email Address: eviutami@petra.ac.id

use Aluminum for window and door frames. The aluminum frame is also available in various brands and quality. After the trend of Aluminum frame, recently, some buildings in Indonesia begin to use unplasticized Poly Vinyl Chloride (uPVC) frame. It was triggered by a promotion uPVC gives more benefits than the earlier frame materials. The high price is still an obstacle in using a uPVC frame. When using Aluminum or uPVC, sealant and rubber strips are applied, but not in the case of timber. The absence of sealant on timber is due to high coefficient thermal expansion¹¹. For frame made from good quality wood such as teak which the thermal expansion coefficient is lower than low-quality wood, the sealant may be applied, but it remains unusual.

2. METHODS

Examinations of fixed glass windows with three frame materials and open windows with different degree of openings were conducted in accordance with the following method.

- Selection of frame materials was conducted based on typical frame materials used in Indonesia, i.e. timber and Aluminum (Al). It was added by unplasticized Poly Vinyl Chloride (uPVC) frame as the latest frame material in buildings in Indonesia.
- The open window was selected with consideration of window types that may partially block outdoor noise. The most common window types are casement, top hung, and louver. A top hung window was selected since the shutter is positioned perpendicular to the sound source. It was predicted to be a good blockage.
- Glass type and opening dimension on the tested wall were determined as fixed variables. It based on earlier studies where thickness and dimension played important roles in the decrease or increase of OITC. Thicker glass owns higher OITC than thinner ones¹². Larger glass dimension decreases OITC than smaller ones¹². A fixed glass thickness of 5 mm and an opening on the wall of 800 mm x 1200 mm were determined (Fig.1,2,3).
- A testing method conforming to ASTM E90-0913 was employed here and a specific condition based on Annex. 3, i.e. the use of a composite wall system was

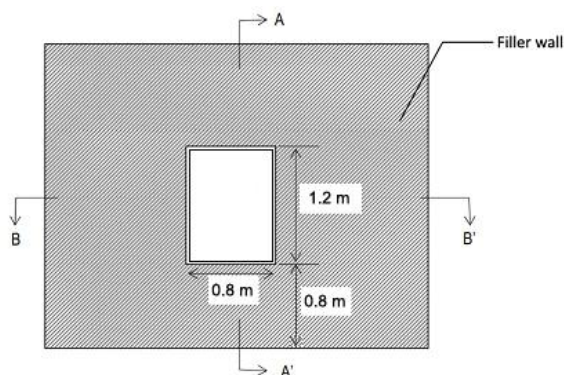

Fig 1. Front view of composite wall specimen.

employed. This method corresponds to the typical window in Indonesia. It is mostly a combination of opaque and transparent walls. The opaque wall is constructed of lightweight bricks for multistory buildings or red bricks for domestic or single story buildings.

Reverberation chambers conforming to ASTM E90-09¹³ were utilized to conduct the test, with room layout as in Fig. 7 and 8. The temperature and relative humidity (RH) during the testing period were 25° - 26°C and 80% - 90%.

- In the composite wall system, a filler wall was developed. It was suggested to use filler wall with OITC of roughly 15 above the predicted OITC of the tested specimen. In this case, lightweight bricks plastered one side with a total thickness of 113 mm were used (Fig.1, and Fig. 2). The filler wall was tested prior to specimen installation, which gave STC 37 and OITC 34. For a reference, an open window gave STC 10¹⁴. This study used reference of STC due to unavailability of reference of OITC.
- Bruel & Kjaer 2-channel building acoustics system consisting of power amplifier type 2734 and 4292 omnidirectional loudspeakers as sound sources, 2 pieces of type 4189 omnidirectional microphones as sound sensors, and 2-channel handheld analyzer type 2270 as the main instrument data processor were employed. The microphones were calibrated using type 4231 before the testing stage.
- At first, the test was conducted for fixed glass windows with three different frame materials, then for open top hung windows also with three different frame materials. The opening of the shutter was tested for three angles, i.e. 0° (closed), 5°, and 10°. Ten degrees of an opening were considered as the maximum effective for top hung type so as not to obstruct corridor way and for safety reason.



Fig. 2. Front view of composite wall specimen.

Table.1. Specimen specification

No.	Frame Material	Window specification	Frame + glass weight (kg)
1	Timber (Camphor wood)	The dimension including frame was 800 mm x 1200 mm, the dimension of frame only section was 50 mm x 100 mm (fixed window) and 110 mm x 100 mm (open window), with Asahi's monolithic glass of 5mm thickness (Fig. 4).	Fixed window 21.5 Open window 26.5
2	Aluminum (YKK brand)	The dimension including frame was 800 mm x 1200 mm, the dimension of frame only section was 44.5 mm x 101.6 mm (fixed window) and 74.5 mm x 101.6 mm (open window), with Asahi's monolithic glass of 5mm thickness (Fig.5).	Fixed window 10.5 Open window 14.0
3	uPVC (Terryham Proplas brand)	The dimension including frame was 800 mm x 1200 mm, the dimension of frame only section was 60 mm x 60 mm (fixed window) and 80 mm x 950 mm (open window), with Asahi's monolithic glass of 5mm thickness (Fig. 6).	Fixed window 14.5 Open window 21.0

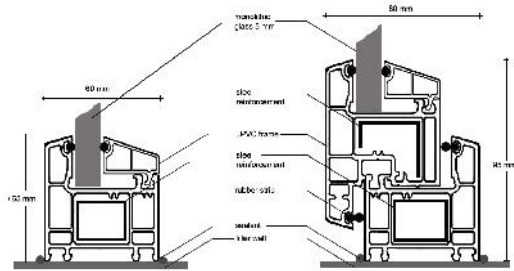

Fig.6. Detailed section of the uPVC frame of fixed (left) and open (right).

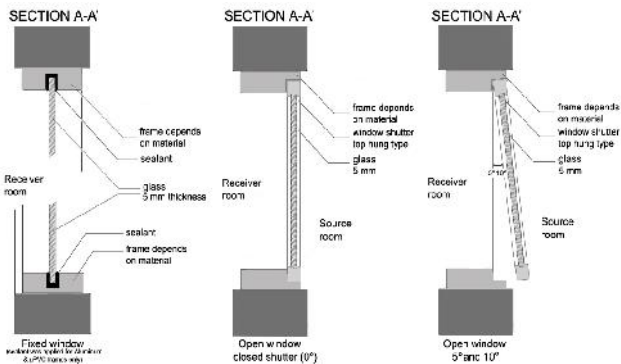

Fig 3. Schematic A-A' sections of the wall and the window. The details depend on whether fixed or open and frame materials.

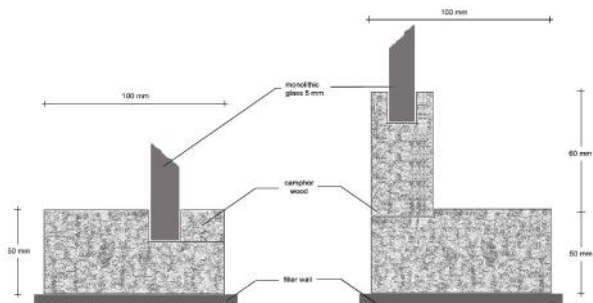

Fig. 4. Detailed section of the timber frame of fixed (left) and open (right).

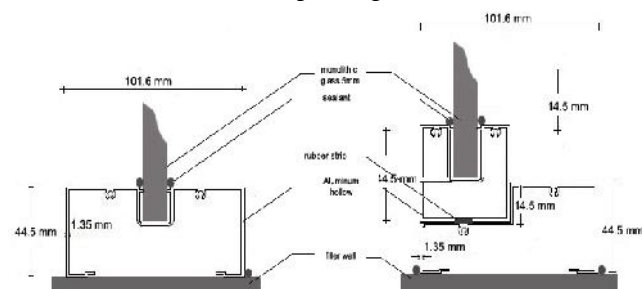

Fig.5. Detailed section of the Aluminum frame of fixed (left) and open (right).

3. FINDING AND DISCUSSION

Earlier studies which suggested light materials or open features on wall dropped the sound insulation quality of the wall⁴⁻⁶ was strengthened in this study. Fig 9, 10 and Table 2 show that TL contour and OITC of fixed windows and open windows were significantly lower than the filler wall. Weight and density of material played significant roles in providing good sound insulation⁶. A heavy and high-density material gave better sound insulation⁶. However, seemed it was not the case here. Camphor wood used in this study was heavier than the uPVC, but the TL contour and single number of OITC gave lower value than the uPVC. The camphor wood

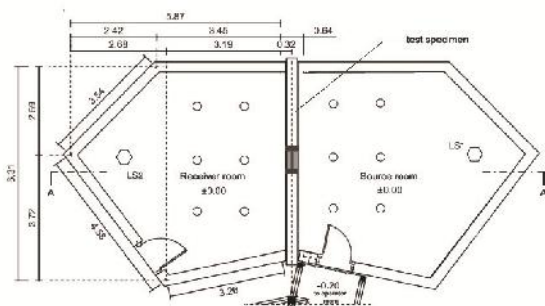

Fig 7. Plan of the testing rooms and the equipment layout.

Fig 7. Plan of the testing rooms and the equipment layout.

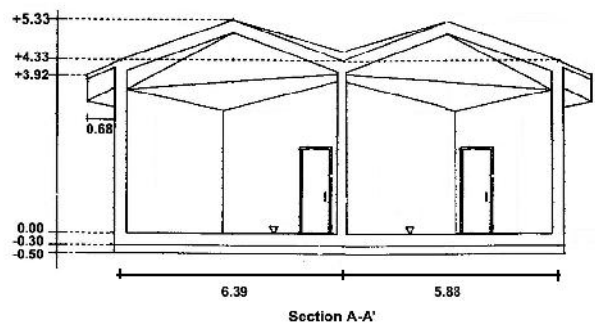

Fig 8. A-A' section of the testing rooms.

frame gave even lower TL contour compared to the Aluminum frame which was very lightweight. Learning from Fig. 4, 5, and 6, we consider the low OITC and TL contour were due to the absence of sealant and rubber strips on the timber. By Fig. 6 in particular, we clearly notice the uPVC frame had many rubber strips and sealant. These two features were significant in blocking the sound pathways.

For an open timber window, the existence of a gap between layers reduced the material capability to insulate sound significantly, even when the openable window was closed (Fig. 9). The OITC and TL contour of the fixed timber window, even lower than the open window of 0° (closed shutter) of Aluminum and uPVC frames.

When the open window was really open with the degree of opening 5° and 10°, the TL contour dropped even more significant. Fig. 10 and Table 2 show very low TL contours and very low OITC of the open windows of all frames. In general, the timber frame windows gave lowest TL contour and lowest OITC compared to the others within fixed and open 0° types. In the timber frame windows, significant gaps were existed to accommodate thermal expansion. Also, for an open timber frame window, a wide gap between frame and shutter is typical for ease of use. A gap between materials did not exist when using Aluminum and uPVC. These materials have low coefficient of thermal expansions¹⁵ so the frame and the shutter can be installed very close each other. It was even better in uPVC as rubber strips are also attached between layers.

Table.2. Transmission Loss (dB) and OITC

Freq	A	B	C	D	E	F	G	H	I	J	K	L	M
80	41	28	29	33	24	31	31	18	2	1	15	15	18
100	37	28	28	28	25	29	29	18	1	1	17	17	16
125	31	19	20	19	15	21	21	10	1	9	9	9	9
160	34	22	18	21	13	22	21	5	7	6	5	5	4
200	29	19	19	20	16	19	20	6	7	7	4	4	4
250	30	19	20	21	16	20	21	7	9	8	4	5	5
315	29	20	21	22	17	21	22	7	8	9	4	6	6
400	28	20	20	21	16	21	22	7	8	7	5	5	3
500	32	22	23	23	18	23	23	6	7	6	4	4	3
630	36	25	27	27	19	26	27	6	6	6	4	4	4
800	38	27	28	29	20	28	29	6	6	5	5	4	4
1000	41	28	30	31	20	29	31	6	6	5	5	5	4
1250	44	27	31	33	21	32	34	6	6	6	6	5	4
1600	47	28	31	35	22	33	35	7	6	6	6	4	4
2000	49	27	29	32	22	31	33	7	6	6	6	4	5
2500	51	23	26	29	19	28	31	7	7	8	6	5	6
3150	53	22	22	27	16	26	31	8	8	1	6	6	7
4000	55	25	26	29	15	27	33	8	9	1	6	6	6
OITC	34	23	24	25	18	24	25	7	7	7	5	5	5

* Legend of Table 2: A is the filler wall (lightweight bricks plastered toward source room with a total thickness 113 mm), B is the fixed window with timber frame, C is the fixed window with Aluminum frame, D is the fixed window with uPVC frame, E is the open window with timber frame with closed shutter (0°), F is the open window with Aluminum frame with closed shutter (0°), G is the open window with uPVC frame with closed shutter (0°), H is the 5° open window with timber frame, I is the 5° open window with Aluminum frame, J is the 5° open window with uPVC frame, K is the 10° open window with timber frame, L is the 10° open window with Aluminum frame, and M is the 10° open window with uPVC frame. The OITCs were calculated from the TL of 1/3 octave band frequency according to ASTM E1332-90¹⁶.

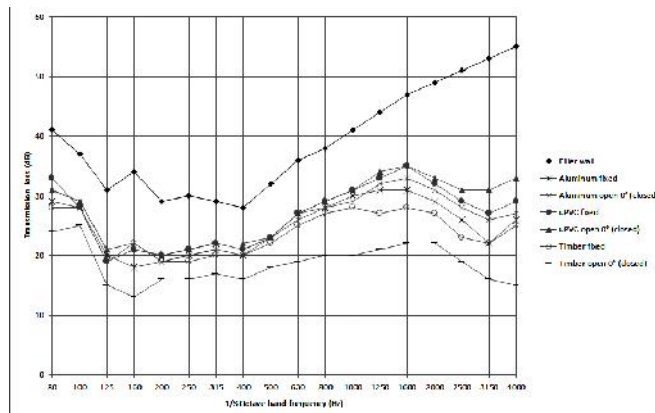

Fig. 9. Transmission loss of the filler wall, the fixed windows and the 0° open windows (closed shutter).

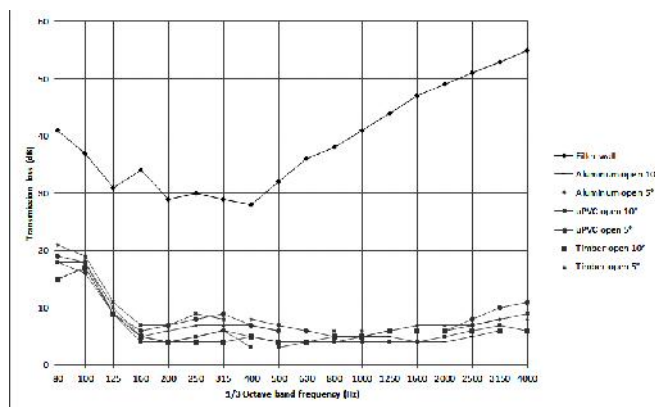

Fig. 10. Transmission loss of the filler wall and the 5° and 10° open windows.

4. CONCLUSIONS

This study concludes the timber frame used for fixed glass window gave similarly but slightly lower TL contour than the contour of Aluminum and uPVC. The similar contours mean the materials have similar critical frequencies. It also means the absence of sealant and rubber strips had a small impact on the TL contour and OITC here. Nevertheless, when the timber frame was installed for a top hung open window, even with closed shutter, the window gave a significantly lower TL contour and OITC. The TL contour and OITC of the fixed timber frame even lower than the open Aluminum and uPVC frames with closed shutters. Here, material weight did not play a role on sound insulation, all depended on the gaps filler which was sealant and rubber strips. The open top hung window with a smaller opening degree of 5° gave slightly higher TL contour and OITC value than the 10° opening.

ACKNOWLEDGMENTS

This study was fully funded by Ministry of Research, Technology and the Higher Education Republic of Indonesia under the scheme of Hibah Kompetensi under the project “Acoustical Characteristic of Architectural

Glass in Warm Humid Climate” with contract number 023.04.1.673453/ 2015 (made through Kopertis Wilayah VII).

REFERENCES

- [1] JD Quirt, Sound transmission through windows I single and double glazing. *J. Acoust. Soc. Am* 72 (1982) 834-844.
- [2] JD Quirt, Measurement of the sound transmission loss of windows. *Building Research Note* 72 (1981) 1-7.
- [3] Garg N, Sharma O and Maji S. Experimental investigations on sound insulation through single, double & triple window glazing for traffic noise abatement. *J Sci Ind Res* 70 (2011) 471-478
- [4] Massart Thierry, Meuter Cedric, V B Laurent. On the complexity of partial order trace model checking, *Inform. Process. Lett.* 106 (2008) 120-126.
- [5] CE Mediatika, L. Kristanto, J. Anggono, F.Suhedi and H. Purwaningsih, Sound transmission class (STC) of fixed window glazing in warm humid environment, *Proc 7th International Conference on Environmental Science and Development (ICESD)*, Athens, 2015.
- [6] CE Mediatika, L. Kristanto, J. Anggono, F.Suhedi and H. Purwaningsih, Building glass OITC in warm temperature, *Procedia Engineering* 145 (2016) 630-637.
- [7] P. Lord and D. Templeton, *Detailing for acoustic*, Taylor Francis, (1996) 103.
- [8] C.Buratti, Indoor noise reduction index with open window, *Applied Acoustics* 63 (2002) 383-401.
- [9] C.Buratti, Indoor noise reduction index with an open window (part II), *Applied Acoustics* 6 (2006) 431-451.
- [10] R. D. Ford and G. Kerry, The sound insulation of partially open double glazing, *Applied Acoustics* 6 (1973) 57-72.
- [11] Mediatika, CE, Design solution for low-cost housing in hot humid regions with reference to particulate matter and noise reduction, 2000, Department of Architecture, University of Strathclyde, Glasgow, UK, unpublished Ph.D. dissertation.
- [12] ----, The shrinkage and expansion of wood, available on <http://www.wood-database.com/wood-articles/dimensional-shrinkage/> accessed on May 12th, 2016.
- [13] ----, Sound investment how the acoustical properties of building products are measured and why this is important, available on http://www.jeld-wenresearch.com/_pdfs/Sound_Investment.pdf, accessed on Sep 28th, 2015.
- [14] ASTM E90-09. Standard test method for laboratory measurement of airborne sound transmission loss of building partitions and elements. American Society for Testing and Materials, West Conshohocken, PA, 19428-2959 USA, 2009.
- [15] R. McMullan, *Environmental Science Handbook*, London: MacMillan Press Ltd, 1992, p.202.
- [16] ----, Coefficient of thermal expansion for various materials at different temperatures: technical report, Balseal Engineering, 2004, available on <http://www.balseal.com/sites/default/files> accessed on Sep 28th, 2015.
- [17] ASTM E1332-90, Standard Classification for Determination of Outdoor-Indoor Transmission Class, American Society for Testing and Materials, West Conshohocken, PA, 19428-2959 USA, 1998, superseded by ASTM E1332-10a, Standard Classification for Rating Outdoor-Indoor Sound Attenuation, American Society for Testing and Materials, West Conshohocken, PA, 19428-2959 USA, 2010.

Received: Accepted: