



Expertise  
and insight  
for the future

Eyasu T. Alemu

# Software Defined Radios and NI USRP

Metropolia University of Applied Sciences

Bachelor of Engineering

Electronics

Bachelor's Thesis

29 May 2020

Author	Eyasu T. Alemu
Title	Software Defined Radios and NI USRP
Number of Pages	25 pages + 3 appendices
Date	29 May 2020
Degree	Bachelor of Engineering
Degree Programme	Electronics
Professional Major	
Instructors	Janne Mäntykoski, Senior lecturer
<p>The main objective of this study is to elaborate the differences between Hardware radio communication systems and Software Defined Radios.</p> <p>The report gives a broad coverage for the hardware communication systems namely, Cellular connectivity, Bluetooth, and Wi-Fi. It also covers architectures of Software Defined Radios. Following that approach it further touches the advantages and there is a list of popular SDRs in the present day.</p> <p>A device called NI USRP connected to a computer running LabVIEW NXG was used at the electronics laboratory to perform experiments. In this report, only a portion of it was achieved.</p> <p>After the study was completed, It was understood that Software Defined Radios have huge potential applications in the present day and in the future.</p>	
Keywords	LabVIEW NXG , Radio Communication, SDR

# Contents

1 Introduction	1
2 Radio Hardware	2
2.1 Radio Background and History	2
2.2 Propagation of Radio Waves	2
2.3 The Radio Frequency Spectrum	3
2.4 Modern Radio Communication Systems	4
2.4.1 Cellular Connectivity	4
2.4.2 Wi-Fi Connectivity	5
2.4.3 Bluetooth Connectivity	5
2.4.4 GPS	6
2.5 Broadcasting	7
2.5.1 AM and FM Radio	7
2.5.2 Television Broadcast	8
2.6. Transmitter and Receiver Block Diagram	9
3 Software-Defined Radio	11
3.1 History	11
3.2 Architecture of Software Defined Radios	12
3.3 Advantages of Software Defined Radios	14
3.4 Popular Software Defined Radios	14
4. NI USRP Implementation	20
4.1 NI USRP Hardware	20
4.2 NI LabVIEW Communications System Design Software	21
4.3 Laboratory Exercise	22
Conclusion	23
References	24
Appendix 1 : Use of Radio Frequencies	26
Appendix 2: Labratory Set-up NI USRP	27
Appendix 3: Screenshot LabVIEW NXP	28

## **List of Abbreviations**

ADC	Analog to Digital Converters
AM	Amplitude Modulation
DAC	Digital to Analog Converters
DSP	Digital Signal Processors
GSM	Global System for Mobile Communications
IEEE	Institute of Electrical and Electronics Engineers
NI USRP	National Instruments Universal Software Radio Peripheral
PM	Phase Modulated
RF	Radio Frequency
SDR	Software Defined Radios
UHF	Ultra High Frequency
VHF	Very High Frequency

## 1 Introduction

One of the most interesting uses of electricity is to produce intangible energy ripples, namely radio waves. Following the accidental discovery of electromagnetism by Hans Oersted, it was discovered that the electricity and magnetism were interrelated. When a conductor passed an electric current, a magnetic field was produced perpendicular to the flow axis. Similarly, if a conductor was subjected to a perpendicular shift in magnetic flux to the conductor, a voltage was produced along the conductor's length. In the early 1800s, Joseph Henry, a professor at Princeton University, and the British physicist Michael Faraday, experimented separately with electromagnets. They also arrived at the same observation: the theory that a current in one wire, even at a distance, can generate a current in another wire. This phenomenon is known as electromagnetic induction, or simply induction. That is, one wire bearing a current causes a second wire to produce a current. So far, scientists have understood that, at right angles, electricity and magnetism have appeared to influence one another. A significant discovery, however, lay concealed just underneath this seemingly basic principle of linked perpendicularity and its unveiling was one of the seminal moments in modern sciences.

The term Software Radio was invented in 1991 by Joe Mitola. The purpose was to build a GSM base station. Software radios have a wide range of applications from amateur and home use to commercial and Military.

This report briefly tries to cover radio waves and their propagation through space, and the different techniques and devices used to transmit and receive signals and information using radio waves, and the relationship between the conventional radio and software defined radio – their basic difference, their advantage and disadvantages.

## 2 Radio Hardware

### 2.1 Radio Background and History

James Clerk Maxwell (1831–1879) discovered that electrical and magnetic fields were naturally connected to each other, with or without the presence of a conductive path for flowing electrons. More formally stated, this was Maxwell's discovery: a changing electric field generates a perpendicular magnetic field, and a shifting magnetic field generates a perpendicular electrical field. All of this may take place in open space, where the alternating electrical and magnetic fields assist each other as they pass at the speed of light through space. The complex system of spatially propagating electric and magnetic fields is best known as an electromagnetic wave. Earlier, the German physicist Heinrich Hertz, who is honoured by our substitution of the expression "cycles per second" with hertz (Hz), proved Maxwell's theory between 1886 and 1888. Shortly afterwards, in 1892, a French physicist, Edouard Branly, invented a device that could absorb radio waves and could trigger them to ring an electric bell. Remember that all the work performed at the time was done by physicists in what was to become radio and later radio-electronics. [1.]

### 2.2 Propagation of Radio Waves

There is a fixed relationship between frequency and wavelength, which is the distance of some form of wave between equivalent points on two opposite waves (Figure 1): sound (pressure), electromagnetic (radio) and light. The relationship is defined by the type of wave and the speed at which the wave-front passes through the medium. In higher density media, the propagation speed is slower. [1.]

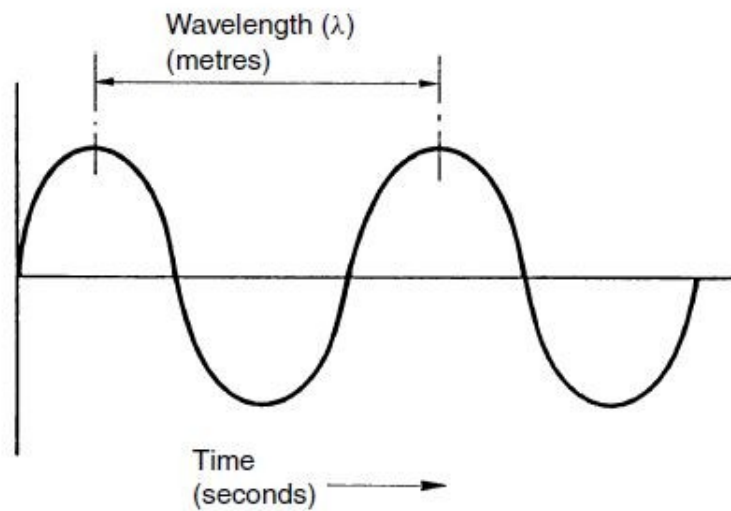

Figure 1. Frequency and Wavelength [1].

Sound waves propagate more slowly than radio and light waves that are travelling at the same speed, approximately 300,000 Km/s , in free space. And the relationship between a radio wave's frequency and wavelength is given by:

$$\lambda = \frac{3 \times 10^8}{f} \text{ meters} \quad (1)$$

where  $\lambda$  is the wavelength and  $f$  is the frequency in hertz (Hz). [1.]

### 2.3 The Radio Frequency Spectrum

Out of the electromagnetic wave spectrum, displayed in Figure 2, the portion which can be used for radio communication ranges from below 10 KHz to over 100 GHz [1].

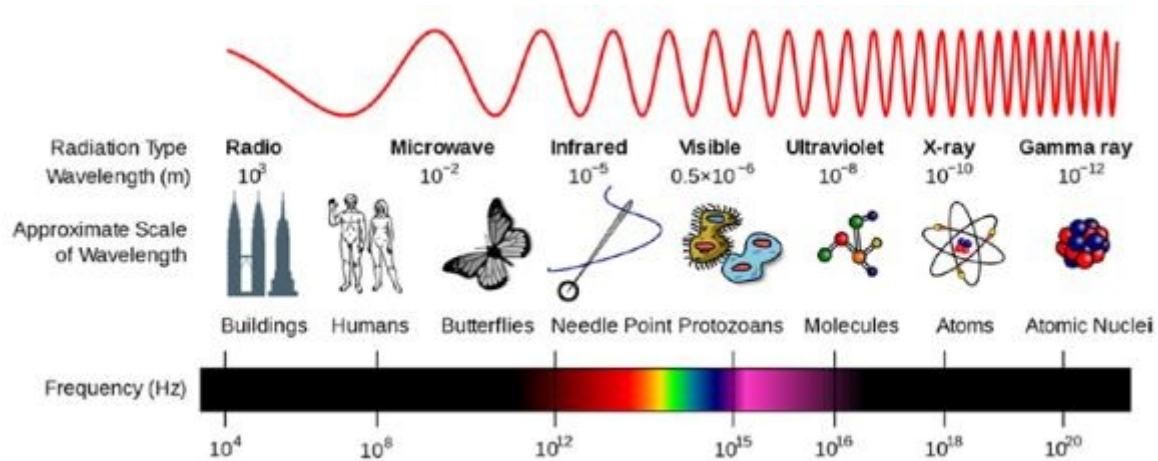

Figure 2. The electromagnetic wave spectrum [2].

The radio spectrum is divided into bands and band classification, key use and propagation method is shown in Appendix 1. Radio waves encompass a small portion of the vast electromagnetic spectrum. The waves of different frequencies behave differently, and this, along with the amount of spectrum available in each band for radio contact channels, determines their use. [2.]

## 2.4 Modern Radio Communication Systems

Radio waves come in handy when it comes to communication because they provide the opportunity to transmit information easily and able to propagate with a speed of light that is 300,000 Km/s [2].

### 2.4.1 Cellular Connectivity

Cell phones are one of the applications where radio waves are used. Each cell phone is connected to a cell tower and each tower exchange information with other towers about the location of the phone and the data to be transmitted. Figure 3 shows a cell tower. [2.]





Figure 3. A cell tower [2].

In the figure 3, the cell tower consists of high performance and high frequency antenna that are responsible to receive and transmit data to other cell towers [2].

#### 2.4.2 Wi-Fi Connectivity

Wi-Fi is a name given to a collection of wireless networking protocols. It is the fastest protocol that connects to and from a wired Ethernet connection. This type of connection functions with limited number of devices over a limited distance. Another interesting point to note is that Wi-Fi and Cellular connections in a cell phone can not use the same antenna because they operate at different frequencies. [2.]

#### 2.4.3 Bluetooth Connectivity

Bluetooth is a term given to describe a collection of standards for wireless communications. Bluetooth is mainly used to connect a main device such as a phone, or a computer to other peripheral devices for instance smartwatches and headphones. [2.]

This type of connectivity uses a relatively low power that made it preferable choice for battery powered devices. Bluetooth and Wi-Fi use same wireless frequencies and they often share antenna. [2.]

#### 2.4.4 GPS

GPS stands for Global Positioning System. It uses satellites to send time signals to the receivers on earth surface where the receivers are able to calculate their locations at any time as shown in Figure 4. [2.]



Figure 4. A computer rendering of a GPS satellite [2].

It is a one-way communication from the satellite to the receiver so that the receiver needs at least four satellites to calculate its location [2].

## 2.5 Broadcasting

Its a term given to a system of transmitter and receivers where radio signal will be sent out from a transmitter and one or many receivers pick up the transmission. The signal covers a large area and a long distance away from the transmitter. [2.]

### 2.5.1 AM and FM Radio

AM stands for " amplitude modulation " and FM stands for " frequency modulation ". They are methods of encoding information on a radio wave. Figures 5 and 6 consecutively show AM and FM signals. [2.]

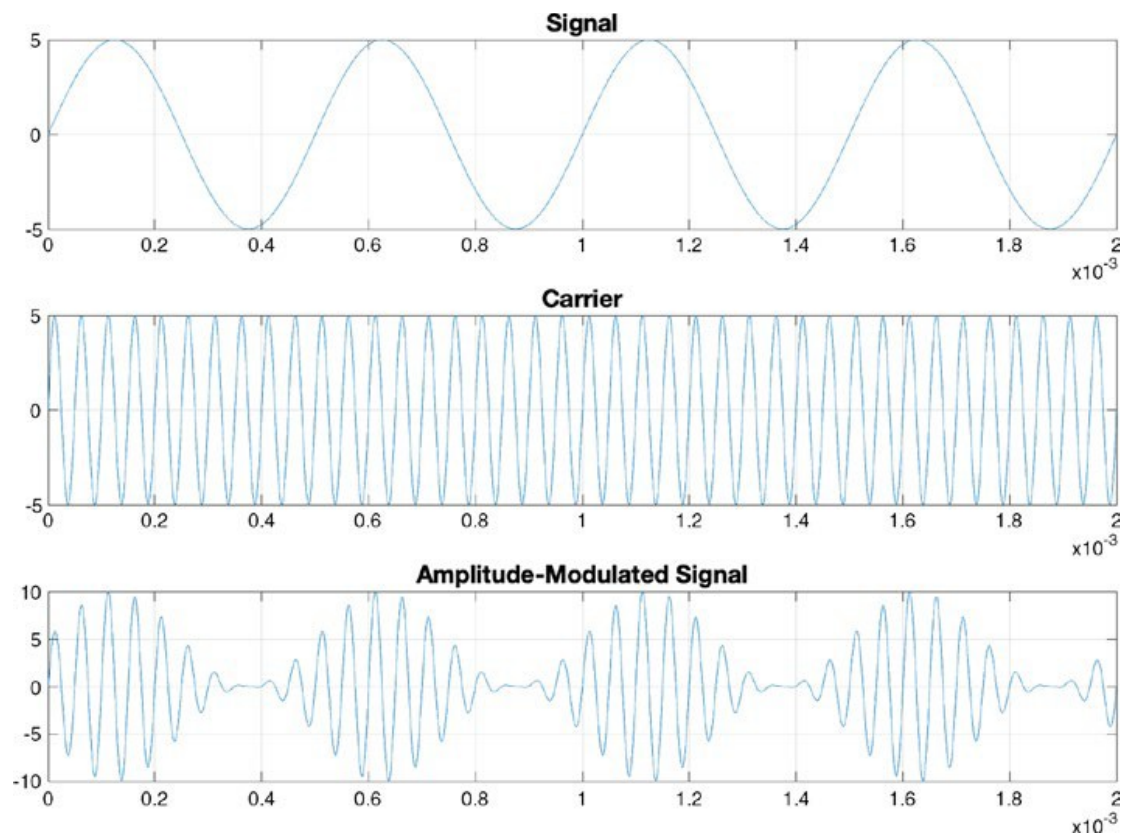

Figure 5. Amplitude modulation [2].

Figure 5 shows the appearance of an AM signal. The top is the signal, the middle is the carrier radio wave, both combine then create an AM signal. [2.]

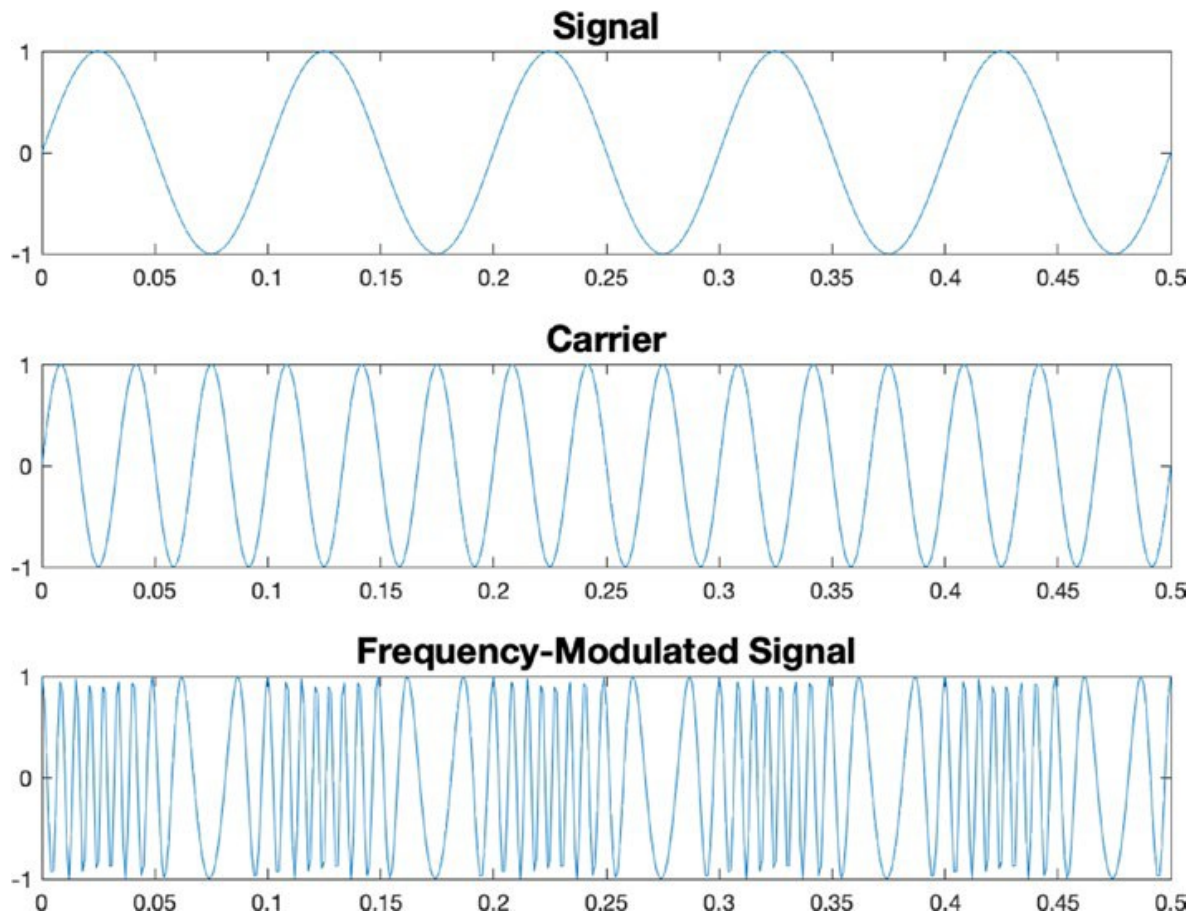

Figure 6. Frequency-modulated signal [2].

In Figure 6; the top is the signal, the middle is the carrier radio wave and the bottom is the FM modulated signal. When the amplitude of the signal increases, the carrier frequency increases. FM radio operates on higher bandwidth than AM radio, but AM radio propagates to farther distance. [2.]

### 2.5.2 Television Broadcast

Television broadcast has shown a trend of decline over recent years mainly due to the frequency range it holds in the electromagnetic spectrum has become very useful for communication purposes. Figure 7 shows a directional antenna to receive broadcasts. [2.]



Figure 7. Television signal receiving directional antenna [2].

Television broadcasts are still common in the present-day. At the same time cable transmission of television signals has become very popular as it offers higher quality, more channels and services. [2.]

## 2.6. Transmitter and Receiver Block Diagram

In hardware radio systems, Information is transmitted and received using electronic devices that consist of amplifiers, modulators, oscillators, and many more components. Figure 8 shows a block diagram of transmitter and receiver systems. The diagram more or less represents flow of information from source to destination over wireless network. The source can be a microphone, a video camera, or any sensor that converts different forms of energy into electrical signals. The source is indicated in block 1 in Figure 8. [3.]

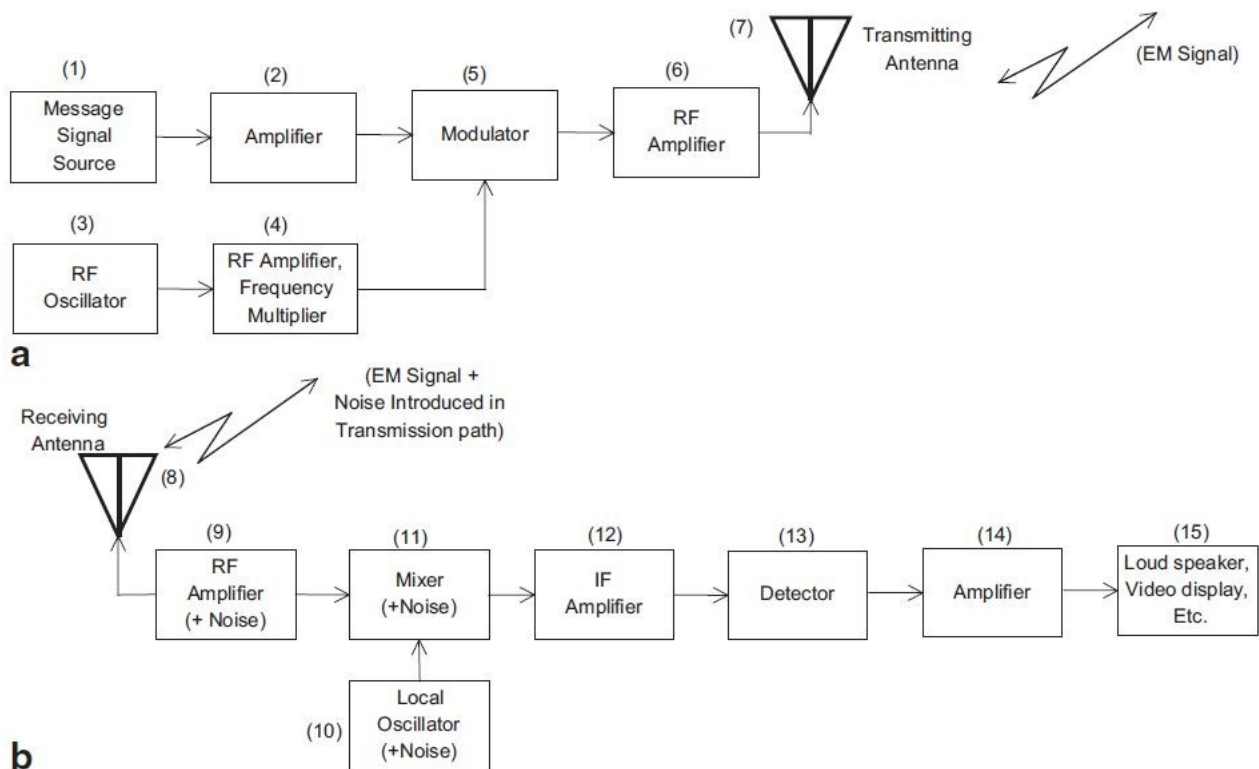

Figure 8. Block diagram of a transmitter (a) and a receiver(b) [3].

Information flow begins at the source (block 1). Electrical signal amplification takes place (block 2) and it is required that the signal needs to go through lowpass filter for bandwidth limitation. The RF oscillator (block 3) is responsible for generating carrier frequency. The RF amplifier and frequency multiplier (block 4) then takes the carrier frequency from block 3 to get the required frequency. The Modulator (block 5) takes in the inputs from the amplifier that gives the information signal and the carrier frequency. If a higher power level is required, an additional amplifier (block 6) is used and then sent out to be transmitted by the antenna (block 7). [3.]

The receiving end of the system then captures the signal by the receiving antenna (block 8) then the low voltage signal mixed with noise from the surrounding will enter the RF amplifier (block 9) because the low noise signal needs to get higher power level. This amplifier increases the amplitude of the incoming to surpass the noise that came with it. Then this signal will go to the mixer (block 11). Then the detector (block 13) will pick up the further amplified signal by the IF amplifier (block 12), at the same time the IF amplifier selects the desired signals. Finally the

extracted signal will further be amplified (block 14) and then sent to the output component to convert the signal to its original form before transmission. [3.]

### 3 Software-Defined Radio

#### 3.1 History

The concept of Software-Defined Radio (SDR) was first created in the 1970s–1980s by the joint efforts of a variety of study groups in US private and public organizations. The specific entities to be listed are the U.S. Department of Defense Facilities and the staff at E-Systems Inc. Garland, Texas District. In 1991, in conjunction with E-Systems, Joe Mitola independently reinvented the term 'Software Radio' (SR) as a method for creating a genuine GSM transceiver focused on software. Essentially, nearly all transceiver algorithms operate on the SR platform as a processor application that encompasses almost all transmission layers. Nonetheless, due to an immense amount of mathematical calculation an efficient design of the physical layer is often difficult. [4.]

The major difference between Software Defined Radios and traditional hardware based radios is that Software Defined Radios can be implemented for many frequency ranges and they come with much larger bandwidth[4]. A software is used to reconfigure at which frequency they are required to operate. For instance, the National Instruments product NI USRP 2900, shown in Figure 9, operates in a frequency range of 70MHz to 6GHz. [12.]



Figure 9. National Instruments Universal Software Radio Peripherals 2900 [5].

In Figure 9, the device was used in the electronics laboratory of Metropolia UAS at Myyrmäki campus. It is a product of National Instruments, having model name NI USRP 2900. It has physical dimensions (L x W x H) 12.5cm x 9.4cm x 3.8cm, and a weight of 676 grams. Some more of its specifications are summarized in table 1. [6.]

Table 1. Specifications of NI USRP 2900 [6]

<b>Transmitter</b>	
Frequency range	70 MHz to 6 GHz
Frequency step	< 1kHz
Maximum output power	20dBm
<b>Receiver</b>	
Frequency range	70MHz to 6 GHz
Frequency step	< 1kHz
Maximum input power	-15dBm

The development of Software Defined Radios offers a variety of excellent incentives for exploration and study. The fact that they are software defined enables the user to operate with a great deal of flexibility of frequency choice with larger bandwidth. That could be achieved by editing the code or changing the parameters on the software that is running the Software Defined Radio. [6.]

### 3.2 Architecture of Software Defined Radios

Superhetrodyne receivers are popular types of microwave receivers. They operate by mixing signals and taking the difference of the mixed frequencies that would make them desirable as they operate on low frequency hence cost becomes lower. Ideal Software Defined Radios also consist such receivers come with front-end hardware and a reconfigurable processor. As shown in figure 10 below, how the Software defined Radio approach is different from the traditional radio can be explained. It is a front end block diagram of superhetrodyne receiver. [7.]



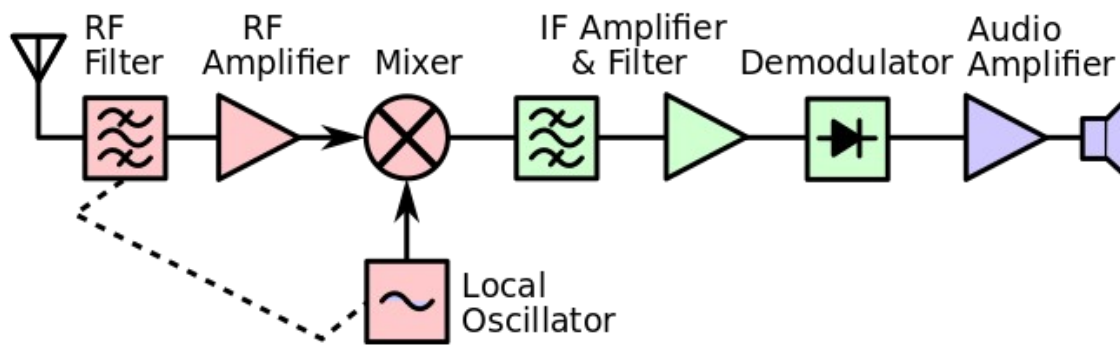

Figure 10. Block diagram of a superhetrodyne receiver [8].

The front end components are colored in red. The block diagram consists of components that process the signal at the original incoming radio frequency (RF), before it is converted to a lower intermediate frequency (IF). In the case of software defined radios, a basic block diagram is shown in figure 11.[ 8.]

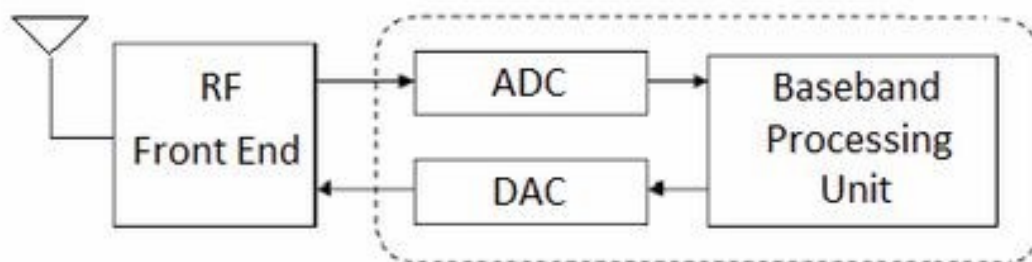

Figure 11. Block diagram of software defined radio [9].

As shown in figures 10 and 11, the components in figure 10 ( mixers, filters, modulators, and demodulators) are replaced by the ADC s and DAC s of the Software Defined Radio modules ( Figure 11). The baseband processing unit consists of FPGA s ( Field Programmable gate Array) to run multiple signal processing algorithms[9].The RF front ends in Software Defined Radios consist of Low Noise Amplifier and Analog-to-Digital conversion takes place after the amplifier. [10.]

### 3.3 Advantages of Software Defined Radios

Software Defined Radios present new era of radio communication in a way that they provide flexibility with frequency allocation and operation. Some of the advantages are listed below:

- *Interoperability:* Software Defined Radios can interact smoothly between several incompatible radios with their capability of being flexible and able to operate in many channels.
- *Lower Cost:* SDRs are applied in many sectors thus getting into many markets. For example in telecom sector and automotive applications. This versatility presents scalable cost efficiency.
- *Research and Development:* A real time analysis of different wave forms could be achieved by Software Defined Radios much faster and more efficient than simulations. [11.]

### 3.4 Popular Software Defined Radios

Some of the popular Software Defined Radios of 2020 are listed below:

#### 1. HackRF One SDR:

This SDR is able to operate in a frequency range of 1 MHz to 6 GHz. It is open source and could be used with a computer software controlling it or it could be configured for stand-alone purposes. Shown in Figure 12 is a HackRF one device. [12.]



Figure 12. HackRF one [12].

Some more specifications of the HackRF one are:

- Hi speed USB 2.0
- software-controlled antenna
- it can process upto 20 million samples per second

## 2. Yard Stick One USB Transceiver and 915 Mhz Antenna

YARD stands for Yet Another Radio Dongle. It is shown in Figure 13.



Figure 13. YARD dongle [12].

This dongle is able to transmit and receive in half-duplex system. It operates in a frequency range of 300-348 MHz, 391- 464MHz, and 782- 928 Mhz with data rates reaching 500kbps ( kilobits per second ). [12.]

## 3. Seeedstudio KiwiDR Kit SDR

KiwiSDR is another radio that is able to cover shortwave, longwave, AM bands, Different stations and amateur radio globally. It is shown in Figure 14. [12.]



Figure 14. Seedstudio KiwiSDR[12].

This SDR operates in the frequency range of 10KHz to 30MHz. It presents higher degree of flexibility for the user so that it can run on a software from micro-SD card, and with an antenna and a network connection it is easy to use. Users can listen to Shortwave, Longwave, and AM transmissions by tuning simultaneously to different frequencies. [12.]

#### 4. NESDR Mini 2+ 0.5PPM TCXO RTL-SDR and ADS\_B USB Receiver

This SDR is a Japanese made module. It has telescopic antenna, for a cheap price with a possibility of achieving tasks such as fire scanning, amateur radio, and many other activities that could be done by other SDRs. Figure 15 shows the SDR module with the antenna. [12.]



Figure 15. NESDR Mini 2+ [12].



Figure 17. RTL-SDR software defined radio [12].

This SDR is best suited for air traffic control, radio astronomy. Its outer shield protects the circuitry from ESD (Electro Static Discharges). [12.]

#### 7. Ham It Up v1.3

This module is compatible with common Software Defined Radio platforms to create HAM radio. Figure 18 shows the module. [12.]



Figure 18. Ham It Up v 1.3 Up converter [12].

Listening to MF and HF through existing SDR would be possible using this module.

#### 8. NESDR Nano 3 OTG

This SDR module is compatible with many computer operating systems, namely Windows, Mac OSX, Linux. Figure 19 shows the SDR module. [12.]



Figure 19. NESDR Nano3 [12].

This SDR operates in a frequency range from 25MHz to 1700MHz. The accessories included will give possibility to install the SDR in different ways. [12.]

#### 9. NESDR SMARt HF Bundle

This bundle makes use of the Ham It Up Upconverter to capture HF. Figure 20 shows the Bundle. It operates between 100kHz and 1.7GHz. [12.]



Figure 20. NESDR SMARt [12].

## 4. NI USRP Implementation

### 4.1 NI USRP Hardware

Software Defined Radio (SDR) refers to the technology used to execute radio functions with software modules operating on a standardized hardware platform. By combining the NI USRP hardware with LabVIEW software, a versatile and usable SDR framework for fast prototyping of wireless signals could be built including physical layer design, recording and playback, signal intelligence, algorithm validation, and more. The NI USRP connects to a host PC which creates a radio specified by the program. Using a direct-conversion receiver to baseband I / Q modules, incoming signals at the SMA connector inputs are mixed down, sampled by an analog-to-digital converter (ADC). For transmission, host device synthesizes baseband I / Q signal samples and is fed to the USRP at a specified sample rate over Ethernet, USB, or PCI express. Using a digital upconversion (DUC) device, the USRP hardware interpolates the incoming signal to a higher sampling rate, and then converts the signal to analog with a digital-to-analog converter (DAC). The resulting analog signal is then blended to the required frequency of the carrier. [13.]

The NI USRP hardware could be briefly explained in the block diagram shown in figure 21.

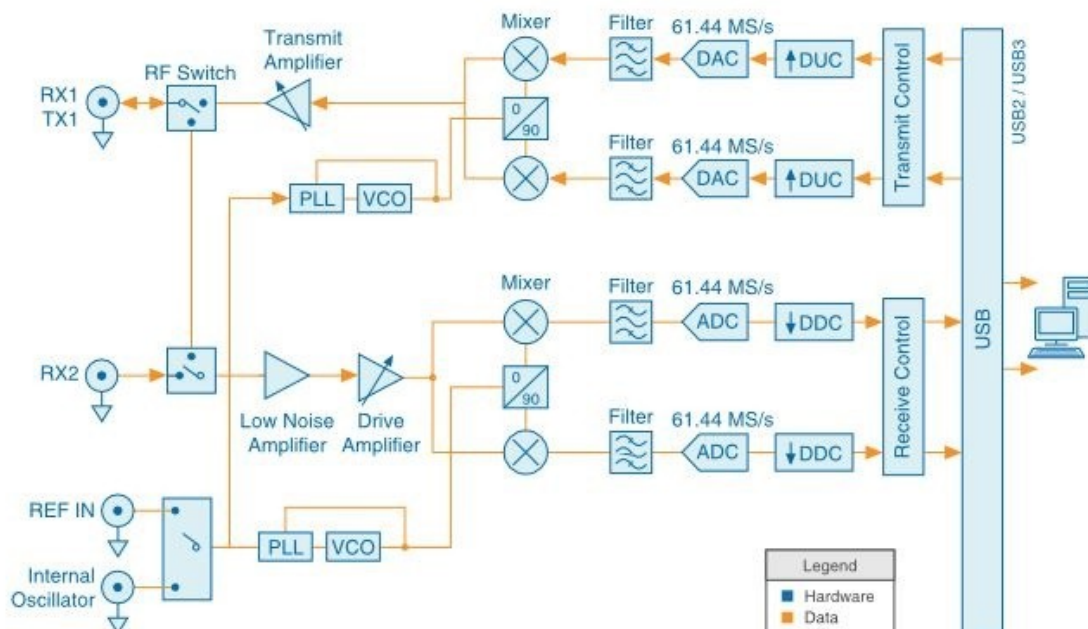

Figure 21. NI USRP 2900 hardware block diagram [14].



In the above figure, the NI USRP hardware consists mainly of the Transmit path and the Receive path. And in each path there are Mixers, Filters, Amplifiers, and different controls.

#### 4.2 NI LabVIEW Communications System Design Software

LabVIEW NXG is a language developed by National Instruments for graphical programming. LabVIEW NXG's baseline building block is the virtual instrument (VI). In traditional programming languages a VI is conceptually equivalent to a process or function. Each VI is composed of a block diagram and a front panel. The block diagram defines the VI's features, while the front panel is the VI's top level graphical user interface. The VI build brings two essential LabVIEW NXG virtues: code reuse and modularity. LabVIEW's graphical nature offers another virtue: it helps developers to quickly visualize the data flow in their designs. Since LabVIEW NXG is a mature programming language for data flows, it also has a wealth of existing documentation, toolkits, and examples that can be leveraged in development. [13.]

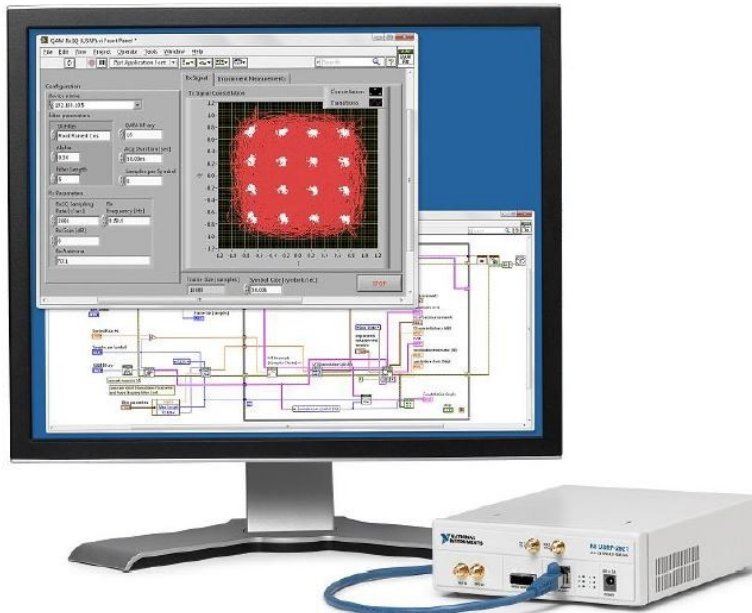

Figure 22. Hardware setup in a wireless communications Laboratory [13].

LabVIEW NXG offers a simple interface for the setup and control of various external I / Os like the lab-based NI SDR hardware. [13.]

### 4.3 Laboratory Exercise

The NI USRP 2900 device was used for the experiment, which has got similar specifications as NI-USRP 2901 covering a frequency range from 70MHz to 6GHz. This particular frequency range covers FM frequencies to WiFi transmissions. This range covers many applications but there are more USRP s with more expensive price that come with larger Bandwidth. The USRP 2900 was set up at Metropolia UAS Myyrmäki campus in electronics laboratory. [13.]

The aim was to conduct a number of exercises using the setup shown in Appendix 2. In this report, only one exercise was achieved. The exercise involved setting up the device, connecting the Transmitter port (Tx) with the Receiver port (Rx) using the provided loopback cable and a 30dB attenuator. The main reason for such connection was of the concern of unauthorized transmission could leak out. Otherwise an antenna on the transmitter and receiver ports would have been placed. Appendix 3 shows a screen shot taken from a computer running LabVIEW NXG and USRP 2900 connected to it. Signal was sent from the transmitter to the receiver via the loopback cable. Figure 13 below shows the LabVIEW NXG block diagram of the receiver program. [13.]

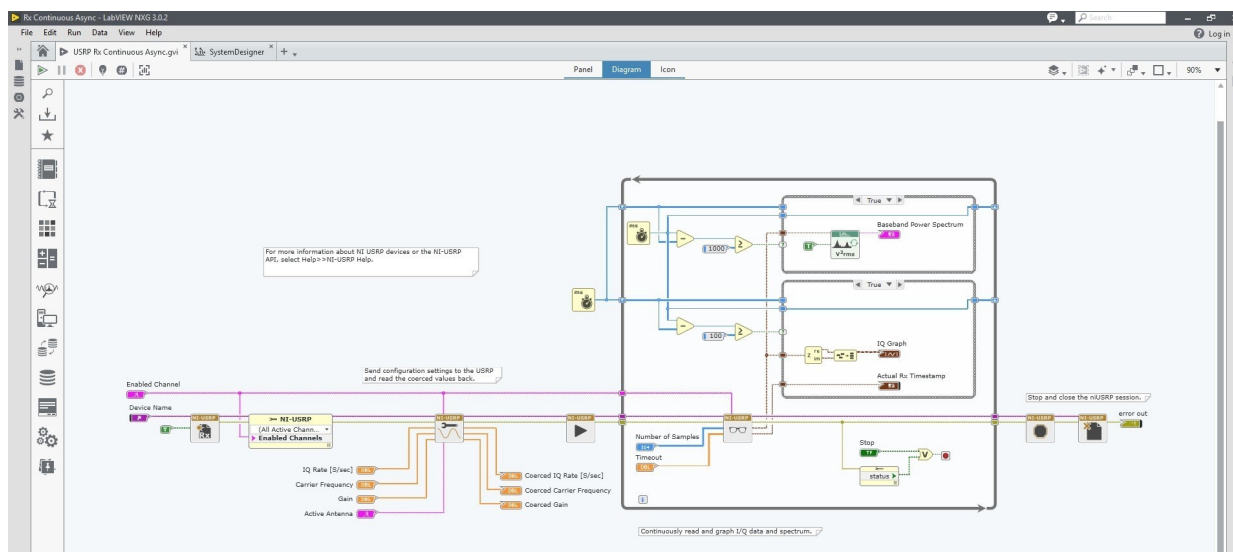

Figure 23. Rx block diagram

## **Conclusion**

The report describes the evolution of the radio from the traditional hardware radio, the early days of radio, the behaviour of radio waves and some concepts about electromagnetic waves are mentioned.

The study tried to explain about Software defined radios. The history of Software defined radios and their evolution have been covered. In the study, some of the most benefits of Software defined radios; such as the ability of Software Defined Radios to interact between several incompatible radios, the opportunity they present for various economic sectors to save cost.

The performed laboratory exercise is also part of this report. It involved connecting the NI USRP 2900 hardware and a computer with LabVIEW NXG installed. The transmitter and receiver ports were connected by loopback cable to prevent any signal broadcast to the outside. Overall the study was very short compared to the width and depth of the topics discussed, but this thesis could be used as a material for other topics related to software defined radios.

## References

1. Winder S, Carr J. Radio and RF Engineering Pocket Book. 3<sup>rd</sup> edition. Oxford: Jordan Hill; 2002
2. Wulff A, Beginning Radio Communications : Radio Projects and Theory. Cambridge, MA, USA ; 2019
3. Pontes J, Strum C, De Los Santos H. Radio Systems Engineering. Springer Cham Heidelberg London; 2015
4. Haykin S. Cognitive Radio: Brain-Empowered Wireless Communications. Sel Areas Commun. 2005
5. Asennusohje National Instruments USRP-2900-ohjelmistoradiolaitteelle [Online]  
URL: <http://www.ee.oulu.fi/~kk/Asennusohje%20USRP-2900-laitteelle.pdf>
6. USRP-2900 [Online]  
URL: <https://www.ni.com/pdf/manuals/374924c.pdf>  
Accessed on May 26, 2020
7. Pollin S, Timmers M, Van der Perre L. Software Defined Radios From Smart(er) to Cognitive. NewYork; 2011
8. RF front end [Online]  
URL: [https://www.wikiwand.com/en/RF\\_front\\_end#/citenoteCarr1](https://www.wikiwand.com/en/RF_front_end#/citenoteCarr1)  
Accessed on May 02,2020
9. What is Software Defined Radio? [Online]  
URL: <https://www.everythingrf.com/community/what-is-a-software-defined-radio>  
Accessed on May 27, 2020
10. Gianni V, Graninckx J, Baschiroto A. Baseband Analog Circuits for Software Defined Radio. Springer; 2008
11. Grayver E. Implementing Software Defined Radio. Springer New York; 2013

12. Popular Software Defined Radios [ Online]

URL: <https://blog.bliley.com/10-popular-software-defined-radios-sdr>

Accessed on May 27,2020

13. Black B. Introduction to Communication Systems: Lab Based Learning with NI USRP and Labview Communications. Austin, Texas; 2014

14. USRP Software Defined Radio Device Manual. [Online]

URL: <https://www.ni.com/documentation/en/usrp-software-defined-radio-device/latest/usrp-2900/block-diagram/>

Accessed on May 02,2020

## Appendix 1 : Use of Radio Frequencies [1]

**Table 1.1** Use of radio frequencies

<i>Frequency band</i>	<i>Designation, use and propagation</i>
3–30 kHz	Very low frequency (VLF). Worldwide and long distance communications. Navigation. Submarine communications. Surface wave.
30–300 kHz	Low frequency (LF). Long distance communications, time and frequency standard stations, long-wave broadcasting. Ground wave.
300–3000 kHz	Medium frequency (MF) or medium wave (MW). Medium-wave local and regional broadcasting. Marine communications. Ground wave.
3–30 MHz	High frequency (HF). ‘Short-wave’ bands. Long distance communications and short-wave broadcasting. Ionospheric sky wave.
30–300 MHz	Very high frequency (VHF). Short range and mobile communications, television and FM broadcasting. Sound broadcasting. Space wave.
300–3000 MHz	Ultra high frequency (UHF). Short range and mobile communications. Television broadcasting. Point-to-point links. Space wave. Note: The usual practice in the USA is to designate 300–1000 MHz as ‘UHF’ and above 1000 MHz as ‘microwaves’.
3–30 GHz	Microwave or super high frequency (SHF). Point-to-point links, radar, satellite communications. Space wave.
Above 30 GHz	Extra high frequency (EHF). Inter-satellite and micro-cellular radio-telephone. Space wave.

# Appendix 2: Laboratory Set-up NI USRP



### Appendix 3: Screenshot LabVIEW NXP

Receiver panel Rx

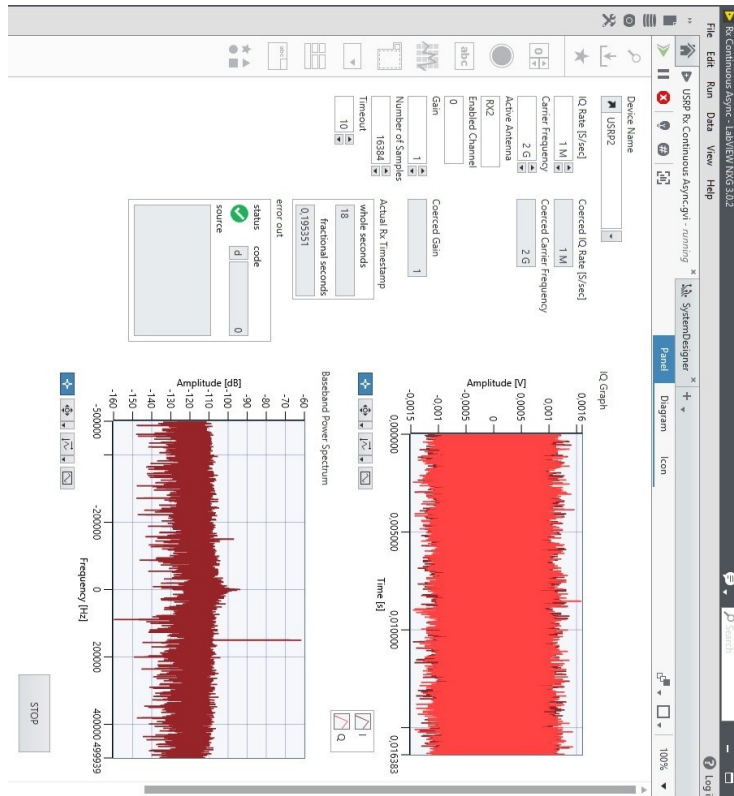

Transmitter Panel Tx

