

UNIVERSIDADE DE LISBOA
FACULDADE DE CIÊNCIAS
DEPARTAMENTO DE ENGENHARIA GEOGRÁFICA, GEOFÍSICA E ENERGIA



A new concept in compressed air energy storage

João Paulo Mendes da Silva

Versão pública

Dissertação de Mestrado Integrado em Engenharia da Energia e do Ambiente

2014

UNIVERSIDADE DE LISBOA
FACULDADE DE CIÊNCIAS
DEPARTAMENTO DE ENGENHARIA GEOGRÁFICA, GEOFÍSICA E ENERGIA



A new concept in compressed air energy storage

João Paulo Mendes da Silva

Dissertação de Mestrado Integrado em Engenharia da Energia e do Ambiente

Trabalho realizado sob a supervisão de:

Miguel Oliveira Panão (FCTUC)

Jorge Maia Alves (FCUL)

2014

Abstract

The aim of this master thesis is to explore a new concept in energy storage, the liquid assisted compressed air energy storage (LACAES). Several other energy storage technologies were briefly reviewed to set a comparative basis for LACAES. The fundamentals of compressed air energy storage (CAES) are explained, and an essential introduction to LACAES is made, emphasizing the advantages of LACAES over conventional CAES. From this comparison the most promising applications for LACAES technology are chosen. For one of the applications, in the field of human generated and stored power, an early prototype, named KeepIt™ is built and tested. The efficiency of the system, the possibility of power output control and the performance of crucial components are evaluated.

Although KeepIt™ early prototype had a maximum efficiency of about 7 %, the guidelines for further development are well defined and great improvements on the performance are foreseen in future work.

Resumo

O objectivo desta tese de mestrado foi a de explorar o conceito da tecnologia de armazenamento de energia por ar comprimido assistida por líquido (LACAES).

O armazenamento de energia tem um papel cada vez mais importante em sistemas de energia, desde armazenamento para a rede e mobilidade eléctrica, as aplicações são imensas. Isto manifesta-se numa expectativa de crescimento de mercado em 10 vezes da actual dimensão em 2018 (Miller, 2014). Este crescimento tem vindo a alimentar um crescimento de investigação nas áreas de armazenamento por ar comprimido (CAES) devido às suas características promissoras (Najjar u. Zamout, 1998). Ainda assim o CAES não é ainda uma solução competitiva para o mercado, essencialmente porque requer a queima de gás natural para compensar as ineficiências do armazenamento.

A tecnologia LACAES vem resolver as ineficiências existentes no CAES com a introdução de compressões e expansões isotérmicas. Nesta tese, tecnologias de armazenamento de energia são revistas em síntese e, posteriormente, comparadas com LACAES. Os fundamentos da tecnologia de armazenamento de energia com ar comprimido (CAES) são apresentados. As vantagens de LACAES sobre CAES são apresentadas e a LACAES é explicada. Desta comparação determinam-se as melhores aplicações para a tecnologia LACAES. Para a aplicação de produção e armazenamento de energia por esforço humano, um protótipo designado por *KeepIt*TM é construído e testado. Testou-se a eficiência deste sistema, a eficácia do sistema de controlo de potência e o desempenho de componentes essenciais.

Ainda que o protótipo *KeepIt*TM tenha uma eficiência de cerca de 7 %, os melhoramentos necessários são descritos e uma grande melhoria na eficiência está prevista em trabalho futuro.

Contents

Table of contents	i
Glossary	ii
List of Figures	iv
1 Introduction	1
2 State of the art	3
2.1 Electrochemical energy storage	3
2.2 Gravitational potential energy storage	4
2.3 Thermal energy storage	5
3 Compressed air thermodynamics	6
4 Liquid assisted compressed air energy storage	10
5 Applications	11
5.1 Human scale: KeepIt Rural electrification	11
5.1.1 Existing solutions	12
5.1.2 KeepIt™, a LACAES solution	12
6 KeepIt™Proof-of-Concept Prototype	14
7 Conclusions and future work	15
Bibliography	17

Glossary

Symbol and Unit

Symbol	Description	Unit
A	Area	m^2
c	Specific Heat Capacity	$J K^{-1}$
E	Electrode potential	V
E_p	Potential energy	J
g	Earth's gravitational acceleration	$m s^{-2}$
h	height	m
L	Latent heat	$J kg^{-1}$
m	mass	kg
n	Number of moles	mol
k	Adiabatic constant	
P	Power	$J s^{-1}$
p	Pressure	Pa
W	Work	J
Q	Thermal energy	J
R	Ideal gas constant $R=8.31$	$J K^{-1} mol^{-1}$
r_p	Pressure ratio	
T	Temperature	K
U	Gravitational potential energy	J
V	Volume	m^3
v	Speed	$m s^{-1}$

Greek Symbols

Symbol	Description	Unit
ρ	Mass density	kgm^{-3}
η	Efficiency	%
Δ	Difference	

Indices and Abbreviations

Symbol	Description
eq	Equivalent
iso	Isothermal
adi	Adiabatic
ef	Effective
int	Internal
oc	Open circuit
sc	Short circuit

Initialisms and acronyms

Symbol	Description
CAES	Compressed air energy storage
DoD	Depth of discharge
LACAES	Liquid assisted compressed air energy storage
RPM	Rotations per minute
PCD	Pitch circle diameter

List of Figures

- 2.1 Typical Li-ion battery cell. Adapted from (IEC, 2011) 4

- 3.1 Effect of pressure ratio for an expansion process ($0 < r_p < 1$) on the ratio between the work performed by isothermal and adiabatic processes. 8
- 3.2 Schematics of a small scale CAES system with thermal storage instead of gas burning. Adapted from (Jannelli u. a., 2014) 9

- 5.1 KeepIt™early prototype. Adapted from (Séneca, 2014) 13

1 Introduction

Energy storage is playing an increasing role in modern power systems. From grid storage to electric mobility the applications are numerous. This is expressed in a fast increasing market, expected to grow 10 times its current size by 2018 (Miller, 2014). This growth is strongly supported by an increasing share of renewable energy sources in the electric grid and the consequent need for load management (Lund u. Salgi, 2007).

This increases the interest in the development of energy storage technologies. Compressed air energy storage mixed with gas generated energy has received great attention due to its attractive economical and technical feasibility (Najjar u. Zaamout, 1998). Nonetheless, this is a technology based on an inefficient process to store energy (CAES) which is compensated by the consumption of natural gas. CAES can be made more competitive as an energy storage technology by assisting the compressed air energy storage with a liquid (LACAES - Liquid Assisted Compression Air Energy Storage), thus improving CAES by introducing isothermal expansion and compression. The main objective of this thesis is to explore the concept of LACAES. This implies the development and testing of a prototype.

After these introductory remarks, a brief review of several energy storage technologies is made, in terms of their fundamentals and predominant applications of each technology. A greater attention to CAES is given due to its close relation to LACAES. The fundamental thermodynamics behind CAES, which is essentially the same for LACAES, is explained and the disadvantages of each approach are discussed. A broader presentation of LACAES is made including the basics of some of the components involved in the LACAES system setup.

The best applications for LACAES are presented. For a human powered application, a great attention is given to the design for satisfying the needs of users in developing countries with no access to electricity, due to the market size and the social character of this type of application (Stiftung Solarenergie Solar Energy Foundation). Therefore, the LACAES prototype is built with the human powered off-grid product in mind. Chapter 6 is dedicated to describe the product components and assembly. The performance of the most relevant components is assessed and characterized. A power control method is introduced and its effectiveness is tested. A functional version of the prototype is tested, and its overall efficiency is determined.

In conclusion, the power control method shows to be effective. Components used for the assembly are inappropriate and result in a low system efficiency. Improvements to the system's efficiency are

presented along with clear guidelines for their implementation in future work.

2 State of the art

In this chapter, technologies for energy storage are briefly reviewed. The physics behind these technologies are explained, as well as their major advantages and disadvantages. Compressed air energy storage is not presented here since there is a dedicated chapter on this technology.

2.1 Electrochemical energy storage

Electricity is the flow of electrons in a conductive material. The movement of those electrons depends on an electromotive force acting in the material. This electromotive force can be produced via different electrode potentials, as in the case of batteries.

The battery is composed of electrodes and an electrolyte. When the anode oxidation occurs, electrons are released from the electrode and cations dissolve in the solution. The released electrons will flow through the conductor and reach the cathode, where the reduction occurs. There, an anion will receive the electron, reduce and precipitate. The voltage is determined by the difference in potential of redox reactions. $E_{cell} = E_{cathode} - E_{anode}$.

Batteries used for grid energy storage have high round-trip efficiencies, namely, 80 to 90% for those based on lead-acid and 95 to 98% for lithium. Batteries are expensive and accidents present a serious environmental risk, especially with lead-acid batteries (IEC, 2011). Lead-acid batteries have a typical life-time of up to 1500 cycles at 80% depth of discharge (DoD) (IEC, 2011), while Li-ion batteries (see example in Fig. 2.1) can have a cycle life of up to 4700 cycles with 10% DoD (Buchmann, 2003).

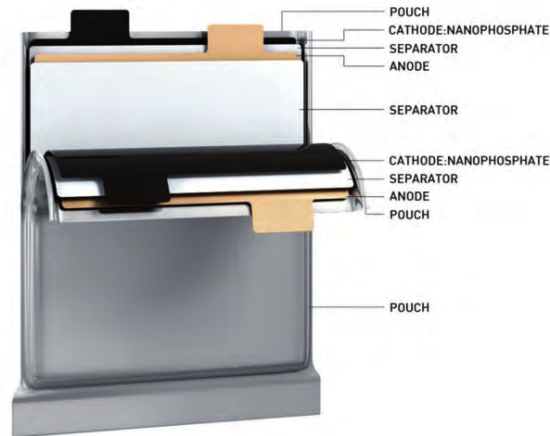

Figure 2.1: Typical Li-ion battery cell. Adapted from (IEC, 2011)

2.2 Gravitational potential energy storage

Earth's gravitational field produces a force able to perform work. This potential energy represents all the work that the weight force can perform on a certain mass (m) at a certain height (h). Potential energy is calculated with $\Delta E_p = mgh$, where g corresponds to Earth's gravitational acceleration. In the cases where energy transfer is isothermal and variations in the kinetic energy are negligible, according to an energy balance, Work corresponds to the difference in the gravitational potential energy at the different heights, and is expressed as:

$$W = \Delta E_p = mgh_1 - mgh_2 = mg \times dh \quad (2.1)$$

This is a way of storing energy. Work is required to elevate a mass to a certain departure height, and later this mass can perform work while returning to the lower potential. These systems are simple but have a low energy density. The energy density (per unit mass, $J kg^{-1}$) results in:

$$\frac{\Delta E_p}{m} = g \times dh \quad (2.2)$$

Since the gravitational acceleration is constant, energy density is simply a linear function of height difference (head). Systems with a higher level difference represent a great technical challenge, so the usual solution is a very large amount of mass in order to store significant amounts of energy.

Despite their low energy density, gravitational potential energy storage is quite common. Reversible dams store water in very large reservoirs at a relative low head. The pressure of the water column at

turbine level is given by $p = \rho \times g \times h$. The height (h) is the depth of the water reservoir. The mass of water at high pressure that flows through the turbine, which is connected to a generator, produces electrical energy from the work developed and calculated according to eq. 2.1. Higher heads correspond to higher energy density, Pelton turbines are used as the proper turbine for working with high heads, they are very efficient turbines with efficiencies up to 92% (Thake, 2000).

Pumped hydro energy storage has a high round trip efficiency between 70 and 85%. It is the most common and mature form of energy storage. Dams require specific geographical conditions, tend to be expensive and have relevant environmental impacts (Lindley, 2010).

2.3 Thermal energy storage

Heat engines convert heat into work using a thermodynamic cycle that transports thermal energy from a heat source, at high temperature, to an heat sink, at lower temperature. Concentrated solar power plants focus sun light to produce heat, this heat is then used to produce electricity. Heat can then be stored and electricity produced even when there is no sunlight (IEC, 2011).

The amount of thermal energy that can be extracted from hot a mass depends on the material specific heat and the temperature difference as:

$$Q = m \times c \times \Delta T \quad (2.3)$$

This equation shows that, even if one uses a material like water, with a high specific heat of $c = 4186 \text{ J kg}^{-1} \text{ K}^{-1}$, to store energy, a big temperature difference is needed. The conclusion is that sensible heat is not the better way to store energy, the right choice being latent heat, the heat associated to a phase change at constant temperature. The amount of heat that can be stored using latent heat can be calculated from the amount of mass that suffers a phase change (Δm) times the specific latent heat (L), as:

$$Q = \Delta m \times L \quad (2.4)$$

The latent heat of fusion of water is $L = 3.33 \times 10^5 \text{ J kg}^{-1}$, roughly 80 times more than the water's specific heat.

Thermal energy storage is low-cost and presents a low environmental risk. Latent heat thermal storage is typically used in solar thermal power plants to store heat from the sun, instead of converting electricity into heat, for operation without sun light. Special phase-change salts are used to store latent heat (IEC, 2011).

3 Compressed air thermodynamics

Energy can be stored in the form of compressed air, but air can be compressed and expanded through several processes. Different thermodynamic processes result in different final conditions of pressure, volume and temperature, two of these parameters defining a state of dry air. Therefore, the same mass of air can go through different states, depending on the process, resulting in different values for the work performed. The conditions used dictate the nature of the processes and their applicability for energy storage systems. Thus, it is important to understand which processes are more adequate for energy storage applications.

Compressed air energy storage (CAES) is essentially a thermodynamic process where energy can be stored and extracted as work. In an adiabatic process the energy stored during compression depends on the work performed. This latter can be calculated from the integration of pressure over the variation of volume as:

$$W = - \int p dV \quad (3.1)$$

The pressure during expansion or compression changes according to the nature of the thermodynamic process. Typically, CAES consists of adiabatic compressions and expansions, where the gas does not exchange heat with the surroundings because the volume variation is too fast or the gas is thermally well isolated. Therefore, assuming a polytropic behavior for the gas during the adiabatic process, the relation between pressure and volume is given by:

$$p \cdot V^k = \text{constant} \quad (3.2)$$

Applying eq. (3.2) in (3.1), the work in an adiabatic process of compression, or expansion, between equilibrium states 1 and 2, is given by

$$W_{adi} = \frac{p_1 V_1 - p_2 V_2}{1 - k} \quad (3.3)$$

where p_n stands for the absolute pressure, and V_n for the volume in the thermodynamic state n .

Processes can also be isothermal, maintaining the gas temperature constant during compression or expansion. This means that the process timescale is sufficiently low, in order to allow a heat

exchange with the surrounding environment, or else the heat exchanged is enhanced in faster processes. In this case, assuming the gas behaves as an ideal one, the equation of state can be used to represent the isothermal expansion and compression as:

$$p \times V = nRT \quad (3.4)$$

So

$$p = \frac{nRT}{V} \quad (3.5)$$

In the case of isothermal expansion or compression, the work is calculated as

$$W_{iso} = nRT \times \ln \frac{p_2}{p_1} \quad (3.6)$$

In conventional CAES, isothermal expansions are not achieved, although some attempts have been made through heating the expanded gas, implying the combustion of fuel and, consequently, the corresponding emission of pollutants to the atmosphere (Grazzini u. Milazzo, 2008).

A comparison can be made to evaluate the difference between adiabatic and isothermal processes, in order to understand which would be more efficient. Considering two pressurized systems with a common initial state of p_1 , V_1 and T_1 , and that both will expand to a common final pressure (p_2). Considering the pressure ratio between the final and initial values as $r_p = \frac{p_2}{p_1}$, the work can be calculated rewriting equations (3.6) and (3.3) to include only p_1 , V_1 and r_p .

$$W_{iso} = p_1 V_1 \times \ln(r_p) \quad (3.7)$$

and

$$W_{adi} = p_1 V_1 \times \frac{1 - r_p^{1-\frac{1}{k}}}{1 - k} \quad (3.8)$$

For $0 < r_p < 1$ there is an expansion and work is extracted ($W < 0$). For $r_p > 1$, work is performed on the system through a compression process ($W > 0$). The difference between processes during expansion, where work is produced to generate electricity, is better perceived by plotting $\frac{W_{iso}}{W_{adi}}$ as a function of $r_p \in [0, 1]$.

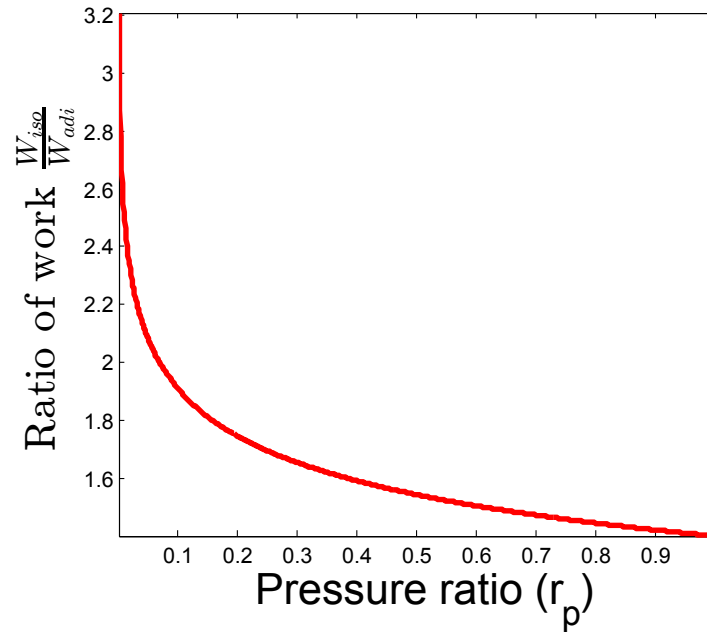

Figure 3.1: Effect of pressure ratio for an expansion process ($0 < r_p < 1$) on the ratio between the work performed by isothermal and adiabatic processes.

For an expansion, the isothermal process is more energetic, especially for $r_p < 0.1$, which is the case for CAES (Najjar u. Zaamout, 1998). Therefore, this is a motivation for developing a system capable of storing energy with isothermal compression and expansion.

Conventional CAES power plants work with adiabatic compression and expansion. As a result of the adiabatic compression, the gas temperature increases from ambient temperature (T_A) to a final temperature (T_B). According to the polytropic process from p_A to a final pressure $p_B = r_p \times p_A$, T_B is given by:

$$T_B = T_A \left(\frac{r_p \times p_A}{p_A} \right)^{1 - \frac{1}{k}} = T_A \times r_p^{1 - \frac{1}{k}} \quad (3.9)$$

Air that is stored at a higher temperature than the surroundings, with time, will cool toward ambient temperature (T_A). This cooling represents a major loss of internal energy, an energy that will not be recovered during expansion (discharging) (Lindley, 2010).

Still CAES plants exist, but they rely on a combination of energy storage and thermoelectric energy production. Because heat losses are significant, CAES power plants burn gas to heat the expanding air, in order to mitigate the energy losses. Typical overall efficiency for gas fired CAES is around 47%, requiring 0.75 kWh in compressing air plus 1.17 kWh from gas burning for every kWh of generated electricity (Najjar u. Zaamout, 1998).

For a small scale CAES that relies solely on compressed air storage and a pressure ratio of $r_p = 35$, an efficiency of 57% can be obtained (Jannelli u. a., 2014). This efficiency is achieved by an additional storage of the wasted heat during adiabatic compression, returning it during expansion (As seen in the CAES example depicted in Fig. 3.2), where the compression and expansion are performed in several stages using heat exchangers (Jannelli u. a., 2014).

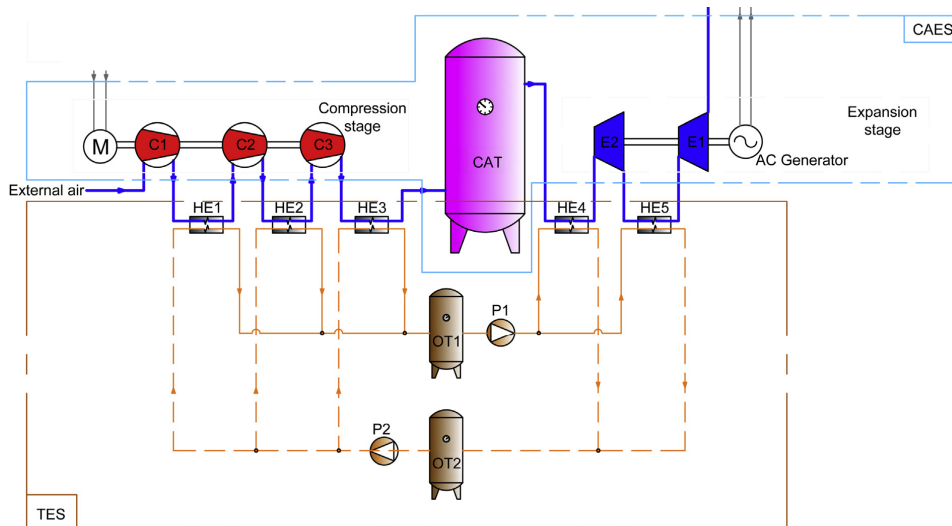

Figure 3.2: Schematics of a small scale CAES system with thermal storage instead of gas burning. Adapted from (Jannelli u. a., 2014)

The next chapter is dedicated to the development of the fundamental thermodynamics associated with a CAES system modified by assisting it with a liquid. This is the underlying physics that is further implemented in a prototype system that constitutes the main research work described in this thesis.

4 Liquid assisted compressed air energy storage

Conteúdo confidencial (7 páginas)

5 Applications

Energy storage will be the bottle neck in a world mainly driven by renewable energy sources. Solving the problem of renewable energy dispatchability is what will allow for the integral shift to this type of energy. Fossil fuels will be reserved for applications that cannot avoid it. Recent dramatic decrease in solar PV cost, with panel prices falling down to about 0.66 USD Wp^{-1} (Energy Trend), clearly shows that this will be feasible in a near future. KeepIt is a hydraulic type energy storage technology that can be an important contribution to a foreseen future of a huge penetration of electricity from renewable sources.

In fact LACAES is completely modular by nature and well adapted to a huge number of applications, running from very small scale like pico solar systems to very large scale like pumped hydro.

5.1 Human scale: KeepIt Rural electrification

In what follows we will focus on very small scale applications for developing countries where electricity is a luxury reserved to the very few that can afford it and that live close to the grid. Electricity is very important in these societies, but it's simply not available. Even for those with access to the grid, 76 million are under-served in Africa alone (Stiftung Solarenergie Solar Energy Foundation).

During the night, 1.3 billion people won't have a switch to turn on the light, simply because they have no electricity (IEA, 2011). The vast majority (84%) of these off-grid users live in rural areas (Rahman u. Ahmad, 2013), either in Africa or in Asia. Although Africa has a smaller population, it has a higher number of users without electricity as in Asia, 598 and 593 millions, respectively (Stiftung Solarenergie Solar Energy Foundation). Moreover the number of off-grid users in Africa is expected to rise to 698 million, since population grows faster than the grid (Lighting Africa).

Having no electricity results in great disadvantages. Productive hours are restrained by sunlight's availability, and children that help their parents during the day won't be able to study at night. To cope with these disadvantages, off-grid users rely on solutions like kerosene for lighting, a petroleum derived fuel that pollutes and is potentially dangerous for human health, besides being a bad lighting option, as well as expensive (Practical Action). Nonetheless, the only reason for off-grid users opting for kerosene is that it is a relatively affordable solution. Kerosene can be bought in milliliters, just enough to have some hours of light. Users spend more in kerosene per year than

the value of most entry-level solar lamps that have a lifetime around 3 years (Lighting Africa). This product would help them save in lighting expenses but they cannot afford solar solutions because they cannot save enough from their extremely low income.

Moreover, mobile phones are an important tool for the improvement of users lives in developing rural areas where financial services are scarce (see GSMA (2012) and The Economist). Communication is an important service and this resulted in a rapid growth in the number of telecommunication users in developing countries were 500 million users have no access to electricity (Manchester u. Swan, 2013). This obviously rises the problem of how to charge mobile phones. Mobile phone users that have no access to electricity have to go to the closest charging station, spending significant amounts of time to reach them, and paying around 0.2 USD per charge (Manchester u. Swan, 2013).

5.1.1 Existing solutions

One of the most promising existing solutions are small solar powered lighting systems, commonly called pico-powered lighting systems (PLS). These products are rapidly gaining popularity and sales have been doubling each year in Africa, with 4 million units sold in 2012 (Lighting Africa). Most of the sold PLSs are priced from 20 to 50 USD with an average photovoltaic (PV) panel with a rated power of 3.5 W and a Li-ion or NiMH battery of 6 Wh. This product can provide 6-8 hours of light per day when fully charged, a representative share of this products also provides phone charging although this leaves little to no charge left in the PLS for lighting. PLS lifetime is limited by its battery, typically 3 years (Lighting Africa).

In Bangladesh solar home system (SHS) are a very popular solution with thousands of new installations per month (Rahman u. Ahmad, 2013). Solar home systems consist of a PV panel, battery and charge controller and, for larger SHS, an additional inverter needs to be installed in the SHS. Entry-level SHS are expensive compared to PLS, but provide much more energy, and are available from 10 up to 130 W PV panels and batteries of 180 to 1560 Wh, with prices from 105 to 600 USD (Grameen Shakti).

5.1.2 KeepIt™, a LACAES solution

LACAES is a mechanical system of storing energy. It is possible to charge the system using mechanical work from multiple possible sources, *e.g.* a solar panel, a wind mill, animal or human power. This means that LACAES not only can store energy, but can be a way of producing energy given using a manual hydraulic pump. KeepIt™ is a product that provides electricity to the off-grid user. Therefore, the user can produce and store energy using a product that is based on a very durable

and cheap technology (Fong, 2013). In its current state of development, KeepIt™ has a charge capacity of 10 Wh that can be recharged in 3 minutes by pumping liquid with an hydraulic foot-pump. An energy supply of 10Wh is enough to fully charge a phone((Manchester u. Swan, 2013)) or to have several hours of light, additionally, small power devices (lower then 15 W) can be powered like mini-fridges, fans, small TVs, radios, tablets and small laptops. KeepIt™ can be recharged as many times a day by simply pumping.

KeepIt™ is being developed with a 300 bar vessel, and the volume of 3.3 l is required to store 10 Wh. In the work presented here, a laboratory prototype has been built (more details in chapter 6), weighting 10 kg and occupying a volume of $30 \times 30 \times 50$ cm for a 7.6 l vessel (see Fig. 5.1).

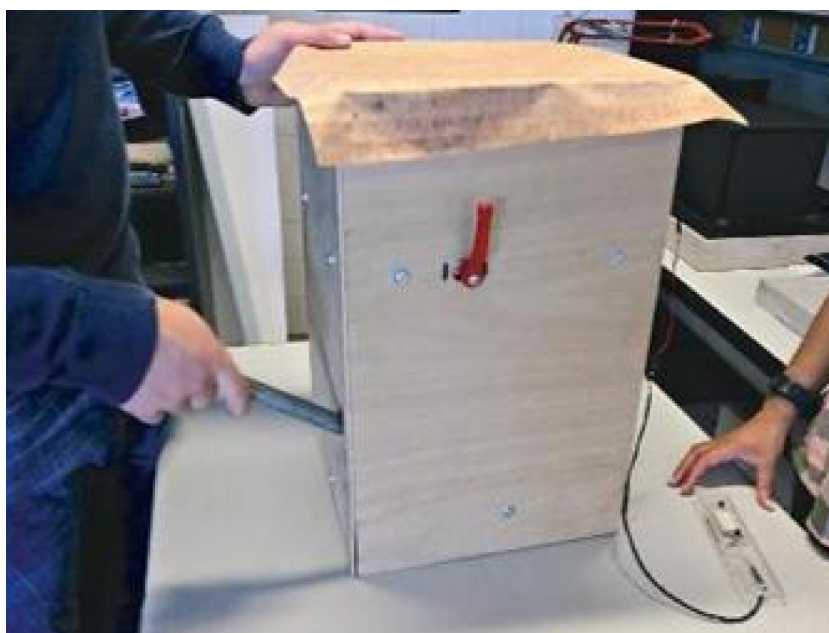

Figure 5.1: KeepIt™ early prototype. Adapted from (Séneca, 2014)

The next chapter is particularly dedicated to the description of the experimental setup that constitutes the prototype used for KeepIt™'s proof-of-concept.

6 KeepIt™Proof-of-Concept Prototype

Conteúdo confidencial (15 páginas)

7 Conclusions and future work

A new concept in energy storage was studied and tested. This new concept, LACAES – Liquid Assisted Compressed Air Energy Storage. In essence, LACAES is a compressed air energy storage type technology with an important difference that enables a much higher efficiency of operation. The transfer processes (both charging and discharging) are much slower in terms of the volume pumped per time unit and thus the gas pressure inside the high pressure chamber will suffer smaller changes. Accordingly, gas will tend to follow isothermal processes, minimizing losses associated with heat changes with the surroundings. In addition, since no gas is in principle released from the system in operation, heat exchangers that minimize energy losses in a complete cycle (charging plus discharging) are also easy to implement.

An important point that should be stressed about LACAES is the fact that the most critical building blocks of this technology (compressed gas bottles, Pelton turbines, etc.) are proven technologies, and in most cases are available on the market at affordable prices. This means that using this technology, in principle, it is possible to design solutions for different types of applications using components that already exist on the market. In fact, even for large scale applications, it is conceptually possible to consider modular systems that can be properly sized, for instance, using several interconnected bottles of pressurized nitrogen linked to one or more chambers containing the liquid fluid.

In what concerns energy density of this technology (per m^3 or per kg), preliminary studies indicate that if one uses the industrial standard value of 200 bar in the high pressure chamber, values of about 2 Wh l^{-1} and $1,3 \text{ Wh kg}^{-1}$ will be achieved. These values will of course depend on storage pressure, and are to be compared, for instance, with the considerably higher values of about 60 Wh l^{-1} and 24 Wh kg^{-1} for lead-acid batteries. This is not considered to be a significant drawback to this new technology since for almost all applications the most relevant parameter to consider is full cycle cost per recovered Wh.

A fully operational prototype for small scale applications, KeepIt™, was built and tested. Using this prototype a proof of concept for the technology was done, and the set of results obtained clearly shows that LACAES has a high potential as an energy storage technology. This prototype still needs a lot of further developments in order to achieve an industrial prototype exhibiting efficiencies higher than conventional CAES. This set of further developments was clearly identified and is in principle easy to implement in future work. Future work is foreseen to upgrade the prototype strongly in-

creasing the round trip efficiency. This includes the optimization of the following items:

1. Injector: a typical 14° tapered nozzle has a $c_v=0.98$ and a $c_c=0.98$ (Thake, 2000). This should result in an estimated nozzle efficiency of about 96%. This value is to be compared with the 38.4% efficiency measured on KeepIt™ prototype injector;
2. Generator: a DC-540 PMA generator, for instance, presents an efficiency of about 68% (Cobb, 2011). This value is to be compared with the 37.25% efficiency measured on KeepIt™ prototype generator;
3. Pelton turbine: typical Pelton turbines in pico-hydro applications have an efficiency up to 92% (Thake, 2000). This value is to be compared with the 53.31% efficiency measured on KeepIt™ prototype Pelton turbine;

These improvements are, in principle, quite straightforward to achieve, and are expected to lead to a second generation prototype with a round trip efficiency greater than 60%.

Bibliography

- [Buchmann 2003] BUCHMANN, Isidor: *BU-808: How to Prolong Lithium-based Batteries*. http://batteryuniversity.com/learn/article/how_to_prolong_lithium_based_batteries. Version:2003
- [Energy Trend] ENERGY TREND, 2014: *PV Spot Price*. <http://pv.energytrend.com/pricequotes.html>
- [Fong 2013] FONG, Danielle: *Making Economical Clean Energy at Planet Scale*. (2013). <http://www.lightsail.com/blog/making-economical-clean-energy-at-planet-scale/>
- [Grameen Shakti] GRAMEEN SHAKTI, 2014: *Price List of Solar Home System for Out of Grid Areas*. http://www.gshakti.org/index.php?option=com_content&view=article&id=115&Itemid=124
- [Grazzini u. Milazzo 2008] GRAZZINI, Giuseppe ; MILAZZO, Adriano: Thermodynamic analysis of CAES/TES systems for renewable energy plants. In: *Renewable Energy* (2008)
- [GSMA 2012] GSMA, 2012: *Mobile Money for the Unbanked: Annual Report 2012*. London, UK : GSMA, 2012
- [IEA 2011] IEA, 2011: *World Energy Outlook 2011: Energy for All : Financing Access for the Poor*. Paris Cedex, FRANCE : OECD/IEA, 2011, 2011
- [IEC 2011] IEC: *Electrical Energy Storage / International Electrotechnical Commission*. 2011. – Forschungsbericht
- [Jannelli u. a. 2014] JANNELLI, E. ; MINUTILLO, M. ; LAVADERA, A. L. ; FALCUCCI, G.: A small-scale CAES (compressed air energy storage) system for stand-alone renewable energy power plant for a radio base station: A sizing-design methodology. In: *Energy* (2014)
- [Lighting Africa] LIGHTING AFRICA, 2013: *Lighting Africa Market Trends Report 2012*. Nairobi, KENYA,
- [Lindley 2010] LINDLEY, David: THE ENERGY STORAGE PROBLEM. In: *Nature* (2010)
- [Lund u. Salgi 2007] LUND, Henrik ; SALGI, Georges: The role of compressed air energy storage (CAES) in future sustainable energy systems. In: *Energy Conversion and Management* (2007)

- [Manchester u. Swan 2013] MANCHESTER, Sebastian C. ; SWAN, Lukas G.: Off-grid mobile phone charging: An experimental study. In: *Energy for Sustainable Development* (2013)
- [Miller 2014] MILLER, Amanda H.: Energy storage is today where solar was in 2010-set for exponential growth. In: *Clean Energy* (2014). <http://www.cleanenergyauthority.com/solar-energy-news/energy-storage-is-today-where-solar-was-in-2010-112514>
- [Najjar u. Zaamout 1998] NAJJAR, Yousef S. H. ; ZAAMOUT, Mahmoud S.: PERFORMANCE ANALYSIS OF COMPRESSED AIR ENERGY STORAGE (CAES) PLANT FOR DRY REGIONS. In: *Energy Conversion and Management* (1998)
- [Practical Action] PRACTICAL ACTION, 2014: *Poor people's energy outlook 2014: Key messages on energy for poverty alleviation*. Rugby, UK,
- [Rahman u. Ahmad 2013] RAHMAN, Syed M. ; AHMAD, Mokbul M.: Solar Home System (SHS) in rural Bangladesh: Ornamentation or fact of development? In: *Energy Policy* (2013)
- [Stiftung Solarenergie Solar Energy Foundation] STIFTUNG SOLARENERGIE SOLAR ENERGY FOUNDATION, 2014: *Global Off-Grid Business Indicator - World*. OBIN World
- [Séneca 2014] SÉNECA, Hugo: Electricidade sem fios. In: *Exame Informática* (2014)
- [Thake 2000] THAKE, Jeremy: *The micro-hydro Pelton turbine manual*. Practical Action, 2000
- [The Economist] THE ECONOMIST, 2012: Solar lighting the way. <http://www.economist.com/node/21560983>