

901. A new time synchronous average method for variable speed operating condition gearbox

Xining Zhang¹, Guangrui Wen², Tingting Wu³

Department of Mechanical Engineering, Xi'an Jiaotong University, Xi'an, China

²Corresponding author

E-mail: ¹zhangxining@mail.xjtu.edu.cn, ²grwen@mail.xjtu.edu.cn, ³wtingting@mailst.xjtu.edu.cn

(Received 17 September 2012; accepted 4 December 2012)

Abstract. Gearbox is a widely used component for power transmission and speed change. Time synchronous average (TSA) is one of the most effective methods for vibration monitoring and diagnosis of gearboxes. Traditional TSA technique requires key-phase signal and constant operating speed. So the application of TSA is difficult in many situations such as in the case of gearboxes used in wind power generators and automobiles. A new method to implement TSA without key-phase signal for variable speed condition gearbox is proposed in the paper. The reported method is based on the estimation of instantaneous speed with time-frequency domain filtering and equal angular interval re-sampling of vibration signal. Experimental investigation performed in a variable speed gearbox test rig indicates that the proposed method can eliminate the influence of large speed fluctuation of gearboxes and provide satisfactory TSA results.

Keywords: time synchronous average, variable speed condition gearbox, time-frequency filtering, equal angular interval re-sampling.

1. Introduction

Being one of the most important parts of power transmission and speed changing, a gearbox is widely used in many industry fields. Due to its easiness to measure and analyze, vibration signals have been commonly employed in condition monitoring and diagnosis of gearboxes. The time synchronous average (TSA) technique is an effective vibration monitoring method for gearbox [1-3]. TSA can effectively attenuate the uncorrelated vibration components with the selected revolve frequency on spectrum. In the mean time, the TSA waveform intuitively reveals the condition of the monitoring gears on the selected shaft [4-7].

The key problem of TSA technique is to obtain the vibration samples against revolving angle. Commonly, there are two ways to achieve the above purpose. One is to employ the phase-lock technique with key-phase signal, while the other is to use a re-sampling method. The first method can track the speed fluctuation and directly collect the vibration samples against revolving angle. But it requires key-phase sensor and complex phase-lock circuit, which fails to achieve good tracking performance in large speed fluctuation. In many circumstances, it is difficult to install the key-phase sensor on the gearbox especially on the intermediate shaft. Gearboxes in wind power generator, machine tool, helicopter, mining excavator and automobile, is operating under large speed fluctuation condition [8-9]. The re-sampling method is based on instantaneous speed estimation and can process large speed fluctuation [10].

TSA based on instantaneous speed estimation has attracted great interest recently. F. Bonnardot gave an angular re-sampling method without tachometer, which is based on the estimation of meshing frequency or its harmonics by using a band-pass filter [11]. Sideband inside the filter band, which is produced by the slow speed fluctuation, is used to estimate the instantaneous speed. The method works well only under small speed fluctuation, which is less than the minimum speed of two meshing gears. On the basis of above work, F. Combet and L. Gelman extended automatic angular re-sampling algorithm for the estimation of the TSA signal of a particular shaft in a gearbox [12]. The innovation of the scheme is mainly concentrated on the automatic selection of the mesh harmonic, which is used for the shaft speed estimation. F. Combet and R. Zimroz proposed a method to estimate the instantaneous speed

relative fluctuation with short-time scale transform of vibration signal in 2009 [13]. The method still suffers from the limitation of small speed fluctuation.

In fact, the speed fluctuation of one shaft will result in the fluctuation of relative shaft rotation frequency and meshing frequencies. The instantaneous speed fluctuation can be well illustrated in joint time-frequency diagrams. The instantaneous speed can be extracted with time-frequency domain filtering. Based on the above thought, the paper gives a new time synchronous average method for variable speed gearbox without key-phase signal, and the method can be applied to the variable speed gearbox with large speed fluctuation. Variable speed gearbox test rig was built, and measurements were taken with accelerometers. The performance of the proposed method is verified by the processing of experimental data.

2. Estimation of instantaneous speed

Joint time-frequency analysis provides a tool for us to observe the signal both in time and frequency domain [14, 15]. Short Time Fourier Transform (STFT) is the most widely used method for non-stationary signal. So, it provides us a tool to view and track the instantaneous speed variations on the time-frequency diagram.

The basic principle of STFT is as follow: break up the signal into small time segments with filter, and then analyze each time segment with Fourier transform to get the spectrum. The totality of such spectrum indicates how the spectrum is varying in time. The transform formula of STFT and ISTFT are:

$$STFT_x(\tau, f) = \int_{-\infty}^{+\infty} x(t)h(t - \tau)e^{-j2\pi ft} dt \quad (1)$$

$$x(\tau) = \frac{1}{2\pi} \int_{-\infty}^{+\infty} \int_{-\infty}^{+\infty} STFT_x(t, \omega)h(\tau - t)e^{j\omega\tau} dt d\omega \quad (2)$$

where $h(t - \tau)$ is the moving window around τ , $STFT_x(\tau, f)$ is the time-frequency distribution.

Suppose we have a frequency modulated signal:

$$x = 10 \sin(2\pi \times 200t + 8 \sin(2\pi \times 10t)) + 10 \sin(2\pi \times 400t + 8 \sin(2\pi \times 10t)),$$

digitizing x with the equal time interval sampling we can get the corresponding digital signal $x_i, i = 1, 2, 3, \dots, N$. Fig. 1 provides the time-frequency diagram of signal x . The time-frequency diagram directly illustrates the frequency varying of a component against the time. The variations of the instantaneous frequencies of each component are clearly observed on the diagram.

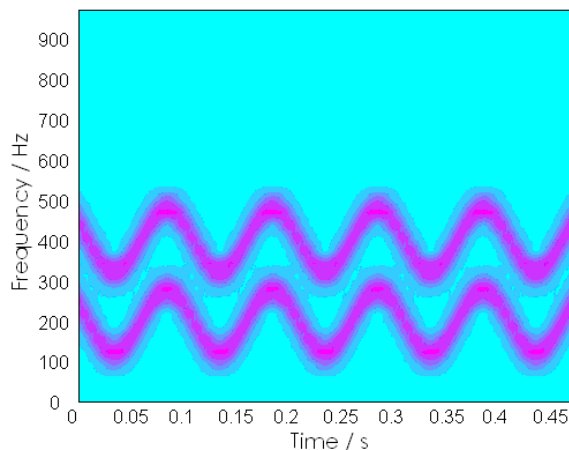

Fig. 1. Time-frequency diagram

In order to extract the varying instantaneous frequency component around 400 Hz, the coordinates of each maximum amplitude points of the above selected component is searched along the time axis. The model of instantaneous frequency against time is built with the coordinates. With the model we can obtain the value of instantaneous frequency at any moment of time axial.

3. Equal angular interval re-sampling of vibration signal

Time synchronous average requires angular based sampling time series. For an equal time interval sampling vibration signal at varying operating speed condition, it is essential to perform equal angular interval re-sampling [16]. In order to determine time moments of each re-sampling points, time-frequency domain filtering technique and Hilbert Transform are introduced.

A. Time frequency filtering

Suppose the model of the varying operating speed component is built with the above method. Band-pass filter curves in frequency domain are superimposed on the diagram at the point of maximum amplitude along the frequency axis of each moment on the time-frequency diagram. Fig. 2 indicates filter curve superimposed at point $P(k, f)$. Fig. 3(a) gives the filtered time-frequency diagram. With inverse short time Fourier transforms, the filtered signal (Fig. 3(b)) can be easily calculated. Obviously, the filtered signal is a mono-frequency signal at any moment.

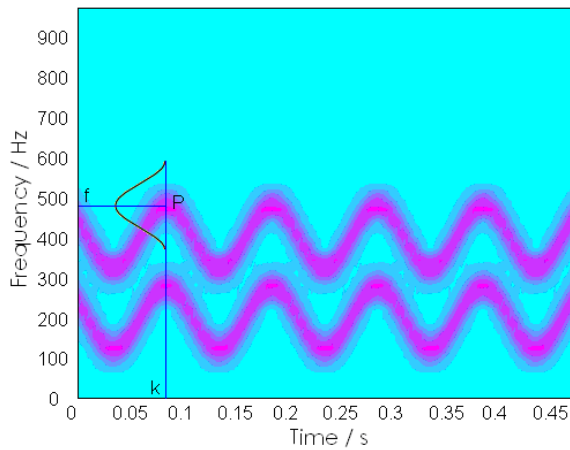

Fig. 2. Principle of time-frequency filtering

B. Phase information extraction with Hilbert transform

For a time series of $x(t)$, the definition of Hilbert transform is as follows:

$$y(t) = \frac{1}{\pi} \int_{-\infty}^{+\infty} \frac{x(\tau)}{t - \tau} d\tau \quad (3)$$

where $y(t)$ is the result of Hilbert transform. The analytic signal of signal $x(t)$ can be constructed as:

$$z(t) = x(t) + jy(t) = a(t)e^{j\Phi(t)} \quad (4)$$

where $a(t)$ is the amplitude function, $a(t) = \sqrt{x(t)^2 + y(t)^2}$, $\Phi(t)$ is the phase function,

$\Phi(t) = \arctan \frac{y(t)}{x(t)}$. Fig. 4 gives the unwrapped phase curve of the filtered signal.

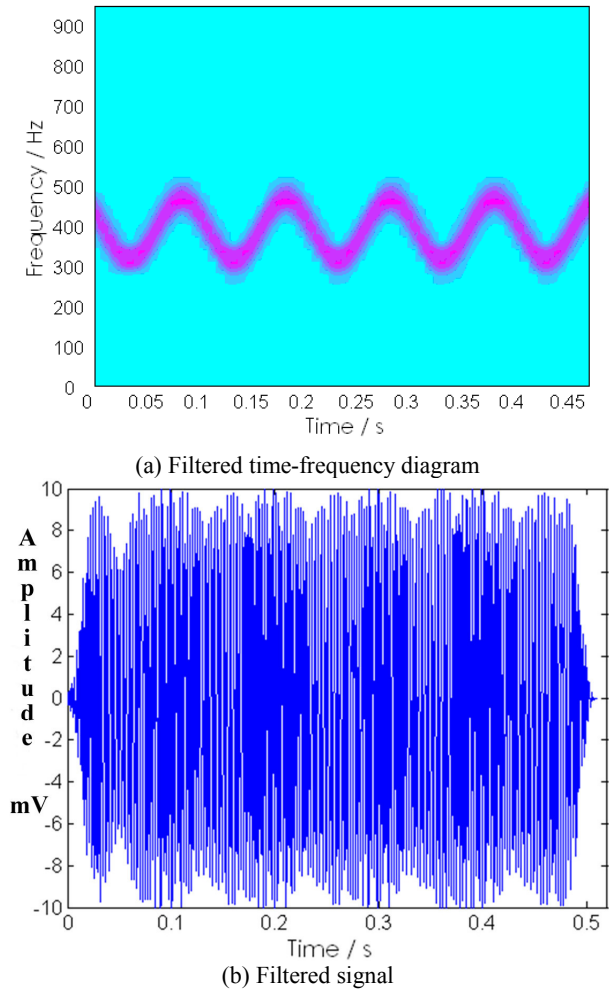

Fig. 3. Result of time-frequency filtering

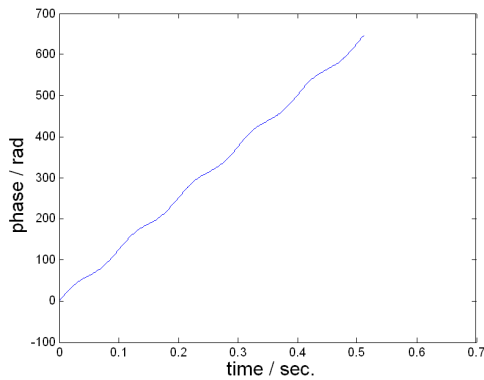

Fig. 4. Phase curve against time

C. Equal angular interval re-sampling

The aim of re-sampling is to transform the original equal time interval signal to equal angular interval signal. Suppose the original signal and re-sampling signal time moments are $x(t_i)$, $i = 0, 1, 2, \dots, N-1$ (ΔT is an original sampling interval) and $y(t_k)$, $k = 0, 1, 2, \dots, M-1$. The corresponding re-sampling time moments are t_k , $k = 0, 1, 2, \dots, M-1$. The relation between $y(t_k)$ and $x(t_i)$ can be described as:

$$y(t_k) = \sum_{i=0}^{N-1} x(t_i) \frac{\sin[(\pi / \Delta T)(t_k - i\Delta T)]}{(\pi / \Delta T)(t_k - i\Delta T)}, \quad k = 0, 1, 2, \dots, M \quad (5)$$

Practically, the above equation suffers from big computational volume, so it can be substituted with interpolation operation under the permission of computational precision.

By far, the key of equal angular interval based re-sampling is to determine the right re-sampling time moments t_k , $k = 0, 1, 2, \dots, M-1$. In fact, the re-sampling moments t_k can be easily obtained with the following steps (Fig. 5). Firstly, evenly divide the phase axial with appropriate angular interval Δa . For example Δa can be determined by $\Delta a = 2\pi / m$, where m indicates the number of points per circle in re-sample signal. Then the horizontal ordinates of each cross-point of parallel lines and the unwrapped phase curve are the re-sampling moments t_k .

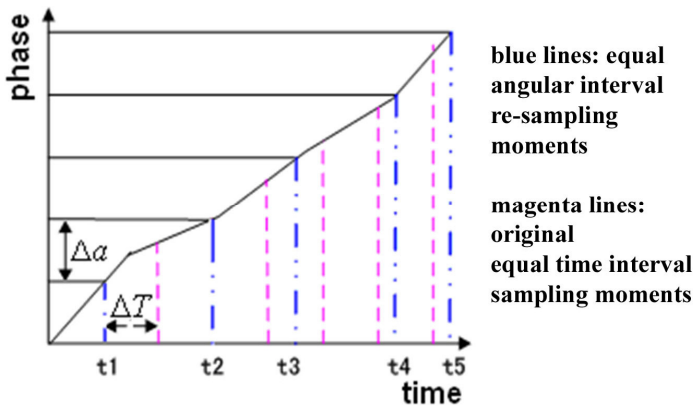

Fig. 5. Determination of the re-sampling interval

4. Implementation of time synchronous average

Based on the above work, equal angular interval based re-sampling signal is obtained. Suppose re-sampled signal $y(t_k) = f(t_k) + n(t_k)$, where $f(t_k)$, $n(t_k)$ are period signal and noise respectively, and it is truncated into P sections with m points in each section. Then the time synchronous average can be described as:

$$\bar{y}(t_k) = \frac{1}{P} \sum_{i=0}^{P-1} y(t_k) = \frac{1}{P} \sum_{i=0}^{P-1} f(t_k) + \frac{1}{P} \sum_{i=0}^{P-1} n(t_k) = f(t_k) + \frac{1}{\sqrt{P}} n(t_k), \quad k = 0, 1, 2, \dots, m. \quad (6)$$

Steps of implementation of time synchronous average for speed varying signal can be summarized below.

- 1) Vibration signal collecting with equal time interval mode.
- 2) Performing time-frequency analysis to obtain time-frequency diagram.
- 3) Instantaneous speed abstracting and modeling.
- 4) Performing time-frequency filtering and Hilbert transform to get phase curve.

- 5) Signal re-sampling with equal angular interval.
- 6) Performing time synchronous average.

5. Experiment and verification

In order to verify the performance of the proposed method, experiment is conducted on the gearbox test rig (Fig. 6 and Fig. 7). Key phase signal is collected from the input axis with photoelectric sensor. Vibration signals are collected from left and right bearing cases of gear box. The number of teeth of each gear in the experiment is illustrated in Fig. 6. Sampling frequency is set to be 12000 Hz in the experiment. The range of speed fluctuation of the input shaft is 800 rpm ~1500 rpm during the experiment.

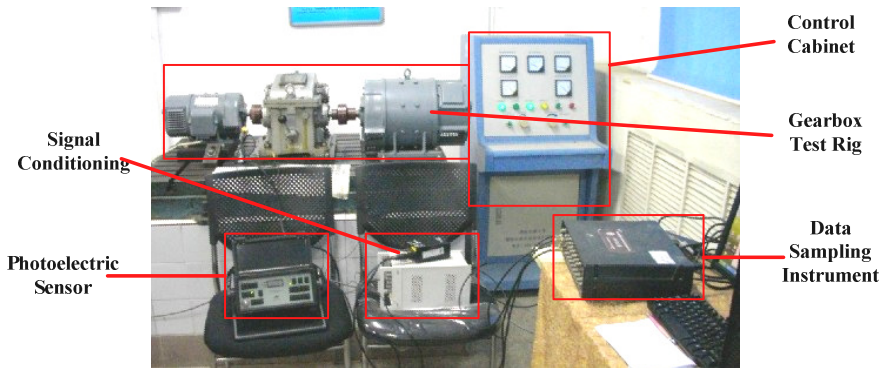

Fig. 6. Test rig for gearbox experiment

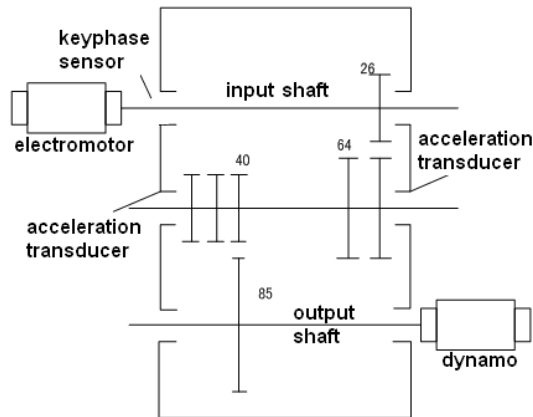

Fig. 7. Structure of gearbox test rig

Fig. 8 provides zoomed time-frequency diagram of the vibration signal. The curve of the instantaneous meshing frequency of gears in the input and intermediate shaft is clearly illustrated. The meshing frequency curve can be adopted to build the model and perform filtering, because there is a definite relation between meshing frequency and the input speed.

Fig. 9 presents the comparison of the spectrums between the original signal and the re-sampled signal. The average meshing frequencies of 495 Hz and 310 Hz, as well as modulation frequency of shaft rotation are clearly illustrated. Fig. 10 gives the waveform and spectrum of signal after time synchronous average. Waveform in Fig. 10(a) illustrates the vibration of gear

on input shaft during one round rotation, and variation of vibration amplitude in one round rotation is revealed. 26 vibration cycles which are corresponding to 26 gear teeth respectively can be easily determined. The same result can also be observed in Fig. 10(c) for the gear on the intermediate shaft.

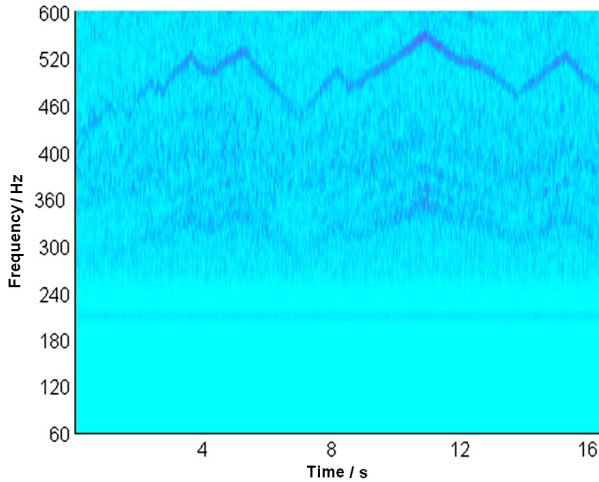

Fig. 8. Zoomed time-frequency diagram

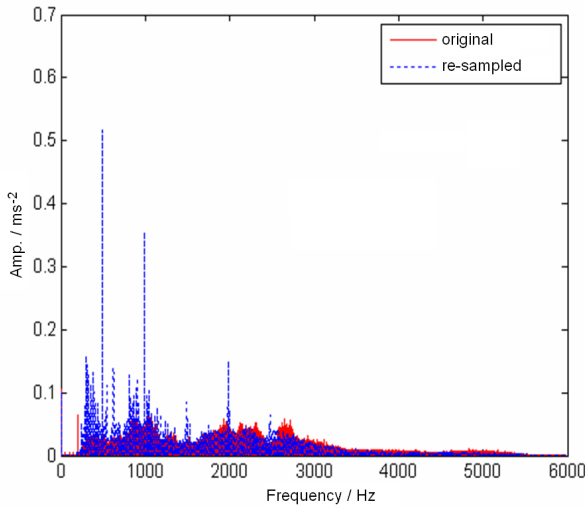

Fig. 9. Spectrums before and after filtering

6. Conclusion

A new method to implement TSA without key-phase signal for variable speed condition gearbox is proposed in the paper. The presented method is based on the estimation of instantaneous speed with time-frequency domain filtering and the equal angular interval re-sampling of vibration signal. From the above study, some main results can be summarized:

(1) The method of instantaneous frequency estimation with time-frequency analysis and time-frequency filtering is feasible and practical, especially in the case of wide range of speed fluctuation of input shaft.

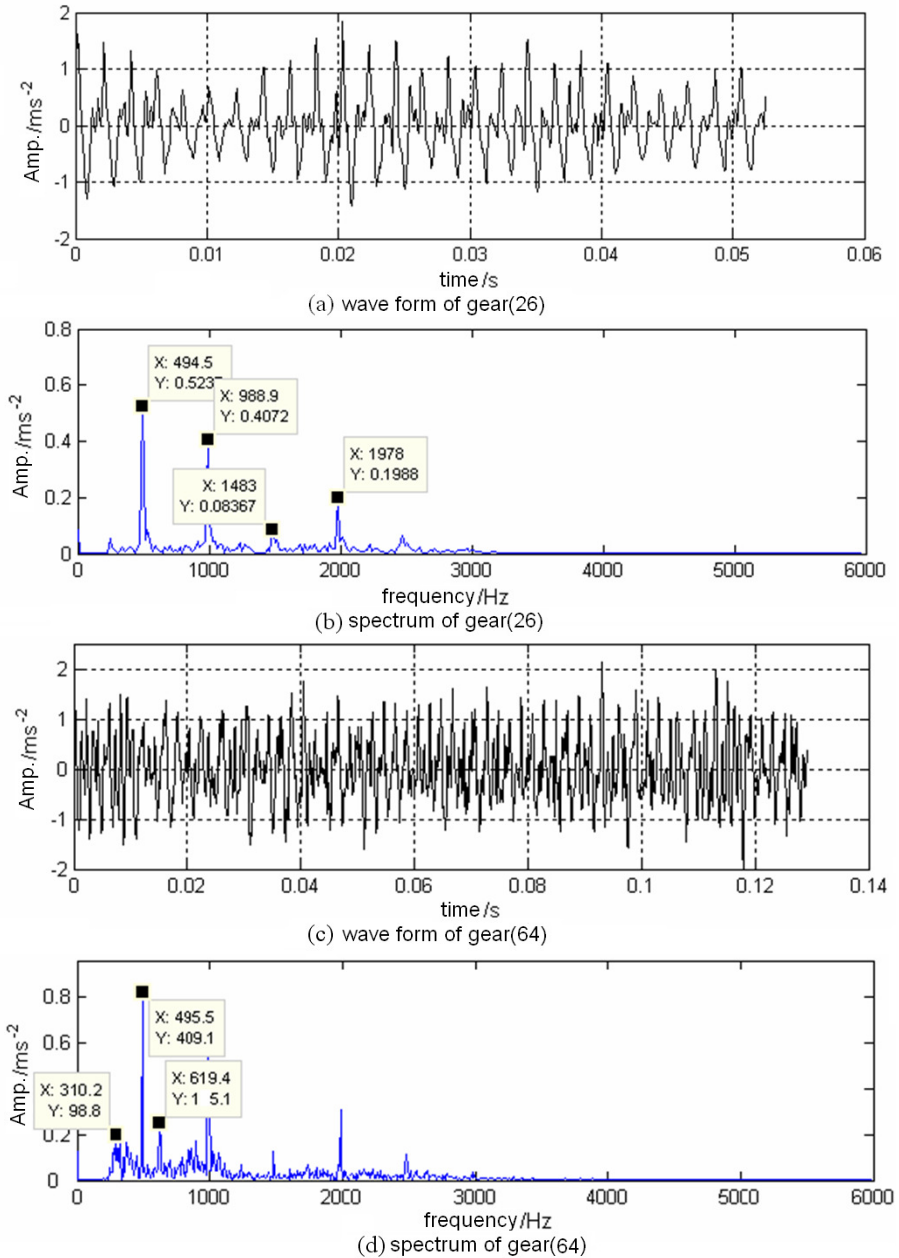

Fig. 10. Waveform and spectrum after time synchronous averaging:

- (a) signal waveforms on input shaft, (b) FFT spectrum of gears on input shaft,
- (c) signal waveforms on intermediate shaft, (d) FFT spectrum of gears on intermediate shaft

(2) Hilbert transform based equal angular interval re-sampling method can be employed to implement the re-sampling for vibration signal under varying speed condition. And in the mean time, equal angular interval re-sampling can eliminate the influence of speed variation to subsequent analysis and diagnosis.

(3) The proposed time synchronous average for vibration signal under variable speed operating condition is effective, and it demonstrates wide perspective and applicability in the

monitoring and diagnosis of wind power generators, automobiles and other applications using variable speed gear boxes.

Acknowledgements

This work was accomplished thanks to the Funds of National Natural Science Foundation of China (No. 51075323) and the National High Technology Research and Development Program of China (863 Program No. 2012AA040913).

References

- [1] **G. Dalpiaz, A. Rivola, R. Rubini** Gear fault monitoring: comparison of vibration analysis techniques. Proceedings of the Third International Conference on Acoustical and Vibratory Surveillance Methods and Diagnostic Techniques, Senlis, France, 2006, p. 623-637.
- [2] **S. Braun** The synchronous (time domain) average revisited. Review Article. Mechanical Systems and Signal Processing, Vol. 25, Issue 4, 2011, p. 1087-1102.
- [3] **Jian Song, Qing Wu, Changyong Pan, Zhixing Yang, Haitao Liu, Bingzhen Zhao, Xiao Li** Two-way digital video transmission over medium-voltage power-lines using time-domain synchronous orthogonal frequency division multiplexing technology. Tsinghua Science & Technology, Vol. 13, Issue 6, 2008, p. 784-789.
- [4] **T. Heyns, P. S. Heyns, J. P. De Villiers** Combining synchronous averaging with a Gaussian mixture model novelty detection scheme for vibration-based condition monitoring of a gearbox. Mechanical Systems and Signal Processing, Vol. 32, 2012, p. 200-215.
- [5] **Enayet B. Halim, M. A. A. Shoukat Choudhury, Sirish L. Shah, Ming J. Zuo** Time domain averaging across all scales: A novel method for detection of gearbox faults. Mechanical Systems and Signal Processing, Vol. 22, Issue 2, 2008, p. 261-278.
- [6] **M. M. Etefagh, M. H. Sadeghi, M. Rezaee, S. Chitsaz** Latent component-based gear tooth fault detection filter using advanced parametric modeling. Mechanical Systems and Signal Processing, Vol. 23, Issue 7, 2009, p. 2260-2286.
- [7] **Ming Yang, Viliam Makis** ARX model-based gearbox fault detection and localization under varying load conditions. Journal of Sound and Vibration, Vol. 329, Issue 24, 2010, p. 5209-5221.
- [8] **Zhipeng Feng, Ming Liang, Yi Zhang, Shumin Hou** Fault diagnosis for wind turbine planetary gearboxes via demodulation analysis based on ensemble empirical mode decomposition and energy separation. Renewable Energy, Vol. 47, 2012, p. 112-126.
- [9] **S. Braun** The extraction of periodic waveforms by time domain averaging, Acoustica, Vol. 32, 1975, p. 69-77.
- [10] **P. D. McFadden** A revised model for the extraction of periodic waveforms by time-domain averaging. Mechanical Systems and Signal Processing, Vol. 1, 1987, p. 83-95.
- [11] **F. Bonnardot, M. El Badaoui, R. B. Randall, J. Daniere, F. Guillet** Use of the acceleration signal of a gearbox in order to perform angular resampling (with limited speed fluctuation). Mechanical Systems and Signal Processing, Vol. 19, 2005, p. 766-785.
- [12] **F. Combet, L. Gelman** An automated methodology for performing time synchronous averaging of a gearbox signal without speed sensor. Mechanical Systems and Signal Processing, Vol. 21, 2007, p. 2590-2606.
- [13] **Francois Combet, Radoslaw Zimroz** A new method for the estimation of the instantaneous speed relative fluctuation in a vibration signal based on the short time scale transform. Mechanical Systems and Signal Processing, Vol. 23, 2009, p. 1382-1397.
- [14] **L. Cohen** Time-Frequency Analysis. Prentice Hall, Englewood Cliffs, NJ, 1995.
- [15] **M. Gröchenig** Foundations of Time-Frequency Analysis. Birkhäuser, Boston, 2001.
- [16] **Qiansheng Cheng** Mathematical Theory of Signal Digital Processing. Petroleum Industry Publishing House, Beijing, 1979.