

753. Research of dynamics of lifting equipment

B. Spruogis¹, A. Jakštas², V. Turla³, I. Iljin⁴, N. Šešok⁵

¹ Department of Transport Technological Equipment, Vilnius Gediminas Technical University

Plytinės 27, LT-10105 Vilnius, Lithuania

²Department of Machine Building, Vilnius Gediminas Technical University

Basanavičiaus 28, LT-03224 Vilnius, Lithuania

^{3, 4, 5}Department of Printing Machines, Vilnius Gediminas Technical University

Basanavičiaus 28, LT-03224 Vilnius, Lithuania

E-mail: ¹bsp@vgtu.lt, ²arunas.jakstas@vgtu.lt, ³vytautas.turla@vgtu.lt, ⁴pgilj@vgtu.lt, ⁵pgses@vgtu.lt

(Received 10 September 2011; accepted 14 February 2012)

Abstract. In the recent years, girder bridge cranes are replaced by double-beam overhead cranes with beams of rectangular cross-section. In addition, new materials are used for their fabrication, characterized by different values of allowable loads and deformations. In the paper, two overhead cranes from JSC "Vilniaus kranai" are considered. A mathematical model is proposed that enables assessment of the impact of the hydraulic damper built in the cargo suspension system upon the dynamic features of the crane in the beginning of the lifting process. It was determined that in such a way the period of vibration damping is reduced. However, the impact of the damper upon the dynamics of the metal structure of the crane is limited because of high mobility of the rope as compared to the mobility of the total structure.

Keywords: overhead crane, lifting process, hydraulic damper, stiffness of the rope, time diagram.

Introduction

Overhead cranes are important equipment of a majority of industrial and energy enterprises. Reliability of their operation predetermines a success of the manufacturing process. Simultaneously, the said equipment is important with respect to the occupational safety, so an assessment of dynamic load on its operation is an urgent technical problem. Depending on the dynamic properties of the crane, the parameters of the system for protection of the driver against vibrations and knocks are chosen [1].

In terms of dynamic computations, a crane is a united dynamic system that consists of the mechanisms, the supporting metal structure, the drive and the structural unit of the part of the building where the crane operates. An assessment of the variety of all interacting elements of the crane by dynamic computation is too complicated. However, it is not required in a majority of cases because not all factors contribute to formation of the dynamic loads to the same extent. On a transfer from the real machine to dynamic computation, the physical factors that are not important for the specific case of computation are not taken into consideration.

Maximum dynamic loads in the structure of a crane are induced in the beginning of the lifting process [2], which is attributed to the transients in mechanical systems because of rapid changes of resistance and driving forces. In the case of these processes, an assessment of the interaction between the mechanism and its electric engine is of a great importance [3].

While analyzing electromechanical systems, reliable solutions for formation of Simulink model are obtained in the environment of MATLAB [4, 5]. The dynamic curve of the crane load movement impacts the loads of its metal structure as well [6].

The load to the metal structure is transferred via the rope. On cargo lifting, the stiffness of the rope is growing, so the conditions of vibration damping in the rope and the time of transfer of the load from the cargo to the lifting mechanism alter [7]. Transfer of dynamic loads from the rope to the drum of the lifting mechanism is predetermined by the rope winding conditions [8].

Dynamic deformations and tensions in an overhead crane are calculated by applying the method of finite elements upon considering the crane as a three-dimensional system. In such a way, the loads simultaneously appearing on vertical and horizontal movement of the cargo are assessed [9]. It was found that when the cargo cradle moves along the overhead crane, the maximum deflection of its beam depends on the speed of movement of the cradle [10].

In the recent period, in course of improvement of automatic welding technologies, more and more widely overhead cranes with the metal structure consisting of two beams with "box-type" cross-section are used instead of girder ones used in the previous century. Because of this, the weight of the metal structure is reduced. In addition, the dynamic loads caused by the forces of inertia on changes of the speed of the crane movement are reduced as well. The mass of a girder crane is approximately equal to the mass of the lifted cargo, while the mass of a crane with "box-type" beams is equal to 0.1-0.3 of the lifted cargo (dependently on the span).

However, when the number of junctions in the structure is reduced, the forces that damp the vibrations excited in the beginning or the end of the lifting process become weaker. It is also important that the said vibrations are being damped upon operation of the engine of the lifting mechanism in the steady state mode. The increased duration of damping the elastic vibrations after a cessation of the impact of the excitation force or moment reduces the performance efficiency of the crane. Firstly, the vibrations of the crane structure cause vibrations of its cabin. Secondly, vibrations of the metal structure cause reduction of the fatigue resistance. So, the problem of vibration damping becomes of uppermost importance in cranes of the said type. The intensity of damping the vertical vibrations of a crane on its operation may be increased by hydraulic damper built in the structure or the lifting mechanism. The second version is more simply to accomplish.

The structure and dynamic model

This paper considers the possibility to apply vibration damping in overhead cranes produced by JSC "Vilniaus kranai" by means of a hydraulic damper built in the cargo suspension system. The attention was focused to the processes that take place in the beginning of the lifting process because it distinguishes itself for the hardest operating conditions of the drive of the lifting mechanism and the metal construction.

The cranes of two types were examined: TAII-12,5-10, 8-6 (the crane 1) and TAII-10-20, 7-10 (the crane 2), with the lifting capacity of 12.5 tons and 10 tons, respectively. For production of these cranes, steel S355J63 or S355NL (dependently on the ambient temperature) is used. This steel, used instead of the ordinary structural steel, leads to the reduction of the weight of the metal structure. However, the impact of the forces of inertia of the cargo increases.

The metal structure of the crane consists of two beams of rectangular cross-section welded of plates of the above-mentioned steel. The masses of the beams are 1240 kg and 3420 kg, respectively. The scheme of the crane is provided in Fig. 1. The span B of the first crane equals 10.8 m and the span of the second crane - 20.7 m. The lifting mechanism is installed in the trolley. In the mechanism, an asynchronous engine with a rope drum connected via a planetary reducer is used. The ratio of the reducer equals to 185.3 for both cranes. The repeatability of the system of pulleys equals to 6 in the first crane and to 4 in the second crane. Their operational lifting speeds are equal to 3.2 and 5.0 m/minute, respectively.

In Fig. 2, the scheme of the lifting mechanism with a built-in hydraulic damper is presented. The counterweighing pulley 1 is fixed to the lever 3 and is supported against the frame of the trolley via two suppressive springs 2 . The other end of the lever is connected to the handle of the piston of the hydraulic damper. For increasing the impact of the hydraulic damper upon the dynamics of the crane, the stiffness of the suppressive springs was chosen equal to the initial stiffness of the rope upon the maximum length of the rope.

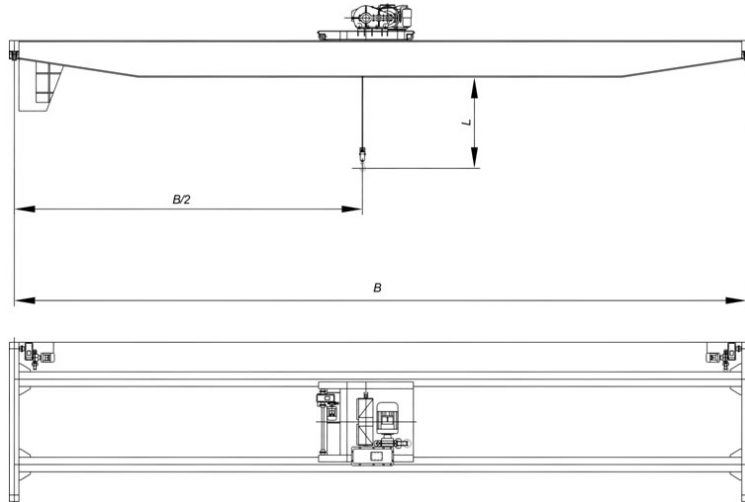

Fig. 1. The scheme of an overhead crane

On the basis of the dynamic model of the overhead crane (Fig. 3), the expressions of potential and kinetic energy as well as the dissipation function are developed:

$$\begin{aligned} \Pi &= \frac{1}{2} \left(\frac{k \cdot k_d}{k + k_d} (x_1 - R\varphi + x_0)^2 + k_0 x_0^2 \right), \\ T &= \frac{1}{2} (m_0 \dot{x}_0^2 + m_2 \dot{x}_1^2 + I \dot{\varphi}^2), \\ \Phi &= \frac{1}{2} \left((h + h_d) (\dot{x}_0 - R\dot{\varphi} + \dot{x}_1)^2 + h_0 \dot{x}_0^2 \right), \end{aligned} \quad (1)$$

where x_0 – deflection of the metal structure, x_1 – coordinate of the lifting mechanism, φ – rotation angle of the drum of the lifting mechanism multiplied by the repeatability of the rope of the lifting mechanism, m_0 – mass of the metal structure, m_2 – mass of the lifted cargo, I – moment of inertia of rotating parts of the lifting mechanism, R – radius of the drum of the lifting mechanism, k_0 – stiffness of the metal structure of the crane in the vertical direction, k – stiffness of the rope, h_0 – damping coefficient for the metal structure, h – damping coefficient for the rope, k_d – stiffness of the supplemental springs, h_d – damping coefficient of the damper.

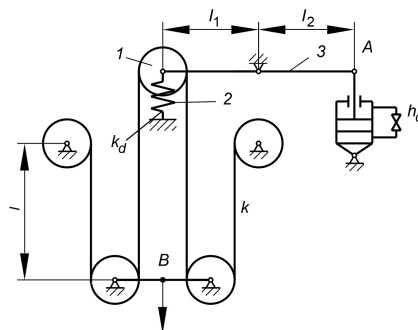

Fig. 2. The scheme of installing a hydraulic damper in the cargo suspension system

The mass of the first crane is 4080 kg and the mass of the second crane is 8700 kg. In course of the computation, it was found that $I = 1.5 \cdot 10^3 \text{ kg} \cdot \text{m}^2$ for both cranes. The damping coefficient $h = 0.225 \cdot 10^3 \text{ kg/s}$ for both cranes. For the first crane, $h_0 = 17.56 \cdot 10^3 \text{ kg/s}$, and for the second crane - $13.98 \cdot 10^3 \text{ kg/s}$.

The stiffness of the metal structure of the crane was found on the basis of the value of the static deflection on lifting the maximum cargo. In the case of the first crane, this deflection equals 17 mm, and in the case of the second crane - 31 mm. So, k_0 for the first crane is equal to $7.35 \cdot 10^6 \text{ N/m}$ and for the second crane - $3.22 \cdot 10^6 \text{ N/m}$.

The values of the stiffness of the rope were accepted in accordance with [11], i.e. the stiffness gradually increases upon higher rope deformation. The initial values of the stiffness for the first crane are $0.58 \cdot 10^6 \text{ N/m}$ (when the length of the rope equals 6 m) and $1.16 \cdot 10^6 \text{ N/m}$ (when the length of the rope equals 3 m). For the second crane, the initial values of the stiffness are $0.28 \cdot 10^6 \text{ N/m}$ (when the length of the rope equals 10 m) and $0.56 \cdot 10^6 \text{ N/m}$ (when the length of the rope equals 5 m).

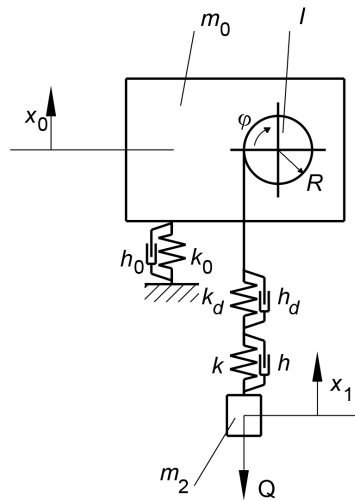

Fig. 3. Dynamic model of an overhead crane with a hydraulic damper installed in the cargo suspension system

The value of the damping coefficient in the hydraulic damper $h_D = 0.4 \cdot 10^6 \text{ kg/s}$ was accepted according to [12] and used in investigation on the dynamics of the first and the second cranes.

When the expressions of potential and kinetic energy as well as the dissipation function (1) are inserted in Lagrange equations of the second type, a system of three equations is obtained. Such a system of equations is expressed in operator notation, thus obtaining solutions for formation of Simulink model in MATLAB. It is assumed that the rotational speed of the engine is constant and it is computed on the basis of the given lifting speed upon assessment of the repeatability of the system of pulleys.

The results of the investigation enable assessment of the possibility of damping crane vibrations by means of a hydraulic damper.

The results of the investigations

During research it was determined that during start of the engine of the lifting mechanism, considerable dynamic loads affecting the mechanism are generated (Fig. 4). Independently on

the length of the rope, the vibrations appearing in this zone are essentially harmonic for both cranes and their frequency is 11–12 Hz. Within the first period, the dynamic factor:

$$K_d = \frac{F_{max}}{F_s}, \quad (2)$$

where F_{max} – maximum affecting force, F_s – gravity force of the lifted cargo. The value of the factor is 1.7. Such vibrations disappear within 1.8 – 2 seconds.

Thanks to the hydraulic damper, these vibrations are eliminated. The dynamic loads express themselves in the first period only (Fig. 4).

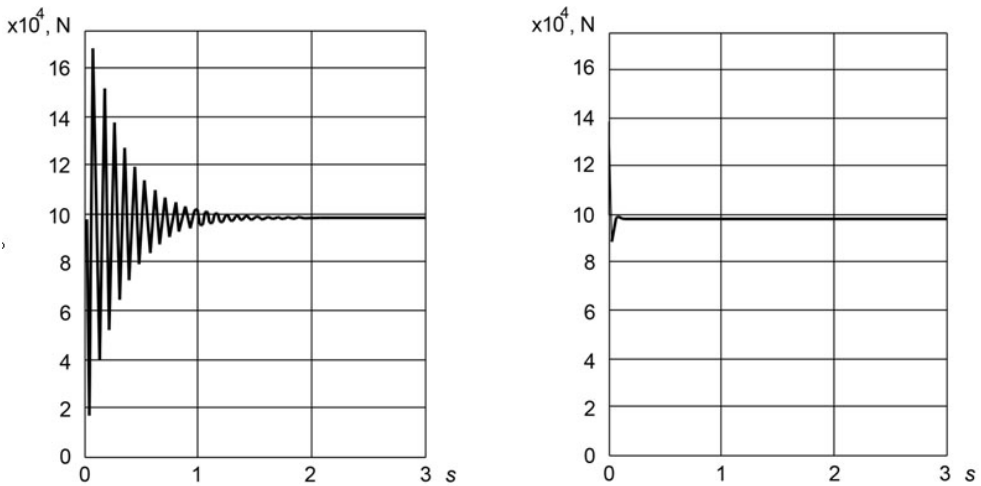

Fig. 4. The time diagram of the force that impacts the lifting mechanism (the crane 2, rope length $L= 6$ m): a – without damper, b – with damper

For this cause, in the beginning of the lifting process, the aforementioned 12 Hz vibrations are transferred to the suspension (Fig. 5, a) upon the impact of the force of inertia of the cargo and the force of stiffness of the rope. However, such vibrations disappear within several periods, i.e. within 3 – 5 seconds. Simultaneously, vibrations of considerably lower frequency (2.0 – 2.2 Hz) appear. These vibrations decay within 12 – 16 seconds from the beginning of the lifting process. An exception is provided by the case of the second crane when the length of the rope is not big – equal to 3 m. In such a case (Fig. 5, b), the vibrations within first 6 seconds are sharply biharmonic – they consist of 11 Hz and 2.0 Hz harmonics.

Here, vibrations of a higher frequency last for one period only. However, the dynamic factor may increase, in particular, if the rope is shorter, when K_d is up to 2 (Fig. 5a, b). The period of damping the vibrations of the lower frequency (2 Hz) falls down to 4 – 6 s, i.e. 2 – 2.5 times, as compared to the system without a damper (Fig. 6).

In the course of calculation of the system without a damper it was determined that in the beginning of the lifting process, vibrations of the lower frequency are induced in the crane metal structure as well. In the first period, value of the dynamic factor is up to 1.15. This gradually falling load acts for 14 – 16 seconds. In addition, inconsiderable variable load (11 – 12 Hz) manifests in the first period. In case of a system with a damper, such vibrations are not excited, and damping of vibrations of the lower frequency is remarkably intensive. Within the first period, the dynamic load of the metal construction is reduced by 15-20% and is totally eliminated within 6-7 s.

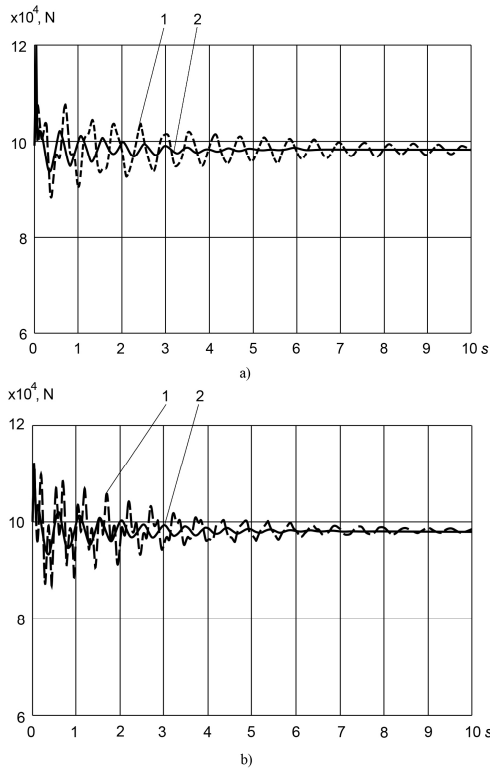

Fig. 5. The time diagram of the force that affects the end of the rope, the crane 2:
a) $L = 6$ m, b) $L = 3$ m: 1 – without damper, 2 – with damper

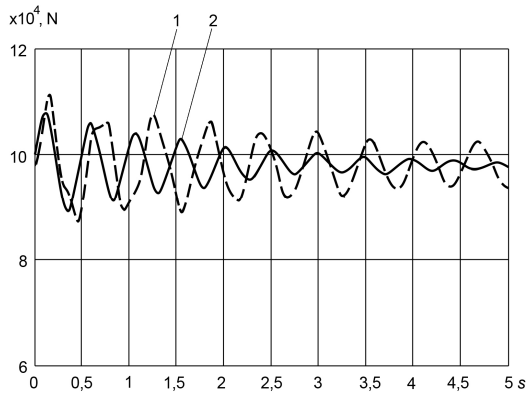

Fig. 6. The time diagram of the load of the metal structure of the crane (the crane 2, $L = 6$ m):
1 – without damper, 2 – with damper

Conclusions

1. In the case of application of hydraulic damper built in the cargo lifting mechanism of an overhead crane, its drive is protected against dynamic loads within the frequency of 11– 12 Hz.
2. Owing to the hydraulic damper, the vibrations of the said frequency excited in the rope at the lifting mechanism are eliminated and the period of damping of vibrations of the lower frequency (2.0 – 2.2 Hz) is reduced by 2 – 2.5 times.

3. Upon using a hydraulic damper, the period of damping the vibrations (with the frequency 2.0 – 2.2 Hz) that are excited in the metal structure of an overhead crane in the beginning of the lifting process is reduced from 15 – 16 s to 5 – 6 s.
4. The impact of a hydraulic damper built in the lifting mechanism upon the crane metal structure is limited by mobility of the rope.

References

- [1] **Piette A., Malchaire J.** Technical characteristics of overhead cranes influencing the vibration exposure of the operators. *Applied Ergonomics*, Vol. 23, 1992, p. 121 – 127.
- [2] **Bogdevičius M., Vika A.** Investigation of the dynamics of an overhead crane lifting process in a vertical plane. *Transport*, Vol. 20, Issue 5, 2005, p. 176 – 180.
- [3] **Augustaitis V., Gičan V., Iljin I., Šešok N., Geleževičius V.** Model of a multi-sectional web offset printing press drivesection, controlled by electronic shaft. *Solid State Phenomena*, Vol. 113, 2006, p. 103 – 108.
- [4] **Gičan V., Slivinskas K., Augustaitis V.** Research of force drives of the production gear hobbing machine with CNC 2008. *Mechanika*, Vol. 2, Issue 70, 2010, p. 43 – 47.
- [5] **Slivinskas K., Gichan V., Striška V., Poška A. J.** Optimization of transport movement parameters of the transfer manipulator for the quenching bath according to the technological process requirements. *Solid State Phenomena*, Vol. 164, 2010, p. 411 – 418.
- [6] **Ju F., Choo Y. S., Cui F. S.** Dynamic responses of tower crane induced by the pendulum motion of the payload. *International Journal of Solids and Structures*, Vol. 43, Issue 2, 2006, p. 366 – 369.
- [7] **Kaczmarczyk S., Ostachowicz P.** Transient vibration phenomena in deep mine hoisting cables. Part 1: Mathematical model. *Journal of Sound and Vibration*, Vol. 262, 2003, p. 219 – 244.
- [8] **Etsujiro Imanishi, Takao Nanjo, Takahiro Kobayashi** Dynamic simulation of wire rope with contact. *Journal of Mechanical Science and Technology*, Vol. 23, 2009, p. 1083 – 1088.
- [9] **Wu J. J.** Dynamic response of a three-dimensional framework due to a moving carriage hoisting a swinging object. *International Journal for Numerical Methods in Engineering*, Vol. 59, 2004, p. 1679 – 1702.
- [10] **Ogumanam D. C. D., Hansen J. S.** Dynamic response of an overhead crane system. *Journal of Sound and Vibration*, Vol. 213, 1998, p. 889 – 906.
- [11] **Spruogis B., Jakštas A., Turla V., Iljin I., Šešok N.** Dynamic reaction forces of an overhead crane on lifting. *Transport*, Vol. 26, Issue 3, 2011, p. 279 – 283.
- [12] **Titurus B., Du Bois J., Lieven N., Hansford R.** A method for the identification of hydraulic damper characteristics from steady velocity inputs. *Mechanical Systems and Signal Processing*, Vol. 24, 2010, p. 2868 – 2887.