

## 710. Movement control of active/passive exercisers

Beniamin Chetran<sup>1</sup>, Eموke Szelitzky<sup>2</sup>, Alexandra-Maria Aluței<sup>3</sup>, Dan Mândru<sup>4</sup>

Technical University of Cluj-Napoca, Romania

E-mail: {<sup>1</sup>Beniamin.Chetran, <sup>2</sup>Eموke.Szelitzky, <sup>3</sup>Alexandra.Alutei, <sup>4</sup>Dan.Mandru}@mmfm.utcluj.ro

(Received 10 September 2011; accepted 14 February 2012)

**Abstract.** The anatomical structure and biomechanics of the upper limb are presented in the first part of the paper. Several diseases and injuries specific to upper limb that conduct to a rehabilitation treatment are emphasized. The physical therapy promotes motion as a basic element of rehabilitation. This kind of rehabilitation therapies are based on movement and/or forces exercises usually performed under the supervision of a professional, frequently using various exercisers.

Two different rehabilitation systems are described. The first one is an electrical actuated, wearable wrist exerciser. Its role is regaining the wrist joint's functions, enhance strength of muscles and stability, and improve the firmness and flexibility of the muscles and ligaments in safe operation during the performed exercises. The second one permits a large variety of active or passive exercises, aiming the rehabilitation of the shoulder, elbow and wrists articulations as well as regaining the movement capacity and patient's motor skills. It includes a stationary one degree of freedom mechanism, pneumatically actuated. Aspects concerning the design, modelling, simulation and interfacing of both systems are given.

**Keywords:** exerciser, physical therapy, wrist, upper limb.

### Introduction

The human upper limb is a complex biological subsystem, consisting of 32 bones mobilized by 43 muscles involving 35 joints. It consists of three main segments (arm, forearm and hand) connected together and with the trunk through the following important joints: shoulder joint – a spherical joint which has three degrees of freedom: elbow joint - which is one degree of freedom joint, wrist joint - a joint which has two degrees of freedom [1]. The biomechanics of the upper limb have been examined extensively to understand neural control of movement as well as the interaction of osseous and tendons anatomy, muscles structure, mobility of joints, to improve its function [2, 3]. The upper limb is an extremely mobile organ that is capable of a large variety of gestures, based on the anatomical movements presented in Fig. 1 together with their average movement amplitudes. Multiple finger movements to achieve the grasping function complete the upper limb biomechanics.

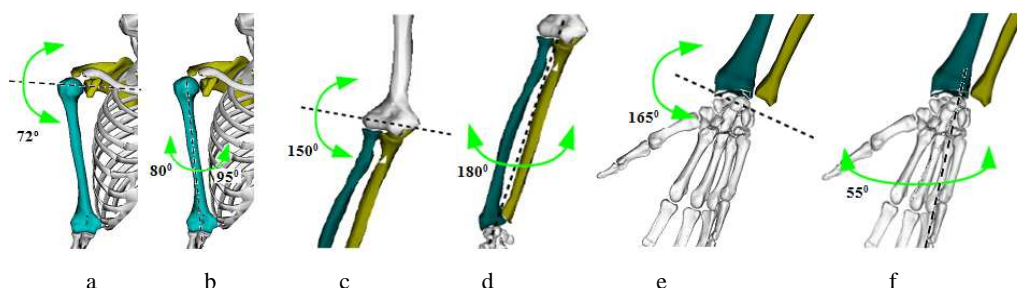

**Fig. 1.** The anatomical movements of the upper limb: a) abduction-adduction of the arm; b) internal-external rotation of the arm; c) flexion-extension of the forearm; d) pronation-supination of the forearm; e) flexion-extension of the hand; f) abduction-adduction of the hand

There are a variety of diseases that lead to partial or permanent loss of the upper limb functions, with a significant impact on overall health status: neurological diseases (e.g. nervous system defects, stroke, lack of sensibility) or structural matter diseases (e.g. absence of segments, fractures, vascular lesions, burns, and osteoporosis). Therefore, rehabilitation procedures depend on the type of injury, location, complexity and the purpose of the rehabilitation program.

The physical therapy is considered a field of conventional medicine, which involves evaluation, diagnosis and recovery from a range of diseases, disorders, and disabilities, by a whole re-educational process. The term recovery, embraces all the processes of education, adaptation, and rehabilitation which permits the reconstruction, total or partial, of the normal capacity, or by generating new ones, so as to allow the integration of a person in active social life. The World Congress of Physical Therapy (WCPT 1999) recognizes that “physiotherapy is concerned with identifying and maximizing movement potential within the spheres of promotion, prevention, treatment and rehabilitation” [4]. The physiotherapeutic exercises can be divided in passive exercises, in this case the movements are made with the aide of a therapist or a system, and active ones when the patient can action his muscular system to carry out the physiotherapeutic exercises [5].

The duration and number of the physical therapy training sessions can be increased by using different exercisers, compared with manually assisted procedures which are limited by the fatigue of the therapist. The exercisers allow setting multiple functional parameters and quantifying the patients’ progress, which leads to a more efficient rehabilitation process. According to the movement type, the exercisers can be classified according to type of movement in passive, active or active with resistance systems, with different degrees of freedom. Several systems used for upper limb rehabilitation were studied. The ARM Guide [6] is a system designed to achieve passive movements of the entire upper limb. With its three degrees of freedom allows anterior and posterior movements of the arm and shoulder, flexion - extension of the forearm. A system for the wrist recovery through flexion - extension exercises by passive and active assisted movements is presented in [7]. Sensors are used for strength and displacement measurements. A prototype of a robotic system based on a pentalater mechanism with two degrees of freedom, is described in [8]. The proposed device is designed to be used in passive and active upper limb’s mobilization. A rehabilitation support system is developed for various resistance trainings of upper limb motor function [9]. This system supports the occupational therapy for recovering physical functions, being equipped with the teaching/guided function for personalized rehabilitation. The teaching/ guided function enables the therapists to easily make not only training trajectories but also training programs to suit the individual needs of the patients. Another interactive device is the arm trainer presented in [10]. The patient has the elbow joints flexed at about 90°. Each hand grasps a handle and can be moved in one direction. Two handle sets are available, one with horizontal axis for the forearm pronation - supination and one with vertical axis for the wrist flexion - extension. The device position has to be changed depending on the selected movement. A display shows the number of cycles performed. Force and position sensors are used to enable different control modes, including position and impedance control strategies.

## **The Wrist Trainer**

The aim of the bellow-described exerciser is to be cost effective, efficient, easy to use, lightweight, containing simple mechanisms and components made of adequate materials. It represents an improved variant of a previous system [11]. Its role is regaining the wrist joint’s functions, enhance strength of muscles and stability, and improve the firmness and flexibility of the muscles and ligaments in safe operation during the performed exercises.

The most important constraints and imposed design data are: patient safety; maximum abduction - adduction angle:  $\pm 30^\circ$ ; maximum flexion - extension angle:  $\pm 60^\circ$ ; maximum angular speed: 0.15 rad/sec; the mechanism axes has to overlap the natural axes; must be provided the opportunity to measure and collect the angular speed, the angle and the forces; the exerciser must be reconfigurable and adjustable in order to be used by the both hands and by different patients.

The geometrical characteristics are based on anthropometric data regarding the hand and forearm as well as on the wrist biomechanics. The hardware component of the exerciser is based on a serial two degrees of freedom mechanism, whose structural scheme is given in Fig. 2. We note: 1 – element which is connected to the forearm, 2 – intermediary link, 3 – element connected to the hand, A, B – drive joints for flexion - extension, respectively, for abduction - adduction.

The mechanism' elements are made of aluminium alloy reducing the total weight of the system at 500 g. There are four adjusting possibilities: one on the forearm for the flexion - extension, one for the height, one for the abduction – adduction axis, and one for the length of the hand. It is actuated by two 24 VAC synchronous motors through geared transmission with following characteristics: rated frequency 50 Hz, input power  $<4.5$  W, output power 1W, noise  $<40$  db, output torque 7 kgf-cm at 6 rpm, 27 kgf-cm at 1.6 rpm. In order to limit the amplitude of movement in accordance with the wrist biomechanics, four software limits were programmed based on angle measurements by two encoders. The forces are read by four pressure sensors mounted in such manner to be able to measure the forces exhibited by the both movements. Fig. 3 shows the 3D model of the exerciser and different positions of the hand support.

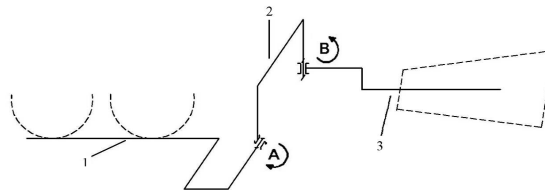

Fig. 2. The structural scheme of the Wrist Trainer

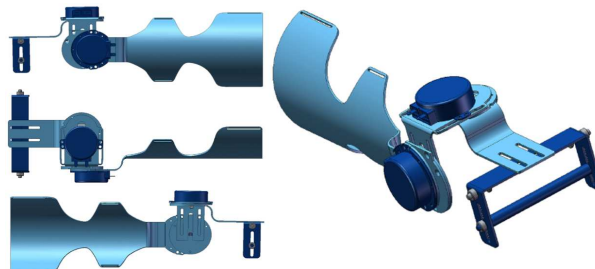

Fig. 3. The 3D model of the Wrist Trainer

The control of the device is made by two boards: the logic board and the driving board. The logic board (Fig. 4a) is using an ATmega8535 controller, eight optotransistors that drives the power board, two incremental encoders for reading the angles of the mechanism, four pressure sensors, four switch buttons for menu navigation, a LCD for displaying menu, one MAX 232 used for serial communication with the PC, angular potentiometer for varying the motors speed. The menu of the controller is as simple as possible; it can be scrolled by pressing “OK”, “ESC”, “UP”, “DOWN” buttons and after the patient reach the desired exercise, a confirmation is waited by pressing the “OK” button. For safety reasons, the “ESC” button is activating an interruption pin that immediately stops the motors. This button doesn't reset the controller,

because of data loss prevention, it only resets some of the variables used by program to call subroutines and the output ports for the motor drive. The angle measurement function that read two rotary encoders is active as long as the logic board is supplied. The ATmega8535 reads these incremental encoders and the movement direction is decided using A and B signals. In order to meet the data collection requirement the controller has implemented a communication function that is used for sending the measured data and also for service purposes.

The driving board (Fig. 4b) is made from two MOS FET H bridges and the required circuitry for a proper operation. In case of necessity the driving board is already prepared to use 220 AC synchronous motors with the specification above. Figure 4b show only a half of the driving board.

The PC interface of the equipment comprises two parts. First part is a frame (Fig. 5a) that allows viewing, creating, modifying and deleting a patient data. The patient data are the identification data, diagnostic, proposed exercises and the data collected during the exercises. With the aid of the second part (Fig. 5b) of the PC interface it's possible to control the equipment in the same manner as from the logic board. To do that the PC is sending to the microcontroller string commands like 'exnr; m1&m2; integer', where "exnr" is the exercise type function "m1&m2" is the motor/s used and "integer" is an integer value representing the speed of the motor/s. The same frame it's used to real time read the angles, speed and forces values that are send by the controller.

### **The Linear Upper Limb Exerciser**

The second rehabilitation system is dedicated to both active and passive exercises. It represents a development and improvement of a previous project of the authors [12]. User, in the sitting or standing position, has its upper limb "linked" with a mechanical structure (the hand is in contact with a handle). Thus the upper limb is mobilized, actively or passively, in front or side work positions (Fig. 6).

The mechanical structure of the system is made by joining two pneumatic cylinders. The rod ends of the cylinders are fixed and for stabilizing this configuration an additional sliding joint was added. The handle was mounted on the top of the mechanism. The block diagram of the system is given in Fig. 7.

The control system is made from a PC (1) that communicates with a NI USB 6009 console (2) via USB. The IT202 pressure regulator is controlled by the analogue output of (2) through an amplifier (3). The valves are activated digitally with the aid of the amplifier (5). The push and pull forces are measured by two force sensors (4) and for measuring the travelled distance an encoder (6) was added. The pressure is read by the built in pressure sensor of the IT202.

The pneumatic components (Fig. 8) are: two C85E25-160 pneumatic cylinders, one EVZ512 3/2 solenoid valve, one IT202-F003B, electrically adjustable pressure regulator, one EVZ5320 5/3 solenoid valve and one manual pressure regulator.

When the "Main" solenoid valve is open the compressed air set at 4 bar flows into the IT202 and PR2 pressure regulators. The PR2 is set at 2 bar and is connected at the 3 and 5 terminals of the 5/3 valve and the output of the IT202 is connected at the terminal 1 of the 5/3 valve. The terminals 2 and 4 are connected at the cylinders terminals. By adjusting, through the "Pressure" slider of the interface, the IT202 at a higher pressure than PR2 and activating the Y1 solenoid of the 5/3 valve, both cylinder roods will travel into "Right" direction. By activating the Y2 solenoid, the cylinder will travel in the "Left" direction. In this way passive movements of the upper limb are possible. When the "MIN Dist." (minimum value of the distance set on the interface) or "MAX Dist." (maximum value of the distance set on the interface) are reached the system automatically changes the direction. In the case of exercises with desired low amplitudes and forces the system reads the encoder, the "MAX Dist." and "MIN Dist" and "Force desired" edit boxes of the interface. The system activates the Y1 and Y2 in accordance with the

displacement and direction and adjusts the force by setting the IT202 output according with the exercises requirements.

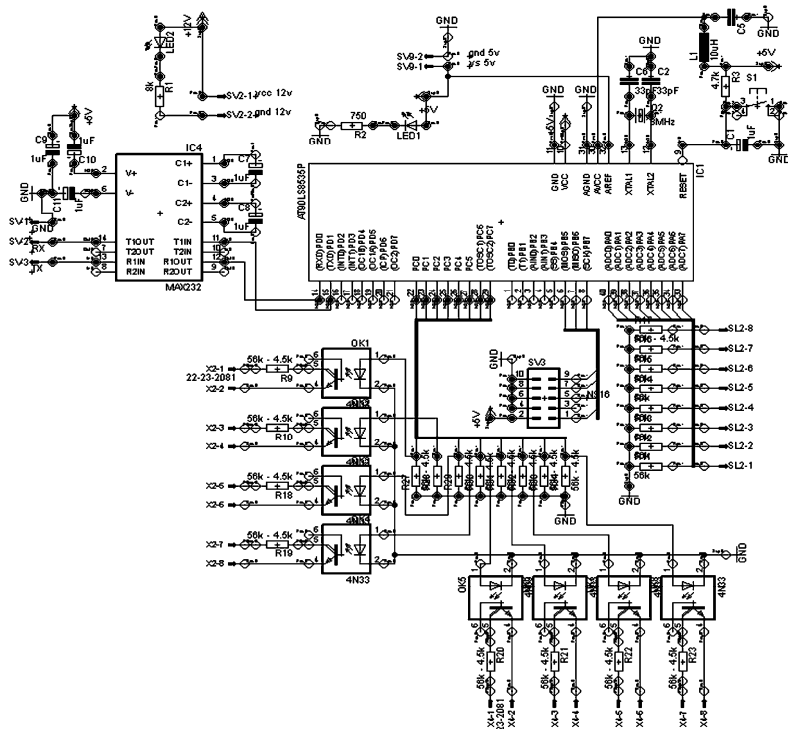

a

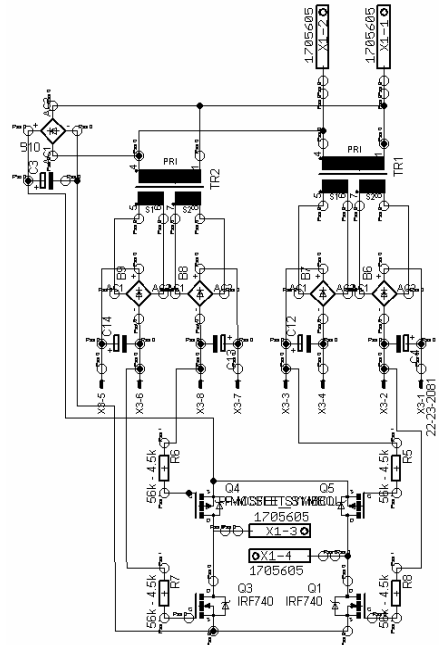

b

Fig. 4. a – The logic board; b – the driving board – electronic scheme

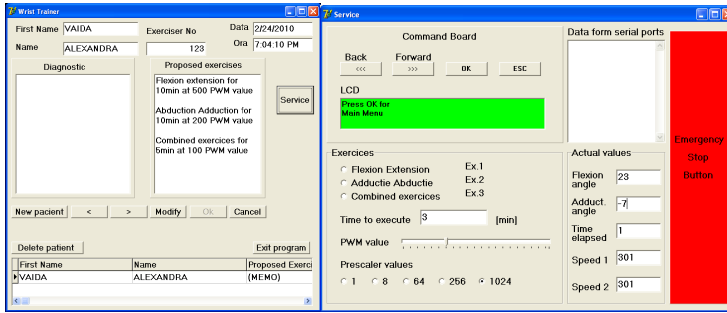

a b  
**Fig. 5.** The interface of the Wrist Trainer



a b  
**Fig. 6.** The work positions of the exerciser

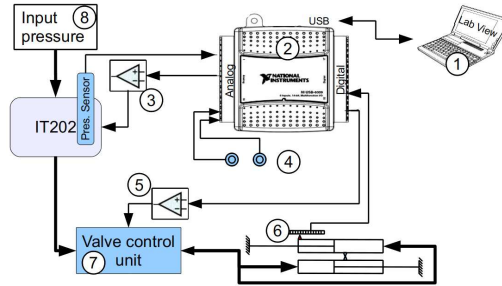

**Fig. 7.** The block diagram of the exerciser

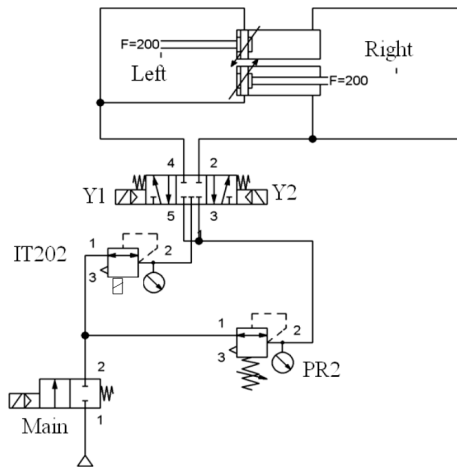

**Fig. 8.** The pneumatic diagram of the exerciser

Lab View 8.6 was used to build the interface of the system (Fig. 9). The program which runs behind this interface allows setting up the type of the exercises, the pressure of the IT202, the force and the distance desired. The interface also offer a visual feed back for the patient by displaying the force and distance read by the sensors. The buttons “Active” / “Passive “ allow the user to set the desired exercises with an interlock function that do not allow the execution in the same time. For counting the travelled distance the program reads a digital input port with a linear encoder attached. Also the program has the capacity to limit the travelled distance. The system will change the travel direction automatically if the maximum or minimum distance, from the afferent edit boxes, is reached. The force desired edit box is used to set a maximum force allowed for the exercise. If this force is reached the system will adjust the IT202 in order to lower the handle force.

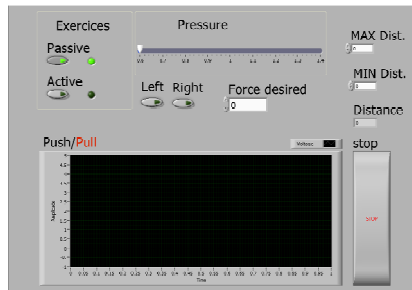

Fig. 9. The interface of the exerciser

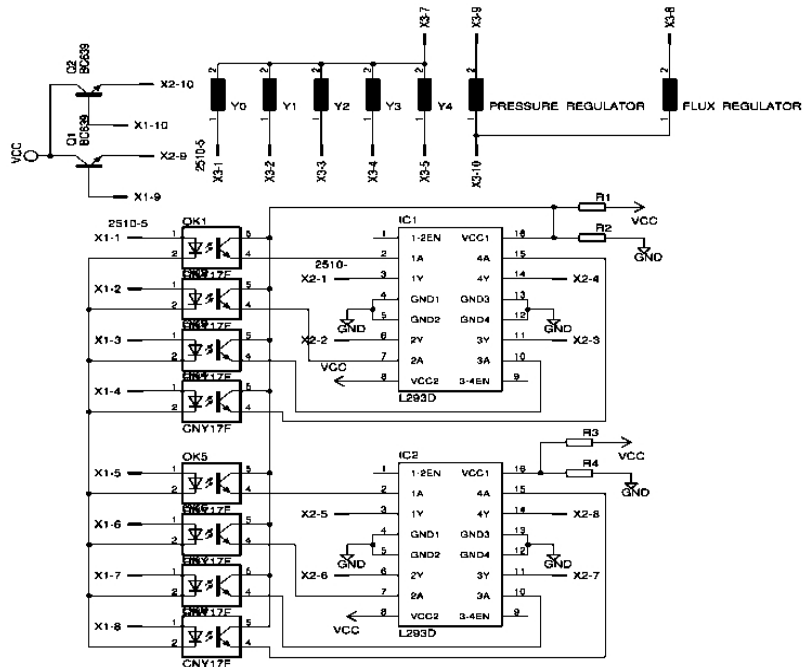
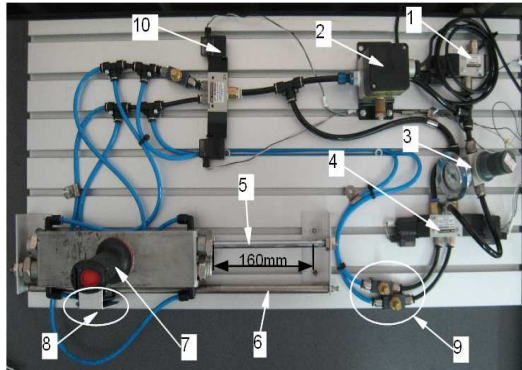

Fig. 10. The amplifiers electrical wiring

Between the NI USB 6009 and the valve control unit, one digital multi-channel amplifier is needed (Fig. 10). It consists from eight optocouplers that allows eight digital inputs and a galvanic separation. At the optocouplers output, two L293 push/pull drivers were used in order to feed the solenoid valves coils with the proper current. The control signal of the IT202

pressure regulator has to be between 0 – 20 mA, according with its data sheet. A BC639 transistor and a different source are used in order to obtain the current signal. The transistor base is connected at the “A0” analogue output channel and the collector is feed with 10V DC from the source. The NI – USB 6009 read two Force Sensing Resistors (FSR) sensors mounted in the handle as well as one optical linear encoder.



**Fig. 11.** The prototype of the linear exerciser

The prototype of the system is given in Fig. 11; the following notations were used: 1 – main valve, 2 – IT202 pressure regulator, 3 – manual pressure regulator, 4 – EVZ5320 5/3 valve, 5 – cylinder rod 160mm stroke, 6 – stability circular beam, 7 – handle mounted on the cylinders case, 8 – encoder and slip bush case, 9 – pneumatic speed controllers, 10 – EVZ5320 5/3 valve. Using the buttons in the interface, the user can switch between active and passive exercises and has the possibility to stop the system in any functioning phase. The forces are varied according to the muscle capabilities of each user. The described exerciser permits a large variety of exercises, which can be accomplished automatically, and modified by programming them.

### **The Analysis of the Developed Prototypes**

The wrist trainer is a rehabilitation system that intends to extend the rehabilitation program at home. It's easy to use and do not need a specially trained person to assist the patient during the exercises. Being self reconfigurable it can be used for both hands, the patient only have to select “right hand” or “left hand” function from the console. With the aid of the interface can be easily followed the rehabilitation evolution. The interface offers precious data as forces, angles, speeds. The mechanical system is designed to be as comfortable as possible and is acting over the interest articulation as the physiotherapist movements, with low speed and the movements are done around the natural articulation axes. The movements are precise and do not allow the patient to do compensatory movements from other articulations to reach his objective. Regarding the possible movements the system can do active and passive movements with low or high forces and speeds that making it useful from the first's steps of the rehabilitation till the final step.

The linear exerciser can be used only in clinics or special rehabilitation centres. It is not difficult to use it, but needs a specially trained person to assist the patient during the exercises. It is not reconfigurable but can be used for both hands, by changing the position of the table. The interface offer a visual feed back of the forces and displacements for the patient as well as for the therapist. The mechanical system is designed to be reliable and easy to maintain. During the performed exercises the whole upper limb is implied in the movement. Regarding the possible exercise, the system can do active and passive movements with low or high forces and speeds that making it useful from the first's steps of the rehabilitation till the final step.



## Conclusions

Recovery, also called rehabilitation, is a complex medical-social process, held for a long period of time, having as objective the reintegration of people with special needs or disabilities into society.

It is now widely approved that recovery processes are more efficient if they are supported by specialized equipment.

Upper limbs are segments of the utmost importance due to their motor and sensorial functions. For this reason, efforts are fully justified to develop rehabilitation systems, specially designed for upper limbs, which permit a wide variety of exercises, with the possibility of parameter changing, customizable for patient needs.

The design and development of the above-described exercisers is an important step towards establishing a convenient and continuously supported rehabilitation environment. The first system presented in this paper is mainly dedicated for the passive exercises; it measures the amplitudes, speeds and forces. The second system is mainly dedicated for active and active with resistance exercises. Currently they are experimentally tested and used as values educational tools. Our future work will be focused on their experimental testing on real users.

## Acknowledgment

This paper is supported by the Project "Doctoral Studies in Engineering Sciences for Developing the Knowledge Based Society - SIDOC" Contract No. POSDRU/88/1.5/S/60078, Project co-funded from European Social Fund through Sectorial Operational Program Human Resources 2007-2013.

## References

- [1] **Raikova R.** A general approach for modelling and mathematical investigation of the human upper limb. *Journal of Biomechanics*, Vol. 25, 1992, p. 857-867.
- [2] **Junji F., Ying J.** A 6-DOF Rehabilitation system for upper limbs "Robotherapist" and other rehabilitation systems with high safety. *Rehabilitation Engineering*, 2009, p. 245-287.
- [3] **Smith J. L., Crawford M., Proske U., Taylor J. L., Gandevia S. C.** Signals of motor command bias joint position sense in the presence of feedback from proprioceptors. *J. Appl. Physiol.*, 2009, Vol. 106, p. 950-958.
- [4] **Hengeveld E., Banks K.** *Maitland's Peripheral Manipulation*. Fourth ed., Elsevier, London, 2005.
- [5] **Sbenghe T.** *Kinetologie Profilactică, Terapeutică și de Recuperare*. Ed. Medicală, București, 1987, (in Romanian).
- [6] **Kahn L. E., Averbuch M., Rymer W. Z., Reinkensmeyer D. J.** Comparison of robot-assisted reaching to free reaching in promoting recovery from chronic stroke. *Integration of Assistive Technology in the Information Age (ICORR)*, Amsterdam, IOS Press, 2001, p. 39-44.
- [7] **Colombo R. et al.** Design strategies to improve patient motivation during robot-aided rehabilitation. *Journal of Neuroengineering and Rehabilitation*, 2007.
- [8] **Mândru D. et al.** Development of robotic systems for upper and lower limbs kinetotherapy. *Acta Electrotechnica*, 48/4, 2007, p. 13-18.
- [9] **Morita Y., Nagasaki M., Ukai H., Matsui N., Uchida M.** Development of rehabilitation training support system of upper limb motor function for personalized rehabilitation. *Proc. of the 2008 IEEE Int. Conf. on Robotics and Biomimetics (ROBIO2008)*, p. 300-305.
- [10] **Hesse S., Schulte-Tigges G., Konrad M., Bardeleben A., Werner C.** Robot-assisted arm trainer for the passive and active practice of bilateral forearm and wrist movements in hemiparetic subjects. *Arch. Phys. Med. Rehab.*, 84, 2003, p. 915-920.
- [11] **Chetran B. et al.** Wearable exerciser. *Solid State Phenomena*, 166-167, 2010, p. 115-120.
- [12] **Chetran B. et al.** Rehabilitation exercisers – from simple devices to robotic systems. *Acta Technica Napocensis*, 2011, (in press).