

## 698. Research of dynamic characteristics of piezoelectric actuator used in flow control device

R. P. Bansevicius<sup>1, a</sup>, R. Rimašauskienė<sup>2, b</sup>, M. Rimašauskas<sup>1, c</sup>

<sup>1</sup> Kaunas University of Technology, Kęstučio str. 27, LT-44312, Kaunas, Lithuania

<sup>2</sup> The Szewalski Institute of Fluid-Flow Machinery, Polish Academy of Sciences, Fiszerza str. 14, 80-231, Gdansk, Poland

**E-mail:** <sup>a</sup> [ramutis.bansevicus@ktu.lt](mailto:ramutis.bansevicus@ktu.lt), <sup>b</sup> [ruta.rimasauskiene@gmail.com](mailto:ruta.rimasauskiene@gmail.com), <sup>c</sup> [marius.rimasauskas@ktu.lt](mailto:marius.rimasauskas@ktu.lt)

**Phone:** +370300910; **Fax:** +370300910

(Received 23 August 2011; accepted 4 December 2011)

**Abstract.** Novel flow control device, which functionality is based on piezoelectrical actuator and special membrane is proposed in this paper. The membrane is composed from two gratings. Rotating one of the control membrane plates with micro pores generates effects that are exploited for control of flow. Traveling wave piezoelectric actuator of rotary type is studied experimentally in this paper.

**Keywords:** flow control, piezoelectric actuator, piezoelectricity.

### Introduction

The throughput of light, liquid, and gas flows has been measured for a long time. Drinking water was the very first measured resource. Now measurement of various flows is a common procedure. Measurement is performed for two basic purposes. First, it aims to define quantities of various liquids and gasses that flow through various systems. This is important for calculation of amounts to be paid for consumed quantities of measured resource. Second, flows, especially those of various technological processes, are measured aiming to identify and control their fluctuations warning about deviations with respect to predefined values [1]. In order not only to measure but also to control flows of various magnitudes, it is necessary to select a suitable flow control equipment.

The category of flow control and transmission products involves wide range of devices designed aiming to support control and measurement processes in various flows, i.e. identifying parameters of flows running through a pipe or a hose in a system. Running material may be light, gas, liquid, or semi-solid substance. Flow control and transmission devices may be divided in the following groups: ordinary valves, air flow positioning valves, batchers, pumps, flow parameter taking equipment, etc. [2-5].

As it is known, flow control and transmission is more widely performed with a help of mechatronic systems, especially those that involve active materials.

Currently, PZT ceramics is the most popular piezoelectric material, though voltage, motion, and force values obtained with the help of it are rather small. PZT ceramics is widely used in precise engineering that demands accurate and minor motions, quick action, short response times, and possibility of operating in a specific environment. Since flow control devices require highly accurate motions (turns) and quick action, in order to precisely and quickly control the flow, it is relevant to use actuators made from this material.

Piezoelectric actuator is a device designed for transforming electric energy into mechanical one (turn). Its performance characteristics influence speed and accuracy of turning the membrane plate. As it is known, characteristics of the piezoelectric actuators are mostly suitable for designing micro flow control equipment due to their quick action, resolution, wide range of possible outer sizes, relatively low price, and similar characteristics.

Piezoelectric effect started to be implement in various engineering areas more widely after mastering processes of synthesizing and manufacturing piezoelectric materials. Yet in 1964, US

registered the first patents of using characteristics of piezoceramic materials for transportation and dosage of liquids [6].

Researchers of Kaunas University of Technology have patented a number of flow control equipment with piezoelectric actuators. They were designed for batching of various liquids and control of flows [7-8]. These inventions may be widely used in mono disperse technologies, i.e. manufacture of micro granules, forming micro doses of various liquids; in pharmacy, biological processes, or space equipment.

This article delivers experimentally identified dynamic characteristics of piezoelectric actuator in fast-response flow control system. This system functions on the basis of interference between piezoelectric actuator and moiré gratings. moiré effect is created in between two micro pored (or notched) plates in flow control membrane. moiré image changes when one of the plates is turned at a certain angle. By this way, the flow is closed, opened, or intermediary stages are obtained. In order to suitably chose flow control membrane plates and control the flows, it is necessary to know dynamic characteristics of piezoelectric actuators.

### Design of flow control device

The scheme of flow control device presented in Figure 1 has been developed and patented [9] at Kaunas University of Technology.

The flow control device consist of a cylindrical body 1, mounting ring 2 that is rigidly entrenched in it. Ring 2 is used like a support of piezoceramic actuator (cylinder) 3. On the piezoceramic actuator 3 is loaded mounting ring 4 of the plate with a pad. The plate 5 with micro pores or notches is glued on the mounting ring 4. Another mounting ring 7 is threaded and plate 6 is rigidly entrenched on it, then both of them are screwed on the cylindrical body 1. A center-tab 8 fastened on cross-plates, and their mutual compression is adjusted on mounting ring 7 threaded support. From the plates (with micro pores or notches) 5 and 6 is formed the flow permeability regulating membrane.

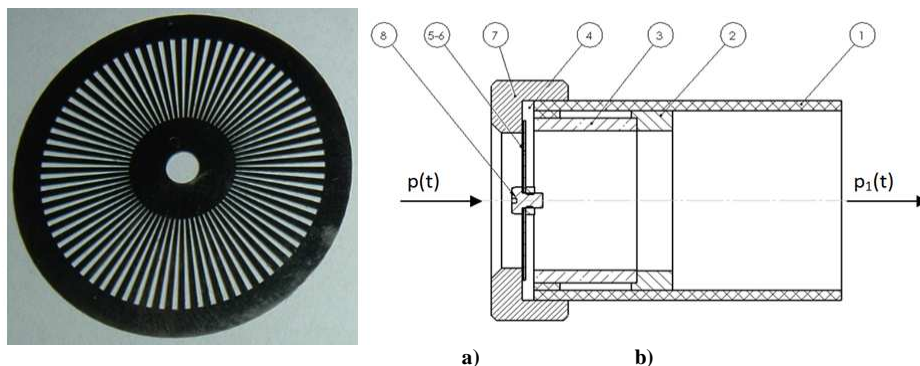

**Fig. 1.** The flow control device: a) plate with notches; b) scheme: 1 – cylindrical body; 2 – mounting ring; 3 – piezoceramic actuator (cylinder); 4 – mounting ring of the plate with a pad; 5 – plate; 6 – plate; 7 – threaded mounting ring; 8 – center tab

The principle of operation can be explained as follow. Traveling deformation waves are generated on piezoceramic actuator (cylinder) 3 and mounting ring 4 with glued plate 5 in contact with the actuators output link can be rotated by the clockwise direction or against it.

During the initial operation at the time of the plate 5 and 6 is geometrically adjusted so that the adjacent micro pores or notches do not overlap and flow control membrane permeability would be minimal or zero. Optical moiré interference pattern is generated as the geometric location of the adjacent micro pores or notches of the two plates change when one of the plates rotates. This interference effect alters the flow permeability. When piezoceramic actuator is

driven, it generates traveling deformation waves and optical moiré interference pattern is induced between two plates 5 and 6.

### Scheme of the piezoelectric actuator for rotary motion in flow control device

The paper experimentally investigated cylindrical piezoelectric actuator (Fig. 2), whose dimensions are:

$D = 35$  outer diameter [mm];  $d = 28$  inner diameter [mm];  $L = 20$  pipe length [mm];  
 Material - CTS-23 (produced in Russia).

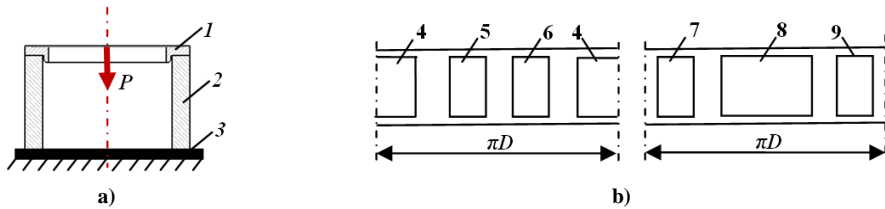

**Fig. 2.** Piezoceramic cylinder with a steel ring: a) general scheme, b) involutes of a cylindrical inner and outer surfaces (single phase). 1 - steel ring, 2 - piezoelectric cylinder with electrodes formed on the outer and inner surfaces of the cylinder, 3 - vibration-attenuation substance, 4, ..., 9 - electrode configuration

The actuator for flow control device was selected, whose has a piezoelectric cylindrical inner and outer surfaces divided into three segments, two of  $90^\circ$  and one  $180^\circ$ , the outer and inner opposite electrode ( $180^\circ$ ) is connected with each other, the other two electrodes ( $90^\circ$ ) is connected in the opposite two and between their is connected condenser (Fig. 2). Thus, combining piezoelectric cylindrical electrodes formed unsymmetrical output unit running wave type oscillations. By moving the second phase of the harmonics  $180^\circ$  or the first  $90^\circ$  to each other can be obtained the reverse of actuators output link.

### An experimental study of dynamic characteristics of cylindrical actuators

Experiments were carried to find out voltage and frequency, which will allow to achieve the largest output link shift of piezoelectric actuators (cylinder).

In order to determine these parameters the experiments were carried out by using an experimental setup (Fig. 3), which consists of a programmable signal generator Agilent 33220, high-voltage amplifier with 1-150 kHz frequency range, multimeter Mastech 8218, laser.

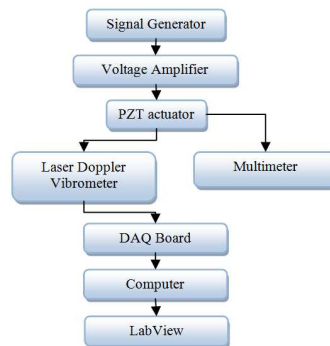

**Fig. 3.** Block diagram of experimental setup used for the measuring of dynamic characteristics of the cylindrical piezoactuator

Doppler vibrometer from Polytec ( $V_{max}=10$  m/s, frequency zone 0.5 Hz - 1.5 MHz; resolution from 0.1 to 2.5 (mm/s)/ $\sqrt{\text{Hz}}$ ), analog capture card (National Instruments PCI 5102, 20 MS/s) and a computer with installed LabView software.

For the collection and processing of measurement data a program was made in LabView graphical programming environment, allowing to receive the amplitude frequency characteristics of the experimental output link.

Laser vibrometer in conjunction with the LabView program were used to determine the dependence of the frequency shift. During experiments the excitation voltage of 10 V was kept constant, frequency was varied and the shift of the output link of the actuator was measured.

Dependence in Fig. 4 indicates that the greatest displacement improvements are achieved at resonant frequencies (51.94 kHz and 93.8 kHz).

The same experimental setup (Fig. 3) was used to determine the resolution of the flow control device with piezoelectric actuators (cylinder shape). Displacements of reference point were measured in the following way: an output link of the piezoelectric cylinder was fitted with a steel ring, in which plate with micro pores was rigidly fixed. Then a piece was fixed on the steel ring as the starting point. The measurement data was collected and processed by LabView program, which allowed to receive the amplitude of the reading point. After the experiment, the shifts of reading point have been converted into the angular degrees.

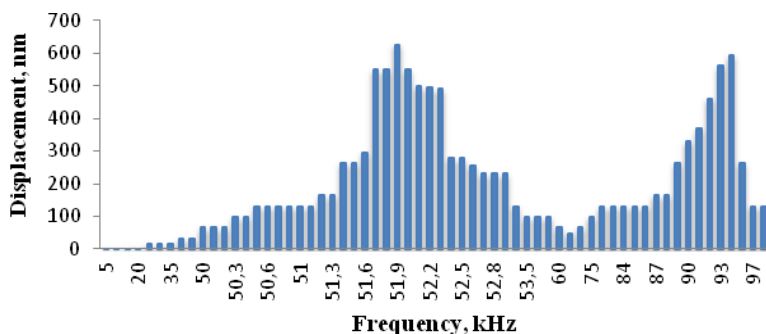

Fig. 4. Dependence of the displacement with respect to frequency (voltage 10 V)

Investigation of flow control device resolution was used the package, which contains some number of periods of harmonic signal ( $U_{RMS}=56$  V,  $f=51.94$  kHz or  $f=93.4$  kHz). Shift dependence on harmonic number of signal cycles package are presented in Fig. 5.

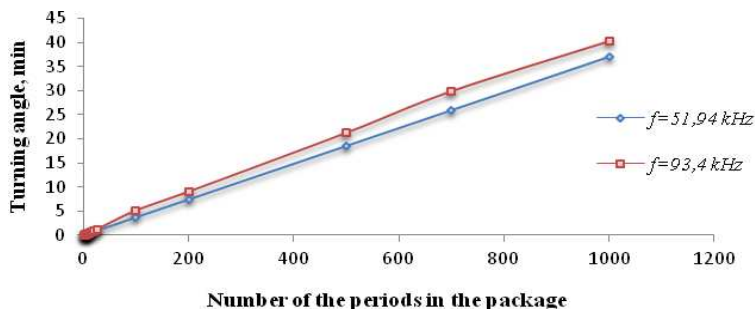

Fig. 5. Turning angle dependence on the number of periods in the package. Harmonic signal amplitude  $U_{RMS}=56$  V, frequency  $f=51.94$  kHz and  $f=93.4$  kHz

The rotor starts to rotate after forming two harmonic signals whose amplitude  $U_{RMS}=56$  V and frequency  $f=51.94$  kHz or  $f=93.4$  kHz for periods of package, the transition process ended after 12 ms from the end of the excitation package. After recalculating the displacement in turn was received a resolution of 0027', the second case - 0029'.

Another experiment was conducted to determine the dependence of speed  $v$  of the steel ring (which is in contact with the output link) as a function of load  $P$ . These data are necessary in order to find out what the maximum power available to operate the plate with notches, which is tightly fixed in steel ring at a time when through a membrane of flow control device will flow gas or liquid.

Experimental setup is shown in Fig. 6. The experiment was maintained at a constant excitation voltage of  $U=56$  V, and its size was monitored during the experiment with multimeter Mastech 8218. The resonant frequencies of piezoceramic cylinder were changed by support of the control unit (programmable signal generator Aligent 33220 and high-frequency voltage amplifier EPA-104). The weights were used as the load mass  $m$  during the experiment, by stopwatch was measured the rotation number ( $n=20$ ) per time  $t$  of the steel ring wig tightly fixed plate with micro pores.

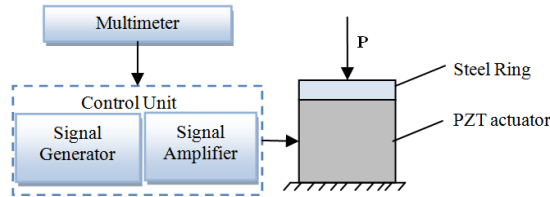

Fig. 6. Experimental setup

Dependence of fixed angular velocity  $v$  on loading force  $P$  at resonance frequency of 51.6...52.3 kHz (Fig. 7) and 93.2...94 kHz (Fig. 8), when the excitation voltage is constant at  $U=56$  V.

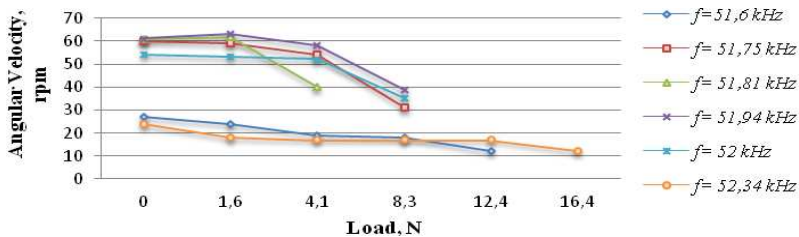

Fig. 7. Angular velocity dependence on the load (resonant frequencies of 51.6...52.34 kHz,  $U=56$  V)

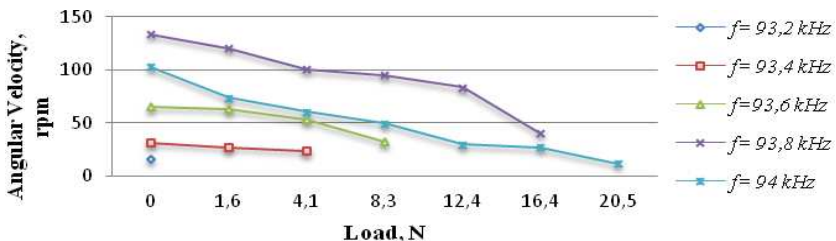

Fig. 8. Angular velocity dependence on the load (resonant frequencies of 93.2...94 kHz,  $U=56$  V)

It was determined (Fig. 7) that piezoelectric actuators can work at resonant frequencies 51.6...52.34 kHz when the maximum load is achieved, but throughput is at least about 10 revolutions per minute. The maximum throughput of the actuator is achieved by working at resonance frequency of 51.94 kHz.

At a same time when the piezoelectric actuators are working under the second operating frequency range (Fig. 8), the maximum throughput is obtained at 93.8 kHz. Resonant frequency at which operation can be achieved with a maximum load is 94 kHz, but the throughput is lower.

## Conclusions

1. The article presents authentic patented work layout of flow control device. The flow might be controlled, or motion in three-dimensional space is created, using moiré effect produced between two micro pored (or notched) plates in flow control membrane.
2. It was established that non-symmetrical running wave fluctuations in a cylinder outflow form due to the different excitation rates, after choosing configuration of electrode set up and performing experimental research. The most suitable working regimes are obtained at 51.94 kHz and 93.4 kHz.
3. Experimentally determined dynamic characteristics of cylindrical piezoelectric actuator demonstrated that this actuator is suitable for performing turning motion of membrane plate in flow control device. Under different resonance rates, plate turning resolution of  $0.027^{\circ}$ - $0.029^{\circ}$  was obtained. Depending on the rate, unloaded plate may reach speed of 60-140 rpm.

## References

- [1] **Pedišius A., Tonkonogij J., Ilgarubis V.** Metrology in Energetic. [previewed 2009-09-15] Available at: <http://ausis.gf.vu.lt>.
- [2] **Morita T.** Miniature piezoelectric motors. *Sensors and Actuators A: Physical*, Vol. 103, No. 3, 2003, p. 291-300.
- [3] **Garcia-Bonito J., et. al.** A novel high-displacement piezoelectric actuator for active vibration control. *Journal of Smart Materials and Structures*, Vol. 7, No. 1, 1998, p. 31-42.
- [4] **Uchino K.** Piezoelectric ultrasonic motors: overview. *Journal of Smart Material and Structures*, Vol. 7, No. 3, 1998, p. 273-285.
- [5] **Schroth A., Maeda R., Akedo J., Ichiki M.** Application of Gas Jet Deposition Method to Piezoelectric Thick Film Miniature Actuator. *Japanese Journal of Applied Physics*, Vol. 37, No. 9B, 1998, p. 5342-5344.
- [6] **Dong S., Zang J., Kim W., and et al.** Flexural Traveling Wave Excitation Based on Shear-Shear Mode, *IEEE transactions and ultrasonic, Ferroelectrics, and Frequency Control*, Vol. 51, No.10, 2004, p. 1240-1246.
- [7] **Bansevičius R., Bubulis A., Jūrėnas V., Pilkauskas K.** Micro-pump dispenser, LR patent, LT 5361, 2006 10 25.
- [8] **Bansevičius R., Bubulis A., Jūrėnas V., Pilkauskas K.** Piezoelectric fluid flow regulator, LR patent LT 5366 B, 2006 10 25.
- [9] **Bansevičius R. P., Mitrulevičiūtė R., Ragulskis M. K.** Device of the flow control, patent application No. 2007 006 / inventors: Ramutis Bansevičius, Rūta Mitrulevičiūtė, Minvydas Ragulskis; applicant: Kaunas University of Technology, 20081229. p. 7.