

528. Bend with compression of thin-layer rubber-metal elements

V. Gonca^a, J. Shvab^b, J. Viba^c

Riga Technical University, Ezermalas 6, LV-1006, Riga, Latvia

e-mail: ^aVladimirs.Gonca@rtu.lv, ^bJuris.Svabs@rtu.lv, ^cJanis.Viba@rtu.lv

Phone: +371-67089473

(Received 20 October 2009; accepted 27 November 2009)

Abstract. For efficient application of thin-layer rubber-metal elements (TLRME) in modern mechanical engineering, including vibration insulation, it is necessary to determine ruggedness characteristics of TLRME. Numerous experimental studies have demonstrated that at tension and compression this characteristic is influenced essentially by value of specific load, compliance of non-elastomeric layers and way of fastening of elastomeric layers in the TLRME package. In the present article the calculation method of ruggedness constant of TLRME is presented at static load, tension - compression, in the field of small deformations taking into account the deformation of a glutinous layer. The solution is obtained by the method of Ritz using the principle of the minimum complete potential energy of deformation. The obtained solution allows to obtain asymmetrical ruggedness constant of TLRME at tension - compression without the assumption regarding dissimilar modularity of rubber.

Keywords: rubber, shock-absorber, rigidity, weak compressibility.

Introduction

Multi-layer thin-layer rubber-metal shock-absorbing elements (further – TLRME) are widely used in various fields of mechanical and civil engineering ($\rho = a/h \gg 10$, a – is a typical geometrical dimension in the design project; h – is a width of rubber layer), and have lots of structural advantages, in particular, they ensure greater rigidity under axial compression and lower rigidity under shift and spinning. In such constructions very thin metal layers are used as supporting intermediate layers, to which rubber layers are attached by vulcanization.



The calculations of rigid dependencies (of the type “Force - Settlement”) for such thin-layer metal elements being pressed and by using already classic solutions [2 – 6], demonstrated that there is inherent difference between the calculated values and the experimental data, when layers of works [5, 6] have certain geometrical dimensions. At the same time, the closer Poisson coefficient is to 0.5 and the thinner are rubber and supporting layers in compensating elements, the greater is the divergence. The result of experimental studies [5, 6] of such elements being compressed is that the rigid feature of multi-layer compensating elements is considerably influenced by: low compressibility of rubber material, especially, when Poisson coefficient of rubber changes within $0,480 \div 0,499$; deformation of supporting layers being sufficiently thin.

To ensure safe performance and when designing thin-layer rubber-metal compensating devices, it is necessary to obtain analytical dependence for rigid feature “Force – Settlement” of such kind of elements. It is only possible having the correct design model, which will enable us

taking into account and estimating all the geometrical parameters as well as physical and mechanical features of materials of the considered elements.

Variety of application of TLRME based on number of degrees of freedom is given in Table 1.

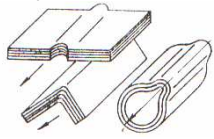
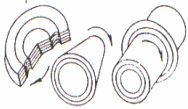
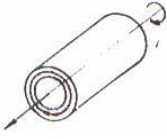
Table 1. Classification of TLRME by number of degrees of freedom

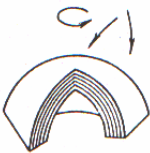
Quantity of angular degrees of freedom	Quantity of linear degrees of freedom (in the table - DF)			
	0	1	2	3
0		DF ₁₀ 	DF ₂₀ 2DF ₁₂	DF ₃₀ 3DF ₁₀
1	DF ₀₁ 	DF ₁₁ 	DF ₂₁ 	DF ₃₁ DF ₂₁ +DF ₁₀ or DF ₁₁ +2DF ₁₀
2	DF ₀₂ 2DF ₀₁	DF ₁₂ 2DF ₀₁ +DF ₁₀	DF ₂₂ 2DF ₀₁ +2DF ₁₀ or DF ₂₁ +DF ₀₁	DF ₃₂ 2DF ₀₁ +3DF ₁₀ or DF ₂₁ +2DF ₀₁
3	DF ₀₃ 	DF ₁₃ DF ₀₃ +DF ₁₀	DF ₂₃ DF ₀₃ +2DF ₁₀	

In connection with advances of information technology in the field of control and steering of electromechanical systems, inventors and scientists pay particular attention to development of underwater robots. To this theme is devoted the work on studying and creation of the robot of fish [1].

In given work as object probes fish of the form of a salmon (Fig. 1 – 5 is accepted.) <http://www.earthlife.net/fish/> [1, 2]. The main idea of probes consists that there is a possibility to replace the reinforced muscles of TLRME (Fig. 2 – 3). Elements of muscles of fish are shown in Fig. 1 and Fig. 2 [2].

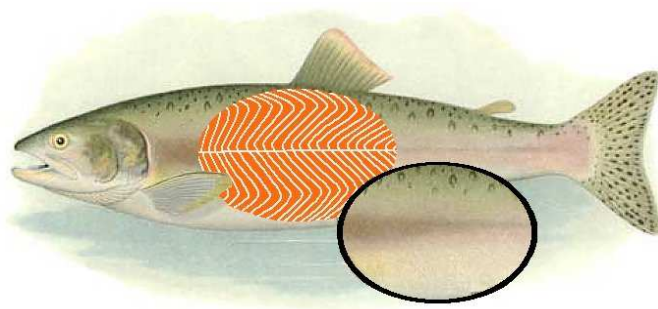

Fig. 1. A salmon: the case, a tail and fins



Fig. 2. Sections of a salmon. In conditional section it is possible to observe red and white muscles of fish

It is not excluded that in robotics muscles can be replaced by TLRME, with a special control system of internal forces.

In the project [1] it is supposed to use excitation of the robot from the power supply of the internal forces, located in the main case of the robot (head) (Fig. 3, 4). Ideas of excitation of movement of the robot by internal nonlinear interactions and by nonlinear external interactions are presented in Fig. 5.

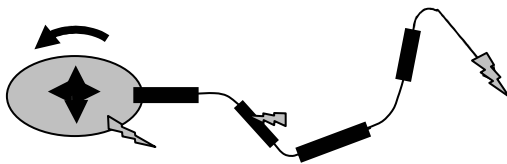

Fig. 3. The general scheme of the robot of fish with passive fins and with active remote or adaptive excitation of the case

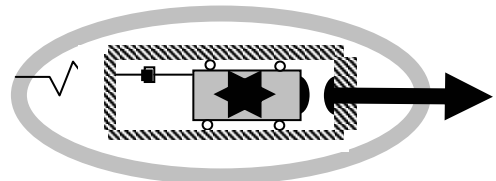

Fig. 4. Possible active excitation of the robot from shock-vibrating interactions in the case of fish

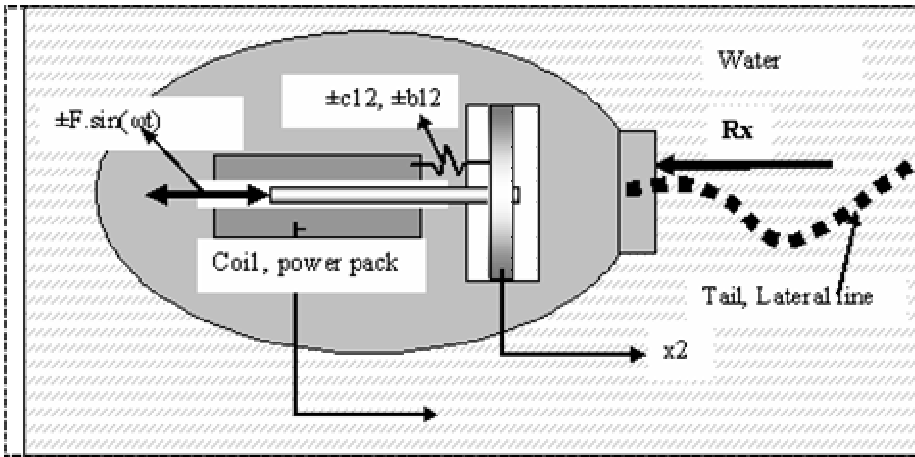

Fig. 5. Scheme of unicomponent excitation of a tail of the robot

Unique conveyance of the case probably only in the presence of nonlinearity of force R_x , which can be received TLRME. Thus the probe overall objective is directed on studying of possibilities of using TLRME in creation of the case, a tail and fins of the robot of fish. As the study of problem of TLRME in space of three co-ordinates and time with complicated steering and boundary conditions is highly complex only the one-dimensional problem of the analysis of forces of a static TLRME of a tail of the robot is considered in this paper.

Considering that for TLRME the shift ruggedness in some applications is less than ruggedness at axial compression, in this work we propose one of the design models for analytical calculation of rigid feature of multi-layer compensating elements being compressed, which enables taking into account low compressibility of material of rubber layers and deformation of non-elastomeric supporting layers.

Materials and methods

The method of obtaining analytical dependence “Force - Settlement” of multi-layer compensating element under axial compression is considered. Only small deformations are investigated. Application of the proposed method is demonstrated by the example of designing multi-layer shock-absorber, which consists of thin flat rectangular elements.

The geometrical design model is illustrated in Figs. 6 (a)-(b).

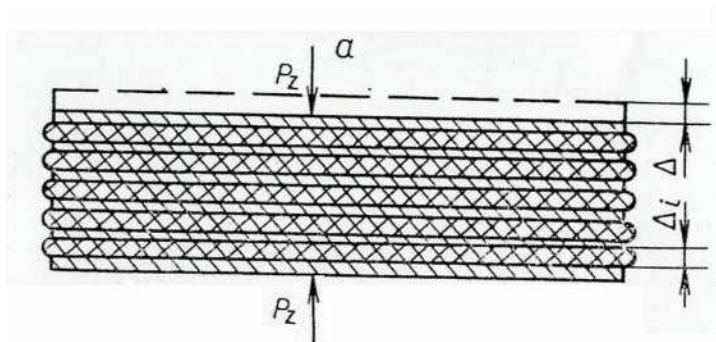

(a)

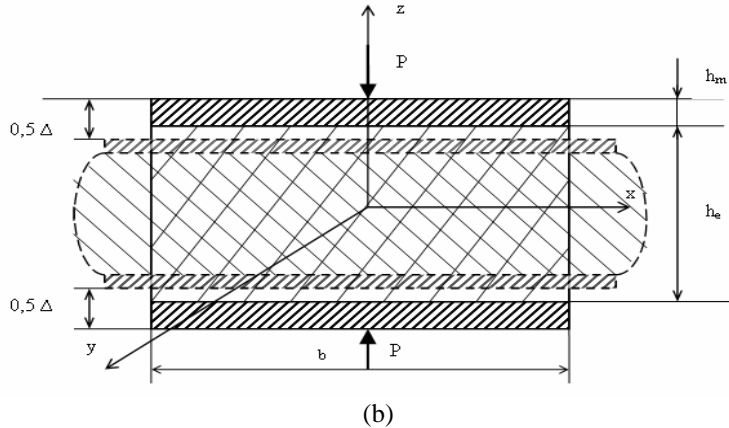

Fig. 6. Computational model: (a) - shock absorber. (b) - n^{th} - layer of shock absorber

Proposed method uses the variational method, which is based on the principle of minimal potential energy [1, 8] for low compressible material. The potential energy of the studied element in case of small deformations is expressed as:

$$J = \sum_{l=1}^{l=n} G \int_V \left[(\varepsilon_{xx}^2 + \varepsilon_{yy}^2 + \varepsilon_{zz}^2 + 2(\varepsilon_{xz}^2 + \varepsilon_{yz}^2 + \varepsilon_{xy}^2)) + \frac{3\mu}{1+\mu} S(\varepsilon_{xx} + \varepsilon_{yy} + \varepsilon_{zz}) - \frac{9\mu(1-2\mu)}{4(1+\mu)^2} S^2 \right] \cdot dV - P\Delta \quad (1)$$

where: G – modulus of rigidity for each layer; μ – Poisson coefficient of material of each rubber layer; P – longitudinal force of compression; Δ – settlement of the entire element; s – hydrostatic pressure function in each layer; u, v, w – displacements of randomly chosen point in each layer, respectively, in directions x, y, z ; V – volume of each layer. The summing up is carried out for all rubber and non-elastomeric layers of a multi-layer element.

Deformations ε_{ij} in each layer are found using the following formulae:

$$\varepsilon_{xx} = \frac{du}{dx}; \quad \varepsilon_{yy} = \frac{dv}{dy}; \quad \varepsilon_{zz} = \frac{dw}{dz}; \quad (2)$$

$$\varepsilon_{xy} = \frac{1}{2} \left(\frac{du}{dy} + \frac{dv}{dx} \right); \quad \varepsilon_{yz} = \frac{1}{2} \left(\frac{dv}{dz} + \frac{dw}{dy} \right); \quad \varepsilon_{zx} = \frac{1}{2} \left(\frac{du}{dz} + \frac{dw}{dx} \right);$$

The potential energy for the entire element is calculated by summing up formula (1) for all rubber and non-elastomeric layers. Physical and mechanical features of the material layers and geometrical parameters of layers have such indexes: e – for rubber layers; m – for non-elastomeric layers.

In order to use functional (1) when choosing functions of displacements $u(x, y, z), v(x, y, z), w(x, y, z)$ and functions of hydrostatic pressure $s(x, y, z)$, it is enough to fulfill geometrical boundary conditions and the conditions of coupling rubber and non-elastomeric layers for

displacement functions. For simplicity let us suppose all the layers have same dimensions in the design (a and b), all the rubber layers have width h_e , and the non-elastomeric layers have width h_m . For the considered problem the necessary geometrical conditions are:

$$\begin{aligned} w_e(x,y,0.5h_e) &= -0.5\Delta; \quad w_e(x,y,-0.5h_e) = 0.5\Delta; \\ u_e(x,y,\pm 0.5h_e) &= u_m(x,y,\pm 0.5h_e); \quad v_e(x,y,\pm 0.5h_e) = v_m(x,y,\pm 0.5h_e). \end{aligned} \quad (3)$$

When writing displacement functions analytically let us suppose that: for rubber layers the hypothesis of plane sections is valid; for non-elastomeric layers the condition of homogeneous deformation is fulfilled. In this case, taking into account the geometrical conditions (3), the desired displacement functions can be chosen in the form for:

- rubber layers:

$$\begin{aligned} u_e &= C_1 x (z^2 - h_e^2/4) + K_1 x, \quad v_e = C_2 y (z^2 - h_e^2/4) + K_2 y, \\ w_e &= -C_3 (z^3/3 - zh_e^2/4)/h_e^3 - C_4 z, \quad s_e = C_5 (z^2 - h_e^2/4), \end{aligned}$$

- non-elastomeric layers:

$$u_m = K_1 x, \quad v_m = K_2 y, \quad w_m = s_m = 0 \quad (4)$$

where: $C_1, C_2, C_3, C_4, C_5, K_1, K_2$ – are unknown constants, which can be found using the settlement of the element Δ from the minimum condition of full potential energy of deformation (1) of the entire element:

$$\frac{\partial J(C_1, C_2, C_3, C_4, K_1, K_2)}{\partial (C_1, C_2, C_3, C_4, K_1, K_2)} = 0 \quad (5)$$

Δ – the desired unknown settlement of the element, which, by using equations (3) – (5), can be found from the equation:

$$\Delta = -C_3 h_e^3/6 + C_4 h_e. \quad (6)$$

From algebraic equation system (5) and (6) for the considered element the desired dependence "Force – Settlement" can be written as:

$$\Delta = \frac{P h_e n}{2,5 G_e a b} \frac{1 + 1,25 \frac{B_1 B_2}{\chi(B_1 + B_2)}}{1 + \frac{B_1 B_2}{B_1 + B_2 + \frac{1 - 2\mu}{\mu} B_1 B_2}} \quad (7)$$

where:

$$\begin{aligned} B_1 &= 1 + \frac{5 \alpha^2}{12}; \quad B_2 = 1 + \frac{5 \beta^2}{12} \\ \alpha &= \frac{a}{h_e}, \quad \beta = \frac{b}{h_e}, \quad \chi = \frac{G_m h_m}{G_e h_e} \end{aligned} \quad (8)$$

a, b, h_e, h_m – geometrical parameters of flat rectangular rubber and non-elastomeric layers;

G_e , G_m – modulus of rigidity of material, respectively, of rubber and non-elastomeric layers; n – number of rubber layers in the packet.

If rubber and non-elastomeric layers have different dimensions, which let us ignore the low compressibility of rubber layers and flexibility ($h_e < h_m$, $G_e \ll G_m$, parameter $\chi \rightarrow \infty$) of non-elastomeric layers, then from formula (7) we obtain dependence for element settlement:

$$\Delta_0 = \frac{Ph n}{2,5 G ab} \frac{1}{1 + \frac{\alpha^2 \beta^2}{\alpha^2 + \beta^2}}, \quad (9)$$

which coincides with the dependence “Force - Settlement”, obtained in work [3] without taking into account the compressibility of rubber and deformation of non-elastomeric layers.

Results

From formula (7) it follows that neglecting of deformation of non-elastomeric layers when determining settlement of the element may lead to significant quantitative errors. As an example let us consider the element of such geometry:

$$a = b = 8 \text{ cm}, h_e = 0,2 \text{ cm}, G_e = 10 \text{ kg/cm}^2, h_m = 0,02 \text{ cm}, G_m = 2,8 \times 10^5 \text{ kg/cm}^2.$$

From (7) for the desired settlement Δ of the element and taking into account deformation of non-elastomeric layers we obtain the expression:

$$\Delta = \left[1 + 1,25 \frac{B_1 B_2}{\chi(B_1 + B_2)} \right] \Delta^* = 1,298 \Delta^*, \quad (10)$$

where:

Δ^* - settlement of the element (see (10)) only taking into account low compressibility of rubber layer and neglecting deformation of non-elastomeric layers. It is obtained in [3, 10] and is the particular case of formula (7).

The numerical values are quite well described by formula (9) for the experimental results of work [6]. In the considered example neglecting deformation of non-elastomeric layers leads to underrating the value of element settlement approximately per 30%.

If the geometry of thin-layer element is such that it is possible to neglect only flexibility of non-elastomeric layers, then from formula (7) for settlement of element follows the dependence:

$$\Delta^* = \frac{Ph n}{2,5 G ab} \frac{1}{1 + \frac{B_1 B_2}{B_1 + B_2 + \frac{1-2\mu}{\mu} B_1 B_2}}. \quad (11)$$

It can be recommended, using the results of experiment under axial compression for multi-layer element, with quite rigid non-elastomeric layers, to obtain Poisson coefficient of rubber material. This problem for low compressible material formulated in [7] requires complicated experimental technique, and application of formula (11) allows us to apply fairly simple experimental investigation.

Conclusion

Reported study proposes a method for determination of rigidity dependence “Force – Settlement” for multi-layer shock-absorbing elements being under pressure and enables taking into account low compressibility of material of rubber layers and deformation of non-elastomeric layers. The considered method is relatively simple when using it for thin-layer elements of any configuration. The method provides more thorough analysis of ready elements and allows us to make decisions on optimal design of thin-layer shock-absorbing elements more effectively.

References

- [1] Robotic Fish Locomotion and Sensing. Project acronym: FILOSE 2008. SEVENTH FRAMEWORK PROGRAMME. Challenge 2: Cognitive Systems, Interaction, Robotics. STREP.
- [2] <http://www.earthlife.net/fish/>.
- [3] Лавендел Э. Э. Расчеты резинотехнических изделий. М., 1976. 230 с.
- [4] Дымников С. И., Лавендел Э. Э., Павловскис А.-М., Сниегс М. И. Прикладные методы расчета изделий из высокоэластичных материалов. Рига: Зинатне, 1980.
- [5] Dymnikov S. I., Lavendelis E. E. Diagram's of calculations of compression of rubber shock absorber of large course. – *Scientific Proceedings of IUTAM/IFTOMM Symposium “Elastomers'99”*, Dnepropetrovsk, Ukraine, 1999, p.37.
- [6] Dymnikov S. I., Lavendelis E. E. Calculations of rigidity of rubber elastic elements of arched and conical rubber-metal shock absorbers. – *Scientific Proceedings of Riga Technical University. Series 6: Transport and Engineering*, 2002, vol.7 (Mechanics), Riga, pp.164 – 169.
- [7] Лейканд Н. А., Лавендел Э. Э., Горелик Б. М. и др. Экспериментальное исследование констант упругости резин 2959 и 51-1673. - В кн.: Всес. науч.-техн. конференция по методике расчета изделий из высокоэластичных материалов. Рига, 1980, с. 142 - 143.
- [8] Гусятинская Н. С. Применение тонкослойных резинометаллических элементов в станках и других машинах. М., 1978. 80 с.
- [9] Euler M., Beigholdt H.-A. Ermittlung von Kriechfunktionen fur das viskoelastische Materialverhalten von Holf im Zugversuch / LACER No.4, Universitat Leipzig, 1999 - p.319-334.
- [10] Гонца В. Ф. Влияние слабой сжимаемости на решение задач теории упругости для несжимаемого материала. «Вопросы динамики и прочности». Рига, 1970, вып. 20, с. 185-189.