

## 298. Dynamics of tactile device drive

M. Azubalis<sup>1</sup>, V. Grigas<sup>2</sup>, A. Palionis<sup>3</sup>, R.-T. Tolocka<sup>4</sup>

<sup>1, 2, 3, 4</sup> Kaunas University of Technology, Department of Power Systems,  
Studentų, 48, Kaunas, LT - 51367, Lithuania

<sup>1</sup> E-mail: [mindaugas.azubalis@ktu.lt](mailto:mindaugas.azubalis@ktu.lt), +370 37 300281

<sup>2</sup> E-mail: [vytautas.grigas@ktu.lt](mailto:vytautas.grigas@ktu.lt), +370 37 204798

<sup>3</sup> E-mail: [albinas.palionis@ktu.lt](mailto:albinas.palionis@ktu.lt), +370 37 323894

<sup>4</sup> E-mail: [tadas.tolocka@ktu.lt](mailto:tadas.tolocka@ktu.lt), +370 37 323199

(Received 06 June 2007, accepted 18 June 2007)

**Abstract.** A study of novel tactile device transient processes that occurs during the information transmission has been described. Mathematical model has been presented and investigation of pin drive dynamics were performed. Results of investigations allowed us to evaluate the influence of drive parameters and operating regimes on the pin motion, and may be used in engineering practice for tactile device development.

**Keywords:** tactile device, transient motion, dynamics

### Introduction

The great variety of tactile systems in use [1]-[4] testifies that the disadvantages, such as system complexity, great cost, low reliability and functional possibilities are not overcome yet and the search of more promising solution remains the problem of today.

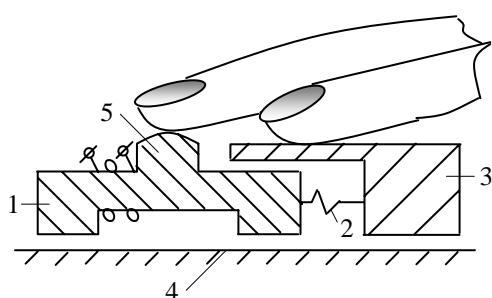

**Fig.1.** Schematics of the tactile device pin drive

The method, where information transmitting pin stimulates operator fingertip skin moving tangentially to it and the patented tactile device were proposed [5]. The scheme of its pin drive (some of them can be used) is shown in the Figure 1. Electromagnet 1 with wrapped winding is held by spring 2 in the mouse 3 which must be placed on the metallic surface 4. A pin 5 on the electromagnet is protruding from the housing. Operating principle of the proposed tactile device is as follows. When

the cursor is in the information area (black lines, letters) the control block sends signals and electromagnet of the drive is magnetized to the metallic surface. The pin slides along the fingertip and produces the strains in the skin at the contact area and thus transmits the information.

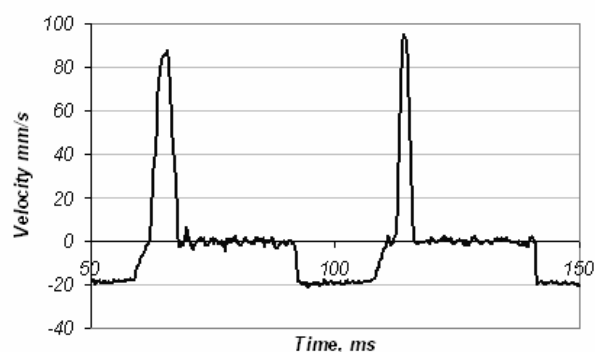

**Fig. 2.** Experimentally measured tactile device pin velocity

The interaction between finger skin and pin is there the key process because during it the information is transmitted to user.

The experiments have shown that the tactile device is functioning properly when the surface on which it is laid is clean and dry and the directions of the drive and movement of the device are kept parallel enough. In that case law of motion of the pin was measured (Figure 2).

During the investigation a significant parameters of the transitional process were framed – the time of the

transitional period and the maximum displacement of the transitional process. The relationship of transitional process parameters and dynamic parameters of the pin drive and working regime (surface friction, damping, rigidity, system load, speed of the mouse, initial deflection of pin,) was settled as a problem for the following investigation.

### Mathematical analysis

The mathematical model of the drive of tactile device was created taking into consideration that the pin is loaded by finger, and thus affected by friction forces, which occur in the contact of pin and finger and supporting surface. The drive dynamics is described by equation:

$$m\ddot{x} + b\dot{x} + kx = F_1 \text{sign}(\dot{x} - v_p) + F_2 \text{sign}\dot{x}. \quad (1)$$

where  $x$  is the pin deflection from equilibrium position,  $m$  is the mass of the electromagnet and pin;  $b$  and  $k$  are damping and stiffness of the drive system;  $F_1$  and  $F_2$  are the friction forces;  $v_p$  is the velocity of tactile system mouse motion and  $v_p$  is the mouse velocity.

The simpler case when the pin is not sliding along the finger (assuming  $F_1 = 0$ ) was under analytical investigation. Equation (1) here becomes

$$\ddot{x} + \omega_0^2 \cdot \frac{b}{k} \cdot \dot{x} + \omega_0^2 \cdot x = \omega_0^2 \cdot x_d; \quad (2)$$

where  $\omega_0^2 = \frac{k}{m}$  and  $x_d = \frac{F_2}{k}$ .

The natural frequency of the damped oscillations of the system is

$$\omega = \sqrt{\omega_0^2 - \alpha^2} = \omega_0 \cdot \sqrt{1 - \frac{\alpha^2}{\omega_0^2}} = \omega_0 \cdot \sqrt{1 - \frac{b^2}{4 \cdot m \cdot k}}; \quad (3)$$

where  $\alpha = -\frac{b}{2 \cdot m} = -\omega_0^2 \cdot \frac{b}{2 \cdot k}$ .

The general solution of the system (2) is

$$x(t) = \bar{x} + x^* = e^{\alpha t} (C_1 \cdot \cos \omega t + C_2 \cdot \sin \omega t) + x_d \quad (4)$$

with its derivative

$$\dot{x}(t) = e^{\alpha t} \left[ C_1 \cdot (\alpha \cdot \cos \omega t - \omega \cdot \sin \omega t) + C_2 \cdot (\alpha \cdot \sin \omega t + \omega \cdot \cos \omega t) \right]. \quad (5)$$

For the first stage of pin motion its initial displacement is  $x(t_0) = x_0$  and initial velocity -  $\dot{x}(t_0) = v_p$  at  $t_0 = 0$ .

Such initial conditions allow us to define constants  $C_1$  and  $C_2$ , and equation solution becomes

$$x(t) = e^{\alpha t} \cdot (X_{m,0} \cdot \cos(\omega t - \varphi_0)) + x_d; \quad (6)$$

where

$$X_{m,0} = \sqrt{(x_0 - x_d)^2 + \left( \frac{v_p - (x_0 - x_d) \cdot \alpha}{\omega} \right)^2} \quad (7)$$

and

$$\varphi_0 = \arctg \left( \frac{v_p}{\omega \cdot (x_0 - x_d)} - \frac{\alpha}{\omega} \right). \quad (8)$$

The pin velocity in respect of the mouse is

$$\dot{x}(t) = -e^{\alpha t} \cdot \omega_0 \cdot X_{m,0} \cdot \sin(\omega t - \varphi_0 + \varphi'_0), \quad (9)$$

where

$$\varphi'_0 = \arctg \left( -\frac{\alpha}{\omega} \right) = \arctg \left( \frac{b \cdot \omega_0}{\sqrt{4 \cdot k^2 - b^2}} \right), \quad (10)$$

and acceleration is

$$\ddot{x}(t) = -e^{\alpha t} \cdot \omega_0^2 \cdot X_{m,0} \cdot \cos(\omega t - \varphi_0 + 2 \cdot \varphi'_0). \quad (11)$$

The first pin displacement maximum  $i$  take place when pin velocity becomes equal to zero:

$$\dot{x}(t_a) = -e^{\alpha t_a} \cdot \omega_0 \cdot X_{m,0} \cdot \sin(\omega t_a - \varphi_0 + \varphi'_0) = 0. \quad (12)$$

We obtain

$$t_a = \frac{\varphi_0 - \varphi'_0}{\omega} \quad (13)$$

and corresponding maximum displacement

$$x_{m,a} = e^{\alpha \frac{\varphi_0 - \varphi'_0}{\omega}} \cdot X_{m,0} + x_d. \quad (14)$$

The second displacement extremity is its minimum obtained after time period  $t_c - t_a = \frac{\pi}{\omega}$ , and oscillation phase angle enlarges on  $\pi$  during it. Thus if the first extremity takes place at phase angle  $\omega \cdot t_a = \varphi_0 - \varphi'_0$ , the second one - at  $\omega \cdot t_c = \varphi_0 - \varphi'_0 + \pi$ . The corresponding time:

$$t_c = \frac{\pi + \varphi_0 - \varphi'_0}{\omega}. \quad (15)$$

The displacement minimum at it is equal to

$$x_{m,c} = -e^{\alpha \frac{\pi + \varphi_0 - \varphi'_0}{\omega}} \cdot X_{m,0} + x_d. \quad (16)$$

The largest difference in displacement would be

$$x_{m,a} - x_{m,c} = X_{m,0p} \cdot e^{\alpha \cdot \frac{\varphi_0 - \varphi'_0}{\omega}} \cdot \left( 1 + e^{\alpha \cdot \frac{\pi}{\omega}} \right). \quad (17)$$

The absolutely largest pin velocity value (negative,  $v_{m,b}$ ) will be obtained at the acceleration being equal to zero. This will take place at the phase angle and time values  $\omega t_b$  and  $t_b$ :

$$\omega \cdot t_b = \frac{\pi}{2} + \varphi_0 - 2 \cdot \varphi'_0, \quad (18)$$

$$t_b = \frac{\pi/2 + \varphi_0 - 2 \cdot \varphi'_0}{\omega}. \quad (19)$$

The pin velocity at this moment will be

$$v_{m,b} = -e^{\alpha \cdot \frac{\pi/2 + \varphi_0 - 2 \cdot \varphi'_0}{\omega}} \cdot \omega_0 \cdot X_{m,0}. \quad (20)$$

The pin will stop and dry friction force will change the direction at  $t_1$ , when pin velocity in respect of the mouse will reach value  $v_p$ :

$$\dot{x}(t_1) = -e^{\alpha t_1} \cdot \omega_0 \cdot X_{m,0} \cdot \sin(\omega \cdot t_1 - \varphi_0 + \varphi'_0) = v_p. \quad (21)$$

Due to the damping the oscillation amplitude is decreasing and the first friction force direction change will be at oscillation phase angle  $\omega t$  value which is larger, than  $\pi + 2\varphi_0$ . Following (17) we obtain

$$e^{\alpha t_1} \cdot \sin(\omega \cdot t_1 - \varphi_0 + \varphi'_0) = -\frac{v_p}{\omega_0 \cdot X_{m,0}}. \quad (22)$$

Becomes clear that the analytical solution is impossible because nor pin acceleration neither its displacement at  $t_1$  or at phase angle  $\omega t_1$  are known. It is available only in the limit case when the system damping or the mouse velocity  $v_p$  are large and the second largest value of the pin velocity at  $t_1$  do not exceed  $v_p$ , and thus dry friction force do not change its direction. At this case  $\dot{x}(t_1)$  will be equal to  $v_p$ , and acceleration  $\ddot{x}(t_1)$  will be equal to zero:

$$\dot{x}(t_1) = -\omega_0 \cdot X_{m,0} \cdot e^{\alpha t_1} \cdot \sin(\omega \cdot t_1 - \varphi_0 + 2\varphi'_0) = v_p; \quad (23)$$

$$\ddot{x}(t_1) = -\omega_0^2 \cdot X_{m,0} \cdot e^{\alpha t_1} \cdot \cos(\omega \cdot t_1 - \varphi_0 + 2\varphi'_0) = 0. \quad (24)$$

Because of  $\cos(\omega \cdot t_1 - \varphi_0 + 2\varphi'_0) = 0$  we obtain:

$$\omega \cdot t_1 = 0,5 \cdot \pi + \varphi_0 - 2 \cdot \varphi'_0 \quad (25)$$

and

$$t_1 = \frac{0,5 \cdot \pi + \varphi_0 - 2 \cdot \varphi'_0}{\omega}. \quad (26)$$

For the general case equation (1) is to be solved by computer methods.

### Simulation in Matlab Simulink environment

Model of tactile device pin interaction with finger was created in *MATLAB SIMULINK* environment and is shown in Figure 3, and can output displacement, velocity and acceleration of the pin during the information transmission process.

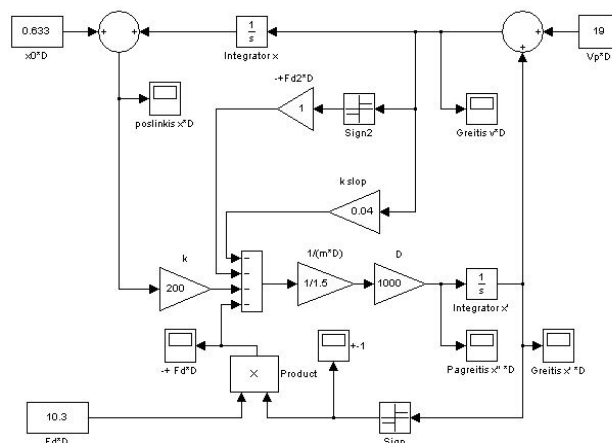

Fig. 3. Model of the tactile device drive, created in *MATLAB SIMULINK* environment

The law of damped pin motion and the impact of drive dynamical parameters on it were investigated. Some pin displacement curves at different damping factor values are shown in Figure 4.

It was defined what initial phase angle  $\varphi_0$  increases when the mouse velocity is increasing, and  $\varphi_0 = 0$ , when  $v_p = 0$ . Higher mouse velocity causes greater pin displacements. Friction forces are influencing all the parameters of vibrations. The greater displacement  $x_d$  due to friction displacements of the pin is enlarging initial phase angle and reducing the amplitude of vibrations. The initial pin displacement  $x_0$  influences very much the amplitude of vibrations and their damping.

The results of investigation allow us to evaluate quantitatively the influence of  $x_0$  and  $x_d$ , mouse velocity  $v_p$ , damping  $b$  and natural frequency  $\omega_0$  of the system on the law of pin motion in the transient process.

For the case when the pin is not sliding along the fingertip and damping is neglected, the steady state vibrations would be possible with amplitude  $x_m \leq v_p / \omega_0$ , which would be stabilized after  $0.5(x_0/x_d + 1)$  periods. If the friction between the fingertip and pin take place, the vibrations would be damped due to it after  $v_p / (4 \cdot x_d \cdot \omega_0)$  periods.

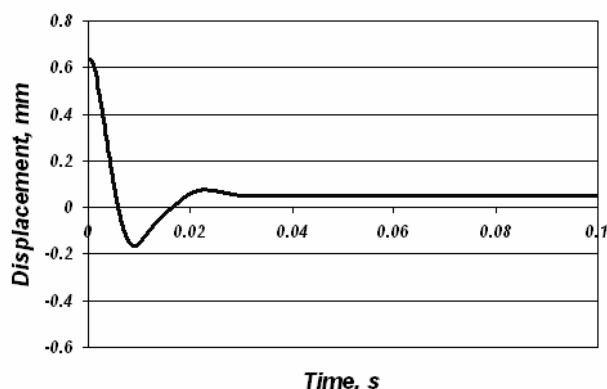
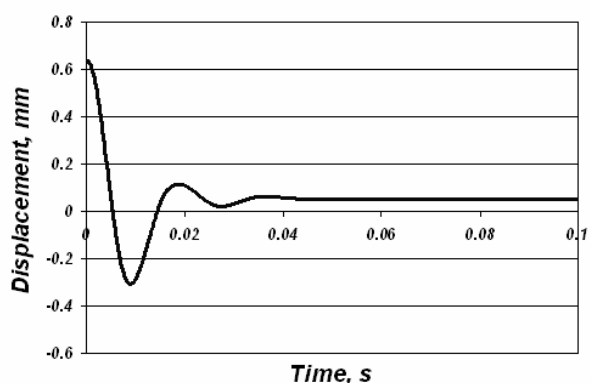
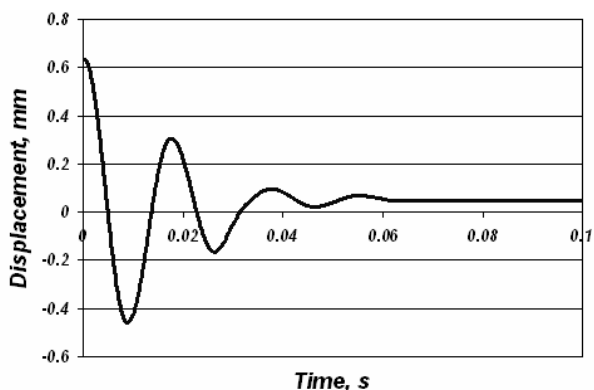

Fig. 4. Displacement of the pin when damping factor is 0.04 (a), 0.16 (b) and 0.32 (c)

## Conclusions

1. The dynamics of tactile device pin drive has been investigated in the transient process, which takes place when information signal disappears and the pin moves along the fingertip due to the spring elastic forces.
2. It was defined that the law of motion of the pin can not be obtained analytically in general case when damping is taken into account.
3. The model for the pin drive simulation in the *MATLAB SIMULINK* environment has been developed which allow us to investigate the influence of the dynamic

parameters of the drive and working regime parameters on the motion of the pin of tactile device.

## References

- [1] Akamatsu M., Mackenzie I.S., Hasbrouc T. *A Comparison of Tactile, Auditory and Visual Feedback in a Pointing Task Using a Mouse-type Device*, *Ergonomics*, 38, 316-827, 1995.
- [2] Hamilton, L. *An Open Letter to Federationists. The Braille Monitor*, 2002, v.45, No7, NFB, p.16-17.
- [3] Gouzman, R., Karasin, I., Rozenblum, D. *Mouse - like Input - Output Device with Display Screen and Method for its Use*, *WO 98/31005, PCT, WIPO*, 1998. –20 p.
- [4] Shimojo, M., Shinohara, M., Fukui, Y. *Human Shape Recognition Performance for 3D Tactile Display*, *IEEE Transaction on Systems, Man and Cybernetics, Part A, Vol.29, No 6, 637 – 644*, 1999.
- [5] Ažubalis, M., Bansevicius, R. *Computer mouse type Input –output device* The State Patent Bureau of the Republic of Lithuania, patent No.5159.