



1997

Corticosteroid Modulation of Hippocampal Neural Activity

Dayne Y. Okuhara
Loyola University Chicago

Follow this and additional works at: https://ecommons.luc.edu/luc_diss



Part of the [Pharmacology Commons](#)

Recommended Citation

Okuhara, Dayne Y., "Corticosteroid Modulation of Hippocampal Neural Activity" (1997). *Dissertations*. 3411.

https://ecommons.luc.edu/luc_diss/3411

This Dissertation is brought to you for free and open access by the Theses and Dissertations at Loyola eCommons. It has been accepted for inclusion in Dissertations by an authorized administrator of Loyola eCommons. For more information, please contact ecommons@luc.edu.



This work is licensed under a [Creative Commons Attribution-NonCommercial-No Derivative Works 3.0 License](#).
Copyright © 1997 Dayne Y. Okuhara

LOYOLA UNIVERSITY CHICAGO
CORTICOSTEROID MODULATION OF
HIPPOCAMPAL NEURAL ACTIVITY

A DISSERTATION SUBMITTED TO
THE FACULTY OF THE GRADUATE SCHOOL
IN CANDIDACY FOR THE DEGREE OF
DOCTOR OF PHILOSOPHY

DEPARTMENT OF PHARMACOLOGY AND EXPERIMENTAL THERAPEUTICS

BY

DAYNE Y. OKUHARA

CHICAGO, ILLINOIS

JANUARY, 1997

Copyright by Dayne Y. Okuhara, 1997
All rights reserved

**Dedicated to the my wife Susie and
the memory of Reid K. Shimabukuro**

ACKNOWLEDGMENTS

My sincerest thanks and gratitude to Dr. Sheryl G. Beck for her mentorship, patience, and guidance. I am indebted to Drs. Nancy Muma and Israel Hanin for their guidance throughout my graduate career and Dr. Nancy Muma for including me in her laboratory. I thank my committee members Drs. Rodrigo Andrade, Nancy Muma, Mary Manteuffel, and Russell Pieper for their time and contributions toward the development of this dissertation. My appreciation to the faculty, secretaries, and students of the Department of Pharmacology for their support and friendship. I am particularly appreciative to the Arthur J. Schmitt Foundation for their dissertation fellowship award.

I thank Dr. Robert Handa, George Hejna, Hana Kennedy, Geraldine Newfry, Steven Singer for their technical assistance. I am grateful to Matt Hejna, Christopher Chambers, Wendy Pouliot, and Dr. Anne Dean for just being my friends. Finally, my love and warmest thanks to my parents Stephen and Marjorie Okuhara, sister Lisa Okuhara, grandparents Haruo and Harue Okuhara, and Jane Inukai, my dog Indio Ramble, and my wife Susie for their unconditional support and love.

ABSTRACT

The neurons in hippocampal subfield CA3 contain corticosteroid mineralocorticoid (MR) and glucocorticoid (GR) receptors. The neurons in subfield CA3 have a critical role in hippocampal neural signal processing, yet very little is known about the effects of corticosteroids on neural activity in this subfield. Therefore, the actions of chronic corticosteroid treatment on neuron membrane electrical properties and the 5-HT_{1A} receptor system (receptor-G protein-potassium channel) were examined in rat hippocampal subfield CA3 pyramidal cells. The treatment groups used in these investigations were: adrenalectomy, MR activation with aldosterone or low levels of corticosterone, MR and GR activation with high levels of corticosterone, and sham.

Based on intracellular recording experiments, corticosteroid treatment altered the percentage of nonburst and burst firing neurons. There was a higher percentage of nonbursting cells from adrenalectomized animals compared to aldosterone and sham treated animals. The action potential duration was also longer in cells from adrenalectomized compared to cells from high corticosterone and aldosterone treated animals.

Corticosteroids altered the 5-HT concentration-response curve characteristics for the 5-HT_{1A} receptor. The EC₅₀ value was smaller in cells from adrenalectomized animals compared to the other treatment groups. The E_{max} value was smaller in cells

from animals treated with high corticosterone levels compared to sham and adrenalectomized animals. G protein function was also altered by corticosterone treatment. G protein activation elicited a smaller current in cells from high corticosterone treated animals compared to the other treatment groups and in cells from sham compared to adrenalectomized animals.

Western blot and immunohistochemistry techniques were used to determine the effects of corticosterone on G protein levels and distribution in the hippocampus. Treatment with high concentrations of corticosterone increased the levels of G_s , $G_{i1 \text{ and } 2}$ and G_o α -subunits when compared to sham. Adrenalectomy had no effect on G_s , $G_{i1 \text{ and } 2}$ or G_o α -subunits levels. No change in the intracellular location of G protein α -subunits was detected using immunohistochemistry.

This dissertation work has demonstrated that corticosteroids alter neuron electrical membrane properties and the 5-HT_{1A} receptor signal transduction system in hippocampal subfield CA3 neurons.

TABLE OF CONTENTS

ACKNOWLEDGEMENTS.	iii
ABSTRACT.	iv
LIST OF ILLUSTRATIONS.	x
LIST OF TABLES.	xii
LIST OF ABBREVIATIONS	xiii
Chapter	
I. INTRODUCTION.	1
II. REVIEW OF RELATED LITERATURE	8
Introduction	8
Corticosteroids Receptors	9
Structure and Mechanism of Action.	12
Pharmacology and Distribution	15
Regulation.	17
Regulation by Neuropeptides	18
Regulation by Neurotransmitters	19
Autoregulation.	21
Function.	24
Concluding Remarks.	26
Hypothalamic-Pituitary-Adrenal Axis.	26
Regulation of The HPA axis.	28

Chapter	Page
Neurotransmitter Systems Influencing HPA Axis Activity.	29
Feedback Regulation by Corticosteroids.	30
The Hippocampus and HPA Feedback Regulation.	33
Hippocampus Anatomy.	33
Corticosteroid Receptor Distribution and Regulation in the Hippocampus.	36
Hippocampus Influence on HPA Axis Activity.	37
Concluding Remarks.	39
Corticosteroid Modulation of Hippocampal Neuron Properties	39
Neuron Membrane Electrical Properties.	39
Hippocampus 5-HT _{1A} Signal Transduction System in Subfields CA1 and CA3.	42
5-HT _{1A} Receptor Structure and Distribution.	43
G protein Structure and Function.	45
Potassium Channel Linked to the 5-HT _{1A} receptor.	48
Corticosteroid Modulation of the 5-HT _{1A} Receptor System in Subfield CA1.	49
Concluding Remarks.	52
Clinical Importance.	52
Stress.	53

Chapter	Page
Senescence.	54
Depression.	55
Cushing Syndrome and Hypercorticotsteroid Secretion.	56
Concluding Remarks.	57
III. CORTICOSTEROIDS ALTER PYRAMIDAL CELL ELECTROPHYSIOLOGICAL CHARACTERISTICS IN HIPPOCAMPAL SUBFIELD CA3.	59
Abstract.	59
Introduction	60
Materials and Methods.	62
Results.	65
Discussion.	74
IV. CORTICOSTEROIDS ALTER 5-HT_{1A} SIGNAL TRANSDUCTION SYSTEM IN HIPPOCAMPAL SUBFIELD CA3 PYRAMIDAL CELLS.	82
Abstract.	82
Introduction	83
Materials and Methods.	85
Results.	90
Discussion.	96

Chapter	Page
V. DIFFERENTIAL IMMUNOHISTOCHEMICAL LABELING OF G _s , G _{i1} and 2 AND G _o α-SUBUNITS IN RAT FOREBRAIN.....	105
Abstract.....	105
Introduction.....	106
Materials and Methods.....	108
Results.....	112
Discussion.....	121
VI. CORTICOSTERONE ALTERS G PROTEIN α-SUBUNIT LEVELS IN THE RAT HIPPOCAMPUS.....	134
Abstract.....	134
Introduction.....	135
Materials and Methods.....	137
Results.....	142
Discussion.....	147
VII. DISCUSSION.....	155
APPENDIX	
Permission to Reprint Material.....	165
REFERENCES.....	166
VITA.....	220

LIST OF ILLUSTRATIONS

Figure	Page
1. Major corticosteroids in rat and humans.	10
2. Schematic representation of the MR and GR protein and its major domains.	14
3. Schematic model of the hypothalamic-pituitary-adrenal axis (HPA).	27
4. Schematic representation of the hippocampal trisynaptic circuit.	35
5. Diagrammatic representation of the 5-HT _{1A} receptor.	44
6. Cartoon illustration of the G protein cycle.	47
7. Membrane potential changes in nonbursting and burst firing cells.	68
8. Superimposed action potentials in a cell from an ADX and HCT animal.	73
9. Concentration-dependent response of subfield CA3 pyramidal cells to 5-HT perfusion.	93
10. The outward current elicited by the perfusion of 5-HT in the presence or absence of 5-HT ₄ and 5-HT ₇ receptor antagonists.	95
11. The outward current evoked by GTP γ S.	97
12. I-V plots of 5-HT mediated current from corticosteroid treated animals.	99

Figure	Page
13. Western blot of G proteins in the rat hippocampus.	112
14. Photographs of G protein labeling in the cortex.	115
15. Photographs of G protein labeling in the hippocampus.	117
16. Photographs of G protein labeling in the striatum and habenula.	119
17. Photographs of G protein labeling in the thalamus, infundibular stem, and white matter fiber tracts.	120
18. Camera lucida of G protein labeling in the subcortex.	124
19. Western blots of G protein α -subunits prepared from hippocampal membrane fractions.	144
20. Coomassie blue stained gel of tissue samples used for Western Blots.	145
21. Changes in G protein α -subunit levels with different corticosterone treatments.	146
22. Immunohistochemical labeling of G protein α -subunits and cresyl violet staining of nissel bodies in the hippocampus.	148

LIST OF TABLES

Table	Page
1. Treatment groups.	64
2. Number of nonbursting and bursting cells recorded from the different corticosterone treatment groups.	69
3. The effects of corticosteroids on passive membrane electrophysiological properties.	69
4. The effect of corticosteroids on action potential and fAHP properties.	72
5. The effect of corticosteroids on sAHP and accommodation properties.	74
6. The effect of corticosteroids on the 5-HT concentration-response curve characteristics for the 5-HT _{1A} receptor.	93
7. G protein like immunoreactivity in medial rat brain sections.	122

LIST OF ABBREVIATIONS

ADX	adrenalectomized treatment group
ACSF	artificial cerebrospinal fluid
ACTH	adrenocorticotrophic hormone
ALD	aldosterone treatment group
ANOVA	analysis of variance
CNS	central nervous system
CRF	corticotropin releasing factor
CT	12.5 mg corticosterone treatment group
DLG	dorsal lateral geniculate nuclei
EPSP	excitatory post synaptic potentials
fAHP	fast afterhyperpolarization
GABA	γ -aminobutyric acid
GR	glucocorticoid receptor
GRE	glucocorticoid response elements
HCT	200-300 mg corticosterone treatment group
HPA	hypothalamus-pituitary-adrenal
IOD	integrated optical density

LP	lateral thalamic posterior nuclei
mg	milligram
μs	microseconds
ml	milliliter
MΩ	megaohms
MR	mineralocorticoid receptor
mRNA	messenger ribonucleic acid
ms	milliseconds
mV	millivolts
NA	noradrenaline
pA	picoamperes
PTX	pertussis toxin
PVN	paraventricular nucleus
sAHP	slow afterhyperpolarization
SEM	standard error of the mean
VLG	ventral lateral geniculate nuclei
VNAB	ventral noradrenergic ascending bundle
VPT	ventral posterior thalamic nuclei
5-HT	5-hydroxytryptamine or serotonin
6-OHDA	6-hydroxy-dopamine

CHAPTER I

INTRODUCTION

Corticosteroids are steroid hormones that maintain energy, ion, and endocrine homeostasis (de Kloet, 1991; Henkin, 1970; Munck *et al.*, 1984). There are two classes of corticosteroids: glucocorticoids and mineralocorticoids. Glucocorticoids regulate glucose metabolism while mineralocorticoids maintain ion homeostasis (reviewed by Dallman *et al.*, 1987, 1994; de Kloet, 1991; Tempel and Leibowitz, 1994).

Corticosterone is the principal glucocorticoid in rats while in man the principal glucocorticoid is cortisol. Aldosterone is the principal mineralocorticoid in both man and rats.

Corticosteroids regulate gene expression through the interaction with two receptor subtypes: mineralocorticoid receptor (MR) and glucocorticoid receptor (GR). MR has a high affinity for corticosterone, $K_D = 0.5 - 0.7$ nM, and aldosterone (Krozowski and Funder, 1983; Reul and de Kloet, 1985). GR has a lower affinity for corticosterone, $K_D = 2.5 - 5$ nM and aldosterone (Krozowski and Funder, 1983; Reul and de Kloet, 1985).

The synthesis and release of corticosteroids are regulated by the hypothalamic-pituitary-adrenal axis (HPA) (reviewed by Feldman and Weidenfeld, 1995). In response to various stimuli, paraventricular (PVN) neurons in the hypothalamus release

corticotropin releasing factor (CRF) into the portal circulation. CRF then stimulates the synthesis and release of adrenocorticotrophic hormone (ACTH) from the corticotropes in the anterior pituitary. ACTH enters the circulatory system and drives the synthesis and release of corticosteroids from the adrenal cortex.

There are two physiological processes that drive HPA axis activity: circadian rhythm and stress (reviewed by Dallman *et al.*, 1987, 1994). Corticosteroid plasma levels are lower ($< 10 \mu\text{g/dl}$) during hours when the animals is resting (i.e., during day light for rats) and higher ($> 15 \mu\text{g/dl}$) during hours when the animal is active (i.e., at night for rats) or stressed. The relative occupation of MR and GR changes with physiological fluctuations in the plasma corticosteroid levels. MR is 70-80% occupied at basal physiological corticosterone plasma levels (Reul and de Kloet, 1985; Reul *et al.*, 1987). GR occupancy changes from 15% at basal to 90% at peak and stress circulating corticosterone levels (Reul and de Kloet, 1985; Reul *et al.*, 1987a,b). HPA axis activity is regulated by higher cortical and brainstem inputs that converge at the hypothalamus and influence CRF secretion (reviewed by Feldman and Weidenfeld, 1995). However, corticosteroids also modulate HPA axis activity through feedback inhibition via the activation of MR and GR in the PVN, pituitary, and hippocampus (reviewed by Dallman *et al.*, 1987, 1994).

The relationship between the serotonin (5-HT) system and HPA axis has been examined in different biological states including depression (reviewed by Lesch and

Lerer, 1991), development (reviewed by Meaney *et al.*, 1994), and in animal strains characterized by altered HPA activity (Burnet *et al.*, 1994). For example, it was demonstrated that postnatal handling of rat pups reduces the HPA response to stress (reviewed by Meaney *et al.*, 1994). Meaney *et al.*, (1994) hypothesize that the decreased HPA response to stress is due to a more sensitive corticosteroid feedback inhibition. Furthermore, the increased feedback inhibition may be related to an increase in 5-HT turnover (Smythe *et al.*, 1994) and GR receptor expression in the hippocampus (Meaney and Aitken, 1985; O'Donnell *et al.*, 1994).

The hippocampus contains the highest concentration of corticosteroid receptors in the central nervous system (McEwen *et al.*, 1968; Coirini *et al.*, 1983, 1985; Reul and de Kloet 1985, 1986; Magarinos *et al.*, 1989). Corticosteroid receptors have at least two physiological roles in the hippocampus: influencing HPA axis activity via a negative feedback mechanism and modulating hippocampus related behaviors (reviewed by Jacobson and Sapolsky, 1991; de Kloet *et al.*, 1993). It is still not clear how corticosteroids influence neural signal processing in the hippocampus. Several important questions remained answered. For example, exactly where in the hippocampus are corticosteroids exerting their modulatory effect?

The hippocampus is divided into three regions; hippocampus proper, dentate gyrus, and the subiculum (reviewed by Knowles, 1992; Bernard and Wheal, 1994). The hippocampus proper is further divided into four subfields, CA1-4. The cells in the

different hippocampal regions and subfields have unique roles in hippocampal signal processing based on their different positions within the trisynaptic circuit. The cells in subfield CA3 receive their inputs from the dentate gyrus, perforant pathway axons, neighboring CA3 cells. The cells in subfield CA1 receive their inputs almost entirely from subfield CA3 (reviewed by Knowles, 1992; Bernard and Wheal, 1994).

Corticosteroid modulate pyramidal cell membrane properties and the response elicited by the activation of 5-HT_{1A} receptors on subfield CA1 cells (Joëls and de Kloet, 1994; Beck *et al.*, 1994, 1996). Activation of the 5-HT_{1A} receptor in the hippocampus hyperpolarizes the cell membrane potential (Andrade and Nicoll, 1987; Colino and Haliwell, 1987; Beck and Choi, 1991; Beck *et al.*, 1992). The 5-HT_{1A} receptor signal transduction system mediating the hyperpolarization is composed of a receptor, heterotrimeric guanine nucleotide binding protein (G protein), and potassium channel (Andrade *et al.*, 1986; Okuhara and Beck, 1994).

The actions of corticosteroids on pyramidal cell membrane electrical properties and the 5-HT_{1A} receptor signal transduction system in subfield CA3 are not known, yet this information is crucial towards elucidating the mechanism by which corticosteroids modulate signal processing in the hippocampus. In addition to their differences in neuronal organization and synaptic inputs, the pyramidal neurons in subfields CA1 and CA3 have different cell membrane electrical properties (Nunez *et al.*, 1990; Beck *et al.*, 1992; Spruston and Johnston, 1992), 5-HT_{1A} receptor concentration-response curve

characteristics (Beck *et al.*, 1992, Okuhara and Beck, 1994), and when these regions are stimulated their effects on HPA axis activity are not the same (Kawakami *et al.*, 1968; Dunn and Orr, 1984; Daniels *et al.*, 1994). Therefore information on the actions of corticosteroids on pyramidal cell membrane electrical properties and the 5-HT_{1A} receptor signal transduction system in subfield CA3 will contribute to a basic understanding of how corticosteroids alter cell excitability, responses elicited by the activation of G protein-linked neurotransmitter receptors, and help to elucidate the role of corticosteroid receptors in information processing in the hippocampus.

The goal of this dissertation is 1) to determine the effects of chronic corticosteroid treatment on neuron membrane electrical properties and/or 2) the 5-HT_{1A} receptor-mediated response on pyramidal cells in hippocampal subfield CA3 and 3) determine which component(s) of the 5-HT_{1A} receptor signal transduction system is modulated by corticosteroids. The underlying hypothesis of this dissertation is that chronic corticosteroid treatment modulates pyramidal cell excitability and/or the 5-HT_{1A} receptor signal transduction system in hippocampal subfield CA3. This hypothesis was tested with experiments designed to address four specific aims.

Four treatment groups were used in this dissertation. Adult rats were surgically treated to achieve 1) no corticosteroid receptor occupancy, 2) MR occupancy only, 3) occupancy of both MR and GR, and 4) sham. All treatments were for 13 -15 days.

Specific Aim 1: Determine if corticosteroids alter pyramidal cell electrophysiological properties in hippocampal subfield CA3.

Intracellular recording techniques were used in hippocampal slices maintained *in vivo* to measure passive and active membrane electrical characteristics.

Specific Aim 2: Determine if corticosteroids alter the 5-HT concentration-response curve characteristics for the 5-HT_{1A} receptor in hippocampal CA3 pyramidal cells.

Intracellular recording techniques were used in hippocampal slices maintained *in vivo* to examine the 5-HT concentration-response curve characteristic for the 5-HT_{1A} receptor.

Specific Aim 3: Determine the effects of corticosteroids on the 5-HT_{1A} signal transduction components: (1) The current evoked by direct activation of G proteins and (2) the current-voltage relationship for the potassium current linked to the 5-HT_{1A} receptor.

Corticosteroids may modulate one or more of the 5-HT_{1A} signal transduction components (i.e., receptor, G protein, or ion channel). Therefore, intracellular recording techniques were used in hippocampal slices maintained *in vivo* to examine the action of corticosteroids on 1) the outward current evoked by the activation of G proteins with GTP γ S, and 2) the current-voltage (I-V) relationship of the potassium channels linked to the 5-HT_{1A} receptor.

Specific Aim 4: Determine the effects of corticosteroids on the 5-HT_{1A} signal transduction components: G protein expression in the hippocampus.

Western blot and immunohistochemistry techniques were used to determine the effects of corticosteroids on G protein levels and distribution in the hippocampus.

CHAPTER II

REVIEW OF RELATED LITERATURE

Introduction

Adrenal corticosteroids are divided into two classes, glucocorticoids and mineralocorticoids (**Figure 1**). Corticosteroids maintain homeostasis, influence mood, sensory detection, and perception (reviewed by Henkin 1970; Munck *et al.*, 1984; de Kloet, 1991). T. Addison first published his results on the death of patients with adrenal destruction in 1855. Later, H. Cushing (1932) and Harris (1948) established that the hypothalamus-pituitary-adrenal (HPA) axis regulates corticosteroid synthesis and secretion. The actions of corticosteroids are mediated mainly through two receptor subtypes: glucocorticoid and mineralocorticoid receptors.

The first section of this literature review covers the description, pharmacology, function, and regulation of corticosteroid receptors in mammals. Section two describes the components, function, and regulation of the HPA axis. The regulation of HPA axis activity is complex, involving several feedback loops and extrahypothalamic pathways. One system which has an important modulatory influence on HPA axis activity is the limbic system, in particular, hippocampal inputs into the HPA axis. Section three reviews the role of the hippocampus in regulating HPA activity. In addition to their

physiological effects in the periphery, corticosteroids also influence neural activity.

Section four reviews the available information on corticosteroid-induced changes in neuron electrophysiological properties and the responses elicited by the activation of the 5-HT_{1A} receptor in the hippocampus. The final section summarizes the known and proposed roles of corticosteroids in pathological conditions. The scientific contribution of this dissertation is also addressed in this section.

Corticosteroids Receptors

Glucocorticoids have a wide variety of effects on many cell functions (reviewed by Kraus-Friedmann, 1984; Pilgis and Granner, 1992). Glucocorticoids stimulate gluconeogenesis, increase amino acid uptake by the liver and kidney, increase amino acid release through muscle catabolism, and stimulate lipolysis. The primary role of glucocorticoids is to provide glucose for energy demanding tissues such as the brain and heart, especially under conditions of stress. Glucocorticoids also have immunosuppressive, anti-inflammatory, and anti-asthmatic properties (Falaschi *et al.*, 1994; Derijk and Sternberg, 1994; Barnes, 1996; Laitinen and Laitinen, 1996; Schwiebert *et al.*, 1996) while supraphysiological levels decrease muscle mass, leading to muscle weakness (Caldwell *et al.*, 1978; Goldberg *et al.*, 1980; Florini, 1987; Smith *et al.*, 1990).

Glucocorticoids exert their effects directly by regulating the synthesis of key enzymes and proteins, or permissively, by influencing the sensitivity of cells to other hormones or extracellular signals. For example, glucocorticoids elevate blood glucose

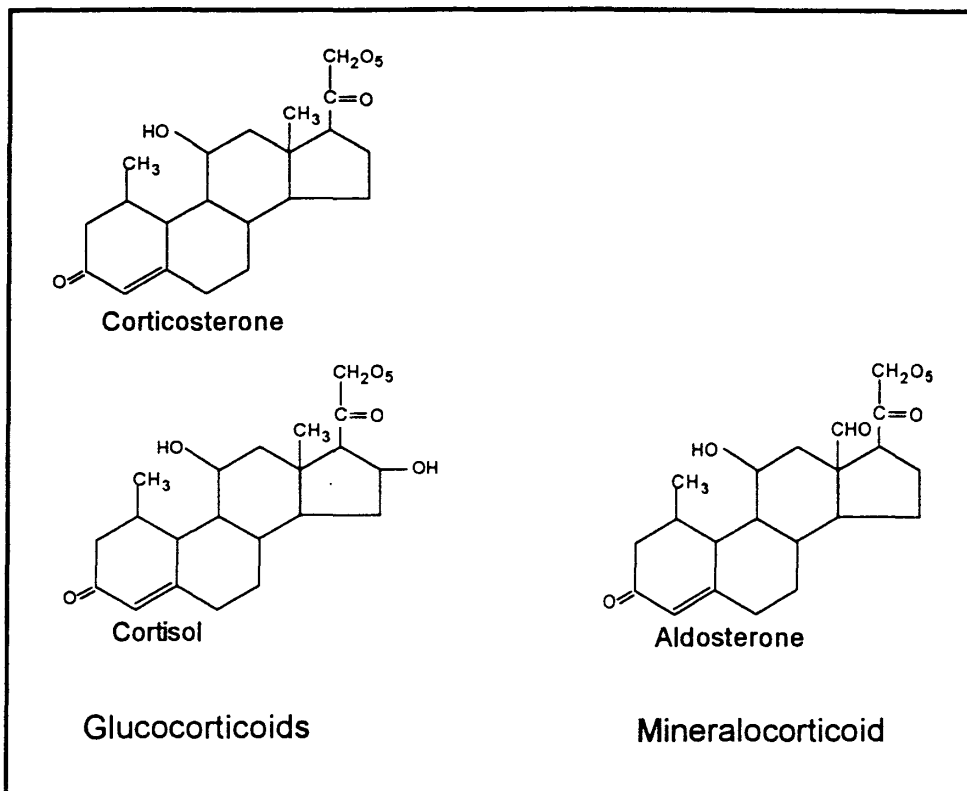

Figure 1. Major corticosteroids in rat and humans. The two classes of corticosteroids are glucocorticoids and mineralocorticoids. Corticosterone is the major glucocorticoid in rat, while cortisol is the major glucocorticoid in humans.

levels directly by increasing the synthesis of hepatic phosphoenolpyruvate carboxykinase (Beale *et al.*, 1982; Lamers *et al.*, 1982) and branched-chain α -ketoacid dehydrogenase (Block *et al.*, 1970; Block and Buse, 1990), rate limiting enzymes for gluconeogenesis and skeletal muscle catabolism respectively. Glucocorticoids act permissively by increasing the sensitivity of adipose cells to catecholamines (reviewed by Munck and Guyre, 1986; Malbon *et al.*, 1988).

Mineralocorticoids maintain fluid and electrolyte homeostasis. Aldosterone primarily acts at the kidney to increase Na^+ reabsorption and excretion of K^+ and H^+ (O'Neil, 1990; Funder, 1993; Horisberger and Rossier, 1995; Eaton *et al.*, 1995). Aldosterone affects electrolyte transport at the distal tubules and collecting ducts by increasing the synthesis of Na^+ (Chu and Edelman, 1972; Rousseau and Crabbe, 1972; Lahav *et al.*, 1973; Rossier *et al.*, 1978; Garty, 1986) and K^+ channels (Koppen *et al.*, 1983; Stokes, 1985; Sansom and O'Neil, 1986; Sansom *et al.*, 1989; Illek *et al.*, 1990; Schafer *et al.*, 1990) and the Na^+, K^+ -ATPase pump (Geering *et al.*, 1982; Ewart and Klip, 1990; Verry, 1990; Shahedi *et al.*, 1993).

Glucocorticoids regulate gene expression through the interaction with at least two receptor subtypes; type I or MR and the type II or GR. Both types of corticosteroid receptors are intracellular receptors which bind to DNA and influence gene transcription (reviewed by Dahlman-Wright *et al.*, 1992). The two receptors are distinguished pharmacologically by their relative affinity for corticosterone and other selective ligands.

Structure and Mechanism of Action

Corticosteroid receptors are intracellular receptors that regulate the expression of specific genes. Both MR and GR have been cloned and their sequences are highly homologous (Arriza *et al.*, 1987; Patel *et al.*, 1989). GR has been the focus for the majority of the biochemical and functional studies, therefore, the following section reviews the information available for GR. However, since both MR and GR belong to the same steroid receptor family, they have many functional similarities (Pearce, 1994).

The unoccupied receptor usually resides in the cytoplasm, translocating into the nucleus after binding to the steroid (Govindan, 1980; Pampichail *et al.*, 1980; Antakly *et al.*, 1984; Fuxe *et al.*, 1985; Wikstrom, *et al.*, 1987; Picard, 1987; LaFond *et al.*, 1988; Gasc *et al.*, 1989). The unoccupied receptor is maintained in an inactive state by a multi-protein complex. This complex contains GR (Okret, 1985) associated with heat shock proteins hsp56 (Sanchez, 1990), hsp70 (Sanchez, 1990; Sanchez *et al.*, 1990), and hsp90 (Catelli *et al.*, 1985; Sanchez *et al.*, 1985; Sanchez *et al.*, 1990). Steroid binding dissociates hsp90 from GR (Mendel *et al.*, 1986; Sanchez *et al.*, 1987a), forming an 'activated' receptor with increased affinity for DNA (Sanchez *et al.*, 1987b; Howard and Distelhorst, 1988a,b). Activated GRs dimerize and bind to specific DNA sequences (Tsai *et al.*, 1988; Wrange *et al.*, 1989; Chalepakis *et al.*, 1990), known as glucocorticoid response elements (GRE) and influence gene transcription (Yamamoto, 1985).

A great deal of information is known about the structure of MR and GR. Purified GR is 90-100 kDa when resolved by SDS-gel electrophoresis (Govindan and Manz, 1980; Bernard and Joh, 1984; Govindan and Gronemeyer, 1984; Grandics *et al.*, 1984; Idziorek *et al.*, 1985; Lustenberger *et al.*, 1985; Webb *et al.*, 1985). Based on nucleotide sequences of MR and GR, the two receptors are comprised of approximately 780 amino acids and are highly conserved across different species (Hollenberg *et al.*, 1985; Danielsen *et al.*, 1986; Miesfeld *et al.*, 1986; Arriza *et al.*, 1987; Patel *et al.*, 1989). Corticosteroid hormone receptors are single chain polypeptides containing three distinct functional domains: ligand binding, DNA binding, and N-terminal domains (**Figure 2**) (reviewed by Gustafsson *et al.*, 1987; Dahlman-Wright *et al.*, 1992; Wright *et al.*, 1993). The different domains were first identified through limited proteolysis of the purified protein (Carlstedt-Duke *et al.*, 1977, 1982, 1987; Wrangé and Gustafsson, 1978; Westphal *et al.*, 1984; Wrangé *et al.*, 1984). Point mutation analysis of the cDNA clones allowed researchers to identify the amino acid residues critical for the proper function of each domain (reviewed by Dahlman-Wright *et al.*, 1992; Gehring, 1993).

The ligand binding domain is in the carboxy-terminal end of the peptide, covering approximately 250 amino acids (Carlstedt-Duke *et al.*, 1987; Hollenberg *et al.*, 1987; Rusconi and Yamamoto, 1987). The hormone binding domain in MR and GR share a 57 % homology in humans (Arriza *et al.*, 1987) and 59 % in rats (Patel *et al.*, 1989). Removal of this domain produces a constitutively active receptor (Danielson *et al.*, 1987;

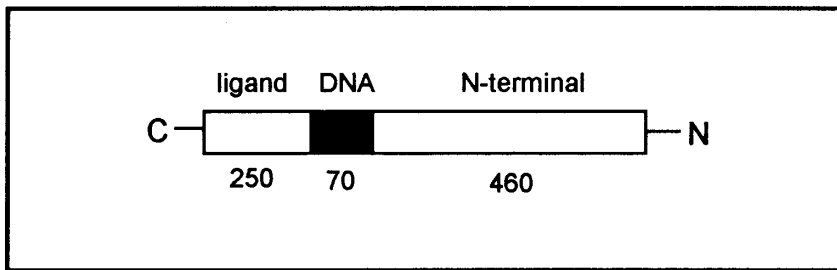

Figure 2. Schematic representation of the MR and GR protein and its major domains. The domains are labeled at the top of the diagram while the approximate amino acid size of the domain is located at the bottom.

Godowski *et al.*, 1987; Hollenberg *et al.*, 1987; Meisfeld *et al.*, 1987). Biochemical analysis of this domain reveals that it folds into a complex secondary and tertiary structure, important for proper steroid binding (reviewed by Dahlman-Wright, *et al.*, 1992; Gehring 1993) and translocation into the nucleus (Picard and Yamamoto, 1987).

The DNA binding domain is in the middle of the polypeptide. The MR and GR DNA binding domains are 94 % homologous in humans (Arriza *et al.*, 1987) and 76 % in rats (Patel *et al.*, 1989). This domain contains 70 amino acids which are highly conserved with other steroid receptors (Giguere *et al.*, 1986; Carlstedt-Duke *et al.*, 1987; Danielson *et al.*, 1987; Hollenberg *et al.*, 1987; Meisfeld *et al.*, 1987; Rusconi and Yamamoto, 1987; Evans, 1988; Hard *et al.*, 1990). The prominent feature of this domain is the coordination of cysteine residues and zinc ions to form the DNA binding structure (Freedman *et al.*, 1988; Severne *et al.*, 1988; Hard *et al.*, 1990).

The N-terminal domain sequence is highly variable with other intracellular steroid receptors (reviewed by Evans, 1988; Beato, 1989). The N-terminal domain in MR and GR share only a 15 % homology in humans (Arriza *et al.*, 1987) and 40 % in rats (Patel *et al.*, 1989). Very little is known about the function of this domain and how the different amino acids contribute to the activity of the receptors. This domain may be important for the transactivation of GR with other transcription factors (Hollenberg *et al.*, 1987; Danielson *et al.*, 1987; Gehring and Segnitz, 1988; Hollenberg and Evans, 1988).

Pharmacology and Distribution

Several experimental techniques, including *in situ* hybridization, autoradiography, and immunohistochemistry were used to map the distribution of MR and GR in the central nervous system (CNS). Convincing pharmacological evidence for the existence of two corticosteroid receptor subtypes came with the development of drugs that were selective for MR and GR and allowed researchers to distinguish the two receptors and their differential distribution in the CNS.

[³H]corticosterone binding macromolecules in the brain were initially identified in the early 1970's (McEwen and Plapinger, 1970; Grosser *et al.*, 1971; Gerlach and McEwen, 1972; McEwen *et al.*, 1972; Grosser *et al.*, 1973). These early investigations demonstrated that corticosterone binding was not uniformly distributed. Corticosterone binding was much higher in limbic areas, especially the hippocampus, compared to other regions of the brain (McEwen *et al.*, 1969, 1970, 1972; McEwen and Plapinger, 1970;

Grosser *et al.*, 1971; Stevens *et al.*, 1971; Gerlach and McEwen, 1972; Warembourg, 1975; Stumpf and Sar, 1979; Sapolsky *et al.*, 1983b). However, binding experiments with the native mineralocorticoid aldosterone (Anderson and Fanestil, 1976; Moguilevski and Raynaud, 1980; De Nicola *et al.*, 1981; Veldhuis *et al.*, 1982; Beaumont and Fanestil, 1983; Krozowski and Funder, 1983; Wrange and Yu, 1983) and synthetic glucocorticoid dexamethasone (de Kloet ER *et al.*, 1975; Rees *et al.*, 1975; Rhees *et al.*, 1975; Warembourg, 1975) produced two different corticosteroid receptor distributions. The accumulated data lead investigators to suggest that two corticosteroid receptor populations existed in the brain.

The development of selective MR antagonist RU 26752 and RU 26813 (Coirini *et al.*, 1985), GR agonist RU 26988 and RU 28362 (Moguilevsky and Raynaud, 1980; Coirini *et al.*, 1985), and GR antagonist RU 38486 (Gagne *et al.*, 1985) allowed researchers to pharmacologically characterize and map the distribution of MR and GR in the CNS. The two receptor subtypes are distinguished by their relative affinities for the endogenous corticosteroids corticosterone and aldosterone. MR has a high affinity for corticosterone ($K_D = 0.5$ nM) and aldosterone. In contrast, GR has a low affinity for corticosterone ($K_D = 2 - 5$ nM) and aldosterone (Veldhuis *et al.*, 1982; Beaumont and Fanestil, 1983; Krozowski and Funder, 1983; Coirini *et al.*, 1985; Reul and de Kloet, 1985; Sheppard and Funder, 1987). Dexamethasone is a synthetic glucocorticoid with a

higher affinity for GR (Veldhuis *et al.*, 1982; Krozowski and Funder, 1983; Coirini *et al.*, 1985).

The hippocampus contains the highest concentration of MR and GR in the CNS. MR binding is almost exclusively located in the hippocampus while GR binding is also found in other CNS areas including the cortex, ventromedial thalamic nuclei, arcuate, and lateral septum (Coirini *et al.*, 1983, 1985; Reul and de Kloet 1985, 1986; Magarinos *et al.*, 1989).

Regulation

Corticosteroid receptor levels in the brain are dynamically regulated by neuropeptides, neurotransmitters, and corticosteroids (via an autoregulatory mechanism) (reviewed by de Kloet *et al.*, 1986a; Herman, 1993; Budziszewska and Larson, 1994). The regulation of MR and GR depends upon the brain area (i.e., hippocampus versus hypothalamus) and which physiological factor is evoking the change in MR and GR binding (i.e., neurotransmitters versus autoregulation). Furthermore, the regulation of corticosteroid receptors by neuropeptides, neurotransmitters, or corticosteroids may represent three independent physiological mechanisms underlying control of HPA axis activity (see Hypothalamic-Pituitary-Adrenal Axis). A large number of investigations have focused on the regulation of corticosteroid receptors in the hippocampus, where corticosteroid receptors have an important role in HPA axis feedback and behavior (Jacobson and Sapolsky, 1991).

Regulation by Neuropeptides

HPA axis activity is regulated by two principal neuropeptides, CRF and ACTH (see Hypothalamic-Pituitary-Adrenal Axis). CRF and the ACTH analog ORG 2766 both modulate corticosteroid receptor levels. CRF decreases GR binding and mRNA levels in the anterior pituitary and in AT20 anterior pituitary corticotrope cell culture (Sheppard *et al.*, 1990, 1991), but increases the GR mRNA levels in the hippocampus (Sheppard *et al.*, 1990). ORG 2766 is an ACTH analog that has no effect on corticosteroid secretion from the adrenal gland (Greven and de Weid, 1973; de Weid and Jolles, 1982). However, ORG 2766 administration increases corticosteroid receptor binding in the hippocampus (Rigter *et al.*, 1984; Reul *et al.*, 1988). Selective MR and GR ligands were used to demonstrate that ORG 2766 selectively increases MR binding in the hippocampus (Reul *et al.*, 1988). The effects of ORG 2766 in the pituitary and hypothalamus are not known.

Another neuropeptide which is also released from the hypothalamus is vasopressin (Kiss *et al.*, 1984; Plotsky *et al.*, 1985; Davis *et al.*, 1986; Holmes *et al.*, 1986; Fink *et al.*, 1988; Canny *et al.*, 1989). Vasopressin is released by hypothalamic PVN neurons in response to stress (Plotsky *et al.*, 1985; Canny *et al.*, 1989) and influences water-intake, learning and memory (de Wied, 1971; Bohus *et al.*, 1975; de Weid *et al.*, 1975; de Kloet and de Wied, 1980). Vasopressin increases corticosteroid receptor binding capacity in

the hippocampus and GR receptors in the anterior pituitary (Veldhuis and de Kloet, 1982).

The mechanisms underlying the neuropeptide-induced changes in corticosteroid receptor binding are largely unknown. However, the neuropeptide actions are independent of corticosteroid hormones (Veldhuis and de Kloet, 1982; Reul *et al.*, 1988; Shepherd *et al.*, 1990). While the normal physiological roles of CRF-, ACTH-, and vasopressin-induced changes in corticosteroid receptor levels are not known, these peptides generally display trophic effects in certain diseased and aged brains, restoring deficient corticosteroid receptors and HPA responsiveness (de Kloet *et al.*, 1986a; Reul *et al.*, 1988).

Regulation by Neurotransmitters

One brain area in which neurotransmitters appear to have an important role in regulating corticosteroid receptor expression is the hippocampus (Siegel *et al.*, 1983; Weidenfeld *et al.*, 1983). Modulation of corticosteroid receptors in the hippocampus by neurotransmitters may be important in affecting mood, behavior, and neuroendocrine responses (Azmitia *et al.*, 1984; Budziszewska and Larson, 1994).

The 5-HT neurotransmitter system regulates corticosteroid receptor binding. Lesioning 5-HT neurons in the raphe nucleus or depleting neurons of 5-HT decreases corticosteroid receptor binding in the mediobasal hypothalamus and hippocampus (Siegel *et al.*, 1983; Weidenfeld *et al.*, 1983; Weidenfeld and Feldman, 1991a; Novotney and

Lowy, 1995). Lesioning 5-HT neurons in the raphe nucleus also decreases GR and MR mRNA levels in the hippocampus (Seckl *et al.*, 1990; Seckl and Fink, 1991). In cultured hippocampal neurons, 5-HT increases GR binding capacity without altering the binding capacity of MR (Mitchell *et al.*, 1990). The 5-HT receptor mediating the upregulation of GR binding capacity in cultured hippocampal neurons is the 5-HT₂ receptor (Mitchell *et al.*, 1992). In contrast to cultured neurons, 5-HT_{1A} agonists increase MR binding capacity in the hippocampus *in vivo* (Budziszewska *et al.*, 1995).

Other neurotransmitter systems which also modulate corticosteroid receptor binding capacity or mRNA levels in the brain are the noradrenergic (Maccari *et al.*, 1990; 1992a,b; Yau and Seckl, 1992; Kabbaj *et al.*, 1995), cholinergic (Nyakas *et al.*, 1979; Yau *et al.*, 1992), and dopaminergic systems (Casolini *et al.*, 1993). Interestingly, the different neurotransmitter systems have different effects on corticosteroid receptor binding capacity and mRNA levels. Noradrenaline (NA) alters corticosteroid receptor binding capacity and mRNA levels (Maccari *et al.*, 1992a,b; Yau and Seckl, 1992; Kabbaj *et al.*, 1995). Cholinergic neurotransmitters do not modulate MR and GR binding capacity but alter their mRNA levels (Nyakas *et al.*, 1979; Yau *et al.*, 1992). Dopamine does not alter MR and GR binding capacity but alters the affinity of GR for corticosterone (Casolini *et al.*, 1993).

The mechanisms underlying the neurotransmitter-induced changes in corticosteroid receptor binding capacity are not known. Changes in corticosteroid receptor mRNA

levels do not always parallel the changes in receptor binding capacity. Furthermore, in certain cases (i.e., 5-HT₂ modulation of GR) (Mitchell *et al.*, 1992), changes in corticosteroid receptor binding capacity are dependent on the production of second-messengers by the activated neurotransmitter receptor. Indeed, protein kinase A dependent mechanisms (Kendal and Robinson, 1990) have been shown to phosphorylate corticosteroid receptors (Dalman *et al.*, 1988; Smith *et al.*, 1989) and convert them to their inactive form (reviewed by Sanchez *et al.*, 1987; Dahlman-Wright *et al.*, 1992), increasing their binding capacity in the cytosol.

Modulation of corticosteroid receptors by neurotransmitters may be the initial phase leading to an eventual shift in HPA axis activity (Kabbaj *et al.*, 1995). For example, activation of 5-HT or NA neurons increases HPA axis activity (Feldman and Weidenfeld, 1995). However, prolonged activation of these receptors have opposite effects on hippocampal corticosteroid receptor binding capacity. NA decreases (Maccari *et al.*, 1992a; Kabbaj *et al.*, 1995) while 5-HT increases (Seckl and Fink, 1991; Budziszewska *et al.*, 1995) corticosteroid receptor levels. Clearly, the selective physiological activation of different neurotransmitter pathways will have different effects on corticosteroid receptor function and may underlie modulatory and pathophysiological processes.

Autoregulation

Receptor autoregulation is a mechanism which occurs for a large number of receptor systems, including corticosteroid receptors (reviewed by Schmidt and Meyer,

1994). A common feature of receptor autoregulation in all systems is a correlation between ligand availability and receptor binding capacity. What is different between receptor systems is how ligand availability and receptor binding correlate (directly or inversely) and their mechanism of autoregulation. An adrenalectomy-induced increase in hippocampal corticosteroid binding capacity was first demonstrated by McEwen *et al.*, (1970). Later, it was reported that corticosteroid receptor binding capacity in the hippocampus was reduced by high levels of corticosterone or stress (Tornello *et al.*, 1982; Sapolsky *et al.*, 1984a). Investigators then sought to determine the individual roles of hippocampal MR and GR in receptor autoregulation and their function in HPA axis feedback.

The binding capacities of MR and GR are differentially regulated by changes in steroid levels. Hippocampal MR binding capacity may either increase (Chao *et al.*, 1989) or show no change (Reul *et al.*, 1987b; Reul *et al.*, 1989; Lowy, 1991; Spencer *et al.*, 1991) with adrenalectomy. MR mRNA levels increase with adrenalectomy (Herman *et al.*, 1989a, 1993). Activation of either MR or GR has different effects on MR binding capacity. The activation of MR does not alter MR binding capacity (Reul *et al.*, 1987b; Spencer *et al.*, 1991) while GR activation alone increases MR binding capacity and mRNA levels (Reul *et al.*, 1987b; Reul *et al.*, 1989). Coactivation of MR and GR decreases MR binding capacity and mRNA levels (Lowy, 1991; Spencer *et al.*, 1991). MR binding capacity and mRNA levels also display circadian variation. However, there

are different reports supporting either a peak- (Reul *et al.*, 1987b) or a nadir-associated (Chao *et al.*, 1989) increase in MR binding capacity during the circadian cycle. MR mRNA levels are higher during the nadir (Herman *et al.*, 1993; Holmes *et al.*, 1995a).

Unlike MR, hippocampal GR binding capacity shows a reproducible increase with adrenalectomy that returns to control levels with corticosterone or dexamethasone treatment (Reul *et al.*, 1987; Chao *et al.*, 1989; Lowy, 1991; Spencer *et al.*, 1991). The adrenalectomy-induced increase in GR binding capacity is also paralleled by an increase in GR mRNA levels (Kalinyak *et al.*, 1987; Herman *et al.*, 1989a, 1993; Reul *et al.*, 1989; Sheppard *et al.*, 1990; Peiffer *et al.*, 1991). GR binding capacity in the hippocampus does not change with diurnal variation (Reul *et al.*, 1987b) but GR mRNA levels are higher during the nadir of the circadian cycle (Herman *et al.*, 1993; Holmes *et al.*, 1995a). In contrast to MR, activating both or each corticosteroid receptor selectively, decreases GR binding capacity in hippocampal sections and tissue culture (Sapolsky *et al.*, 1984a; Sapolsky and McEwen, 1985; Luttge *et al.*, 1989; Vedder *et al.*, 1993; O'Donnell and Meaney, 1994).

Corticosteroid receptor autoregulation does not occur in all brain areas. Adrenalectomy increases MR and GR mRNA levels in the hippocampus and amygdala but not in the hypothalamus, neocortex, dorsomedial thalamus, hypothalamic PVN, and arcuate nucleus (Pfeifer *et al.*, 1991; Herman *et al.*, 1993). Corticosterone decreases corticosteroid receptor binding capacity in the rat hippocampus but not in the

hypothalamus, amygdala, or pituitary (Tornello *et al.*, 1982; Sapolsky and McEwen, 1985). Interestingly, dexamethasone decreases GR binding capacity in the pituitary and amygdala but not in the hippocampus (Sapolsky and McEwen, 1985).

The autoregulation of corticosteroid receptors is an important feedback mechanism (Schmidt and Meyer, 1994). The mechanism underlying corticosteroid receptor autoregulation is complex. Influencing the transcription of their own gene (Burstein *et al.*, 1991), mRNA stability, alternative splicing, and receptor protein turnover rate may all be involved in the autoregulation mechanism (Schmidt and Meyer, 1994; Herman and Watson, 1995). Finally, the pronounced autoregulation of corticosteroid receptors in the hippocampus as compared to other brain areas, supports the important role that the hippocampus has in influencing HPA axis activity and corticosteroid-induced behaviors (Jacobson and Sapolsky, 1991).

Function

It has been proposed by de Kloet (1991) that homeostasis is maintained by MR and GR via a 'corticosteroids receptor balance hypothesis'. This hypothesis simply states that the physiological functions of MR and GR depend on the differential occupation of the two receptors and is based on two important corticosteroid receptor properties. First, MR and GR have different affinities for corticosterone. Second, the fractional occupancy of MR and GR changes with physiological fluctuations in corticosterone plasma concentrations. MR has a high affinity for corticosterone ($K_D = 0.5 - 0.7$ nM)

and is 70-80% occupied at basal physiological corticosterone plasma levels (Krozowski and Funder, 1983; Reul and de Kloet, 1985; Reul *et al.*, 1987). GR has a lower affinity for corticosterone, $K_D = 2.5 - 5$ nM, and its occupancy changes from 15% at basal to 90% at peak and stress circulating corticosterone levels (Reul and de Kloet, 1985; Reul *et al.*, 1987a,b). One important point should be emphasized about the physiological function of MR and GR. GR occupation without concomitant MR occupation has not been demonstrated to occur physiologically.

Brain MR and GR have distinct physiological functions that are often complementary and not antagonistic. For example, MR and GR are important in maintaining homeostasis. However MR maintains ion homeostasis while GR maintains glucose availability (Dallman *et al.*, 1987, 1994; Tempel and Leibowitz, 1994). MR and GR influence different aspects of behavior. MR permits the proper acquisition of behavior reactivity in rats while GR facilitates memory storage (Micco *et al.*, 1980; Jefferys *et al.*, 1983; Veldhuis *et al.*, 1985; McEwen and Brinton 1987; Oitzl and de Kloet, 1992, 1994; de Kloet *et al.*, 1993). One example of the different roles MR and GR have on behavior is the performance of rats in the Morris water maze. MR activation is important in developing the strategy used by the animal to find the platform in the water while GR activation is important for acquiring and storing spatial information (Oitzl and de Kloet, 1992; Oitzl *et al.*, 1994).

Concluding Remarks

MR and GR are intracellular receptors that bind to DNA and regulate the expression of specific genes. MR and GR have different physiological functions. MR and GR also have different affinities for corticosterone. Therefore, homeostasis is maintained by MR and GR via changes in their fractional occupancy with fluctuating corticosteroid plasma levels. MR and GR are differentially expressed in the brain. The hippocampus contains the highest density of MR and GR binding sites and mRNA levels.

Corticosteroid receptor levels are autoregulated and influenced by neuropeptides and neurotransmitters which may represent three different physiological mechanisms underlying the modulation of HPA axis activity. Neuropeptides provide trophic effects which may be important in maintaining normal corticosteroid receptor levels (reviewed by de Kloet *et al.*, 1986a). Neurotransmitters provide a rapid mechanism for modulating corticosteroid receptor levels via the activation of selective neurotransmitter pathways. Finally, corticosteroids autoregulate their own receptor levels, providing a HPA axis feedback mechanism (reviewed by Schmidt and Meyer, 1994). Corticosteroid receptor regulation occurs in several brain areas; however, the hippocampus shows the greatest sensitivity.

Hypothalamic-Pituitary-Adrenal Axis

The synthesis and release of corticosteroids are regulated by the hypothalamic-pituitary-adrenal axis (HPA) (Figure 3) (reviewed by Feldman and Weidenfeld, 1995).

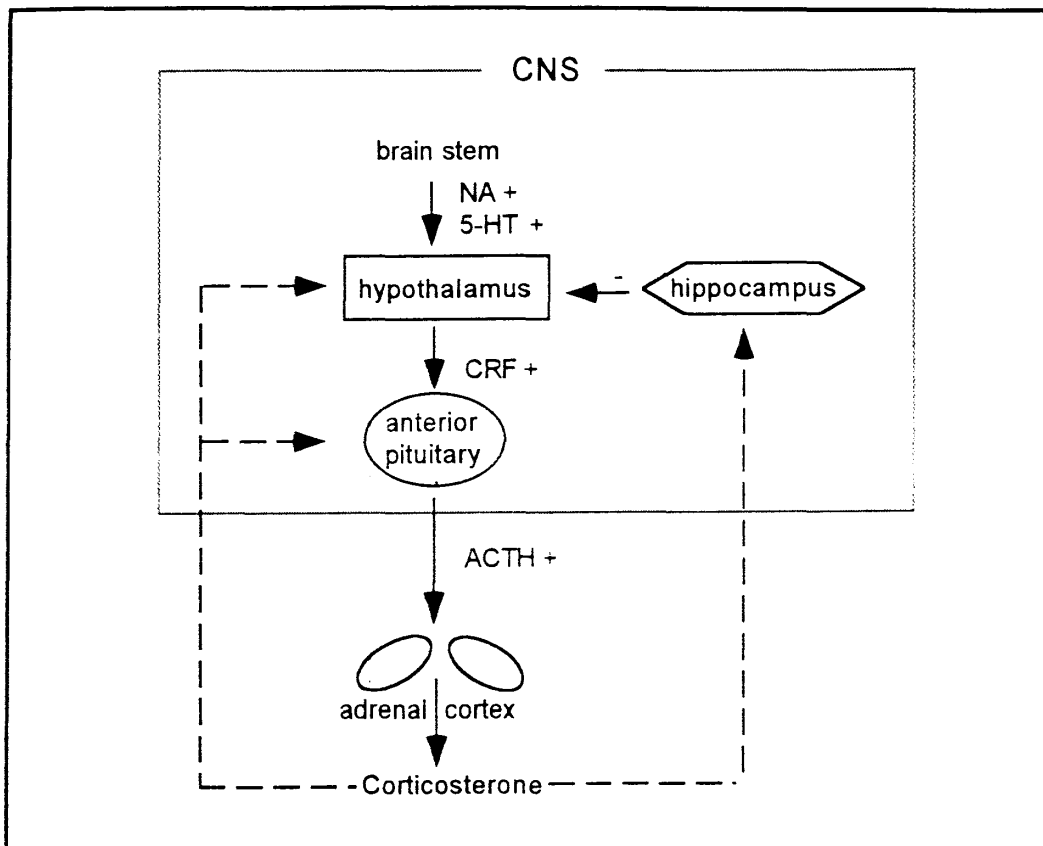

Figure 3. Schematic model of the HPA axis. The major components, peptides, and hormones are pictured in this diagram. The solid arrows depict released constituents, while the broken arrow depicts feedback.

In response to various stimuli, PVN neurons in the hypothalamus release CRF into the portal circulation. CRF then stimulates the synthesis and release of ACTH from the corticotropes in the anterior pituitary. ACTH enters the circulatory system and drives the synthesis and release of corticosteroids from the adrenal cortex.

Regulation of The HPA axis

HPA axis activity is driven by two physiological mechanisms, circadian rhythm and stress. Circulating glucocorticoid levels in nocturnal rats are lowest during 'lights-on', peak during 'lights-off' (Guillemin *et al.*, 1959; Scheving and Pauly, 1966; Zimmermann and Critchlow, 1967; Ader *et al.*, 1968; Retiene, 1970; Dunn *et al.*, 1972), and increase in response to stress (Ganong, 1963; Mangili *et al.*, 1966; Yates, 1967; Ader *et al.*, 1968; Gibbs, 1970; Dunn *et al.*, 1972). It is well established that extrahypothalamic structures regulate circadian rhythm and stress-induced HPA axis activity (Slusher, 1964; Davidson and Feldman, 1967; Halász *et al.*, 1967; Palka *et al.*, 1969; Wilson and Critchlow, 1975; Phelps *et al.*, 1978). Extrahypothalamic structures affect HPA axis activity through the release of vasopressin, oxytocin, epinephrine or 5-HT at the hypothalamus (Weiner and Ganong, 1978; Fuller, 1981; Swanson *et al.*, 1983; Plotsky 1985, 1987; Antoni, 1986; Plotsky *et al.*, 1987, 1989; Feldman *et al.*, 1990, Feldman and Weidenfeld, 1991).

Neurotransmitter Systems Influencing HPA Axis Activity

5-HT neurons arising from raphe nuclei innervate the parvocellular region of the PVN in the hypothalamus (Palkovits *et al.*, 1977; Sawchenko *et al.*, 1983). 5-HT neurons innervate CRF synthesizing neurons in the PVN (Lipositis *et al.*, 1987) and stimulate the synthesis and release of CRF *in vivo* (Saphier and Feldman, 1989; Swanson and Simmons, 1989; Feldman *et al.*, 1991) and from isolated rat hypothalamic cells (Calogero *et al.*, 1989).

5-HT neurons facilitate circadian- and stress-induced release of CRF or corticosterone (Szafarczyk *et al.*, 1980; Fuller, 1981; Feldman *et al.*, 1995). The 5-HT receptors mediating the release of CRF, ACTH or corticosterone are the 5-HT_{1A} and 5-HT₂ receptors (Koenig *et al.*, 1987, 1988; Lorens and Van de Kar, 1987; Gilbert *et al.*, 1988; King *et al.*, 1989; Fuller and Snoddy, 1990).

NA fibers located in the ventral noradrenergic ascending bundle (VNAB) have an important role in regulating HPA axis activity (Feldman *et al.*, 1984; Plotsky *et al.*, 1989; Feldman and Weidenfeld, 1995, Feldman *et al.*, 1995). VNAB fibers originate in the brainstem, mainly from the locus coeruleus. A subset of these fibers innervate the hypothalamic PVN, via the medial forebrain bundle (Cunningham and Sawchenko, 1988; Cunningham *et al.*, 1990; Saphier and Feldman, 1991), and stimulate CRF release (Guillaume *et al.*, 1987; Plotsky, 1987; Weidenfeld and Feldman, 1991b).

Lesioning the VNAB or medial forebrain bundle with the catecholamine neurotoxin 6-hydroxy-dopamine (6-OHDA) prevents the circadian release of ACTH and corticosterone (Szafarczyk *et al.*, 1985) and the stress-induced release of CRF (Feldman *et al.*, 1984; Szafarczyk *et al.*, 1985,1987; Plotsky, 1987; Sawchenko, 1988). The NA receptors mediating the release of CRF are the α_1 - and α_2 -receptors (Saphier and Feldman, 1991; Daniels *et al.*, 1993).

The cholinergic system also influences HPA axis activity. Cholinergic agonists stimulate CRF, ACTH, and corticosterone release (Makara and Stark, 1976; Plotsky *et al.*, 1987; Weidenfeld *et al.*, 1989a). Cholinergic antagonists attenuated both basal- and stress-induced release of ACTH (Hedge and Smelik, 1968; Kaplanski and Smelik, 1973; Makara and Stark, 1976; Guillaume *et al.*, 1987). The cholinergic receptors mediating the release of corticosterone are nicotinic receptors (Brenner *et al.*, 1986; Weidenfeld *et al.*, 1989a).

Feedback Regulation by Corticosteroids

While extrahypothalamic pathways are important for the initial stimulation (or inhibition) of HPA axis activity, more direct control of the HPA axis is mediated through feedback loops within the axis (**Figure 3**) (reviewed by Feldman and Weidenfeld, 1995). Corticosteroids act at both the hypothalamus and pituitary to directly inhibit their own synthesis and secretion. Some controversy still exists surrounding the mechanism by which corticosteroids directly act at the hypothalamus to decrease ACTH secretion

(reviewed by Bradbury *et al.*, 1991; Dallman *et al.*, 1994; Feldman *et al.*, 1995).

Corticosteroid receptors and CRF are both present within the same cells in the PVN (Ceccatelli *et al.*, 1989). Adrenalectomy or stress (initiated via photic, acoustic, or sciatic nerve stimulation) increases hypothalamic CRF peptide and mRNA levels (Paull and Gibbs; 1983; Westlund *et al.*, 1985; Plotsky and Sawchenko, 1987; Sawchenko, 1987; Beyer *et al.*, 1988; Fink *et al.*, 1988; Weidenfeld *et al.*, 1989b; Feldman *et al.*, 1992; Kwak *et al.*, 1993), resulting in an increase in ACTH secretion from the pituitary. However, corticosteroid implants in the hypothalamus attenuated only the neural (photic) stimulated CRF mRNA levels and peptide secretion (Feldman *et al.*, 1992) and did not reliably decrease the adrenalectomy stimulated ACTH secretion in animals (Dallman *et al.*, 1985; Kovacs *et al.*, 1986; Sawchenko, 1987; Kovacs and Makara, 1988; Levin *et al.*, 1988). Therefore, HPA axis feedback inhibition may occur at other brain sites in addition to the hypothalamus (Feldman *et al.*, 1992).

Corticosteroids also act in the pituitary to inhibit ACTH secretion (reviewed by Dallman *et al.*, 1987). GR and ACTH are both localized within the same cells in the pituitary (Cintra and Bortolotti, 1992). Corticosteroids decrease CRF- (Koch *et al.*, 1979; Dallman *et al.*, 1985), adrenergic- (Giguere *et al.*, 1982), and stress- (Walker *et al.*, 1986) stimulated ACTH release from the pituitary. The inhibitory effect of corticosteroids on ACTH secretion occurs within 10-30 min (Brattin and Portanova, 1977; Buckingham and Hodges, 1977; Mulder and Smelik, 1977; Gilles and Lowry,

1978; Widmaier and Dallman, 1984; Abou-Samra *et al.*, 1986; Dayanithi and Antoni, 1989) and requires protein synthesis (Dayanithi and Antoni, 1989). The requirement for protein synthesis suggests that corticosteroids decrease CRF and/or ACTH synthesis by increasing the synthesis of inhibitory transcription factors (Dayanithi and Antoni, 1989).

MR and GR have different roles in HPA axis feedback (Dallman *et al.*, 1987, 1994; de Kloet and Reul, 1987; Dayanithi and Antoni, 1989; Ratka *et al.*, 1989; Sapolsky *et al.*, 1990; Bradbury *et al.*, 1991, 1994). MRs mediate HPA axis feedback inhibition during the circadian trough, when MR is 70-80% occupied at basal physiological corticosterone plasma levels (Krozowski and Funder, 1983; Reul and de Kloet, 1985; Reul *et al.*, 1987a,b). GRs mediate HPA axis negative feedback regulation during the diurnal peak or stress, when its occupancy changes from 15% at basal to 90% at peak and stress circulating corticosterone levels (Reul and de Kloet, 1985; Reul *et al.*, 1987a,b).

Interestingly, the hypothalamus-pituitary brain areas are important in feedback during the circadian trough while other brain areas are important during the peak (Akana *et al.*, 1986; Suemaru *et al.*, 1995). Stress-induced increase in HPA axis activity is mediated through several different neural pathways (Feldman, 1985; Canny *et al.*, 1989) and feedback is provided by both the HPA axis and other cortical areas (Kaneko and Hiroshige, 1978a,b; Keller-Wood and Dallman 1984; Dallman *et al.*, 1987; Canny *et al.*, 1989).

The Hippocampus and HPA Axis Feedback Regulation

The hippocampus has a significant role in regulating HPA axis activity. While it is well established that the hippocampus is a site of negative feedback for the HPA axis, it is not known how the hippocampus exerts its influence on the axis (reviewed by Jacobson and Sapolsky, 1991). The neural circuit in the hippocampus is complex. The hippocampal structure is divided into different regions: hippocampus proper, dentate gyrus, and subiculum. These regions are interconnected to form the hippocampal circuitry. The neurons within these regions have different cell properties, neurotransmitter receptor-mediated responses, and when these regions are stimulated their effects on HPA axis activity are not the same.

Hippocampal Anatomy

The hippocampus is divided into three regions; hippocampus proper, dentate gyrus, and the subiculum (reviewed by Knowles, 1992; Bernard and Wheal, 1994). The hippocampus proper is further divided into several subfields, CA1-4. Pyramidal cells are the primary projection neurons in the hippocampal subfields (Knowles, 1992; Bernard and Wheal, 1994) and share the same general shape as the pyramidal cells in the cortex (Peters and Jones, 1984). They have triangular or ovoid shaped cell bodies with one to three long apical dendrites. There are also a wide variety of interneurons in the hippocampus. The interneurons mainly release γ -aminobutyric acid (GABA) as their neurotransmitter and are classified by their shape, neurophysiology, and location

(Knowles, 1992; Bernard and Wheal, 1994).

The hippocampal circuitry is established through a hierarchy of connections that produce unidirectional signal processing within the structure (Andersen *et al.*, 1971b; Andersen, 1975; Bernard and Wheal, 1994). **Figure 4** illustrates a diagrammatic model of the trisynaptic circuit. The major hippocampal inputs are received at the dentate gyrus granule cells from the entorhinal cortex through the perforant pathway. Mossy fibers from the dentate gyrus project to subfield CA3 pyramidal cells, which in turn, send Schaffer collaterals to subfield CA1 pyramidal cells. Subfield CA1 cells then provide the major output for the hippocampus through the fornix and subiculum.

There are several important differences in the cellular organization and physiology between the various subfields. The pyramidal cells in subfield CA3 are larger and more densely packed compared to the cells in subfield CA1 (Knowles, 1992). The pyramidal cells in subfields CA1 and CA3 are interconnected differently. The pyramidal cells in subfield CA3 are highly interconnected with nearby pyramidal cells and interneurons through an extensive local network of axon collaterals (Miles and Wong, 1986; Ishizuka *et al.*, 1990). In contrast, the pyramidal neurons in subfield CA1 have few excitatory collaterals between neighboring pyramidal cells (Knowles and Schwartzkroin, 1981a,b). The extensive interconnection of cells in subfield CA3 are hypothesized to be important in the synchronized burst firing of these cells (Miles and Wong, 1986; Ishizuka *et al.*, 1990).

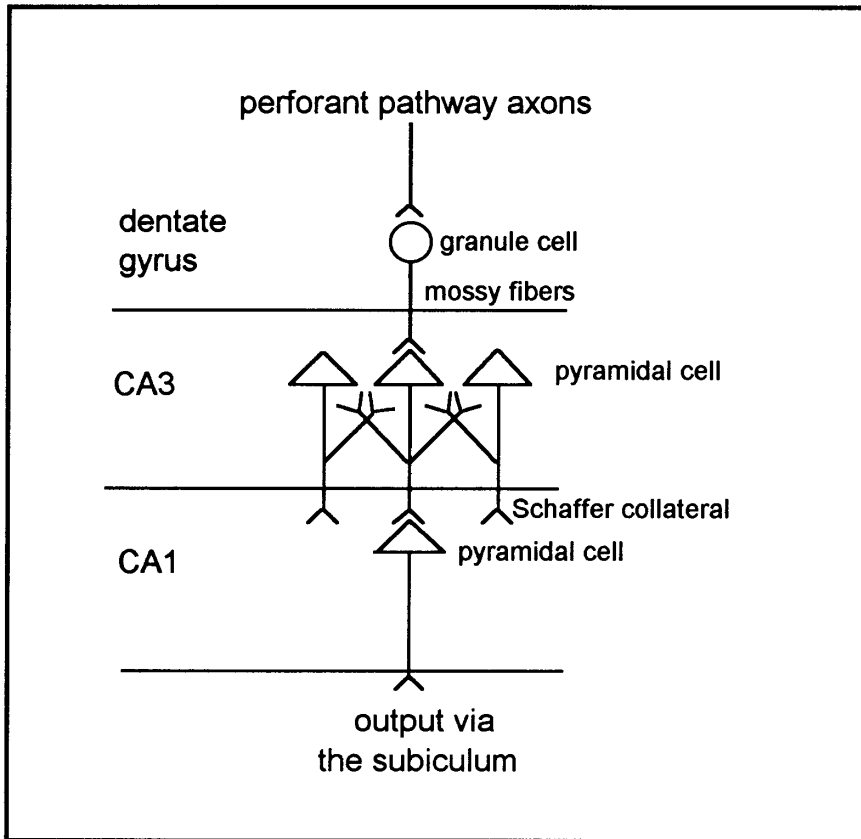

Figure 4. Schematic representation of the hippocampal trisynaptic circuit. Only the major cell types, projections, and synapses are depicted in this diagram.

Hippocampal pyramidal cell excitability is determined by at least two factors: membrane electrical properties and neurotransmitter responses and both of these factors are different among the various subfields. For example, in subfields CA1 and CA3, the pyramidal cell's passive and active membrane properties are different (Nunez *et al.*, 1990; Beck *et al.*, 1992; Spruston and Johnston, 1992). Therefore, the cells in these two subfields may integrate synaptic potentials and encode their outputs differently. The responses elicited by the activation of at least two neurotransmitter receptors are different between subfield CA1 and CA3. The 5-HT or baclofen concentration-response curve characteristics for the 5-HT_{1A} and γ -aminobutyric acid_B (GABA_B) receptors, respectively, are different between subfields CA1 and CA3 (Beck *et al.*, 1992, 1995).

Corticosteroid Receptor Distribution and Regulation in the Hippocampus

There is some uncertainty concerning the relative distribution of corticosteroid receptors in the individual hippocampal subfields. Based on radioligand binding assays, MR binding density is greatest in subfield CA1 and least in subfield CA3. This is also supported by *in situ* hybridization and immunohistochemistry investigations with probes for the MR mRNA and protein (Arriza *et al.*, 1988; Van Eekelen *et al.*, 1988; Herman *et al.*, 1989a; Ahima *et al.*, 1991). GR binding density is higher in subfield CA3 compared to CA1. However, the results from *in situ* hybridization and immunohistochemistry experiments indicate that subfield CA3 has very little GR mRNA and immunoreactivity

(Fuxe *et al.*, 1985; Van Eekelen *et al.*, 1988; Herman *et al.*, 1989a). In a recent immunohistochemistry investigation, Ahima and Harlan (1990) reported that GR labeling is equally intense throughout subfields CA1-CA3. There has been no attempts to resolve the differences in GR binding, immunoreactivity, and mRNA distribution in the hippocampus. Some of the possible explanations for the disparate results are differences in GR mRNA translation, stability, or post-translation modifications between subfields CA1 and CA3 (Herman *et al.*, 1989a).

As reviewed above, the hippocampus is highly sensitive to corticosteroid receptor autoregulation compared to other brain areas. Interestingly, corticosteroid receptor autoregulation in the hippocampus is different between subfields CA1 and CA3. Corticosterone decreases corticosteroid receptor binding sites in hippocampal subfields CA1 and CA2, not in CA3 (Sapolsky and McEwen, 1985). Adrenalectomy increases GR and MR mRNA levels in subfield CA1 but not in subfield CA3 (Herman *et al.*, 1989a).

Hippocampus Influence on HPA Axis Activity

Based on several lines of evidence, the hippocampus is an important site for HPA axis negative feedback regulation. First, corticosterone is capable of decreasing its own release by acting through the hippocampus. Corticosterone or dexamethasone implants into the dorsal hippocampus decreases adrenalectomy-induced ACTH secretion (Davidson and Feldman, 1967; Kovacs and Makara, 1988). Second, the hippocampus

exerts a negative influence on HPA axis activity. Dorsal hippocampectomy decreases the diurnal variation in circulating corticosterone levels by increasing basal (nadir) ACTH and corticosterone plasma levels (Fendler *et al.*, 1961; Moberg *et al.*, 1971; Fischette *et al.*, 1980; Wilson *et al.*, 1980; Margarinos *et al.*, 1987; Sapolsky *et al.*, 1989;). Hippocampectomy also increases CRF and vasopressin mRNA levels in the PVN (Herman *et al.*, 1989b, 1992).

Hippocampal lesions alter stress-induced HPA axis activity (Sapolsky *et al.*, 1984b). Corticosterone levels increase during stress and return to pre-stress levels approximately one hour after the stressor is terminated (Sapolsky *et al.*, 1984b). Rats with hippocampal lesions have higher circulating plasma corticosterone levels in response to stress and the high level is maintained for at least four hours after the stressor is terminated (Kant *et al.*, 1984; Sapolsky *et al.*, 1984b). A common test for corticosterone feedback inhibition is the use of dexamethasone to suppress the stress-induced corticosterone secretion in rats. When the hippocampus or fornix are lesioned, the efficacy of dexamethasone to suppress stress-induced corticosterone secretion is significantly diminished (Feldman and Conforti, 1976; Margarinos *et al.*, 1987).

Finally, hippocampal regulation of the HPA axis is also supported by investigations using electrical stimulation of the hippocampus. Electrical stimulation of subfield CA2-CA3 or the dentate gyrus decreases while stimulating subfield CA1 increases plasma

corticosterone levels in rats (Kawakami *et al.*, 1968; Dunn and Orr, 1984; Daniels *et al.*, 1994).

Concluding Remarks

Several lines of evidence suggest that corticosteroids have an important role in modulating hippocampal neural activity. The hippocampus has the highest density of corticosteroid receptors in the brain. The distribution of MR and GR may be different between subfields CA1 and CA3; therefore, the two receptors may selectively modulate the hippocampal circuitry at specific sites. The hippocampus is a site of HPA axis negative feedback, influencing both circadian and stress driven corticosteroid secretion. However, it is not known how the feedback signal is processed in the hippocampus. Neuronal signal processing in the hippocampus is complex and corticosteroid modification of hippocampal neural activity is not completely understood.

Corticosteroid Modulation of Hippocampal Neuron Properties

Neuron Membrane Electrical Properties

One way that corticosteroids may influence signal processing in the hippocampus is by modulating the electrical properties of hippocampal neurons. Indeed, it has been demonstrated that corticosteroids alter neuron membrane electrical properties in hippocampal CA1 pyramidal cells. Chronic (two weeks) MR activation with basal levels of corticosterone increases the membrane input resistance and time constant of pyramidal

cells in subfield CA1 (Beck *et al.*, 1994). The membrane input resistance and time constant determine the decay of synaptic potentials in the dendrites and soma, which in turn, influences the integration of postsynaptic potentials in the cell (Rall, 1977).

Therefore, corticosteroids may alter the integration of postsynaptic potentials in subfield CA1 cells.

Chronic MR activation with basal levels of corticosterone also increases the action potential peak amplitude and duration (Beck *et al.*, 1994). Altering the shape of the action potential may be physiologically important. Wheeler *et al.*, (1996) recently reported that increasing the action potential duration leads to an increase in Ca^{2+} influx at the presynaptic terminal and enhances synaptic strength. Consequently, MR activation in subfield CA1 neurons may increase the release of neurotransmitters at the nerve terminal.

Corticosteroids alter two characteristics that rely on a Ca^{2+} -dependent K^+ current: spike accommodation and slow afterhyperpolarization (sAHP) (Madison and Nicoll, 1984; Lancaster and Nicoll, 1987). When a prolonged (300 - 500 ms) depolarizing current pulse is injected into hippocampal pyramidal cells, the cell fires a short train of action potentials at the beginning of the pulse. The frequency of action potentials then decreases over the duration of the pulse. Accommodation is a term used to describe the neuron's ability to adapt and prevent the firing of action potentials during the depolarizing pulse. Once the depolarizing pulse is terminated, a sAHP is apparent. Accommodation is determined by the magnitude and duration of the sAHP.

In subfield CA1, the sAHP is smaller in cells from adrenalectomized animals compared to cells from adrenally-intact animals (Joëls and de Kloet, 1989; Kerr *et al.*, 1989). Short term (20 min to 4 hrs) and chronic MR activation decreases spike accommodation and the sAHP (Joëls and de Kloet, 1989,1990; Kerr *et al.*,1989; Beck *et al.*,1994). MR and GR activation or GR activation alone increases accommodation and the sAHP (Joëls and de Kloet, 1989,1990; Kerr *et al.*, 1989).

The actions of corticosteroids on several ionic conductances in the hippocampus have also been examined. The L- and T- type Ca^{2+} currents are larger in cells from adrenalectomized as compared to intact animals (Karst and Joëls, 1994). Short-term MR activation returns the magnitude of the L- and T- type Ca^{2+} currents to control values (Karst and Joëls, 1994). Due to conflicting reports, the effects of GR activation on Ca^{2+} currents in the hippocampus is still unclear. There are reports that GR activation induces either larger (Kerr *et al.*, 1992) or smaller (Karst and Joëls, 1994) Ca^{2+} currents in subfield CA1 pyramidal cells compared to cells from adrenalectomized animals. I_Q is also modulated by MR and GR activation. The I_Q current is small when either MR or GR are occupied alone but increases when both MR and GR are occupied (Karst *et al.*, 1993).

Hippocampus 5-HT_{1A} Signal Transduction System in Subfields CA1 and CA3

In addition to altering cell membrane electrical properties, corticosteroids may also influence neural activity by modulating the responses elicited by the activation of neurotransmitter receptors. Corticosteroids have been shown to modulate neurotransmitter receptor systems in the brain including NA, muscarinic, glutamate, and 5-HT systems (reviewed by Joëls and de Kloet, 1994; McEwen, 1996). The action of corticosteroids on the 5-HT_{1A} receptor system has been reported by several different groups (Joëls and de Kloet, 1994; Chaouloff, 1995; Beck *et al.*, 1996). However, the mechanism by which corticosteroids alter the responses elicited by the activation of the 5-HT_{1A} receptor is still not known. One reason the mechanism remains elusive is the effects of corticosteroids on the different components of the 5-HT_{1A} receptor signal transduction pathway are not known.

The hippocampus receives an extensive 5-HT innervation from the dorsal and median raphe (Azmitia and Segal 1978; Molliver, 1987). Stimulation of ascending 5-HT containing axons from the raphe decreases the cell firing rate of hippocampal subfield CA3 pyramidal cells (Segal, 1975). Locally applied 5-HT also decreases pyramidal cell firing rate (De Montigny and Aghajanian, 1978; Otmakhov and Bragin, 1982). Activation of the 5-HT_{1A} receptor in the hippocampus hyperpolarizes the cell membrane potential (Andrade and Nicoll, 1987; Colino and Haliwell, 1987; Beck and Choi, 1991; Beck *et al.*, 1992). The 5-HT_{1A} receptor signal transduction system mediating the

hyperpolarization is composed of a receptor, heterotrimeric guanine nucleotide binding protein (G protein), and potassium channel (Andrade *et al.*, 1986; Okuhara and Beck, 1994).

5-HT_{1A} Receptor Structure and Distribution

The 5-HT_{1A} receptor belongs to the family of G protein-coupled receptors (reviewed by Iismaa and Shrine, 1992). G protein-coupled receptors are single chain polypeptides that contain seven putative membrane-spanning domains. The human 5-HT_{1A} receptor was first cloned in the late 1980's (Kobilka *et al.*, 1987; Fargin *et al.*, 1988). The rat 5-HT_{1A} receptor was later cloned by two separate groups (Albert *et al.*, 1990; Fujiwara *et al.*, 1990) and encoded a protein approximately 420 amino acids in length.

There are three important features of G protein-coupled receptors which is also shared by the 5-HT_{1A} receptor. First, the three dimensional arrangement of the seven transmembrane domains are proposed to form a ligand binding pocket (Hartig, 1989; Sylte *et al.*, 1993) (**Figure 5**). The three dimensional arrangement places specific amino acid residues, located within the transmembrane domains, in areas critical for the interaction with receptor agonists and antagonists (Guan *et al.*, 1992; Ho *et al.*, 1992; Chanda *et al.*, 1993). Second, the third cytoplasmic loop is the proposed site where G protein coupling occurs. The amino acids in the third cytoplasmic loop are highly divergent as compared with other G protein-coupled receptors (El Mestikawy *et al.*,

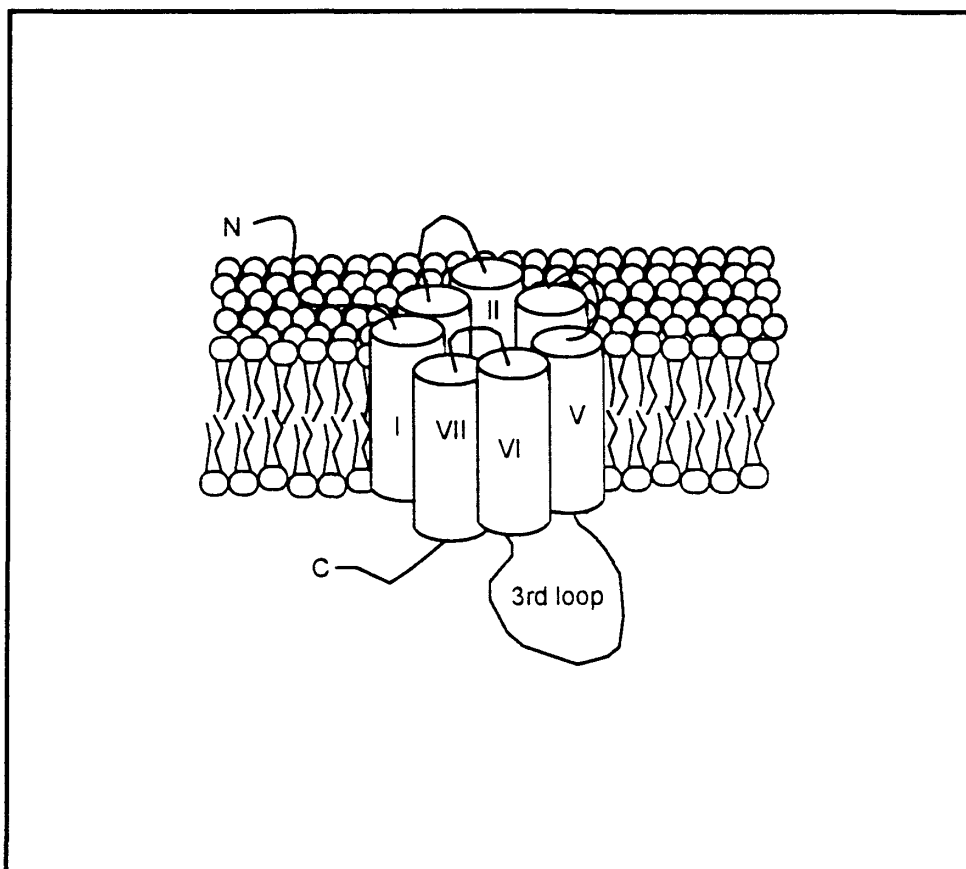

Figure 5. Diagrammatic representation of the 5-HT_{1A} receptor. The seven transmembrane regions (cylinders labeled in roman numerals) are shown in a hypothetical arrangement. The amino terminal (N) is located outside the cell while the carboxy terminal (C) is in the cytoplasm. The third cytoplasmic loop is also displayed.

1991). The amino acids bordering each end of the third cytoplasmic loop are thought to confer G protein selectivity (Strader *et al.*, 1987; Kobilka *et al.*, 1988; O'Dowd *et al.*, 1988). Finally, 5-HT_{1A} receptor binding is modulated by phosphorylation. In a cell line where the 5-HT_{1A} receptor was stably transfected, protein kinase C activation phosphorylated and desensitized the receptor (Raymond, 1991).

The 5-HT_{1A} receptor is expressed through out the periphery and brain. The distribution of 5-HT_{1A} receptors has been examined in several mammalian species (i.e., rat, pig, cat, mouse, and human) with similar results. The highest density of 5-HT_{1A} binding sites and mRNA are located in limbic system structures: hippocampus, amygdala, septum, and cortical limbic areas (reviewed by Zifa and Fillion, 1992; Boess and Martin, 1994). Within the hippocampus, the number of 5-HT_{1A} receptor binding sites is different between subfields CA1 and CA3. Subfield CA1 has approximately a two times higher density of receptor binding sites compared to CA3 (Vergé *et al.*, 1986; Radja *et al.*, 1991).

G protein Structure and Function

G proteins are heterotrimeric proteins that bind guanine nucleotides (reviewed by Birnbaumer and Birnbaumer, 1995). G proteins that are involved in receptor signal transduction systems function as transducers. These G proteins couple, or link, the activation of specific plasma membrane receptors to other cellular proteins (commonly referred to as effector proteins) located within the membrane.

The G protein complex is composed of three subunits: α , β , and γ . The α -subunit binds to guanosine triphosphate (GTP) and hydrolyzes it to guanosine diphosphate (GDP). The α -GTP complex is capable of dissociating from the $\beta\gamma$ subunits (Fung, 1983; Northup *et al.*, 1983a,b). The $\beta\gamma$ subunits anchor the G protein complex to the plasma membrane and facilitates the interaction between G proteins and receptors (Kanaho *et al.*, 1984; Florio and Sternweis, 1985, 1989; Watkins *et al.*, 1985; Navon and Fung, 1987). All three subunits have been reported to interact with effector molecules (reviewed by Birnbaumer, 1992; Birnbaumer and Birnbaumer, 1995). There are at least three major G protein families; G_s , G_i , and G_q . The G protein families, and their respective subtypes, were originally classified by their ability to either stimulate (G_s) or inhibit (G_i) adenylyl cyclase, or other effector molecules. Presently, they are classified by their α -subunit sequences (reviewed by Birnbaumer *et al.*, 1990).

Activation of receptors coupled to G proteins initiates a cycle which is the hallmark of G protein-coupled receptor signal transduction systems (reviewed by Birnbaumer and Birnbaumer, 1995). The signal transduction cycle is described in **Figure 6**. The activated receptor couples with a G protein. The G protein α -subunit binds a molecule of GTP and begins to hydrolyze it to GDP. The α -GTP complex dissociates from the $\beta\gamma$ subunits. The α -GTP and/or $\beta\gamma$ subunits interact with effector molecules. The hydrolysis of GTP to GDP terminates the interaction of the α -subunit with the effector molecule and the $\alpha\beta\gamma$ complex is reformed.

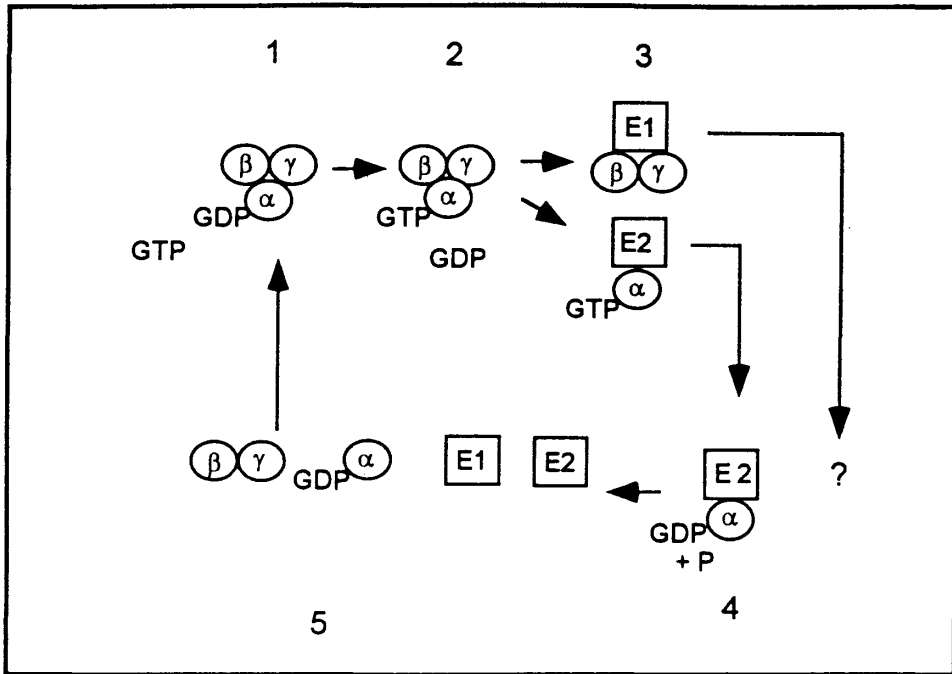

Figure 6. Cartoon illustration of the G protein cycle. 1. The activated receptor couples with the inactive G protein (GDP bound to the α -subunit). 2. The G protein α -subunit binds a molecule of GTP and begins to hydrolyze it to GDP. 3. The α -GTP complex dissociates from the $\beta\gamma$ subunits. The α -GTP and/or $\beta\gamma$ subunits interact with their effector proteins (E1 and E2). 4. The hydrolysis of GTP to GDP terminates the interaction of the α -subunit with the effector molecule. The mechanism (?) underlying the dissociation of the $\beta\gamma$ subunits from their effector molecule is not known. 5. The G protein subunits dissociate from their effector proteins and reform the $\alpha\beta\gamma$ complex.

A tool that is commonly used to determine which G protein subtypes are involved in a receptor signal transduction system is the *Bordetella pertussis* toxin (PTX). PTX covalently modifies (process known as ADP-ribosylation) particular G protein α -subunits (i.e., G_i and G_o , not G_s) and inhibits the coupling between the receptor and G protein (Gilman, 1984; Watkins *et al.*, 1985). Using PTX, it was demonstrated that the 5-HT_{1A} receptor couples to a PTX-sensitive G protein in hippocampal subfields CA1 and CA3 (Andrade *et al.*, 1986; Okuhara and Beck, 1994).

Potassium Channel Linked to the 5-HT_{1A} receptor

Activation of the 5-HT_{1A} receptor on hippocampal subfield CA1 pyramidal cells evokes an inward rectifying potassium current that hyperpolarizes the cell membrane potential (Andrade and Nicoll, 1987; Colino and Haliwell, 1987; Beck *et al.*, 1992). Activation of the 5-HT_{1A} receptor on subfield CA3 pyramidal cells also produces a hyperpolarization via an increase in an inward rectifying potassium current (Beck and Choi, 1991; Beck *et al.*, 1992; Okuhara and Beck, 1994).

Very little is known about the potassium channel linked to the 5-HT_{1A} receptor signal transduction system. The channel is probably a member of the recently cloned G protein inward rectifying potassium (GIRK) channel family (Lesage *et al.*, 1994, 1995; Kobayashi *et al.*, 1995; Ponce *et al.*, 1996; Spausches *et al.*, 1996). The potassium channels linked to the 5-HT_{1A} receptor in subfield CA1 appear to be activated by

G protein $\beta\gamma$ subunits, and the channel gating kinetics modified by ATP (Oh *et al.*, 1995).

While the 5-HT_{1A} receptor signal transduction system is composed of similar components in subfields CA1 and CA3, the pharmacological properties of the receptor is different between the two subfields. For example, 5-HT is less potent and elicits a greater hyperpolarization response in subfield CA3 cells compared to cells from subfield CA1 (Beck *et al.*, 1992). 5-HT_{1A} receptor antagonist that are competitive in subfield CA1 are insurmountable in subfield CA3 (Beck *et al.*, 1992). The different pharmacological properties of the 5-HT_{1A} receptor signal transduction system in subfield CA1 and CA3 may be due to differences in signal transduction components (i.e., G protein or potassium channel subtype) or coupling affinity between components.

Corticosteroid Modulation of the 5-HT_{1A} Receptor System in Subfield CA1

Corticosteroids modulate the 5-HT_{1A} receptor system in the hippocampus. Short-term (20 min to 4 hrs) activation of MR with basal levels of corticosterone or aldosterone decreases the 5-HT_{1A} receptor-mediated hyperpolarization compared to cells from adrenalectomy or sham animals (Joëls *et al.*, 1991, Joëls and de Kloet, 1992; Beck *et al.*, 1996). Short-term GR activation does not affect the magnitude of the 5-HT_{1A} receptor-mediated hyperpolarization (Joëls and de Kloet, 1992; Beck *et al.*, 1996) but increases the EC₅₀ value of the 5-HT concentration-response curve (Beck *et al.*, 1996).

Due to conflicting results, the effects of corticosteroids on the number of 5-HT_{1A} binding sites is not clear. Adrenalectomy either increases (Chalmers *et al.*, 1993; Tejani-Butt and Labow, 1994) or has no effect on the number of 5-HT_{1A} binding sites in subfield CA1 (de Kloet *et al.*, 1986b; Mendelson and McEwen, 1992a,b; Meijer and de Kloet, 1994; Kuroda *et al.*, 1994; Holmes *et al.*, 1995b). In the reports where adrenalectomy increased the number of 5-HT_{1A} binding sites, corticosterone treatment reversed the adrenalectomy-induced effect.

The corticosteroid-induced alterations in the 5-HT_{1A} receptor-mediated responses cannot always be explained by changes in the number of 5-HT_{1A} receptor binding sites. For example, an increase in the number of 5-HT_{1A} receptor binding sites (Chalmers *et al.*, 1993; Tejani-Butt and Labow, 1994) in adrenalectomized animals would predict a greater or more sensitive 5-HT_{1A} receptor-mediated response. However, there is no difference in the 5-HT_{1A} receptor-mediated hyperpolarization between adrenalectomized and adrenally-intact animals (Joëls *et al.*, 1991, Joëls and de Kloet, 1992; Beck *et al.*, 1996). Therefore, corticosteroids may be altering the 5-HT_{1A} receptor signal transduction system at sites downstream of the receptor.

In addition to changes in the number of 5-HT_{1A} receptor binding sites, corticosteroids may alter G protein expression or activity. The regulation of G protein levels by glucocorticoids has been examined in several tissue types including liver (Kawai *et al.*, 93), aorta (Haigh *et al.*, 1990) vascular smooth muscle (Schelling *et al.*, 1994),

fetal forebrain tissue (Slotkin *et al.*, 1994), cortex (Saito *et al.*, 1989), and hippocampus (Wolfgang *et al.*, 1994; Gannon *et al.*, 1995).

The action of glucocorticoids on G protein expression is different in the cortex and hippocampus. In the cerebral cortex, adrenalectomy decreases G_i , increases G_s , and has no effect on G_o α -subunit levels when compared to sham (Saito *et al.*, 1989).

Corticosterone replacement reversed the adrenalectomy-induced effects on G protein levels in the cortex. In contrast to the cortex, adrenalectomy has no effect on G_i and G_s α -subunit levels in the hippocampus (Gannon *et al.*, 1994). Only one study has examined the effects of high corticosteroid exposure on G protein levels in the hippocampus. Chronic stress increases G_s and G_o but does not affect G_i α -subunit levels (Wolfgang *et al.*, 1994).

Finally, corticosteroids may also alter effector molecule activity. To date, corticosteroid-induced changes were only examined in effector proteins that regulate second messenger production. For example, glucocorticoids alter adenylyl cyclase activity and mRNA levels in the rat hippocampus (Gannon *et al.*, 1994; Wolfgang *et al.*, 1994). The effects of corticosteroids on the properties of the potassium channel linked to the 5-HT_{1A} receptor signal transduction system in the hippocampus are not known.

Concluding Remarks

Corticosteroids modulate hippocampal neural activity at two known levels. First corticosteroids alter the electrical membrane properties of pyramidal cells. Second they modulate the responses elicited by the activation of neurotransmitter receptors. Current research has focused on the action of corticosteroids on the electrical membrane properties and responses elicited by the activation of the 5-HT_{1A} receptor on hippocampal pyramidal cells in subfields CA1. Nothing is known about effects of corticosteroids on the electrical membrane properties and 5-HT_{1A} receptor-mediated responses in subfield CA3. This deficiency of information makes it difficult to elucidate the role of corticosteroids in hippocampal information processing. As reviewed in the previous section (The Hippocampus and HPA Axis Feedback Regulation) signals in the hippocampus are processed along a trisynaptic pathway; the neurons and the local network in each subfield have distinct properties. Therefore, it is important to determine the effects of corticosteroids in each subfield to understand how neural signaling in the hippocampus is influenced by the steroids.

Clinical Importance

Corticosteroids maintain homeostasis by regulating sugar metabolism, ion balance, immune responses and the responses to stress. Prolonged altered corticosteroid secretion induces pathological conditions that often become neurotoxic (Uno *et al.*, 1994). There are several conditions that are associated with altered corticosterone secretion including

prolonged or chronic stress, senescence, and depression. The following section reviews the current information on stress, senescence, and depression and their relationship to corticosteroids.

Stress

One of the key physiological responses to stress is an increase in corticosteroid secretion, thereby increasing energy sources and limiting non-vital processes (Selye, 1936, 1946; Munck *et al.*, 1984). Normally, corticosterone levels are brought back to basal levels through feedback regulation. Prolonged stress is known to produce brain damage and psychiatric disorders (reviewed by Sapolsky, 1992). Cerebral cortical atrophy and hippocampal cell loss are commonly found in the brains of torture or abuse victims (Jensen *et al.*, 1982; Uno *et al.*, 1989). Cognitive functions are also disrupted with prolonged stress (reviewed by McEwen and Sapolsky, 1995). For example, certain types of learning and memory performances are impaired in rats exposed to repeated stress (Luine *et al.*, 1994a,b).

Hippocampal neurons are particularly sensitive to prolonged stress and high concentrations of glucocorticoids. Stress or high glucocorticoid levels induces neuronal cell loss, (Sapolsky *et al.*, 1985a; Uno *et al.*, 1989; Stein-Behrens *et al.*, 1995) atrophy, and reduced branching of subfield CA3 pyramidal cell apical dendrites (Woolley *et al.*, 1990; Watanabe *et al.*, 1992; Magarinos and McEwen, 1995a,b). Furthermore, stress or

high glucocorticoid levels exacerbate hippocampal cell damage induced by a number of different insults, i.e., ischemia (Sapolsky, 1985).

The exact mechanism underlying the toxic effects of glucocorticoids in hippocampal subfield CA3 are not known. There is some indication that part of the deleterious effects of glucocorticoids is due to the disruption of energy availability (Sapolsky, 1986; Kadekaro, *et al.*, 1988; Freo *et al.*, 1992). Another important factor in glucocorticoid-induced toxicity in the hippocampus is the involvement of excitatory amino acid neurotransmitters and calcium. Briefly, glucocorticoids increase excitatory amino acid neurotransmission and they impair the ability of hippocampal neurons to maintain intracellular calcium concentrations (reviewed by Sapolsky, 1994).

Senescence

Senescence is associated with elevated HPA axis activity in rats (reviewed by Sapolsky *et al.*, 1986; Sapolsky, 1992) and humans (Raskind *et al.*, 1994). Aged rats display higher ACTH and/or corticosterone plasma levels, and prolonged corticosterone plasma levels following the removal of the stressor (Sapolsky *et al.*, 1984b; 1985b; Landfield, 1987).

The mechanism underlying the senescence-induced changes in HPA axis activity involves the hippocampus (reviewed by Landfield and Eldridge, 1994). The hippocampus in aged rats display several physiological changes that may influence HPA axis activity. For example, hippocampal corticosteroid receptor binding is decreased in aged

rats (Sapolsky *et al.*, 1983a; Rigter *et al.*, 1984; Reul *et al.*, 1988) and their regulation is altered (Eldridge *et al.*, 1989a,b). The changes in HPA axis activity in senescent rats resemble the changes that occur with hippocampectomy (Fendler *et al.*, 1961; Feldman and Conforti 1976,1980; Kant *et al.*,1984; Sapolsky *et al.*,1984b, 1989; Margarinos *et al.*,1987). An age related loss in hippocampal neurons has also been reported (Coleman *et al.*, 1987; Sapolsky, 1992).

Based on the association between high glucocorticoid levels and hippocampal neuron damage with stress and aging, Sapolsky and colleagues (1986) put forth a glucocorticoid cascade hypothesis of neuronal damage. Briefly, a prolonged exposure to elevated glucocorticoid levels, due to either stress or prolonged excitatory neural inputs into the HPA axis, decreases corticosteroid receptor levels in the hippocampus. The reduced corticosteroid receptor levels attenuate HPA axis feedback, further prolonging the elevated glucocorticoid exposure. Eventually, the glucocorticoids produce toxic effects (discussed above), inducing hippocampal cell loss.

Depression

Altered HPA axis activity is often associated with depression. The abnormalities of the HPA system in depression are manifested as an: 1) increased level of cortisol in the urine (free cortisol), plasma, and cerebral spinal fluid; 2) alterations in cortisol levels during the diurnal rhythm; 3) an attenuation of the CRF-induced release of ACTH; and 4) decreased ability of dexamethasone to suppress cortisol secretion (reviewed by

Murphy 1991a; Checkley *et al.*, 1992). Similar abnormalities are also observed in aged rats (Issa *et al.*, 1990).

It is not known why the HPA axis activity is elevated in depression, or how corticosteroids and depression are linked. However, several lines of evidence implicate corticosteroids in the etiology and treatment of depression (Barden *et al.*, 1995). For example, suppressing hypercortisol secretion has been reported to abate depression in several independent studies (Jeffcote *et al.*, 1979; Kelly *et al.*, 1980; 1983; Nieman *et al.*, 1985; Murphy 1991b; Murphy *et al.*, 1991a,b). Also chronic treatment with antidepressant agents increases MR and GR binding capacity (Reul *et al.*, 1993) and mRNA levels in the rat hippocampus (Brady *et al.*, 1991; Seckl and Fink, 1992; Yau *et al.*, 1995).

Cushing Syndrome and Hypercorticosteroid Secretion

Drugs targeting the HPA axis may be a viable resource for treating pathological conditions associated with hypercorticosteroid secretion. It is well documented that hypersecretion of corticosteroids is associated with prolonged stress, aging, and depression. However, it has been difficult for investigators to show directly that hypercorticosteroid secretion can precipitate these conditions. The best evidence available supporting a direct link between hypercorticosteroid secretion with stress and depression is derived from Cushing's syndrome patients.

One of the clinical features of Cushing's syndrome is a persistent elevation in plasma corticosteroid levels (Cushing, 1932). These patients also display many of the same features characteristic of prolonged stress. For example, cerebral cortical atrophy and hippocampal cell loss are commonly found in the brains of patients with Cushing's syndrome (Jensen *et al.*, 1982; Uno *et al.*, 1989; Starkman *et al.*, 1992). Depression is a clinical symptom in approximately half of the Cushing's syndrome cases (Jeffcoate *et al.*, 1979; Cohen, 1980) and suppressing the hypercorticosteroid secretion in these patients dramatically reduces their depression (Jeffcote *et al.*, 1979; Kelly *et al.*, 1980, 1983; Nieman *et al.*, 1985).

Concluding Remarks

The hippocampus contains the highest density of corticosteroid receptors in the brain, which leads to the suggestion that corticosteroids may have a profound influence on hippocampal signal processing. Previous investigations have demonstrated that corticosteroids modulate several cell membrane electrophysiological characteristics and responses elicited by the activation of several different neurotransmitter receptors on pyramidal cells in the hippocampus (Joëls *et al.*, 1991, Joëls and de Kloet, 1992; Beck *et al.*, 1994; Birnstiel and Beck, 1995; Beck *et al.*, 1996). The mechanism by which corticosteroids modulate signal processing in the hippocampus is not completely resolved. One piece of information that is missing is the effects of corticosteroids on neural activity in all of the different hippocampal regions and subfields. The effects of

corticosteroids on pyramidal cell membrane electrophysiological properties and 5-HT_{1A} receptor signal transduction system are not known in subfield CA3. This is an important point since the neurons in subfield CA3 have a critical role in processing synaptic information based on their unique synaptic organization (Knowles, 1992; Bernard and Wheal, 1994), electrophysiological characteristics (Nunez *et al.*, 1990; Beck *et al.*, 1992; Spruston and Johnston, 1992) and responses elicited by the activation of neurotransmitter receptors (Beck *et al.*, 1992, 1995). Information on the actions of corticosteroids on pyramidal cell membrane electrophysiological properties and the 5-HT_{1A} receptor signal transduction system will contribute to a basic understanding of how corticosteroids alter cell excitability, alter responses elicited by the activation of G protein-linked neurotransmitter receptors, and will help to elucidate the role of corticosteroid receptors in information processing in the hippocampus.

CHAPTER III

CORTICOSTEROIDS ALTER PYRAMIDAL CELL ELECTROPHYSIOLOGICAL CHARACTERISTICS IN HIPPOCAMPAL SUBFIELD CA3

Abstract

The hippocampus contains the highest density of MR and GR in the central nervous system. The modulation of neuron excitability by corticosteroids in hippocampal subfield CA1 is well documented. However, it is not known if corticosteroids produce different effects across the various hippocampal subfields. Therefore, we used intracellular recording techniques to examine the actions of chronic corticosteroid treatment (2 weeks) on the electrophysiological properties of rat hippocampal subfield CA3 pyramidal cells. The treatment groups used in this investigation were, adrenalectomy (ADX), selective MR activation with aldosterone (ALD), MR and GR activation with high levels of corticosterone (HCT), and SHAM.

Corticosteroid treatment altered the percentage of nonburst and burst firing neurons. The largest differences were observed with ADX animals where the percentage of nonbursting cells was 74% compared to 42% and 41% in ALD and SHAM animals. Corticosteroids did not alter the membrane input resistance,

resting potential, or time constant. Corticosteroids also had no effect on the slow- or fast-afterhyperpolarizing potential amplitude or duration. The action potential duration was longer in cells from ADX animals compared to cells from HCT and ALD animals. Based on our results, we conclude that corticosteroids altered the firing mode and decreased the action potential duration in subfield CA3 pyramidal cells. Both of these findings are novel results which are distinct from those previously reported for subfield CA1, suggesting that corticosteroids have different effects across hippocampal subfields.

Introduction

Corticosteroids (glucocorticoids and mineralocorticoids) are steroid hormones that maintain homeostasis by influencing energy production and electrolyte balance (Henkin, 1970; Munck *et al.*, 1984, de Kloet, 1991). Corticosteroids are synthesized in the adrenal cortex and their release regulated by the hypothalamic-pituitary-adrenal (HPA) axis. Corticosteroids regulate gene expression through two receptor subtypes: MR (or type I) and GR (or type II) (Joëls *et al.*, 1994b). MR has a high affinity for corticosterone ($K_D = 0.5 - 0.7 \text{ nM}$) and is 70-80% occupied at basal physiological corticosterone plasma levels (Krozowski and Funder, 1983; Reul and de Kloet, 1985; Reul *et al.*, 1987a,b). GR has a lower affinity for corticosterone, $K_D = 2.5 - 5 \text{ nM}$, and its occupancy changes from 15% at basal to 90% at peak and stress circulating corticosterone levels (Reul and de Kloet, 1985; Reul *et al.*, 1987a,b).

The hippocampus contains the highest concentration of corticosteroid receptors in the CNS (McEwen *et al.*, 1968; Warembourg, 1975; Sapolsky *et al.*, 1983b; Sarrieau *et al.*, 1984; Reul and de Kloet, 1985, 1986; Magarinos *et al.*, 1989). Corticosteroids have a profound influence on cells in the hippocampus (de Kloet *et al.*, 1993; McEwen *et al.*, 1993). The effects of MR and GR activation on pyramidal cell excitability and ionic currents are well documented for subfield CA1. Generally, MR activation increases CA1 pyramidal cell excitability while GR activation decreases cell excitability (Beck *et al.*, 1994; Joëls and de Kloet, 1994).

It is not known if corticosteroids have a different effect on neuron electrophysiological properties in subfield CA3. This is an important issue since the hippocampus processes information along a trisynaptic lamellar pathway (Andersen *et al.*, 1971b; Andersen, 1975) with the pyramidal cells in subfield CA1 receiving their inputs via Schaffer collaterals from the pyramidal cells in subfield CA3. It is important to determine how corticosteroids modulate synaptic transmission along this pathway. Neurons in each subfield have a distinct role in processing synaptic transmission based on their different local interneuron circuits (Knowles, 1992), electrophysiological characteristics (Brown *et al.*, 1981; Nunez *et al.*, 1990; Beck *et al.*, 1992; Spruston and Johnston, 1992) and neurotransmitter-mediated responses (Beck *et al.*, 1992, 1995). Furthermore, the MR/GR ratio is greater in subfield CA1 (6.5:1) compared to CA3 (1:1) as determined by a receptor binding investigation (Reul and de Kloet, 1985).

We used intracellular recording techniques to examine the effects of chronic corticosteroid treatment on the electrophysiological properties of pyramidal cells in hippocampal subfield CA3. Our hypothesis is that corticosteroids will produce a different modulatory action in subfield CA3 neurons as compared to those previously reported for subfield CA1. These results will contribute to a basic understanding of how corticosteroids alter cell excitability and will help to elucidate the role of corticosteroid receptors in information processing in the hippocampus.

Materials and Methods

Materials

Corticosterone pellets were purchased from Innovative Research of America (Sarasota, FL). Aldosterone was purchased from Steraloids Inc. (Wilton, NH). Osmotic minipumps were purchased from Alzet Cooperation (Palo Alto, CA). All other chemicals were obtained from standard commercial sources.

Animals

Four different treatment groups were used for the experiments in this investigation (**Table 1**). The adrenalectomy was performed as described previously (Beck *et al.*, 1994, 1996; Birnstiel and Beck, 1995). Male Sprague-Dawley rats (Harlan) 75-100g were used for all treatment groups. Bilateral adrenalectomies were performed on all treatment groups, except the SHAM group, to remove circulating corticosteroids.

Table 1.-- Treatment groups

Treatment	Surgery	Implant	ACSF
SHAM	Intact	Nothing	1 nM corticosterone
ADX	Adrenalectomy	Nothing	no steroid
ALD	Adrenalectomy	Aldosterone (10 μ g/h minipump)	3 nM aldosterone
HCT	Adrenalectomy	200 to 300 mg corticosterone	100 nM corticosterone

Animals were anesthetized with ether. A small incision was made into the abdominal cavity, just below the rib cage, and the adrenal glands carefully removed. The muscle wall was then sutured and the skin closed using wound clips. The ADX group received no further treatment. The ALD group had an osmotic minipump containing aldosterone (Alzet model 2002) implanted subcutaneously at the time of adrenalectomy, to selectively activate MR. The minipump delivered 10 μ g/h aldosterone dissolved in propylene glycol. MR and GR were activated in another group of animals (HCT) by subcutaneously implanting 200-300 mg corticosterone pellets, 2 to 3 week release, in the back of the neck at the time of adrenalectomy. The SHAM group of animals was produced by visualizing the adrenal glands but leaving them intact. After surgery the animals were maintained on a standard twelve hour light/dark cycle and rat chow, *ad libitum*. SHAM animals were given standard drinking water while the ADX, ALD, and HCT animals were given 0.9 % NaCl drinking water

ad libitum. At the end of 13 - 15 days, the animals were sacrificed in the morning and hippocampal slices immediately prepared for electrophysiological recording. At the time of sacrifice, trunk blood was collected to determine the plasma corticosterone levels by radioimmune assay (Burgess and Handa, 1992).

Hippocampal Slice Preparation

Hippocampal slices were prepared for electrophysiological recording as previously described (Okuhara and Beck, 1994). Rats were sacrificed by decapitation and the brain rapidly removed and placed in ice cold artificial cerebrospinal fluid (ACSF) containing in mM: NaCl 125, KCl 3, NaH₂PO₄ 1.25, MgSO₄ 2, CaCl₂ 2.5, dextrose 10, and NaHCO₃ 28. The ACSF was also supplemented with steroids, as outlined in **Table 1**, to maintain the treatment paradigm. We previously reported that steroids must be present in the ACSF to preserve the corticosteroid-induced effects on neuron cell properties (Beck *et al.*, 1994). The hippocampus was dissected free and the dorsal section cut in 500 - 550 μ m sections on a vibratome. The hippocampal slices were then placed in a holding vial containing ACSF bubbled with 95% O₂-5% CO₂ at room temperature. The slices remained in the holding vial for at least one hour after dissection before being transferred to the recording chamber. In the recording chamber, the slice was stabilized between two nylon nets and continuously perfused with ACSF bubbled with 95% O₂-5% CO₂ at a rate of 2-3 ml/min, at 31-32°C.

Intracellular Recording

Intracellular recordings were made as previously described (Okuhara and Beck, 1994). Electrodes were pulled from borosilicate capillary tubing on a Brown and Flaming electrode puller (Sutter Instruments) to a resistance of 30-35 M Ω (2 M KCl). Pyramidal cells were impaled with brief ejections of positive current through the electrode. The impaled cells were sealed by applying 1 nA hyperpolarizing current. Electrical signals were collected and amplified using an Axoclamp 2A and Cyberamp 320 amplifier (Axon Instruments, Foster City, CA) and recorded on a Gould Series 3200 chart recorder (Gould Electronics, Valley View, OH). Data were collected on-line with pCLAMP software (Axon Instruments).

Statistical Analysis

Statistical comparisons were performed using analysis of variance (ANOVA). The Student-Newman-Keuls method was used for post-hoc tests. A chi-square test was used to determine if the percentage of bursting and nonbursting cells was different with corticosterone treatment. All values are reported as mean \pm S.E.M. A $p < 0.05$ was considered significant.

Results

Corticosterone Plasma Levels

SHAM corticosterone plasma levels ranged from 0 - 4.13 $\mu\text{g}/\text{dl}$ ($1.23 \pm 0.24 \mu\text{g}/\text{dl}$,

n = 22). ADX corticosterone plasma levels ranged from 0 - 0.5 $\mu\text{g}/\text{dl}$ (0.21 ± 0.05 $\mu\text{g}/\text{dl}$, n = 20). ALD corticosterone plasma levels ranged from 0 - 0.6 $\mu\text{g}/\text{dl}$ (0.12 ± 0.05 $\mu\text{g}/\text{dl}$, n = 18). The lower and upper limits of the corticosterone radioimmune assay were 0.05 and 50 $\mu\text{g}/\text{dl}$ respectively. Adrenalectomies that produced corticosterone concentrations ≤ 0.6 $\mu\text{g}/\text{dl}$ were considered successful. Two SHAM, 12 ADX, and 13 ALD animals had corticosterone levels less than 0.05 $\mu\text{g}/\text{dl}$. The concentration of aldosterone used in our experiments was based on an investigation by Kuroda *et al.*, (1994). The ALD treatment decreased MR binding by 61% (n = 5 animals) in the cytoplasm (data not shown) as determined using a homogenate binding assay. HCT plasma concentrations greater than 20 $\mu\text{g}/\text{dl}$ were considered successful. HCT corticosterone plasma levels ranged from 25 to > 50 $\mu\text{g}/\text{dl}$ (39.96 ± 2.90 $\mu\text{g}/\text{dl}$, n = 11).

Passive Membrane Properties

The analysis of cell characteristics was as described previously (Beck *et al.*, 1994). Two different firing modes have been described for neurons in subfield CA3 (Wong and Prince, 1978, 1981; Masukawa *et al.*, 1982; Bilkey and Schwartzkroin, 1990). One type of firing mode is a regular spiking pattern of action potentials in response to a long depolarizing pulse (nonbursting cells) while the other mode is a cluster of spikes which reside on a slow depolarizing potential (bursting cells). We also observed burst

and nonburst firing in the present investigation (**Figure 7**). A chi-square analysis indicated that the percentage of bursting and nonbursting cell types was dependent on the type of corticosteroid treatment (**Table 2**). Since it is not known if corticosteroids have different effects on nonbursting and bursting cell types, the pyramidal cell characteristics data were divided into nonbursting and bursting cell types. The data were first analyzed using a two-way ANOVA with treatment as one variable and cell type as the other variable. If there were no significant effects between cell type, the data were then analyzed using one-way ANOVA, collapsing across cell type and grouping according to treatment only.

The membrane potential was read directly from the amplifier display. Corrections for the input offset were done after the electrode was withdrawn from the cell. The membrane input resistance and membrane time constant were calculated from current-voltage plots. The current-voltage plot data were generated by injecting 300 ms pulses of -900 to 0 pA in 100 pA increments into the cell while recording the cell's membrane potential. The membrane input resistance was calculated from the slope of the linear portion of the current-voltage plots. The membrane time constant corresponded to the length of time required for the membrane potential to reach 63% of its final value during a 300 ms pulse of -100 pA. There were no differences in resting membrane potential, input resistance, or membrane time constant between either cell type or corticosteroid treatment (**Table 3**).

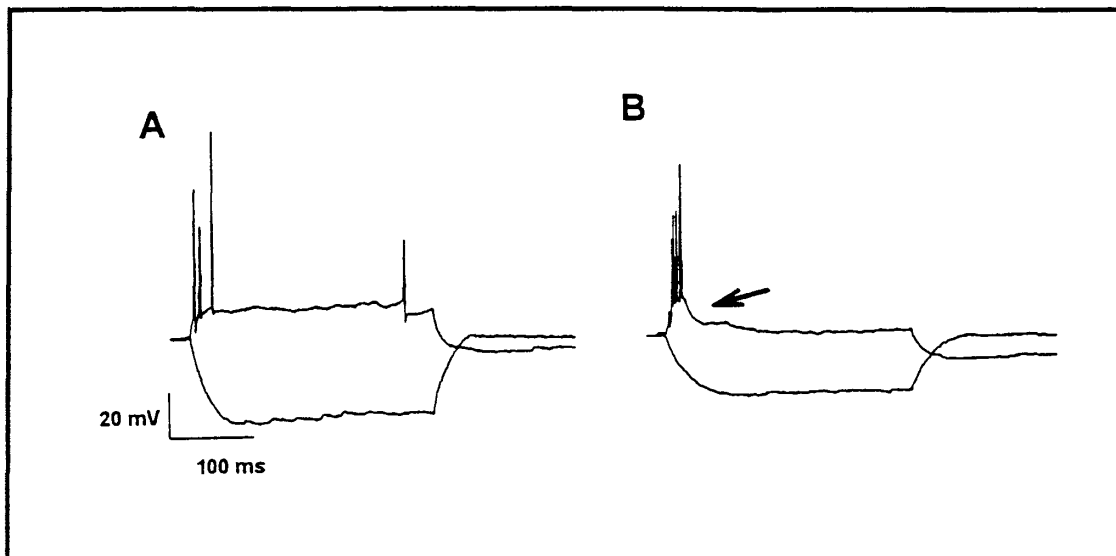

Figure 7. Membrane potential changes in a nonbursting and burst firing cell.

A: Nonbursting cell. **B:** Bursting cell. The cells received an injection of -700 and 400 pA current pulses, 300 ms in duration. Plots were generated from digitized data, therefore, action potentials appear truncated. Notice the slow depolarizing envelope in the bursting cell (arrow).

Table 2.--Number of nonbursting and bursting cells recorded from the different corticosterone treatment groups

	SHAM	ADX	ALD	HCT
nonbursting	13	29	11	16
bursting	19	10	15	10
% nonbursting	41	74	42	62

Proportion of nonbursting and bursting cells are different between treatment groups.

$$\chi^2 = 9.592, \text{ d.f.} = 3, P = 0.022.$$

Table 3.--The effects of corticosteroids on passive membrane electrophysiological properties

Treatment & cell type		RMP (mV)	Resistance (M Ω)	Tau (ms)
SHAM	NB	68.4 \pm 1.4 (13)	50.1 \pm 2.8 (13)	49.3 \pm 4.2 (13)
	B	72.0 \pm 1.2 (19)	51.0 \pm 1.9 (19)	49.3 \pm 3.6 (19)
ADX	NB	68.8 \pm 0.9 (29)	51.6 \pm 2.3 (29)	42.8 \pm 2.4 (29)
	B	69.3 \pm 1.4 (10)	48.6 \pm 3.0 (10)	53.4 \pm 5.7 (10)
ALD	NB	68.4 \pm 1.8 (11)	45.2 \pm 2.3 (11)	43.8 \pm 5.4 (11)
	B	71.7 \pm 1.2 (15)	49.8 \pm 2.9 (15)	48.1 \pm 6.0 (15)
HCT	NB	68.6 \pm 1.5 (16)	54.7 \pm 1.7 (16)	44.5 \pm 4.3 (15)
	B	68.6 \pm 2.1 (10)	47.7 \pm 4.8 (9)	55.1 \pm 6.1 (9)

All values are reported as mean \pm SEM (n)

Cell type NB, nonbursting; B, bursting

Action Potential and fAHP Properties

Table 4 summarizes the effects of corticosteroids on action potential and fAHP properties. Action potentials were generated with short 2-4 ms depolarizing pulses. The action potential threshold was the membrane potential value just before the action potential spike began to rise. The action potential threshold was used as the baseline value to calculate its height and baseline duration. The action potential height was measured from baseline to the peak of the spike. The action potential half-width was the width of the spike at 50% of its peak amplitude. The action potential baseline duration was the spike width along its baseline. fAHP's were generated with 20 ms pulses of enough current (300-600 pA) to generate a single action potential. The fAHP amplitude was measured from threshold to the peak hyperpolarizing amplitude which occurred 1-4 ms after the end of the spike. The fAHP $t_{1/2}$ corresponds to the amount of time for the fAHP to decrease from its peak amplitude to one-half of its value.

Based on a two-way ANOVA examination, neither corticosteroid treatment nor cell type had an effect on the action potential threshold. The action potential peak amplitude was smaller in bursting cells (80.3 ± 0.7 mV, $n = 52$.) compared to nonbursting cells (82.7 ± 0.6 mV, $n = 69$) ($F = 6.252$; d.f. = 1, 113; $P = 0.014$). However, corticosteroid treatment had no effect on the action potential peak amplitude ($F = 2.021$; d.f. = 3, 113; $P = 0.115$). Corticosteroid treatment did alter the action potential duration. The action potential half- and baseline widths were wider in cells

from ADX animals compared to cells from ALD and HCT animals (**Figure 8**). The action potential half-width was also wider in cells from SHAM animals compared to ALD.

sAHP and Accommodation

The effects of corticosteroids on sAHP and accommodation properties are summarized in **Table 5**. sAHP's were generated by injecting 300-500 ms pulses of 800-1200 pA to elicit a train of sodium action potentials. A train of sodium action potentials usually generate two types of afterhyperpolarizing potentials, a medium-afterhyperpolarizing potential followed by a sAHP (Madison and Nicoll, 1984). Therefore, the sAHP amplitude was measured after the medium-afterhyperpolarizing potential ended (approximately 100 to 250 ms after the current pulse terminated). The sAHP $t_{1/2}$ corresponds to the amount of time for the sAHP to decrease from its peak amplitude to one-half of its baseline value. Spike accommodation corresponds to the number of action potentials that occurred during a 300 ms depolarizing pulse.

Two-way ANOVA analysis of the data indicated that the sAHP amplitude was smaller in nonbursting cells (10.8 ± 0.5 mV, $n = 65$) compared to bursting cells (12.4 ± 0.5 mV, $n = 38$) ($F = 5.822$; d.f. = 1, 111; $P = 0.017$). Consistent with the larger sAHP in bursting cells, accommodation was also greater in bursting cells (4.5 ± 0.47 spikes, $n = 53$) compared to nonbursting cells (5.7 ± 0.3 , $n = 64$) ($F = 5.743$; d.f. = 1, 110;

Table 4.--The effect of corticosteroids on action potential and fAHP properties.

Treatment & cell type	Action Potential				fAHP	
	Threshold (mV)	Amplitude (mV)	Half-width ^a (μ s)	Baseline width ^b (ms)	Amplitude (mV)	t _{1/2} (ms)
SHAM NB	50.9 \pm 0.6 (13)	82.2 \pm 1.4 (13)	963 \pm 40 (13)	1.67 \pm 0.06 (13)	7.8 \pm 0.4 (13)	3.3 \pm 0.3 (13)
B	50.8 \pm 0.4 (19)	79.7 \pm 0.8 (19)	926 \pm 20 (19)	1.60 \pm 0.04 (19)	7.7 \pm 0.4 (17)	3.0 \pm 0.2 (17)
ADX NB	51.4 \pm 0.5 (29)	84.0 \pm 1.1 (29)	975 \pm 20 (28)	1.68 \pm 0.04 (28)	7.8 \pm 0.6 (26)	2.9 \pm 0.2 (26)
B	51.7 \pm 0.7 (10)	82.5 \pm 0.5 (10)	940 \pm 30 (10)	1.64 \pm 0.07 (10)	6.7 \pm 0.5 (9)	2.4 \pm 0.2 (9)
ALD NB	51.9 \pm 0.7 (11)	83.5 \pm 1.3 (11)	877 \pm 20 (11)	1.52 \pm 0.04 (11)	7.2 \pm 0.8 (11)	2.7 \pm 0.2 (11)
B	50.1 \pm 0.5 (14)	79.9 \pm 1.4 (14)	862 \pm 20 (14)	1.49 \pm 0.05 (14)	7.6 \pm 0.5 (15)	2.9 \pm 0.3 (15)
HCT NB	52.0 \pm 0.7 (16)	81.0 \pm 1.3 (16)	896 \pm 20 (16)	1.53 \pm 0.04 (16)	9.0 \pm 0.6 (14)	2.8 \pm 0.2 (14)
B	51.7 \pm 0.6 (9)	79.2 \pm 1.4 (9)	896 \pm 30 (9)	1.58 \pm 0.06 (9)	8.4 \pm 0.7 (10)	3.1 \pm 0.4 (10)

All values are reported as mean \pm SEM (n)

Cell types NB, nonbursting; B, bursting

^a ADX (966 \pm 20 μ s, n = 38) different from ALD (869 \pm 10 μ s, n = 25) and HCT (896 \pm 20 μ s, n = 25)
 SHAM (941 \pm 20 μ s, n = 32) different from ALD. One-way ANOVA F = 4.419; d.f. = 3, 113; P = 0.006.
 Student-Newman-Keuls p < 0.05

^b ADX (1.67 \pm 0.04 ms, n = 38) different from ALD (1.51 \pm 0.03 ms, n = 25) and HCT (1.55 \pm 0.03 ms, n = 15)

$P = 0.018$). Corticosteroid treatment had no effect on the sAHP amplitude ($F = 2.096$, d.f. = 3, 111; $P = 0.105$) or accommodation properties ($F = 0.04$; d.f. = 3, 110; $P = 0.989$).

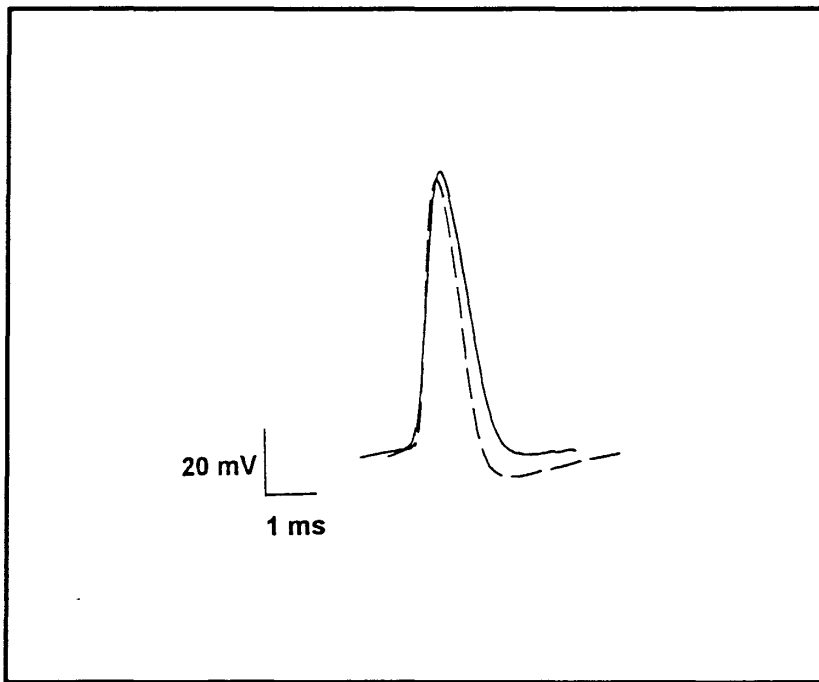

Figure 8. Superimposed action potentials in a cell from an ADX and HCT animal. Each trace represents an average of five action potentials in a cell from either an ADX (solid line) or HCT (broken line) treated animal.

Table 5.--The effect of corticosteroids on sAHP and accommodation properties

Treatment & cell type		sAHP Amplitude (mV)	sAHP $t_{1/2}$ (ms)	Accommodation (no. of spikes)
SHAM	NB	11.8 ± 0.9 (13)	1001 ± 86 (6)	5.2 ± 0.6 (13)
	B	13.7 ± 0.8 (19)	945 ± 55 (11)	5.1 ± 0.4 (19)
ADX	NB	11.7 ± 0.6 (28)	1126 ± 84 (19)	6.4 ± 0.7 (26)
	B	11.3 ± 1.1 (10)	961 ± 65 (9)	4.0 ± 0.7 (9)
ALD	NB	9.9 ± 1.2 (11)	1186 ± 238 (10)	4.9 ± 0.5 (11)
	B	13.8 ± 1.1 (15)	1022 ± 55 (12)	4.1 ± 0.5 (15)
HCT	NB	9.7 ± 1.0 (13)	853 ± 106 (11)	6.3 ± 0.9 (14)
	B	10.9 ± 1.1 (9)	1052 ± 58 (6)	3.9 ± 0.5 (10)

Discussion

We examined the effects of corticosteroids on pyramidal cell electrical properties in subfield CA3. The primary finding was that the percentage of nonbursting and bursting cell types was dependent upon corticosterone treatment. Therefore, we analyzed the cell characteristics according to treatment and cell type. There were several cell characteristics that were different between nonbursting and bursting cell types. Nonbursting cells had a larger action potential peak amplitude, less accommodation, and a smaller sAHP amplitude compared to bursting cells. However, corticosteroid treatment had no effect on these cell characteristics. Corticosteroids also had no effect on the passive membrane properties (membrane potential, input resistance, and time constant), fAHP amplitude and duration. Corticosteroids did

increase the action potential duration in cells from ADX animals compared to ALD and HCT. The action potential duration was also longer in cells from SHAM animals compared to ALD.

Percentage of Nonbursting and Bursting Cells

The pyramidal cells in subfield CA3 are divided into bursting and nonbursting cell types, depending on their firing pattern. Bursting cells produce a burst of 3-5 action potentials on top of a slow depolarizing envelope (Wong and Prince, 1978, 1981; Masukawa *et al.*, 1982; Bilkey and Schwartzkroin, 1990). The percentage of nonbursting cells we observed in subfield CA3 in SHAM and ALD animals (41% - 42%) is similar to the values reported for naive animals (40% - 41%) (Masukawa *et al.*, 1982; Bilkey and Schwartzkroin, 1990). ADX produced the largest shift in the percentage of nonbursting cells, increasing the amount of nonbursting cells to 74%.

The effect of corticosteroids on the ratio of burst and nonbursting cells do not appear to be secondary to changes in cell viability. The cell resting membrane potential, resistance, and time constant were not altered by corticosterone treatment, and were comparable to those reported in naive animals (Beck *et al.*, 1992).

Adrenalectomy has been reported to induce granule cell degeneration in the dentate gyrus. While the most severe cell loss occurs between 4 or more months after adrenalectomy (Sloviter *et al.*, 1989; 1993; Roy *et al.*, 1990; McNeil *et al.*, 1991; Sapolsky *et al.*, 1991; Jaarsma *et al.*, 1992), granule cell degeneration was also

reported to occur between 1 to 3 weeks after adrenalectomy (Gould *et al.*, 1990; Sloviter *et al.*, 1993). Granule cells form synapses with subfield CA3 pyramidal cells and the loss of granule cells induced by adrenalectomy may account for the large shift in the percentage of nonbursting cells. However, there is no evidence to support that the degenerating granule neurons are altering the physiological or biochemical properties of CA3 pyramidal cells.

Based on several lines of evidence it is unlikely that the large shift in percentage on nonbursting cells observed with ADX treatment is due to the loss of dentate granule cells. First, Sloviter *et al.* (1993, 1995) report a large variation in granule cell degeneration at any given time point and the percentage of degenerating granule cells following 14 days of adrenalectomy was not reported. The large variation in degenerating granule cells may have a significant effect on the results if only a small number of animals were used. However, we examined the effects of ADX in twenty rats, a sample size comparable if not greater than that used by Sloviter *et al.*, (1993). Second, it is unlikely that the massive loss of granule cells only influenced the firing pattern and action potential duration of CA3 neurons. Such a huge loss in synaptic inputs should attenuate numerous electrical membrane properties. Finally, it was reported that within one week of adrenalectomy both cell loss and mitosis was induced (Cameron and Gould, 1996), therefore, the overall synaptic integrity between the dentate and subfield CA3 may not be altered with adrenalectomy. While the loss of

granule cells following 14 days of adrenalectomy is important and may have a significant effect on neuronal signaling between the dentate and subfield CA3, it does not readily explain or diminish the significance of the large difference in the percentage of nonbursting cells observed in ADX treated animals.

A possible explanation for the increased number of nonbursting cells is that corticosteroids modulate the ionic current that influences the bursting firing mode. The exact nature of burst firing is not known. Early investigations reported that burst firing is due to a slow Ca^{2+} current (Wong and Prince, 1978, 1981), however, there is also evidence supporting the role of Na^+ current in burst firing, possibly a persistent Na^+ current (Konnerth *et al.*, 1986; French *et al.*, 1990; Azouz *et al.*, 1996; Jensen *et al.*, 1996). The ionic conductances underlying pyramidal cell burst firing may be different across hippocampal subfields (Azouz *et al.*, 1996; Jensen *et al.*, 1996). Burst firing in subfield CA3 may depend on both Na^+ and Ca^{2+} currents (Wong and Prince, 1978, 1981; Konnerth *et al.*, 1986), whereas, burst firing in subfield CA1 cells depend upon Na^+ currents only (Azouz *et al.*, 1996; Jensen *et al.*, 1996). Since corticosterone treatment influences burst firing in subfield CA3 neurons, it may be possible to determine the exact ion currents and channels underlying burst firing in subfield CA3 cells by comparing the isolated ion currents in cells from adrenalectomized and corticosterone treated animals.

The effects of corticosteroids on isolated Ca^{2+} and Na^+ currents in subfield CA3 are not known. The action of corticosteroids on Ca^{2+} currents in subfield CA1 have been determined but the results are not straight forward. Adrenalectomy decreased the Ca^{2+} action potential area (Kerr *et al.*, 1989; 1992) but increased Ca^{2+} currents (Karst and Joëls, 1994). Corticosteroids also modulate Ca^{2+} homeostasis (Elliott and Sapolsky, 1993), which in turn, may influence the Ca^{2+} driving potential and/or ion channels. Other factors contribute to burst and nonburst firing and include the relative densities and distribution of Ca^{2+} -independent K^+ channels along a neuron (Migliore *et al.*, 1995) and neuron morphology (Bilkey and Schwartzkroin, 1990).

Passive Membrane and Action Potential Properties

The membrane input resistance and time constant are determined by passive and voltage-dependent ion channels that normally function near the cell's resting membrane potential (Rall, 1977). The membrane input resistance and time constant determine the decay of synaptic potentials in the dendrites and soma, therefore, influencing the integration of postsynaptic potentials (Rall, 1977). Corticosteroids did not alter the resting membrane potential, input resistance, or time constant in subfield CA3 pyramidal neurons. In contrast, the membrane input resistance and time constant in subfield CA1 pyramidal cells are altered by corticosteroids. The changes in CA1 cells may be due to alterations in I_Q (Karst *et al.*, 1993; Beck *et al.*, 1994), which is less

prominent in CA3 cells (Spruston and Johnston 1992). Therefore, corticosteroids may alter the integration of postsynaptic potentials in CA1 but not in CA3 cells.

The decrease in action potential half- and baseline width in cells from ALD and HCT animals suggest that corticosteroids may play a role in the shaping of action potentials. Furthermore, corticosteroids appear to have different effects on action potential characteristics in cells from subfields CA1 and CA3. Chronic low (basal) levels of corticosterone increased action potential height and duration in pyramidal cells from subfield CA1 and decreased the fAHP amplitude (Beck *et al.*, 1994) when compared to cells from adrenalectomized animals. In the present study we observed a decrease in the action potential duration and no change in the action potential height and fAHP amplitude in cells from ALD animals when compared to ADX.

The broader action potential duration in cells from SHAM and ADX animals may be physiologically important. Wheeler *et al.*, (1996) reported that increasing the action potential duration leads to an increase in Ca^{2+} influx at the presynaptic terminal and enhances synaptic strength. Therefore, MR activation could conceivably have different effects on Ca^{2+} influx at the axon terminals arising from subfields CA1 and CA3. The narrowing of action potentials may result from changes in any of the K^+ and Ca^{2+} ion currents which shape the action potential (Rutecki, 1992). Further experiments are required to determine which current(s) are altered by corticosteroids.

sAHP and Accommodation

The sAHP and accommodation characteristics in cells from subfield CA1 were the first electrophysiological membrane characteristics identified that were altered by corticosteroids (Joëls and de Kloet, 1989; Kerr *et al.*, 1989; Joëls and de Kloet, 1990). Both of these properties rely on a Ca^{2+} -dependent K^+ current (Madison and Nicoll, 1984; Lancaster and Nicoll, 1987). In subfield CA1, short term and chronic MR activation decreased spike accommodation and sAHP amplitude (Kerr *et al.*, 1989; Joëls and de Kloet, 1990; Beck *et al.*, 1994).

Unlike the cells in subfield CA1, corticosteroids did not alter the sAHP or accommodation in subfield CA3 neurons. This is an interesting result because both the sAHP and burst firing are triggered by Ca^{2+} currents (Wong and Prince, 1978, 1981; Schwartzkroin and Stafstrom, 1980; Konnerth *et al.*, 1986; Sah and Isaacson, 1995), yet corticosteroids only appear to alter the cell's firing mode. The relationship between burst firing and sAHPs is not well known. There are several lines of evidence suggesting that burst firing and sAHP may be independent properties. The channels underlying burst firing and sAHP's may be located in different areas of the neurons (soma versus dendrites) (Wong *et al.* 1979; Bernardo *et al.*, 1982; Wong and Stewart *et al.*, 1992; Sah and Bekkers, 1996). In subfield CA1, the ionic currents mediating the sAHP and burst firing appear to be separate (Azouz *et al.*, 1996). Finally, in subfield CA3, both Na^+ and Ca^{2+} currents influence burst firing (Wong and Prince, 1978, 1981;

Konnerth *et al.*, 1986). Under our experimental conditions, it was not possible to determine the nature of the current(s) that shifted the fraction of nonbursting and bursting cells.

In conclusion, corticosteroids have numerous effects on neurons located in the hippocampus. Corticosteroids modulate neuron electrophysiological properties (Beck *et al.*, 1994; Joëls and de Kloet, 1994; Joëls *et al.*, 1994a, 1994b), morphology (Woolley *et al.*, 1990; Gould *et al.*, 1991; Watanabe *et al.*, 1992; Magarinos and McEwen, 1995a, 1995b) and neurotransmitter receptor-mediated responses in the hippocampus (Joëls and de Kloet, 1994; Birnstiel and Beck, 1995; Beck *et al.*, 1996). Corticosteroids may alter signal processing in the hippocampus through a complex mechanism, producing different effects in each area of the trisynaptic circuitry (dentate-CA3-CA1). For example, corticosteroids selectively alter dendritic morphology within subfield CA3 (Woolley *et al.*, 1990; Watanabe *et al.*, 1992; Magarinos and McEwen, 1995a,b). Corticosteroids also have different effects on the neuron's electrophysiological properties in subfields CA1 and CA3. This distinct role of corticosteroid modulatory actions among the different hippocampal subfields may be very important in signal processing in the hippocampus.

CHAPTER IV

CORTICOSTEROIDS ALTER 5-HT_{1A} SIGNAL TRANSDUCTION SYSTEM IN HIPPOCAMPAL SUBFIELD CA3 PYRAMIDAL CELLS

Abstract

Corticosteroids influence neuron activity in the hippocampus through the activation of MR and GR receptors. For example, corticosteroids modulate the responses elicited by the activation of several different neurotransmitter receptors on hippocampal pyramidal cells. However, the effects of corticosteroids on the 5-HT_{1A} receptor signal transduction system (receptor-G protein-potassium channel) in subfield CA3 are not completely known. Therefore, we used single-electrode voltage clamp techniques to examine the actions of chronic corticosteroid treatment on the 5-HT_{1A} signal transduction system in rat hippocampal subfield CA3 pyramidal cells. The treatment groups used in this investigation were: ADX, ALD, HCT, and SHAM.

Corticosteroids altered the 5-HT concentration-response curve characteristics for the 5-HT_{1A} receptor. The EC₅₀ value was smaller in cells from ADX compared to the other treatment groups. The E_{max} value was smaller in cells from HCT compared to SHAM and ADX animals. G protein function was also altered by corticosterone

treatment. Less current was elicited by GTP γ S in cells from HCT compared to the other treatment groups and in cells from SHAM compared to ADX animals.

Corticosteroid treatment did not alter the current-voltage relationship or the reversal potential of the potassium current linked to the 5-HT_{1A} receptor. Based on these new findings we conclude that corticosteroids alter the 5-HT_{1A} receptor mediated-response in hippocampal subfield CA3 neurons. Furthermore, corticosteroids alter the 5-HT_{1A} signal transduction system at site(s) downstream of the receptor.

Introduction

Activation of corticosteroid receptors in the hippocampus influences hippocampus-related behaviors (de Kloet *et al.*, 1993) and modulates HPA axis activity (Jacobson and Sapolsky, 1991). Corticosteroid hormones (glucocorticoids and mineralocorticoids) regulate gene expression through the interaction with two receptor subtypes: MR and GR (Joëls *et al.*, 1994b). MR and GR have a 5-10 fold difference in their affinity for the rat corticosteroid hormone corticosterone. MR has a high affinity for corticosterone and is 70-80% occupied at basal corticosterone plasma levels (Krozowski and Funder, 1983; Reul and de Kloet, 1985; Reul *et al.*, 1987a,b). GR has a lower affinity for corticosterone and its occupancy changes from 15% at basal to 90% at peak circadian or stress-induced circulating corticosterone levels (Reul and de Kloet, 1985; Reul *et al.*, 1987a,b).

One way corticosteroids alter neural activity in the hippocampus is by modulating the responses elicited by the activation of neurotransmitter receptors (Joëls and de Kloet, 1994; McEwen, 1996), including the 5-HT_{1A} receptor (Joëls and de Kloet, 1994; Beck *et al.*, 1996). The 5-HT_{1A} receptor is a G protein-coupled receptor. Activation of the 5-HT_{1A} receptor in the hippocampus increases an inward rectifying potassium current linked to a PTX sensitive G protein (Andrade *et al.*, 1986; Andrade and Nicoll, 1987; Colino and Halliwell, 1987; Beck 1989; Beck and Choi, 1991; Okuhara and Beck, 1994). Corticosteroids alter the 5-HT_{1A} receptor-mediated responses in hippocampal subfield CA1 (Joëls *et al.*, 1991, Joëls and de Kloet, 1992; Beck *et al.*, 1996). However, the effects of corticosteroids on the 5-HT_{1A} receptor-mediated responses in subfield CA3 are not known.

Previous studies have examined the effects of corticosteroids on the number of 5-HT_{1A} binding sites and mRNA levels (Chaouloff, 1995). Corticosteroids appear to alter 5-HT_{1A} receptor binding sites in subfield CA3, but not in subfield CA1 (Mendelson and McEwen, 1992a,b; Kuroda *et al.*, 1994). Recently, we reported that chronic exposure to high levels of corticosteroids increased the protein levels of G_s, G_{i1and 2}, and G_o α -subunits in the hippocampus (Okuhara *et al.*, 1996a). However, the actions of corticosteroids on G protein function in the individual hippocampal subfields and on G protein-evoked currents are not known.

In the present study, we examined the effects of chronic corticosteroid treatment on different components of the 5-HT_{1A} signal transduction system in hippocampal subfield CA3 pyramidal cells. Single-electrode voltage clamp techniques were used in the brain slice preparation. We hypothesized that chronic corticosteroid treatment would alter the 5-HT_{1A} receptor signal transduction system in subfield CA3. The results from these experiments will contribute to a basic understanding of how corticosteroids alter responses elicited by the activation of G protein-linked neurotransmitter receptors and help to elucidate the role of corticosteroids in hippocampus-related behaviors and HPA axis feedback.

Materials and Methods

Materials

Corticosterone pellets were purchased from Innovative Research of America (Sarasota, FL). Aldosterone was purchased from Steraloids Inc. (Wilton, NH). Osmotic minipumps were purchased from Alza Cooperation (Palo Alto, CA). Tetrodotoxin and 5-HT hydrochloride were purchased from Sigma Chemicals (St. Louis, MO). GTP γ S was purchased from Boehringer Mannheim (Indianapolis, IN). All other chemicals were obtained from standard commercial sources.

Animals

Four different treatment groups were used for the experiments in this investigation (Table 1, pg. 64). The adrenalectomy was performed as described previously (Beck *et al.* 1994, 1996; Birnstiel and Beck, 1995). Male Sprague-Dawley rats (Harlan) 75-100g were used for all treatment groups. Bilateral adrenalectomies were performed on all treatment groups, except the SHAM group, to remove circulating corticosteroids. The animal was anesthetized with ether, a small incision was made into the abdominal cavity, just below the rib cage, and the adrenal glands carefully removed. The muscle wall was then sutured and the skin closed using wound clips. The ADX group received no further treatment. The ALD group had an osmotic minipump containing aldosterone (Alzet model 2002), implanted subcutaneously at the time of adrenalectomy, to selectively activate MR. The minipump delivered 10 µg/h aldosterone dissolved in propylene glycol. MR and GR were activated in another group of animals (HCT) by subcutaneously implanting 200-300 mg corticosterone pellets, 2 to 3 week release, in the back of the neck at the time of adrenalectomy. The SHAM group of animals was produced by visualizing the adrenal glands but leaving them intact. After surgery the animals were maintained on a standard twelve hour light/dark cycle and rat chow, *ad libitum*. SHAM animals were given standard drinking water while the ADX, ALD, and HCT animals were given 0.9 % NaCl drinking water *ad libitum*. At the end of 13 - 15 days, the animals were sacrificed in the morning and

hippocampal slices immediately prepared for electrophysiological recording. At the time of sacrifice, trunk blood was collected to determine the plasma corticosterone levels by radioimmune assay (Burgess and Handa, 1992).

Hippocampal Slice Preparation

Hippocampal slices were prepared for electrophysiological recording as previously described (Okuhara and Beck, 1994). Rats were sacrificed by decapitation and the brain rapidly removed and placed in ice cold artificial cerebrospinal fluid (ACSF) containing in mM: NaCl 125, KCl 3, NaH₂PO₄ 1.25, MgSO₄ 2, CaCl₂ 2.5, dextrose 10, and NaHCO₃ 28. The ACSF was also supplemented with steroids, as outlined in **Table 1** (pg. 64), to maintain the treatment paradigm. We previously reported that steroids must be present in the ACSF to preserve the corticosteroid-induced effects on neuron cell properties (Beck *et al.*, 1994). The hippocampus was dissected free and the dorsal section cut in 500 - 550 μ m sections on a vibratome. The hippocampal slices were then placed in a holding vial containing ACSF bubbled with 95% O₂-5% CO₂ at room temperature. The slices remained in the holding vial for at least one hour after dissection before being transferred to the recording chamber. In the recording chamber, the slice was stabilized between two nylon nets and continuously perfused with ACSF bubbled with 95% O₂-5% CO₂ at a rate of 2-3 ml/min, at 31-32°C.

Intracellular Recording

Intracellular recordings were made as previously described (Okuhara and Beck, 1994). Electrodes were pulled from borosilicate capillary tubing on a Brown and Flaming electrode puller (Sutter Instruments) to a resistance of 30-35 M Ω (2 M KCl). Pyramidal cells were impaled with brief ejections of positive current through the electrode. The impaled cells were sealed by applying 1 nA hyperpolarizing current. Electrical signals were collected and amplified using an Axoclamp 2A and Cyberamp 320 amplifier (Axon Instruments, Foster City, CA) and recorded on a Gould Series 3200 chart recorder (Gould Electronics, Valley View, OH). Data were collected on-line with pCLAMP software (Axon Instruments).

Discontinuous single-electrode voltage clamp (dSEVC) technique was used under the following conditions. Briefly, the slice was perfused with 1 μ M tetrodotoxin and the capacitance compensation was set and switching frequency adjusted to 4 kHz at the beginning of the experiment. The cells membrane potential was clamped at a gain of 8 nA/mV and headstage continuously monitored.

5-HT Concentration-Response

Cells were voltage clamped at -65 mV and data for the 5-HT concentration response curves were collected by perfusing the slice with increasing 5-HT concentrations (3, 10, 30, and 100 or 110 μ M) and the maximum current response

evoked during the drug application was recorded. During drug perfusion, if the voltage clamp deviated by more than 1 mV, the data was discarded.

The magnitude of the current response was fitted to a hyperbolic function (Okuhara and Beck, 1994; Beck *et al.*, 1996):

$$E = E_{\max} / [1 + (EC_{50} / [5\text{-HT}])^N]$$

where E is the current produced at the 5-HT concentration [5-HT], E_{\max} is the maximal current response, EC_{50} is the 5-HT concentration which produces half the E_{\max} response, and N is the slope index. The fitted E_{\max} , EC_{50} and N values within each experimental group were used for statistical comparisons.

Experiments with GTP γ S

The effect of corticosteroids on G protein activity was determined by measuring the magnitude of outward current evoked by 15 mM GTP γ S which was included in the recording electrode. After the cell's membrane potential stabilized, the cell was voltage clamped at its resting membrane potential (i.e., the potential where no current was required to maintain the voltage clamp). The voltage clamp was then moved to -60 mV and the amount of current required to maintain the clamp was recorded.

I-V Relationship

The effect of corticosteroids on the potassium current linked to the 5-HT $_{1A}$ receptor was determined by plotting the I-V curve for the outward current evoked by

the activation of the 5-HT_{1A} receptor. After the cell's membrane potential stabilized, the cell was voltage clamped at its resting membrane potential (the potential where no current was required to maintain the voltage clamp). Data for IV plots were obtained by running voltage ramps in the presence and absence of 100 μ M 5-HT. Voltage ramps were run from approximately -125 mV to -30 mV at a rate of 1 mV/s. The I-V plot for the potassium current evoked by the activation of the 5-HT_{1A} receptor was constructed by subtracting the control ramp values (no 5-HT) from the ramp values in the presence of 100 μ M 5-HT. The reversal potential and potential where inward rectification occurred were analyzed for each curve.

Statistical Analysis

Statistical comparisons were performed using analysis of variance (ANOVA). The Student-Newman-Keuls method was used for post-hoc tests. All values are reported as mean \pm SEM. A $p < 0.05$ was considered significant.

Results

Corticosterone Plasma Levels

SHAM corticosterone plasma levels ranged from 0 - 4.13 μ g/dl (1.35 ± 0.32 μ g/dl, $n = 15$). ADX corticosterone plasma levels ranged from 0 - 0.22 μ g/dl (0.06 ± 0.03 μ g/dl, $n = 12$). ALD corticosterone plasma levels ranged from 0 - 0.56 μ g/dl ($0.07 \pm$

0.05 $\mu\text{g}/\text{dl}$, $n = 16$). The lower and upper limits of the corticosterone radioimmune assay were 0.05 and 50 $\mu\text{g}/\text{dl}$ respectively. Adrenalectomies that produced corticosterone concentrations ≤ 0.6 $\mu\text{g}/\text{dl}$ were considered successful. Two SHAM, 8 ADX, and 14 ALD animals had corticosterone levels less than 0.05 $\mu\text{g}/\text{dl}$. The concentration of aldosterone used in our experiments was based on an investigation by Kuroda *et al.*, (1994). The ALD treatment decreased MR binding by 61% ($n=5$ animals) in the cytoplasm (data not shown) as determined using a homogenate binding assay. HCT plasma concentrations greater than 20 $\mu\text{g}/\text{dl}$ were considered successful. HCT corticosterone plasma levels ranged from 25 to > 50 $\mu\text{g}/\text{dl}$ (34 ± 3 $\mu\text{g}/\text{dl}$, $n = 16$).

5-HT Concentration Response Curve Characteristics for the 5-HT_{1A} Receptor

Activation of the 5-HT_{1A} receptor evoked an outward current in a concentration-dependent manner (**Figure 9A**). The 5-HT concentration-response curve characteristics recorded from cells from corticosterone treated animals are summarized in **Table 6**. The EC₅₀ obtained in cells from ADX treated rats was smaller compared to cells from either SHAM, ALD, or HCT treated animals (**Figure 9B**). The Emax value was also smaller in cells from HCT when compared to cells from SHAM or ADX treated animals (**figure 9B**). Corticosterone treatment did not alter the slope index.

Perfusion of hippocampal slices with 5-HT may activate a number of different 5-HT receptor subtypes. Two 5-HT receptors subtypes which may be activated by 5-HT

and thereby modulate the 5-HT_{1A} current are the 5-HT₄ and 5-HT₇ receptors. Both of these receptors are located in the hippocampus (Lovenberg *et al.*, 1993; Meyerhor *et al.*, 1993; Ruat *et al.*, 1993; Jakeman *et al.*, 1994; Roychowdhury *et al.*, 1994; Waeber *et al.*, 1994) and are positively coupled to adenylyl cyclase (Lovenberg *et al.*, 1993; Ruat *et al.*, 1993; Shen *et al.*, 1993; Tsou *et al.*, 1994). Activation of the 5-HT₄ receptor produces a slow depolarizing response in subfield CA1 pyramidal cells (Andrade and Chaput, 1991). Since the 5-HT₄ and 5-HT₇ receptors have not been characterized in subfield CA3, we determined if activation of these receptors altered the 5-HT induced outward current recorded in subfield CA3. The magnitude of the outward current elicited by 30 μ M 5-HT was not altered by the administration of 1 μ M GR113808 and ritanserin (n = 6) (**Figure 10**), 5-HT₄ and 5-HT₇ receptor antagonists, respectively (Boess and Martin, 1994; Torres *et al.*, 1994). Perfusion of the slice with 30 μ M 5-HT while blocking the 5-HT_{1A} receptor with either 1 μ M WAY 100635 or 3 μ M spiperone did not produce either a depolarizing or inward current response (n=3) (data not shown).

Activation of G proteins with GTP γ S

The injection of GTP γ S into neurons produced a hyperpolarization of the resting membrane potential. There was no difference in the resting membrane potential between treatment groups. The resting membrane potentials were SHAM -76 ± 1 mV, ADX -79 ± 2 mV, ALD -74 ± 1 mV, and HCT -76 ± 1 mV. The relative amount of

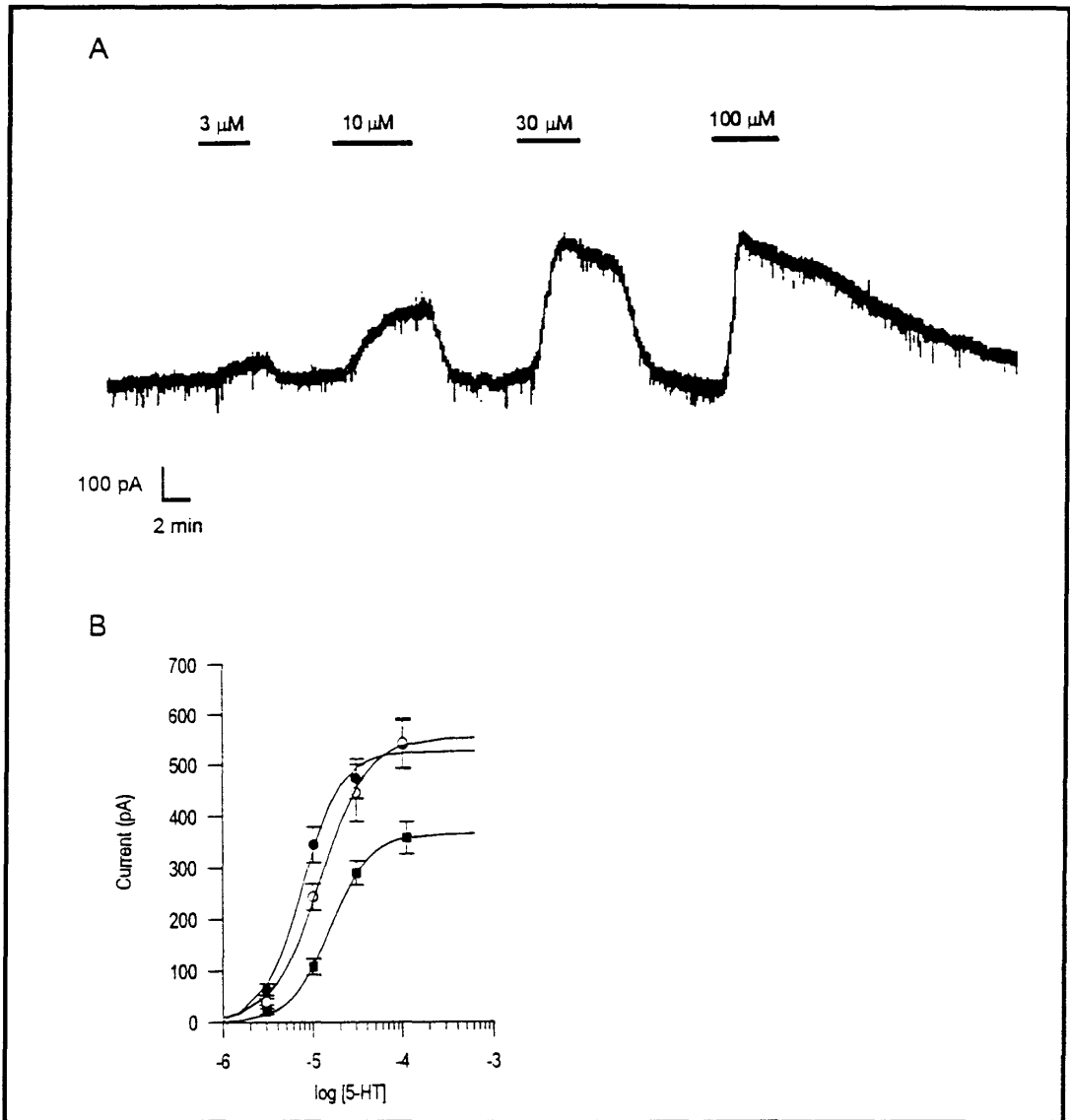

Figure 9. Concentration-dependent response of subfield CA3 pyramidal cells to 5-HT perfusion. **A:** Chart recording of the concentration-dependent current response of a CA3 cell to 5-HT perfusion. The drug was applied for the duration depicted by the line above the chart record. **B:** Concentration-response curves from data collected from all of the cells from SHAM (open circles), ADX (closed circles) and HCT (closed squares) treated animals. The data were fit to a hyperbolic function as described in MATERIALS AND METHODS in this chapter.

Table 6.--The effect of corticosteroids on the 5-HT concentration-response curve characteristics for the 5-HT_{1A} receptor

Treatment	EC ₅₀ (-log)	E _{max} (pA)	N
SHAM	4.96 ± 0.06 (15)	551 ± 46 (15)	2.0 ± 0.1 (15)
ADX	5.12 ± 0.04 ^a (18)	540 ± 47 (16)	2.3 ± 0.1 (18)
ALD	4.96 ± 0.03 (16)	469 ± 39 (15)	2.4 ± 0.2 (16)
HCT	4.85 ± 0.04 (15)	360 ± 30 (15) ^b	2.3 ± 0.2 (15)

All values are reported as mean ± SEM (n)

^a ANOVA F = 11.631; d.f. = 3, 60; P < 0.001. Student-Newman-Keuls, ADX different from SHAM, ALD, and HCT, p < 0.05.

^b ANOVA F = 4.302; d.f. = 3, 60; P < 0.008. Student-Newman-Keuls, HCT different from SHAM and ADX, p < 0.05.

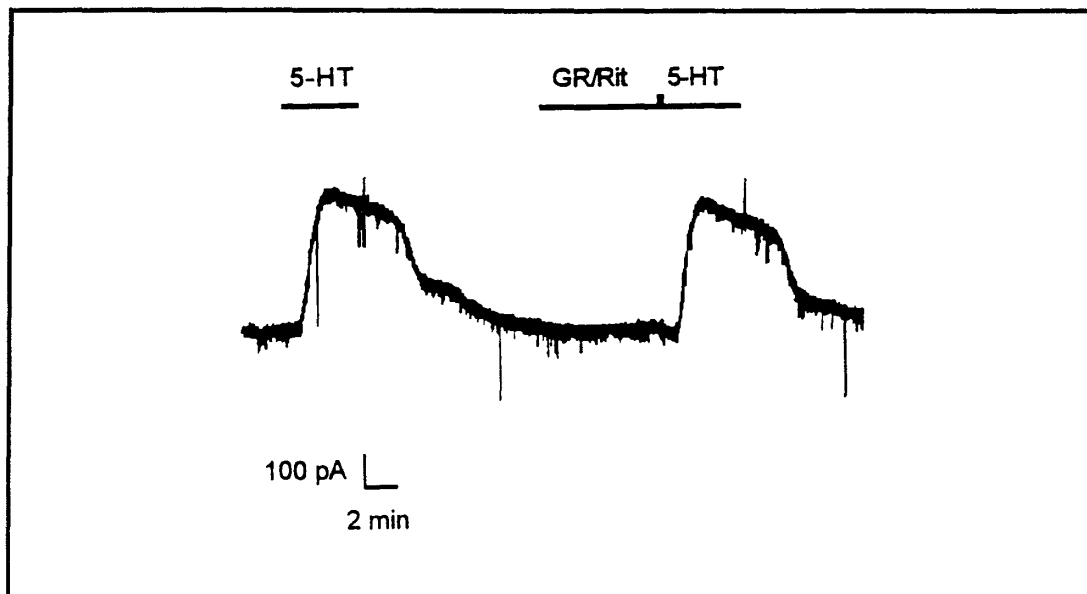

Figure 10. The outward current elicited by the perfusion of 30 μM 5-HT in the presence and absence of 5-HT₄ and 5-HT₇ receptor antagonists. The outward current elicited by the perfusion of 30 μM 5-HT in the presence and absence of 1 μM of the 5-HT₄ and 5-HT₇ receptor antagonists GR113808 and ritanserin. The drugs were applied for the duration depicted by the line above the chart record. The magnitude of the outward current evoked by 5-HT was not different ($p = 0.141$, $n = 6$, paired t-test) in the presence or absence of GR113808 and ritanserin.

current evoked by the activation of G proteins with GTP γ S was determined by voltage clamping the cell's membrane at its resting potential (when zero current is required to maintain the voltage clamp). The voltage clamp was then moved to -60 mV for several minutes (**Figure 11A**). The amount of current required to maintain the voltage clamp at -60 mV was used as a measure of the amount of current evoked by the activation of G proteins with GTP γ S. **Figure 11B** summarizes the results of these experiments.

Significantly less current was required in cells from HCT when compared to cells from SHAM, ADX, and ALD treated animals. The amount of current measured in cells from SHAM was also smaller compared to cells from ADX treated animals.

I-V relationship

I-V plots for the 5-HT_{1A} evoked potassium current were analyzed in 2 to 3 cells from ADX, SHAM and HCT treated animals. Representative I-V plots in **Figure 12A-C** demonstrate that corticosterone does not appear to alter the reversal potential nor the inward rectification properties for the potassium current linked to the 5-HT_{1A} receptor. The reversal potential was between -97 to -104 mV and rectification started at approximately -50 mV.

Discussion

The 5-HT_{1A} receptor is a member of the G protein-linked receptor family. In the present study, we report the effects of chronic corticosteroid treatment on different components of the 5-HT_{1A} signal transduction system in hippocampal subfield CA3 pyramidal cells using electrophysiological techniques. The EC₅₀ value for the 5-HT concentration-response curve was shifted to the left in cells from ADX treated animals compared to SHAM, ALD, and HCT. The E_{max} value was smaller in cells from HCT animals compared to ADX and SHAM. The shift in the 5-HT_{1A} response may be due to alterations at sites downstream of the 5-HT_{1A} receptor. Therefore, we compared the

Figure 11. The outward current evoked by GTP γ S. A: Chart recording of a cell injected with GTP γ S. The cell's membrane potential was first voltage clamped at its resting potential (-74 mV, I = 0 pA). The clamp was then moved to -60 mV and the current recorded (I = 340 pA). Perfusion of 100 μ M 5-HT (duration depicted by the line above the chart record) did not elicit a current response, indicating all the G proteins linked to 5-HT receptors were activated by GTP γ S. **B:** Summary graph depicting the amount of current evoked by GTP γ S in cells from corticosterone treated animals. Treatment group and number of cells are labeled at the bottom axis.

ANOVA $F = 12.691$; d.f. = 3, 61; $P < 0.001$.

*HCT different from SHAM, ADX, and ALD. Student-Newman-Keuls, $p < 0.05$,

#ADX different from SHAM. Student-Newman-Keuls, $p < 0.05$.

A

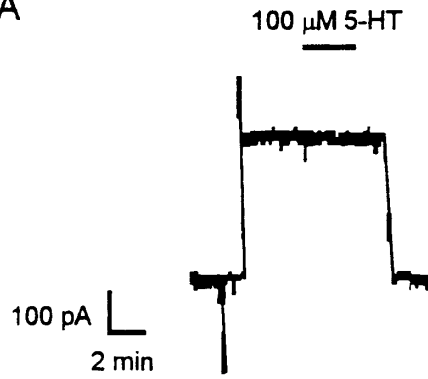

B

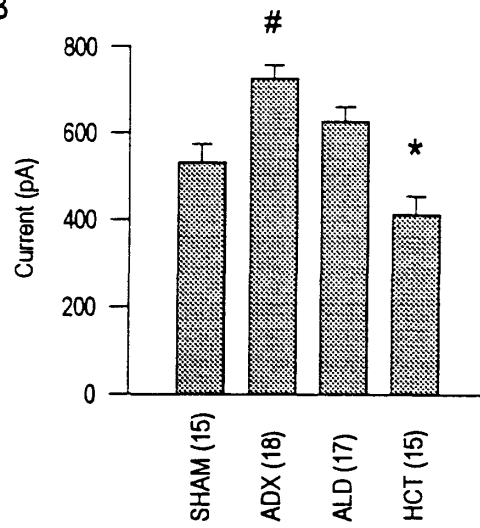

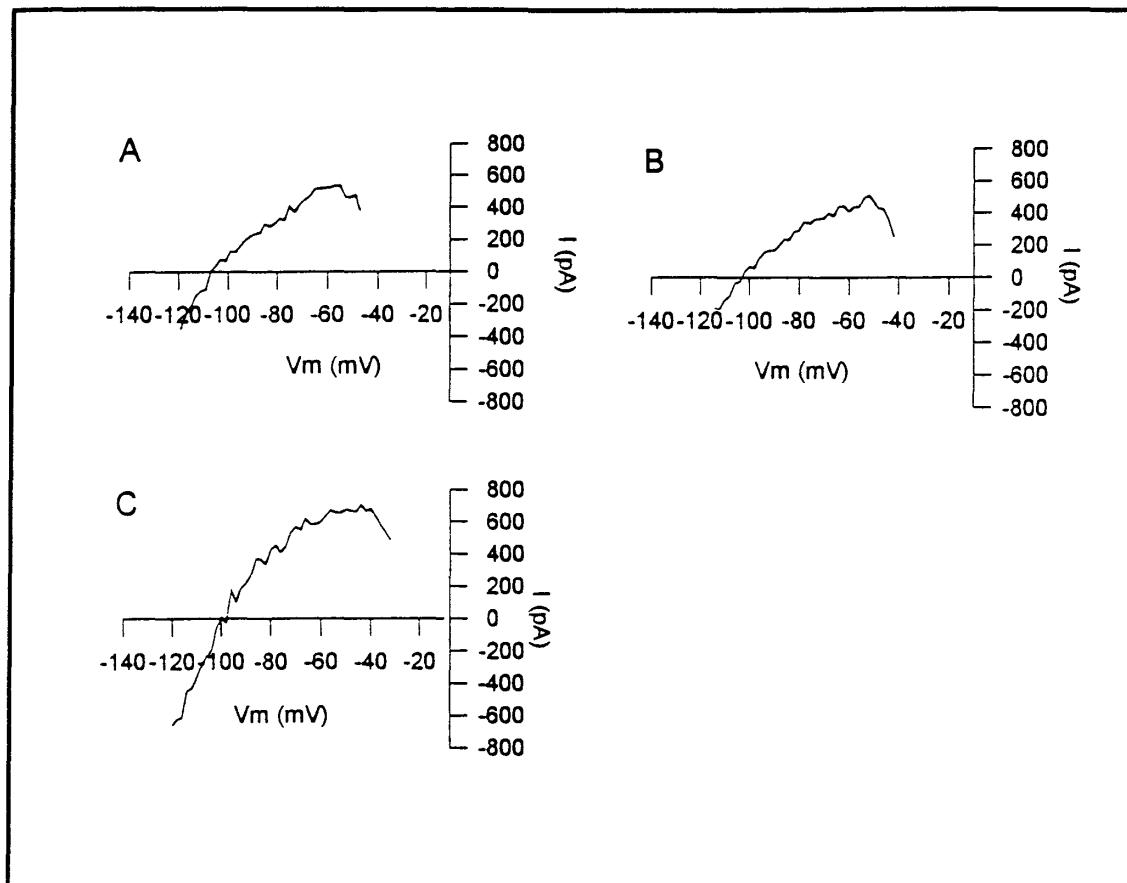

Figure 12. I-V plots of steady-state 5-HT mediated current in corticosteroid treated animals. I-V plot of steady-state 5-HT mediated current in a cell from either a A: SHAM, B: ADX, or C: HCT treated animal.

magnitude of the outward current evoked by the activation of G proteins with GTP γ S. Less current was evoked by GTP γ S in cells from HCT animals compared to ADX, SHAM, and ALD. Furthermore, less current was evoked by GTP γ S in cells from SHAM compared to ADX animals. Finally, we determined the effects of corticosteroids on the I-V relationship of the potassium current elicited by the activation of the 5-HT_{1A} receptor. Corticosteroid treatment did not alter the reversal potential or inward rectification properties of the potassium current linked to the 5-HT_{1A} receptor. Based on our results and those previously reported by other investigators, we conclude that corticosteroids alter the response elicited by the activation of 5-HT_{1A} receptors by modulating the receptor's signal transduction system at different sites.

Alterations in the number of 5-HT_{1A} binding sites may account for some of the changes we observed in the 5-HT concentration response curve characteristics. Previous investigators reported that adrenalectomy increases the number of 5-HT_{1A} receptor binding sites in subfield CA3 when compared to either SHAM, aldosterone, low or high corticosterone treated animals (Mendelson and McEwen, 1992a,b; Chalmers *et al.*, 1993; Kuroda *et al.*, 1994; Tejani-Butt and Labow, 1994). The increased number of 5-HT_{1A} receptor binding sites may account for the shift in EC₅₀, with no change in E_{max}, for the 5-HT concentration-response curve that we observed

in cells from ADX compared to SHAM and ALD treated animals. A shift in EC_{50} , with no change in E_{max} , may occur with spare receptors (Stephenson, 1956; Yocca *et al.*, 1992).

It is not clear if the smaller E_{max} in cells from HCT compared to SHAM treated animals is due to a decrease in the number of 5-HT_{1A} binding sites. It has been reported that high levels of corticosterone (plasma concentrations > 40 µg/dl) do not change the number of 5-HT_{1A} binding sites in subfield CA3 compared to sham treated animals (Mendelson and McEwen, 1992a). However, social and restraint stress does decrease the number of 5-HT_{1A} binding sites in the hippocampus (Watanabe *et al.*, 1993; McKittrick *et al.*, 1995). One possible explanation for the discrepancy is the treatment length. Mendelson and McEwen (1992b) treated their animals with a corticosterone pellet implant for 7 days. The investigations that examined the effects of stress treated their animals for 14 days (Watanabe *et al.*, 1993; McKittrick *et al.*, 1995). It is possible that exposure to elevated corticosterone plasma levels must exceed 7 days before the down regulation of 5-HT_{1A} binding sites occurs.

Alternatively, the stress response may be activating other physiological processes, in addition to increasing corticosterone plasma levels, that induces the down regulation of 5-HT_{1A} binding sites.

Corticosteroids also alter the 5-HT_{1A} signal transduction system downstream of the receptor. ADX increased while HCT decreased the magnitude of the current

evoked by the activation of G proteins with GTP γ S. Corticosteroids could be altering G protein levels, G protein coupling, or the properties of the channels linked to the G proteins. However, the attenuated 5-HT_{1A} mediated-response and G protein-evoked current cannot be attributed to a decrease in G protein expression. We observed that HCT treatment increased G_o and G_{i1&2} α -subunit levels in the hippocampus (Okuhara *et al.*, 1996a), the PTX-sensitive G proteins thought to be linked to the 5-HT_{1A} receptor (Andrade *et al.*, 1986; Okuhara and Beck 1994). Based on our present results, we propose that the increased G protein levels may be a compensatory response to a decrease in G protein function.

Interestingly, while corticosterone clearly had an effect on the magnitude of the outward current evoked by GTP γ S, there was no change in the resting membrane potential of pyramidal cells between treatment groups. A simple explanation for this observation is the non-linear relationship between voltage and resistance (shunting). Shunting accounts for large changes in current with only small changes in membrane potential. Therefore, the activation by GTP γ S of ion channels with non-linear I-V relationships (i.e., GIRK) could evoke different amounts of current but produce similar changes in membrane potential in cells from the different treatment groups. Alterations in the 5-HT_{1A} receptor-mediated response and G protein-linked current could be attributed to a change in pyramidal cell resting input resistance. However, corticosteroid treatment did not alter neuron resting input resistance in subfield CA3

pyramidal cells (Okuhara *et al.*, 1996b). While we were able to detect corticosteroid-induced changes in the current evoked by the activation of G proteins we do not know if corticosterone is altering G protein function or the coupling between the G protein and potassium channel. We also do not know which G protein-linked current(s) was modulated by corticosterone.

The potassium channel linked to the 5-HT_{1A} receptor signal transduction system is probably a member of the recently cloned G protein inward rectifying potassium (GIRK) channel family (Lesage *et al.*, 1994, 1995; Kobayashi *et al.*, 1995; Ponce *et al.*, 1996; Spausches *et al.*, 1996). ADX, ALD, and HCT treatment did not alter the reversal potential or inward rectification properties of the potassium current linked to the activation of the 5-HT_{1A} receptor. However, alterations in potassium channel kinetic properties cannot be ruled out.

ADX had different effects on the 5-HT concentration response curve characteristics in cells from subfield CA1 and CA3. Previous studies reported that the concentration-response curve characteristics for the 5-HT_{1A} mediated hyperpolarization in subfield CA1 was not altered by adrenalectomy or chronic activation of MR with low levels of corticosterone as compared to sham (Joëls *et al.*, 1991, Joëls and de Kloet, 1992; Beck *et al.*, 1996). In the present investigation, ADX shifted the EC₅₀ value for 5-HT_{1A} mediated outward current compared to SHAM and ALD (chronic MR activation). Previously, we reported that the 5-HT_{1A} receptor signal transduction

system is not identical between subfields CA1 and CA3, based on different 5-HT concentration-response curve characteristics for the 5-HT_{1A} receptor in the two subfields (Beck *et al.*, 1992; Okuhara and Beck, 1994). Therefore, it is possible that corticosteroids have different effects on the 5-HT_{1A} receptor-mediated response in subfields CA1 and CA3.

In conclusion, chronic corticosterone treatment alters the response elicited by the activation of 5-HT_{1A} receptors in hippocampal subfield CA3 pyramidal cells. Some of the modulatory actions of corticosterone occur downstream of the receptor, at the G protein level. Furthermore, ADX and high corticosterone treatment have opposite effects on the 5-HT_{1A} signal transduction system. Our results provide important information towards understanding how corticosterone modulates neurotransmitter receptor-mediated responses in the hippocampus.

CHAPTER V

DIFFERENTIAL IMMUNOHISTOCHEMICAL LABELING OF G_s , $G_{i1 \text{ and } 2}$ AND G_o α -SUBUNITS IN RAT FOREBRAIN

Abstract

In the previous chapter, it was concluded that corticosterone treatment alters the 5-HT_{1A} receptor signal transduction system at sites downstream of the receptor. The 5-HT_{1A} receptor couples to a PTX-sensitive G protein, therefore, corticosteroids may influence G protein levels and/or their intracellular location. Since a comparative study of the anatomical and morphological distribution of the G proteins G_o , $G_{i1 \text{ and } 2}$, and G_s α -subunits in the hippocampus has not been reported, such an investigation was conducted using immunohistochemical techniques with rat forebrain sections prepared from naive animals. Diffuse G_o labeling occurred in the neuropil throughout the cortex, superficial layers of the entorhinal cortex, thalamus, several white matter fiber tracts and hippocampus. $G_{i1 \text{ and } 2}$ immunoreactivity was also located in the neuropil but produced a more fibrous pattern. Fibrous labeling of $G_{i1 \text{ and } 2}$ was observed in the cortex, amygdala, hippocampal subfield CA3 and several white matter fiber tracts. Both G_o and $G_{i1 \text{ and } 2}$ labeling was present in the pencil fibers within the striatum and lateral geniculate nucleus. G_s labeling, in contrast to G_o and $G_{i1 \text{ and } 2}$, was generally cytoplasmic. Cytoplasmic

G_s labeling was observed in the thalamus, habenula, dentate, geniculate nucleus, hypothalamus, and hippocampus. Intense G_s labeling was observed in the striatum parenchyma, choroid plexus and infundibular stem.

Based on our results, we conclude that the G proteins G_o , $G_{i1 \text{ and } 2}$, and G_s are anatomically distributed differently throughout the brain. The diffuse neuropil labeling of G_o , fibrous neuropil labeling of $G_{i1 \text{ and } 2}$ and cytoplasmic labeling of G_s strongly suggests that the G proteins are also differentially distributed morphologically within a neuron. The differential anatomical and cellular location of G proteins in the CNS may contribute to the coupling specificity between neurotransmitter receptors and G proteins.

Introduction

Heterotrimeric G proteins transduce extracellular signals into a cell by coupling plasma membrane receptors with effector molecules. G proteins are composed of three subunits: α , β , and γ . The α -subunit binds and hydrolyzes GTP and modulates effector molecule activity (Gilman, 1987). There are several subtypes of G proteins based on the sequence of their α -subunits. Four of these are G_i , G_o , G_s and G_t (Birnbaumer *et al.*, 1990). The different G protein α -subunits are differentially sensitive to ADP-ribosylation by several toxins. The G proteins G_i and G_o are ADP ribosylated by PTX while G_s is sensitive to cholera toxin (Gilman, 1987). The $\beta\gamma$ subunits anchor the

G protein complex to the cytoplasmic membrane and also modulate the activity of the effector molecule (Birnbaumer *et al.*, 1990).

The effector molecules are either ion channels or proteins that synthesize second messenger molecules (i.e., cyclic AMP or inositol triphosphate), which in turn, modulate enzyme activity in the cell (reviewed by Birnbaumer *et al.*, 1990; Clapham, 1994). For example, G_s increases adenylyl cyclase activity and modulates Ca^{2+} activated-potassium channels, G_i decreases adenylyl cyclase activity and activates potassium channels while G_o decreases the current linked to Ca^{2+} channels in the central nervous system.

Current research has focused on elucidating the specificity between receptor and G protein coupling. A cursory examination indicates that a cell may express more types of receptors than G proteins and that these multiple receptor subtypes can share the same G protein (Birnbaumer, 1992). The specificity of receptor-G protein coupling is probably established at several different levels. Factors that contribute to the receptor-G protein specificity are: amino acid sequences in the different G protein subunits (Gilman, 1987; Kleuss *et al.*, 1993), cytoskeletal proteins (Rodbell, 1990; Sarndahl *et al.*, 1991), and compartment localization (i.e., golgi and mitochondria) (Ercolani *et al.*, 1990). The asymmetrical distribution of G proteins within rat enterocytes (Van den Berghe *et al.*, 1991) and in the kidney (Stow *et al.*, 1991) suggests that the cellular location of G proteins may also contribute to G protein-receptor coupling specificity.

In the brain, two other factors also contribute to the coupling specificity between receptors and G proteins: the intracellular (i.e., soma and dendrites) and anatomical location of the G protein. There is information on the distribution of G proteins in only a few brain areas including the cortex (Asano *et al.*, 1987, 1990a,b; Aoki *et al.*, 1992), hippocampus (Asano *et al.*, 1990b; Aoki *et al.*, 1992), basal ganglia (Hervé *et al.*, 1993), cerebellum (Asano *et al.*, 1987, 1990a; Nishida *et al.*, 1991) and olfactory bulb (Asano *et al.*, 1990a; Shinohara *et al.*, 1992). In the previous chapter, it was concluded that corticosterone treatment alters the 5-HT_{1A} receptor signal transduction system at sites downstream of the receptor. The 5-HT_{1A} receptor couples to a G protein, therefore, corticosteroids may influence G protein levels and/or their intracellular location. Since the comparative anatomical and morphological distribution of the G_o, G_{i1 and 2}, and G_s α -subunits in the hippocampus are not known, in the present study, we examined the anatomical and intracellular distribution of G_{i1 and 2}, G_o, and G_s α -subunits in the rat forebrain using immunohistochemical techniques with rat forebrain sections prepared from naive animals.

Materials and Methods

Materials

Primary anti-G protein polyclonal antibodies were purchased from Dupont-New England Nuclear (Boston, MA). Monoclonal rabbit peroxidase-antiperoxidase antibody was purchased from Cappel (Durham, NC). Picric acid was purchased from Aldrich

(Milwaukee, WI). 3,3'-diaminobenzidine tetrachloride (DAB) was purchased from Sigma (St. Louis, MO). All other chemicals were obtained from commercial sources.

Immunohistochemical Procedure

Four male Sprague-Dawley rats (170-230g) were sacrificed with a lethal injection of phenobarbital and perfused with 200 ml PBS (10 mM NaHPO₄, pH 7.4, and 150 mM NaCl) *via* the aorta at 650 ml/hr followed by 250 ml PA fixative (4% paraformaldehyde, 1% glutaraldehyde, 0.2% picric acid, 2% sucrose, 0.1 M acetate buffer, pH 6.0) as described previously (Asano *et al.*, 1990b). After fixation, the brain was removed, blocked, and placed in PA for 4-6 hrs. After rinsing and overnight incubation in TBS (10 mM Tris, pH 7.6 and 150 mM NaCl) with 10% sucrose, the tissue was embedded in paraffin, sectioned at 7 μ m, and mounted on microscope slides.

Immunohistochemistry was performed following protocols described by Sternberger *et al.*, (1970). Briefly, tissue sections were blocked with TBS/5% bovine serum albumin (BSA)/3% normal goat serum (NGS) for one hour at room temperature. After washing the sections with TBS, three times for 10 minutes each, they were incubated with 1:50 anti-G_{sc} (RM1), 1:50 anti-G_{I α 1 and 2} (AS7), or 1:100 anti-G_{oc} (GC2) overnight at room temperature. Several sections were incubated with 2% NGS in place of primary antibody to determine the level of nonspecific labeling. Sections were then washed with TBS, three times for 10 minutes each, and incubated with 1:20 goat anti-rabbit IgG. After one hour, sections were washed with TBS and incubated with rabbit peroxidase-

antiperoxidase for one hour. Subsequently, the sections were washed in TBS and developed with hydrogen peroxide and DAB as the chromagen. All antibody dilutions were made in TBS/5% BSA/3% NGS.

Silver Intensification

Selected DAB developed sections were intensified with silver as described by Kitt *et al.*, (1994). All reagents used for intensification were freshly prepared. Briefly, after developing the sections with DAB and hydrogen peroxide, sections were dehydrated and rehydrated through a graded series of deionized water, alcohol, and xylenes. Sections were then placed in a 2.5% silver nitrate solution for 1 hour at 56°C. After washing in deionized water for 10-15 min, the sections were incubated in 2% gold chloride solution for 10 min at room temperature. Sections were then rinsed in deionized water for 5 min and incubated in a 5% sodium thiosulfate solution for 5 min at room temperature. Sections were washed for 10 min in deionized water and immediately dehydrated through a series of graded alcohols and xylenes.

Western Blot Analysis

Western blots were performed on membrane protein preparations from the hippocampus as described elsewhere (Sternweis and Robinshaw, 1984). Protein isolation procedures were carried out at 4°C. The hippocampus was homogenized with a hand-held dounce homogenizer in TBS, 10% sucrose, and 0.5 mM phenylmethan-

sulfonyl fluoride. The homogenate was then centrifuged at 20,000 X g for 30 min. The supernatant was removed and the membrane pellet resuspended in a second identical wash and centrifuged again at 20,000 X g for 30 min. The supernatant was discarded and the membrane pellet resuspended in TBS, 1 mM EDTA and 1% sodium cholate and incubated for 60 min. with constant mixing. The soluble membrane protein was collected by centrifugation at 35,000 rpm for 60 min. and stored at -80 °C.

Western blotting techniques used are described elsewhere (Lesch and Manji, 1992). Membrane proteins were resolved by SDS-PAGE and electrophoretically transferred to nitrocellulose membrane filters. After transfer, the nitrocellulose was blocked with TBS, 0.2% NP-40, and 5% nonfat dry milk at room temperature. After blocking for 60 min. the nitrocellulose was incubated with a 1/10,000 dilution of AS7, RM1, or GC2 overnight at 4°C. The nitrocellulose was then incubated with a 1/10,000 dilution of goat anti-rabbit IgG for 60 min. at room temperature followed by an incubation with 1/10,000 dilution of rabbit PAP. The blots were developed with the ECL detection kit (Amersham, Arlington Heights, IL) and exposed to x-ray film. All antibody dilutions were in TBS, 5% BSA, and 0.2% NP-40. The nitrocellulose filter was washed with TBS/0.2% NP-40 between every antibody incubation and prior to development with the ECL kit.

Results

Western blot analysis

The RM1 antibody consistently labeled a 45 kDa protein band in the Western blots (**Figure 13**) corresponding to the short form of G_s (Bray *et al.*, 1986; Robinshaw *et al.*, 1986; Kozasa *et al.*, 1988). A 54 kDa band (long form of G_s) was also detected but its detection was not consistent (data not shown). When the band was detected, it was faint and indistinct. The AS7 and GC2 antibodies labeled a single 40 kDa band (**Figure 13**) corresponding to the appropriate size for $G_{i1 \text{ and } 2}$ and G_o respectively (Goldsmith *et al.*, 1987; Cooper *et al.*, 1990).

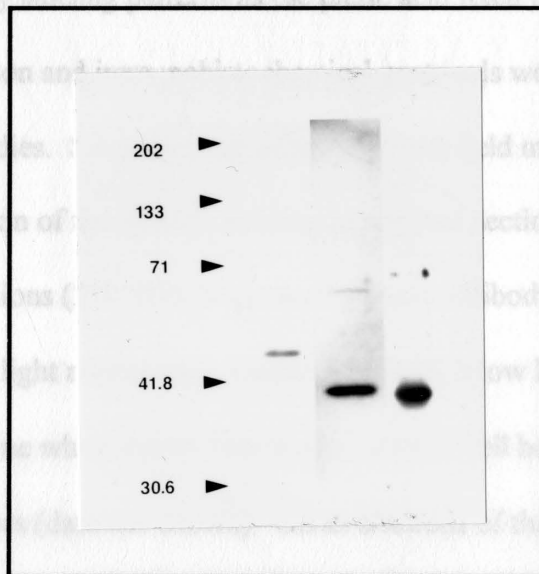

Figure 13. Western blot of G proteins in the rat hippocampus.

Lane 1: G_s (RM1 antibody). Lane 2: $G_{i1 \text{ and } 2}$ (AS7 antibody). Lane 3: G_o (GC2 antibody).

Immunohistochemical Techniques

The immunohistochemical labeling with the primary antibodies described in this investigation is very sensitive to variations in labeling and tissue preparation protocols. For instance, we found that the inclusion of 0.05% NP-40 detergent decreased G_s and $G_{i1 \text{ and } 2}$ labeling throughout the entire brain and the exclusion of BSA from the blocking solution increased nonspecific G_s labeling. The fibrous neuropil staining pattern observed with $G_{i1 \text{ and } 2}$ in paraffin embedded tissue was distorted in cryostat cut sections. Tissue prepared with a paraformaldehyde-lysine-periodate (PLP) fixative produced less intense but similar antibody labeling patterns as the picric acid fixed tissue. In the present study, the tissue preparation and immunohistochemical protocols were maximized and identical for all three antibodies. Silver intensification and dark field microscopy were used to increase visualization of the specific staining in selected sections.

In control sections (2% NGS in place of primary antibody), nonspecific labeling was faint under normal light microscopy. Under dark field, a low level of nonspecific labeling was detected in some white matter fiber tracts, cortical cell bodies and hippocampal pyramidal cell bodies (data not shown). Serial dilutions of the primary antibody decreased the intensity of labeling. The differential labeling by the three antibodies used in this study also demonstrates the specificity of antibody binding.

The technical data sheets supplied by Du Pont NEN also provided information on the specificity of the three antibodies. The $G_{i\alpha 1 \text{ and } 2}$ antibody, AS7, is specific for only

$G_{i\alpha 1 \text{ and } 2}$. The $G_{s\alpha}$ antibody, RM1, cross reacts with G_{of} . The G_o antibody, GC2, is specific for $G_{o\alpha}$.

Cortex

We observed G_o and $G_{i1 \text{ and } 2}$ immunoreactivity in the neuropil of the rat cortex but with different labeling patterns. G_o immunoreactivity was very intense and diffuse. $G_{i1 \text{ and } 2}$ immunoreactivity was very fibrous and less intense than G_o . Diffuse G_o labeling was observed in the neuropil throughout the entire cortex while neuronal cell bodies were not labeled. The immunoreactivity in the molecular layer (layer I) of the cortex was more intense than layers II-VI. The pyramidal cell bodies and dendritic processes in layer V were immunonegative and stood out against the positive neuropil (**Figure 14A**).

$G_{i1 \text{ and } 2}$ labeling in the cortex, and throughout the forebrain, was characterized by a fibrous pattern in the neuropil. The antibody also labeled individual fibers extending from the external capsule into the deep cortical layers V and VI (**Figure 14B**). The G_o or G_s antibody labeled the neuropil in a diffuse pattern and fiber labeling was not observed. In the entorhinal cortex, the superficial layers adjacent to the cortical amygdala and piriform cortex were also strongly immunopositive for G_i and G_o , however, we were not able to distinguish the different nuclei in the amygdala.

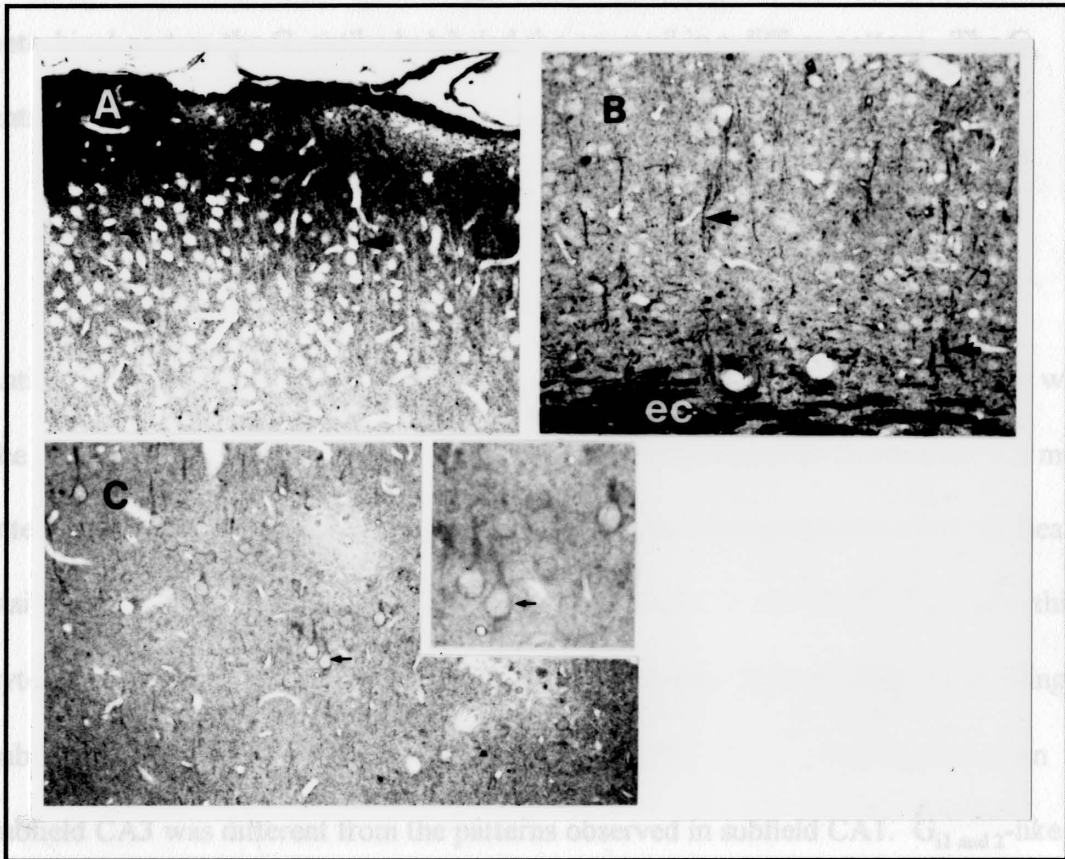

Figure 14. Photographs of G protein labeling in the cortex.

A: G_o labeling in the superficial cortical layers. Immunolabeling was located in the neuropil, while the neuronal cell body (large arrow) and processes (small arrow) were immunonegative. Note the intense labeling of G_o in layer I of the cortex (located near the top of photomicrograph). X200. **B:** $G_{i1 \text{ and } 2}$ labeling (intensified with silver) in the deep cortical layers adjacent to the external capsule (ec). Fibers arising from the external capsule (arrow) were intensely stained. X200. **C:** Cytoplasmic G_s labeling in a cell (arrow) located in the lateral middle cortical layers. X200. **Insert:** The same neuron (arrow) viewed at X300.

G_s labeling in the cortex displayed a generally light diffuse neuropil staining. However, in a few sections, cytoplasmic staining was present in cortical cells (**Figure 14C**). In the entorhinal cortex, the G_s antibody labeled the neuropil in a diffuse pattern. The G_s antibody did not label neuronal cell bodies in the entorhinal cortex.

Hippocampus

G protein immunoreactivity in the hippocampus was different for all three antibodies. In subfield CA1, G_o and $G_{i1 \text{ and } 2}$ labeling were detected in the neuropil while the pyramidal cell bodies were immunonegative (**Figure 15A,C**). G_o staining was more intense than $G_{i1 \text{ and } 2}$ and dendritic processes were often distinguished against the heavily stained neuropil. G_s immunoreactivity was also detected in subfield CA1 but as a thin cytoplasmic ring near the perimeter of the pyramidal cells (**Figure 15E**). G_o labeling in subfield CA3 was similar to subfield CA1 (**Figure 15B**). $G_{i1 \text{ and } 2}$ and G_s labeling in subfield CA3 was different from the patterns observed in subfield CA1. $G_{i1 \text{ and } 2}$ -like immunoreactivity was detected as fibrous patches surrounding the pyramidal cells in subfield CA3 (**Figure 15D**). G_s immunoreactivity in subfield CA3 was found throughout the entire neuronal cytoplasm (**Figure 15F**). Intense G_o and $G_{i1 \text{ and } 2}$ -like immunoreactivity was also detected in the fimbria.

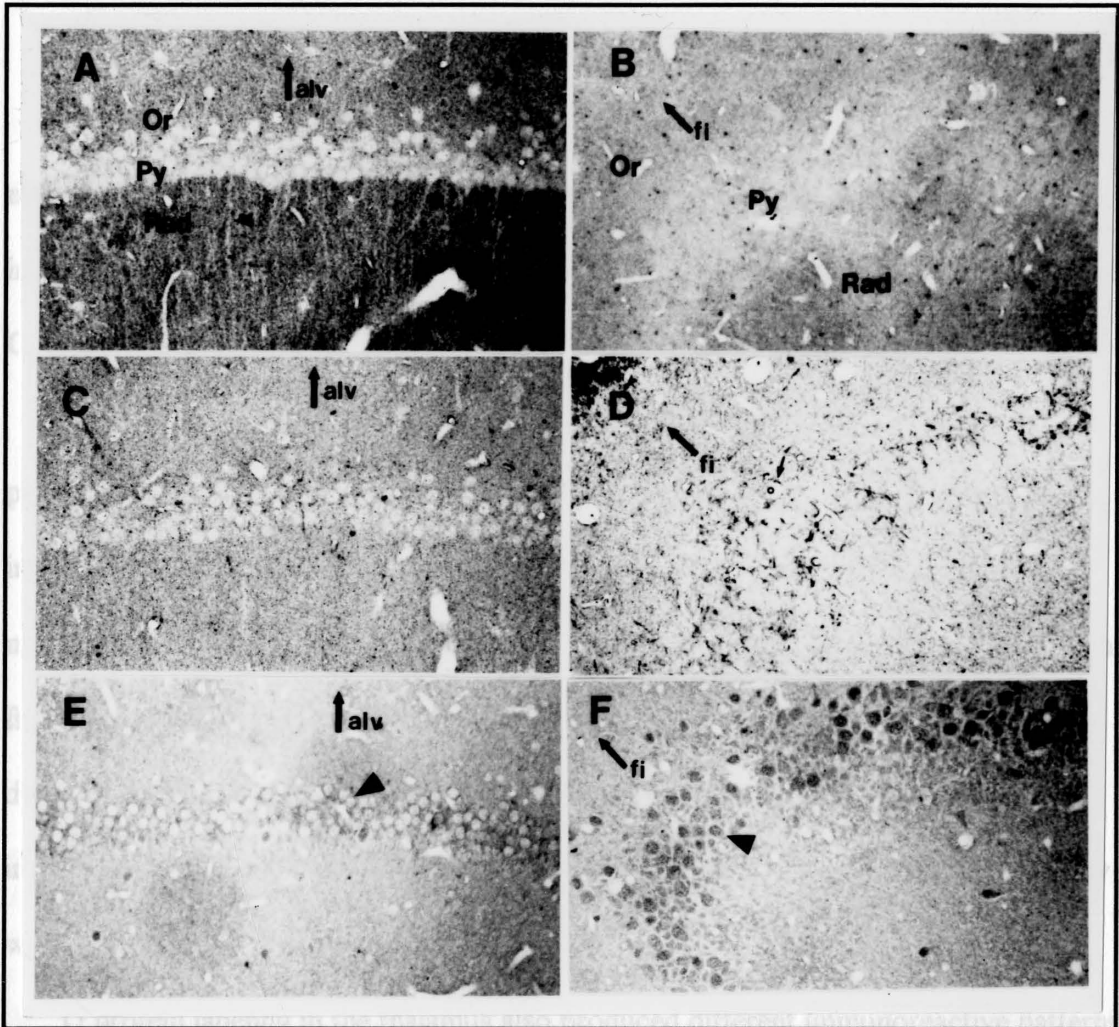

Figure 15. Photographs of G protein labeling in the hippocampus.

The labeling of G proteins in the hippocampal subfields CA1 (A,C,E) and CA3 (B,D,F). The radiata (Rad), orien (Or), and pyramidal striata (Py) in subfield CA1 (Panel A) and CA3 (Panel B) are indicated. All photomicrographs are at X200. **A:** G_0 labeling in hippocampal subfield CA1. Location of the alveus (alv) is marked by an arrow. Arrowheads point to immunonegative dendrites. **B:** G_0 labeling in subfield CA3. The diffuse labeling makes it difficult to delineate the different striata. Location of the fimbria (fi) is marked by an arrow. **C:** $G_{i1 \text{ and } 2}$ labeling (intensified with silver) in subfield CA1. alv, alveus. **D:** $G_{i1 \text{ and } 2}$ labeling (intensified with silver) in subfield CA3. A fibrous patch of $G_{i1 \text{ and } 2}$ labeling (small arrow) surrounding a pyramidal cell (hallow circle). Location of the fimbria (fi) is marked by the larger arrow. **E:** G_s labeling in the perimeter (arrowhead) of subfield CA1 pyramidal cells. alv, alveus. **F:** Cytoplasmic labeling of G_s in a pyramidal cell (arrowhead) located in subfield CA3. fi, fimbria.

Subcortical Nuclei

The three antibodies produced different labeling patterns in several subcortical nuclei. Generally, the G_o antibody labeled the neuropil in a diffuse pattern; $G_{i1 \text{ and } 2}$ immunoreactivity was also detected in the neuropil but produced a fibrous pattern; and G_s staining was located in the cytoplasm.

G protein labeling with all three antibodies in the striatum appears as irregular patches surrounding immunonegative cell bodies. Intense G_o and $G_{i1 \text{ and } 2}$ -like immunoreactivity was detected in the white matter pencil fibers of the striatum and a much lighter label in the parenchyma (**Figure 16A**). In contrast, G_s staining was absent from the pencil fibers but diffusely present within the striatum parenchyma and not detected in the cell cytoplasm (**Figure 16B**). In the habenula, G_o and $G_{i1 \text{ and } 2}$ immunoreactivity was located in the neuropil (**Figure 16C**) while G_s immunoreactivity was localized to the cell cytoplasm (**Figure 16D**).

G protein labeling in the thalamus also produced different immunoreactive patterns. Intense G_o and $G_{i1 \text{ and } 2}$ -like immunoreactivity was located in the neuropil of the ventral posterior thalamic nuclei (VPT) (**Figure 17A**). G_o and $G_{i1 \text{ and } 2}$ immunopositive myelinated fibers were also detected in the VPT. These fibers probably arise from the medial lemniscus and internal capsule. Moderate G_o and $G_{i1 \text{ and } 2}$ -like immunoreactivity was detected throughout the lateral thalamic posterior nuclei (LP), and dorsal and ventral lateral geniculate nuclei (DLG, VLG). Moderate G_s labeling was detected in the

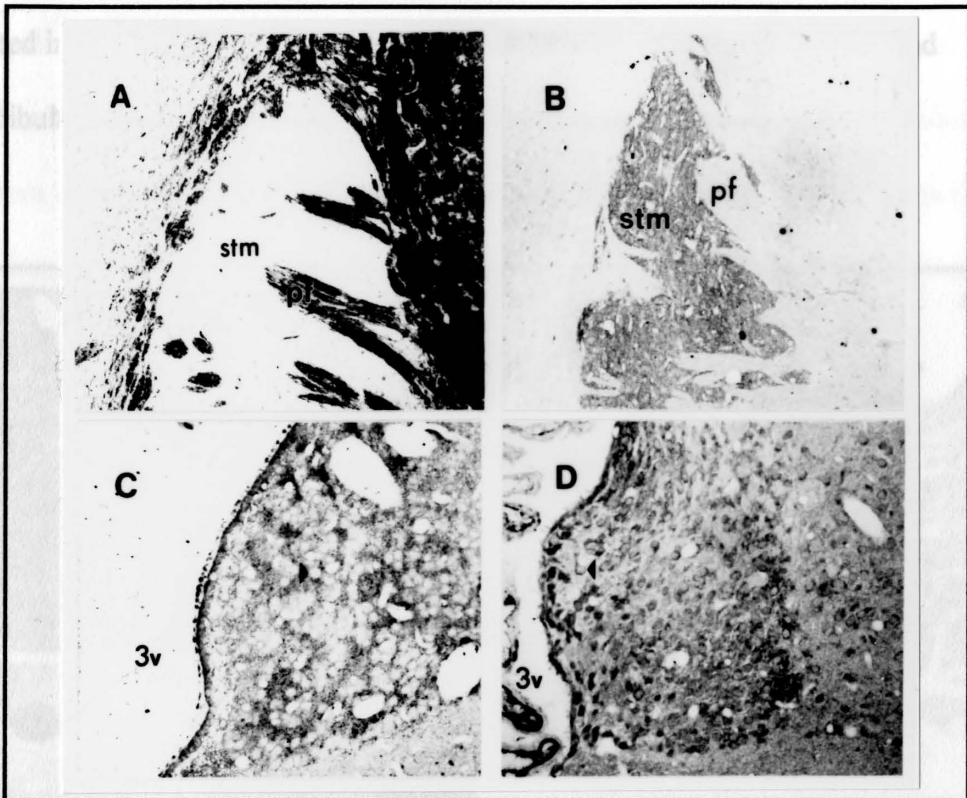

Figure 16. Photographs of G protein labeling in the striatum and habenula. **A:** $G_{i1 \text{ and } 2}$ labeling (intensified with silver) in the striatal pencil fibers (pf) and parenchyma (stm). X100. **B:** G_s labeling in the striatum. pf pencil fibers; stm, parenchyma X100. **C:** G_o labeling in the neuropil of the habenula. Note the immunonegative cell bodies (arrowhead). 3v, third ventricle. X25. **D:** Cytoplasmic G_s labeling of a cell (arrowhead) in the habenula. The third ventricle is indicated (3v). X25.

Figure 17. Photographs of G protein labeling in the thalamus, infundibular stem, and white matter fiber tracts. **A:** $G_{i1 \text{ and } 2}$ labeling (intensified with silver) in the ventral cytoplasm of cells in the VPT, LP, DLG, VLG nuclei, central medial thalamic nuclei, mediodorsal thalamic nuclei, and paraventricular thalamic nuclei.

Light to moderate G_o and $G_{i1 \text{ and } 2}$ -like immunoreactivity was observed in the hypothalamus and median eminence. Moderate to intense cytoplasmic G_s labeling was

detected in the hypothalamic tuberomammillary nucleus, median eminence, and infundibular stem (Figure 17B).

-like immunoreactivity was very intense in most of the forebrain white matter fiber tracts. The mammillothalamic (Figure 17C), fornix (Figure

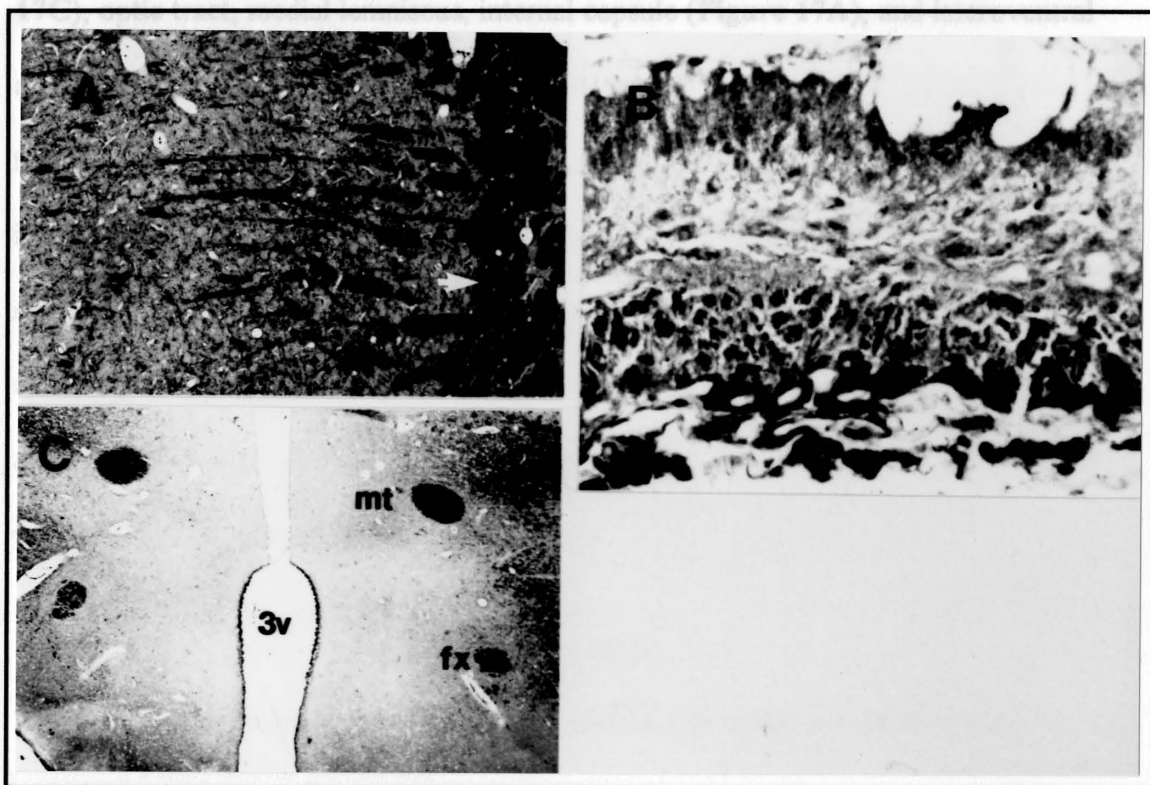

Figure 17. Photographs of G protein labeling in the thalamus, infundibular stem, and white matter fiber tracts. A: $G_{i1 \text{ and } 2}$ labeling (intensified with silver) in the ventral posterior thalamus. See figure 18 for orientation. Immunopositive white matter fibers of the internal capsule are indicated by a white arrow. X25. **B:** G_s labeling in the infundibular stem X200. **C:** $G_{i1 \text{ and } 2}$ labeling (in the mammillothalamic tract (mt) and fornix (fx). 3v, third ventricle. X25.

neuropil) but produced a very fibrous pattern throughout many brain areas. Cell bodies were immunonegative but the dendritic and axonal processes in certain brain areas were

Continued next page.

Fiber Tracts and Choroid Plexus

In general, the G_o and $G_{i1 \text{ and } 2}$ -like immunoreactivity was very intense in most of the forebrain white matter fiber tracts. The mammillothalamic (**Figure 17C**), fornix (**Figure 17C**), optic tract, medial lemniscus, internal capsule (**Figure 17A**), and lateroventral aspect of the external capsule were heavily labeled by the G_o and $G_{i1 \text{ and } 2}$ antibodies. The fasciculus retroflexus was the area with the heaviest labeling of G_o . G_s -like immunoreactivity was not readily found within white matter fiber tracts. In several sections, the fornix and mammillothalamic tract were actually lighter than the surrounding background (data not shown). The choroid plexus was labeled by all three antibodies and was the location of intense G_s staining. **Table 7** and **Figure 18** highlight the G protein labeling patterns.

Discussion

We compared the anatomical and intracellular distribution of the G proteins G_s , G_o and $G_{i1 \text{ and } 2}$ in the rat forebrain and our results suggest that the α -subunits of G_s , G_o and $G_{i1 \text{ and } 2}$ are differentially located both within neurons and among different brain areas. G_o was detected in the neuropil throughout all areas of the brain. Cell bodies and dendritic processes were often immunonegative. $G_{i1 \text{ and } 2}$ labeling was also located in the neuropil but produced a very fibrous pattern throughout many brain areas. Cell bodies were immunonegative but the dendritic and axonal processes in certain brain areas were

Table 7.--G protein like immunoreactivity in medial rat brain sections

Brain region	G _s	G _{i1 and 2}	G _o
Cortex			
layer 1	++ ^d	++ ^d	++++ ^d
middle and deep layers	+ ^c	+++ ^f	+++ ^d
entorhinal cortex	+++ ^d	+++ ^d	+++ ^d
corpus callosum (cc)	-	++	++
alveus (alv)	-	++++	++
cingulum (cg)	-	++++	++
Hippocampus			
CA1 pyramidal (Py)	++ ^c	-	-
oriens layer (Or)	+ ^d	++ ^d	+++ ^d
radiatum (Rad)	+ ^d	++ ^d	+++ ^d
CA2-4 pyramidal (Py)	+++ ^c	+++ ^f	-
oriens layer (Or)	+ ^d	+ ^d	++ ^d
radiatum (Rad)	+ ^d	+ ^d	++ ^d
dentate granular	++ ^d	-	-
Habenula	+++ ^c	+++ ^f	+++ ^d
Thalamus			
ventral posterior (VPT)	++ ^c	+++ ^f	+++ ^d
central medial (CM)	++ ^c	+ ^f	++ ^d
mediodorsal (MD)	++ ^c	+ ^f	++ ^d
paraventricular (Pv)	++ ^c	+ ^f	++ ^d
lateral post (LP)	++ ^c	++ ^f	++ ^d
dorsal (DLG) and ventral (VLG) lateral geniculate	-	++ ^f	+++ ^d
nucleus			
Hypothalamus			
tuberal nucleus (TMC)	++ ^c	+ ^d	+ ^d
dorsomedial (DM)	++ ^c	+ ^d	+ ^d
arcuate nucleus (Arc)	++ ^c	+ ^d	+ ^d
median eminence (ME)	++++	++	++
infundibular stem (InfS)	++++	++	++
Striatum parenchyma (stm)	+++ ^d	+ ^d	+ ^d
pencil fibers (pf)	-	++++	+++
optic tract (opt)	-	++++	+++

Continued next page

Table 7.-- Continued

Brain region	G _s	G _{il and 2}	G _o
Internal capsule (ic)	+	++++	+++
External capsule (ec)	-	+++	+++
mediodorsal	-	-	-
lateroventral	-	+++	+++
Medial lemniscus (ml)	+	++++	++
Fornix (fx)	+	++	++
Mammillothalamic tract (mt)	+	++	++
Choroid plexus (cp)	++++	++ to +++	++ to +++
Fasiculus retroflexus (fr)	-	+++	++++

Direct comparisons are made within a column. Indirect comparisons may be made between columns.

Key: negative -; light +; moderate, ++; intense +++; highest amount of staining, ++++.

^d diffuse neuropil

^f fibrous neuropil

^c cytoplasm.

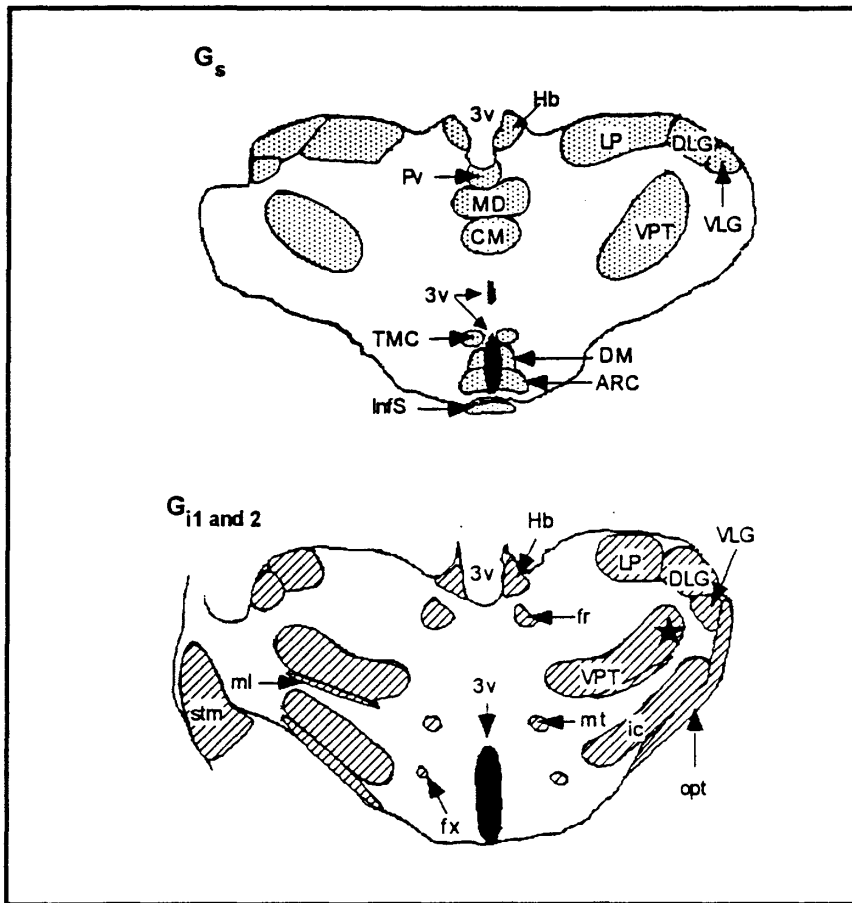

Figure 18. Camera lucida of G protein labeling in the subcortex. Cytoplasmic G_s labeling is indicated by dots in upper figure while G_{i1} and 2 neuropil and white matter fiber tract labeling is indicated by diagonal lines in the lower figure. A star marks the area of the photomicrograph in figure 17A. Abbreviations: ARC, hypothalamic arcuate nucleus; CM, thalamic central medial nucleus; DLG, thalamic dorsal lateral geniculate nucleus; DM, hypothalamic dorsal medial nucleus; fr, fasciculus retroflexus; fx, fornix; Hb, habenula; ic, internal capsule; InfS, infundibular stem; LP, thalamic lateral posterior nucleus; MD, thalamic mediodorsal nucleus; ml, medial lemniscus; mt, mammillothalamic tract; optic tract; Pv, thalamic paraventricular nucleus; stm, striatum; TMC, hypothalamic tuberal nucleus; VLG, thalamic ventral lateral geniculate nucleus; VPT, thalamic ventral posterior nucleus; 3v, third ventricle.

immunopositive. In contrast to G_o and $G_{i1 \text{ and } 2}$, G_s was detected primarily in the neuronal cytoplasm.

Cortex

In our investigation, the three different antibodies label the cortex with different intensities with $G_o > G_{i1 \text{ and } 2} > G_s$, consistent with quantitative Western blot studies (Saito *et al.*, 1989). The cortex is enriched with neurotransmitter receptors that couple to G_o , $G_{i1 \text{ and } 2}$, or G_s (McCormick, 1992). Our results show that G_o immunoreactivity in the cortex is located in the synaptic rich neuropil and is consistent with those reported by other investigators (Worley *et al.*, 1986; Asano *et al.*, 1987; Terashima *et al.*, 1988; Aoki *et al.*, 1992). Interestingly, we did not observe any G_o labeling within the perikarya as described by Aoki *et al.*, (1992) and Jordon (1990). There are a number of reasons for the discrepancy concerning the morphological location of G_o . Different antibody sources and immunohistochemical protocols were used in previous reports. Indeed, Aoki *et al.*, (1992) report that G_o labeling in the perikarya was observed only after higher dilutions of the primary antibody were used to decrease the signal in the neuropil.

Our detection of $G_{i1 \text{ and } 2}$ in the neuropil agrees with the observations of Asano *et al.*, (1990b) and Aoki *et al.*, (1992). However, we also detected $G_{i1 \text{ and } 2}$ in the fibers arising from the external capsule. The $G_{i1 \text{ and } 2}$ immunoreactivity may be located in a subset of cortical fibers since the antibody labeled discrete individual fibers.

There is very little information available from previous reports on the morphological location of G_s in cortical neurons. The low abundance of G_s in the central nervous system and antibody specificity contribute to the difficulty of analyzing the distribution of G_s using immunohistochemical techniques. However, we detected G_s in the cytoplasm of some cortical neurons. It is unlikely that our observations are due to a cross-reactivity with G_{olf} since a previous study reported that the cortex did not contain detectable levels of G_{olf} protein or mRNA (Hervé *et al.*, 1993).

Hippocampus

Our results generally agree with earlier investigations which established the location of G proteins in the hippocampus (Worley, *et al.*, 1986; Terashima *et al.*, 1988, 1993; Asano *et al.*, 1990b; Aoki *et al.*, 1992). In addition, we also report that the different G protein antibodies produced different labeling patterns within the same subfield. The differential labeling patterns may represent different synaptic locations for the G proteins. The patchy $G_{i1 \text{ and } 2}$ immunoreactivity concentrated near the perimeter of the pyramidal cell body in subfield CA3, suggests that the G proteins are located at terminals near the cell soma. A previous report by Aoki *et al.* (1992) described G_o and $G_{i1 \text{ and } 2}$ immunoreactivity within neuronal postsynaptic densities, axons, somata, and dendrites using electron microscopy. The contrasting locations of G_o (diffuse neuropil) and G_s (cytoplasm) is also very interesting. Different locations of the G proteins may reflect different synaptic locations but other factors may also contribute to the different labeling

patterns. Some of these factors include differences in cell function and G protein storage. Our results also extend into subfield CA3 where we observed different immunoreactive patterns when compared to subfield CA1. The different labeling patterns maybe due to differences in synaptic locations or differences in cell size or type.

The hippocampus contains several types of G protein-linked receptors. The 5-HT_{1A}, adenosine, and GABA_B receptors all couple to PTX-sensitive G proteins (i.e., G_o and G_i) (Andrade *et al.*, 1984; Zgombick *et al.*, 1989; Okuhara and Beck, 1994) but it is not known if these receptors couple to the same PTX-sensitive G protein. Our results suggest that if these receptors are located at different sites on the neuron, they may indeed couple to different PTX-sensitive G proteins.

The different labeling patterns for G_i and G_o in subfields CA1 and CA3 may provide an explanation for the differences in 5-HT concentration-response curves in the two subfields. In the hippocampus, 5-HT_{1A} receptor-activation increases an inward rectifying potassium current in both subfields CA1 (Andrade and Nicoll, 1987; Colino and Halliwell, 1987) and CA3 (Okuhara and Beck, 1994). However, 5-HT has a smaller maximal response and is more potent in subfield CA1 (Beck *et al.*, 1992). One possible explanation for this difference is that the 5-HT_{1A} receptor may couple to different G proteins in the two subfields. Both the 5-HT_{1A} receptor and G protein appear to be at different sites along the neuron in subfields CA1 and CA3. The 5-HT_{1A} receptor is closer to the cell body in subfield CA3 than in subfield CA1 (Pazos and Palacios, 1985).

Therefore, based on our observations, the 5-HT_{1A} receptor may couple to G_i in subfield CA3 and couple with either G_i or G_o in subfield CA1.

Striatum

The presence of all three G protein types in the striatum is not surprising since these nuclei contain many different G protein-linked receptors (Graybiel, 1990) along with mRNA for G_s and G_o (Brann *et al.*, 1987; Largent *et al.*, 1988). There is very little G_i mRNA in the striatum (Aronin and DiFiglia, 1992), suggesting that the G_{i1 and 2} immunoreactivity observed in the parenchyma in our study and in the study by Aronin and DiFiglia (1992) is located in the axon terminals. However, based on the detailed light and electron microscopic localization of G_i in the different basal ganglia structures (Aronin and DiFiglia, 1992) cytoplasmic labeling cannot be ruled out. While the immunohistochemical localization of the G proteins in the striatum is not a novel finding, there are several differences between our observations and previous reports. The G protein labeling pattern in our investigation and others (Worley *et al.*, 1986; Aronin and DiFiglia, 1992) does not resemble the patch-matrix distribution often observed in the striatum with antibodies against tyrosine hydroxylase or autoradiographic localization of μ -opiate receptor binding sites (Gerfen *et al.*, 1987). However, while the detection of G_o and G_{i1 and 2} in the striatal pencil fibers is the outstanding feature in our investigation, G_o and G_{i1 and 2} labeling in the parenchyma is the outstanding feature in previous reports (Worley *et al.*, 1986; Aronin and DiFiglia, 1992).

RM1 labeling in the striatum is difficult to interpret because this antibody cross-reacts with G_{olf} . Previous studies with the RM1 antibody (Cooper *et al.*, 1990; Drinnan *et al.*, 1991) report at least two immunoreactive bands on Western blots prepared with tissue from the striatum. One of these bands corresponds to G_{olf} based on immunological and mRNA analysis (Drinnan *et al.*, 1991; Hervé *et al.*, 1993). Our observations in the striatum with RM1 may reflect G_{olf} labeling since our labeling pattern resembles the one previously reported for G_{olf} (Hervé *et al.*, 1993). However, it is clear from our results that neither G_s nor G_{olf} is located with the striatal pencil fibers.

Thalamus

The homogeneous distribution of G_o throughout the different thalamic nuclei is in agreement with a previous study by Worley *et al.* (1986). However, the fibrous labeling pattern of $G_{i1 \text{ and } 2}$ in the neuropil is a novel finding. The thalamus contains a variety of neurotransmitter systems, including G protein-linked receptors, enabling it to function as a relay between the cortex and several sensory systems (McCormick, 1992). The moderate to intense presence of both $G_{i1 \text{ and } 2}$ and G_o in the ventral posterior thalamic nuclei, medial lemniscus, and internal capsule suggest that these G proteins have important roles in conveying somatosensory signals. The ventral posterior nuclei relay somatosensory information from the dorsal column-medial lemniscal system to the somatosensory cortex via the posterior limb of the internal capsule. The geniculate nucleus also contains neurotransmitter receptors that link to G proteins (Matute *et al.*,

1993). The moderate to intense $G_{i1\text{and}2}$ and G_o immunoreactivity in the optic tract and lateral geniculate nuclei suggests that these G proteins may also have important roles in conveying visual signals.

Hypothalamus

In our study we demonstrate that the G proteins are differentially localized in cells of the hypothalamus, median eminence, and arcuate nucleus. Our results are consistent with previous mRNA and Western blot analysis detecting G protein expression in the hypothalamus (Largent *et al.*, 1988; Viollet *et al.*, 1994). The detection of PTX-sensitive G proteins G_i and G_o in the median eminence and infundibular stem coincide with the presence of 5-HT₁ (Biegon *et al.*, 1982) and melatonin receptors (Vanecek *et al.*, 1987; Lopez-Gonzalez *et al.*, 1991), two receptors which couple to PTX-sensitive G proteins (Andrade *et al.*, 1986; Reppert *et al.*, 1994). The detection of G_i and G_o immunoreactivity in the median eminence and infundibular stem suggests that these G proteins may be important in the secretions of hormones at these sites.

The release of growth hormone-releasing hormone and dopamine by the parvocellular neurons in the arcuate nucleus is regulated by G protein-linked neurotransmitter receptors. For example, growth hormone-releasing hormone and the somatostatin receptor have been shown to colocalize within the same neurons in the arcuate nucleus (Bertherat *et al.*, 1992; McCarthy *et al.*, 1992). The detection of G_s ,

$G_{i1 \text{ and } 2}$, and G_o in the arcuate nucleus supports the observations that G protein-linked receptors play a role in hormone secretion in the hypothalamus (reviewed by Renaud *et al.*, 1992; Liposits, 1993).

Very little is known about the function of the tuberomamillary nucleus and the types of neurotransmitter receptors located in the nucleus. However, our detection of G proteins in the tuberomamillary nucleus suggests that these neurons may contain neurotransmitter receptors that link to G proteins and may also help to explain the nucleus' role in Alzheimer's disease. The tuberomamillary nucleus projects to the cerebral cortex and is severely affected in Alzheimer's and Parkinson's disease (Braak and Braak, 1992). Furthermore, G protein and neurotransmitter receptor coupling are attenuated in cortical tissue isolated from Alzheimer's disease patients (Warpman *et al.*, 1993; Wang and Friedman, 1994). Therefore, altered coupling between neurotransmitter receptors and G proteins in the tuberomamillary nucleus may contribute to some of the symptoms observed in patients with Alzheimer's disease.

Fiber Tracts and Choroid Plexus

Our novel detection of G proteins within white matter fiber tracts should be interpreted cautiously, especially since previous immunohistochemical studies have not described the labeling of G proteins in white matter fiber tracts. It is unlikely that our detection of G_o and $G_{i1 \text{ and } 2}$ is due to nonspecific labeling since the labeling intensity and distribution were different in at least three tracts: the alveus, hippocampal fissure, and the

dorsomedial and lateroventral aspects of the external capsule. Furthermore, we also observed white matter fiber tract labeling using a different immunohistochemical protocol utilizing a substantially lower antibody concentration.

Since the G proteins are located at axon terminals (Aoki *et al.*, 1992; Aronin and DiFiglia, 1992), G protein immunoreactivity within fiber tracts may be due to axonal transport of the proteins (Hendry and Crouch, 1991; Crouch *et al.*, 1994). The presence of G protein immunoreactivity may also be due to the labeling of G proteins in oligodendrocytes. Indeed, neurotransmitter receptors have been detected in glial cells (reviewed by Ransom and Sontheimer, 1992; Chiu and Kriegler, 1994). It is clear from our investigation and previous reports that the G proteins are located and serve functions at sites beyond the synapse.

All three antibodies labeled the choroid plexus and this was the area of intense G_s immunoreactivity. The presence of G_o in the choroid was previously described by Péraldi *et al.* (1989) where it was detected at the apical pole of choroidal ependymocytes. The distribution of G proteins, Na-K-ATPase (Ernst *et al.*, 1986), neurotransmitter receptors (Yagaloff and Hartig, 1985; Conn *et al.*, 1986), and other ion channels in the choroid plexus suggests that the function of the choroid may be modulated by molecules in the cerebral spinal fluid or neuronal innervation (Péraldi *et al.*, 1989).

Concluding remarks

The differential distribution of G proteins and neurotransmitter receptors within neurons and in different brain areas may contribute to the coupling specificity between the receptors and G proteins. In our investigation, we observed that the G proteins G_s , G_o and $G_{i1 \text{ and } 2}$ are distributed differently within the rat forebrain. We also observed differences in the intraneuronal labeling patterns between the G proteins. G_s labeling was observed in the cytoplasm while G_o and $G_{i1 \text{ and } 2}$ labeling was located in the neuropil. G_o and $G_{i1 \text{ and } 2}$ labeling in the neuropil also produced different patterns. G_o labeling was diffuse while $G_{i1 \text{ and } 2}$ labeling was fibrous. The differences in G protein labeling patterns between brain areas and in neurons suggests that unique synaptic organizations may exist between the different brain nuclei. For example, certain brain areas may contain a high concentration of dendrodendritic synapses while other areas are characterized by dendrosomatic synapses. Unique synaptic organizations may also exist among different cell types. The colocalization of receptor and G proteins may be different between a mossy fiber and pyramidal cell synapse when compared to one between a basket cell and pyramidal cell. In order to determine if unique synaptic organizations do exist among the different brain areas, the brain nuclei in which differential labeling patterns for the G proteins were observed (i.e., hypothalamus, white matter fiber tracts, and habenula) should be analyzed, in detail, at the electron microscopic level.

CHAPTER VI

CORTICOSTERONE ALTERS G PROTEIN α -SUBUNIT LEVELS IN THE RAT HIPPOCAMPUS.

Abstract

The HPA axis regulates the synthesis and secretion of glucocorticoid steroid hormones. The hippocampus, a component of the limbic system, contains the highest concentration of corticosteroid receptors in the brain and may play an important role in regulating hypothalamic-pituitary-adrenal axis activity and mediating physiological responses to stress. In Chapter IV, it was concluded that corticosterone treatment alters the 5-HT_{1A} receptor signal transduction system at sites downstream of the receptor. The 5-HT_{1A} receptor couples to a PTX-sensitive G protein, therefore, corticosteroids may influence G protein levels and/or their intracellular location. The glucocorticoid corticosterone alters the response elicited by activation of several different G protein-linked neurotransmitter receptors in the hippocampus. In the present study we used Western blot and immunohistochemical techniques to determine the effects of chronic adrenalectomy (ADX), low (CT) and high (HCT) plasma corticosterone concentrations on G_s, G_{i1 and 2} and G_o α -subunit levels and intracellular location in the rat hippocampus.

CT treatment increased G_s α -subunit levels and HCT treatment increased the levels of G_s , G_{i1} and G_{i2} and G_o α -subunits when compared to sham as detected on Western blots. No change in the intracellular location of the G protein α -subunits was detected using immunohistochemistry. Based on our results, we conclude that corticosterone alters G protein α -subunit levels in the rat hippocampus without altering their intracellular location. These results provide an important piece of information towards understanding how glucocorticoids alter G protein-linked neurotransmitter responses.

Introduction

Glucocorticoids directly influence protein expression by binding to intracellular steroid receptors designated as MR and GR. In rats, the two corticosteroid receptors have different affinities for the glucocorticoid corticosterone (Corini *et al.*, 1985; Reul and de Kloet, 1985). MR binds to corticosterone with a $K_D = 0.5$ nM. GR has a lower affinity for corticosterone with a $K_D = 2.5 - 5$ nM. The corticosteroid receptors in humans and other primates have affinities for corticosterone that are similar to rats (Tsuboi *et al.*, 1979; Yu *et al.*, 1981; Brooke *et al.*, 1994). The hippocampus contains the highest concentration of corticosteroid receptors in the central nervous system (McEwen *et al.*, 1968; Gerlach and McEwen, 1972; Maraginos *et al.*, 1990) consequently, the function of corticosteroid receptors in the hippocampus is under intense investigation (review by de Kloet *et al.*, 1993; Joëls and de Kloet, 1994).

Corticosterone alters the response elicited by the activation of several different G protein-linked neurotransmitter receptors. For example, in the rat hippocampus, corticosterone alters the responses elicited by activation of 5-HT_{1A} receptors linked to G_i/G_o (Joëls *et al.*, 1991; Joëls and de Kloet, 1992; Beck *et al.*, 1996) and 5-HT₄ (Birnsteil and Beck, 1995) and β -adrenergic receptors linked to G_s (Roberts *et al.*, 1984; Harrelson *et al.*, 1987; Joëls *et al.*, 1989; Gannon and McEwen, 1990). In Chapter IV it was concluded that corticosteroids also alter the response elicited by activation of 5-HT_{1A} receptors in hippocampal subfield CA3. The mechanism by which glucocorticoids alter the G protein-linked neurotransmitter receptor responses is not completely known and is currently under investigation. Depending on the receptor system, glucocorticoids may alter the receptor, G protein, and/or effector molecules. For example, in the rat brain glucocorticoids alter dopamine D1 and D2 (Biron *et al.*, 1992) and serotonin 5-HT_{2C} (Holmes *et al.*, 1995a,b) receptor mRNA levels, β -adrenergic receptor binding levels (Roberts and Bloom, 1981), and 5-HT_{1A} receptor binding and mRNA levels (reviewed by Chaouloff, 1995). Glucocorticoids also modulate effector molecule function and expression. For example, glucocorticoids alter adenylyl cyclase activity and mRNA levels (Gannon *et al.*, 1994; Wolfgang *et al.*, 1995) in the rat hippocampus.

In addition to the changes in neurotransmitter receptor levels and effector molecule activity, glucocorticoids may also alter G protein expression or activity. The regulation of G protein levels by glucocorticoids has been examined in several tissue types including

liver (Kawai and Arinze, 1993), aorta (Haigh *et al.*, 1990), fetal forebrain tissue (Slotkin *et al.*, 1994), and vascular smooth muscle (Schelling *et al.*, 1994). However, there is little information on the effects of corticosterone on G protein expression and function in the hippocampus. In Chapter IV it was concluded that corticosteroids altered the outward current evoked by the activation of G proteins with GTP γ S. Changes in G protein function may reflect changes in protein levels and/or intracellular location, altering the interaction between specific receptor-G protein-effector molecule complexes. Therefore, in the present study, we used Western blotting and immunohistochemical techniques to determine the effects of corticosterone on G protein α -subunit levels and distribution in the hippocampus.

Materials And Methods

Materials

Corticosterone pellets were purchased from Innovative Research of America (Sarasota, FL). G protein α -subunit polyclonal antibodies RM1 (G_s), AS7, (G_{i1} and 2), and GC2 (G_o) were purchased from Dupont-New England Nuclear (Wilmington, DE). Monoclonal rabbit peroxidase-antiperoxidase antibody was purchased from Cappel (Durham, NC). Picric acid was purchased from Aldrich (Milwaukee, WI). 3,3'-diaminobenzidine tetrachloride (DAB) was purchased from Sigma (St. Louis, MO). All other chemicals were obtained from commercial sources.

Animals

Male Sprague-Dawley rats (75-100 g; Harlan) were maintained on a twelve hour light-dark cycle (7 a.m. to 7 p.m. light on). Bilateral adrenalectomies (ADX) were performed under ether anesthesia. An incision was made just below the rib cage and the adrenal gland removed. The muscle wall was then sutured and the skin closed using wound clips. To predominately activate MR and mimic basal levels of plasma corticosterone, one group of animals (CT) received a subcutaneous 12.5 mg corticosterone pellet. To activate both MR and GR, another group of animals (HCT) received 300 mg corticosterone pellets subcutaneously. A sham group of animals was produced by visualizing the adrenal glands but leaving them intact. Following surgery, all animals were given standard laboratory chow *ad libitum*. SHAM animals were given standard drinking water while the ADX, CT, and HCT animals were given 0.9 % NaCl drinking water *ad libitum*. All animals were sacrificed 2 weeks after surgery. Sacrifices occurred before 12:00 noon and blood samples were collected at that time to determine plasma corticosterone levels (Burgess and Handa, 1992).

Membrane Preparation

Membrane proteins were isolated from hippocampal tissue using a procedure described elsewhere (Sternweis and Robinshaw, 1984; Okuhara *et al.*, 1996c). Protein isolation procedures were carried out at 4°C. Briefly, the animals were decapitated and the hippocampus dissected free. The hippocampus was homogenized with a hand-held

dounce homogenizer in TBS (10 mM Tris, pH 7.6 and 150 mM NaCl), 10% sucrose, and 0.5 mM phenylmethanesulfonyl fluoride. The homogenate was then centrifuged at 20,000 X g for 30 min. The supernatant was removed and the membrane pellet was resuspended in a second identical wash and centrifuged again at 20,000 X g for 30 min. The supernatant was removed and the membrane pellet was resuspended in TBS, 1 mM EDTA and 1% sodium cholate and incubated for 60 min with constant mixing. The supernatant containing the soluble membrane protein was separated by centrifugation at 35,000 rpm for 60 min and stored at -80 °C.

Western Blot Analysis

Western blotting techniques used in this investigation are described elsewhere (Lesch and Manji, 1992). Briefly, membrane proteins (6 µg) were resolved by SDS-PAGE and electrophoretically transferred to nitrocellulose membrane filters. Equal loading of protein samples was verified by staining a parallel polyacrylamide gel with Coomassie blue. After transfer, the nitrocellulose was incubated in TBS, 0.2% NP-40, and 5% nonfat dry milk at room temperature to block non-specific binding. After 60 min the nitrocellulose was incubated with a 1/10,000 dilution of AS7, RM1, or GC2 overnight at 4°C. The nitrocellulose was then incubated with a 1/10,000 dilution of goat anti-rabbit IgG for 60 min at room temperature followed by an incubation with 1/10,000 dilution of rabbit PAP. The blots were developed with the ECL chemiluminiscent

detection kit (Amersham, Arlington Heights, IL) and exposed to x-ray film. All antibody dilutions were in TBS, 5% BSA, and 0.2% NP-40. The nitrocellulose filter was washed with TBS/0.2% NP-40 between every antibody incubation and prior to development with the ECL kit.

The optical density and area of the G protein bands were obtained using the NIH Image analysis program. Gray scale density readings were calibrated using a transmission step wedge standard fitted to the Rodbard equation. An integrated optical density (IOD) was calculated by summing the optical densities within the area of a band. To determine the IOD of the G protein bands, the bands were outlined three times and the mean IOD was calculated. An area adjacent to the G protein band was used to calculate the background optical density of the film and was subtracted from the integrated optical density of the G protein band. The linear range of the XAR film was determined by including a range of hippocampal protein (0.5 to 3 fold) in each Western blot. Five animals were used for each treatment group. Western blot experiments were repeated three times for each antibody. Each blot contained tissue samples from SHAM and either ADX, CT, and HCT treated animals, therefore, the IOD values for the ADX, CT, and HCT groups were standardized to their respective SHAM values and reported as % change from SHAM (SHAM = 0%). The results from three Western blot experiments were averaged and a two-way analysis of variance was performed using ADX, CT, and HCT treatment as one factor and G protein α -subunit as another factor. The Student-

Newman-Keuls method was used as the post-hoc test. To compare the effects of ADX, CT, or HCT directly to the effects of SHAM treatment, the IOD of the G protein bands on each Western blot were compared using a Student's *t*-test.

Immunohistochemical Procedure

The animals were sacrificed with a lethal injection of phenobarbital and perfused with 200 ml PBS (10 mM NaHPO₄, pH 7.4, and 150 mM NaCl) *via* the aorta at 650 ml/h, followed by 250 ml PA fixative (4% paraformaldehyde, 1% glutaraldehyde, 0.2% picric acid, 2% sucrose, 0.1 M acetate buffer, pH 6.0) as described previously (Asano *et al.*, 1990; Okuhara *et al.*, 1996c). After fixation, the brain was removed, blocked, and placed in PA for 4-6 h. After rinsing and overnight incubation in TBS/10% sucrose, the tissue was embedded in paraffin, sectioned at 7 μ m, and mounted on microscope slides.

Immunohistochemical labeling of G_s and G_o α -subunits was performed following protocols described by Sternberger *et al.*, (1970). Briefly, tissue sections were blocked with TBS/5% bovine serum albumin (BSA)/3% normal goat serum (NGS) for 1 hour at room temperature. After washing the sections with TBS, three times for 10 min each, they were incubated with RM1 diluted 1:50 or GC2 diluted 1:100 overnight at room temperature. Several sections were incubated with 2% NGS in place of primary antibody to determine the level of nonspecific labeling. Sections were then washed with TBS, three times for 10 min each, and incubated with goat anti-rabbit IgG diluted 1:20.

After 1 h, sections were washed with TBS and incubated with rabbit peroxidase-antiperoxidase for 1 h. All antibody dilutions were made in TBS/5% BSA/3% NGS. Immunohistochemical labeling of G_{i1} and 2α -subunits was performed with the Vectastain *Elite* kit (Vector Laboratories, Inc., Burlingame, CA). Briefly, after blocking with NGS, tissue sections were incubated overnight with AS7 diluted 1:400. All sections were washed in TBS and developed with hydrogen peroxide and DAB as the chromagen.

Each immunohistochemistry experiment was repeated once and analyzed independently without knowledge of the treatment. The location of the antibody label within the dorsal hippocampus was recorded for each slide. Three animals were used for each treatment group.

Results

Corticosterone Plasma Levels

The mean plasma corticosterone levels were (mean \pm SD, n=3): 3.2 ± 4.2 μ g/dl for SHAM, 0 ± 0 for ADX, 3.1 ± 1.5 for CT, and 25.1 ± 6.4 for HCT. These corticosterone levels are comparable to those reported previously by our laboratory (Beck *et al.*, 1994; 1996; Birnstiel and Beck 1995) and other investigators (Reul and de Kloet, 1985; Holmes *et al.*, 1995a).

Western Blots

On Western blots prepared with the membrane fraction from hippocampal tissue, antibodies labeled the appropriate size bands (Okuhara *et al.*, 1996c). The RM1 antibody labeled a 45 kDa and 54 kDa protein (**Figure 19A**) corresponding to the short and long forms of the G_s α -subunit (Bray *et al.*, 1986; Robinshaw *et al.*, 1986; Kozasa *et al.*, 1988). Detection of the 54 kDa band was inconsistent. When the band was detected, it was a faint and indistinct. The AS7 and GC2 antibodies labeled a 40 kDa band (**Figure 19A**) corresponding to the appropriate size bands for $G_{i1 \text{ and } 2}$ and G_o α -subunits respectively (Goldsmith *et al.*, 1987; Cooper *et al.*, 1990).

The coefficient of variation (standard deviation \div mean) for the SHAM IOD values were calculated for each antibody to determine the variability in the control data. The mean coefficient of variation (mean \pm S.E.M, $n = 9$ for all antibodies) was 0.20 ± 0.05 , 0.15 ± 0.01 , and 0.14 ± 0.02 for the AS7, GC2, and RM1 antibodies respectively.

A two-way analysis of variance of the data indicated that corticosterone treatment produced a significant effect ($F = 11.3$, $P < 0.001$) on G protein α -subunit levels. The percent change in G protein α -subunit levels relative to SHAM was greater in tissue from HCT treated animals compared to ADX ($q = 6.390$, $p < 0.05$) and CT ($q = 5.037$, $p < 0.05$) based on Student-Newman-Keuls post hoc tests. In comparison to the SHAM group, ADX treatment did not alter the levels of G_s , $G_{i1 \text{ and } 2}$ and G_o α -subunits. CT treatment only increased G_s α -subunit levels. HCT treatment increased the levels of G_s ,

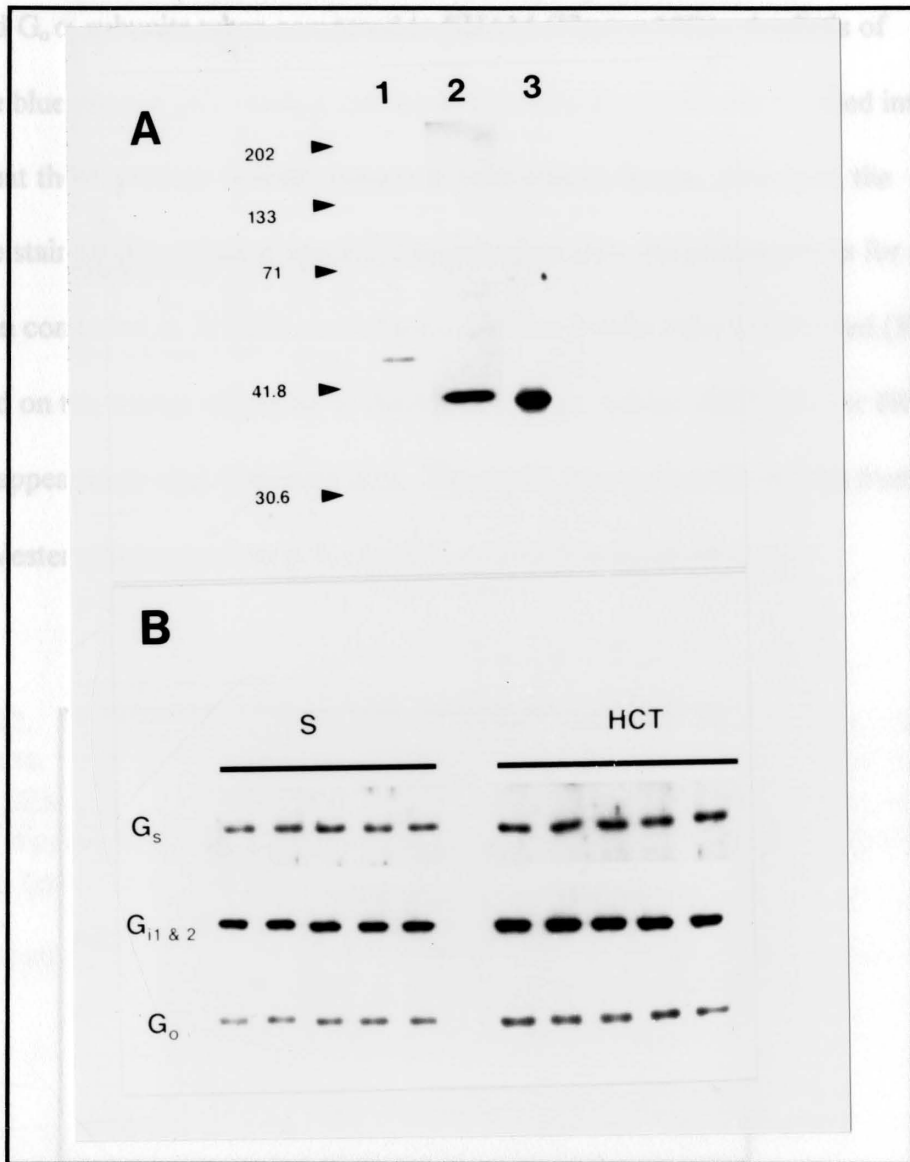

FIGURE 19. Western blots of G protein α -subunits prepared from hippocampal membrane fractions. A: Antibody labeling of G protein α -subunits. Lane 1, anti- G_s (RM1). Lane 2, anti- $G_{i1 \& 2}$ (AS7). Lane 3, anti- G_o (GC2). **B:** Antibody labeling of G protein α -subunits isolated from five SHAM (S) and five HCT (HCT) animals. G protein α -subunit subtype is indicated on the left.

$G_{i1 \text{ and } 2}$ and G_o α -subunits when compared to SHAM (**Figure 19B**). Analysis of Coomassie blue stained gels verified that equal amounts of protein were loaded into each lane and that there were no overall changes in total protein levels. However, the Coomassie stained gels revealed that HCT appeared to alter the protein levels for several bands when compared to SHAM; some bands increased while others decreased (**Figure 20**). Based on the similar migration of the labeled bands, neither ADX, CT, or HCT treatment appeared to alter G protein size. **Figure 21** summarizes the results from three different Western blot experiments for each G protein α -subunit antibody.

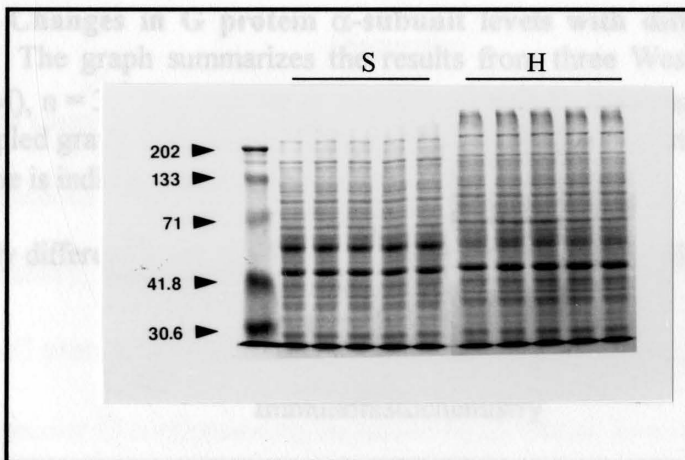

Figure 20. Coomassie blue stained gel of tissue samples used for Western Blots. A SDS-PAGE gel was prepared identically as in figure 19 and stained with Coomassie blue. S, SHAM; H, HCT. Molecular weight markers are in the first lane on the left.

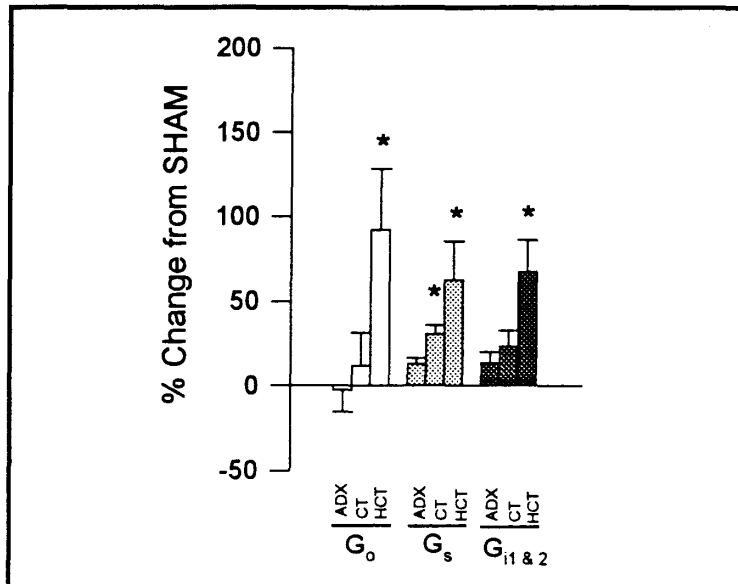

Figure 21. Changes in G protein α -subunit levels with different corticosterone treatments. The graph summarizes the results from three Western blot experiments (mean \pm SEM), $n = 3$. The bars are grouped by G protein α -subunit subtype; G_o (open), G_s (light stippled gray), and $G_{i1 \text{ and } 2}$ (dark stippled gray). Treatment group and G protein α -subunit type is indicated along the x-axis.

* Significantly different from SHAM, Students t -test, $P < 0.05$. SHAM is 0%.

Immunohistochemistry

While Western blot analysis can be used to detect a change in G protein levels, changes in the location of G protein α -subunits within specific areas of the hippocampus or in specific locations within neurons cannot be determined. Therefore, we used immunohistochemistry techniques to address these questions. As reported previously, the labeling pattern for the G protein α -subunits varied across subfields and among the

different G proteins examined (Okuhara *et al.*, 1996c). G_s α -subunit labeling was located in the cytosol of the soma in hippocampal subfields CA1-CA4 (**Figure 22B**). In contrast to G_s , the labeling of G_o α -subunits was located in the neuropil in subfields CA1-CA4 (**Figure 22D**) and dentate gyrus (**Figure 22F**). $G_{i1 \text{ and } 2}$ α -subunits labeling was equally intense in the soma cytosol and neuropil. In control tissue sections, where the primary antibody was omitted, nonspecific labeling was very faint and distributed evenly throughout the entire tissue section (data not shown). The distribution of the G proteins among the various hippocampal subfields and their location within neurons was not altered in any treatment group.

Discussion

G proteins couple plasma membrane receptors to intracellular effector molecules to transduce extracellular signals into biochemical and physiological changes within a cell. In the present study, we examined the effects of several chronic corticosterone treatments on G protein α -subunit levels and distribution in the hippocampus. Chronic basal concentrations of corticosterone increased G_s α -subunit levels while higher concentrations of corticosterone increased the α -subunit levels of G_s , $G_{i1 \text{ and } 2}$ and G_o as determined by Western blot analysis. None of the corticosterone treatments altered the intracellular location of G proteins based on our immunohistochemistry results.

Figure 22. Immunohistochemical labeling of G protein α -subunits and cresyl violet staining of nissel bodies in the hippocampus. B: G_i labeling in subfield CA3 in sections from a SHAM animal. X200. Or, oriens layer; Py, pyramidal layer; rad, radiatum layer. **D:** Cytoplasmic labeling of G_i in a pyramidal cell (arrow head). Or, oriens layer; Py, pyramidal layer; rad, radiatum layer. G_o labeling in subfield CA1 in sections from a SHAM animal. X200. **F:** G_o labeling in the dentate gyrus in sections from a ADX animal. X100. g, granular layer. Panels **A**, **C**, and **E** are photomicrographs of cresyl violet stained nissel bodies from similar tissue sections of subfields CA3, CA1, and dentate gyrus respectively.

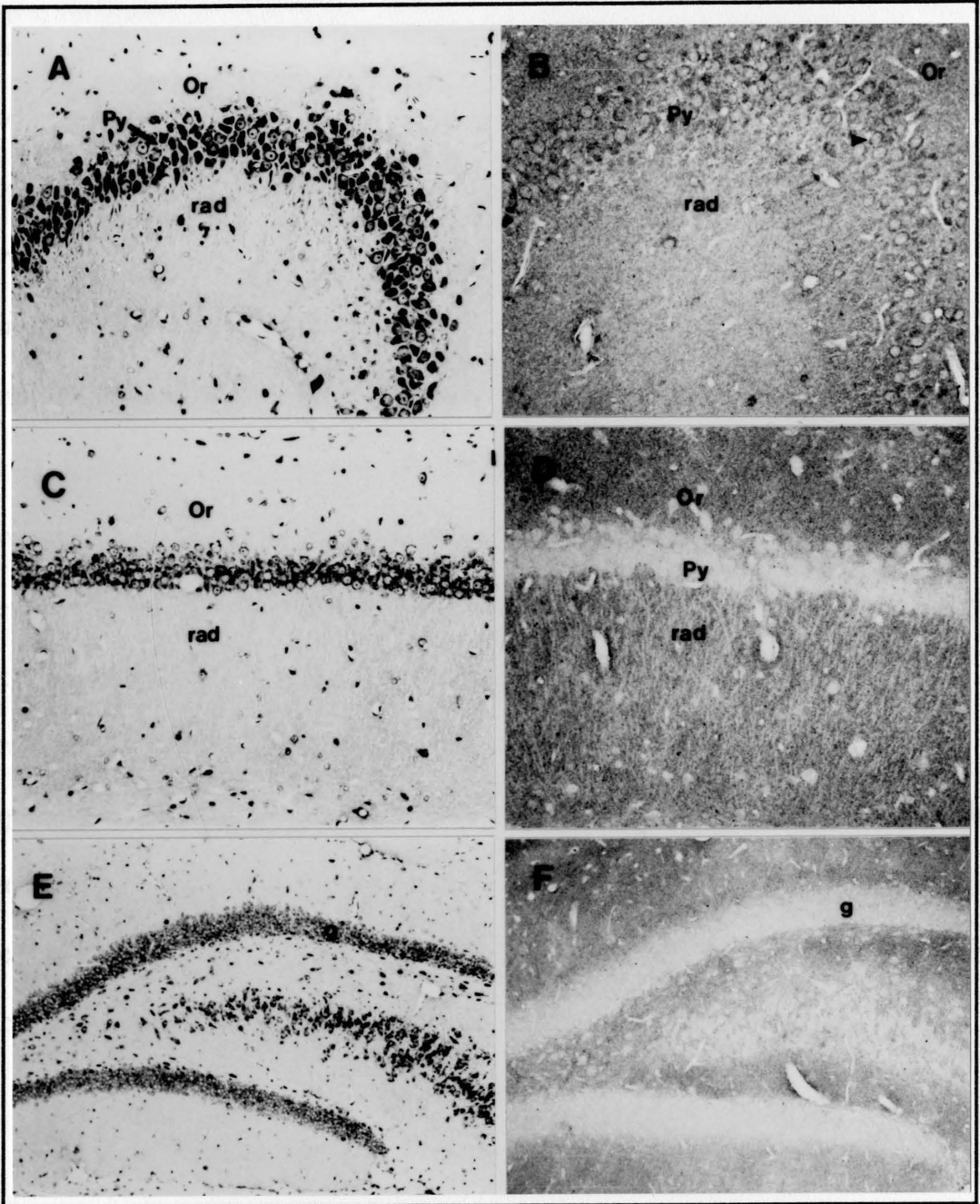

tissue with various results. Adrenomedullary deafferentation led to increased G₁ α-subunit

Adrenalectomy had no effect on G protein α -subunit levels or distribution. Two other studies examined the effects of corticosterone on G protein α -subunit levels in the hippocampus. The increase in G_s and G_o α -subunit levels that we observed with high corticosterone concentrations was also reported by Wolfgang *et al.*, (1995) using animals subjected to restraint stress. Gannon *et al.*, (1994) reported that neither adrenalectomy nor corticosterone treatment altered the levels of G_s or G_i α -subunits in the hippocampus. We also observed no change in the α -subunit levels of G_{i1} and 2 with adrenalectomy or basal concentrations of corticosterone. We did detect an increase in the α -subunit levels of G_s with basal corticosterone concentrations and this increase may not have been detected by Gannon due to important differences in the treatment paradigms. In Gannon's study, the animals were sacrificed at the peak of the diurnal surge when both MR and GR are occupied in the sham animals. In contrast, our animals were sacrificed during the trough of the diurnal surge when only a small fraction of GR is occupied. The time of sacrifice maybe a very important experimental parameter to take into account since both GR and MR mRNA levels show circadian variation (Holmes *et al.*, 19995a).

The effects of glucocorticoids on G protein expression have been examined in other tissue with various results. Adrenalectomy decreased G_i and increased G_s α -subunit

levels in the rat aorta when compared to sham (Haigh *et al.*, 1990). In the cerebral cortex, corticosterone replacement decreased G_i and increased G_s α -subunit levels when compared to adrenalectomy (Saito *et al.*, 1989). Finally, in the liver, dexamethasone (which selectively activates GR) increased the α -subunit levels of both G_s and G_i (Kawai and Arinze, (1993). It is clear from the various effects of glucocorticoids on G protein levels in different tissue types that the effects of glucocorticoids are tissue specific.

Examining the effects of glucocorticoids on G protein levels may help to determine the mechanism by which glucocorticoids modulate the responses associated with different G protein-linked neurotransmitter receptors. For example, it is known that glucocorticoids modulate neurotransmitter stimulated cAMP accumulation in both periphery and central nervous systems (reviewed by Harrelson and McEwen, 1987). For example, adrenalectomy increases NA stimulated cAMP accumulation in the limbic forebrain and frontal cortex (Mobley and Sulser, 1980a,b). Adrenalectomy also increased cAMP accumulation in response to vasoactive intestinal peptide but decreased the same response to histamine (Harrelson *et al.*, 1987). In the hippocampus, adrenalectomy increased the NA stimulated cAMP accumulation (Roberts *et al.*, 1984; Harrelson *et al.*, 1987) without altering β -adrenergic receptor binding (Roberts *et al.*, 1984) or forskolin-stimulated adenylyl cyclase activity (Mobley *et al.*, 1983; Harrelson *et al.*, 1987; Gannon and McEwen, 1990). The administration of corticosterone reversed the effects of adrenalectomy in the hippocampus (Roberts *et al.*, 1984) and cortex (Mobley *et al.*,

1983) while even higher levels of corticosterone attenuated the NA response below control levels in the hippocampus (Gannon and McEwen, 1990). We observed no change in G protein α -subunit levels with ADX. Therefore, the glucocorticoid-induced effects on NA stimulated cAMP accumulation are not occurring by directly altering neurotransmitter receptor binding or G protein levels. Adrenalectomy may be altering the coupling between signal transduction components.

Unlike the noradrenergic receptors, several studies have shown that glucocorticoids modulate 5-HT_{1A} receptor expression in the hippocampus. Despite some conflict on the effects of glucocorticoids among the various subfields (reviewed by Chaouloff, 1995), adrenalectomy appears to increase 5-HT_{1A} receptor binding (Mendelsohn and McEwen, 1992a,b; Chalmers *et al.*, 1993; Kuroda *et al.*, 1994; Tejani-Butt and Lablow, 1994; Zhong and Ciaranello, 1995) and mRNA levels (Chalmers *et al.*, 1993; Meijer and de Kloet, 1994; Zhong and Ciaranello, 1995). The effects of adrenalectomy on 5-HT_{1A} expression and binding is reversed with corticosterone.

In the present study, ADX did not alter the α -subunit levels of G_i and G_o, the G proteins probably linked to the 5-HT_{1A} receptor in subfield CA3 (Okuhara *et al.*, 1994). Therefore, neither the smaller EC₅₀ value nor the larger GTP γ S evoked current observed in cells from ADX treated animals reported in Chapter IV is due to changes in G_i or G_o α -subunit levels. Furthermore, the HCT-induced increase in G_i or G_o α -subunit levels observed in the present investigation also does not account for the larger EC₅₀

value or smaller GTP γ S evoked current observed in cells from HCT treated animals reported in Chapter IV. The increase in G protein α -subunit levels may be a compensatory response to changes in the receptor signal transduction system. Therefore, corticosteroids may be altering the 5-HT_{1A} receptor signal transduction system by modulating the kinetic properties of the potassium channel linked to the receptor, coupling between the G protein and potassium channel, or G protein activity.

There are several reasons why changes in G protein levels and neurotransmitter receptor responses may not coincide. Neurotransmitter receptors, G proteins, and effector molecules are all targets for post-translational modifications, such as phosphorylation (Bushfield *et al.*, 1990; Akiho *et al.*, 1993; Girault, 1993; Yamane and Fung, 1993; Levitan, 1994; Morris *et al.*, 1994; Siegelbaum, 1994; Levistre *et al.*, 1995; Neer, 1995; Pfeifer *et al.*, 1995; Premont *et al.*, 1995). Post-translational modifications may alter the coupling of receptor, G proteins, and effector molecules and therefore their ability to function (reviewed by Girault, 1993; Yamane and Fung, 1993; Levitan, 1994; Siegelbaum, 1994; Neer, 1995; Premont *et al.*, 1995). Future studies will address issues of the phosphorylation state of the G protein signal transduction components.

Another reason why it is difficult to correlate changes in G protein levels with changes in receptor-mediated responses is the potential interaction of the different G protein subunits and effector molecules. It is clear the $\beta\gamma$ -subunits as well as

α -subunits modulate the activity of the various adenylyl cyclase isoforms (reviewed by Birnbaumer and Birnbaumer, 1995) and ion channel activity (Kofuji *et al.*, 1995).

Although glucocorticoids do regulate β -subunit levels in the rat aorta (Haigh *et al.*, 1990), adipocytes (Ros *et al.*, 1989), and liver (Kawai and Arinze, 1993), they do not regulate β -subunit expression in the rat cortex (Saito *et al.*, 1989). Glucocorticoid effects on $\beta\gamma$ -subunits in the hippocampus are not known.

In conclusion, G proteins are associated with a large number of biochemical and physiological processes including hormone, neurotransmitter, and growth factor receptor mediated responses. The steroid hormone corticosterone alters the responses of neurotransmitter receptors which are linked to G proteins. In the present study, high concentrations of corticosterone increased the G protein α -subunit levels of G_s , G_o , and $G_{i1\text{and }2}$ in the hippocampus. Our results provide important information towards understanding how corticosterone modulates neurotransmitter receptor-mediated responses in the hippocampus.

CHAPTER VII

DISCUSSION

Major Findings

The hippocampus contains the highest density of corticosteroid receptors in the brain, which leads to the suggestion that corticosteroids may have a profound influence on hippocampal signal processing. Previous investigations have demonstrated that corticosteroids modulate hippocampal pyramidal cell membrane electrophysiological characteristics and responses elicited by the activation of different neurotransmitter receptors (Joëls and de Kloet, 1992; Beck *et al.*, 1994; Birnstiel and Beck, 1995; Beck *et al.*, 1996). However, these findings are limited to the cells in subfield CA1. The effects of corticosteroids on neuron cell properties for other hippocampal regions (i.e., dentate gyrus and subiculum) and subfields (i.e., CA2 and CA3) are not known. Information on the actions of corticosteroids in all regions of the hippocampus is essential to determine how corticosteroids modulate signal processing in the hippocampus. Therefore, it was the goal of this dissertation to examine the actions of corticosteroids on cell membrane electrophysiological characteristics and the 5-HT_{1A} receptor signal transduction system in subfield CA3 pyramidal cells. There are two basic hypotheses for this dissertation. First, corticosteroids influence cell membrane

electrophysiological properties in subfield CA3 pyramidal cells. Second, corticosteroids modulate the response elicited by the activation of the 5-HT_{1A} receptor. Furthermore, corticosteroids modulate the 5-HT_{1A} receptor-mediated response by altering different components (i.e., receptor, G protein, potassium channel) of the 5-HT_{1A} receptor signal transduction system.

One major finding of this dissertation is that chronic corticosteroid treatment influenced pyramidal cell membrane electrical properties in subfield CA3. Corticosteroid treatment shifted the ratio of nonburst and burst firing neurons and the action potential duration in subfield CA3. The effects of corticosteroids on the cell firing mode and action potential duration are not likely to be due to changes in cell viability. The cell membrane potential, resistance, and time constant were the same in all treatment groups and similar to those reported in naive animals (Beck *et al.*, 1992). The effects of corticosteroids on the cell firing mode and action potential duration may be secondary to changes in CA3 cell morphology. However, it is unlikely that changes in cell morphology would only affect the cell firing mode and action potential duration.

The alteration in cell firing pattern and action potential duration may have a significant effect on the synaptically encoded signals sent from subfield CA3 to CA1. Shifting the firing pattern of subfield CA3 cells represents a prominent and critical change in the pattern of communication between subfields CA1 and CA3. Further experiments are required to determine the ion channels and mechanism underlying the

corticosteroid-induced changes in cell firing pattern and action potential duration. It is also important to determine if the ratio of burst and nonburst firing cells changes during the diurnal surge of corticosteroids.

Another major finding of this dissertation is that chronic corticosteroid treatment altered the 5-HT concentration-response curve characteristics for the 5-HT_{1A} receptor on subfield CA3 pyramidal cells. Furthermore, corticosteroids altered the 5-HT_{1A} receptor signal transduction system at sites (i.e., G protein) downstream of the receptor. The corticosteroid-induced changes in the 5-HT concentration-response curve characteristics for the 5-HT_{1A} receptor may be due to changes in G protein function. The smaller EC₅₀ and greater E_{max} value observed in cells from ADX treated animals was also accompanied by an increase in the current evoked by the activation of G proteins with GTPγS. Similarly the larger EC₅₀ and smaller E_{max} value observed in cells from HCT treated animals was accompanied by a decrease in the current evoked by the activation of G proteins. However, the ADX- and HCT-induced effects are not directly due to changes in G protein G_{i1 and 2} or G_o α-subunit levels. Based on Western blot analysis, ADX treatment had no effect while HCT treatment increased G_{i1 and 2} and G_o α-subunit levels when compared to SHAM.

Based on these results, there are several possible mechanisms by which corticosteroid treatment may be altering the 5-HT_{1A} receptor system. Corticosteroids may influence the kinetic properties of the potassium channel linked to the 5-HT_{1A}

receptor. Corticosteroid may also modulate G protein function by altering the coupling between G protein and potassium channels, GTP hydrolysis, or the exchange rate of GDP for GTP. These changes in G protein activity or ion channel kinetics may occur through post-translational modification mechanisms (i.e., phosphorylation).

Based on the results from this dissertation and those previously reported by collaborating colleagues (Beck *et al.*, 1994, 1996), it can be concluded that corticosteroids also modulate neural signal processing in the hippocampus by differentially modulating neuron membrane properties in subfields CA1 and CA3. Adrenalectomy and MR activation have opposite effects on action potential duration in subfield CA1 and CA3 cells. There was no difference in the 5-HT concentration-response curve characteristics for the 5-HT_{1A} receptor in cells from SHAM and ADX treated animals in subfield CA1. In contrast, the EC₅₀ value was shifted in cells from ADX compared to SHAM treated animals in subfield CA3. The different effects of corticosteroids on neuron membrane electrical properties in subfields CA1 and CA3 further supports the critical roles that the different hippocampal subfields have on HPA axis activity. One future study that may help to determine the roles of hippocampal subfields CA1 and CA3 on HPA axis activity is examining the effects of stimulating subfields CA1 and CA3 in different treatment groups (i.e. HCT and MR) on corticosterone plasma levels.

Synaptic Activity

The new findings resulting from this dissertation work provide important information on the action of corticosteroids on neural signal processing in the hippocampus. Earlier investigations examined the action of corticosteroids on synaptically driven field potentials in subfield CA1. Stimulating the Schaffer collaterals arising from subfield CA3 pyramidal cells evokes action potentials in CA1 pyramidal cells that summate and produce a corresponding population spike (Andersen *et al.*, 1971). The population spike amplitude in subfield CA1 is decreased in hippocampal sections from adrenalectomized compared to adrenally-intact animals (Rey *et al.*, 1987a,b; Doi *et al.*, 1991; Joëls and Fernhout, 1993). The adrenalectomy-induced effect was reversed when the slice was perfused with basal physiological concentrations of corticosterone. Consistent with the decrease in population spike amplitude, a study using intracellular recording techniques reported that the probability for inducing synaptically driven action potentials was decreased in adrenalectomized compared to adrenally-intact animals (Joëls and de Kloet, 1993). However, the decrease in firing probability was not accompanied by a decrease in the excitatory postsynaptic potential (EPSP) amplitude (Joëls and de Kloet, 1993). Recently, it was demonstrated that the EPSP and inhibitory postsynaptic potential (IPSP) both are decreased in cells from adrenalectomized compared to adrenally-intact animals (Birnstiel and Beck, 1995).

The decrease in population spike amplitude may be explained by the change in pyramidal cell nonbursting to burst firing ratio observed in this dissertation work. A shift in the pyramidal cell's firing pattern in subfield CA3 may decrease the population spike amplitude evoked in subfield CA1. However, this is only a conjecture since the relationship between subfield CA3 nonburst and burst firing cells with the EPSP and population spike amplitude in CA1 cells is not known.

Several important questions have developed from this dissertation. First, what are the mechanisms underlying the shift in the ratio of nonburst to burst firing cells? Since the current(s) underlying burst firing have not been fully characterized, this is a difficult question to address. Second, how is the ratio of nonburst to burst firing cells in subfield CA3 related to the population spike, or EPSP, recorded in subfield CA1? Finally, does corticosteroid treatment also shift the ratio of nonburst to burst firing cells in other regions of the hippocampus? The answers to these questions will provide more insight into the mechanism by which corticosteroids alter neuronal signal processing in the hippocampus.

Chronic Corticosteroid Treatment

Normally, plasma corticosteroid concentrations fluctuate according to circadian rhythm or acute stress (reviewed by Dallman *et al.*, 1987). However long-term increases in plasma corticosteroid concentrations are observed during chronic stress and senescence and are accompanied by changes in hippocampal physiology (Sapolsky

1985; Sapolsky *et al.*, 1985a, 1986; Stein-Behrens *et al.*, 1994). Therefore, investigators have focused on elucidating the mechanisms underlying the changes in hippocampal physiology observed with long-term exposures to high corticosteroid concentrations.

Briefly, chronically high levels of corticosteroids increase the vulnerability of hippocampal CA3 neurons to cell damage (Sapolsky 1985; Sapolsky *et al.*, 1985a; Stein-Behrens *et al.*, 1994). An alteration in Ca^{2+} homeostasis is proposed as one factor that may increase the vulnerability of hippocampal CA3 neurons to cell damage. Increasing the excitability of neurons may elevate intracellular Ca^{2+} concentrations enough to damage a cell (Landfield and Eldridge, 1994). However, HCT treatment did not selectively alter any of the cell membrane properties examined in this dissertation work. Therefore, a two week chronic treatment with high concentrations of corticosterone does not appear to lead to changes in membrane electrical properties that influence neuron excitability in subfield CA3. The effects of HCT treatment on Ca^{2+} homeostasis or isolated Ca^{2+} currents were not examined in this dissertation.

An increase in CA3 pyramidal cell excitability may occur from alterations in the 5-HT_{1A} receptor-mediated response observed in this dissertation work. A decrease in the maximum current elicited by the activation of 5-HT_{1A} receptors was observed in cells from HCT compared to SHAM treated animals. Physiologically, the HCT-induced change decreases the inhibitory response of CA3 pyramidal cells to 5-HT,

which may lead to an increase in the cell's response to excitatory inputs. This question may be addressed by using extracellular recording techniques and examining the effects of HCT treatment on the response of CA3 cells to the stimulation of 5-HT inputs (i.e., raphe).

G protein-linked Receptor Signal Transduction System

Previous investigators have demonstrated that corticosteroids influence the hippocampal 5-HT system in at least two ways. First, corticosteroids alter the response elicited by the activation of either the 5-HT_{1A} (Joëls *et al.*, 1991, Joëls and de Kloet, 1992; Beck *et al.*, 1996) or 5-HT₄ receptors (Birnstiel and Beck, 1995). Second, corticosteroids modulate the number of 5-HT_{1A} receptor binding sites and mRNA expression (reviewed by Chaouloff, 1995). Based on the results from this dissertation work, it was shown that corticosteroids also alter the 5-HT_{1A} signal transduction system at site(s) downstream from the receptor. This observation bears an interesting question. Are other G protein-linked receptor signal transduction systems altered by corticosteroids?

Similar to the results in this dissertation work, the β -adrenergic receptor-mediated response in the hippocampus is also increased in adrenalectomized animals compared to adrenally-intact animals. Adrenalectomy increases NA stimulated cAMP accumulation (Roberts *et al.*, 1984; Harrelson *et al.*, 1987) without altering β -adrenergic receptor

binding (Roberts *et al.*, 1984) or forskolin-stimulated adenylyl cyclase activity (Mobley *et al.*, 1983; Harrelson *et al.*, 1987; Gannon and McEwen, 1990).

No changes in G protein α -subunit levels with ADX were observed in this thesis work. Therefore, the adrenalectomy-induced effect on NA stimulated cAMP accumulation is not occurring by directly altering neurotransmitter receptor binding or G protein levels. Adrenalectomy may be altering the coupling between signal transduction components. In support of this hypothesis, it was observed in this thesis work that the EC_{50} value for the 5-HT_{1A} receptor-mediated response was smaller (i.e. 5-HT was more potent) in cells from ADX compared to SHAM animals. Furthermore, the current elicited by the activation of G proteins with GTP γ S was also greater in cells from ADX compared to SHAM animals. Therefore, adrenalectomy may alter the coupling or activity of signal transduction components downstream of the receptor for either the β -adrenergic or 5-HT_{1A} receptors.

The Hippocampus and HPA Axis Feedback

Finally, the results from this dissertation work provide some insight into how the hippocampus processes its feedback signal to the HPA axis. MR activation is important for maintaining the cell's firing pattern, action potential duration, and sensitivity to 5-HT in subfield CA3 pyramidal cells. Since MR activation modulates pyramidal cell characteristics as well as the 5-HT_{1A} receptor-mediated response, the

activation of MR influences any input signals arriving at subfield CA3 cells.

In contrast, chronic activation of MR and GR together, had no selective effects on cell membrane electrophysiological characteristics but did decrease the inhibitory response of CA3 pyramidal cells to 5-HT. Therefore, the feedback signal from the hippocampus during chronic MR and GR activation may depend on the attenuation of 5-HT mediated responses in the hippocampus.

This dissertation work has contributed new and important information towards elucidating the mechanism by which corticosteroids modulate neural signal processing in the hippocampus. It is now clear that corticosteroids have different effects on cell membrane characteristics and 5-HT_{1A} receptor-mediated responses in subfields CA1 and CA3. Furthermore the selective actions of corticosteroids in the hippocampus may have important ramifications on the development of the HPA axis feedback signal and hippocampus related behaviors.

APPENDIX 1.

PERMISSION TO REPRINT MATERIAL



605 Third Avenue
New York, NY 10158-0012
212.850.6000
FAX 212. 850.6088

John Wiley & Sons, Inc.
Publishers Since 1807

October 8, 1996

Dayne Y. Okuhara
Loyola University Medical Center
Stritch School of Medicine
Department of Pharmacology & Experimental Therapeutics
2160 South First Avenue
Maywood, Illinois 60153

Dear Dayne Okuhara:

Thank you for your request of September 30, 1996. Please be aware that although you assigned rights to this work to us in your contributor agreement, you retained the following print rights:

1. Proprietary rights, other than copyright, such as patent rights.
2. The right to make copies of all or part of the work for your use in classroom teaching.
3. The right to use, after publication, all or part of this material in a book by you or in a collection of your works.
4. The right to make copies of the work for internal distribution within the institution where you work.
5. The right to use figures and tables from the work, and up to 250 words of text, in print media only.
6. The right to make oral presentation of the material in any forum.

We would appreciate you crediting Wiley-Liss, Inc., a subsidiary of Wiley & Sons, Inc. The following components should be included : Title, author(s), journal title, Copyright © (year and owner.).

If you have any questions please call (212) 850-6011.

Sincerely,

A handwritten signature in black ink, appearing to read 'Christopher Sheridan'.

Christopher Sheridan
Senior Permissions Assistant
(212)850-8607

165

REFERENCES

- Abou-Samra AB, Catt KJ, Aguilera G (1986) Biphasic inhibition of adrenocorticotropin release by corticosterone in cultured anterior pituitary cells. *Endocrinology* 119:972-977.
- Addison T (1855) *On the Constitutional and Local Effects of Disease of the Suprarenal Capsule*. London: Sam Highley.
- Ader R, Friedman SB (1968) Plasma corticosterone response to environmental stimulation: effects of duration of stimulation and the 24-hour adrenocortical rhythm. *Neuroendocrinology* 3:378-386.
- Ahima RS, Harlan RE (1990) Charting of type II glucocorticoid receptor-like immunoreactivity in the rat central nervous system. *Neuroscience* 39:579-604.
- Ahima R, Krozowski Z, Harlan R (1991) Type I corticosteroid receptor-like immunoreactivity in the rat CNS: distribution and regulation by corticosteroids. *J Comp Neurol* 313:522-538.
- Akana SF, Cascio CS, Du JZ, Levin N, Dallman MF (1986) Reset of feedback in the adrenocortical system: an apparent shift in sensitivity of adrenocorticotropin to inhibition by corticosterone between morning and evening. *Endocrinology* 119:2325-2332.
- Albert PR, Zhou QY, Van Tol HH, Bunzow JR, Civelli O (1990) Cloning, functional expression, and mRNA tissue distribution of the rat 5-hydroxytryptamine_{1A} receptor gene. *J Biol Chem* 265:5825-5832.
- Andersen P, Bliss TV, Skrede KK (1971a) Unit analysis of hippocampal population spikes. *Exp Brain Res* 13:208-221.
- Andersen P, Bliss TV, Skrede KK (1971b) Lamellar organization of hippocampal pathways. *Exp Brain Res* 13:222-238.

- Andersen P (1975) Organization of hippocampal neurons and their interconnections. In: The hippocampus, vol 1, Structure and development (Issacson RL, Pribram KH eds), pp 155-176. New York: Plenum Press.
- Anderson NS, Fanestil DD (1976) Corticosteroid receptors in rat brain: evidence for an aldosterone receptor. *Endocrinology* 98:676-684.
- Andrade R, Malenka RC, Nicoll RA (1986) A G protein couples serotonin and GABA_B receptors to the same channels in hippocampus. *Science* 234:1261-1265.
- Andrade R, Nicoll RA (1987) Pharmacologically distinct actions of serotonin on single pyramidal neurones of the rat hippocampus recorded in vitro. *J Physiol (Lond)* 394:99-124.
- Andrade R, Chaput Y (1991) 5-Hydroxytryptamine₄-like receptors mediate the slow excitatory response to serotonin in the rat hippocampus. *J Pharmacol Exp Therap* 257:930-937.
- Antakly T, Eisen HJ (1984) Immunocytochemical localization of glucocorticoid receptor in target cells. *Endocrinology* 115:1984-1989.
- Antoni FA (1986) Hypothalamic control of adrenocorticotropin secretion: advances since the discovery of 41-residue corticotropin-releasing factor. *Endocrin Rev* 7:351-378.
- Aoki C, Go C-G, Wu K, Siekevitz P (1992) Light and electron microscopic localization of a subunits of GTP-binding proteins, G_o and G_i, in the cerebral cortex and hippocampus of rat brain. *Brain Res* 596:189-201.
- Aronin N, DiFiglia M (1992) The subcellular localization of the G-protein G_iα in the basal ganglia reveals its potential role in both signal transduction and vesicle trafficking. *J Neurosci* 12:3435-3444.
- Asano T, Semba R, Ogasawara N, Kato K (1987) Highly sensitive immunoassay for the α subunit of the GTP-binding protein G_o and its regional distribution in bovine brain. *J Neurochem* 48:1617-1623.
- Asano T, Nagahama M, Kanefusa K (1990a) Subcellular distribution of GTP-binding proteins, G_o and G_{i2}, in rat cerebral cortex. *J Biochem* 107:694-698.

- Asano T, Shinohara H, Morishita R, Kato K (1990b) Immunochemical and immunohistochemical localization of the G protein G_{i1} in rat central nervous tissues. *J Biochem* 108:988-994.
- Arriza JL, Weinberger C, Cerelli G, Glaser TM, Handelin BL, Housman, DE, Evans RM (1987) Cloning of human mineralocorticoid receptor complementary DNA: structural and functional kinship with the glucocorticoid receptor. *Science* 237:268-275.
- Arriza JL, Simerly RB, Swanson LW, Evans RM (1988) The neuronal mineralocorticoid receptor as a mediator of glucocorticoid response. *Neuron* 1:887-900.
- Azmitia EC, Segal M (1978) An autoradiographic analysis of the differential ascending projections of the dorsal and median raphe nuclei in the rat. *J Comp Neurol* 179:641-667.
- Arriza JL, Simerly RB, Swanson LW, Evans RM (1988) The neuronal mineralocorticoid receptor as a mediator of glucocorticoid response. *Neuron* 1:887-900.
- Azmitia EC, McNaughton N, Tsaltas L, Fillenz M, Gray JA (1984) Interactions between hippocampal serotonin and the pituitary-adrenal axis in the septal driving of hippocampal theta-rhythm. *Neuroendocrinology* 39:471-475.
- Azouz R, Jensen MS, Yaari Y (1996) Ionic basis of spike after-depolarization and burst generation in adult rat hippocampal CA1 pyramidal cells. *J Physiol (London)* 492:211-223.
- Barden N, Reul JM, Holsboer F (1995) Do antidepressants stabilize mood through actions on the hypothalamic-pituitary-adrenocortical system? *Trends Neurosci* 18:6-11.
- Barnes PJ (1996) Molecular mechanisms of steroid action in asthma. *J Allergy Clin Immunol* 97:159-168.
- Beale EG, Hartley JL, Granner DK (1982) N_6, O_2^1 -dibutyryl cycle AMP and glucose regulate the amount of messenger RNA coding for hepatic phosphoenolpyruvate carboxykinase (GTP). *J Biol Chem* 257:2022-2028.
- Beato M (1989) Gene regulation by steroid hormones. *Cell* 56:335-344.

Beaumont K, Fanestil DD (1983) Characterization of rat brain aldosterone receptors reveals high affinity for corticosterone. *Endocrinology* 113:2043-2051.

Beck SG (1989) 5-Carboxyamidotryptamine mimics only the 5-HT elicited hyperpolarization of hippocampal pyramidal cells via 5-HT_{1A} receptor. *Neurosci Lett* 99:101-106.

Beck SG, Choi KC (1991) 5-Hydroxytryptamine hyperpolarizes CA3 hippocampal pyramidal cells through an increase in potassium conductance. *Neurosci Lett* 133:93-96.

Beck SG, Choi KC, List TJ (1992) Comparison of 5-hydroxytryptamine_{1A}-mediated hyperpolarization in CA1 and CA3 hippocampal pyramidal cells. *J Pharmacol Exp Ther* 263:350-359.

Beck SG, List TJ, Choi KC (1994) Long- and short-term administration of corticosterone alters CA1 hippocampal neuronal properties. *Neuroendocrinology* 60:261-272.

Beck SG, Birnstiel S, Pouliot WA, Choi KC (1995) Baclofen concentration-response curves differ between hippocampal subfields. *Neuroreport* 6:310-312.

Beck SG, Choi KC, List TJ, Okuhara DY, Birnstiel S (1996) Corticosterone alters 5-HT_{1A} receptor-mediated hyperpolarization in area CA1 hippocampal pyramidal neurons. *Neuropsychopharmacology* 14:27-33.

Bernard C, Wheal HV (1994) Model of local connectivity patterns in CA3 and CA1 areas of the hippocampus. *Hippocampus* 4:497-529.

Bernard PA, Joh TH (1984) Characterization and immunocytochemical demonstration of glucocorticoid receptor using antisera specific to transformed receptor. *Arch Biochem Biophys* 229:466-476.

Benardo LS, Masukawa LM, Prince DA (1982) Electrophysiology of isolated hippocampal pyramidal dendrites. *J Neurosci* 2:1614-1622.

- Bertherat J, Dournaud P, Berod A, Normand E, Bloch B, Rostene W, Kordon C, Epelbau, J (1992) Growth hormone-releasing hormone-synthesizing neurons are a subpopulation of somatostatin receptor-labelled cells in the rat arcuate nucleus: a combined *in situ* hybridization and receptor light-microscopic radioautographic study. *Neuroendocrinology* 56:25-31.
- Beyer HS, Matta SG, Sharp BM (1988) Regulation of the messenger ribonucleic acid for corticotropin-releasing factor in the paraventricular nucleus and other brain sites of the rat. *Endocrinology* 123:2117-2123.
- Biegon A, Fischette CT, Rainbow TC, McEwen BS (1982) Serotonergic receptor modulation by estrogen in discrete brain nuclei. *Neuroendocrinology* 35:287-291.
- Bilkey DK, Schwartzkroin PA (1990) Variation in electrophysiology and morphology of hippocampal CA3 pyramidal cells. *Brain Res* 514:77-83.
- Birnbaumer L (1990) G proteins in signal transduction. *Annu Rev Pharmacol Toxicol* 30:675-705.
- Birnbaumer L (1992) Receptor-to-effector signaling through G proteins: roles for beta gamma dimers as well as alpha subunits. *Cell* 71:1069-1072.
- Birnbaumer L, Birnbaumer M (1995) Signal transduction by G proteins: 1994 edition. *J Receptor Signal Transduction Res* 15:213-252.
- Birnstiel S, Beck SG (1995) Modulation of the 5-hydroxytryptamine₄ receptor-mediated response by short-term and long-term administration of corticosterone in rat CA1 hippocampal pyramidal neurons. *J Pharmacol Exp Therap* 273:1132-1138.
- Birnstiel S, List TJ, Beck SG (1995) Chronic corticosterone treatment maintains synaptic activity of CA1 hippocampal pyramidal cells: acute high corticosterone administration increases action potential number. *Synapse* 20:117-124.
- Block KP, Richmond WB, Mehard WB, Buse MG (1987) Glucocorticoid-mediated activation of muscle branched-chain alpha-keto acid dehydrogenase in vivo. *Am J Physiol* 252:E396-E407.
- Block KP, Buse MG (1990) Glucocorticoid regulation of muscle branched-chain amino acid metabolism. *Med Sci Sports Exercise* 22:316-324.

Boess FG, Martin IL (1994) Molecular biology of 5-HT receptors. *Neuropharmacology* 33:275-317.

Bohus B, Greidanus TVW, De Wied D (1975) Behavioral and endocrine responses of rats with hereditary hypothalamic diabetes insipidus (Brattleboro strain). *Physiol Behav* 14:609-615.

Braak H, Braak E (1992) Anatomy of the human hypothalamus (chiasmatic and tuberal region). *Prog Brain Res* 93:3-14.

Bradbury MJ, Akana SF, Cascio CS, Levin N, Jacobson L, Dallman MF (1991) Regulation of basal ACTH secretion by corticosterone is mediated by both type I (MR) and type II (GR) receptors in rat brain. *J Steroid Biochem Mol Biol* 40:133-142.

Bradbury MJ, Akana SF, Dallman MF (1994) Roles of type I and II corticosteroid receptors in regulation of basal activity in the hypothalamo-pituitary-adrenal axis during the diurnal trough and the peak: evidence for a nonadditive effect of combined receptor occupation. *Endocrinology* 134:1286-1296.

Brady LS, Whitfield HJ, Jr., Fox RJ, Gold PW, Herkenham M (1991) Long-term antidepressant administration alters corticotropin-releasing hormone, tyrosine hydroxylase, and mineralocorticoid receptor gene expression in rat brain. Therapeutic implications. *J Clin Invest* 87:831-837.

Brann MR, Collins RM, Spiegel A (1987) Localization of mRNAs encoding the α -subunits of signal-transducing G proteins within rat brain and among peripheral tissues. *FEBS Lett* 222:191-198.

Brattin WJ, Portanova R (1977) Corticosterone induction of pituitary hyporesponsiveness to CRF: divergent effects of puromycin and cycloheximide. *Mol Cell Endocrinol* 7:221-231.

Bray P, Carter A, Simons C, Guo, V, Puckett C, Kamholtz J, Spiegel A, Nirenberg N (1986) Human cDNA clones for four species of G α signal transduction protein. *Proc Natl Acad Sci USA* 83:8893-8897.

Brenner T, Mizrachi R, Bodoff M, Weidenfeld J (1986) Evidence that central nicotinic-acetylcholine receptors are involved in the modulation of basal and stress-induced adrenocortical responses. *Exp Neurol* 94:735-743.

- Brown TH, Fricke RA, Perkel DH (1981) Passive electrical constants in three classes of hippocampal neurons. *J Neurophysiol* 46:812-827.
- Buckingham JC, Hodges JR (1977) The use of corticotrophin production by adeno-hypophysial tissue in vitro for the detection and estimation of potential corticotrophin releasing factors. *J Endocrinology* 72:187-193.
- Budziszewska B, Lason W (1994) Pharmacological modulation of glucocorticoid and mineralocorticoid receptors in the rat central nervous system. *Pol J Pharmacol* 46:97-102.
- Budziszewska B, Siwanowicz J, Przegalinski E (1995) Role of the serotonergic system in the regulation of glucocorticoid and mineralocorticoid receptors in the rat hippocampus. *Pol of Pharmacol* 47:299-304.
- Burgess LH, Handa RJ (1992) Chronic estrogen-induced alterations in adrenocorticotropin and corticosterone secretion, and glucocorticoid receptor-mediated functions in female rats. *Endocrinology* 131:1261-1269.
- Burnstein KL, Bellingham DL, Jewell CM, Powell-Oliver FE, Cidlowski, JA. (1991) Autoregulation of glucocorticoid receptor gene expression. *Steroids* 56:52-58.
- Calogero AE, Bernardini R, Margioris AN, Bagdy G, Gallucci WT, Munson, PJ, Tamarkin L, Tomai TP, Brady L, Gold PW (1989) Effects of serotonergic agonists and antagonists on corticotropin-releasing hormone secretion by explanted rat hypothalami. *Peptides* 10:189-200.
- Cameron HA, Gould E (1996) Distinct populations of cells in the adult dentate gyrus undergo mitosis or apoptosis in response to adrenalectomy. *J Comp Neurol* 369:56-63.
- Canny BJ, Funder JW, Clarke IJ (1989) Glucocorticoids regulate ovine hypophysial portal levels of corticotropin-releasing factor and arginine vasopressin in a stress-specific manner. *Endocrinology* 125:2532-2539.
- Carlstedt-Duke J, Gustaffson JA, Wrangé O (1977) Formation and characteristics of hepatic dexamethasone-receptor complexes of different molecular weight. *Biochim Biophys Acta* 497:507-524.

Carlstedt-Duke J, Okret S, Wrangé O, Gustafsson JA (1982) Immunochemical analysis of the glucocorticoid receptor: identification of a third domain separate from the steroid-binding and DNA-binding domains. *Proc Natl Acad Sci USA* 79:4260-4264.

Carlstedt-Duke J, Stromstedt PE, Wrangé O, Bergman T, Gustafsson JA (1987) Domain structure of the glucocorticoid receptor protein. *Proc Natl Acad Sci USA* 84:4437-4440.

Casolini P, Piazza PV, Kabbaj M, Leprat F, Angelucci L, Simon H, LeMoal M, Maccari S (1993) The mesolimbic dopaminergic system exerts an inhibitory influence on brain corticosteroid receptor affinities. *Neuroscience* 55:429-434.

Casolini P, Kabbaj M, Piazza PV, Angelucci L, Simon H, Le Moal M, Maccari S (1994) The D1 dopamine agonist SKF 38393, but not the D2 agonist LY 171555, decreases the affinity of type II corticosteroid receptors in rat hippocampus and ventral striatum. *Neuroscience* 60:939-943.

Catelli MG, Binart N, Jung-Testas I, Renoir JM, Baulieu EE, Feramisco, JR, Welch WJ (1985) The common 90-kd protein component of non-transformed '8S' steroid receptors is a heat-shock protein. *EMBO J* 4:3131-3135.

Ceccatelli S, Cintra A, Hokfelt T, Fuxe K, Wikstrom AC, Gustafsson JA. (1989) Coexistence of glucocorticoid receptor-like immunoreactivity with neuropeptides in the hypothalamic paraventricular nucleus. *Exp Brain Res* 78:33-42.

Chalepakis G, Schauer M, Cao XA, Beato M (1990) Efficient binding of glucocorticoid receptor to its responsive element requires a dimer and DNA flanking sequences. *DNA Cell Biol* 9:355-368.

Chalmers DT, Kwak SP, Mansour A, Akil H, Watson SJ (1993) Corticosteroids regulate brain hippocampal 5-HT_{1A} receptor mRNA expression. *J Neurosci* 13:914-923.

Chanda PK, Minchin MC, Davis AR, Greenberg L, Reilly Y, McGregor WH, Bhat R, Lubeck MD, Mizutani S, Hung PP (1993) Identification of residues important for ligand binding to the human 5-hydroxytryptamine_{1A} serotonin receptor. *Mol Pharmacol* 43:516-520.

Chao HM, Choo PH, McEwen BS (1989) Glucocorticoid and mineralocorticoid receptor mRNA expression in rat brain. *Neuroendocrinology* 50:365-371.

- Chaouloff F (1995) Regulation of 5-HT receptors by corticosteroids: where do we stand? *Fundam Clin Pharmacol* 9:219-233.
- Checkley S (1992) Neuroendocrine mechanisms and the precipitation of depression by life events. *Brit J Psychiatry - Supplement* 7-17.
- Chiu SY, Kriegler S (1994) Neurotransmitter-mediated signaling between axons and glial cells. *Glia* 11:191-200.
- Chu LL, Edelman IS (1972) Cordycepin and alpha-amanitin: inhibitors of transcription as probes of aldosterone action. *J Membr Biol* 10:291-310.
- Cintra A, Bortolotti F (1992) Presence of strong glucocorticoid receptor immunoreactivity within hypothalamic and hypophyseal cells containing pro-opiomelanocortin peptides. *Brain Res* 577:127-133.
- Clapham DE (1994) Direct G protein activation of ion channels. *Annu Rev Neurosci* 17:441-464.
- Cohen SI (1980) Cushing's syndrome: a psychiatric study of 29 patients. *Br J Psychiatry* 136:120-124.
- Coirini H, Marusic ET, De Nicola AF, Rainbow TC, McEwen BS (1983) Identification of mineralocorticoid binding sites in rat brain by competition studies and density gradient centrifugation. *Neuroendocrinology* 37:354-360.
- Coirini H, Magarinos AM, De Nicola AF, Rainbow TC, McEwen BS (1985) Further studies of brain aldosterone binding sites employing new mineralocorticoid and glucocorticoid receptor markers in vitro. *Brain Res* 361:212-216.
- Coleman PD, Flood DG (1987) Neuron numbers and dendritic extent in normal aging and Alzheimer's disease. *Neurobiol Aging* 8:521-545.
- Conn PJ, Sanders-Busch E, Hoffman BJ, Hartig P (1986) A unique serotonin receptor in choroid plexus is linked to phosphatidylinositol turnover. *Proc Natl Acad Sci USA* 83:4086-4088.
- Colino A, Halliwell JV (1987) Differential modulation of three separate K-conductances in hippocampal CA1 neurons by serotonin. *Nature (London)* 328:73-77.

Cooper DMF, Boyajian CL, Goldsmith PK, Unson CG, Spiegel A (1990) Differential expression of low molecular weight form of G_s - α in neostriatum and cerebellum: correlation with expression of calmodulin-independent adenylyl cyclase. *Brain Res* 523:143-146.

Crouch MF, Heydon K, Garnaut SM, Milburn PJ, Hendry IA (1994) Retrograde transport of the alpha-subunit of the GTP-binding protein G_z in mouse sciatic nerve: a potential pathway for signal transduction in the neurons. *Eur J Neurosci* 6:626-631.

Cunningham ET, Jr., Sawchenko PE (1988) Anatomical specificity of noradrenergic inputs to the paraventricular and supraoptic nuclei of the rat hypothalamus. *J Comp Neurol* 274:60-76.

Cunningham ET, Jr., Bohn MC, Sawchenko PE (1990) Organization of adrenergic inputs to the paraventricular and supraoptic nuclei of the hypothalamus in the rat. *J Comp Neurol* 292:651-667.

Cushing H (1932) The basophil adenomas of the pituitary body and their clinical manifestations (pituitary basophilism). *Bull John Hopkins Hosp* 50:137-195.

Dahlman-Wright K, Wright A, Carlstedt-Duke J, Gustafsson JA (1992) DNA-binding by the glucocorticoid receptor: a structural and functional analysis. *J Steroid Biochem Mol Biol* 41:249-272.

Dallman MF, Makara GB, Roberts JL, Levin N, Blum M (1985) Corticotrope response to removal of releasing factors and corticosteroids in vivo. *Endocrinology* 117:2190-2197.

Dallman MF, Akana SF, Cascio CS, Darlington DN, Jacobson L, Levin N (1987) Regulation of ACTH secretion: variations on a theme of B. *Recent Prog Horm Res* 43:113-173.

Dallman MF, Akana SF, Levin N, Walker CD, Bradbury MJ, Suemaru S (1994) Corticosteroids and the control of function in the hypothalamo-pituitary-adrenal (HPA) axis. *Ann N Y Acad Sci* 746:22-31.

Dalman FC, Sanchez ER, Lin AL, Perini F, Pratt WB (1988) Localization of phosphorylation sites with respect to the functional domains of the mouse L cell glucocorticoid receptor. *J Biol Chem* 263:12259-12267.

Daniels WM, Jaffer A, Russell VA, Taljaard JJ (1993) Alpha 2- and beta-adrenergic stimulation of corticosterone secretion in rats. *Neurochem Res* 18:159-164.

Daniels WM, Jaffer A, Russell VA, Taljaard JJ (1994) Decreased hippocampal noradrenaline does not affect corticosterone release following electrical stimulation of CA1 pyramidal cells. *Neurochem Res* 19:1539-1543.

Danielsen M, Northrop JP, Ringold GM (1986) The mouse glucocorticoid receptor: mapping of functional domains by cloning, sequencing and expression of wild-type and mutant receptor proteins. *EMBO J* 5:2513-2522.

Danielsen M, Northrop JP, Jonklaas J, Ringold GM (1987) Domains of the glucocorticoid receptor involved in specific and nonspecific deoxyribonucleic acid binding, hormone activation, and transcriptional enhancement. *Mol Endocrinol* 1:816-822.

Davidson JM, Feldman S (1967) Effects of extrahypothalamic dexamethasone implants on the pituitary-adrenal system. *Acta Endocrinol (Copenh)* 55:240-246.

Davis LG, Arentzen R, Reid JM, Manning RW, Wolfson B, Lawrence KL, Baldino F, Jr. (1986) Glucocorticoid sensitivity of vasopressin mRNA levels in the paraventricular nucleus of the rat. *Proc Natl Acad Sci USA* 83:1145-1149.

Dayanithi G, Antoni FA (1989) Rapid as well as delayed inhibitory effects of glucocorticoid hormones on pituitary adrenocorticotrophic hormone release are mediated by type II glucocorticoid receptors and require newly synthesized messenger ribonucleic acid as well as protein. *Endocrinology* 125:308-313.

de Kloet R, Wallach G, McEwen BS (1975) Differences in corticosterone and dexamethasone binding to rat brain and pituitary. *Endocrinology* 96:598-609.

de Kloet ER, De Wied D (1980) The brain as target tissue for hormones of pituitary origin: behavioral and biochemical studies. In: *Frontiers in Neuroendocrinology* (Martini L, Ganong WF eds), pp 157-170. New York: Raven Press.

de Kloet ER, Reul JM, de Ronde FS, Bloemers M, Ratka A (1986a) Function and plasticity of brain corticosteroid receptor systems: action of neuropeptides. *J Steroid Biochem* 25:723-731.

de Kloet ER, Sybesma H, Reul HM (1986b) Selective control by corticosterone of serotonin₁ receptor capacity in raphe-hippocampal system. *Neuroendocrinology* 42:513-521.

de Kloet ER, Reul JM (1987) Feedback action and tonic influence of corticosteroids on brain function: a concept arising from the heterogeneity of brain receptor systems. *Psychoneuroendocrinology* 12:83-105.

de Kloet ER (1991) Brain corticosteroid receptor balance and homeostatic control. *Frontiers Neuroendocrinol* (Ganong WF, Martini L eds), pp 95-165. Raven Press.

de Kloet ER, Sutanto W, Rots N, van Haarst A, van den Berg D, Oitzl M., van Eekelen A, Voorhuis D (1991) Plasticity and function of brain corticosteroid receptors during aging. *Acta Endocrinol* (Copenh) 125 Suppl 1:65-72.

de Kloet ER, Oitzl MS, Joëls M (1993) Functional implications of brain corticosteroid receptor diversity. *Cell Mol Neurobiol* 13:433-455.

de Montigny C, Aghajanian GK (1978) Tricyclic antidepressants: long-term treatment increases responsivity of rat forebrain neurons to serotonin. *Science* 202:1303-1306.

De Nicola AF, Tornello S, Weisenberg L, Fridman O, Birmingham MK (1981) Uptake and binding of [³H]aldosterone by the anterior pituitary and brain regions in adrenalectomized rats. *Horm Metab Res* 13:103-106.

de Wied D (1971) Long term effect of vasopressin on the maintenance of a conditioned avoidance response in rats. *Nature* (London) 232:58-60.

de Weid D, Bohus B, van Wimersma Greidanus TB (1975) Memory deficit in rats with hereditary diabetes insipidus. *Brain Res* 85:152-156.

de Wied D, Jolles J (1982) Neuropeptides derived from pro-opiocortin: behavioral, physiological, and neurochemical effects. *Physiol Rev* 62:976-1059.

Derijk R, Sternberg EM (1994) Corticosteroid action and neuroendocrine-immune interactions. *Ann N Y Acad Sci* 746:33-4.

Doi N, Miyahara S, Hori N (1991) Glucocorticoids promote localized activity of rat hippocampal CA1 pyramidal neurons in brain slices. *Neurosci Lett* 123:99-101.

Drinnan SL, Hope BT, Snutch TP, Vincent SR (1991) G_{olf} in the basal ganglia. *Mol Cell Neurosci* 2:66-70.

Dunn J, Scheving L, Millet P (1972) Circadian variation in stress-evoked increases in plasma corticosterone. *Am J Physiol* 223:402-406.

Dunn JD, Orr SE (1984) Differential plasma corticosterone responses to hippocampal stimulation. *Exp Brain Res* 54:1-6.

Eaton DC, Becchetti A, Ma H, Ling BN (1995) Renal sodium channels: regulation and single channel properties. *Kidney Int* 48:941-949.

el Mestikawy S, Fargin A, Raymond JR, Gozlan H, Hnatowich M (1991) The 5-HT_{1A} receptor: an overview of recent advances. *Neurochem Res* 16:1-10.

Eldridge JC, Brodish A, Kute TE, Landfield PW (1989a) Apparent age-related resistance of type II hippocampal corticosteroid receptors to down-regulation during chronic escape training. *J Neurosci* 9:3237-3242.

Eldridge JC, Fleenor DG, Kerr DS, Landfield PW (1989b) Impaired up-regulation of type II corticosteroid receptors in hippocampus of aged rats. *Brain Res* 478:248-256.

Elliott EM, Sapolsky RM (1993) Corticosterone impairs hippocampal neuronal calcium regulation--possible mediating mechanisms. *Brain Res* 602:84-90.

Ercolani L, Stow JL, Boyle JF, Holtzman EJ, Lin H, Grove JR, Ausiello DA (1990) Membrane localization of the pertussis toxin-sensitive G-14 protein subunits α_{i-2} and α_{i3} and expression of a metallothionein- α_{i-2} fusion gene in LLC-PK₁ cells. *Proc Natl Acad Sci USA* 87:4635-4639.

Ernst SJ, Palacios JR, Siegel SG (1986) Immunocytochemical localization of Na⁺-K⁺ ATPase catalytic polypeptide in mouse choroid plexus. *J Histochem Cytochem* 34:189-195.

Evans RM (1988) The steroid and thyroid hormone receptor superfamily. *Science* 240:889-895.

Ewart HS, Klip A (1995) Hormonal regulation of the Na(+)-K(+)-ATPase: mechanisms underlying rapid and sustained changes in pump activity. *Am J Physiol* 269:C295-C311.

Falaschi P, Martocchia A, Proietti A, Pastore R, D'Urso R (1994) Immune system and the hypothalamus-pituitary-adrenal axis. Common words for a single language. *Ann N Y Acad Sci* 741:223-233.

Fargin A, Raymond JR, Lohse MJ, Kobilka BK, Caron MG, Lefkowitz RJ (1988) The genomic clone G-21 which resembles a beta-adrenergic receptor sequence encodes the 5-HT_{1A} receptor. *Nature (London)* 335:358-360.

Feldman S, Conforti N (1976) Feedback effects of dexamethasone on adrenocortical responses in rats with fornix section. *Horm Res* 7:56-60.

Feldman S, Conforti N (1980) Participation of the dorsal hippocampus in the glucocorticoid feedback effect on adrenocortical activity. *Neuroendocrinology* 30:52-55.

Feldman S, Melamed E, Conforti N, Weidenfeld J (1984) Inhibition in corticotrophin and corticosterone secretion following photic stimulation in rats with 6-hydroxydopamine injection into the medial forebrain bundle. *J Neurosci Res* 12:87-92.

Feldman S (1985) Neural pathways mediating adrenocortical responses. *Fed Proc* 44:169-175.

Feldman S, Conforti N, Saphier D (1990) Adrenal responses and neurotransmitters in posterior hypothalamic deafferentation. *Brain Res Bull* 25:75-78.

Feldman S, Weidenfeld J (1991) Depletion of hypothalamic norepinephrine and serotonin enhances the dexamethasone negative feedback effect on adrenocortical secretion. *Psychoneuroendocrinology* 16:397-405.

Feldman S, Weidenfeld J, Conforti N, Saphier D (1991) Differential recovery of adrenocortical responses to neural stimuli following administration of 5,7-dihydroxytryptamine into the hypothalamus. *Exp Brain Res* 85:144-148.

Feldman S, Saphier D, Weidenfeld J (1992) Corticosterone implants in the paraventricular nucleus inhibit ACTH and corticosterone responses and the release of corticotropin-releasing factor following neural stimuli. *Brain Res* 578:251-255.

Feldman S, Conforti N, Weidenfeld J (1995) Limbic pathways and hypothalamic neurotransmitters mediating adrenocortical responses to neural stimuli. *Neurosci Biobehav Rev* 19:235-240.

- Feldman S, Weidenfeld J (1995) Neural mechanisms involved in the corticosteroid feedback effects on the hypothalamo-pituitary-adrenocortical axis. *Prog Neurobiol* 45:129-141.
- Fendler K, Karmos G, Telegdy G (1961) The effect of hippocampal lesion on pituitary-adrenal function. *Acta Physiol Acad Sci Hung* 20:293-297.
- Fink G, Robinson IC, Tannahill LA (1988) Effects of adrenalectomy and glucocorticoids on the peptides CRF- 41, AVP and oxytocin in rat hypophysial portal blood. *J Physiol (Lond)* 401:329-345.
- Fischette CT, Komisaruk BR, Edinger HM, Feder HH, Siegel A (1980) Differential fornix ablations and the circadian rhythmicity of adrenal corticosteroid secretion. *Brain Res* 195:373-387.
- Florio VA, Sternweis PC (1985) Reconstitution of resolved muscarinic cholinergic receptors with purified GTP-binding proteins. *J Biol Chem* 260:3477-3483.
- Florini JR (1987) Hormonal control of muscle growth. *Muscle Nerve* 10:577-598.
- Florio VA, Sternweis PC (1989) Mechanisms of muscarinic receptor action on G_o in reconstituted phospholipid vesicles. *J Biol Chem* 264:3909-3915.
- Freedman LP, Luisi BF, Korszun ZR, Basavappa R, Sigler PB, Yamamoto, KR. (1988) The function and structure of the metal coordination sites within the glucocorticoid receptor DNA binding domain. *Nature (London)* 334:543-546.
- French CR, Sah P, Buckett KJ, Gage PW (1990) A voltage-dependent persistent sodium current in mammalian hippocampal neurons. *J Gen Physiol* 95:1139-1157.
- Freo U, Holloway HW, Kalogeras K, Rapoport SI, Soncrant TT (1992) Adrenalectomy or metyrapone-pretreatment abolishes cerebral metabolic responses to the serotonin agonist 1-(2,5-dimethoxy-4-iodophenyl)-2-aminopropane (DOI) in the hippocampus. *Brain Res* 586:256-264.
- Fujiwara Y, Nelson DL, Kashihara K, Varga E, Roeske WR, Yamamura HI (1990) The cloning and sequence analysis of the rat serotonin-1A receptor gene. *Life Sci* 47:PL127-32.

- Fuller RW (1981) Serotonergic stimulation of pituitary-adrenocortical function in rats. *Neuroendocrinology* 32:118-127.
- Fuller RW, Snoddy HD (1990) Serotonin receptor subtypes involved in the elevation of serum corticosterone concentration in rats by direct- and indirect-acting serotonin agonists. *Neuroendocrinology* 52:206-211.
- Funder JW (1993) Aldosterone action. *Annu Rev Physiol* 55:115-130.
- Fung BK (1983) Characterization of transducin from bovine retinal rod outer segments. I. Separation and reconstitution of the subunits. *J Biol Chem* 258:10495-10502.
- Fuxe K, Wikstrom AC, Okret S, Agnati LF, Harfstrand A, Yu ZY, Zoli M, Vale W, Gustafsson JA (1985) Mapping of glucocorticoid receptor immunoreactive neurons in the rat tel- and diencephalon using a monoclonal antibody against rat liver glucocorticoid receptor. *Endocrinology* 117:1803-1812.
- Gagne D, Pons M, Philibert D (1985) RU 38486: a potent antiglucocorticoid in vitro and in vivo. *J Steroid Biochem* 23:247-251.
- Gannon MN, Akompong T, Billingsley ML, McEwen BS (1994) Adrenalectomy-induced alterations of calmodulin-dependent hippocampal adenylate cyclase activity: role of guanine nucleotide-binding proteins. *Endocrinology* 134:853-857.
- Ganong WF (1963) The central nervous system and the synthesis and release of adrenocorticotrophic hormone. In: *Advances in Neuroendocrinology* (Nalbandov AV ed), pp 92 Urbana: University of Illinois Press.
- Garty H (1986) Mechanisms of aldosterone action in tight epithelia. *J Membr Biol* 90:193-205.
- Gasc JM, Delahaye F, Baulieu EE (1989) Compared intracellular localization of the glucocorticosteroid and progesterone receptors: an immunocytochemical study. *Exp Cell Res* 181:492-504.
- Geering K, Girardet M, Bron C, Kraehenbuhl JP, Rossier BC (1982) Hormonal regulation of (Na⁺,K⁺)-ATPase biosynthesis in the toad bladder. Effect of aldosterone and 3,5,3'-triiodo-L-thyronine. *J Biol Chem* 257:10338-10343.

Gehring U, Segnitz B (1988) Modulation of DNA binding of glucocorticoid receptors. *Mol Cell Endocrinol* 56:245-254.

Gehring U (1993) The structure of glucocorticoid receptors. *J Steroid Biochem Mol Biol* 45:183-190.

Gerfen CR, Herkenham M, Thibault J (1987) The neostriatal mosaic: II. patch- and matrix-directed mesostriatal dopaminergic and non-dopaminergic systems. *J Neurosci* 7:3915-3934.

Gerlach JL, McEwen BS (1972) Rat brain binds adrenal steroid hormone: radioautography of hippocampus with corticosterone. *Science* 175:1133-1136.

Gibbs FP (1970) Circadian variation of ether-induced corticosterone secretion in the rat. *Am J Physiol* 219:288-292.

Giguere V, Cotoe J, Labrie F (1982) Specific inhibition by glucocorticoids of the alpha 2-adrenergic stimulation of adrenocorticotropin release in rat anterior pituitary cells. *Endocrinology* 110:1225-1230.

Giguere V, Hollenberg SM, Rosenfeld MG, Evans RM (1986) Functional domains of the human glucocorticoid receptor. *Cell* 46:645-652.

Gilbert F, Brazell C, Tricklebank MD, Stahl SM (1988) Activation of the 5-HT_{1A} receptor subtype increases rat plasma ACTH concentration. *Eur J Pharmacol* 147:431-439.

Gillies G, Lowry PJ (1978) Perfused rat isolated anterior pituitary cell column as bioassay for factor(s) controlling release of adrenocorticotropin: validation of a technique. *Endocrinology* 103:521-527.

Gilman AG (1984) G proteins and dual control of adenylate cyclase. *Cell* 36:577-579.

Gilman AG (1987) G protein: transducers of receptors-generated signals. *Annu Rev Biochem* 56:615-649.

Godowski PJ, Rusconi S, Miesfeld R, Yamamoto KR (1987) Glucocorticoid receptor mutants that are constitutive activators of transcriptional enhancement. *Nature (London)* 325:365-368.

Goldsmith P, Geirschik P, Milligan G, Unson CG, Vinitsky R, Malech HL, Spiegel AM (1987) Antibodies directed against synthetic peptides distinguish between GTP-binding proteins in neutrophil and brain. *J Biol Chem* 262:14683-14688.

Gould E, Woolley CS, McEwen BS (1990) Short-term glucocorticoid manipulations affect neuronal morphology and survival in the adult dentate gyrus. *Neuroscience* 37:367-375.

Gould E, Woolley CS, McEwen BS (1991) The hippocampal formation: morphological changes induced by thyroid, gonadal and adrenal hormones. *Psychoneuroendocrinology* 16:67-84.

Govindan MV (1980) Immunofluorescence microscopy of the intracellular translocation of glucocorticoid-receptor complexes in rat hepatoma (HTC) cells. *Exp Cell Res* 127:293-297.

Govindan MV, Manz B (1980) Three-step purification of glucocorticoid receptors from rat liver. *Eur J Biochem* 108:47-53.

Govindan MV, Gronemeyer H (1984) Characterization of the rat liver glucocorticoid receptor purified by DNA-cellulose and ligand affinity chromatography. *J Biol Chem* 259:12915-12924.

Grandics P, Miller A, Schmidt TJ, Mittman D, Litwack G (1984) Purification of the unactivated glucocorticoid receptor and its subsequent in vitro activation. *J Biol Chem* 259:3173-3180.

Graybiel AM (1990) Neurotransmitters and neuromodulators in the basal ganglia. *Trends Neurosci* 13:244-254.

Greven H, de Weid D (1973) The influence of peptides derived from corticotrophin (ACTH) on performance: structure-activity studies. *Prog Brain Res* 39:429-442.

Grosser BI, Stevens W, Bruenger FW, Reed DJ (1971) Corticosterone binding by rat brain cytosol. *J Neurochem* 18:1725-1732.

Grosser BI, Stevens W, Reed DJ (1973) Properties of corticosterone-binding macromolecules from rat brain cytosol. *Brain Res* 57:387-395.

- Guan XM, Peroutka SJ, Kobilka BK (1992) Identification of a single amino acid residue responsible for the binding of a class of beta-adrenergic receptor antagonists to 5-hydroxytryptamine_{1A} receptors. *Mol Pharmacol* 41:695-698.
- Guillemin R, Dear WE, Liebelt RA (1959) Nychthemeral variations in plasma free corticosteroid levels of the rat. *Proc Soc Exp Biol Med* 101:394-395.
- Guillaume V, Conte-Devolx B, Szafarczyk A, Malaval F, Pares-Herbute N, Grino M, Alonso G, Assenmacher I, Oliver C (1987) The corticotropin-releasing factor release in rat hypophysial portal blood is mediated by brain catecholamines. *Neuroendocrinology* 46:143-146.
- Haigh RM, Jones CT, Milligan G (1990) Glucocorticoids regulate the amount of G proteins in rat aorta. *J Mol Endocrinol* 5:185-188.
- Halasz B, Vernikos-Danellis J, Gorski RA (1967) Pituitary ACTH content in rats after partial or total interruption of neural afferents to the medial basal hypothalamus. *Endocrinology* 81:921-924.
- Hard T, Kellenbach E, Boelens R, Maler BA, Dahlman K, Freedman LP, Yamamoto KR, Gustafsson JA, Kaptein R (1990) Solution structure of the glucocorticoid receptor DNA-binding domain. *Science* 249:157-160.
- Harris GW (1948) Neural control of the pituitary gland. *Physiol Rev* 28:139-179.
- Hartig PR (1989) Molecular biology of 5-HT receptors. *Trends Pharmacol Sci* 10:64-69.
- Hedge GA, Smelik PG (1968) Corticotropin release: inhibition by intrahypothalamic implantation of atropine. *Science* 159:891-892.
- Hendry IA, Crouch MF (1991) Retrograde axonal transport of the GTP-binding protein Gi α : a potential neurotrophic intra-axonal messenger. *Neurosci Lett* 133:29-32.
- Henkin RI (1970) The effects of corticosteroids and ACTH on sensory systems. *Prog Brain Res* 32:270-294.

- Herman JP, Patel PD, Akil H, Watson SJ (1989a) Localization and regulation of glucocorticoid and mineralocorticoid receptor messenger RNAs in the hippocampal formation of the rat. *Mol Endocrinol* 3:1886-1894.
- Herman JP, Schafer MK, Young EA, Thompson R, Douglass J, Akil H, Watson SJ (1989b) Evidence for hippocampal regulation of neuroendocrine neurons of the hypothalamo-pituitary-adrenocortical axis. *J Neurosci* 9:3072-3082.
- Herman JP, Cullinan WE, Young EA, Akil H, Watson SJ (1992) Selective forebrain fiber tract lesions implicate ventral hippocampal structures in tonic regulation of paraventricular nucleus corticotropin-releasing hormone (CRH) and arginine vasopressin (AVP) mRNA expression. *Brain Res* 592:228-238.
- Herman JP (1993) Regulation of adrenocorticosteroid receptor mRNA expression in the central nervous system. *Cell Mol Neurobiol* 13:349-372.
- Herman JP, Watson SJ (1995) Stress regulation of mineralocorticoid receptor heteronuclear RNA in rat hippocampus. *Brain Res* 677:243-249.
- Hervé D, Lévi-Strauss M, Marey-Semper I, Verney C, Tassin JP, Glowinski J, Girault JA (1993) G_{olf} and G_s in rat brain basal ganglia: possible involvement of G_{olf} in the coupling of dopamine D_1 receptor with adenylyl cyclase. *J Neurosci* 13:2237-2248.
- Ho BY, Karschin A, Branchek T, Davidson N, Lester HA (1992) The role of conserved aspartate and serine residues in ligand binding and in function of the 5-HT_{1A} receptor: a site-directed mutation study. *FEBS Lett* 312:259-262.
- Hollenberg SM, Weinberger C, Ong ES, Cerelli G, Oro A, Lebo R, Rosenfeld MG, Evans RM (1985) Primary structure and expression of a functional human glucocorticoid receptor cDNA. *Nature (London)* 318:635-641.
- Hollenberg SM, Giguere V, Segui P, Evans RM (1987) Colocalization of DNA-binding and transcriptional activation functions in the human glucocorticoid receptor. *Cell* 49:39-46.
- Hollenberg SM, Evans RM (1988) Multiple and cooperative trans-activation domains of the human glucocorticoid receptor. *Cell* 55:899-906.

- Holmes MC, Antoni FA, Catt KJ, Aguilera G (1986) Predominant release of vasopressin vs. corticotropin-releasing factor from the isolated median eminence after adrenalectomy. *Neuroendocrinology* 43:245-251.
- Holmes MC, French KL, Seckl JR (1995a) Modulation of serotonin and corticosteroid receptor gene expression in the rat hippocampus with circadian rhythm and stress. *Mol Brain Res*:186-192.
- Holmes MC, Yau JL, French KL, Seckl JR (1995b) The effect of adrenalectomy on 5-hydroxytryptamine and corticosteroid receptor subtype messenger RNA expression in rat hippocampus. *Neuroscience* 64:327-337.
- Horisberger JD, Rossier BC (1992) Aldosterone regulation of gene transcription leading to control of ion transport. *Hypertension* 19:221-227.
- Howard KJ, Distelhorst CW (1988a) Evidence for intracellular association of the glucocorticoid receptor with the 90-kDa heat shock protein. *J Biol Chem* 263:3474-3481.
- Howard KJ, Distelhorst CW (1988b) Effect of the 90 kDa heat shock protein, HSP90, on glucocorticoid receptor binding to DNA-cellulose. *Biochem Biophys Res Commun* 151:1226-1232.
- Idziorek T, Formstecher P, Danze PM, Sablonniere B, Lustenberger P, Richard C, Dumur V, Dautrevaux M (1985) Characterization of the purified molybdate-stabilized glucocorticoid receptor from rat liver. An in vitro transformable complex. *Eur J Biochem* 153:65-74.
- Illek B, Fischer H, Clauss W (1990) Aldosterone regulation of basolateral potassium channels in alveolar epithelium. *Am J Physiol* 259:L230-L237.
- Ishizuka N, Weber J, Amaral DG (1990) Organization of intrahippocampal projections originating from CA3 pyramidal cells in the rat. *J Comp Neurol* 295:580-623.
- Iismaa TP, Shine J (1992) G protein-coupled receptors. [Review]. *Curr Opin Cell Biol* 4:195-202.
- Issa AM, Rowe W, Gauthier S, Meaney MJ (1990) Hypothalamic-pituitary-adrenal activity in aged, cognitively impaired and cognitively unimpaired rats. *J Neurosci* 10:3247-3254.

Jacobson L, Sapolsky RM (1991) The role of the hippocampus in feedback regulation of the hypothalamic-pituitary-adrenocortical axis. *Endocrin Rev* 12:118-134.

Jakeman LB, To ZP, Eglen RM, Wong EH, Bonhaus DW (1994) Quantitative autoradiography of 5-HT₄ receptors in brains of three species using two structurally distinct radioligands, [³H]GR113808 and [³H]BIMU-1. *Neuropharmacology* 33:1027-1038.

Jaarsma D, Postema F, Korf J (1992) Time course and distribution of neuronal degeneration in the dentate gyrus of rat after adrenalectomy: A silver impregnation study. *Hippocampus* 2:143-150.

Jeffcoate WJ, Silverstone JT, Edwards CRW, Besser GM (1979) Psychiatric manifestations of Cushing's syndrome: response to lowering of plasma cortisol. *Q J Med* 68:465-472.

Jefferys D, Copolov D, Irby D, Funder J (1983) Behavioural effect of adrenalectomy: reversal by glucocorticoids or [D-Ala²,Met⁵]enkephalinamide. *Eur J Pharmacol* 92:99-103.

Jensen MS, Azouz R, Yaari Y (1996) Spike after-depolarization and burst generation in adult rat hippocampal CA1 pyramidal cells. *J Physiol (London)* 492:199-210.

Jensen TS, Genefke IK, Hyldebrandt N, Pedersen H, Petersen HD, Weile, B. (1982) Cerebral atrophy in young torture victims. *N Engl J Med* 307:1341

Joëls M, de Kloet ER (1989) Effects of glucocorticoids and norepinephrine on the excitability in the hippocampus. *Science* 245:1502-1505.

Joëls M, de Kloet ER (1990) Mineralocorticoid receptor-mediated changes in membrane properties of rat CA1 pyramidal neurons in vitro. *Proc Natl Acad Sci U S A* 87:4495-4498.

Joëls M, Heslen W, de Kloet ER (1991) Mineralocorticoid hormones suppress serotonin-induced hyperpolarization of rat hippocampal CA1 neurons. *J Neurosci* 11:2288-2294.

Joëls M, de Kloet ER (1992) Coordinative mineralocorticoid and glucocorticoid receptor-mediated control of responses to serotonin in rat hippocampus. *Neuroendocrinology* 55:344-350.

- Joëls M, de Kloet ER (1993) Corticosteroid actions on amino acid-mediated transmission in rat CA1 hippocampal cells. *J Neurosci* 13:4082-4090.
- Joëls M, Fernhout B (1993) Decreased population spike in CA1 hippocampal area of adrenalectomized rats after repeated synaptic stimulation. *J Neuroendocrinology* 5:537-543.
- Joëls M, de Kloet ER (1994) Mineralocorticoid and glucocorticoid receptors in the brain. Implications for ion permeability and transmitter systems. *Prog Neurobiol* 43:1-36.
- Joëls M, Heslen W, Karst H, de Kloet ER (1994a) Steroids and electrical activity in the brain. *J Steroid Biochem Mol Biol* 49:391-398.
- Joëls M, Karst H, Heslen W, Wadman WJ (1994b) Gene-mediated control of hippocampal neuronal excitability. *Ann N Y Acad Sci* 746:166-75.
- Jordan F (1990) Localization of G-protein in rat occipital cerebral cortex. *Brain Res Bull* 25:155-158.
- Kabbaj M, Piazza PV, Simon H, Le Moal M, Maccari S (1995) Opposite effects on hippocampal corticosteroid receptors induced by stimulation of beta and alpha 1 noradrenergic receptors. *Neuroscience* 66:539-545.
- Kadekaro M, Ito M, Gross PM (1988) Local cerebral glucose utilization is increased in acutely adrenalectomized rats. *Neuroendocrinology* 47:329-334.
- Kalinyak JE, Dorin RI, Hoffman AR, Perlman AJ (1987) Tissue-specific regulation of glucocorticoid receptor mRNA by dexamethasone. *J Biol Chem* 262:10441-10444.
- Kanaho Y, Tsai SC, Adamik R, Hewlett EL, Moss J, Vaughan M (1984) Rhodopsin-enhanced GTPase activity of the inhibitory GTP-binding protein of adenylate cyclase. *J Biol Chem* 259:7378-7381.
- Kaneko M, Hiroshige T (1978a) Site of fast, rate-sensitive feedback inhibition of adrenocorticotropin secretion during stress. *Am J Physiol* 234:R46-R51.
- Kaneko M, Hiroshige T (1978b) Fast, rate-sensitive corticosteroid negative feedback during stress. *Am J Physiol* 234:R39-R45.

- Kant GJ, Meyerhoff JL, Jarrard LE (1984) Biochemical indices of reactivity and habituation in rats with hippocampal lesions. *Pharmacol Biochem Behav* 20:793-797.
- Karst H, Wadman WJ, Joëls M (1993) Long-term control by corticosteroids of the inward rectifier in rat CA1 pyramidal neurons, in vitro. *Brain Res* 612:172-179.
- Karst H, Wadman WJ, Joëls M (1994) Corticosteroid receptor-dependent modulation of calcium currents in rat hippocampal CA1 neurons. *Brain Res* 649:234-242.
- Kawai Y, Arinze IJ (1993) Glucocorticoid regulation of G-protein subunits in neonatal liver. *Mol Cell Endocrinol* 90:203-209.
- Kawakami M, Seto K, Terasawa E, Yoshida K, Miyamoto T, Sekiguchi M, Hattori Y (1968) Influence of electrical stimulation and lesion in limbic structure upon biosynthesis of adrenocorticoid in the rabbit. *Neuroendocrinology* 3:337-348.
- Keller-Wood ME, Dallman MF (1984) Corticosteroid inhibition of ACTH secretion. *Endocrine Rev* 5:1-24.
- Kelly WF, Checkley SA, Bender DA (1980) Cushing's syndrome, tryptophan and depression. *Br J Psychiatry* 136:125-132.
- Kelly WF, Checkley SA, Bender DA, Mashiter K (1983) Cushing's syndrome and depression--a prospective study of 26 patients. *Br J Psychiatry* 142:16-19.
- Kendal DA, Robinson JP (1990) Biochemical and functional correlates of adrenoreceptor function in the central nervous system. In: *The pharmacology of noradrenaline in the CNS* (Heal J, Marsden CA eds), pp 118-140. Oxford Medical Publications.
- Kerr DS, Campbell LW, Hao SY, Landfield PW (1989) Corticosteroid modulation of hippocampal potentials: increased effect with aging. *Science* 245:1505-1509.
- Kerr DS, Campbell LW, Thibault O, Landfield PW (1992) Hippocampal glucocorticoid receptor activation enhances voltage-dependent Ca^{2+} conductances: relevance to brain aging. *Proc Natl Acad Sci USA* 89:8527-8531.
- King BH, Brazell C, Dourish CT, Middlemiss DN (1989) Activation of the 5-HT₂ receptor subtype increases rat plasma ACTH concentration. *Br J Pharmacol* 98:686P

- Kiss JZ, Mezey E, Skirboll L (1984) Corticotropin-releasing factor-immunoreactive neurons of the paraventricular nucleus become vasopressin positive after adrenalectomy. *Proc Natl Acad Sci USA* 81:1854-1858.
- Kitt C, Hohmann C, Coyle JT, Price DL (1994) Cholinergic innervation of mouse forebrain structures. *J Comp Neurol* 341:117-129.
- Kleuss C, Scherübl S, Hescheler J, Schulz G, Wittig B (1993) Selectivity on signal transduction determined by g subunits of heterotrimeric G proteins. *Science* 259:832-834.
- Knowles WD, Schwartzkroin PA (1981a) Local circuit synaptic interactions in hippocampal brain slices. *J Neurosci* 1:318-322.
- Knowles WD, Schwartzkroin PA (1981b) Axonal ramifications of hippocampal CA1 pyramidal cells. *J Neurosci* 1:1236-1241.
- Knowles WD (1992) Normal anatomy and neurophysiology of the hippocampal formation. *J Clin Neurophysiol* 9:252-263.
- Kobayashi T, Ikeda K, Ichikawa T, Abe S, Togashi S, Kumanishi T (1995) Molecular cloning of a mouse G-protein-activated K⁺ channel (mGIRK1) and distinct distributions of three GIRK (GIRK1, 2 and 3) mRNAs in mouse brain. *Biochem Biophys Res Commun* 208:1166-1173
- Kobilka BK, Frielle T, Collins S, Yang-Feng T, Kobilka TS, Francke U, Lefkowitz RJ, Caron MG (1987) An intronless gene encoding a potential member of the family of receptors coupled to guanine nucleotide regulatory proteins. *Nature* 329:75-79.
- Kobilka BK, Kobilka TS, Daniel K, Regan JW, Caron MG, Lefkowitz RJ (1988) Chimeric alpha 2-,beta 2-adrenergic receptors: delineation of domains involved in effector coupling and ligand binding specificity. *Science* 240:1310-1316.
- Koch B, Lutz-Bucher B, Briaud B, Mialhe C (1979) Relationship between ACTH secretion and corticoid binding to specific receptors in perfused adenohipophyses. *Neuroendocrinology* 28:169-177.
- Koenig JJ, Gudelsky GA, Meltzer HY (1987) Stimulation of corticosterone and beta-endorphin secretion in the rat by selective 5-HT receptor subtype activation. *Eur J Pharmacol* 137:1-8.

Koenig JJ, Meltzer HY, Gudelsky GA (1988) 5-Hydroxytryptamine_{1A} receptor-mediated effects of buspirone, gepirone and ipsapirone. *Pharmacol Biochem Behav* 29:711-715.

Koeppen BM, Biagi BA, Giebisch GH (1983) Intracellular microelectrode characterization of the rabbit cortical collecting duct. *Am J Physiol* 244:F35-F47.

Konnerth A, Lux HD, Heinemann U (1986) Ionic properties of burst generation in hippocampal pyramidal cell soma 'in vitro'. In: *Experimental Brain Research, series 14* (Heinemann U, Klee M, Neher E, Singer W eds), pp 368-374. Berlin, Heidelberg: Springer-Verlag.

Kovacs K, Kiss JZ, Makara GB (1986) Glucocorticoid implants around the hypothalamic paraventricular nucleus prevent the increase of corticotropin-releasing factor and arginine vasopressin immunostaining induced by adrenalectomy. *Neuroendocrinology* 44:229-234.

Kovacs KJ, Makara GB (1988) Corticosterone and dexamethasone act at different brain sites to inhibit adrenalectomy-induced adrenocorticotropin hypersecretion. *Brain Res* 474:205-210.

Kozasa T, Itoh H, Tsukamoto T, Kaziro Y (1988) Isolation and characterization of the human Gsa gene. *Proc Natl Acad Sci USA* 85:2081-2085.

Kraus-Friedmann N (1984) Hormonal regulation of hepatic gluconeogenesis. *Physiol Rev* 64:170-259.

Krozowski ZS, Funder JW (1983) Renal mineralocorticoid receptors and hippocampal corticosterone-binding species have identical intrinsic steroid specificity. *Proc Natl Acad Sci USA* 80:6056-6060.

Kuroda Y, Watanabe Y, Albeck DS, Hastings NB, McEwen BS (1994) Effects of adrenalectomy and type I or type II glucocorticoid receptor activation on 5-HT_{1A} and 5-HT₂ receptor binding and 5-HT transporter mRNA expression in rat brain. *Brain Res* 648:157-161.

Kwak SP, Morano MI, Young EA, Watson SJ, Akil H (1993) Diurnal CRH mRNA rhythm in the hypothalamus: decreased expression in the evening is not dependent on endogenous glucocorticoids. *Neuroendocrinology* 57:96-105.

- LaFond RE, Kennedy SW, Harrison RW, Vilee CA (1988) Immunocytochemical localization of glucocorticoid receptors in cells, cytoplasts, and nucleoplasts. *Exp Cell Res* 175:52-62.
- Lahav M, Dietz T, Edelman IS (1973) The action of aldosterone on sodium transport: further studies with inhibitors of RNA and protein synthesis. *Endocrinology* 92:1685-1699.
- Laitinen LA, Laitinen A (1996) Remodeling of asthmatic airways by glucocorticosteroids. *J Allergy Clin Immunol* 97:153-158.
- Lamers WH, Hanson RW, Meisner HM (1982) cAMP stimulates transcription of the gene for cytosolic phosphoenolpyruvate carboxykinase in rat liver nuclei. *Proc Natl Acad Sci USA* 79:5137-5141.
- Lancaster B, Nicoll RA (1987) Properties of two calcium-activated hyperpolarizations in rat hippocampal neurones. *J Physiol (Lond)* 389:187-203.
- Landfield PW (1987) Modulation of brain aging correlates by long-term alterations of adrenal steroids and neurally-active peptides. *Prog Brain Res* 72:279-300.
- Landfield PW, Eldridge JC (1994) Evolving aspects of the glucocorticoid hypothesis of brain aging: hormonal modulation of neuronal calcium homeostasis. *Neurobiol Aging* 15:579-588.
- Largent B, Jones DT, Reed R, Pearson CA, Snyder S (1988) G protein mRNA mapped in rat brain by in situ hybridization. *Proc Natl Acad Sci USA* 85:2864-2868.
- Lesage F, Duprat F, Fink M, Guillemare E, Coppola T, Lazdunski M, Hugnot JP (1994) Cloning provides evidence for a family of inward rectifier and G-protein coupled K⁺ channels in the brain. *FEBS Letters* 353:37-42.
- Lesage F, Guillemare E, Fink M, Duprat F, Heurteaux C, Fosset M, Romey G, Barhanin J, Lazdunski M (1995) Molecular properties of neuronal G-protein-activated inwardly rectifying K⁺ channels. *J Biol Chem* 270:28660-28667.
- Lesch KP, Lerer B (1991) The 5-HT receptor--G-protein--effector system complex in depression. I. Effect of glucocorticoids. *J Neural Trans - General Section* 84:3-18.

- Lesch KP, Majni HK (1992) Signal-transducing G proteins and antidepressant drugs: evidence for modulation of a subunit gene expression in rat brain. *Biol Psychiatry* 32: 549-579.
- Levin N, Shinsako J, Dallman MF (1988) Corticosterone acts on the brain to inhibit adrenalectomy-induced adrenocorticotropin secretion. *Endocrinology* 122:694-701.
- Liposits Z, Phelix C, Paull WK (1987) Synaptic interaction of serotonergic axons and corticotropin releasing factor (CRF) synthesizing neurons in the hypothalamic paraventricular nucleus of the rat. A light and electron microscopic immunocytochemical study. *Histochemistry* 86:541-549.
- Liposits Z (1993) Ultrastructure of hypothalamic paraventricular neurons. *Critical Rev Neurobiol* 7:89-162.
- Lopez-Gonzalez MA, Calvo JR, Rubio A, Goberna R, Guerrero JM (1991) Characterization of melatonin binding sites in the harderian gland and median eminence of the rat. *Life Sci* 48:1165-1171.
- Lorens SA, Van de Kar LD (1987) Differential effects of serotonin (5-HT_{1A} and 5-HT₂) agonists and antagonists on renin and corticosterone secretion. *Neuroendocrinology* 45:305-310.
- Lovenberg TW, Baron BM, de Lecea L, Miller JD, Prosser RA, Rea MA, Foye PE, Racke M, Slone AL, Siegel BW (1993) A novel adenylyl cyclase-activating serotonin receptor (5-HT₇) implicated in the regulation of mammalian circadian rhythms. *Neuron* 11:449-458.
- Lowy MT (1991) Corticosterone regulation of brain and lymphoid corticosteroid receptors. *J Steroid Biochem Mol Biol* 39:147-154.
- Luine V, Villegas M, Martinez C, McEwen BS (1994a) Repeated stress causes reversible impairments of spatial memory performance. *Brain Res* 639:167-170.
- Luine V, Villegas M, Martinez C, McEwen BS (1994b) Stress-dependent impairments of spatial memory. Role of 5-HT. *Ann N Y Acad Sci* 746:403-404.
- Lustenberger P, Blanchardie P, Denis M, Formstecher P, Orsonneau JL (1985) Nontransformed rabbit liver glucocorticoid receptor: purification, characterization and transformation. *Biochimie* 67:1267-1278.

Luttge WG, Rupp ME, Davda MM (1989) Aldosterone-stimulated down-regulation of both type I and type II adrenocorticosteroid receptors in mouse brain is mediated via type I receptors. *Endocrinology* 125:817-824.

Maccari S, Le Moal M, Angelucci L, Mormede P (1990) Influence of 6-OHDA lesion of central noradrenergic systems on corticosteroid receptors and neuroendocrine responses to stress. *Brain Res* 533:60-65.

Maccari S, Mormede P, Piazza PV, Simon H, Angelucci L, Le Moal M (1992a) Hippocampal type I and type II corticosteroid receptors are modulated by central noradrenergic systems. *Psychoneuroendocrinology* 17:103-112.

Maccari S, Piazza PV, Rouge-Pont F, Angelucci L, Simon H, Le Moal M (1992b) Noradrenergic regulation of type-I and type-II corticosteroid receptors in amygdala and hypothalamus. *Brain Res* 587:313-318.

McNeil TH, Masters JN, Finch CE (1991) Effect of chronic adrenalectomy on neuron loss and distribution of sulphated glycoprotein-2 in the dentate gyrus of prepubertal rats. *Exp Neurol* 111:140-144.

Madison DV, Nicoll RA (1984) Control of the repetitive discharge of rat CA1 pyramidal neurones in vitro. *J Physiol (Lond)* 354:319-331.

Magarinos AM, Somoza G, De Nicola AF (1987) Glucocorticoid negative feedback and glucocorticoid receptors after hippocampectomy in rats. *Horm Metab Res* 19:105-109.

Magarinos AM, Ferrini M, De Nicola AF (1989) Corticosteroid receptors and glucocorticoid content in microdissected brain regions: correlative aspects. *Neuroendocrinology* 50:673-678.

Magarinos AM, McEwen BS (1995a) Stress-induced atrophy of apical dendrites of hippocampal CA3c neurons: involvement of glucocorticoid secretion and excitatory amino acid receptors. *Neuroscience* 69:89-98.

Magarinos AM, McEwen BS (1995b) Stress-induced atrophy of apical dendrites of hippocampal CA3c neurons: comparison of stressors. *Neuroscience* 69:83-88.

Makara GB, Stark E (1976) The effects of cholinomimetic drugs and atropine on ACTH release. *Neuroendocrinology* 21:31-41.

Malbon CC, Rapiejko PJ, Watkins DC (1988) Permissive hormone regulation of hormone-sensitive effector systems. *Trends Pharmacol Sci* 9:33-36.

Mangili G, Motta M, Martini L (1966) Control of adrenocorticotrophic hormone secretion. In: *Neuroendocrinology*, vol. 1 (Martini L, Ganong WF eds), pp 297 New York: Academic.

Masukawa LM, Benardo LS, Prince DA (1982) Variations in electrophysiological properties of hippocampal neurons in different subfields. *Brain Res* 242:341-344.

Mautete C, Nguyen Q-T, Miledi R (1993) mRNAs coding for neurotransmitter receptors in rabbit and rat visual areas. *J Neurosci Res* 35:652-663.

Mayer M, Shafir E, Kaiser N, Milholland RJ, Rosen F (1976) Interaction of glucocorticoid hormones with rat skeletal muscle: catabolic effects and hormone binding. *Metabolism* 25:157-167.

McCarthy GF, Beaudet A, Tannenbaum GS (1992) Colocalization of somatostatin receptors and growth hormone-releasing factor immunoreactivity in neurons of the rat arcuate nucleus. *Neuroendocrinology* 56:18-24.

McCormick DA (1992) Neurotransmitter actions in the thalamus and cerebral cortex. *J Clin Neurophys.*, 9:212-223.

McEwen BS, Weiss JM, Schwartz LS (1968) Selective retention of corticosterone by limbic structures in rat brain. *Nature (Lond)* 220:911-912.

McEwen BS, Weiss JM, Schwartz LS (1969) Uptake of corticosterone by rat brain and its concentration by certain limbic structures. *Brain Res* 16:227-241

McEwen BS, Plapinger L (1970) Association of [³H]corticosterone-1,2 with macromolecules extracted from brain cell nuclei. *Nature (London)* 226:263-265.

McEwen BS, Weiss JM, Schwartz LS (1970) Retention of corticosterone by cell nuclei from brain regions of adrenalectomized rats. *Brain Res* 17:471-482.

McEwen BS, Magnus C, Wallach G (1972) Soluble corticosterone-binding macromolecules extracted from rat brain. *Endocrinology* 90:217-226.

- McEwen BS, Brinton RE (1987) Neuroendocrine aspects of adaptation. *Prog Brain Res* 72:11-26.
- McEwen BS, Cameron H, Chao HM, Gould E, Magarinos AM, Watanabe Y (1993) Adrenal steroids and plasticity of hippocampal neurons: toward an understanding of underlying cellular and molecular mechanisms. *Cell Mol Neurobiol* 13:457-482.
- McEwen BS, Sapolsky RM (1995) Stress and cognitive function. *Curr Opin Neurobiol* 5:205-216.
- McEwen BS (1996) Gonadal and adrenal steroids regulate neurochemical and structural plasticity of the hippocampus via cellular mechanisms involving NMDA receptors. *Cell Mol Neurobiol* 16:103-116.
- McKittrick CR, Blanchard DC, Blanchard RJ, McEwen BS, Sakai RR (1995) Serotonin receptor binding in a colony model of chronic social stress. *Biol Psychiatry* 37:383-393.
- Meaney MJ, Aitken DH, Bodnoff SR, Iny LJ, Tatarewicz JE, Sapolsky RM (1985) Early postnatal handling alters glucocorticoid receptor concentrations in selected brain regions. *Behav Neurosci* 99:765-770.
- Meaney MJ, Diorio J, Francis D, Larocque S, O'Donnell D, Smythe JW, Sharma S, Tannenbaum B (1998) Environmental regulation of the development of glucocorticoid receptor systems in the rat forebrain. The role of serotonin. *Ann N Y Acad Sci* 746:260-73; discussion 274.
- Meijer OC, de Kloet ER (1994) Corticosterone suppresses the expression of 5-HT_{1A} receptor mRNA in rat dentate gyrus. *Eur J Pharmacol* 266:255-261.
- Mendel DB, Bodwell JE, Gametchu B, Harrison RW, Munck A (1986) Molybdate-stabilized nonactivated glucocorticoid-receptor complexes contain a 90-kDa non-steroid-binding phosphoprotein that is lost on activation. *J Biol Chem* 261:3758-3763.
- Mendelson SD, McEwen BS (1992) Autoradiographic analyses of the effects of adrenalectomy and corticosterone on 5-HT_{1A} and 5-HT_{1B} receptors in the dorsal hippocampus and cortex of the rat. *Neuroendocrinology* 55:444-450.

Mendelson SD, McEwen BS (1992) Quantitative autoradiographic analyses of the time course and reversibility of corticosterone-induced decreases in binding at 5-HT_{1A} receptors in rat forebrain. *Neuroendocrinology* 56:881-888.

Meyerhof W, Obermuller F, Fehr S, Richter D (1993) A novel rat serotonin receptor: primary structure, pharmacology, and expression pattern in distinct brain regions. *DNA Cell Biol* 12:401-409.

Micco DJ, Jr., McEwen BS (1980) Glucocorticoids, the hippocampus, and behavior: interactive relation between task activation and steroid hormone binding specificity. *J Comp Physiol Psychol* 94:624-633.

Miesfeld R, Rusconi S, Godowski PJ, Maler BA, Okret S, Wikstrom AC, Yamamoto KR (1986) Genetic complementation of a glucocorticoid receptor deficiency by expression of cloned receptor cDNA. *Cell* 46:389-399.

Miesfeld R, Godowski PJ, Maler BA, Yamamoto KR (1987) Glucocorticoid receptor mutants that define a small region sufficient for enhancer activation. *Science* 236:423-427.

Migliore M, Cook EP, Jaffe DB, Turner DA, Johnston D (1995) Computer simulations of morphologically reconstructed CA3 hippocampal neurons. *J Neurophysiol* 73:1157-1168.

Miles R, Wong RK (1986) Excitatory synaptic interactions between CA3 neurones in the guinea-pig hippocampus. *J Physiol (Lond)* 373:397-418.

Mitchell JB, Rowe W, Boksa P, Meaney MJ (1990) Serotonin regulates type II corticosteroid receptor binding in hippocampal cell cultures. *J Neurosci* 10:1745-1752.

Mitchell JB, Betito K, Rowe W, Boksa P, Meaney MJ (1992) Serotonergic regulation of type II corticosteroid receptor binding in hippocampal cell cultures: evidence for the importance of serotonin-induced changes in cAMP levels. *Neuroscience* 48:631-639.

Moberg GP, Scapagnini U, Groot J, de, Ganong WF (1971) Effect of sectioning the fornix on diurnal fluctuation in plasma corticosterone levels in the rats. *Neuroendocrinology* 7:11-15.

Moguilewsky M, Raynaud JP (1980) Evidence for a specific mineralocorticoid receptor in rat pituitary and brain. *J Steroid Biochem* 12:309-314.

- Molliver ME (1987) Serotonergic neuronal systems: what their anatomic organization tells us about function. *J Clin Psychopharmacol* 7:3S-23S.
- Moore RY, Bloom FE (1979) Central catecholamine neuron systems: anatomy and physiology of the norepinephrine and epinephrine systems. *Ann Rev Neurosci* 2:113-168.
- Mulder GH, Smelik PG (1977) A superfusion system technique for the study of the sites of action of glucocorticoids in the rat hypothalamus-pituitary-adrenal system in vitro. I. Pituitary cell superfusion. *Endocrinology* 100:1142-1152.
- Munck A, Guyre PM, Holbrook NJ (1984) Physiological functions of glucocorticoids in stress and their relation to pharmacological actions. *Endocrine Rev* 5:25-44.
- Munck A, Guyre PM (1986) Glucocorticoid physiology, pharmacology and stress. *Adv Exp Med Biol* 196:81-96.
- Murphy BE (1991a) Steroids and depression. *J Steroid Biochem Mol Biol* 38:537-559.
- Murphy BE (1991b) Treatment of major depression with steroid suppressive drugs. *J Steroid Biochem Mol Biol* 39:239-244.
- Murphy BE, Dhar V, Ghadirian AM, Chouinard G, Keller R (1991) Response to steroid suppression in major depression resistant to antidepressant therapy. *J Clin Psychopharmacol* 11:121-126.
- Nieman LK, Chrousos GP, Kellner C, Spitz IM, Nisula BC, Cutler GB, Merriam GR, Bardin CW, Loriaux DL (1985) Successful treatment of Cushing's syndrome with the glucocorticoid antagonist RU 486. *J Clin Endocrinol Metab* 61:536-540.
- Navon SE, Fung BK (1987) Characterization of transducin from bovine retinal rod outer segments. Participation of the amino-terminal region of T alpha in subunit interaction. *J Biol Chem* 262:15746-15751.
- Nishida A, Kaiya H, Kanaho Y, Nozawa Y (1991) Distinct cellular expression of pertussis toxin-sensitive GTP-binding proteins in rat cerebellum. *Neurosci Lett* 124:133-136.

Northup JK, Smigel MD, Sternweis PC, Gilman AG (1983a) The subunits of the stimulatory regulatory component of adenylate cyclase. Resolution of the activated 45,000-dalton (alpha) subunit. *J Biol Chem* 258:11369-11376.

Northup JK, Sternweis PC, Gilman AG (1983b) The subunits of the stimulatory regulatory component of adenylate cyclase. Resolution, activity, and properties of the 35,000-dalton (beta) subunit. *J Biol Chem* 258:11361-11368.

Novotney S, Lowy MT (1995) Short-term and long-term effects of p-chloroamphetamine on hippocampal serotonin and corticosteroid receptor levels. *Brain Res* 684:19-25.

Nunez A, Garcia-Austt E, Buno W (1990) Slow intrinsic spikes recorded in vivo in rat CA1-CA3 hippocampal pyramidal neurons. *Exp Neurol* 109:294-299.

Nyakas C, de Kloet ER, Bohus B (1979) Hippocampal function and putative corticosterone receptors. Effect of septal lesions. *Neuroendocrinology* 29:301-312.

O'Donnell D, Larocque S, Seckl JR, Meaney MJ (1994) Postnatal handling alters glucocorticoid, but not mineralocorticoid messenger RNA expression in the hippocampus of adult rats. *Brain Res Mol Brain Res* 26:242-248.

O'Donnell D, Meaney MJ (1994) Aldosterone modulates glucocorticoid receptor binding in hippocampal cell cultures via the mineralocorticoid receptor. *Brain Res* 636:49-54.

O'Dowd BF, Hnatowich M, Regan JW, Leader WM, Caron MG, Lefkowitz RJ (1988) Site-directed mutagenesis of the cytoplasmic domains of the human beta 2-adrenergic receptor. Localization of regions involved in G protein-receptor coupling. *J Biol Chem* 263:15985-15992.

O'Neil RG (1990) Aldosterone regulation of sodium and potassium transport in the cortical collecting duct. *Sem Nephrol* 10:365-374.

Oh U, Ho YK, Kim D (1995) Modulation of the serotonin-activated K^+ channel by G protein subunits and nucleotides in rat hippocampal neurons. *J Membr Biol* 147:241-253.

Oitzl MS, de Kloet ER (1992) Selective corticosteroid antagonists modulate specific aspects of spatial orientation learning. *Behav Neurosci* 106:62-71.

Oitzl MS, Fluttert M, de Kloet ER (1994) The effect of corticosterone on reactivity to spatial novelty is mediated by central mineralocorticosteroid receptors. *Eur J Neurosci* 6:1072-1079.

Okret S, Wikstrom AC, Gustafsson JA (1985) Molybdate-stabilized glucocorticoid receptor: evidence for a receptor heteromer. *Biochemistry* 24:6581-6586.

Okuhara DY, Beck SG (1994) 5-HT_{1A} receptor linked to inward-rectifying potassium current in hippocampal CA3 pyramidal cells. *J Neurophysiol* 71:2161-2167.

Okuhara DY, Beck SG, Muma NA (1996a) Corticosterone alters G protein α -subunit levels in the rat hippocampus. *Brain Res* Accepted

Okuhara DY, Beck SG (1996b) Corticosteroids alter pyramidal cell electrophysiological characteristics in hippocampal subfield CA3. Submitted

Okuhara DY, Lee JM, Beck SG, Muma NA (1996c) Differential immunohistochemical labeling of G_s, G_{i1 and 2}, and G_o α -subunits in rat forebrain. *Synapse* 23:246-257.

Otmakhov NA, Bragin AG (1982) Effects of norepinephrine and serotonin upon spontaneous activity and responses to mossy fiber stimulation of CA3 neurons in hippocampal slices. *Brain Res* 253:173-183.

Palka Y, Coyer D, Critchlow V (1969) Effects of isolation of medial basal hypothalamus on pituitary-adrenal and pituitary-ovarian functions. *Neuroendocrinology* 5:333-349.

Palkovits M, Saavedra JM, Jacobowitz DM, Kizer JS, Zaborszky L, Brownstein MJ (1977) Serotonergic innervation of the forebrain: effect of lesions on serotonin and tryptophan hydroxylase levels. *Brain Res* 130:121-134.

Papamichail M, Tsokos G, Tsawdaroglou N, Sekeris CE (1980) Immunocytochemical demonstration of glucocorticoid receptors in different cell types and their translocation from the cytoplasm to the cell nucleus in the presence of dexamethasone. *Exp Cell Res* 125:490-493.

Patel PD, Sherman TG, Goldman DJ, Watson SJ (1989) Molecular cloning of a mineralocorticoid (type I) receptor complementary DNA from rat hippocampus. *Mol Endocrinol* 3:1877-1885.

- Paull WK, Gibbs FP (1983) The corticotropin releasing factor (CRF) neurosecretory system in intact, adrenalectomized, and adrenalectomized-dexamethasone treated rats. An immunocytochemical analysis. *Histochemistry* 78:303-316.
- Pazos A, Palacios JM (1985) Quantitative autoradiographic mapping of serotonin receptors in the rat brain. I. Serotonin-1 receptors. *Brain Res* 346:205-230.
- Pazos A, Hoyer D, Dietl MM, Palacios JM (1988) Autoradiography of serotonin receptors. In: *Neural serotonin* (Osborne NN, Hamon M eds), pp 57-92. Chichester: Wiley.
- Pearce D (1994) A mechanistic basis for distinct mineralocorticoid and glucocorticoid receptor transcriptional specificities. *Steroids* 59:153-159.
- Peiffer A, Lapointe B, Barden N (1991) Hormonal regulation of type II glucocorticoid receptor messenger ribonucleic acid in rat brain. *Endocrinology* 129:2166-2174.
- Péraldi S, Dao NT, Brabet P, Homburger V, Rouot B, Toutant M, Bouille C, Assenmacher I, Bockaert J, Gabrion J (1989) Apical localization of the alpha subunit of GTP-binding protein G_o in choroidal and ciliated ependymocytes. *J Neurosci* 9:806-814.
- Peters A, Jones E (1984) Classification of cortical neurons. In: *Cerebral cortex* (Jones E, Peters A eds), pp 107-121. New York: Plenum Press.
- Phelps CP, Lengvari I, Carrillo AJ, Sawyer CH (1978) Changes in diurnal fluctuations of plasma thyroid stimulating hormone and corticosterone following anterior hypothalamic deafferentation in the rat. *Brain Res* 141:283-292.
- Picard D, Yamamoto KR (1987) Two signals mediate hormone-dependent nuclear localization of the glucocorticoid receptor. *EMBO Journal* 6:3333-3340.
- Pilkis SJ, Granner DK (1992) Molecular physiology of the regulation of hepatic gluconeogenesis and glycolysis. *Ann Rev Physiol* 54:885-909.
- Plotsky PM (1985) Hypophyseotropic regulation of adenohipophyseal adrenocorticotropin secretion. *Federation Proceedings* 44:207-213.

Plotsky PM, Bruhn TO, Vale W (1985) Hypophysiotropic regulation of adrenocorticotropin secretion in response to insulin-induced hypoglycemia. *Endocrinology* 117:323-329.

Plotsky PM (1987) Facilitation of immunoreactive corticotropin-releasing factor secretion into the hypophysial-portal circulation after activation of catecholaminergic pathways or central norepinephrine injection. *Endocrinology* 121:924-930.

Plotsky PM, Otto S, Sutton S (1987) Neurotransmitter modulation of corticotropin releasing factor secretion into the hypophysial-portal circulation. *Life Sci* 41:1311-1317.

Plotsky PM, Sawchenko PE (1987) Hypophysial-portal plasma levels, median eminence content, and immunohistochemical staining of corticotropin-releasing factor, arginine vasopressin, and oxytocin after pharmacological adrenalectomy. *Endocrinology* 120:1361-1369.

Plotsky PM, Cunningham ET, Jr., Widmaier EP (1989) Catecholaminergic modulation of corticotropin-releasing factor and adrenocorticotropin secretion. *Endocrine Rev* 10:437-458.

Ponce A, Bueno E, Kentros C, Vega-Saenz de Miera E, Chow A, Hillman, D, Chen S, Zhu L, Wu MB, Wu X, Rudy B, Thornhill WB (1996) G-protein-gated inward rectifier K^+ channel proteins (GIRK1) are present in the soma and dendrites as well as in nerve terminals of specific neurons in the brain. *J Neurosci* 16:1990-2001.

Radja F, Laporte A-M, Daval G, Verge D, Gozlan H, Hamon M (1991) Autoradiography of serotonin receptor subtypes in the central nervous system. *Neurochem Int* 18:1-15.

Rall W (1977) Core conductor theory and cable properties of neurons. In: *Handbook of Physiology, Section I - The Nervous System* (Kandel E ed), pp 39-97. Baltimore: Williams & Wilkins.

Ransom BR, Sontheimer H, (1992) The Neurophysiology of Glial Cells. *J Clin Neurophys* 9:224-251.

Raskind MA, Peskind ER, Wilkinson CW (1994) Hypothalamic-pituitary-adrenal axis regulation and human aging. *Ann N Y Acad Sci* 746:327-335.

- Ratka A, Sutanto W, Bloemers M, de Kloet ER (1989) On the role of brain mineralocorticoid (type I) and glucocorticoid (type II) receptors in neuroendocrine regulation. *Neuroendocrinology* 50:117-123.
- Raymond JR (1991) Protein kinase C induces phosphorylation and desensitization of the human 5-HT_{1A} receptor. *J Biol Chem* 266:14747-14753.
- Rees HD, Stumpf WE, Sar M (1975) Autoradiographic studies with ³H-dexamethasone in the rat brain and pituitary. In: *Anatomical endocrinology* (Stumpf WE, Grant LA eds), pp 262-269. Basel: Krager.
- Reiheld CT, Teyler TJ, Vardaris RM (1984) Effects of corticosterone on the electrophysiology of hippocampal CA1 pyramidal cells in vitro. *Brain Res Bull* 12:349-353.
- Renaud LP, Aleen AM, Cunningham T, Jarvis CR, Johnston SA, Nissen R, Sullivan MJ, Van Vulpen E, Yang CR (1992) Synaptic and neurotransmitter regulation of activity in mammalian hypothalamic magnocellular neurosecretory cells. *Prog Brain Res* 92:277-288.
- Reppert SM, Weaver DR, Ebisawa T (1994) Cloning and characterization of a mammalian melatonin receptor that mediates reproductive and circadian responses. *Neuron* 13:1177-1185.
- Retiene K, Schulz F (1970) Circadian rhythmicity of hypothalamic CRH and its central nervous regulation. *Horm Metab Res* 2:221-224.
- Reul JM, de Kloet ER (1985) Two receptor systems for corticosterone in rat brain: microdistribution and differential occupation. *Endocrinology* 117:2505-2511.
- Reul JM, de Kloet ER (1986) Anatomical resolution of two types of corticosterone receptor sites in rat brain with in vitro autoradiography and computerized image analysis. *J Steroid Biochem* 24:269-272.
- Reul JM, van den Bosch FR, de Kloet ER (1987a) Relative occupation of type-I and type-II corticosteroid receptors in rat brain following stress and dexamethasone treatment: functional implications. *J Endocrinology* 115:459-467.

Reul JM, van den Bosch FR, de Kloet ER (1987b) Differential response of type I and type II corticosteroid receptors to changes in plasma steroid level and circadian rhythmicity. *Neuroendocrinology* 45:407-412.

Reul JM, Tonnaer JA, de Kloet ER (1988) Neurotrophic ACTH analogue promotes plasticity of type I corticosteroid receptor in brain of senescent male rats. *Neurobiol Aging* 9:253-260.

Reul JM, Pearce PT, Funder JW, Krozowski ZS (1989) Type I and type II corticosteroid receptor gene expression in the rat: effect of adrenalectomy and dexamethasone administration. *Mol Endocrin* 3:1674-1680.

Reul JM, Stec I, Soder M, Holsboer F (1993) Chronic treatment of rats with the antidepressant amitriptyline attenuates the activity of the hypothalamic-pituitary-adrenocortical system. *Endocrinology* 133:312-320.

Rey M, Carlier E, Soumireu-Mourat B (1987a) Effects of corticosterone on hippocampal slice electrophysiology in normal and adrenalectomized BALB/c mice. *Neuroendocrinology* 46:424-429.

Rey M, Carlier E, Soumireu-Mourat B (1987b) Effects of adrenalectomy on in vitro evoked electrophysiological activity of the hippocampus in BALB/c mice. *C R Acad Sci III* 304:167-172.

Rhees RW, Grosser BI, Stevens W (1975) The autoradiographic localization of (³H)dexamethasone in the brain and pituitary of the rat. *Brain Res* 100:151-156.

Rigter H, Veldhuis HD, de Kloet ER (1984) Spatial learning and the hippocampal corticosterone receptor system of old rats: effect of the ACTH4-9 analogue ORG 2766. *Brain Res* 309:393-398.

Robinshaw JD, Smigel MD, Gilman AG (1986) Molecular basis for two forms of the G protein that stimulates adenylate cyclase. *J Biol Chem* 261:9587-9590.

Rodbell M (1990) The role of GTP-binding proteins in signal transduction: From the sublimely simple to the conceptually complex. *Current Topics Cell Reg* 32:1-47.

Rossier BC, Gaggeler HP, Rossier M (1978) Effects of 3'-deoxyadenosine and actinomycin D on RNA synthesis in toad bladder: analysis of response to aldosterone. *J Membr Biol* 41:149-166.

- Rousseau G, Crabbe J (1972) Effects of aldosterone on RNA and protein synthesis in the toad bladder. *Eur J Biochem* 25:550-559.
- Roy EJ, Lynn DM, Bemm CW (1990) Individual variations in hippocampal dentate degeneration following adrenalectomy. *Behav Neurol Biol* 54:330-336.
- Roychowdhury S, Haas H, Anderson EG (1994) 5-HT_{1A} and 5-HT₄ receptor colocalization on hippocampal pyramidal cells. *Neuropharmacology* 33:551-557.
- Rusconi S, Yamamoto KR (1987) Functional dissection of the hormone and DNA binding activities of the glucocorticoid receptor. *EMBO Journal* 6:1309-1315.
- Ruat M, Traiffort E, Leurs R, Tardivel-Lacombe J, Diaz J, Arrang JM, Schwartz JC (1993) Molecular cloning, characterization, and localization of a high-affinity serotonin receptor (5-HT₇) activating cAMP formation. *Proc Natl Acad Sci USA* 90:8547-8551.
- Rutecki PA (1992) Neuronal excitability: voltage-dependent currents and synaptic transmission. *J Clin Neurophysiol* 9:195-211.
- Sah P, Isaacson JS (1995) Channels underlying the slow afterhyperpolarization in hippocampal pyramidal neurons: neurotransmitters modulate the open probability. *Neuron* 15:435-441.
- Sah P, Bekkers JM (1996) Apical dendritic location of slow afterhyperpolarization current in hippocampal pyramidal neurons: Implications for the integration of long-term potentiation. *J Neurosci* 16:4537-4542.
- Saito N, Guitart X, Hayward M, Tallman JF, Duman RS, Nestler EJ (1989) Corticosterone differentially regulates the expression of Gs alpha and Gi alpha messenger RNA and protein in rat cerebral cortex. *Proc Natl Acad Sci U S A* 86:3906-3910.
- Sanchez ER, Toft DO, Schlesinger MJ, Pratt WB (1985) Evidence that the 90-kDa phosphoprotein associated with the untransformed L-cell glucocorticoid receptor is a murine heat shock protein. *J Biol Chem* 260:12398-12401.
- Sanchez ER, Meshinchi S, Schlesinger MJ, Pratt WB (1987a) Demonstration that the 90-kilodalton heat shock protein is bound to the glucocorticoid receptor in its 9S nondeoxynucleic acid binding form. *Mol Endocrinol* 1:908-912.

Sanchez ER, Meshinchi S, Tienrungrroj W, Schlesinger MJ, Toft DO, Pratt WB (1987b) Relationship of the 90-kDa murine heat shock protein to the untransformed and transformed states of the L cell glucocorticoid receptor. *J Biol Chem* 262:6986-6991.

Sanchez ER, Tienrungrroj W, Dalman FC, Lin AL (1987c) Glucocorticoid receptor phosphorylation in mouse L-cells. *J Steroid Biochem* 27:215-225.

Sanchez ER (1990) Hsp56: a novel heat shock protein associated with untransformed steroid receptor complexes. *J Biol Chem* 265:22067-22070.

Sanchez ER, Hirst M, Scherrer LC, Tang HY, Welsh MJ, Harmon JM, Simons SS, Jr., Ringold GM, Pratt WB (1990) Hormone-free mouse glucocorticoid receptors overexpressed in Chinese hamster ovary cells are localized to the nucleus and are associated with both hsp70 and hsp90. *J Biol Chem* 265:20123-20130.

Sansom SC, O'Neil RG (1986) Effects of mineralocorticoids on transport properties of cortical collecting duct basolateral membrane. *Am J Physiol* 251:F743-F757.

Sansom SC, Agulian S, Muto S, Illig V, Giebisch G (1989) K activity of CCD principal cells from normal and DOCA-treated rabbits. *Am J Physiol* 256:F136-F142.

Saphier D, Feldman S (1989) Adrenoceptor specificity in the central regulation of adrenocortical secretion. *Neuropharmacology* 28:1231-1237.

Saphier D, Feldman S (1991) Catecholaminergic projections to tuberoinfundibular neurones of the paraventricular nucleus: III. Effects of adrenoceptor agonists and antagonists. *Brain Res Bull* 26:863-870.

Sapolsky RM, Krey LC, McEwen BS (1983a) Corticosterone receptors decline in a site-specific manner in the aged rat brain. *Brain Res* 289:235-240.

Sapolsky RM, McEwen BS, Rainbow TC (1983b) Quantitative autoradiography of [³H]corticosterone receptors in rat brain. *Brain Res* 271:331-334.

Sapolsky RM, Krey LC, McEwen BS (1984a) Stress down-regulates corticosterone receptors in a site-specific manner in the brain. *Endocrinology* 114:287-292.

Sapolsky RM, Krey LC, McEwen BS (1984b) Glucocorticoid-sensitive hippocampal neurons are involved in terminating the adrenocortical stress response. *Proc Natl Acad Sci USA* 81:6174-6177.

Sapolsky RM (1985) A mechanism for glucocorticoid toxicity in the hippocampus: increased neuronal vulnerability to metabolic insults. *J Neurosci* 5:1228-1232.

Sapolsky RM, McEwen BS (1985) Down-regulation of neural corticosterone receptors by corticosterone and dexamethasone. *Brain Res* 339:161-165.

Sapolsky RM, Krey LC, McEwen BS (1985a) Prolonged glucocorticoid exposure reduces hippocampal neuron number: implications for aging. *J Neurosci* 5:1222-1227.

Sapolsky RM, Meaney MJ, McEwen BS (1985b) The development of the glucocorticoid receptor system in the rat limbic brain. III. Negative-feedback regulation. *Brain Res* 350:169-173.

Sapolsky RM (1986) Glucocorticoid toxicity in the hippocampus: reversal by supplementation with brain fuels. *J Neurosci* 6:2240-2244.

Sapolsky RM, Krey LC, McEwen BS (1986) The neuroendocrinology of stress and aging: the glucocorticoid cascade hypothesis. *Endocrine Rev* 7:284-301.

Sapolsky RM, Armanini MP, Sutton SW, Plotsky PM (1989) Elevation of hypophysial portal concentrations of adrenocorticotropin secretagogues after fornix transection. *Endocrinology* 125:2881-2887.

Sapolsky RM, Armanini MP, Packan DR, Sutton SW, Plotsky PM (1990) Glucocorticoid feedback inhibition of adrenocorticotropin hormone secretagogue release. Relationship to corticosteroid receptor occupancy in various limbic sites. *Neuroendocrinology* 51:328-336.

Sapolsky RM, Stein-Behrens BA, Armanini MP (1991) Long-term adrenalectomy causes loss of dentate gyrus and pyramidal neurons in the adult hippocampus. *Exp Neurol* 114:246-249.

Sapolsky RM (1992) *Stress, the aging brain and the mechanism of neuron death.* Massachusetts: MIT Press.

- Sapolsky RM (1994) The physiological relevance of glucocorticoid endangerment of the hippocampus. *Ann N Y Acad Sci* 746:294-304.
- Sarndahl E, Bokoch GM, Spicher K, Stendahl O, Anderson T (1991) G-proteins and the association of ligand/receptor complexes with the cytoskeleton in human neutrophils. *Biochem Society Trans* 19:1127-1129.
- Sarrieau A, Vial M, Philibert D, Rostene W (1984) In vitro autoradiographic localization of [³H]corticosterone binding sites in rat hippocampus. *Eur J Pharmac* 98:151-152.
- Sawchenko PE, Swanson LW, Steinbusch HW, Verhofstad AA (1983) The distribution and cells of origin of serotonergic inputs to the paraventricular and supraoptic nuclei of the rat. *Brain Res* 277:355-360.
- Sawchenko PE (1987) Adrenalectomy-induced enhancement of CRF and vasopressin immunoreactivity in parvocellular neurosecretory neurons: anatomic, peptide, and steroid specificity. *J Neurosci* 7:1093-1106.
- Sawchenko PE (1988) Effects of catecholamine-depleting medullary knife cuts on corticotropin-releasing factor and vasopressin immunoreactivity in the hypothalamus of normal and steroid-manipulated rats. *Neuroendocrinology* 48:459-470.
- Schafer JA, Troutman SL, Schlatter E (1990) Vasopressin and mineralocorticoid increase apical membrane driving force for K⁺ secretion in rat CCD. *Am J Physiol* 258:F199-F210.
- Schelling JR, DeLuca DJ, Konieczkowski M, Marzec R, Sedor JR, Dubyak, GR, Linas SL (1994) Glucocorticoid uncoupling of angiotensin II-dependent phospholipase C activation in rat vascular smooth muscle cells. *Kidney Int* 46:675-682.
- Scheving LE, Pauly JE (1966) Effect of light on corticosterone levels in plasma of rats. *Am J Physiol* 210:1112-1117.
- Schmidt TJ, Meyer AS (1994) Autoregulation of corticosteroid receptors. How, when, where, and why? *Receptor* 4:229-257.
- Schwartzkroin PA, Prince DA (1980) Effects of TEA on hippocampal neurons. *Brain Res* 185:169-181.

- Schwartzkroin PA, Stafstrom CE (1980) Effects of EGTA on the calcium-activated afterhyperpolarization in hippocampal CA3 pyramidal cells. *Science* 210:1125-1126.
- Schwiebert LA, Beck LA, Stellato C, Bickel CA, Bochner BS, Schleimer RP. (1996) Glucocorticosteroid inhibition of cytokine production: relevance to antiallergic actions. *J Allergy Clin Immunol* 97:143-152.
- Seckl JR, Dickson KL, Fink G (1990) Central 5,7-dihydroxytryptamine lesions decrease hippocampal glucocorticoid and mineralocorticoid receptor messenger ribonucleic acid expression. *J Neuroendocrinol* 2:911-916.
- Seckl JR, Fink G (1991) Use of in situ hybridization to investigate the regulation of hippocampal corticosteroid receptors by monoamines. *J Steroid Biochem Mol Biol* 40:685-688.
- Seckl JR, Fink G (1992) Antidepressants increase glucocorticoid and mineralocorticoid receptor mRNA expression in rat hippocampus in vivo. *Neuroendocrinology* 55:621-626.
- Segal M (1975) Physiological and pharmacological evidence for a serotonergic projection to the hippocampus. *Brain Res* 94:115-131.
- Selye H (1936) Thymus and adrenals in the response of the organism to injuries and intoxications. *Br J Exp Pathol* 17:234-248
- Selye H (1946) The general adaptation syndrome and the diseases of adaptation. *J Clin Endocrinol Metab* 6:117-230.
- Severne Y, Wieland S, Schaffner W, Rusconi S (1988) Metal binding 'finger' structures in the glucocorticoid receptor defined by site-directed mutagenesis. *EMBO J* 7:2503-2508.
- Shahedi M, Laborde K, Bussieres L, Sachs C (1993) Acute and early effects of aldosterone on Na-K-ATPase activity in Madin-Darby canine kidney epithelial cells. *Am J Physiol* 264:F1021-F1026.
- Shen Y, Monsma FJ, Jr., Metcalf MA, Jose PA, Hamblin MW, Sibley DR (1993) Molecular cloning and expression of a 5-hydroxytryptamine₇ serotonin receptor subtype. *J Biol Chem* 268:18200-18204.

- Sheppard KE, Funder JW (1987) Equivalent affinity of aldosterone and corticosterone for type I receptors in kidney and hippocampus: direct binding studies. *J Steroid Biochem* 28:737-742.
- Sheppard KE, Roberts JL, Blum M (1990) Differential regulation of type II corticosteroid receptor messenger ribonucleic acid expression in the rat anterior pituitary and hippocampus. *Endocrinology* 127:431-439.
- Sheppard KE, Roberts JL, Blum M (1991) Adrenocorticotropin-releasing factor down-regulates glucocorticoid receptor expression in mouse corticotrope tumor cells via an adenylate cyclase-dependent mechanism. *Endocrinology* 129:663-670.
- Shinohara H, Asano T, Kato K (1992) Differential localization of G proteins G_i and G_o in the accessory olfactory bulb of the rat. *J Neurosci* 12:1275-1279.
- Siegel RA, Weidenfeld J, Chen M, Feldman S, Melamed E, Chowers I (1983) Hippocampal cell nuclear binding of corticosterone following 5,7-dihydroxytryptamine. *Mol Cell Endocrinol* 31:253-259.
- Slotkin TA, Lau C, McCook EC, Lappi SE, Seidler FJ (1994) Glucocorticoids enhance intracellular signaling via adenylate cyclase at three distinct loci in the fetus: a mechanism for heterologous teratogenic sensitization? *Toxicol Appl Pharmacol* 127:64-75.
- Sloviter RS, Valiquette G, Abrams GM, Ronk E, Sollas A, Paul LA, Neubort S (1989) Selective loss of hippocampal granule cells in the mature rat brain after adrenalectomy. *Science* 243:535-538.
- Sloviter RS, Sollas AL, Dean E, Neubort S (1993) Adrenalectomy-induced granule cell degeneration in the rat hippocampal dentate gyrus: Characterization of an in vivo model of controlled neuronal death. *J Neurosci* 13:324-336.
- Sloviter RS, Sollas AL, Neubort S (1995) Hippocampal dentate granule cell degeneration after adrenalectomy in the rat is not reversed by dexamethasone. *Brain Res* 682:227-230.
- Slusher MA (1964) The effects of chronic hypothalamic lesions on diurnal and stress corticosteroid levels. *Amer J Physiol* 206:1161-1164.

- Smith LI, Mendel DB, Bodwell JE, Munck A (1989) Phosphorylated sites within the functional domains of the approximately 100-kDa steroid-binding subunit of glucocorticoid receptors. *Biochemistry* 28:4490-4498.
- Smith OL, Wong CY, Gelfand RA (1990) Influence of glucocorticoids on skeletal muscle proteolysis in normal and diabetic-adrenalectomized eviscerated rats. *Metabolism* 39:641-646.
- Smythe JW, Rowe WB, Meaney MJ (1994) Neonatal handling alters serotonin (5-HT) turnover and 5-HT₂ receptor binding in selected brain regions: relationship to the handling effect on glucocorticoid receptor expression. *Brain Res Dev Brain Res* 80:183-189.
- Spauschus A, Lentes KU, Wischmeyer E, Dissmann E, Karschin C, Karschin A (1996) A G-protein-activated inwardly rectifying K⁺ channel (GIRK4) from human hippocampus associates with other GIRK channels. *J Neurosci* 16:930-938.
- Spencer RL, Miller AH, Stein M, McEwen BS (1991) Corticosterone regulation of type I and type II adrenal steroid receptors in brain, pituitary, and immune tissue. *Brain Res* 549:236-246.
- Spruston N, Johnston D (1992) Perforated patch-clamp analysis of the passive membrane properties of three classes of hippocampal neurons. *J Neurophysiol* 67:508-529.
- Starkman MN, Gebarski SS, Berent S, Schteingart DE (1992) Hippocampal formation volume, memory dysfunction, and cortisol levels in patients with Cushing's syndrome. *Biol Psych* 32:756-765.
- Stephenson PR (1956) A modification of receptor theory. *Br J Pharmacol* 11:3798-393.
- Stein-Behrens B, Mattson MP, Chang I, Yeh M, Sapolsky R (1994) Stress exacerbates neuron loss and cytoskeletal pathology in the hippocampus. *J Neurosci* 14:5373-5380.
- Sternberger LA, Hardy PH, Cuculis JJ, Meyer HG (1970) The unlabeled antibody enzyme method of immunohistochemistry: preparation and properties of soluble antigen antibody complex (horseradish peroxidase antihorseradish peroxidase) and its use in identification of spirochetes. *J Histochem Cytochem* 18:315-333.

- Sternweis PC, Robinshaw JD (1984) Isolation of two proteins with high affinity for guanine nucleotides from membranes of bovine brain. *J Biol Chem* **259**: 13806-13813.
- Stevens W, Grosser BI, Reed DJ (1971) Corticosterone-binding molecules in rat brain cytosols: regional distribution. *Brain Res* **35**:602-607.
- Stokes JB (1985) Mineralocorticoid effect on K⁺ permeability of the rabbit cortical collecting tubule. *Kid Intern* **28**:640-645.
- Stow JL, Sablic I, Brown D (1991) Heterogenous localization of G protein α -subunits in rat kidney. *Am J Physiol* **261**, F831-F840.
- Strader CD, Dixon RA, Cheung AH, Candelore MR, Blake AD, Sigal IS (1987) Mutations that uncouple the beta-adrenergic receptor from Gs and increase agonist affinity *J Biol Chem* **262**:16439-16443.
- Stumpf WE, Sar M (1979) Steroid hormone target cells in the extrahypothalamic brain stem and cervical spinal cord: neuroendocrine significance. *J Steroid Biochem* **11**:801-807.
- Suemaru S, Darlington DN, Akana SF, Cascio CS, Dallman MF (1995) Ventromedial hypothalamic lesions inhibit corticosteroid feedback regulation of basal ACTH during the trough of the circadian rhythm. *Neuroendocrinology* **61**:453-463.
- Swanson LW, Sawchenko PE, Rivier J, Vale WW (1983) Organization of ovine corticotropin-releasing factor immunoreactive cells and fibers in the rat brain: an immunohistochemical study. *Neuroendocrinology* **36**:165-186.
- Swanson LW, Simmons DM (1989) Differential steroid hormone and neural influences on peptide mRNA levels in CRH cells of the paraventricular nucleus: a hybridization histochemical study in the rat. *J Comp Neurol* **285**:413-435.
- Sylte I, Edvardsen O, Dahl SG (1993) Molecular dynamics of the 5-HT_{1a} receptor and ligands. *Protein Eng* **6**:691-700.
- Szafarczyk A, Alonso G, Ixart G, Malaval F, Nouguiet-Soule J, Assenmacher I (1980) Serotonergic system and circadian rhythms of ACTH and corticosterone in rats. *Am J Physiol* **239**:E482-9.

- Szafarczyk A, Alonso G, Ixart G, Malaval F, Assenmacher I (1985) Diurnal-stimulated and stress-induced ACTH release in rats is mediated by ventral noradrenergic bundle. *Am J Physiol* 249:E219-26.
- Szafarczyk A, Malaval F, Laurent A, Gibaud R, Assenmacher I (1987) Further evidence for a central stimulatory action of catecholamines on adrenocorticotropin release in the rat. *Endocrinology* 121:883-892.
- Tejani-Butt SM, Labow DM (1994) Time course of the effects of adrenalectomy and corticosterone replacement on 5-HT_{1A} receptors and 5-HT uptake sites in the hippocampus and dorsal raphe nucleus of the rat brain: an autoradiographic analysis. *Psychopharmacology (Berl)* 113:481-486.
- Tempel DL, Leibowitz SF (1994) Adrenal steroid receptors: interactions with brain neuropeptide systems in relation to nutrient intake and metabolism. *Journal of Neuroendocrinology* 6:479-501.
- Terashima T, Katada T, Oinuma M, Ui M, Inoue Y (1988) Immunohistochemical analysis of the localization of guanine nucleotide-binding protein in the mouse brain. *Brain Res* 442:305-311.
- Terashima T, Katada T, Ichikawa R, Ui M, Inoue Y (1993) Distribution of guanine nucleotide-binding protein in the brain of the reeler mutant mouse. *Brain Res* 601:136-142.
- Tornello S, Orti E, De Nicola AF, Rainbow TC, McEwen BS (1982) Regulation of glucocorticoid receptors in brain by corticosterone treatment of adrenalectomized rats. *Neuroendocrinology* 35:411-417.
- Torres GE, Holt IL, Andrade R (1994) Antagonists of 5-HT₄ receptor-mediated responses in adult hippocampal neurons. *J Pharmacol Exp Therap* 271:255-261.
- Tsai SY, Carlstedt-Duke J, Weigel NL, Dahlman K, Gustafsson JA, Tsai, MJ, O'Malley BW (1988) Molecular interactions of steroid hormone receptor with its enhancer element: evidence for receptor dimer formation. *Cell* 55:361-369.
- Tsou AP, Kosaka A, Bach C, Zuppan P, Yee C, Tom L, Alvarez R, Ramsey S, Bonhaus DW, Stefanich E, et al. (1994) Cloning and expression of a 5-hydroxytryptamine₇ receptor positively coupled to adenylyl cyclase. *J Neurochem* 63:456-464.

- Uno H, Tarara R, Else JG, Suleman MA, Sapolsky RM (1989) Hippocampal damage associated with prolonged and fatal stress in primates. *J Neurosci* 9:1705-1711.
- Uno H, Eisele S, Sakai A, Shelton S, Baker E, DeJesus O, Holden J (1994) Neurotoxicity of glucocorticoids in the primate brain. *Horm Behav* 28:336-348.
- Van den Berghe N, Nieuwkoop NJ, Vaandrager AB, De Jonge HR (1991) Asymmetrical distribution of G-proteins among the apical and basolateral membranes of rat enterocytes. *Biochem J* 278:565-571.
- Van Eekelen JA, Jiang W, de Kloet ER, Bohn MC (1988) Distribution of the mineralocorticoid and the glucocorticoid receptor mRNAs in the rat hippocampus. *J Neurosci Res* 21:88-94.
- Vanecek J, Pavlik A, Illnerova H (1987) Hypothalamic melatonin receptor sites revealed by autoradiography. *Brain Res* 435:359-362.
- Vedder H, Weiss I, Holsboer F, Reul JM (1993) Glucocorticoid and mineralocorticoid receptors in rat neocortical and hippocampal brain cells in culture: characterization and regulatory studies. *Brain Res* 605:18-24.
- Veldhuis HD, de Kloet ER (1982) Significance of ACTH4-10 in the control of hippocampal corticosterone receptor capacity of hypophysectomized rats. *Neuroendocrinology* 34:374-380.
- Veldhuis HD, Van Koppen C, Van Ittersum M, de Kloet ER (1982) Specificity of the adrenal steroid receptor system in rat hippocampus. *Endocrinology* 110:2044-2051.
- Veldhuis HD, De Korte CC, de Kloet ER (1985) Glucocorticoids facilitate the retention of acquired immobility during forced swimming. *Eur J Pharmacol* 115:211-217.
- Verge D, Daval G, Marcinkiewicz M, Patey A, el Mestikawy S, Gozlan H, Hamon M (1986) Quantitative autoradiography of multiple 5-HT₁ receptor subtypes in the brain of control or 5,7-dihydroxytryptamine-treated rats. *J Neurosci* 6:3474-3482.
- Verrey F (1990) Regulation of gene expression by aldosterone in tight epithelia. *Sem Nephrol* 10:410-420.

- Viollet C, Loudes C, Korden C, Bauman AF (1994) Selective patterns of expression of G protein α subunits during in vitro development of hypothalamic neurons. *J Neurochem* 63: 2231-2239.
- Waeber C, Sebben M, Nieoullon A, Bockaert J, Dumuis A (1994) Regional distribution and ontogeny of 5-HT₄ binding sites in rodent brain. *Neuropharmacology* 33:527-541.
- Walker CD, Sapolsky RM, Meaney MJ, Vale WW, Rivier CL (1986) Increased pituitary sensitivity to glucocorticoid feedback during the stress nonresponsive period in the neonatal rat. *Endocrinology* 119:1816-1821.
- Wang HY, Friedman E (1994) Receptor-mediated activation of G proteins is reduced in postmortem brains from Alzheimer's disease patients. *Neurosci Lett* 173:37-39.
- Warembourg M (1975) Radioautographic study of the rat brain after injection of [1,2-³H]corticosterone. *Brain Res* 89:61-70.
- Warpman U, Alafuzoff I, Nordberg (1993) Coupling of muscarinic receptors to GTP proteins in postmortem brain--alterations in Alzheimer's disease. *Neurosci Lett* 150:39-43.
- Watanabe Y, Gould E, McEwen BS (1992) Stress induces atrophy of apical dendrites of hippocampal CA3 pyramidal neurons. *Brain Res* 588:341-345.
- Watanabe Y, Sakai RR, McEwen BS, Mendelson S (1993) Stress and antidepressant effects on hippocampal and cortical 5-HT_{1A} and 5-HT₂ receptors and transport sites for serotonin. *Brain Res* 615:87-94.
- Watkins PA, Burns DL, Kanaho Y, Liu TY, Hewlett EL, Moss J (1985) ADP-ribosylation of transducin by pertussis toxin. *J Biol Chem* 260:13478-13482.
- Webb ML, Miller-Diener AS, Litwack G (1985) Purification, characterization, and activation of the glucocorticoid-receptor complex from rat kidney cortex. *Biochemistry* 24:1946-1952.
- Weidenfeld J, Siegel RA, Corcos AP, Chen M, Feldman S, Chowers I (1983) Effect of 6-hydroxydopamine on in vitro hippocampal corticosterone binding capacity in the male rat. *Exp Brain Res* 52:121-124.

Weidenfeld J, Bodoff M, Saphier D, Brenner T (1989a) Further studies on the stimulatory action of nicotine on adrenocortical function in the rat. *Neuroendocrinology* 50:132-138.

Weidenfeld J, Rougeot C, Dray F, Feldman S (1989b) Adrenocortical response following acute neurogenic stimuli is mediated by CRF-41. *Neurosci Lett* 107:189-194.

Weidenfeld J, Feldman S (1991a) Effect of 6-hydroxydopamine and 5,7-dihydroxytryptamine on tissue uptake and cell nuclear retention of corticosterone in the rat hypothalamus. *Brain Res* 566:140-145.

Weidenfeld J, Feldman S (1991b) Effect of hypothalamic norepinephrine depletion on median eminence CRF-41 content and serum ACTH in control and adrenalectomized rats. *Brain Res* 542:201-204.

Weiner RI, Ganong WF (1978) Role of brain monoamines and histamine in regulation of anterior pituitary secretion. *Physiol Rev* 58:905-976.

Westlund KN, Wynn PC, Chmielowiec S, Collins TJ, Childs GV (1984) Characterization of a potent biotin-conjugated CRF analog and the response of anterior pituitary corticotropes. *Peptides* 5:627-634.

Westlund KN, Aguilera G, Childs GV (1985) Quantification of morphological changes in pituitary corticotropes produced by in vivo corticotropin-releasing factor stimulation and adrenalectomy. *Endocrinology* 116:439-445.

Westphal HM, Mugele K, Beato M, Gehring U (1984) Immunochemical characterization of wild-type and variant glucocorticoid receptors by monoclonal antibodies. *EMBO Journal* 3:1493-1498.

Wheeler DB, Randall A, Tsien RW (1996) Changes in action potential duration alter reliance of excitatory synaptic transmission on multiple types of Ca²⁺ channels in rat hippocampus. *J Neurosci* 16:2226-2237.

Widmaier EP, Dallman MF (1984) The effects of corticotropin-releasing factor on adrenocorticotropin secretion from perfused pituitaries in vitro: rapid inhibition by glucocorticoids. *Endocrinology* 115:2368-2374.

- Wikstrom AC, Bakke O, Okret S, Bronnegard M, Gustafsson JA (1987) Intracellular localization of the glucocorticoid receptor: evidence for cytoplasmic and nuclear localization. *Endocrinology* 120:1232-1242.
- Wilson MM, Critchlow V (1975) Absence of a circadian rhythm in persisting corticosterone fluctuations following surgical isolation of the medial basal hypothalamus. *Neuroendocrinology* 19:185-192.
- Wilson MM, Greer SE, Greer MA, Roberts L (1980) Hippocampal inhibition of pituitary-adrenocortical function in female rats. *Brain Res* 197:433-441.
- Wolfgang D, Chen I, Wand GS (1994) Effects of restraint stress on components of adenylyl cyclase signal transduction in the rat hippocampus. *Neuropsychopharmacology* 11:187-193.
- Wong RK, Prince DA (1978) Participation of calcium spikes during intrinsic burst firing in hippocampal neurons. *Brain Res* 159:385-390.
- Wong RK, Prince DA, Basbaum AI (1979) Intradendritic recordings from hippocampal neurons. *Proc Natl Acad Sci USA* 76:986-990.
- Wong RK, Prince DA (1981) Afterpotential generation in hippocampal pyramidal cells. *J Neurophysiol* 45:86-97.
- Wong RK, Stewart M (1992) Different firing patterns generated in dendrites and somata of CA1 pyramidal neurones in guinea-pig hippocampus. *J Physiol (Lond)* 457:675-687.
- Woolley CS, Gould E, McEwen BS (1990) Exposure to excess glucocorticoids alters dendritic morphology of adult hippocampal pyramidal neurons. *Brain Res* 531:225-231.
- Worley PF, Barban JM, Cornelis V, Neer EJ, Snyder SH (1986) G_o, a guanine nucleotide-binding protein: immunohistochemical localization in rat brain resembles distribution of second messenger system. *Proc Natl Acad Sci USA* 83:4561-4565.
- Wrange O, Gustafsson JA (1978) Separation of the hormone- and DNA-binding sites of the hepatic glucocorticoid receptor by means of proteolysis. *J Biol Chem* 253:856-865.

Wrange O, Yu ZY (1983) Mineralcorticoid receptor in rat kidney and hippocampus: characterization and quantitation by isoelectric focusing. *Endocrinology* 113:243-250.

Wrange O, Okret S, Radojic M, Carlstedt-Duke J, Gustafsson JA (1984) Characterization of the purified activated glucocorticoid receptor from rat liver cytosol. *J Biol Chem* 259:4534-4541.

Wrange O, Eriksson P, Perlmann T (1989) The purified activated glucocorticoid receptor is a homodimer. *J Biol Chem* 264:5253-5259.

Wright AP, Zilliacus J, McEwan IJ, Dahlman-Wright K, Almlöf T, Gustafsson JA (1993) Structure and function of the glucocorticoid receptor. *J Steroid Biochem Mol Biol* 47:11-19.

Yagaloff KA, Hartig PR (1985) ¹²⁵I-lysergic acid diethylamide binds to a novel serotonergic site on rat choroid plexus epithelial cells. *J Neurosci* 5:3178-3183.

Yamamoto KR (1985) Steroid receptor regulated transcription of specific genes and gene networks. *Annu Rev Genet* 19:209-252.

Yates FE (1967) Physiological control of adrenal cortical hormone secretion. In: *The Adrenal Cortex* (Eisenstein AB ed), pp 133 Boston: Little Brown.

Yau JL, Seckl JR (1992) Central 6-hydroxydopamine lesions decrease mineralocorticoid, but not glucocorticoid receptor gene expression in the rat hippocampus. *Neurosci Lett* 142:159-162.

Yau JL, Dow RC, Fink G, Seckl JR (1992) Medial septal cholinergic lesions increase hippocampal mineralocorticoid and glucocorticoid receptor messenger RNA expression. *Brain Res* 577:155-160.

Yau JL, Olsson T, Morris RG, Meaney MJ, Seckl JR (1995) Glucocorticoids, hippocampal corticosteroid receptor gene expression and antidepressant treatment: relationship with spatial learning in young and aged rats. *Neuroscience* 66:571-581.

Yocca FD, Iben L, Meller E (1992) Lack of apparent receptor reserve at postsynaptic 5-hydroxytryptamine_{1A} receptors negatively coupled to adenylyl cyclase activity in rat hippocampal membranes. *Mol Pharmacol* 41:1066-1072.

Zgombick JM, Beck SG, Mahle CD, Craddock-Royal B, Maayani S (1989) A pertussis toxin-sensitive G-protein couples adenosine A₁ and 5-HT_{1A} receptors to the same effector systems in rat hippocampus: biochemical and electrophysiological studies. *Mol Pharmacol* 35:484-494.

Zifa E, Fillion G (1992) 5-Hydroxytryptamine receptors. *Pharmacol Rev* 44:401-458.

Zimmermann E, Critchlow V (1967) Effects of diurnal variation in plasma corticosterone levels on adrenocortical response to stress. *Proc Soc Exp Biol Med* 125:658-663.

VITA

The author, Dayne Y. Okuhara, was born on January 19, 1963 in Honolulu, Hawaii to Stephen and Marjorie Okuhara. He received his Bachelor of Science degree in Biochemistry at the University of Rochester, Rochester, New York in May, 1990. In August, 1991, Dayne entered the Department of Pharmacology and Experimental Therapeutics of the Graduate School at Loyola University Chicago. Dayne joined the laboratory of Sheryl G. Beck in 1992.

DISSERTATION APPROVAL SHEET

The dissertation submitted by Dayne Y. Okuhara has been read and approved by the following committee:

Sheryl G. Beck, Ph.D., Director
Associate Professor, Department of Pharmacology and Experimental Therapeutics
Loyola University Chicago

Nancy A. Muma, Ph.D.
Associate Professor, Department of Pharmacology and Experimental Therapeutics
Loyola University Chicago

Russell O. Pieper, Ph.D.
Associate Professor, Departments of Medicine and Pharmacology and Experimental Therapeutics
Loyola University Chicago

Mary Druse Manteufel, Ph.D.
Professor, Department on Molecular and Cellular Biochemistry
Loyola University Chicago

Rodrigo Andrade, Ph.D.
Professor, Department of Psychiatry
Wayne State University

The final copies have been examined by the director of the dissertation and the signature which appears below verifies the fact that any necessary changes have been incorporated and that the dissertation is now given final approval by the committee with reference to content and form.

The dissertation is, therefore, accepted in partial fulfillment of the requirement for the degree of Doctor of Philosophy.

11/22/96
Date

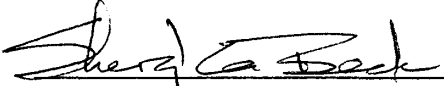
Director's Signature