



1994

The Role of Alternative Splicing in the Regulation of Cathepsin B Expression in Human Tumors

Qiuming Gong
Loyola University Chicago

Follow this and additional works at: https://ecommons.luc.edu/luc_diss

 Part of the [Molecular Biology Commons](#)

Recommended Citation

Gong, Qiuming, "The Role of Alternative Splicing in the Regulation of Cathepsin B Expression in Human Tumors" (1994). *Dissertations*. 3392.

https://ecommons.luc.edu/luc_diss/3392

This Dissertation is brought to you for free and open access by the Theses and Dissertations at Loyola eCommons. It has been accepted for inclusion in Dissertations by an authorized administrator of Loyola eCommons. For more information, please contact ecommons@luc.edu.



This work is licensed under a [Creative Commons Attribution-Noncommercial-No Derivative Works 3.0 License](#).
Copyright © 1994 Qiuming Gong

LIBRARY-LOYOLA UNIVERSITY
MEDICAL CENTER

THE ROLE OF ALTERNATIVE SPLICING IN THE REGULATION
OF CATHEPSIN B EXPRESSION IN HUMAN TUMORS

By

Qiuming Gong

A Dissertation Submitted to the Faculty of the Graduate
School of Loyola University of Chicago in Partial
Fulfillment of the Requirements for the Degree of
Doctor of Philosophy

January

1994

Copyright by Qiuming Gong, 1994

All rights reserved.

ACKNOWLEDGEMENTS

I would like to express sincere thanks to my advisor and mentor, Dr. Allen Frankfater. His guidance, patience and encouragement were essential to the completion of this dissertation.

I also wish to thank my committee members, Drs. Richard M. Schultz, Mark R. Kelley, Sally A. Amero, Gary L. Engelmann and Russell Pieper for their critical readings and discussions of this dissertation.

My appreciation is also extended to all members of the Department of Biochemistry for providing the means to complete this study.

Finally, I wish to acknowledge my parents, my husband and my son, whose sacrifice and understanding were of great help to me.

VITA

The author, Qiuming Gong, was born on August 24, 1957, in Beijing, China.

She entered Beijing Medical University in Beijing, China in March, 1978. In December of 1982, she received her Doctor of Medicine degree. In December of 1985, she received her Master of Science degree in Biochemistry. From December of 1985 to August of 1987, she worked as a research associate in the Department of Biochemistry at Beijing Medical University. In August of 1988, she enrolled in the Graduate School at Loyola University of Chicago in the Department of Molecular and Cellular Biochemistry.

Qiuming has completed her dissertation work under the direction of Dr. Allen Frankfater. She was the recipient of Arthur J. Schmitt Dissertation Fellowship in 1992-1993.

TABLE OF CONTENTS

	Page
ACKNOWLEDGEMENTS	iii
VITA	iv
LIST OF TABLES	viii
LIST OF FIGURES	ix
LIST OF PUBLICATIONS	xi
CHAPTER	
I. INTRODUCTION	1
II. REVIEW OF THE RELATED LITERATURE	6
A. Cellular Proteinases	6
1. Serine Proteinases	6
2. Cysteine Proteinases	7
3. Aspartic Proteinases	8
4. Metallo-Proteinases	9
B. Cathepsin B	9
C. Correlation Between Cathepsin B Expression and Malignant Tumors	15
D. Alternative Pre-mRNA Splicing	22
1. Constitutive Splicing	23
2. Modes of Alternative Splicing	25
3. Factors Affecting Splicing-Site Selection	27
E. Functional Effects of Alternative Splicing of Pre-mRNA	33
1. Protein Localization	34
2. Modulation of Protein Function	36
3. Effects on RNA Stability and Translation Efficiency	39
III. METHODS	42
A. Materials	42
B. Solutions	44

C.	Cell Culture	45
D.	Human Tissues	46
E.	Total RNA Isolation	46
F.	Quantification of Cathepsin B mRNA	47
G.	Northern Blot Analysis	49
H.	RNase Protection Assay	49
I.	Polymerase Chain Reaction (PCR) Amplification of cDNA	53
J.	Sequencing of PCR Fragments	57
K.	Construction of Expression Vectors	58
L.	<i>In Vitro</i> Transcription and Translation	63
M.	Analysis of the Translation Products	64
N.	Folding of an <i>In Vitro</i> Translation Product	65
O.	Measurement of Cathepsin B Activity	66
IV.	RESULTS	69
A.	Quantification of Total Cathepsin B mRNA in Human Normal Tissues and Tumors by Slot Blot	69
B.	Quantification of Variant Cathepsin B mRNAs by Northern Blot and RNase Protection Assay	72
C.	Amplification of the 5'-Ends of Cathepsin B cDNA from Human Normal Tissues and Tumors by PCR	77
D.	Molecular Cloning of Human Cathepsin B cDNA Lacking Exons 2 and 3	81
E.	Detection of Cathepsin B mRNA that is missing exons 2 and 3 by PCR	83
F.	<i>In Vitro</i> Translation of Variant Cathepsin B mRNA	88
G.	Refolding of a Truncated Cathepsin B Produced by the <i>In vitro</i> Translation of mRNA Lacking Exons 2 and 3	96
V.	DISCUSSION	101
A.	Multiple Forms of Cathepsin B Transcripts in Human tissues	101
B.	Levels of Expression of Variant Cathepsin B mRNAs in Human Normal Tissues and Tumors	107
C.	Mechanisms of Alternative Splicing	111
D.	Comparison of Translational Activities of Cathepsin B mRNAs with Variant 5'-UTRs	115

E. Characteristics of Cathepsin B Transcript
Missing Exons 2 and 3 120

VI. SUMMARY 124

BIBLIOGRAPHY 127

LIST OF TABLES

TABLE

1.	Relative levels of cathepsin B mRNA in human tissues and tumor cells	73
2.	Relative proportion of 2.3 Kb and 4.0 Kb cathepsin B mRNAs	76
3.	Relative proportion of cathepsin B mRNA with and without exon 2	79
4.	Exon-intron organization of the human cathepsin B gene	106

LIST OF FIGURES

FIGURE		Page
1.	Organization of the cathepsin B gene and its mRNA transcript	14
2.	Human cathepsin B cDNAs in plasmids phCB79-2 and phCB96-2	43
3.	Scheme for RNase protection assay	50
4.	The riboprobe for RNase protection assay	51
5.	Scheme for PCR amplification of 5'-end of cathepsin B cDNA	55
6.	Scheme for the PCR amplification of cathepsin B cDNA missing exons 2 and 3	56
7.	Scheme for the construction of plasmid phCB79-2-2	60
8.	Scheme for the construction of plasmid phCB79-2-2.3	61
9.	Procedure for folding of translation products <i>in vitro</i>	67
10.	Slot blot hybridization analysis of human normal tissues and cultured melanoma cells for human cathepsin B mRNA	70
11.	Northern blot of cathepsin B mRNA from human normal tissues and cultured melanoma cells	75
12.	RNase protection of variant 5'-ends of human cathepsin B mRNAs	78
13.	Evaluation of the riboprobe used in the RNase protection assay	80
14.	PCR amplification of the 5'-ends of cathepsin B cDNA from human normal tissues and tumors	82

FIGURE	Page
15.	PCR amplification of 5'-end of cathepsin B cDNA missing exons 2 and 3 84
16.	Sequence of the 306 bp PCR product amplified from cathepsin B cDNA in A375M cells 85
17.	Detection cathepsin B mRNA that lacks exons 2 and 3 by PCR 87
18.	Analysis of SP6 directed variant cathepsin B transcripts 90
19.	Rates of <i>in vitro</i> translation of synthetic cathepsin B mRNAs containing variant 5'-UTRs . 92
20.	SDS-PAGE electrophoresis analysis of <i>in vitro</i> translation products from cathepsin B mRNAs with and without exon 2 94
21.	<i>In vitro</i> translation of synthetic cathepsin B mRNAs with variant 5'-ends 97
22.	Refolding of a truncated cathepsin B produced by the <i>in vitro</i> translation of mRNA missing exon 2 and 3 99
23.	Variant cathepsin B transcripts in human tissues 102
24.	Organization of human cathepsin B gene 104

LIST OF PUBLICATIONS

1. Gong, Q., Tung, T.J. and Yang, S.X. (1984). Mouse serum DNA binding protein in non-malignant diseases. *Journal of Beijing Medical University*. 16:26-29.
2. Yu, L.M., Gong, Q. and Tung, T.J. (1986). Comparative study of human and mouse serum DNA binding proteins. *Chinese Biochemical Journal*. 2:27-31.
3. Liu, Y-H., Gong, Q. and Tung, T.J. (1990). Isolation and characterization of high molecular weight DNA binding protein from ascites of mice with Ehrlich ascites carcinoma. *Chinese Biochemical Journal*. 6:264-267.
4. Achkar, C., Gong, Q., Frankfater, A. and Bajkowski, A.S. (1990). Differences in targeting and secretion of cathepsin B and L by BALB/3T3 fibroblasts and moloney murine sarcoma virus-transformed BALB/3T3 fibroblasts. *J. Biol. Chem.* 265:13650-13654.
5. Qian, F., Chan, S.J., Gong, Q., Bajkowski, A.S., Steiner, D.F. and Frankfater, A. (1991). The expression of cathepsin B and other lysosomal proteinases in normal tissues and in tumors. *Biomed. Biochim. Acta.* 50:531-540.
6. Gong, Q. and Tung, T.J. (1991). Purification and characterization of a tumor associated high molecular weight serum DNA binding protein. *Journal of Beijing Medical University*. 23:59-66.
7. Gong, Q., Chan, S.J., Bajkowski, A.S., Steiner, D.F. and Frankfater, A. (1992). Expression of different forms of cathepsin B mRNA transcripts in normal human tissues and tumors. *FASEB J.* 6:A1360. (Abstract).
8. Gong, Q., Chan, S.J., Bajkowski, A.S., Steiner, D.F. and Frankfater, A. (1993). Characterization of the cathepsin B gene and multiple mRNAs in human tissues: evidence for alternative splicing of cathepsin B pre-mRNA. *DNA and Cell Biology*. 12:299-309.
9. Gong, Q. and Frankfater, A. (1993). Alternative splicing of cathepsin B in human tumor produces a truncated protein which can be folded into an active enzyme *in vitro*. *FASEB J.* 7:A1208. (Abstract).

CHAPTER I

INTRODUCTION

Metastasis is believed to involve a series of sequential events which include intravasation, extravasation and invasion, during which tumor cells must penetrate various host tissue barriers. This has led to a hypothesis that metastasis may require the enzymatic degradation of structural components of the extracellular matrix and basement membrane. Consistent with this hypothesis, many studies have shown increased levels of proteolytic enzymes produced by tumor cells. These include metalloproteinases such as collagenase (Fessler et al. 1984), serine proteinases such as tissue type and urokinase type plasminogen activators (Moscatelli et al. 1980; Schmitt et al. 1992), and several lysosomal proteinases including cathepsin B (Sloane et al. 1981; Recklies et al. 1982; Dufek et al. 1984; Qian et al. 1989;), cathepsin L (Gal and Gottesman, 1986; Troen et al. 1988) and cathepsin D (Capony et al. 1987; Maudelonde et al. 1988).

Among these proteinases which may play a role in the metastatic process, cathepsin B has been extensively investigated. Cathepsin B is capable of degrading many of the protein constituents in the extracellular matrix, such as fibronectin, laminin, and type IV collagen and others (Sloane,

1990; Delaisse *et al.* 1991; Buck *et al.* 1992; Cardozo *et al.* 1992). Cathepsin B can also activate a number of latent extracellular proteinases such as procollagenase (Eeckhout and Vaes, 1977) and proplasminogen activator (Kobayashi *et al.* 1991; Schmitt *et al.* 1992). Consequently, were cathepsin B to be secreted by tumor cells, it could cause the degradation of the structural barriers through which tumor cells must migrate during invasion and metastasis (Docherty *et al.* 1983).

Elevated levels of cathepsin B are often associated with cancer (Sloane, 1990). In addition, cathepsin B is not exclusively targeted to lysosomes in tumor cells. It has been reported to be in the nucleus (Pietras and Roberts, 1981) where it could act to modify proteins which regulate DNA replication and gene expression. Cell surface and secreted forms of cathepsin B are also well documented in malignant tumors. In rodents, levels of intracellular and secreted forms of cathepsin B have been correlated with metastatic potential in murine B16 melanoma variants (Sloane *et al.* 1981; Sloane *et al.* 1982; Qian *et al.* 1989), in BDX rat sarcoma variants (Koppel *et al.* 1984) and Lewis lung tumors (Takenaga, 1984), and in humans, in liver (Ohsawa *et al.* 1989), colorectal (Keppler *et al.* 1988a; Maciewicz *et al.* 1989; Sheahan *et al.* 1989), gastric (Watanabe *et al.* 1989) and lung tumors (Kasafirek *et al.* 1990). Higher molecular weight latent forms of cathepsin B have been detected in body fluids of patients with primary liver cancer, ovarian cancer (Mort *et al.* 1983;

Dufek et al. 1984) and breast cancer (Petrova-Skalkova et al. 1987). Forms of cathepsin B associated with the cell surface have been reported for human, rat, and murine tumors (Recklies et al. 1982; Mort et al. 1983; Koppel et al. 1984; Dufek et al. 1984; Petrova-Skalkova et al. 1987; Keren and LeGrue, 1988), and have been correlated with tumor invasiveness and/or metastasis in humans (Weiss et al. 1990) and rodents (Sloane et al. 1986). These and similar findings suggest a direct or indirect role for cathepsin B in facilitating tumor metastasis through its ability to degrade the extracellular matrix and to release tumor cells from solid tumors. However the molecular basis for the increased production of cathepsin B and its abnormal localization to cell membranes, nuclei and secretory vesicles of tumor cells is unknown.

Eukaryotic pre-mRNAs undergo a series of nuclear processing events. Splicing of all intron sequences must occur with a high degree of accuracy in order for functional proteins to be generated. However, flexibility in the selection of a splice site, which forms the basis for the alternative splicing, is not unexpected. Alternative splicing can produce different but related messages. The variant proteins derived from these messages could then be targeted to different cellular and subcellular locations (Kwiatkowski et al. 1986; Johnson et al. 1990; Alt et al. 1980). Alternative splicing can also produce messages which vary in their 5'- or 3'-untranslated regions (UTRs) and consequently affect mRNA

stability and translational efficiency (Kozak, 1991a,b; Brawerman, 1987). Thus, alternative processing of the cathepsin B pre-mRNA may be one of many possible factors which can be advanced for differences in cathepsin B protein levels between normal tissues and tumors, and for the presence of unusual tumor forms of cathepsin B protein which might be directed to the nucleus, the cell surface or the cell exterior.

Cathepsin B mRNA cloned from human kidney is heterogeneous due to alternative processing of the 5'- and 3'-ends of the primary transcript, resulting in mRNAs which contain alternative 5'- and 3'-UTRs (Gong et al. 1993). The variable removal of exon 2 produces transcripts which differ by 88 bases in the lengths of their 5'-UTR. The sequence of exon 2 has features which could decrease the translational efficiency of the transcript. Consequently, were exon 2 more frequently absent from the 5'-UTR of tumor cell cathepsin B mRNAs, it could explain higher levels of cathepsin B in tumors. In this present work we have found that some human tumors contain a third class of transcripts which lack exon 3. As exon 3 contains the coding sequence for the signal peptide required to initially direct cathepsin B to lysosomes, and a portion of the inhibitory propeptide, mRNA lacking exon 3 could be responsible for the presence of active cathepsin B forms at the cell surface and/or within the nuclei of human tumors.

It is my hypothesis that the higher levels of cathepsin B found in tumor cells is due to differences in cathepsin B pre-mRNA processing between normal tissues and tumor cells. Therefore, the specific aims of the present research are: 1) to determine relative abundances of different mRNA forms between normal human tissues and human tumors; 2) to determine translational activities of the various cathepsin B mRNAs which differ in the length of their 5'-UTRs in an *in vitro* translation assay; 3) to clone the transcript lacking exon 3 and to study its translational potential in an *in vitro* assay system; and 4) to determine whether the putative protein products of messages which lack exon 3 possess peptidolytic activity.

CHAPTER II

REVIEW OF THE RELATED LITERATURE

A. Cellular Proteinases

Proteases include two groups: exopeptidase (peptidases) which cleave either amino- or carboxyl-terminal amino acids or dipeptides from proteins, and endopeptidases (proteinases) which cleave peptide bonds in the interior of protein molecules. However, some proteases can have both exo- and endo-peptidase activities.

Proteases can also be subdivided into five classes based on the mechanisms of peptide bond cleavage catalyzed by their active center (Barrett, 1980a): serine proteinases, cysteine proteinases, aspartic proteinases, metalloproteinases, and a fifth category which includes enzymes with different or undetermined catalytic mechanisms. Each of the first four classes will be briefly discussed, and then cathepsin B will be introduced.

1. Serine Proteinases

Serine proteinases include trypsin, chymotrypsin, elastase, coagulation factors, plasmin, cathepsin G, chymases, tryptases, plasminogen activators and others. Sequence

homologies among the serine proteinases suggest that they may have a common evolutionary origin (Hartley, 1970). Serine proteinases all have a serine in their active sites and are active at neutral pH without the need of cofactors. An adjacent histidine residue which functions as a general acid-general base catalyst is essential for the activity of these enzymes (Walsh, 1979). They are synthesized as inactive processors that require limited proteolysis for activation. Serine proteinases, which participate in coagulation, are controlled by a cascade of activating enzymes and a system of protein proteinase inhibitors. Serine proteinases that have been of particular interest in cancer metastasis are plasmin and the pro-urokinase and tissue type plasminogen activators.

2. Cysteine Proteinases

Cysteine proteinases contain a cysteine residue in their active sites. An adjacent histidine residue which functions as a general acid-general base catalyst is also essential for the activity of this class of enzymes (Topham et al. 1990). This subclass of proteinases includes lysosomal enzymes (cathepsin B, H and L) (Barrett, 1980b), the plant proteinase papain, and the cytosolic calcium-activated neutral proteinases, calpains (Barth and Elce, 1981; Dayton and Schollmeyer, 1981). The amino acid sequence of papain and of cathepsin B and H have been found to be significantly homologous (Takio et al. 1983). However, cathepsin H and papain appear more closely related than are papain and

cathepsin B or cathepsin H and cathepsin B. The active sites of cathepsin B and papain are functionally homologous as well as structurally homologous (Bajkowski and Frankfater, 1983a; Bajkowski and Frankfater, 1983b). The lysosomal cysteine proteinases are synthesized as larger inactive precursors which undergo proteolytic maturation. Their mature forms are normally confined to the lysosome and thought to play an important role in intracellular protein degradation. The lysosomal cysteine proteinases exhibit pH optima of about 6.0, and are unstable above pH 7 (Barrett and Kirschke, 1981; Barrett, 1984). However, some lysosomal cysteine proteinases, such as cathepsin B, are secreted into extracellular environment by tumor cells, and appear to retain activity at and above pH 7.0 (Mullins and Rohrllich, 1983).

3. Aspartic Proteinases

Members of the family of aspartic proteinases include pepsin, renin and cathepsin D. All of these enzymes contain aspartate in their active sites, and are synthesized as inactive precursors which are processed either autocatalytically (e.g. pepsin) or by other enzymes (e.g. renin) to remove an N-terminal propeptide. Pepsin, which functions in the acidic milieu of the stomach, is responsible for the initial steps in protein digestion. Cathepsin D is a lysosomal enzyme and plays an important role in intracellular proteolysis in the acidic environment of the lysosome. Renin is thought to have originated from the hypothetical cathepsin

D-like archetype. However, unlike cathepsin D it is stable and active at neutral pH, and is highly specific for the Leu-Leu bond that generates angiotensin I from angiotensinogen (Reid et al. 1978).

4. Metalloproteinases

Metalloproteinases are characterized by the presence of Zn^{2+} in their active sites. Examples of this group include pancreatic carboxypeptidase, thermolysin and collagenases. The metalloproteinases have a neutral to slightly alkaline pH optimum, and their activities can be inhibited by EDTA and thiols. They seem well suited to function extracellularly.

Type IV collagenase, a metalloproteinase, has been found to be secreted by a variety of malignant tumors (Liotta et al. 1982; Fessler et al. 1984). The type IV collagenase degrades the basement membrane type IV collagen molecule at a single site in the helical domain at about one fourth the distance from the N-terminal end (Fessler et al. 1984). Accordingly, the enzyme may be able to decompose the collagen network of basement membrane and thus facilitates penetration by tumor cells.

B. Cathepsin B

Cathepsin B is a cysteine proteinase located in the lysosomes of mammalian cells. Cathepsin B has been isolated from tissues of various mammalian species, including rat liver (Otto, 1971), bovine spleen and liver (Otto, 1971), and human

spleen and liver (Barrett, 1973). Using immunochemical methods, cathepsin B has been located within macrophages (Howie et al. 1985), fibroblasts (Mort et al. 1981), neurons (Howie et al. 1985), myocytes (Bird et al. 1985) and epithelial cells (Howie et al. 1985) of various tissues. Cathepsin B is thought to play an important role in a number of physiological and pathological processes including: degradation of endocytosed proteins (Huisman et al. 1974; Bystryn and Perlstein, 1982) and intracellular proteins (Kar and Pearson, 1977; Shaw and Dean, 1980); processing of secreted proteins (Quinn and Judah, 1978), enzymes (Figarella et al. 1988), hormones (Docherty and Steiner, 1982) and neuromodulatory polypeptides (Docherty and Steiner, 1982); tissue resorption and remodeling (Bayliss and Ali, 1978); inflammation (Daries et al. 1978) and mediation of hormonal response (Pietras et al. 1975). At present, the full spectrum of the biological role of cathepsin B is still not very clear but its broad tissue distribution suggests it has many important functions.

Cathepsin B is both an endopeptidase and a peptidyl dipeptidase (Aronson and Barrett, 1978). Below pH 5, cathepsin B is an exopeptidase (Polgar and Csoma, 1987) catalyzing the successive removal of dipeptides from the carboxyl terminus of proteins (Aronson and Barrett, 1978). Between pH 5 and 7, cathepsin B shows endopeptidase activity (Polgar and Csoma, 1987) with a broad specificity (Barrett and

Kirschke, 1981; Mason, 1989). Synthetic substrates containing the -Arg-Arg- sequence, such as Benzoyl-L-arginine-L-arginine-2-naphthylamide, are extremely sensitive to cathepsin B (McDonald and Ellis, 1975). Fluorogenic and chromogenic synthetic substrates are the most common substrates used in enzyme assays for determination of cathepsin B activity (Barrett, 1973; Bajkowski and Frankfater, 1975).

Mature cathepsin B has a molecular weight of 27,000 - 29,000. It is derived from a larger precursor, procathepsin B, which in its glycosylated state has a molecular weight of about 43,000 (Barrett, 1987; Nishimura et al. 1988). Proteolytic processing of the precursor yields both an active single chain form and a two chain form (Hanewinkel et al. 1987). Procathepsin B can also be activated *in vitro* by limited proteolytic cleavage with pepsin (Achkar et al. 1990; Rowan et al. 1992). Procathepsin B is in turn derived from preprocathepsin B which is synthesized on the rough endoplasmic reticulum. Preprocathepsin B is converted to procathepsin B by cleavage with a signal peptidase which removes the N-terminal signal peptide in the lumen of the rough endoplasmic reticulum.

Procathepsin B is directed to the lysosome where it is converted to biologically active mature forms (McDonald and Ellis, 1975). In fibroblasts, it is known that mannose-6-phosphate receptors segregate newly synthesized lysosomal enzymes from secretory proteins in the *trans* Golgi network.

The lysosomal enzyme-receptor complex is delivered to an intermediate acidified compartment where dissociation of the complex occurs. Receptors are then returned to the Golgi apparatus and cell surface for reuse while lysosomal enzymes in turn are transferred to the lysosome.

There have been many reports of cathepsin B-like activities associated with polypeptides of Mr greater than 26,000-27,000. Steiner and coworkers have shown that ^{125}I -tyrosyl-Arg-ArgCH₂Cl, a cathepsin B substrate analog, covalently labeled three polypeptides of Mr 39,000, 31,500 and 25,000 in rat islet cells (Docherty *et al.* 1983) and in a transplantable rat insulinoma (Docherty *et al.* 1984). The Mr = 31,500 form cross-reacted with anti-rat liver cathepsin B antibodies. Pepsin treatment of the Mr = 39,000 form converted it to a 31,500 protein which was also precipitated with anti-rat liver cathepsin B antibodies, suggesting that the 39,000 and 31,500 polypeptides are related as precursor to product. These workers also found that cathepsin B in rat islets is synthesized initially as a precursor of approximate Mr = 43,000. In the insulinoma the Mr = 39,000 form was found in insulin secretory granules, the Mr = 31,500 form was found in secretory granules and lysosomes, whereas the Mr = 25,000 species was only found in the lysosomal fraction. Consequently, it has been suggested that the larger precursor forms of cathepsin B are sorted into secretory granules, possibly as a consequence of their incomplete targeting to

lysosomes via the mannose-6-phosphate pathway.

Preprocathepsin B cDNAs of human (Fong et al. 1986), rat (Chan et al. 1986) and mouse (Fong et al. 1986) have been cloned and sequenced. Each predicts a primary structure of 339 amino acids. The amino acid sequences of the rat and mouse enzymes are similar, with 90% identity. The human and rat amino sequences are 84% identical in the regions of the mature proteins, and about 50% identical in the preproregions and C-terminal peptide extensions.

The entire human cathepsin B gene has been cloned and its structure elucidated. The 350 nucleotides preceding the transcription start site, large portions of introns 1 and 2 (Gong et al. 1993), and all 12 exons have been sequenced (Fong et al. 1986). There are several Sp1 binding sites in the 5'-flanking region and in intron 1 but no TATA box appropriately positioned with respect to the transcription initiation site.

Cathepsin B cDNA cloned from human tissues is heterogeneous due to differences in processing of the 5' and 3'-ends of the pre-mRNA (Figure 1). Alternative splicing, "exon 2 skipping", produces mRNAs which differ by 88 bases in the lengths of their 5'-untranslated regions. The occasional selection of an alternative intron donor site in exon 11 can result in the loss of an adjacent polyadenylation signal in exon 11 and termination after a downstream signal in exon 12. This produces two kinds of transcripts (2.3Kb and 4.0Kb) which vary in the lengths of their 3'-untranslated regions.

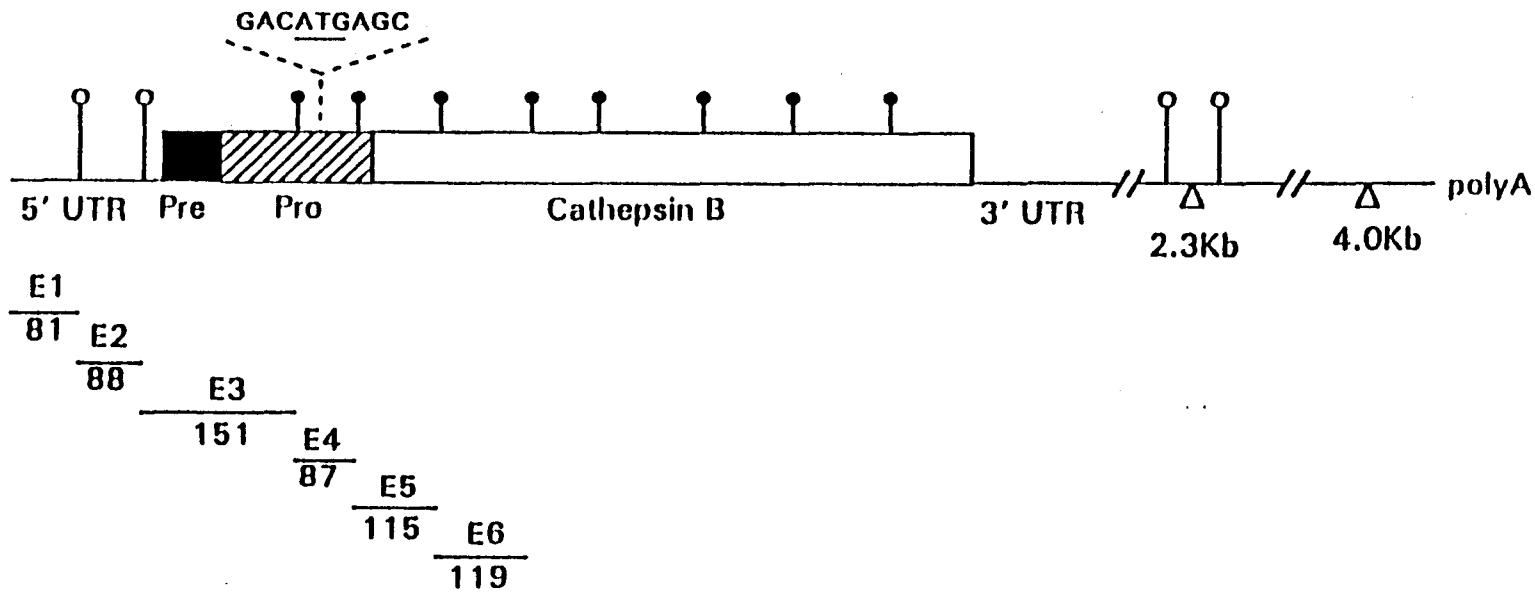

Figure 1. Organization of the cathepsin B gene and its mRNA transcript. Intron positions (¶) and polyadenylation signals (Δ) are identified. The coding regions for the prepeptide, activation propeptide and mature enzyme are indicated by boxes. Also shown are the sizes of the first six exons.

The mouse cathepsin B gene and its 5'-upstream region has also been cloned (Qian et al. 1991b). The gene has 10 exons and 9 introns spanning about 20 kb. Exon 10 contains three potential polyadenylation sites which are alternatively used in transcription of cathepsin B mRNA in B16 melanoma. Like that of human cathepsin B, the 5' upstream region of the mouse cathepsin B gene has several Sp1 binding sites and lacks a TATA box in the immediate vicinity of the transcription start site (Qian et al. 1991b).

C. Correlation Between Cathepsin B Expression and Malignant Tumors

Sufficient evidence has accumulated to implicate proteolytic enzymes as playing an important role in tumor metastasis. Proteinases, either on the cell surface or released by tumor cells, are thought to facilitate tumor cell colonization (Yee and Shiu, 1980; Mainferme et al. 1985). Consequently, many studies have focused on enzymes that are known to degrade connective tissue constituents, such as collagenase (Liotta et al. 1979), neutral proteinase (Edmonds-Alt et al. 1980), plasminogen activator (Laug et al. 1983), glycosidase (Kramer et al. 1986) and cathepsin B (Recklies et al. 1982; Qian et al. 1989). There may also exist a proteolytic cascade in which one or more proteinases act in concert and a newly activated protein in turn may activate others (Kramer et al. 1986; Kobayashi et al. 1992).

In the case of cathepsin B, increased enzyme activity has

been found in a large number of metastatic tumors. Elevated cathepsin B activity has been reported in humans for liver (Dufek et al. 1985), colorectal (Dufek et al. 1984; Keppler et al. 1988a; Maciewicz et al. 1989; Sheahan et al. 1989), gastric (Watanabe et al. 1989), breast (Poole et al. 1978; Recklies et al. 1980; Dengler et al. 1991; Lah et al. 1992), lung (Kasafirek et al. 1990) and cervical cancers (Pietras and Roberts, 1981). In addition, positive correlations have been observed between intracellular levels of cathepsin B and the metastatic phenotype in the murine B16 melanoma variants (Sloane et al. 1981; Sloane et al. 1982), in cultured three Lewis lung clones (Takenaga, 1984) and in cultured BDX rat sarcoma variants (Koppel et al. 1984). The presence of the elevated cathepsin B activity in tumor cells suggests a direct or indirect role for this enzyme in the degradation of the extracellular matrix and in the release of tumor cells from solid tumors. Cathepsin B can degrade fibronectin, laminin and type IV collagen (Sloane, 1990), and can activate latent collagenase (Eeckhout and Vaes, 1977) and pro-urokinase type plasminogen activator (Kobayashi et al. 1991).

Further evidence in support of a role for cathepsin B in tumor invasion is the observation of increased cathepsin B activity in plasma membrane of tumor cells, at the margins of actively growing tumors in direct contact with the extracellular matrix, and the observation of the release of cathepsin B from tumor cells. Cathepsin B activity has been

found in the plasma membrane fraction from anaplastic sarcoma in BDX rat (Koppel et al. 1984), from murine fibrosarcomas (Keren and LeGrue, 1988), from mouse B16 melanoma variants in proportion to the metastatic potential of the variants (Sloane et al. 1986), and from a human pancreatic adenocarcinoma (Zucker et al. 1985). Cathepsin B activity is localized at the invasion front of a rabbit V2 carcinoma (Graf et al. 1981). The secreted enzymes are very similar to lysosomal cathepsin B in terms of their reactivity to synthetic substrates. It was shown that cultured explants of malignant human breast tumors released eleven times more cathepsin B activity than normal breast tissue or nonmalignant tumors (Poole et al. 1978; Recklies et al. 1980). Other reports indicated elevation of cathepsin B activity in the serum of women with genital tract cancer especially in those patients with invasive carcinomas (Pietras et al. 1979; Pietras and Roberts, 1981), in malignant ascites fluid from patients with primary liver and ovarian cancer (Mort et al. 1983; Dufek et al. 1984), in pleural effusions from patients with breast cancer (Petrova-Skalkova et al. 1987), and in conditioned media from human and murine tumors (Recklies et al. 1982; Mort et al. 1983; Qian et al. 1989).

The secreted cathepsin B-like enzyme activities are different from lysosomal cathepsin B in that they have higher molecular weights. Two extracellular high molecular weight forms of human cathepsin B with Mr 40,000 have been observed,

one is latent, the other active. In ascitic fluid and culture medium of ascites cells from cancer patients, a latent form of cathepsin B was discovered which could be activated by pepsin pretreatment (Mort et al. 1981). In addition, malignant human breast tumors in organ culture release a high molecular weight form of cathepsin B that was detected by its ability to hydrolyze synthetic substrates for which lysosomal cathepsin B has high specificity (Mort et al. 1980). The advantages that tumor cells gain by secreting latent and high molecular weight forms of lysosomal proteinase may be related to the instability of low molecular weight lysosomal form above pH 7, resulting in rapid denaturation and inactivation in serum. In contrast, high molecular weight latent and active forms of cathepsin B are more stable under these same conditions (Mort and Rechlies, 1986). In addition, secretion of a latent enzyme, which is then activated some distance from tumor cells, may protect the enzyme from inactivation by endogenous inhibitor while undergoing transport to its site of action. Thus, the active, high molecular weight secreted form of cathepsin B is not inhibitable by plasma proteinase inhibitor, α 2-macroglobulin, whereas the lysosomal form is inhibitable (Mort and Rechlies, 1986). Schultz and his associates found that leupeptin, an inhibitor of cathepsin B did not prevent the invasion of B16-F10 melanoma cells across basement membrane *in vitro* (Persky et al. 1986) or lung colonization *in vivo* (Ostrowski et al. 1986). In contrast, Belleli et al

(1990) recently found that papain-immunized mice possessed serum antibodies which cross-react with cathepsin B like endopeptidase isolated from B16 melanoma cells. The growth rate, invasion and metastasis of both B16 melanoma and the Lewis lung carcinoma were inhibited in mice immunized with papain. It may be that the secreted and/or membrane associated forms of cathepsin B, which might be insensitive to inhibition by leupeptin but can react with anti-papain antibodies, play a role in the metastasis of B16 melanoma cells.

The molecular basis for increased cellular and secreted levels and altered cellular distribution of cathepsin B in tumor cells is not well understood. Possible factors may include differences in transcription, post-transcriptional processing, translation, and post-translational processing of cathepsin B. Comparisons of mRNA levels for five lysosomal proteinases, cathepsin B, D, H, L, and S in B16 melanoma cells, in rat W-256 carcinoma cells, and in normal rodent tissues revealed that only the mRNA for cathepsin B is elevated in the malignant tumors (Qian *et al.* 1989; Qian *et al.* 1990). A correlation between the metastatic potentials of several B16 melanoma variants and cathepsin B mRNA levels has been observed. No evidence was found for gene amplification or gross chromosome rearrangement, or for the presence of more than one gene for cathepsin B in melanoma cells. These findings together with recent results of nuclear run off

assays (F. Qian, unpublished results) suggest that in these cells cathepsin B expression is regulated, at least in part, at the level of RNA transcription.

In addition to the normal 2.2 Kb transcript, two larger transcripts (4.0 and 5.0 Kb) were found in B16 melanomas. These larger transcripts were not seen in normal mouse tissues (Qian et al. 1989). A comparison of the cDNAs derived from the larger transcripts with the cathepsin B gene and cDNA derived from normal message revealed that all three transcripts from mouse melanoma cells encoded for the same form of cathepsin B and differed only in the lengths of their 3'-untranslated regions. The differences in the 3'-UTRs was due to the utilization of alternative polyadenylation signals during the processing of the 3'-end of cathepsin B pre-mRNA, the larger transcripts resulting from the occasional use of downstream polyadenylation signals in melanoma cells (Qian et al. 1991b; Qian et al. 1991c). Thus, the secretion and altered distribution of cathepsin B in murine melanoma cells is not due to alteration in the gene or in the pre-mRNA processing, but more likely due to aberrant proenzyme processing and sorting.

Mannose-6-phosphate receptors and mannose-6-phosphate-containing sugar side chains are required for correct delivery of enzymes to lysosomes (Kornfeld, 1987). Alterations in N-linked oligosaccharides have been found in procathepsin D secreted by MCF7 mammary cancer cells (Capony et al. 1989).

The secretion of procathepsin L by Kirsten sarcoma virus-transformed fibroblasts (KNIH cell) is reported to be due to poor binding of cathepsin L to mannose-6-phosphate receptor, together with saturation of the mannose-6-phosphate receptor resulting from cathepsin L overexpression (Dong et al. 1989). Moloney murine sarcoma virus-transformed fibroblasts (MMSV cell) express 3-4 fold higher levels of cathepsins B, D, and L, but not H and S (Qian et al. 1991a). In addition, MMSV cells appear to have a general defect in lysosomal enzyme sorting which causes the increased secretion of latent cathepsin B, cathepsin L and an active β -glucuronidase (Achkar et al. 1990). This enhanced lysosomal enzyme secretion was correlated with an absence of cell surface mannose-6-phosphate receptor activity (Achkar et al. 1990) and an alkalinization of vacuolar compartments, which should prevent lysosomal enzyme-mannose-6-phosphate receptor uncoupling (Pracht et al. 1991). Agents which acidified MMSV cells strongly inhibited cathepsin B secretion and restored cellular levels to amounts seen in normal fibroblasts. These results agree with the finding that estrogen increases the secretion of cathepsins D, L, and B by human mammary carcinoma MCF-7 cells by down-regulating mannose-6-phosphate receptor expression (Mathieu et al. 1991).

In contrast to the above results in mouse, cathepsin B expression in human tissues may be regulated at the level of mRNA processing. Multiple forms of the cathepsin B mRNAs

which differ in their 3' and 5'-untranslated regions were also found in human tissues. These different forms of mRNA arise from alternative splicing of the 5' and 3'-untranslated regions (Figure 1). Examples of messages with alternative 5'-untranslated regions have been described (Young *et al.* 1981; Lowe *et al.* 1987; Shen *et al.* 1988; Nonaka *et al.* 1989; Horiuchi *et al.* 1990; Waterhouse *et al.* 1990). Many reports have indicated that changes in the 5'-noncoding sequence of a message can affect the translational efficiency of the message (Rao *et al.* 1988; Horiuchi *et al.* 1990; Waterhouse *et al.* 1990; Grens and Scheffler, 1990). Alternative utilization of multiple polyadenylation signals in 3'-end processing of pre-mRNA has also been described (Setzer *et al.* 1980; Tosi *et al.* 1981; Aho *et al.* 1983; Sanke *et al.* 1988). Modifications at the 3'-ends of messages have been shown to affect the translational capacity (Grens and Scheffler, 1990) and rates of mRNA turnover (Brawerman, 1987; Ross, 1988) in some cases. The alternative splicing of pre-mRNA and its functional effects are reviewed in next section.

D. Alternative Pre-mRNA Splicing

Eukaryotic pre-messenger RNAs undergo a series of nuclear processing events. In addition to 5' capping with 7-methyl guanosine (Salditt-Georgieff *et al.* 1980), and the addition of a poly A tail to the 3' end of the nascent transcripts (Birnstiel *et al.* 1985), introns must be precisely excised and

exons correctly ligated to avoid disrupting the open reading frame. Not unexpectedly, the pre-mRNAs can sometimes be spliced in more than one way. In recent years, alternative pre-mRNA splicing has emerged as a powerful post-transcriptional mechanism for regulating gene expression. By utilizing different splice sites within the same precursor RNA, multiple transcripts and corresponding protein products can be generated from a single gene. In this section, alternative splicing and its function will be reviewed after briefly introducing constitutive splicing.

1. Constitutive Splicing

The splicing reaction has been extensively studied in cell-free systems that used exogenous pre-mRNA substrates (Grobowski *et al.* 1984; Krainer *et al.* 1984; Ruskin *et al.* 1984 Lambowitz, 1989). Splicing is a multistep process involving two successive transesterification reactions (Sharp, 1987). Initially, cleavage occurs at the 5' donor splice site, and the 5' end of the intron is joined to an adenosine residue located within the intron (branch-point), giving rise to a lariat form of the intron. The second transesterification reaction between the 5' splice donor and 3' splice acceptor sites results in ligation of the exons and release of the lariat intron. Comparison of sequences of the corresponding genomic DNA with that of cDNA revealed that moderately conserved and short consensus sequences exist at intron-exon boundaries (Mount, 1982). The 5' donor splice

site consensus is AG/GUP_nGU (where the intron-exon boundary is denoted by the backslash), and the 3' acceptor splice site consensus sequence is P_nAG/G. Of these bases, the most highly conserved are the first two and last two bases of the intron.

Although important, these consensus sequences are not sufficient to define efficient splice sites because similar sequences are found in positions other than actual splice sites. Some of these cryptic sites can be activated when the normal splice sites are mutated (Ruskin *et al.* 1985; Aebi *et al.* 1987). Several observations had led to a suggestion that small ribonucleoprotein particles (snRNPs) somehow assisted in the splicing reaction. First, the short consensus sequence at the 5' end of introns was found to be complementary to a site near the 5' end of the small nuclear RNA (snRNA), called U1 (Lerner *et al.* 1980). Second, snRNAs were found in nuclear extracts as part of large particles containing pre-mRNA (Steitz *et al.* 1988). Subsequently, U1, U2, U4, U5 and U6 have been purified, sequenced and shown to be necessary for splicing (Guthrie, 1991; Ruby and Abelson, 1991). All of these snRNAs are associated in the nucleus with six to ten proteins to form snRNPs. These snRNPs assemble with pre-mRNA and additional proteins to form a large particle, called a spliceosome.

The total population of pre-mRNA in the cell nucleus, known as heterogeneous nuclear RNA (hnRNA), is found in association with a discrete set of proteins, forming repeating

structures termed hnRNP particles. These are visualized as a linear array of globular monparticles along each pre-mRNA molecule (Dreyfuss, 1986). Cleavage of the linker RNA by brief RNase treatment releases single particles that sediment at 30-40S. These particles contain a segment of hnRNA about 700 nucleotides long and core hnRNP proteins, A1, A2, B1, B2, C1, and C2, in a well-defined stoichiometry (Conway et al. 1988). Because of their abundance and association with hnRNA, hnRNP proteins are thought to be involved in the packing and posttranscriptional processing of all pre-mRNA. *In vitro* studies under splicing conditions showed sequence-specific binding of hnRNP protein A1 to the 3' splicing site (Swanson and Dreyfuss, 1988). In nuclear extracts, UV-induced cross-linking of hnRNP proteins A1 and C to pre-mRNA requires the presence of U1 and U2 snRNPs, suggesting that specific interactions take place between hnRNP and snRNP particles (Mayrand and Pederson, 1990). Prevention of *in vitro* splicing reaction by the antibodies against hnRNP proteins indicated a requirement of hnRNP proteins during splicing (Choi et al. 1986; Sierakowska et al. 1986).

The interactions of the *cis*-acting elements in pre-mRNA with the *trans*-acting protein and snRNA factors are necessary for constitutive splicing. These interactions are thought to be altered and/or regulated to allow for alternative splicing.

2. Modes of Alternative Splicing

Smith et al (1989) have devised a scheme for classifying

alternative splicing based upon a wide variety of possible regulated events which can give rise to different mRNA transcripts from the same initial gene.

Retained Intron Introns can either be spliced out or retained in the mature RNA. The retained intron can result in a premature termination, an altered amino acid segment due to frameshift, or the insertion of a peptide if the open reading frame is maintained. Premature termination or frameshift may cause functionally different products to be made or may produce no functional product. Such examples are found in the genes for fibronectin (Schwarzbauer *et al.* 1987) and the A-chain of platelet derived growth factor (Tong *et al.* 1987).

Alternative 5' Donor Sites and 3' Acceptor Sites Alternative utilization of 5' donor and/or 3' acceptor sites can excise introns of different lengths, resulting in retained exons of different sizes. Again, this can give rise to the insertion or deletion of a small peptide if the reading frame is maintained, or frameshifting and premature termination.

Alternative Promoters and Polyadenylation Sites In some cases, a gene may contain more than one promoter or more than one poly A attachment site. The mRNAs which differ in their 5' and 3' ends can result from differential utilization of more than one promoter or more than one polyadenylation signal. This can lead to variations in the amino acid sequence of the amino- or carboxyl-terminals of a protein, or to variations in the 5' and 3' untranslated regions of the

message. Utilization of alternative promoters dictates the splicing pattern of myosin light chain gene (Periasamy et al. 1984), while an example of alternative 3' end exons resulting from the selection of different polyadenylation sites is found in α -tropomyosin transcripts (Helfman et al. 1986).

Mutually Exclusive Exons Internal exons are sometimes used in a mutually exclusive manner. One member of the pair is always spliced into the mRNA, but never both. Thus, the two exons are never spliced together, nor are they both skipped. Examples of such splicing are found in genes for α and β tropomyosins (Helfman et al. 1986; Goodwin et al. 1991). Isoforms TM-5a and TM-5b of α -tropomyosin are due to alternative inclusion of exon 6a and 6b respectively. The differences in the amino-acid sequence encoded by these alternate exons affects the actin-binding pattern of the tropomyosin.

Cassette Exons Some cassette exons can be included or excluded (skipped). This can lead to insertion of small peptide segment, premature termination, or a shift of reading frame. An example of such cassette exons is found in the troponin-T gene (Breitbart and Nadal-Ginard, 1987). The presence of five cassette exons at 5' end of the gene give rise to hypervariability within the N-terminal region of troponin-T.

3. Factors Affecting Splicing-Site Selection

Splicing of all intron-containing pre-mRNAs must occur

precisely in order to generate functional proteins. Authentic splicing sites, which exhibit sequence conservation, are accurately selected and matched by poorly understood mechanisms. On the other hand, flexibility in the selection of splice sites forms the basis for alternative splicing, an important mechanism for posttranscriptional control of gene expression. Thus, a large number of genes can express several related, but structurally and functionally distinct protein isoforms. The corresponding mRNAs arise by selection of alternative splice sites, a process that is often subject to tissue-specific or developmental control. The molecular mechanisms responsible for the specificity of constitutive and alternative splice-site selection are not well understood. Some *cis*- and *trans*-acting factors have been reported to be involved in splice-site selection, some essential for splicing, others affecting the efficiency with which a splice site is utilized. RNA secondary structure is also shown to affect splice-site selection.

Cis-Acting Factors The 5' splice site acting as a *cis*-splicing element is highly conserved (Ohshima and Gotoh, 1987; Shapiro and Senapathy, 1987). Mutations within the 5' GU dinucleotide at the intron boundary inhibit *in vitro* splicing (Aebi et al. 1987; Treiman et al. 1983), and often cause activation of nearby cryptic splice sites *in vivo*. Variations of the 5' splice-site consensus outside of the GU do not absolutely impair splicing, but can affect the efficiency with

which the splice-site is used. Usually, mutation of 5' splice sites towards the consensus improves their competitive efficiency (Aebi et al. 1986; Eperon et al. 1986; Zhuang et al. 1987; Mayeda and Ohshima, 1988).

The 3' splice-site consensus is another *cis*-acting factor which can affect the splicing. The AG dinucleotide at the intron-exon boundary is absolutely conserved (Mount, 1982; Padgett et al. 1986; Ohshima and Gotoh, 1987). The point mutation or deletion of the AG dinucleotide always inhibits splicing to the mutated splice site (Aebi et al. 1986; Lamond et al. 1987). However, in some cases, this mutation could result in utilization of the next downstream AG dinucleotide as the 3' splice site.

In addition to 5' and 3' splice site consensus, branch-point sequence and location have also been shown to affect the splicing. The branch-point consensus is commonly found 20-40 nt upstream of the 3' splice site (Smith and Nadal-Ginard, 1989; Helfman and Ricci, 1989). Deletion of the sequence between the branch-point and 3' splice site could result in alternative splice-site selection (Helfman et al. 1990; Guo et al. 1991). The most highly conserved position in the consensus is the A at the site of branch formation. Point mutations of the branch-point sequence often have no effect upon splicing due to the activation of a nearby cryptic branch point (Padgett et al. 1985; Reed and Maniatis, 1985; Ruskin et al. 1985). It has been found that some alternatively spliced

introns contained multiple branch points associated with a single acceptor site (Gattoni et al. 1988; Noble et al. 1988; Helfman and Ricci, 1989) demonstrated that the utilization of different branch points plays a crucial role in the alternative splicing of the SV40 pre-mRNA. The large-T and small-t mRNAs result from the use of two alternative 5' splice sites joined to a single shared 3' splice site.

Trans-Acting Factors The observation that identical primary transcripts are processed along alternative splicing pathways, according to cell type or stage of development, clearly demonstrates differences in the trans-splicing environments of these cells (Medford et al. 1984; Bretibart et al. 1985; Leff et al. 1987; Breitbart and Nadal-Ginard, 1987; Tsurushita et al. 1988). Such variability in the splicing environments is likely determined by specific splicing factors. Some RNA and protein factors which are required for constitutive splicing are present in variant forms. These variant forms may increase the possibility for regulation of alternative splice-site selection.

snRNPs, U1, U2, U5, and U4/U6, have all been shown to be essential for splicing by a combination of antibody and RNase H mediated degradation experiments (Krainer et al. 1984; Kramer et al. 1984; Black et al. 1985; Chabot et al. 1985; Black and Steitz, 1986; Berget and Robberson, 1986). Some snRNAs showed heterogeneity. For example, about 15% of the total human U1 RNAs may be composed of variant sequences

(Lund, 1988). In addition, in mouse, multiple U1 RNAs have been detected and appear to be developmentally regulated (Kato and Harada, 1985; Lund et al. 1985). Likewise, U4 RNAs are regulated in a developmental and tissue-specific manner in chicken and *Xenopus* (Lund and Dahlberg, 1987; Krof et al. 1988). Sequence heterogeneity of U2 RNA has not been detected but it is thought that posttranscriptional base modification may be developmentally regulated and lead to heterogeneous U2 snRNPs (Lund and Dahlberg, 1987). Thus, variant forms of snRNPs which are developmentally regulated and/or tissue specific may facilitate differential splice-site selection.

In addition to the above snRNPs, several other protein factors have to be shown to affect alternative splicing. One cellular factor isolated from mammalian cells termed ASF (alternative splicing factor) or SF2 has been found to affect the choice of alternative 5'-splice sites (Ge and Manley, 1990; Krainer et al. 1990a). *In vitro* splicing studies with the early region of simian virus (SV40) involving the large T- and small t-splice choices, and a model pre-mRNA substrate derived from the human β -globin gene, demonstrated that high concentrations of ASF/SF2 promote the use of proximal 5'-splice sites, whereas low concentrations favor the use of distal 5'-splice sites. Recently, hnRNP A1 has been reported to specifically counteract the effect of ASF/SF2 on the splice-site selection (Mayeda and Krainer, 1992). The hnRNP A1 is not a general inhibitor of ASF/SF2, since both hnRNP A1

and ASF/SF2 are essential splicing factors (Krainer et al. 1990b). However, when two alternative 5' splice sites are available for splicing, the ratio of hnRNP A1 to ASF/SF2 precisely determines which splice site is used *in vitro*. High concentrations of ASF/SF2 activates proximal 5' splice sites, whereas high concentrations of hnRNP A1 favor distal 5' splice sites with several model and natural alternatively spliced pre-mRNAs. The regulation of these antagonistic activities may play an important role in the tissue-specific and developmental control of gene expression by alternative splicing of pre-mRNA.

RNA Secondary Structure Several authors have suggested that one way in which sequences other than the primary consensus sequences might influence splicing patterns is to alter the secondary structure within the precursor RNA and thereby alter the utilization of a splice site (Solnick, 1985; Eperon et al. 1988; d'Orval et al. 1991; Libri et al. 1991; Estes et al. 1992). The potential of secondary structure to affect splice-site selection was first demonstrated with artificially constructed transcripts. When an exon was put into the loop of a hairpin by inserting long inverted repeats into the adjoining introns, *in vitro* splicing apparatus generated a novel, "jump"-spliced RNA that had the flanking exons joined directly together, leaving out the exon in the loop. To a lesser extent, the hairpin caused the same alternative splice *in vivo*, in transfected Hela cells

(Solnick, 1985). The extent by which the exon within a stem-loop structure was "skipped" was inversely proportional to the stability of the stem (Solnick and Lee, 1987; Eperon et al. 1988). Recently, secondary structure in the chicken β -tropomyosin pre-mRNA has been shown to play a role in the regulation of the alternative splicing of this message (d'Orval et al. 1991; Libri et al. 1991; Guo et al. 1991). The chicken β -tropomyosin pre-mRNA is spliced in a tissue-specific manner to yield mRNAs coding for different isoforms of this protein. Exons 6A and 6B are spliced in a mutually exclusive manner; exon 6B was included in skeletal muscle, whereas exon 6A was preferred in all other tissues. The distal portion of the intron upstream of exon 6B was shown to form stable double-stranded regions with part of the intron downstream of exon 6B. This structure repressed splicing of exon 6B to 7 in a Hela cell extract. Derepression of splicing occurred on disruption of this structure and repression followed when the structure was reformed. Thus, cellular factors which either stabilize or melt secondary structure may regulate alternative splicing.

E. Functional Effects of Alternative Splicing of Pre-mRNA

The functional effects of alternative splicing of pre-mRNA is a subject of considerable interest. Strong correlations have been made between alternative splicing and biological function. These cases highlight the importance of

alternative splicing as a posttranscriptional regulatory event which can quantitatively and qualitatively control gene expression. Alternative splicing in most cases gives rise to protein isoforms sharing some identical regions, and varying in some specific domains, thus allowing for the modulation of protein function, such as regulation of protein localization, modification of protein activity, and production of novel protein activities. Alternative splicing is also used to quantitatively regulate gene expression, by giving rise to prematurely truncated open reading frames, or by regulating mRNA stability or translational efficiency via variability in the untranslated regions. As a mechanism to regulate gene expression and generate protein diversity, alternative splicing has advantages over gene rearrangement and extensive multigene families. It allows for switches in protein isoforms without permanent changes in the cell genetic content, and without changes in transcriptional activity. Functional effects of alternative splicing are reviewed below.

1. Protein Localization

Regulated alternative RNA processing is often used to specify the localization of proteins. There are a number of cases of proteins which are either present within the cell or are secreted. For example, the actin filament-severing protein gelsolin exists as both a plasma protein and a cytoplasmic protein. The two mature proteins are identical except for an additional 25 amino acid residues at the its

amino terminus of the plasma isoform. The two isoforms are expressed from the same gene by the differential use of alternative promoters and alternative splicing of 5' exons that code for the extra 25 amino acids of the mature plasma protein and a 27 amino acid cleavable signal peptide that directs its initial translocation from the cytosol into the rough endoplasmic reticulum (Kwiatkowski et al. 1986). No functional differences have been detected between the intracellular and extracellular forms of gelsolin.

Avian epidermal growth factor receptor is another example of a protein that utilizes alternative splicing to generate membrane-bound and secreted forms (Flickinger et al. 1992). Epidermal growth factor receptor is a 170 KDa transmembrane glycoprotein which is encoded by 12 Kb or 8.6 Kb transcripts. Recently, a small transcript (2.6 Kb) was isolated. This transcript encodes a soluble, secreted and truncated receptor molecule that can act as an antagonist to inhibit full-length receptor function. Sequence analysis of corresponding cDNA and genomic DNA revealed that the 2.6 Kb epidermal growth factor receptor transcript is produced by alternative splicing. The 3' end of this transcript diverged from the sequence of the extracellular ligand-binding domain of the full length receptor are a result of the utilization of an alternative polyadenylation signal between exons 12 and 13 of the full length receptor transcript.

The gene for immunoglobulin μ (Ig μ) heavy chain also

gives rise to membrane-bound and secreted forms by alternative splicing. The Ig μ heavy chain is present in early B lymphocytes as a membrane-bound form. Upon B-cell maturation, following antigen stimulation, levels of the membrane-bound form progressively decrease while the production of a secreted pentameric form increases. This switch is achieved by the alternative use of 3' end exons; the early B-lymphocyte form codes for the hydrophobic membrane-binding segment (Alt et al. 1980; Early et al. 1980; Rogers et al. 1980). These examples show that alternative splicing could regulate the distributions of a protein between subcellular compartments. The targeting of protein to different locations involves the use of leader sequences that are removed from the mature protein during or after transportation, or by the use of membrane targeting sequences which are modified by attachment of membrane anchoring substituents. The distribution of proteins to more than one cell compartment could thus be regulated by alternative splicing of such targeting sequences.

2. Modulation of Protein Function

Functionally distinct protein isoforms are often produced by alternative splicing. Generation of the protein isoforms with differing functions due to alternative splicing has been found for some transcription factors (Lillycrop and Latchman, 1992; Morris et al. 1992), receptors (Mosley et al. 1989; Baumbach et al. 1989; Takaki et al. 1990; Johnson et al. 1991; Flickinger et al. 1992), ion channels (Schwarz et al. 1988;

Timpe *et al.* 1988) and enzymes (Imamura and Tanaka, 1982; Noguchi *et al.* 1986; Liang *et al.* 1991).

The RNA encoding the octamer-binding transcriptional factor Oct-2 is alternatively spliced to yield multiple mRNAs encoding different isoforms of the protein. Isoforms Oct 2.4 and 2.5 differ from the other forms, Oct 2.1, 2.2, and 2.3, at their carboxyl termini. When introduced into cells lacking endogenous Oct-2, various Oct-2 isoforms have different effects on octamer-containing promoters (Lillycrop and Latchman, 1992). The Oct 2.1, 2.2, and 2.3 forms stimulate all octamer-containing promoters. However, the Oct 2.4 and 2.5 forms can repress some promoters and stimulate others, depending on the sequence of the octamer motif and its context within the promoter. Thus alternative splicing can generate different isoforms of the Oct-2 proteins with different effects on gene expression. Alternative splicing has also been observed to affect the transcription factor Pit-1 in a similar manner (Morris *et al.* 1992).

Changes in receptor functions can be correlated with alternative splicing of epidermal growth factor receptor (Flickinger *et al.* 1992), fibroblast growth factor receptor (Johnson *et al.* 1990; Johnson *et al.* 1991), interleukin receptors (Mosley *et al.* 1989; Takaki *et al.* 1990) and growth hormone receptor pre-mRNAs (Baumbach *et al.* 1989). In these cases, alternatively spliced mRNAs encode the soluble, secreted or truncated receptors which often lack transmembrane

domains or cytoplasmic domains, but contain extracellular ligand binding domains and retain ligand binding abilities. One can speculate that the secreted receptors can act as reservoirs to regulate levels of extracellular ligands, or inhibitors to block ligand-mediated responses by preventing interaction of the ligands with membrane-bound forms of receptors. For instance, alternatively processed mRNA from the epidermal growth factor receptor gene encodes a soluble truncated form of the receptor that can inhibit the function of the membrane-bound receptor by blocking ligand-dependent cell transformation (Flickinger et al. 1992).

Alternative splicing can also generate enzyme isoforms with differing enzymatic activities. Different glucokinase isoforms are produced by tissue-specific alternative RNA splicing in liver and pancreatic islet cells (Liang et al. 1991). L1 is major glucokinase isoform found in liver, and B1 in islets. L1 and B1 differ from each other by 15 amino acids at the NH₂ terminus due to occasional skipping of exon 1. The K_m values of the B1 and L1 isoforms are similar, but the V_{max} of the B1 isoform is 2.8 fold higher than that of the L1 isoform. In addition, two minor glucokinase isoforms in liver and islet cells, L2 and B2, generated from mRNAs lacking 51 nucleotides due to the use of an alternate splice acceptor site in the exon 4, lack glucose phosphorylating activity. These results suggest that the alternative splicing of the glucokinase pre-mRNA dramatically affect the enzyme activities

of the gene products.

In a limited number of cases alternative RNA processing gives rise to mature products with totally different functions. Here the alternatively spliced region encodes the major active site of the product. This type of alternative splicing is used in the generation of a number of peptide hormones. The calcitonin gene produces both calcitonin and calcitonin gene-related peptide (CGRP) by alternative splicing and poly(A) addition site usage (Amara *et al.* 1982; Jonas *et al.* 1985). Exons 1-3 contain the 5' untranslated and common coding regions. Exon 4 contains the calcitonin coding sequence and a poly(A) addition site and is used in thyroid. In brain and other neuronal tissue exon 3 is spliced to exons 5 and 6, which contain the CGRP coding region and its 3' untranslated sequences and poly(A) addition site. Translation of these two different mRNAs produces two prehormones; proteolytic cleavages release the two different polypeptides, calcitonin and CGRP. Calcitonin functions in calcium retention while CGRP may have neuromodulatory activity (Fontaine *et al.* 1987).

3. Effects on RNA Stability and Translatability

Many genes produce transcripts with heterogeneity within the 5' and 3'-UTRs. The untranslated sequences are known to be involved in regulating translational efficiency (Kozak, 1991a,b) and RNA stability (Brawerman, 1987). Thus, alternative processing involving untranslated regions provides

the potential for regulated expression of the same gene product in different cells, or for regulating the expression of different products arising from alternative splicing of coding regions. A specific sequence promoting mRNA decay has been identified in the 3' noncoding region. Shaw and Kamen (1986) have shown that the colony-stimulating factor-1 (CSF-1) gene produced two transcripts that were identical in the coding region but differed only in the 3'-UTR. One 3'-UTR contains a repetitive AUUUA element found in a number of rapidly turning over mRNAs, and causes a dramatic destabilizing effect when inserted into the 3'-UTR of β -globin mRNA. This suggests that CSF-1 expression can be regulated at the level of mRNA turnover according to the selection of different 3' untranslated sequences.

The 5'-UTR has been shown to be involved in the regulation of translational efficiency. Many reports indicated that changes in the 5'-noncoding sequence of messages can make translation more or less difficult. The suspicion that complicated leader sequence can impair translation for mRNAs containing alternative 5'-UTRs has been confirmed for some gene transcripts, such as human complement protein C2 (Horiuchi *et al.* 1990), murine tissue inhibitor of metalloproteinases (Waterhouse *et al.* 1990) and rat insulin-like growth factor I (Lowe *et al.* 1987; Foyt *et al.* 1991). Features of the 5'UTRs which can influence translational capacity of the message include: 1) length; 2) the presence of

additional upstream open reading frames; and 3) the presence of secondary structure.

CHAPTER III

METHODS

A. Materials

Enzymes and chemicals were purchased from BRL (Gaithersburg, MD), Promega (Medison, WI), United States Biochemicals (Cleveland, OH) and Sigma (St. Louis, MO). [α - 32 P]dCTP (specific activity 3,000 Ci/mmole), [α - 32 P]UTP (specific activity 400 Ci/mmole) and [35 S]L-methionine (specific activity 1,000 Ci/mmole) were purchased from ICN Biochemicals (Costa Mesa, CA). Nytran filters were from Schleicher & Schull (Keene, NH). N^t-Benzyloxycarbonyl-L-arginyl-L-argine 7-amido-4-methylcoumarin (Z-Arg-Arg-AMC) was from BACHEM Bioscience Inc. (Philadelphia, PA).

Plasmids phCB79-2 (Chan et al. 1986) and phCB96-2 were gifts from Drs. S.J. Chan and D.F. Steiner (University of Chicago, Chicago, IL). The plasmid phCB79-2 (Figure 2) harbors the cDNA for a 2.3 Kb form of human cathepsin B mRNA containing 237 nt 5'-untranslated region (UTR), the coding region for preprocathepsin B, and a 798 nt 3'-UTR, cloned into the *EcoRI* site of plasmid pGEM-2 (Promega). Adjacent to the cathepsin B cDNA is an SP6 promoter to drive mRNA synthesis

A

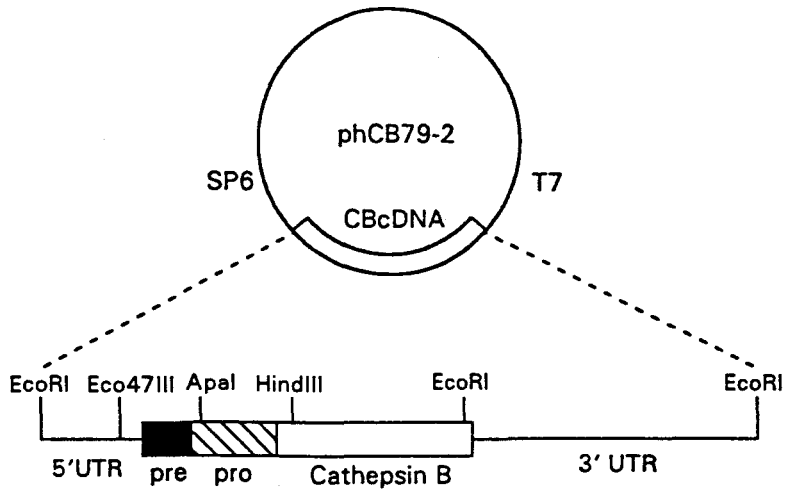

B

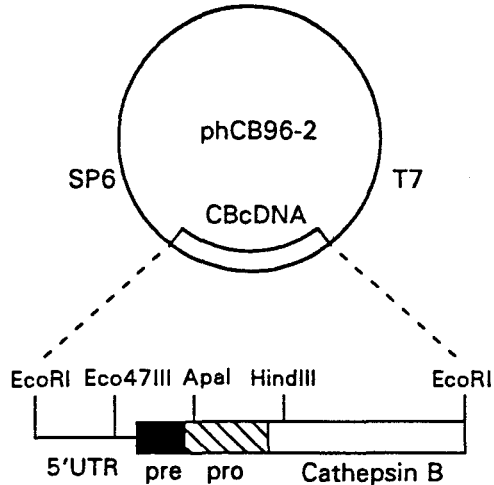

Figure 2: Human cathepsin B cDNAs in plasmids phCB79-2 and phCB96-2. The 5' and 3' UTRs, and coding region for the prepeptide, activation propeptide and mature enzyme in the cathepsin B cDNAs are indicated. Also shown are restriction sites. Panel A shows plasmid phCB79-2 and its cathepsin B cDNA insert. Panel B shows plasmid phCB96-2 and its cathepsin B cDNA insert. The cDNA insert in phCB96-2 is missing an 88 nt segment (exon 2) present in phCB79-2.

and a T7 promoter to drive antisense or cRNA synthesis. A single internal *EcoRI* site interrupts the codon for glycine 328 near the carboxyl-terminus of cathepsin B. Plasmid phCB96-2 (Figure 2) contains a human cathepsin B cDNA which is missing an internal 88 nt segment (exon 2) in the 5'-UTR of phCB79-2, and is bounded at its 3'-end by the same internal *EcoRI* site of phCB79-2 which interrupts the glycine 328 codon. This cDNA fragment is cloned into the *EcoRI* site of the plasmid pGEM-4Z. Positioned at each end of the insert are SP6 and T7 promoters to drive mRNA and cRNA synthesis respectively.

B. Solutions

LB Broth: 10 g peptone (Gibco BRL), 5 g yeast extract (Gibco BRL), 6 g NaCl per liter

SSPE: 10 mM NaH₂PO₄, 0.15 M NaCl, 1.0 mM EDTA, pH 7.4

TBE: 89 mM Tris-borate, 89 mM boric acid, 2 mM EDTA

SSC: 15 mM sodium citrate, 0.15 M NaCl, pH 7.0

TE: 10 mM Tris-HCl, 1 mM EDTA, pH 7.6

DEPC-Treated H₂O: water was treated with 0.1% diethylpyrocarboboate for at least 12 hours and autoclaved.

P1 Buffer: 100 µg/ml RNase A (Sigma), 50 mM Tris-HCl, 10 mM EDTA, pH 8.0

P2 Buffer: 200 mM NaOH, 1% SDS

P3 Buffer: 2.55 M KAc, pH 4.8

QBT Buffer: 750 mM NaCl, 50 mM MOPS, 15% ethanol, 0.15%

Triton X-100, pH 7.0

QC Buffer: 1.0 M NaCl, 50 mM MOPS, 15% ethanol, pH 7.0

QF Buffer: 1.25 M NaCl, 50 mM MOPS, 15% ethanol, pH 8.2

C. Cell Culture

Tumor cells used in these studies included a cultured human colon carcinoma (from L.C. Erickson, Loyola University of Chicago, Stritch School of Medicine), human melanomas A375P and A375M (from I.J. Fidler, Anderson Hosp. and Tumor Inst.), and human prostate carcinomas PC3P and PC3M (from J. Kozlowski, Dept. of Urology, Northwestern Med. Sch.). The variant A375M and PC3M were derived from the parental lines A375 (A375P) and PC3 (PC3P) respectively by culturing cells derived from experimentally produced metastatic lung tumor nodules. The variants A375M and PC3M were more metastatic than the parent cells after i.v. injection (experimental metastasis) and after s.c. transplantation (spontaneous metastasis) into young nude mice (Kozlowski et al. 1984). The melanomas A375P and A375M were cultured in Minimum Essential Medium supplemented with Earle's salts, essential amino acids, vitamins, sodium pyruvate (110 mg/L), penicillin (100 units/ml), streptomycin (100 μ g/ml), sodium bicarbonate (2.2 g/L), and fetal bovine serum (10%). The prostate carcinomas PC3P and PC3M, and colon carcinoma were cultured in RPMI 1640 supplemented with penicillin (100 units/ml), streptomycin (100 μ g/ml) and fetal bovine serum (10%). 70-80% confluent cells

were subcultured by scraping into 10 ml of serum free media, pelleting at 500xg and resuspending in fresh media containing 10% fetal bovine serum. The media were changed three times weekly.

D. Human Tissues

Normal human kidney, spleen, liver, colon and breast tissues, and samples of several solid tumors were provided by the Cooperative Human Tissue Network and the National Disease Research Interchange. The tissues were reported to have been snap frozen at the time of collection and stored at -70°C . Pathological reports were provided for each tumor specimen.

E. Total RNA Isolation

Total RNAs were prepared from normal human tissues and solid tumors, and from cultured cells with a method described by Chomczynski and Sacchi (1987). Briefly, the cell pellet or tissue was crushed in liquid nitrogen and homogenized in denaturing solution containing 4M guanidinium thiocyanate, 25 mM sodium citrate, pH 7.0, 0.5% sarcosyl, and 0.1 M 2-mercaptoethanol. Sequentially, 0.1 volume of 2.0 M sodium acetate, pH 4.0, 1 volume of phenol, and 0.2 volume of chloroform-isoamyl alcohol mixture (49:1) were added to the homogenate. The aqueous phase was collected by centrifugation and the RNA in the aqueous phase was precipitated with an equal volume of isopropanol and washed with 70% ethanol. The

RNA was redissolved in diethyl pyrocarbonate (DEPC)-treated water and its integrity was examined by electrophoresis in an agarose gel (Fourney et al. 1988).

F. Quantification of Cathepsin B mRNA

The RNA dot blot procedure was used to quantify cathepsin B mRNA. Total RNA from normal human tissues and tumor cells were dissolved in a denaturing solution (50% formamide and 10x SSC) and heated at 65°C for 15 min. Varying amounts (0.1 µg to 10 µg) of denatured RNA were spotted onto Nytran filters. For a cDNA probe pHCB79-2 was digested with *EcoRI*, and was fractionated by electrophoresis in 0.7% agarose gel. The DNA fragment containing human cathepsin B sequence was eluted from the gel slice by centrifugation through a 1.5 ml polypropylene tube which had a hole at bottom and a small amount of glass wool as a cushion. The collected DNA was then extracted with 1 volume of phenol/chloroform and precipitated by ethanol. The DNA pellet was redissolved in the TE buffer. The approximate concentration of the purified DNA fragment was determined by agarose gel electrophoresis and comparison to known amounts of DNA standards. The purified fragment was labeled with ³²P-dCTP by the random primer labeling method according the Protocols and Applications Guide provided by Promega. Twenty ng of the DNA fragment in 30 µl of water was heated at 100°C for 3 min, and chilled on ice for 5 min. After addition of 10 µl of 5X labeling buffer, 2 µl of a

mixture of the unlabeled dNTPs (500 mM each of dATP, dTTP, dGTP), 2 μ l of acetylated BSA (10 mg/ml), 5 μ l of [α -³²P]dCTP (3,000 Ci/mmol, 10 mCi/ml) and 5 units of Klenow enzyme (Promega), the mixture was incubated at room temperature for 1 hour. The reaction was then terminated by heating at 100°C for 3 min and chilling on ice for 5 min. After addition of 2 μ l of 0.5 M disodium ethylenediamine tetraacetate (EDTA) and 48 μ l of water, the labeled DNA fragment was separated from unincorporated [α -³²P]dCTP by a Shephadex G-50 spun-column chromatography (Maniatis et al. 1987). The purified labeled probe was used in hybridization.

The Nytran filter was prehybridized for 4 hours in a solution containing 50% formamide, 5X Denhardt's solution (Maniatis et al. 1987), 0.25 mg/ml of denatured salmon sperm DNA, 1.0% SDS, 1.0 M NaCl, 10 mM Na₂HPO₄ and 0.1% tetrasodium pyrophosphate. Hybridization was done at 42°C overnight in a fresh mixture of the same solution to which ³²P-labeled human cathepsin B cDNA was added. After hybridization, the filter was washed three times (30 min each time) in 0.2x SSC and 0.5% SDS at 65°C, and exposed to Kodak XAR film. To rehybridize the blot, the cathepsin B probe was removed by washing the filter three times in 0.01X SSPE and 0.5% SDS at 95°C for 30 min. For the internal standard control, the stripped filter was similarly hybridized with ³²P-labeled cDNA corresponding to the chicken 18s rRNA.

G. Northern Blot Analysis

Total RNAs were denatured with formamide and formaldehyde and subjected to electrophoresis in a 1.1% agarose/0.02% formaldehyde gel in 3-[N-morpholino] propanesulfonic acid (MOPS) buffer (0.02 M MOPS, 5.0 mM sodium acetate, 1.0 mM EDTA, pH 7.0) (Fourney et al. 1988). The RNAs were transferred to Nytran filter, and the filter was hybridized as described above.

H. RNase Protection Assay

Protection assays were performed using a modification of a described method (Lowe et al. 1987). The RNase protection assay, outlined in Figure 3, depends on the production of a complementary RNA probe of high specific radioactivity which hybridizes to homologous sequences in mRNA. The resulting regions of double strand RNA are resistant to digestion by RNase T1 and RNase A. Single stranded regions in the labeled RNA probe which do not complement the message are degraded. Labeled RNA fragments of characteristic size are produced which correspond to specific mRNA species present in the sample. These labeled fragments can be analyzed for size by electrophoresis in a denaturing gel.

For construction of the riboprobe vector, a 445-bp *EcoRI/HindIII* cDNA insert, containing sequence corresponding to the entire 5'-untranslated region of the human cathepsin B mRNA (Figure 4), was isolated from pHCB79-2, and ligated into

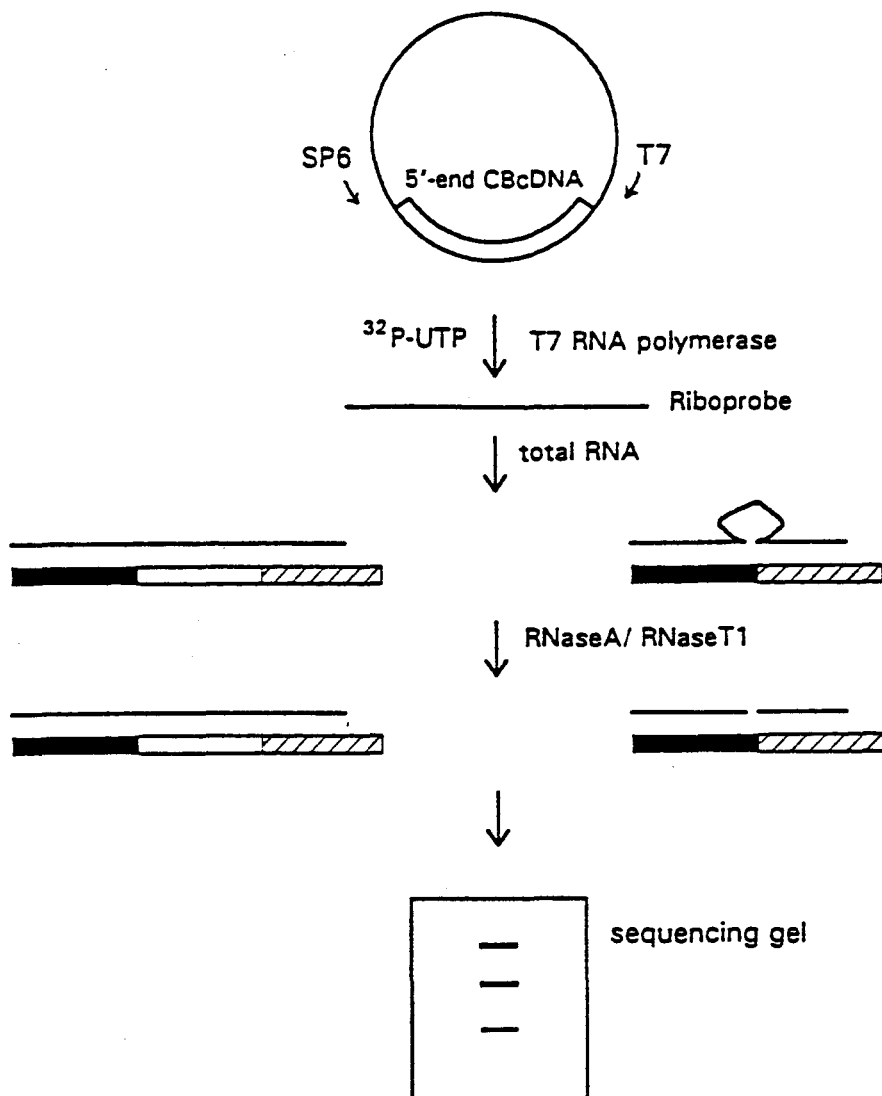

Figure 3. Scheme for RNase protection assay. A DNA fragment containing 5'-end of human cathepsin B cDNA was cloned into pGEM-2. A radioactive antisense RNA probe was synthesized using T7 RNA polymerase and $[\alpha\text{-}^{32}\text{P}]\text{UTP}$ as described in methods. The resulting antisense RNA was purified and then incubated with total RNA for annealing. RNase A and RNase T1 was added to digest single strand RNA. The protected double stranded fragments were analyzed by electrophoresis on a denaturing gel.

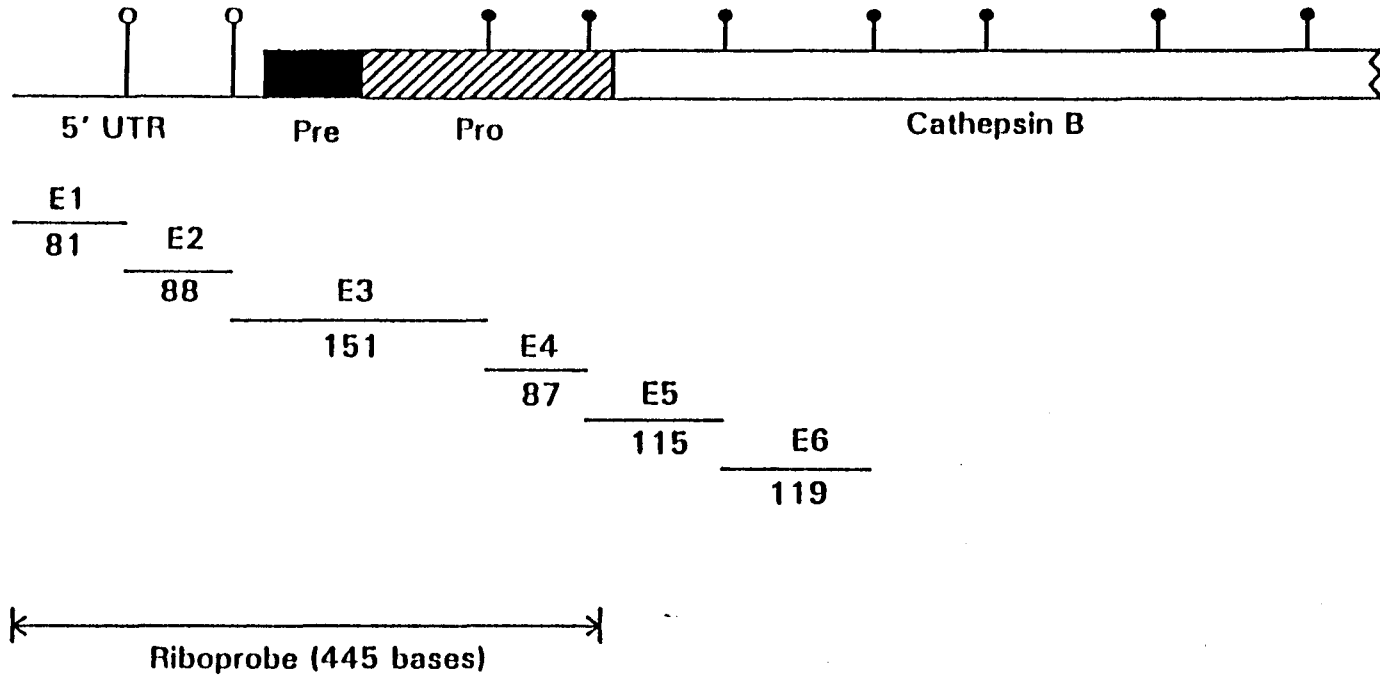

Figure 4: The riboprobe for RNase protection assay. The organization of a human cathepsin B mRNA, and the sizes of first six exons are shown. A 445 nt antisense RNA (riboprobe), complementary to the sequence from exon 1 to the middle of exon 5 of the cathepsin B mRNA, was synthesized for the RNase protection assay outlined in Figure 3.

a pGEM-2 vector (Promega) previously cut with *EcoRI*/*HindIII*. After linearizing the plasmid with *EcoRI*, the human cathepsin B riboprobe was synthesized in 20 μ l reaction mixture containing 1.5 μ g DNA template, 40 mM Tris-HCl (pH 7.5), 6 mM $MgCl_2$, 10 mM NaCl, 2 mM spermidine, 10 mM dithiothreitol, 40 units RNasin, 50 mM each of CTP, ATP and GTP, 20 μ M UTP, 5 μ M ^{32}P -UTP (50 μ Ci, 400 Ci/mmol), and 20 units T7 RNA polymerase according to the Protocols and Application Guide provided by Promega. The mixture was then incubated at room temperature for 2 hours. After transcription, 1 μ g of DNase I (BRL) and 1 μ l of 200 mM vanadyl-ribonucleoside complex (BRL) were added, and the mixture was incubated for 15 min at 37°C. The mixture was then extracted with 0.5 vol of phenol and 1 vol of chloroform and subjected to purification by a polyacrylamide gel electrophoresis. After running the 8% polyacrylamide/8 M urea denaturing gel, the 445-base riboprobe was located by autoradiography and eluted from a gel slice in 400 μ l buffer (2 M ammonium acetate, 1% SDS and 25 μ g/ml tRNA). The labeled riboprobe was precipitated with 2 volume of 100% ethanol, dried in vacuum and resuspended in DEPC treated water.

The RNAs used in the assays were precipitated from 0.5 M NaCl with 2 volume of ethanol, recovered by centrifugation, and dried in vacuum. 20 μ g of total RNA was resuspended in 29.5 μ l of hybridization buffer (20 mM Tris-HCl, pH 7.6, 1 mM EDTA, 0.4 M NaCl, 0.1% SDS, and 75% deionized formamide) to which 0.5 μ l of H_2O containing 500,000-700,000 cpm of the

labeled riboprobe was added. The mixture was heated to 85°C for 5 min and incubated at 45°C for about 16 hr. After hybridization, 270 μ l of RNase digestion buffer (10 mM Tris-HCl, pH 7.6, 5 mM EDTA, 300 mM NaCl, 40 μ g of RNase A per ml (Sigma), and 2 μ g of RNase T1 per ml (BRL)) was added, and the mixture was incubated for 1 hr at 30°C. SDS was then added to a final concentration of 0.6% followed by addition 50 μ g of proteinase K. The mixture was incubated at 37°C for 15 min, and then extracted with 0.5 volume of phenol and 1 volume of chloroform. Twenty μ g of tRNA and 2 volume of ethanol were added to the aqueous layer. After 30 min at -20°C, the precipitate was collected by centrifugation, dried, and resuspended in formamide sample buffer (80% deionized formamide and 0.2% of bromophenol blue). The sample was heated to 95°C for 3 min, chilled on ice, and applied to an 8% polyacrylamide/8 M urea denaturing gel. After electrophoresis at 50°C in 0.5x TBE, the gel was dried and exposed to Kodak XAR film at -70°C overnight. RNA bands, corresponding to the alternative 5'-UTRs were quantitated by densitometry, and their sizes estimated by comparing their mobilities with those of DNA markers.

I. Polymerase Chain Reaction (PCR) Amplification of cDNA

The first strand cDNA was synthesized with the SuperScript™ RNase H Reverse Transcriptase (BRL) from total RNA using random primers according the method described by

Kawasaki (1991). The reaction mixture contained 1 μ g total RNA, 100 pmole of random primer mixture (Pharmacia, Alameda, CA), 40 units RNasin, 1.0 mM each of dCTP, dATP, dCTP and dGTP, and 200 units of SuperScript™ RNase H⁻ Reverse Transcriptase in a final volume 20 μ l. Then the mixture was incubated at room temperature for 10 min and at 42°C for 1 hour. Four μ l of this reaction mixture was used directly as template for PCR. To amplify the 5' region of cathepsin B cDNA, PCR was performed with a pair of specific oligonucleotide primers having the *Hind*III and *Eco*RI restriction sites at their termini to facilitate subcloning; the primers were 5'GGGGATCCAACCGCTCCGCTGCGCGC (sense) in exon 1, and 5'GGGAATTCGGTGTGGATGCAGATCCG (antisense) in exon 5 (Figure 5). The resulting fragment was subcloned into the *Hind*III/*Eco*RI site of the pBluescrip vector (Stratagene, La Jolla, CA) to give pHcBe1.4. For amplifying the cathepsin B cDNA missing exons 2 and 3, the sense primer, 5'CAGCGCTGGGCCGGGCAC, was complementary to 9 nucleotides on each side of the exon 1-exon 4 junction, and the antisense primer was 5'CCAGGACTGGCACGACAGGC and complementary to a sequence present in the flanking 3' untranslated region of all known, full length cathepsin B mRNAs (Figure 6). The reaction mixture contained 4 μ l of the template solution (see above), 2.5 units of Taq polymerase (United States Biochemicals), 400 nM of each primer, 10 mM Tris-HCl, pH 8.3, 50 mM KCl, 1.5 mM MgCl₂, 0.1 mg/ml gelatin, 0.01% Tween 20 and 0.01% NP-40 in a

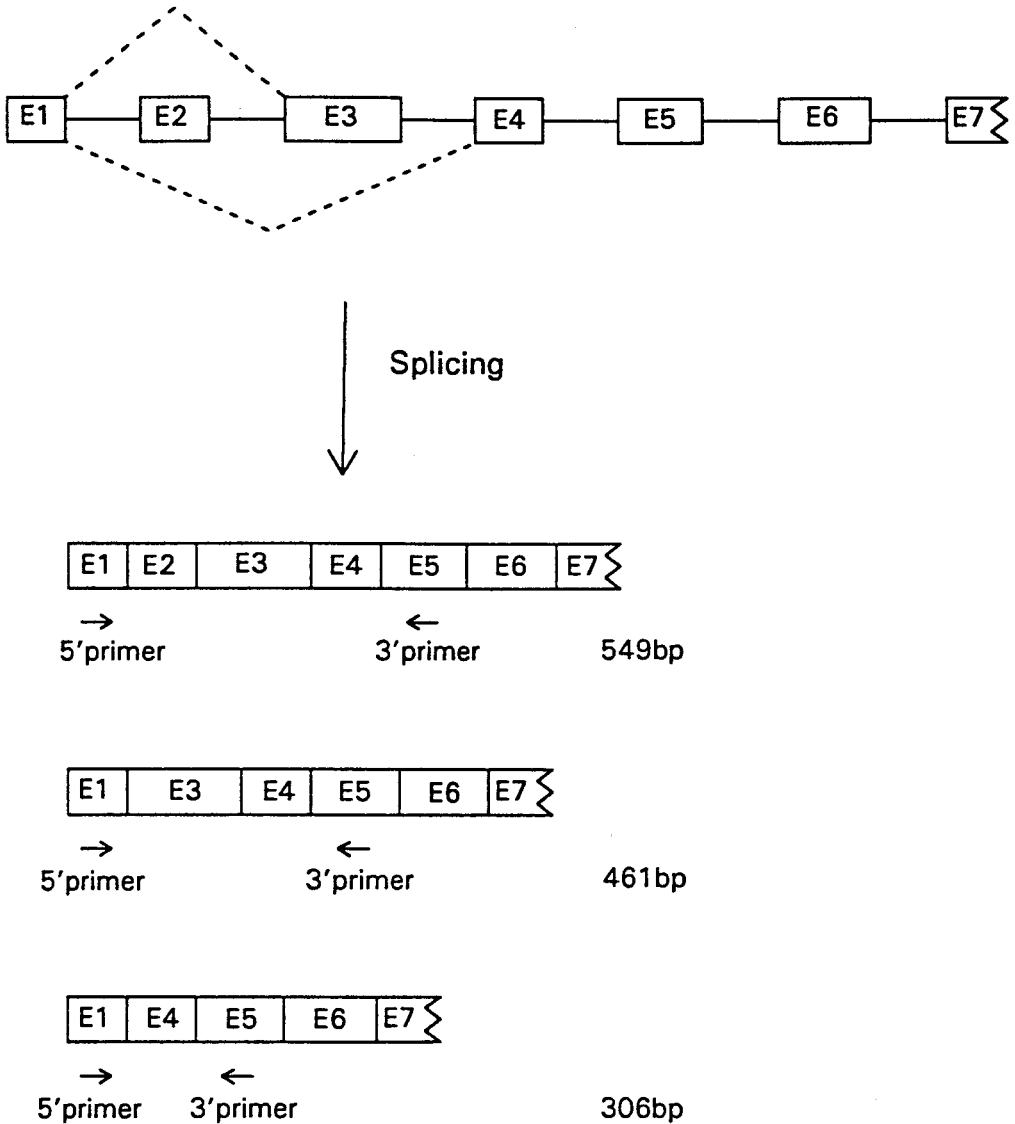

Figure 5. Scheme for PCR amplification of 5'-end of cathepsin B cDNA. Alternatively spliced forms of human cathepsin B mRNA are shown. The 5' (sense) and 3' (antisense) primers used in PCR were complementary to the indicated regions in exons 1 and 5 respectively. PCR products of 549 bp, 461 bp and 306 bp are expected after amplification of the cDNAs containing the full length 5' UTR, those missing exon 2, and those missing exons 2 and 3, respectively.

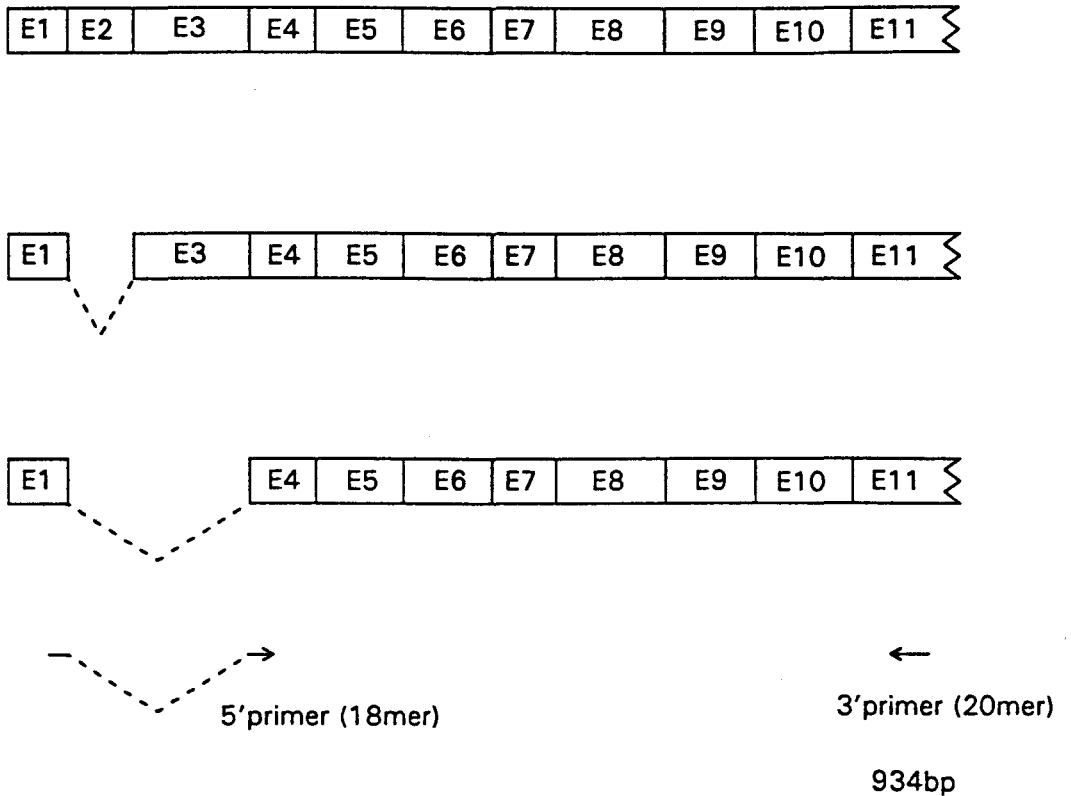

Figure 6. Scheme for the PCR amplification of cathepsin B cDNA missing exons 2 and 3. Three cathepsin B transcripts which result from alternative splicing in their 5' regions are shown. The cDNA for the transcript lacking exon 2 and 3 was amplified with a sense primer which is complementary to the sequence of the exon 1-exon 4 junction, and an antisense primer which is complementary to the sequence in the exon 11 (3'-untranslated region). A 934 bp PCR product is expected.

final volume 100 μ l. Cycling was performed in a Eppendorf DNA thermal cycler with a profile of 30 sec at 95°C, 1 min at 65°C, and 2 min at 72°C for 30 cycles. Ten μ l of the reaction product were analyzed by agarose gel electrophoresis, transferred onto a Nytran filter, and the filter hybridized with 32 P-labeled human cathepsin B cDNA.

J. Sequencing of PCR Fragments

PCR reaction products were isolated, digested with *Hind*III and *Eco*RI and subcloned into the pBluescript vector for single strand sequencing by the dideoxy chain termination method (Sanger *et al.* 1977).

The single strand DNA was prepared with the method described by Russel *et al.* (1986). The HB101[F⁺] cells containing pCBel.4 plasmid were patched onto LB plates containing 100 μ g ampicillin/ml and incubated overnight at 37°C. A portion of each patch was used to inoculate 1.5 ml modified LB broth (16 g tryptone, 10 g yeast extract, 5 g NaCl per liter) plus glucose (0.1%) and 100 μ g ampicillin/ml in a culture tube, giving visible turbidity to the solution. Next 5×10^9 - 10^{10} of helper phage R408 (Promega) were added. The cultures were incubated at 37°C with vigorous agitation for 4-5 h. After centrifuging the infected culture, the 1.3 ml of the supernatant was transferred to a tube containing 0.2 ml of 2.5 M NaCl and 20% polyethyleneglyco-6000 (PEG-6000) and incubated at room temperature for 15 min. The mixture was

then centrifuged in a microfuge for 5 min at room temperature. The supernatant was removed by aspiration, and the tube was briefly recentrifuged to remove the remaining trace of liquid. The pellet was resuspended in 100 μ l of 10 mM Tris-HCl, pH 8.0, containing 2mM EDTA, and extracted with 50 μ l of phenol. The aqueous phase was collected by centrifugation, and the single strand DNA in the aqueous phase was precipitated with 250 μ l of a 25:1 mixture of ethanol and 3 M sodium acetate, washed with absolute ethanol, dried at 65°C for 10 min and dissolved in 20 μ l of TE solution. The single strand DNA was then sequenced with Sequenase Version 2.0 (United States Biochemicals) according the manufacturer's instruction.

K. Construction of Expression Vectors

SP6/cathepsin B mRNA expression vectors were made by inserting cathepsin B cDNA into pGEM2 (Promega) vector adjacent to the SP6 promoter, using standard cloning procedures. The insert and vector DNAs were prepared by restriction enzyme digestion (Maniatis et al, 1987). Each digestion mixture contained 5 μ g of plasmid DNA, 5 μ l of appropriate restriction 10x buffer, 10-25 units of appropriate restriction enzyme in final volume of 50 μ l. The mixture was incubated at 37°C for 1-3 h. The reaction end point was verified by electrophoresis of an aliquot of the sample on an agarose gel. After restriction enzyme digestion, the vectors and inserts were separated by agarose gel electrophoresis, and

the DNA fragments were eluted from the agarose gel by centrifugation (see above). The vector and insert were then ligated overnight at 14°C with 1 unit of T4 ligase (BRL) in the assay buffer provided by the manufacturer. The ligated DNA was transformed in *E.coli* strain HB101. Ampicillin resistant clones were selected, plasmid was prepared, and samples were analyzed by restriction digestion.

The construction of phCB79-2-2 is outlined in Figure 7. It contains the shorter 5'-UTR lacking exon 2 from phCB96-2, the entire preprocathepsin B coding sequence, and the shorter 3'-UTR from plasmid phCB79-2. Briefly, a 357 bp *EcoRI/HindIII* fragment from phCB96-2, containing exons 1, 3, 4 and part of exon 5, was inserted into *EcoRI/HindIII* site of pGEM-2 vector (Promega) to make plasmid phCBe1.3.4.5. phCB79-2-2 was constructed by replacing a sequence from *NheI* site to *ApaI* site of phCB79-2 with 593 bp *NheI/ApaI* fragment from phCBe1.3.4.5. phCB79-2-2,3 is identical to phCB79-2-2 except that it is also missing exon 3. Its preparation is described in Figure 8. A 87 bp *Eco47III/ApaI* fragment from phCBe1.4, containing part of exon 1 and part of exon 4, was used to replace the corresponding sequence from the *Eco47III* to the *ApaI* site in the phCB96-2 to make phCB96-2-3. A 206 bp *EcoRI/HindIII* fragment from phCB96-2-3 was isolated and inserted into the *EcoRI/HindIII* site of pGEM-2, to give phCBe1.4.5. Then phCB79-2-2.3 was constructed by replacing the sequence from the *NheI* site to the *ApaI* site of phCB79-2

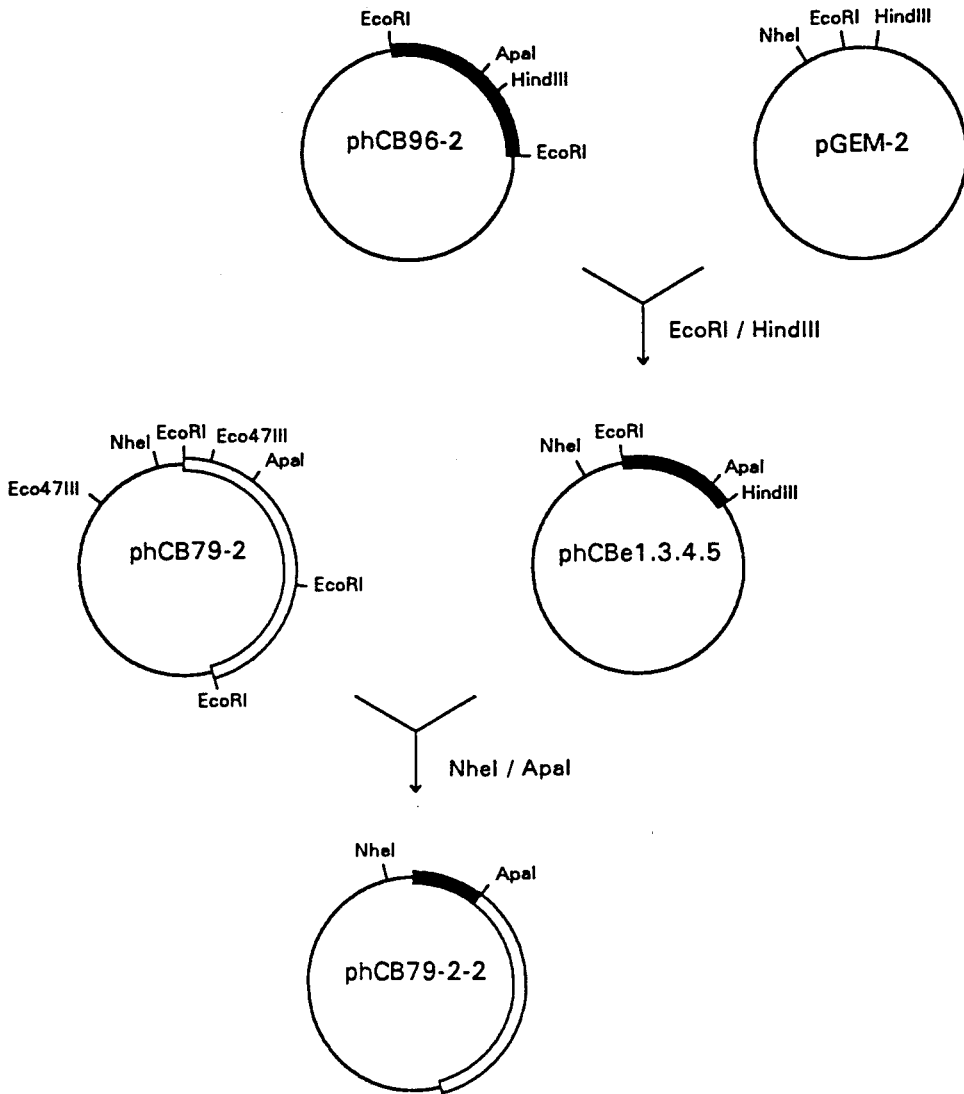

Figure 7. Scheme for the construction of plasmid phCB79-2-2. phCB79-2-2, containing a cathepsin B cDNA lacking exon 2, was constructed from phCB96-2 and phCB79-2 in two steps. First, a 357 bp fragment from phCB96-2 was excised with *EcoRI* and *HindIII*, and ligated into the *EcoRI/HindIII* sites of a pGEM-2 vector to make phCB79-2-2. To make phCB79-2-2 a 593 bp fragment was removed from phCB79-2-2 with *NheI* and *ApaI* and ligated into the corresponding *NheI/ApaI* site of phCB79-2. Restriction enzymes used for subcloning in each step are indicated. The cathepsin B cDNA fragment in each vector is shown by double lines. Also shown are restriction sites in each vector.

Figure 8. Scheme for the construction of plasmid phCB79-2-2.3

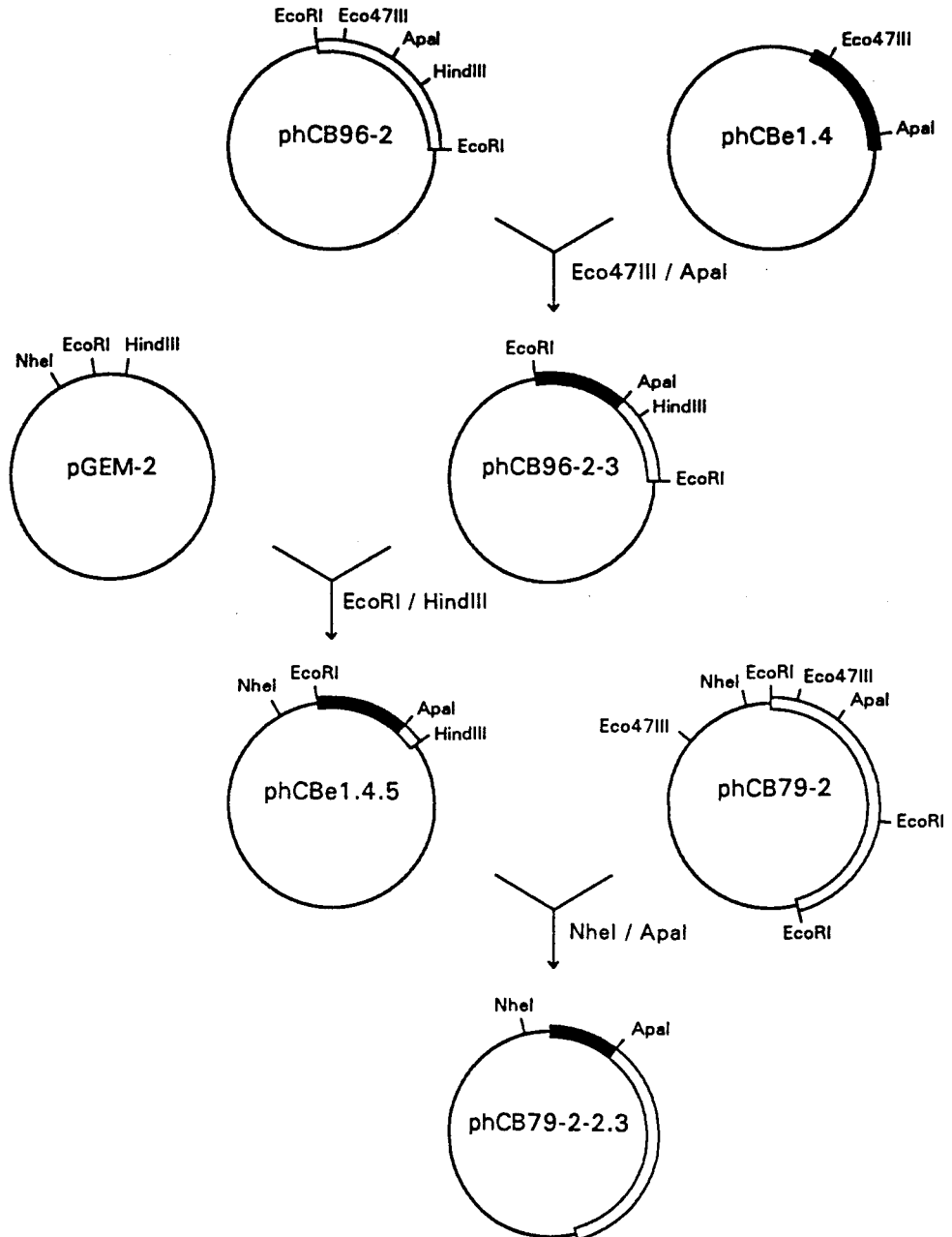

Figure 8. Scheme for the construction of plasmid phCB79-2-2.3. phCB79-2-2.3, containing cathepsin B cDNA lacking exons 2 and 3 was constructed from phCBe1.4, phCB96-2 and phCB72-2 in three steps. First, an 87 bp fragment from phCBe1.4 was removed with *Eco47III* and *ApaI*, and ligated into the *Eco47III/ApaI* site of phCB96-2 in place of a corresponding region to make phCB96-2-3. Second, a 206 bp *EcoRI/HindIII* fragment from phCB96-2-3 was ligated into the *EcoRI/HindIII* sites of pGEM-2 vector to make phCBe1.4.5. Finally, a 442 bp *NheI/ApaI* fragment from phCBe1.4.5 was used to replace the corresponding *NheI/ApaI* segment of phCB79-2 to give phCB79-2-2.3. Restriction enzymes used for subcloning in each step are indicated. The cathepsin B cDNA fragment in each vector is shown by double lines. Also shown are restriction sites in each vector.

with the 442 bp *NheI*/*ApaI* fragment from pHCBe1.4.5.

L. In Vitro Transcription and Translation

Plasmids were isolated by chromatography on QIAGEN columns (QIAGEN Inc., Chatsworth, CA) according to the manufacturer's instruction. Two hundred ml of LB broth containing 100 μ g ampicillin/ml was inoculated with *E.coli* transformed by the appropriate plasmid, and incubated at 37°C overnight with vigorous agitation. The cells were pelleted by centrifugation, resuspended in 4 ml of P1 buffer to which 4 ml of P2 buffer was added, and incubated at room temperature for 5 min. After addition of 4 ml of P3 buffer, the mixture was centrifuged at 4°C for 30 min (15,000xg). The supernatant was then removed and applied onto a QIAGEN-tip 100 column, which was preequilibrated with 3 ml of QBT buffer. The column was next washed with 10 ml of QC buffer, and the plasmid DNA eluted with 5 ml of QF buffer. The collected DNA was precipitated with 0.7 volume of isopropanol, washed with 70% ethanol and dissolved in TE buffer.

For *in vitro* transcription, the isolated plasmid DNA was linearized with *XbaI*, and purified by phenol-chloroform extraction and ethanol precipitation. Each transcription reaction contained 5 μ g of the appropriate linearized vector, 10 μ l 5X transcription buffer (Promega), 10 mM dithiothreitol, 50 units RNasin, 0.5 mM each of ATP, CTP, and UTP, 0.05 mM $m^7G(5')ppp(5')G$ and 40 units of SP6 RNA polymerase in final

volume of 50 μ l. To estimate RNA synthesis, a 3 μ l aliquot of the complete reaction mixture was added to 10 μ Ci of dried [γ -³²P]UTP prior to the start of the reaction. After incubation at 37°C for 1 hour, the transcripts were purified by phenol-chloroform extraction and ethanol precipitation, dissolved in DEPC-treated water and stored at -20°C. After each purification step, portions of these samples were analyzed on a Northern blot to ensure that no loss or degradation of the RNA had occurred. Reaction mixtures containing radiolabeled UTP were treated with 10 μ g of tRNA and 5% trichloroacetic acid, and the insoluble radioactivity measured with a Beckman LS7500 liquid scintillation spectrometer to determine the amount of RNA transcribed.

For *in vitro* translation, 100 ng to 300 ng of capped mRNA was heated at 65°C for 15 min, added to a reaction mixture containing 35 μ l of rabbit reticulocyte lysate, 40 units of RNasin ribonuclease inhibitor, an amino acid mixture (minus methionine), 0.02 mM each, and 4 μ l of [³⁵S]methionine (1,100Ci/mmol) at 10 mCi/ml on a final volume of 50 μ l. The reaction mixture was then incubated at 30°C for various times from 15 to 60 min. All samples were kept at 4°C before and immediately after translation.

M. Analysis of the Translation Products

Five μ l samples from each translation mixture were diluted to 10 μ l in an electrophoresis sample buffer

containing 0.125 M Tris-HCl (pH 6.8), 2% SDS, 2% 2-mercaptoethanol, 20% glycerol and 0.001% bromphenol blue, boiled for 3 min, and electrophoresed on a 10% polyacrylamide SDS gel in an electrode buffer (pH 8.3) which contained 0.025 M Tris, 0.192 M glycine and 0.1% SDS (Laemmli, 1970). Gels containing the ³⁵S-labeled translation products were dried and autoradiographed overnight at -70°C using an intensifying screen and Kodak XAR film (Laskey, 1980).

To measure [³⁵S]methionine incorporation, a 2 μl aliquot of each translation reaction was incubated in 250 μl of 1N NaOH, 2% H₂O₂ at 37°C for 10 min. After addition of 1.0 ml of ice-cold 25% trichloroacetic acid/2% casamino acids, the samples were incubated on ice for 30 min. The precipitates were collected on Whatman GF/A filters by vacuum filtration, washed with 3 ml of 5% TCA three times and once with 2 ml of acetone, dried, and the radioactivity measured with a Beckman LS7500 liquid scintillation spectrometer.

N. Folding of an *In Vitro* Translation Product

Plasmid pHCB79-2-2.3 was used as a template for preparation of m⁷G(5')ppp(5')G capped synthetic RNA as described above. The *in vitro* translation was described in the previous section, except that the reaction mixture contained 0.6 μg of synthetic, capped mRNA and a complete mixture of amino acids (0.02 mM each) in a final volume of 109 μl.

To promote folding of the translation product, the *in*

in vitro translation mixture (109 μ l) was dialyzed against buffer (0.05 M Tris-HCl, 20% glycerol, 0.1 mg/ml bovine serum albumin, 0.15 M NaCl, 1 mM dithiothreitol, and 0.1 mM Na₂EDTA) to which had been added 6.0 M guanidinium hydrochloride. At intervals of 10 minutes or 30 minutes the dialysis buffer was removed, diluted with an equal volume of buffer to reduce the guanidinium hydrochloride by half, and the dialysis continued for two additional cycles of dilution. The final cycle was followed by dialysis against buffer only (Hager and Burgess, 1980; Vinson et al. 1988). The samples were clarified by centrifugation at 14,000 x g for 15 min, quick frozen, and store at -20°C for later analysis.

In an alternative procedure, some samples (108 μ l) were treated with 12 μ l of a 10X "oxido-shuffling" redox buffer (1X contains 0.15 M Tris-HCl, pH 8.0, 1 mM Na₂EDTA, 0.3 mM glutathione disulfide, and 3.0 mM reduced glutathione) and incubated at room temperature for 24 hours (Jaenicke and Rudolph). Sample were frozen and stored as described above. These procedures are summarized in Figure 9.

O. Measurement of Cathepsin B Activity

Cathepsin B activity was measured using the fluorogenic substrate N^ε-Benzyloxycarbonyl-L-arginyl-L-arginine 7- amido-4-methylcoumarin (Z-Arg-Arg-AMC) (Achkar et al. 1990). The enzyme was converted to its free thiol form by preincubation with dithiothreitol and EDTA. A 50 μ l sample was incubated

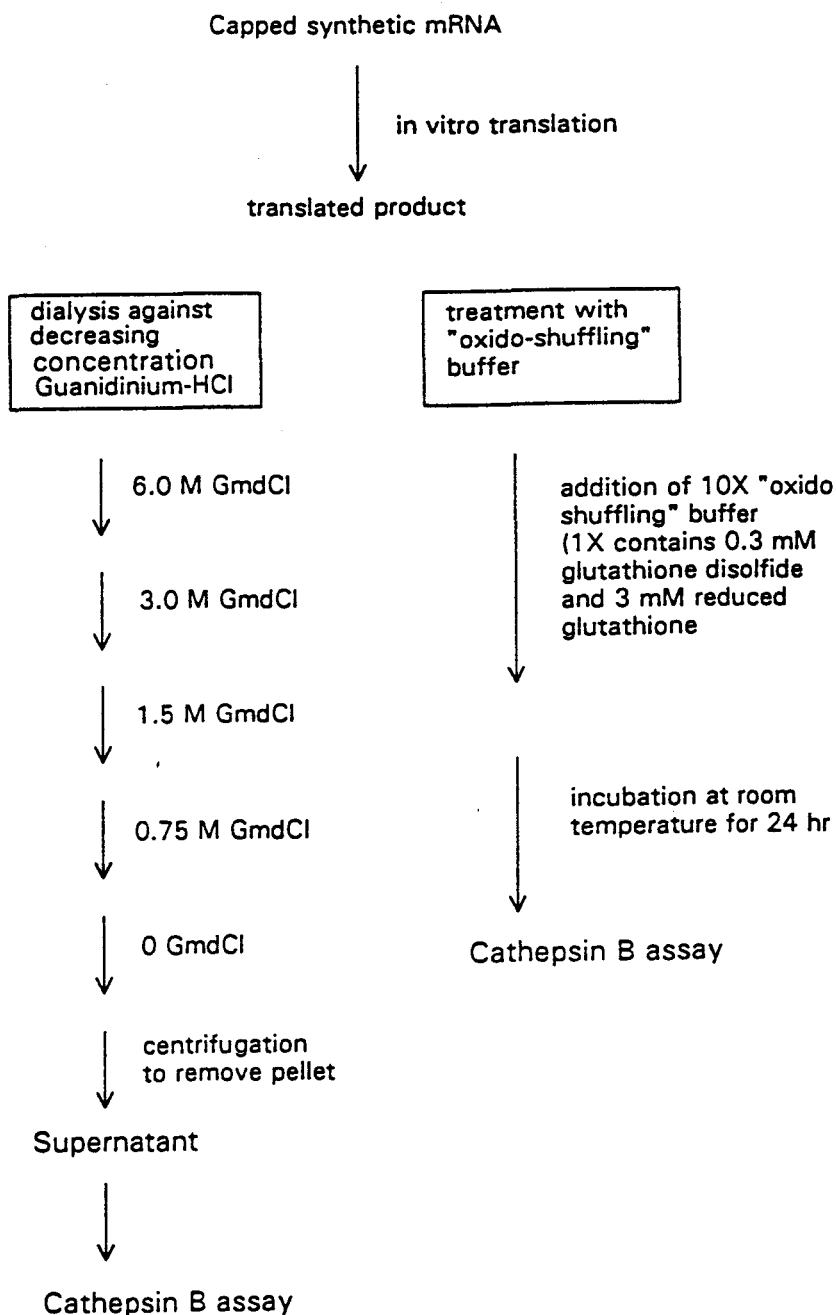

Figure 9. Procedure for folding of translation products *in vitro*. *In vitro* translated products were treated in one of two ways to promote proper folding: with an "oxido-shuffling" buffer to facilitate disulfide bond formation; and with decreasing concentration of guanidinium hydrochloride with changes at 10 and 30 min intervals.

with an equal volume of activation buffer containing 30 mM dithiothretol and 15 mM EDTA, pH 5.2, for 30 min at 25°C. Then 37.5 μ l of 0.6 M citrate/phosphate buffer, pH 6.2 was added, and the reaction was initiated by the addition of 12.5 μ l of the substrate (1.128 mM in dimethyl sulfoxide (DMSO)) at a final concentration of 94 μ M and 8.3% DMSO. The AMC product was quantitated with an SLM/Aminco SPF-500C spectrofluorometer at excitation and emission wavelengths of 370 and 460 nm, respectively. Some samples were also pretreated for 30 min at 37°C with pepsin (0.83 mg/ml) to remove the remainder of the activation propeptide prior to assay (Achkar *et al.* 1990; Rowan *et al.* 1992).

CHAPTER IV

RESULTS

A. Quantification of Total Cathepsin B mRNA in Human Normal Tissues and Tumors by Slot Blot Analysis

Cathepsin B mRNA in different normal human tissues and human tumors was quantified by hybridization of RNA slot blots with labeled human cathepsin B cDNA from pHCB79-2 as the probe. Total RNAs were isolated from five kinds of normal human tissues, skeletal muscle, kidney, liver, spleen and colon, and from two cultured human melanoma cells, A375P and A375M (Chomezynski and Sacchi, 1987). Agarose gel electrophoresis of the total RNAs was performed following denaturation with formamide and formaldehyde. The integrity of the 18S and 28S ribosomal RNA indicated that the isolated RNAs were largely intact.

Figure 10A shows a representative slot blot result for cathepsin B mRNA in five normal human tissues and two melanoma cells. The specificity of the cDNA probe was verified by a Northern blot (Figure 11), which shows that the probe only hybridized to cathepsin B mRNAs. Cathepsin B mRNA levels in A375 melanoma variants are higher than those in all the normal tissues examined. A375M, which is highly metastatic, shows a

Figure 10. Slot blot hybridization analysis of human normal tissues and cultured melanoma cells for levels of cathepsin B mRNA

Panel A, Total RNAs were isolated from normal human tissues, skeletal muscle, kidney, liver, spleen and colon, and two cultured human melanoma cells, A375P and A375M. 10 μ g, 1 μ g or 0.1 μ g of total RNA was loaded onto Hytran filter, and the filter was hybridized with 32 P-labeled human cathepsin B cDNA. Panel B, To ensure equal RNA (μ g) of RNA in all the slots, the blot was stripped and rehybridized to a control probe, the 32 P-labeled cDNA of β -actin.

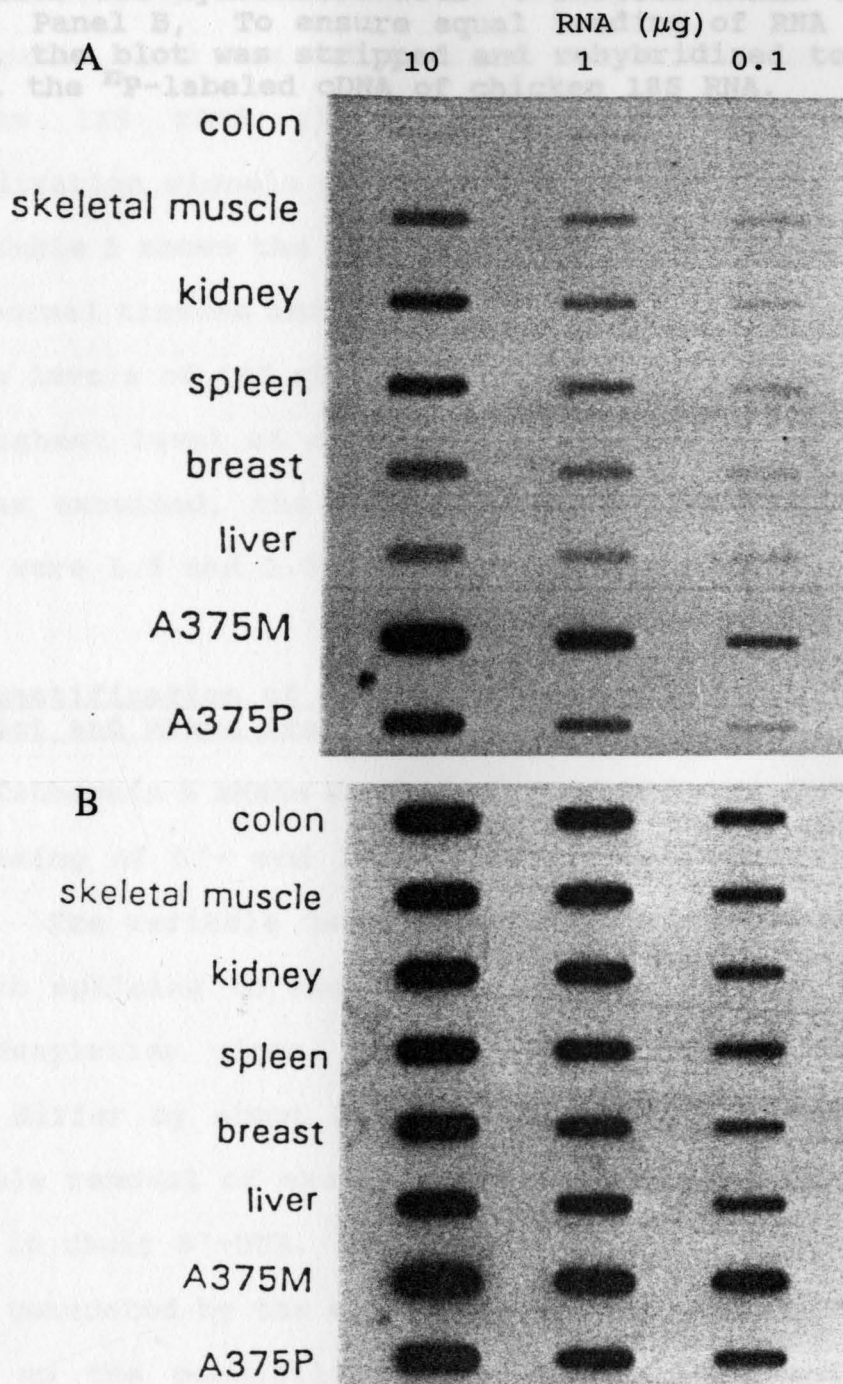

Figure 10. Slot blot hybridization analysis of human normal tissues and cultured melanoma cells for levels of cathepsin B mRNA. Panel A, Total RNAs were isolated from normal human tissues, skeletal muscle, kidney, liver, spleen and colon, and two cultured human melanoma cells, A375P and A375M. 10 μ g, 1 μ g or 0.1 μ g of total RNA was loaded onto Nytran filter, and the filter was hybridized with 32 P-labeled human cathepsin B cDNA. Panel B, To ensure equal loading of RNA in all the slots, the blot was stripped and rehybridized to a control probe, the 32 P-labeled cDNA of chicken 18S RNA.

higher expression of cathepsin B mRNA than A375P which is poorly metastatic, even after adjustments for differences in loading. To ensure that similar amounts of RNAs were present in each sample, the filter was stripped of the cathepsin B cDNA probe, and was rehybridized to a cDNA probe for the chicken 18S rRNA (Figure 10B). Intensities of the hybridization signals were measured by densitometry.

Table 1 shows the relative levels of cathepsin B mRNAs in five normal tissues and two cultured melanoma cells normalized to the levels of 18S rRNA. Compared to the spleen, which has the highest level of cathepsin B mRNA among the five normal tissues examined, the cathepsin B mRNA levels in A375P and A375M were 1.5 and 2.3 fold higher respectively.

B. Quantification of Variant Cathepsin B mRNAs by Northern Blot and RNase Protection Assay

Cathepsin B mRNAs are heterogeneous due to differences in processing of 5'- and 3'-ends of the pre-mRNA (Gong et al. 1993). The variable use of a cryptic 5' splice site in exon 11 with splicing to exon 12 causes the occasional loss of a polyadenylation signal in exon 11 and results in messages which differ by about 2 Kb in the lengths of their 3'-UTR. Variable removal of exon 2 produces messages which differ by 88 nt in their 5'-UTR. The discovery of multiple cathepsin B mRNAs generated by the alternative processing of the pre-mRNA opens up the possibility that it may be a mechanism for regulating cathepsin B expression in human tissues.

Table 1. Relative level of cathepsin B mRNA in human tissues and tumor cells

Normal Tissues	Ratio of density (CB/18s RNA)
Colon	0.01
Breast	0.21
Skeletal Muscle	0.15
Liver	0.18
Spleen	0.30
Kidney	0.25
Cultured Melanomas	
A375P, poorly metastatic	0.46
A375M, highly metastatic	0.68

To investigate alternative splicing of the 3'-UTR, Northern blot analysis was performed. Figure 11 is a representative blot which reveals the presence of the 2.3 Kb and 4.0 Kb transcripts in normal human skeletal muscle, kidney, liver, spleen and colon, and in the two human melanoma variants, A375P and A375M. Densitometric scan of the Northern blot (Table 2) revealed that the ratio of the 2.3 Kb transcript to the 4.0 Kb transcript only varied by about a factor 2, from 2.8 to 6.2. These differences do not appear large enough to be suggest that variant 3'-UTRs in cathepsin B mRNA have a regulatory significance.

An RNase protection assay was used to detect and quantify human cathepsin B mRNAs with differing 5'-ends. The riboprobe used is protected by the first 445 bases of mRNA containing the longer 5'-UTR (Figure 4). Based on the sequences of the two 5'-UTRs found in human cathepsin B cDNA (Chan *et al.* 1986; Gong *et al.* 1993), hybridization of this riboprobe with human cathepsin B transcripts should result in three protected fragments, a 445 nt fragment corresponding to mRNA containing the full length 5'-UTR, and 276 and 81 nt fragments corresponding mRNA lacking exon 2. These fragments were separated on a denaturing gel, and their sizes were estimated by comparing their mobilities with those of ϕ X174 RF DNA/*Hae*III molecular size markers. These three bands were seen in Figure 12. The densities of the 276 nt bands were much higher than those of 445 nt bands in all tumor cells

Table 2. Relative production of 2.3 Kb and 4.0 Kb cathepsin B mRNAs

Normal Tissue	4.0Kb/2.3Kb ratio*
Skeletal muscle	6.2
Kidney	2.8
Liver	4.1
Spleen	3.5
Colon	2.7
Cultured Tissues	4.0Kb/2.3Kb ratio*
A375P, post	3.1
A375M, high	6.0

*The signals of the 4.0 Kb and 2.3 Kb transcripts were measured by densitometry. The ratio of the signals of these two bands were calculated.

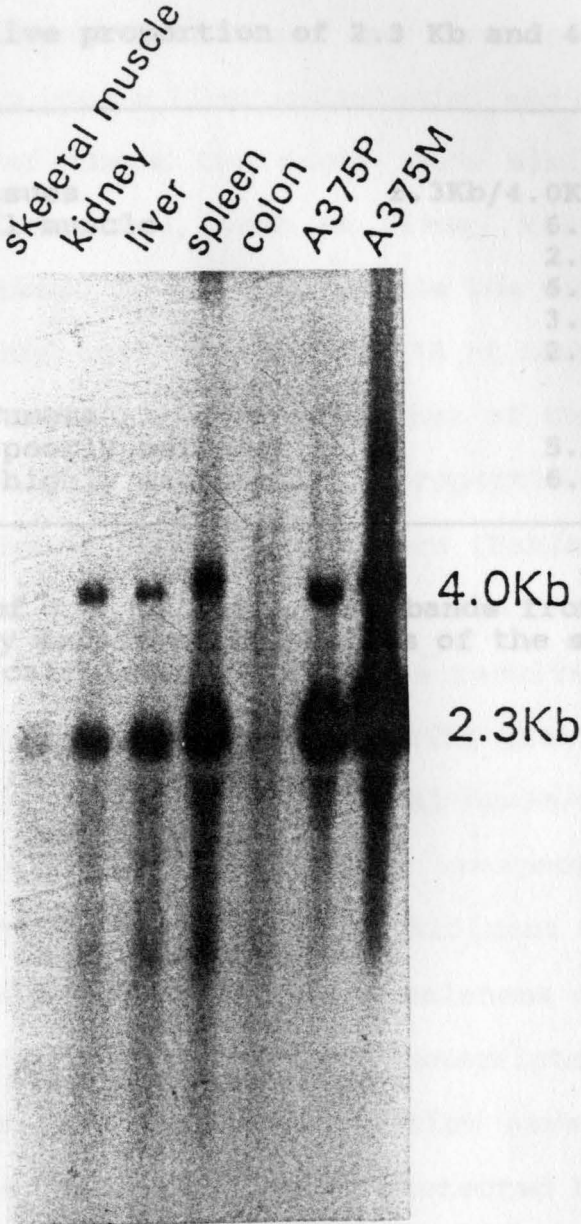

Figure 11. Northern blot of cathepsin B mRNA from human normal tissues and cultured melanoma cells. Total RNAs were isolated from normal human tissues, skeletal muscle, kidney, liver, spleen and colon, and two cultured human melanoma cells, A375P and A375M. 15 μ g of total RNA from each sample was denatured, electrophoresed on agarose gel and transferred onto Nytran filter, and the filter was hybridized with 32 P-labeled human cathepsin B cDNA. The presence of 2.3 Kb and 4.0 Kb transcripts are indicated.

Table 2. Relative proportion of 2.3 Kb and 4.0 Kb cathepsin B mRNAs

Normal Tissues	2.3Kb/4.0Kb ratio*
Skeletal muscle	6.2
Kidney	2.8
Liver	6.1
Spleen	3.5
Colon	2.7
Cultured Tumors	
A375P, poorly metastatic	5.1
A375M, highly metastatic	6.0

* The signals of 2.3 Kb and 4.0 Kb bands from Northern blot were measured by densitometry. Ratios of the signals of these two bands were calculated.

examined, including five cultured tumor cells, A375M, A375P, PC3M, PC3P and colon carcinoma, and three solid tumors, two colon carcinomas (one a liver metastasis) and a breast cancer. The densities of these two bands were similar in most of normal tissues examined, such as liver, kidney, breast and colon. In contrast, in skeletal muscle the density of the 445 nt band was higher than that of the 276 nt band. The ratio of the intensity of the 276 nt band to that of the 445 nt band is a measurement of the relative proportions of the two transcripts in human tissues and tumors (Table 3). The ratios varied from less than 0.1 to 3.2 for normal tissues, and from 6.0 to 20.1 for the tumors. From the results in Table 3, it can be seen that the transcripts lacking exon 2 are much more abundant in human tumors than in normal human tissues. Figure 12 also reveals the presence of an unexpected fragment of about 140 nt which was found in significant amount in three solid tumors and two cultured human melanoma cells, A375M and A375P. This fragment arises from transcripts lacking exon 3 (see below). When the RNase protection assay was performed with probe alone (without RNA), no protected bands were seen. When the RNase protection assay was performed without RNase digestion, only the 445 base fragment was seen (Figure 13).

C. Amplification of the 5'-Ends of Cathepsin B cDNA from Human Normal Tissues and Tumors by PCR

RNase protection studies revealed a fourth major protected band (140 +/- 10 bases) with mRNAs from human breast

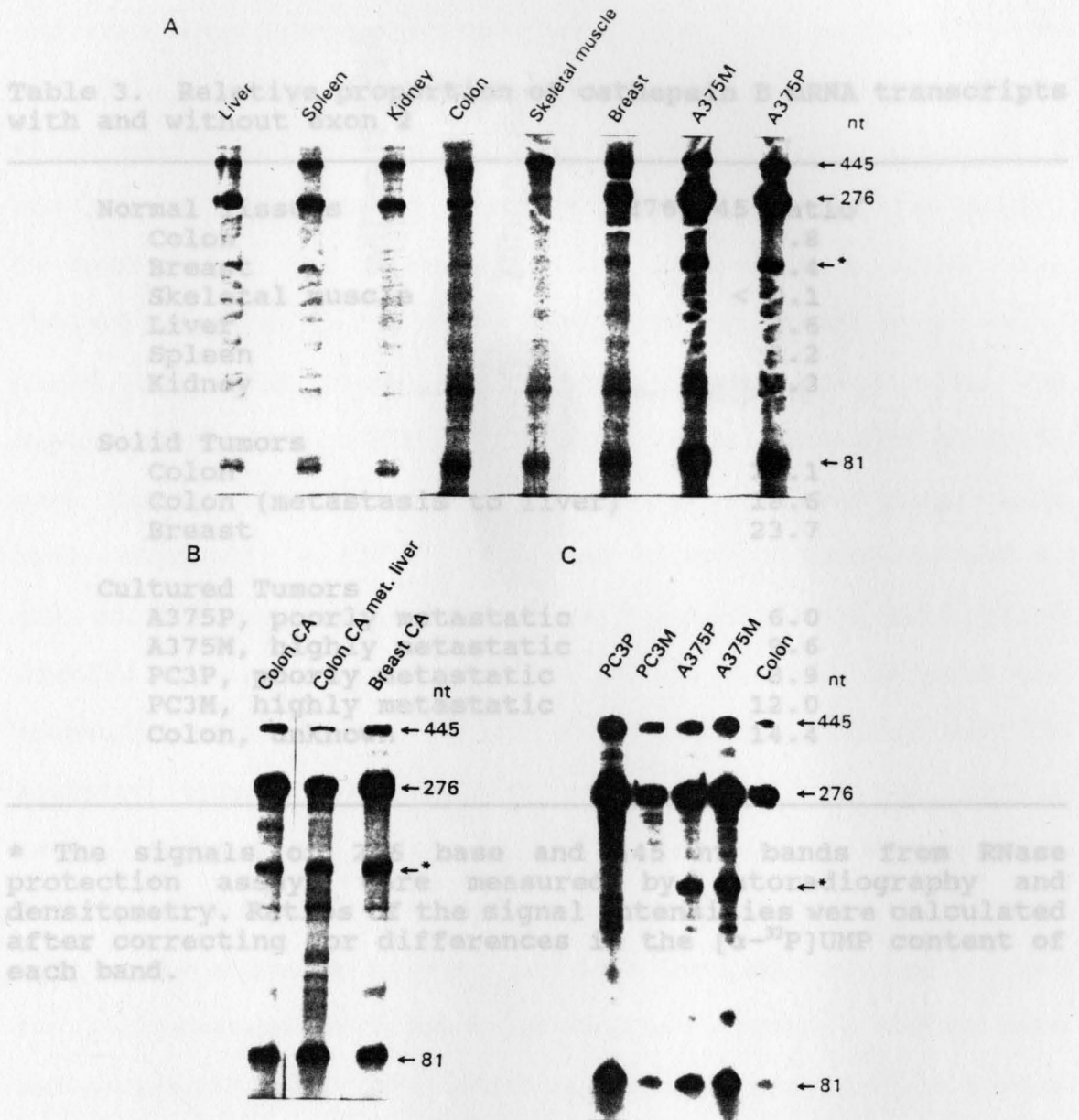

Figure 12. RNase protection of variant 5'-ends of human cathepsin B mRNAs. After hybridization to total RNA, the 445 nt riboprobe is completely protected from RNase digestion by transcripts which contain the complete 5'-UTR. Transcript lacking exon 2 produce 276 and 81 nt fragments. Panel A, RNA from normal tissues and two cultured melanoma cell lines. Panel B, RNA from three different human tumors, two colon carcinomas (one a liver metastasis) and breast cancer. Panel C, RNA from cultured human tumor cells. RNA from some human tumors give rise to a fourth prominent band (*) which appears to be about 140 nt in length. This fragment arises from transcript missing exons 2 and 3.

Table 3. Relative proportion of cathepsin B mRNA transcripts with and without exon 2

Normal Tissues	276/445 ratio*
Colon	0.8
Breast	2.4
Skeletal muscle	< 0.1
Liver	2.6
Spleen	3.2
Kidney	2.3
 Solid Tumors	
Colon	20.1
Colon (metastasis to liver)	18.6
Breast	23.7
 Cultured Tumors	
A375P, poorly metastatic	6.0
A375M, highly metastatic	9.6
PC3P, poorly metastatic	8.9
PC3M, highly metastatic	12.0
Colon, unknown	14.4

* The signals of 276 base and 445 nt bands from RNase protection assays were measured by autoradiography and densitometry. Ratios of the signal intensities were calculated after correcting for differences in the [α - 32 P]UMP content of each band.

and colon carcinomas and human melanomas. One possibility was that this fragment originates from a cathepsin B transcript in which exon 1 was spliced directly to exon 4, deleting exons 2 and 3 (125 base fragment expected in RNase protection assay). To test this, the 5'-ends of the cathepsin B mRNAs from skeletal muscle, solid colon carcinoma, cultured tumor cells A375M and PC3M were reverse transcribed into cDNA and amplified by PCR. After electrophoresis, the PCR products were transferred onto a nylon filter and hybridized with human cathepsin B cDNA. Northern hybridization revealed 549 bp and 461 bp fragments which were derived from cDNAs which contain or lack exon 2 (Figure 14). The 461 bp band was predominant with RNA from the solid colon carcinoma and the cultured tumor cells, A375M and PC3M, but was barely detectable with RNA from muscle. These results confirmed the findings obtained with the RNase protection assay. The 306 bp band is the expected product for cDNA lacking both exons 2 and 3. In agreement with RNase protection studies, 306 bp band was seen with A375M and solid colon carcinoma, but not with skeletal muscle and PC3M.

Figure 13. Evaluation of the riboprobe used in the RNase protection assay. RNase protection assay was performed with probe alone (without RNA), no protected bands were seen. RNase protection assay was performed without RNase digestion, only 445 nt fragment was seen (Riboprobe).

In order to characterize the transcript lacking exons 2 and 3, a cDNA corresponding to this transcript was cloned by reverse transcription PCR. Total RNA isolated from A375M cells was reverse transcribed and the single stranded cDNA was amplified by PCR.

without RNA

Riboprobe



← 445 nt

and colon carcinomas and human melanomas. One possibility was that this fragment originated from a cathepsin B transcript in which exon 1 was spliced directly to exon 4, deleting exons 2 and 3 (125 base fragment expected in RNase protection assay). To test this, the 5'-ends of the cathepsin B mRNAs from skeletal muscle, solid colon carcinoma, cultured tumor cells A375M and PC3M were reverse transcribed into cDNA and amplified by PCR. After electrophoresis, the PCR products were transferred onto a Nytran filter and hybridized with human cathepsin B cDNA. This hybridization revealed 549 bp and 461 bp fragments which were derived from cDNAs which contain or lack exon 2 (Figure 14). The 461 bp band was predominant with RNA from the solid colon carcinoma and the cultured tumor cells, A375M and PC3PM, but was barely detectable with RNA from muscle. These results confirmed the findings obtained with the RNase protection assay. The 306 bp band is the expected product for cDNA lacking both exons 2 and 3. In agreement with RNase protection studies, 306 bp band was seen with A375M and solid colon carcinoma, but not with skeletal muscle and PC3M.

D. Molecular Cloning of Human Cathepsin B cDNA Lacking Exons 2 and 3

In order to characterize the transcript lacking exons 2 and 3, a cDNA corresponding to this transcript was cloned by PCR. Total RNA isolated from A375M cells was reverse transcribed and the single stranded cDNA was amplified by PCR.

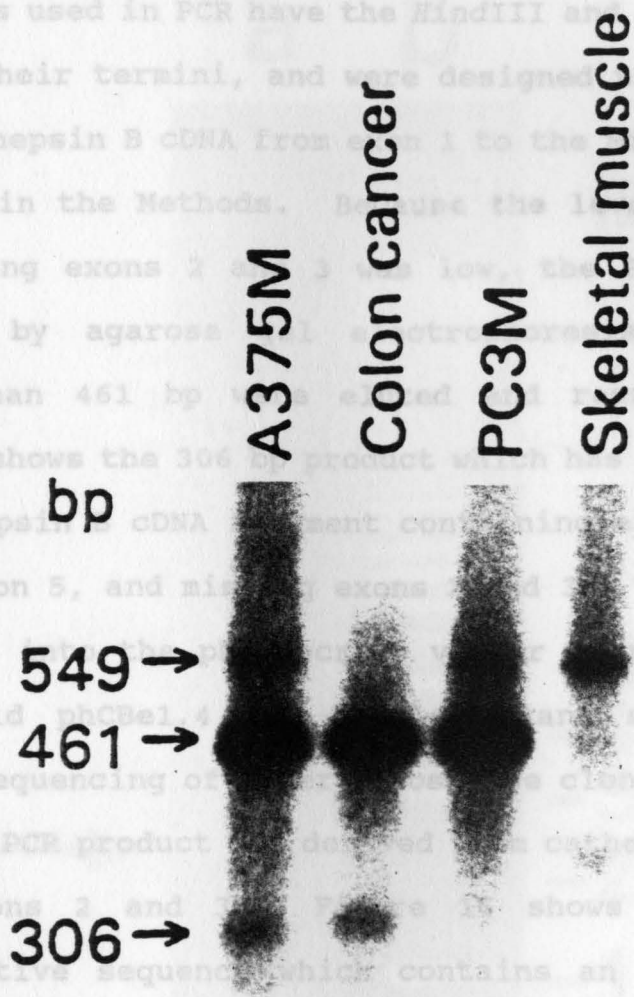

Figure 14. PCR amplification of the 5'-ends of cathepsin B cDNA from human normal tissues and tumors. This figure shows a Southern blot of products obtained after reverse transcription and PCR amplification of the 5'-ends of cathepsin B cDNA from two human tumor cell lines, A375M (melanoma) and PC3P (prostate carcinoma), a solid colon carcinoma, and normal skeletal muscle. The pair of primers used for the PCR were complementary to regions in exon 1 and exon 5. The 549 and 461 bp bands are from cDNAs which contain and lack exon 2 respectively. The 306 bp fragment is the expected product of cDNA which lacks both exons 2 and 3. The 306 bp band was only seen with cDNAs from tissues which yielded detectable levels of the 140 nt band in RNase protection studies (Figure 12).

B 5' cDNA fragment which is missing exon 2, noncoding, and

The primers used in PCR have the *Hind*III and *Eco*RI restriction sites at their termini, and were designed to amplify the 5'-end of cathepsin B cDNA from exon 1 to the middle of exon 5 as described in the Methods. Because the level of cathepsin B cDNA missing exons 2 and 3 was low, the PCR products were separated by agarose gel electrophoresis, and fragments smaller than 461 bp were eluted and reamplified by PCR. Figure 15 shows the 306 bp product which has the expected size of a cathepsin B cDNA fragment containing exon 1, exon 4 and part of exon 5, and missing exons 2 and 3. This PCR fragment was cloned into the pBluescript vector (Stratagene) to make the plasmid pHCBel.4 for single strand sequencing. The complete sequencing of several positive clones confirmed that the 306 bp PCR product was derived from cathepsin B mRNA which lacked exons 2 and 3. Figure 16 shows a portion of a representative sequence which contains an exon 1 - exon 4 junction. In order to further characterize the transcript lacking exons 2 and 3, a fragment from pHCBel.4, containing part of exon 1 and part of exon 4, was cloned into pHCB79-2 to replace the corresponding region containing exons 2 and 3. The resulting plasmid, pHCB79-2-2.3, harbored a cathepsin B cDNA lacking exons 2 and 3 as described in Methods (Figure 8).

E. Detection of Cathepsin B mRNA That Is Missing Exons 2 and 3 by PCR

Total RNA from tumor cells was used to clone a cathepsin B 5' cDNA fragment which is missing exon 2, noncoding, and

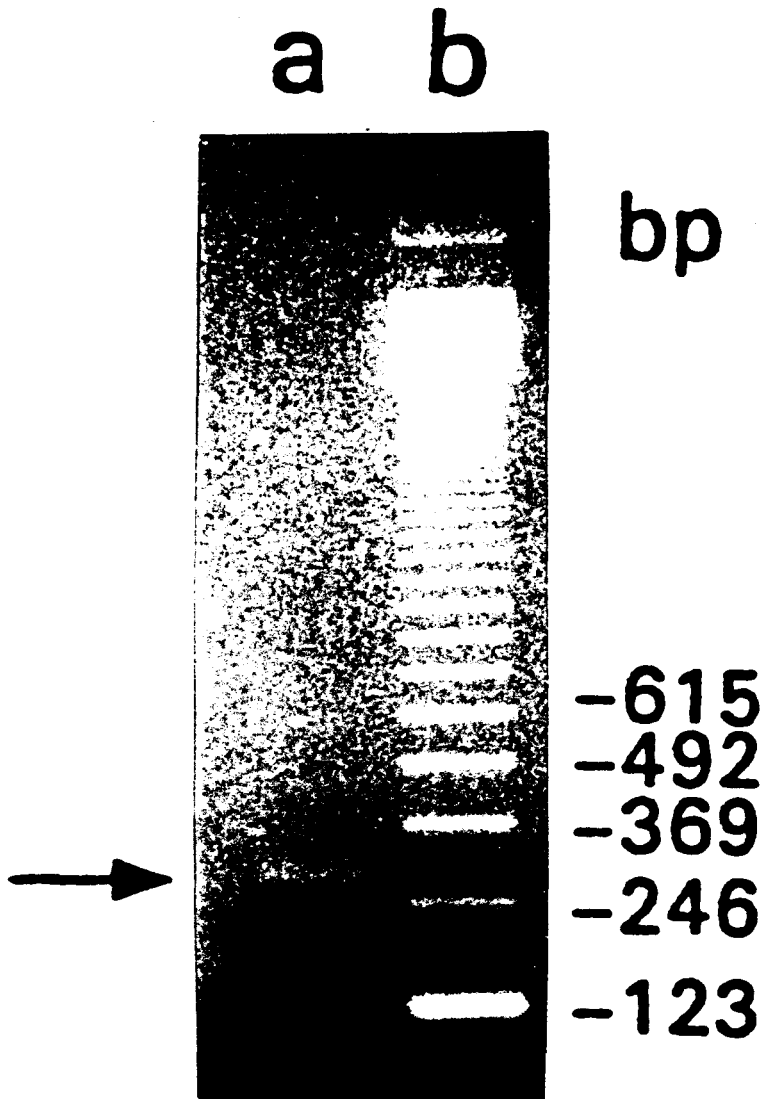

Figure 15. PCR amplification of 5'-end of cathepsin B cDNA missing exons 2 and 3. 5'-ends of cathepsin B cDNAs were amplified from A375M cells as described in Figure 15. Products smaller than 461 bp were isolated by agarose gel electrophoresis and used as templates for reamplification by PCR. A 306 bp fragment (indicated by arrow) was obtained, which is expected product of cathepsin B cDNA missing exons 2 and 3.

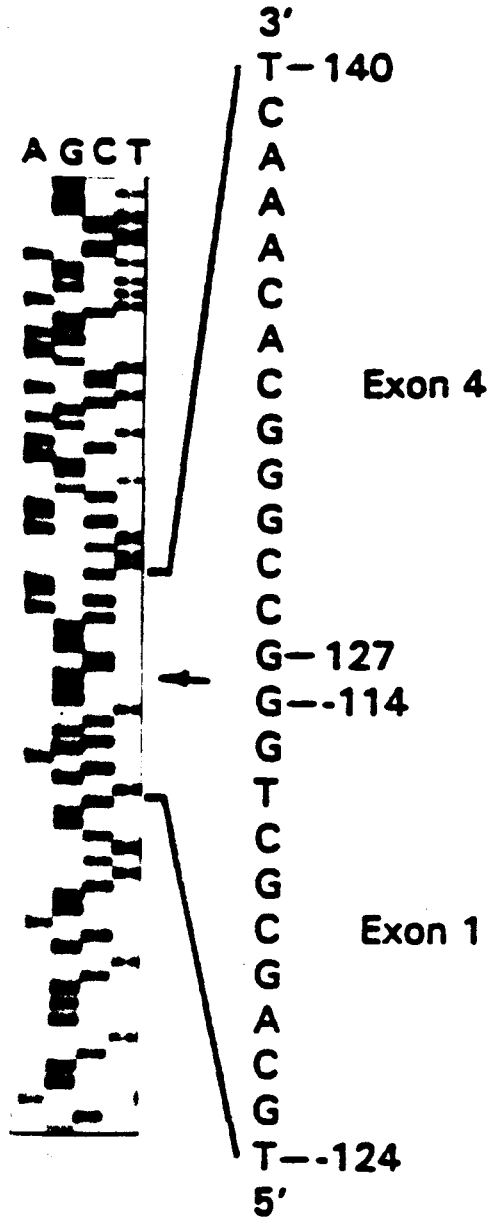

Figure 16. Sequence of the 306 bp PCR product amplified from cathepsin B cDNA in A375M cells. The 306 bp PCR product, obtained as described in Figure 15, was cloned into *EcoRI* and *HindIII* sites of pBluescript vector, and sequenced. The complete sequence of several positive clones revealed that they arose from cathepsin B transcript which lacked exons 2 and 3. A portion of a representative sequence corresponding to the exon 1 - exon 4 junction is shown.

exon 3, encoding the signal prepeptide and part of the activation propeptide. Reverse transcription and PCR amplification was next used to confirm that human tumors contain a corresponding mRNA which contains the remainder of the procathepsin B coding sequence and the 3'-UTR present in other cathepsin B messages (Figure 17). For the amplification, the 5' primer (sense primer) was complementary to 9 nucleotides on each side of the exon 1 - exon 4 junction, and the 3' primer (antisense primer) was complementary to a 20 nucleotide sequence present in the flanking 3' untranslated region of all known, full length cathepsin B mRNAs (Chan et al. 1986). cDNA templates prepared from PC3M cell RNA, and the plasmids pHCB79-2 and pHCB79-2-2.3, were included to verify the specificity of the sense primer for the exon 1-exon 4 junction. Previous RNase protection studies were unable to detect any cathepsin B transcripts in PC3M that were missing exon 3; plasmid pHCB79-2 harbors a full length cathepsin B cDNA, including the complete 3'-UTR of the 2.3 kb human cathepsin B mRNA; and plasmid pHCB79-2-2.3 is identical to pHCB79-2 except it is missing exons 2 and 3. The 934 bp PCR product, obtained with pHCB79-2-2.3 as a template, is indistinguishable in size from the PCR products obtained with the cDNAs from the two human melanomas variants, A375M and A375P. The identity of the PCR products which were amplified from cathepsin B cDNA was confirmed by hybridization with human cathepsin B cDNA.

7. In Vitro Translation of Variant Cathepsin B mRNA

RNAse protection assays have shown striking differences in the relative abundances of cathepsin B mRNAs which differ in their 5'-ends in normal human tissues and in human tumors.

Exon 2, which is more frequently absent from the 5'-UTR of cathepsin B mRNAs from human tumors, has features which can affect the translational efficiency of the mRNA.

The length of the 5'-UTR contains adjacent start sites and codons which may affect the potential for alternative start sites and compute the potential for alternative start sites.

secondarily a region of exon 2 and a nearby downstream start site. The cathepsin B mRNAs which differ in their 5'-UTRs may differ in their ability to direct protein synthesis.

been found in colon and breast carcinomas. Since exon 3 contains the translation start site,

Figure 17. Detection of cathepsin B mRNA that lacks exons 2 and 3 by PCR. Total RNA was reverse transcribed and cDNA amplified by PCR. Plasmid DNA was amplified directly after linearization with *Xba*I. The sense primer was directed against the exon 1 - exon 4 junction and the antisense primer was directed against a 3' untranslated sequence present in all full length cathepsin B mRNAs. Lane M, molecular size marker prepared by digestion of lambda phage with *Eco*RI and *Hind*III; PC3M, human prostate carcinoma; A375M, human melanoma (metastatic); A375P, human melanoma (parental, poorly metastatic); phCB79-2, harbors a cDNA clone containing all 11 exons of cathepsin B including the 798 nucleotide 3'-UTR; phCB79-2-2.3, identical to phCB79-2, except missing exons 2 and 3. Panel A, after electrophoresis of PCR products on a 0.7% agarose gel and staining with ethidium bromide. Panel B, after transfer of the PCR products to a Nytran filter, hybridization to human cathepsin B cDNA and autoradiography.

translation system was used as described in Methods.

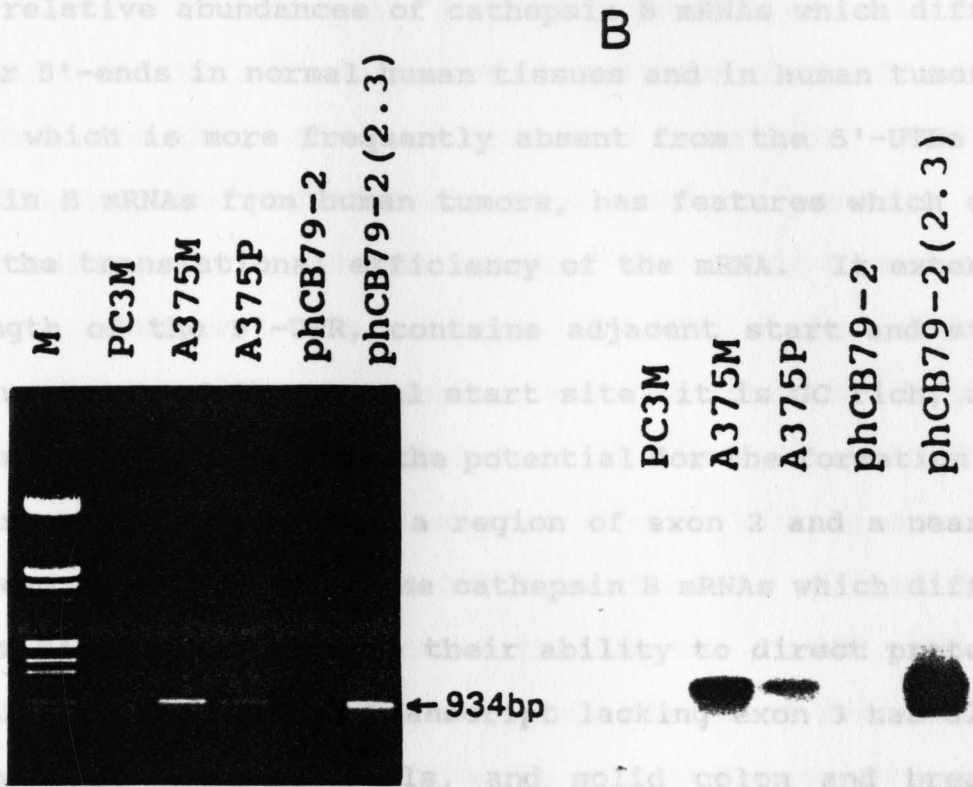

F. In Vitro Translation of Variant Cathepsin B mRNA

RNase protection assays have shown striking differences in the relative abundances of cathepsin B mRNAs which differ in their 5'-ends in normal human tissues and in human tumors. Exon 2, which is more frequently absent from the 5'-UTRs of cathepsin B mRNAs from human tumors, has features which can affect the translational efficiency of the mRNA. It extends the length of the 5'-UTR, contains adjacent start and stop codons upstream of the normal start site, it is GC rich, and computer analysis indicates the potential for the formation of secondary structure between a region of exon 2 and a nearby downstream sequence. Thus the cathepsin B mRNAs which differ in their 5'-UTRs may vary in their ability to direct protein synthesis. A cathepsin B transcript lacking exon 3 has also been found in melanoma cells, and solid colon and breast carcinomas. Since exon 3 contains the translation start site, and encodes the signal prepeptide and 7 residues of propeptide, it was unclear whether such transcripts containing an exon 1 - exon 4 splice junction would be translationally active. However, there is an in-frame methionine codon, corresponding to amino acid 52 in preprocathepsin B, which potentially could be used for translation initiation. To determine the translational activities and translatability of the various human cathepsin B mRNAs which differ in their exon composition, an *in vitro* transcription and reticulocyte lysate translation system was used as described in Methods.

The SP6 promoter in pGEM-2 vector has been used to generate specific transcripts with biological activity (Melton et al. 1984). Cathepsin B cDNAs with different exon composition in their 5'-ends were cloned into the *EcoRI* site, adjacent to the SP6 promoter as described in Methods. phCB79-2, phCB79-2-2 and phCB79-2-2.3 were used to generate the corresponding cathepsin B mRNA species. Cathepsin B mRNA from phCB79-2 contains the longer 5'-UTR, the entire preprocathepsin coding sequence, and the shorter 3'-UTR. Cathepsin B mRNA from phCB79-2-2 is the same as that from phCB79-2 except that it has shorter 5'-UTR lacking exon 2. Cathepsin B mRNA from phCB79-2-2.3 is the same as that from phCB79-2 except that it contains the shorter 5'-UTR, and is also missing exon 3 encoding the prepeptide and 25 residues of the propeptide. Translation from the next in-frame methionine codon should produce a protein lacking the signal peptide and 34 of the 62 residue propeptide. Capped mRNAs transcribed *in vitro* were examined by electrophoresis on an agarose gel, transferred onto a Nytran filter, and the filter was hybridized with human cathepsin B cDNA. The autoradiogram in Figure 18 shows that essentially all of the transcripts were full length and of the expected size. Phenol/chloroform extraction and ethanol precipitation did not cause the degradation and loss of the transcripts. These transcripts were used for *in vitro* translation in the reticulocyte lysate in the presence of ³⁵S-methionine.

Translation activities were determined by varying both RNA template concentration and incubation time for the translocation reaction. The results are expressed here as the rate of labeled methionine incorporation at various template concentration and as the specific activity of the template (incorporated ³⁵S-methionine labeled protein was precipitated with trichloroacetic acid, and radioactivity measured. Figure 19 shows the translational activities of cathepsin B mRNAs with or without exon 2 with respect to amount of RNA and time of incubation. From this figure it can be seen that cathepsin B mRNA with the shorter 5'-UTR, the major isoform from tumors (phCB79-2-2) is about twice as active as the mRNA with the longer 5'-UTR, the major isoform on normal tissues (phCB79-2). ³⁵S-methionine labeled protein was also analyzed by SDS electrophoresis and autoradiography. The protein yield from cathepsin B mRNA with the shorter 5'-UTR (phCB79-2-2) was

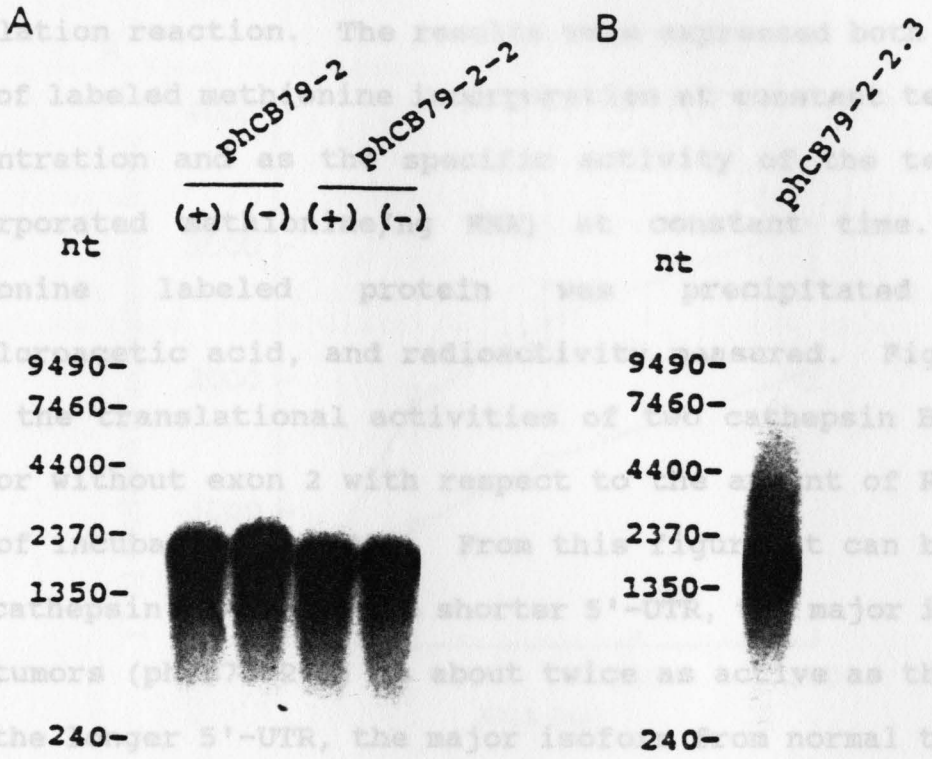

Figure 18. Analysis of SP6 directed variant cathepsin B transcripts. The capped variant cathepsin B mRNAs were synthesized as described under the Methods. Before (-) or after (+) phenol/chloroform extraction and ethanol precipitation, 0.5 μg of the synthetic RNA was denatured with formamide/formaldehyde, electrophoresed in a 1.1% agarose /0.02% formaldehyde gel and transferred onto a Nytran filter. The filter was hybridized with ³²P-labeled human cathepsin B cDNA. Panel A: phCB79-2, RNA transcribed from phCB79-2 which harbors a cDNA clone containing all 11 exons of cathepsin B including the shorter 3'-UTR; phCB79-2-2, RNA transcribed from phCB79-2-2 which is missing exon 2. Panel B: phCB79-2-2.3, RNA was transcribed from phCB79-2-2.3, which is missing exons 2 and 3, and was extracted with phenol/chloroform.

In order to study the translation potential of cathepsin B mRNA lacking exon 3, the synthetic RNA missing exon 2 and

Translation activities were determined by varying both RNA template concentration and incubation time for the translation reaction. The results were expressed both as the rate of labeled methionine incorporation at constant template concentration and as the specific activity of the template (incorporated methionine/ng RNA) at constant time. ³⁵S-methionine labeled protein was precipitated with trichloroacetic acid, and radioactivity measured. Figure 19 shows the translational activities of two cathepsin B mRNAs with or without exon 2 with respect to the amount of RNA and time of incubation at 30°C. From this figure it can be seen that cathepsin mRNA with the shorter 5'-UTR, the major isoform from tumors (phCB79-2-2) is about twice as active as the mRNA with the longer 5'-UTR, the major isoform from normal tissues (phCB79-2). ³⁵S-methionine labeled protein was also analyzed by SDS electrophoresis and autoradiography. The protein yield from cathepsin B mRNA with the shorter 5'-UTR (phCB79-2-2) was higher than that from the mRNA with the longer 5'-UTR (phCB79-2) (Figure 20). Figure 20 also shows a single major band of the size expected (approx 37 kDa) for nonglycosylated form of preprocathepsin B (339 amino acids) (Chan et al. 1986). The results showed in Panel B were same as those in Panel A, except varying amount of RNA template was used, and the incubation time was 1 hour.

In order to study the translation potential of cathepsin B mRNA lacking exon 3, the synthetic RNA missing exon 2 and

Figure 19. Rates of *in vitro* translation of synthetic cathepsin B mRNAs containing variant 5'-UTR

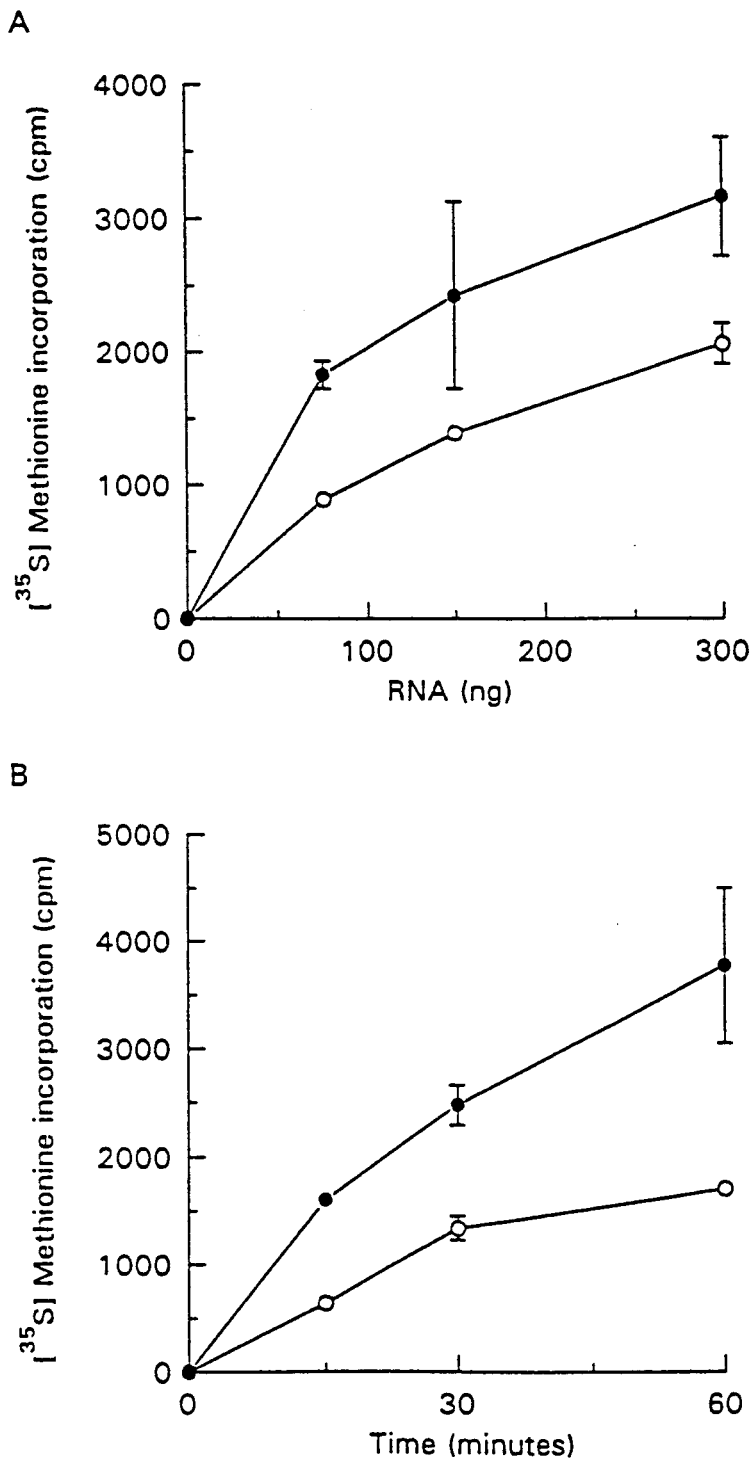
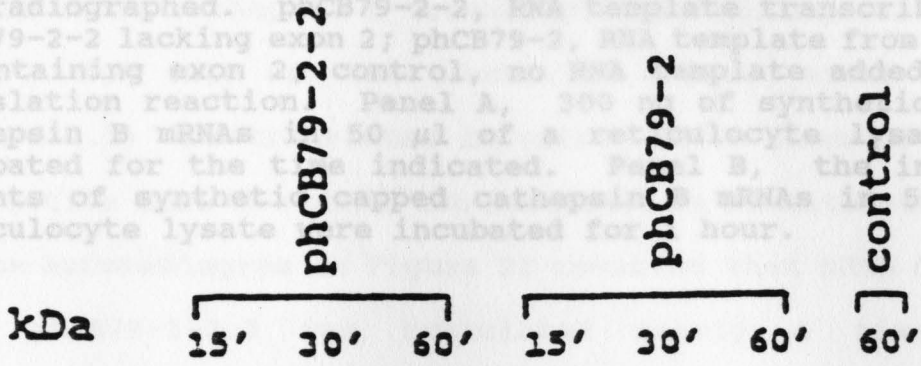

Figure 19. Rates of *in vitro* translation of synthetic cathepsin B mRNAs containing variant 5'-UTRs. Panel A, the specific activities of the two variant templates were determined by incubating reticulocyte lysates for 60 min with the indicated concentrations of capped cathepsin B synthetic RNAs as described in Methods. The amount of [³⁵S]L-methionine incorporated into trichloroacetic acid-insoluble products was measured with a liquid scintillation spectrometer. Panel B, the effect of time on [³⁵S]L-methionine incorporation into trichloroacetic acid-insoluble products was measured as described for panel A using 300 ng of template in a final volume of 50 μ l. Closed circles, mRNA template used in the translation was transcribed from clone phCB79-2-2 lacking exon 2; open circles, from clone phCB79-2 containing exon 2.

Fig 20. SDS-PAGE electrophoresis analysis of *in vitro* translation products from cathepsin B mRNAs with and without exon 2.

Synthetic capped cathepsin B mRNAs were incubated with a reticulocyte lysate at 30°C as indicated. Five µl of the *in vitro* translation reaction mixture were then electrophoresed on a 10% polyacrylamide-SDS gel and autoradiographed. phCB79-2-2, RNA template transcribed from phCB79-2-2 lacking exon 2; phCB79-2, RNA template from phCB79-2 containing exon 2; control, no RNA template added to the translation reaction. Panel A, 300 µg of synthetic capped cathepsin B mRNAs; 50 µl of a reticulocyte lysate were incubated for the times indicated. Panel B, the indicated amounts of synthetic capped cathepsin B mRNAs; 50 µl of reticulocyte lysate were incubated for 1 hour.

A



B

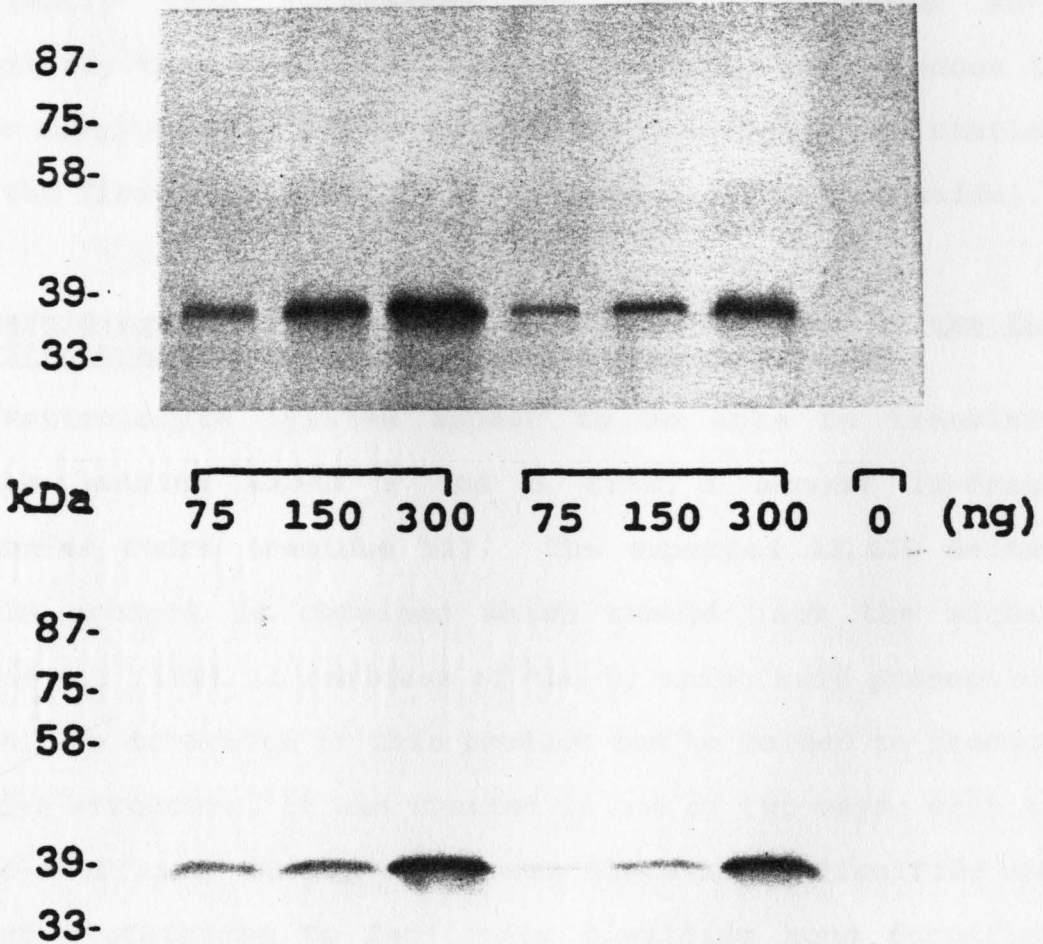

Figure 20. SDS-PAGE electrophoresis analysis of *in vitro* translation products from cathepsin B mRNAs with and without exon 2. Synthetic capped cathepsin B mRNAs were incubated with a reticulocyte lysate at 30°C as indicated. Five μ l of the *in vitro* translation reaction mixture were then electrophoresed on a 10% polyacrylamide-SDS gel and autoradiographed. phCB79-2-2, RNA template transcribed from phCB79-2-2 lacking exon 2; phCB79-2, RNA template from phCB79-2 containing exon 2; control, no RNA template added to the translation reaction. Panel A, 300 ng of synthetic capped cathepsin B mRNAs in 50 μ l of a reticulocyte lysate were incubated for the time indicated. Panel B, the indicated amounts of synthetic capped cathepsin B mRNAs in 50 μ l of reticulocyte lysate were incubated for 1 hour.

3 from phCB79-2-2.3 was also translated *in vitro* in reticulocyte lysate, and analyzed by SDS-electrophoresis and autoradiography. Figure 21 compares the translation products of all three cathepsin B transcripts containing variant 5'-ends. Not only can the transcript missing exons 2 and 3 (phCB-2-2.3) be translated *in vitro*, it is seen to be much more active than the other two isoforms. A densitometric scan of the autoradiogram in Figure 21 revealed that mRNA obtained from phCB79-2-2.3 was translated nearly 4 times more efficiently than phCB79-2-2 and nearly 8 times more efficiently than phCB79-2. Second, the resulting product is of the expected size (about 32 KDa) for translation initiation from the first methionine codon in exon 4 (288 amino acids).

G. Refolding of a Truncated Cathepsin B Produced by the *In vitro* Translation of mRNA Lacking Exons 2 and 3

Reticulocyte lysates appear to be able to translate message lacking exons 2 and 3 from a second in-frame methionine codon (residue 52). The expected 32,000 dalton protein product is obtained which should lack the signal peptide and first 34 residues of the 62 amino acid propeptide region. To determine if this product can be folded to produce a native structure, it was treated in one of two ways: with an "oxido-shuffling" buffer containing glutathione disulfide and reduced glutathione to facilitate disulfide bond formation (Jaenicke and Rudolph, 1989); and with decreasing concentration of guanidinium hydrochloride as described in

Methods (Hager and Burgess, 1980; Vinson et al. 1988). The ability to acquire enzymatic activity is a highly stringent test of protein folding into a native conformation. The results in Figure 22 demonstrate that the missing propeptide region of the 32,000 dalton protein product is not essential for correct folding and acquisition of enzymatic activity. *In vitro* translation reactions which lacked the synthetic mRNA templates have no activity under any of the refolding conditions tried.

No schematic was made of the conditions necessary to optimize the refolding of the 32,000 dalton translation product. The recovery of activity, obtained by dialysis into concentrations of guanidinium hydrochloride of 0.5 M for 30 minutes, is still likely to be a low percentage of the constants reported for 2-Arg-Arg-NMe₂ propeptide of cathepsin B (Tchoupe et al. 1991), and the amount of ³⁵S-methionine incorporated into TCA precipitable products, we estimate that as much as 2% of the synthetic truncated protein may have acquired a native

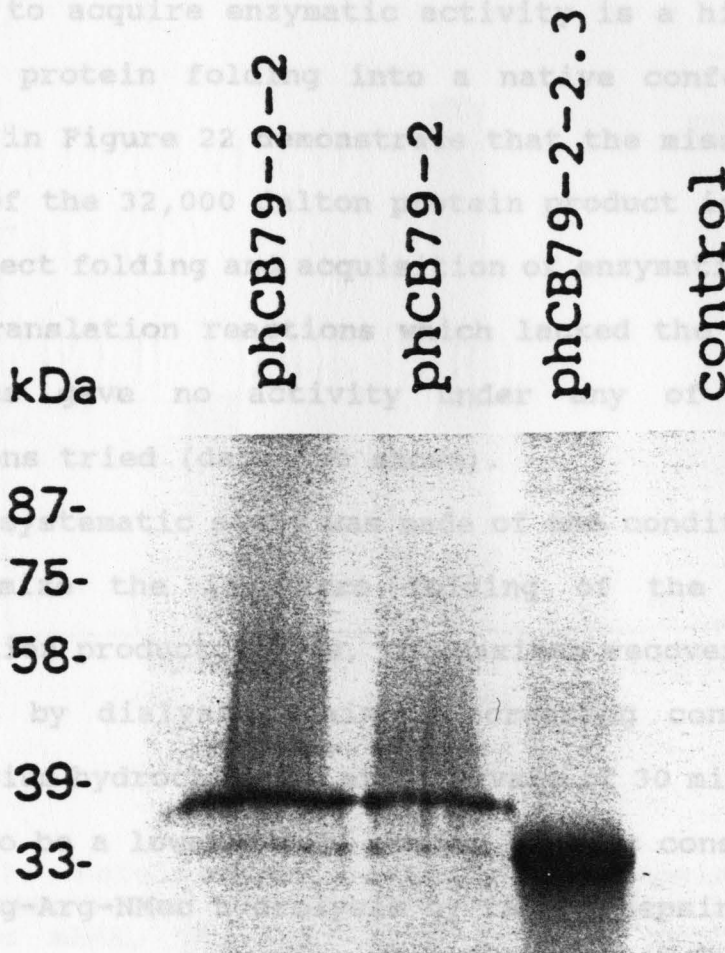

Figure 21. *In vitro* translation of synthetic cathepsin B mRNAs with variant 5'-ends. 300 ng of synthetic capped cathepsin B mRNAs containing variant 5'-ends in 50 μ l of a reticulocyte lysate were incubated for 1 hour at 30°C. Two μ l of the mixture from each sample were electrophoresed on a 10% polyacrylamide-SDS gel and autoradiographed. phCB79-2-2, the RNA template transcribed from phCB79-2-2 lacking exon 2; phCB79-2, the RNA template from phCB79-2 containing exon 2; phCB79-2-2.3, the RNA template from phCB79-2-2.3 lacking exons 2 and 3; control, no RNA template added to the translation reaction.

activation propeptide is not needed for activation, or some of the enzymes underwent autolysis during folding which removed

Methods (Hager and Burgess, 1980; Vinson *et al.* 1988). The ability to acquire enzymatic activity is a highly stringent test of protein folding into a native conformation. The results in Figure 22 demonstrate that the missing propeptide region of the 32,000 dalton protein product is not essential for correct folding and acquisition of enzymatic activity. *In vitro* translation reactions which lacked the synthetic mRNA templates gave no activity under any of the refolding conditions tried (data not shown).

No systematic study was made of the conditions necessary to optimize the *in vitro* folding of the 32,000 dalton translation product. Thus, the maximum recovery of activity, obtained by dialysis against decreasing concentrations of guanidinium hydrochloride at intervals of 30 minutes, is still likely to be a lower limit. Using kinetic constants reported for Z-Arg-Arg-NMec hydrolysis by rat cathepsin B (Tchoupe *et al.* 1991), and the amount of ³⁵S-methionine incorporated into TCA precipitable products, we estimate that as much as 2% of the synthetic truncated protein may have acquired a native structure. This level was easily measured by the standard cathepsin B assay. Also noteworthy is our finding that the guanidinium hydrochloride treated product was active (33%) prior to treatment with pepsin to remove the remainder of the activation propeptide. Either the loss of the entire activation propeptide is not needed for activation, or some of the enzyme underwent autolysis during folding which removed

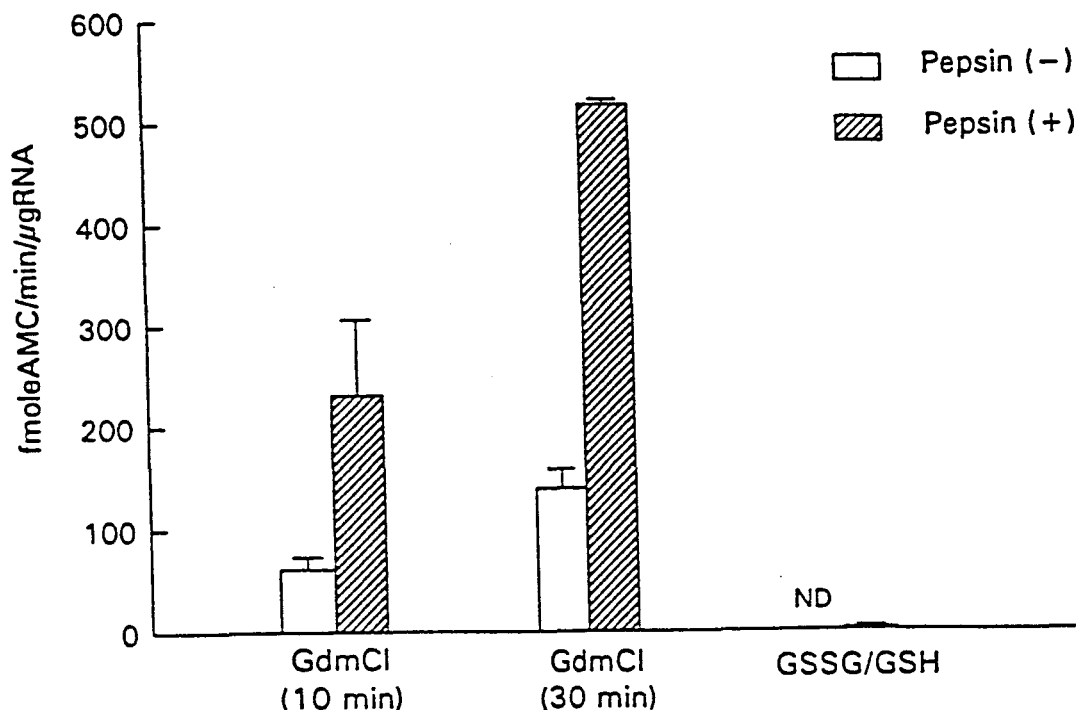

Figure 22. Refolding of a truncated cathepsin B produced by the *in vitro* translation of mRNA missing exon 2 and 3. Capped synthetic mRNA, prepared with plasmid pHCB79-2-2.3 as a template, was translated by a reticulocyte lysate as described in Methods. Refolding was initiated by sequential dialysis against decreasing concentrations of guanidinium hydrochloride with buffer changes at 10 or 30 min intervals, or by treatment with a glutathione disulfide/reduced glutathione "oxido-shuffling" buffer. Enzymatic activity is expressed as fmol of 7-amino-4-methylcoumarin (AMC) released from Z-Arg-Arg-NMec per min per μg of synthetic mRNA translated. Activity was measured before and after treatment with pepsin to remove the remainder of amino-terminal propeptide. No activity was observed when synthetic mRNA was withheld from the translation reaction.

the remainder of the propeptide. The "oxido-shuffling" treatment of the *in vitro* translated product did not yield an active enzyme species.

CHAPTER V

DISCUSSION

A. Multiple Forms of Cathepsin B Transcripts in Human Tissues

Cathepsin B cDNA cloned from normal human kidney and the hepatoma cell line, HepG2, are heterogeneous (Chan *et al.* 1986; Gong *et al.* 1993). Northern blotting revealed the presence of 2.3 and 4.0 Kb transcripts (Figure 11). Analysis of the cloned cDNAs from both sources has further identified four cathepsin B transcript types as shown in Figure 23. In this present work, I have also identified a fifth type which is present in some human tumors, by using a combination of PCR and RNase protection assays. Transcript type 1 (4.0 Kb) contains a 237 nt 5' untranslated region (5'-UTR), 1017 nt encoding preprocathepsin B, and about a 2800 nt 3'-UTR, while type 2 is identical to type 1 except for the deletion of an 88 nt segment in the 5'-UTR (Figure 23). Transcript types 3 and 4 (2.3 Kb) contain a 789 nt 3'-UTR. The types 3 and 4 differ in that type 4 has the same 88 nt deletion in the 5'-UTR found in the type 2 transcript. The transcript type 5 has the 88 nt deletion which is found in the transcripts type 2 and 4, and also has an additional 151 nt deletion corresponding to

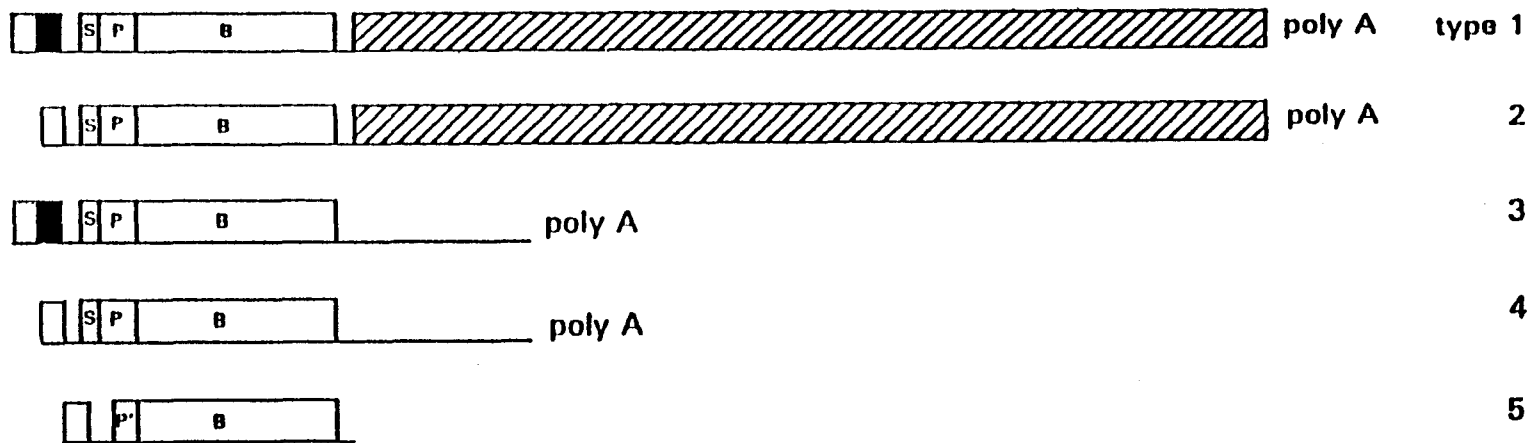

Figure 23. Variant cathepsin B transcripts in human tissues. Overlapping cDNA clones corresponding to types 1, 2, 3, and 4 were isolated from human kidney and HepG2 phage libraries. The type 5 transcript was cloned from human melanoma cells and characterized by PCR as described in the text. The small open box indicates the exon 1. The solid box indicates the 88 nt 5' untranslated segment which was deleted in transcript types 2, 4, and 5. The type 5 transcript also has an additional 151 nt deletion corresponding to the signal peptide (S) and 7 amino acid residues of the propeptide (P). The hatched box indicates the alternative 3' untranslated region. The part of the 3' untranslated region in the transcript types 1 through 5, which is common to all full length cathepsin B mRNAs, is also shown. The remainder of the 3' untranslated region in the type 5 transcript has not been characterized.

the signal peptide and 25 amino acid residues of the propeptide. The 3'-UTR of the type 5 transcript has not yet been identified. The preprocathepsin B coding sequence was identical in all transcripts except for type 5 which lacked the exon encoding signal peptide and 25 residues of the propeptide.

Cloning and sequencing the human cathepsin B gene demonstrated that the multiple cathepsin B transcripts were derived from alternative processing of the pre-mRNA (Gong et al. 1993). Figure 24 shows the organization of the human cathepsin B gene. Phage λ hCB107 contained a 11,500 bp insert which included the first two exons, which corresponded to the 5' untranslated sequences. Phage λ hCB102 contained a 13,500 bp insert which included the entire coding sequence of preprocathepsin B divided into 9 exons numbered 3-11, and contained alternative 3'-UTRs located in exon 11 and exon 12. Thus, RNA processing at a cryptic intron donor site located in exon 11 and splicing to exon 12 deleted the first polyadenylation signal and generated the longer alternative 3'-UTR found in transcript types 1 and 2. In contrast, the 2.3 Kb transcripts (types 3 and 4) are terminated after the polyadenylation signal in exon 11. The deleted 88 nt 5' untranslated sequence found in transcript types 2 and 4 is due to exon skipping in which exon 1 is spliced directly to exon 3. The 239 nucleotide deletion from the 5' end of transcript type 5 is also due to exon skipping in which exon 1 is spliced

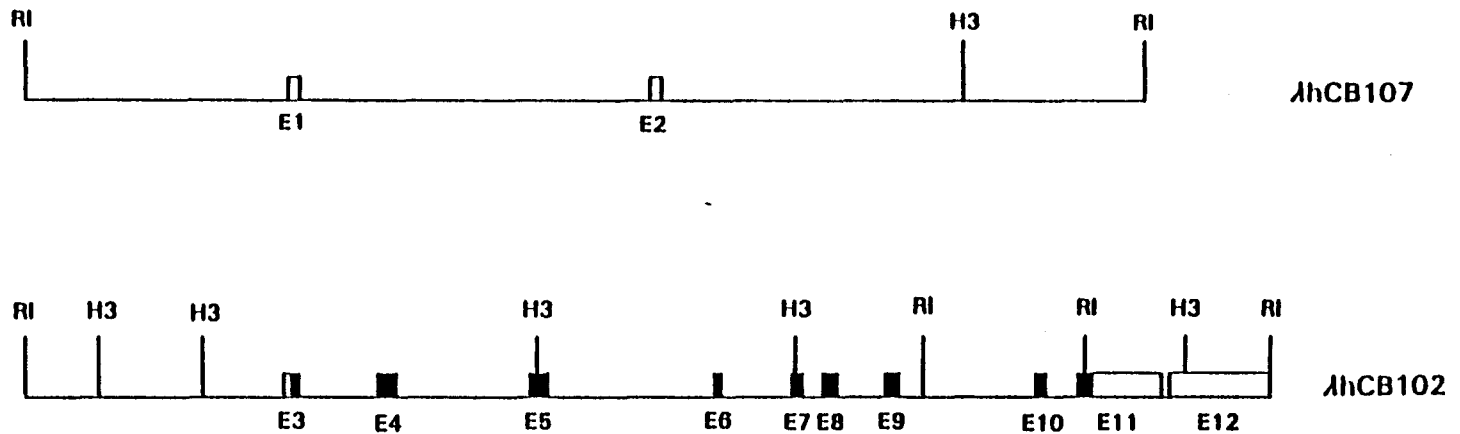

Figure 24. Organization of human cathepsin B gene. The introns and exons are shown. The solid areas are the regions which encode preprocathepsin B. Phage λ hCB107 contains a 11,500 bp insert which include first two exons containing the 5' untranslated region. Phage λ hCB102 contains a noncontiguous 13,500 bp insert which includes the remaining 9 exons numbered 3-11. Also shown are restriction sites.

directly to exon 4.

The nucleotide sequences of the cathepsin B gene at all the exon - intron junctions conform to the canonical GT/AG rule (Table 4) (Breathnach and Chambon, 1981), so that the generation of cathepsin B transcripts with variant 5'-ends can not be explained simply as the result of a poor splice donor-acceptor pair between exons 1 and 2, and between exons 2 and 3. Similarly, the generation of cathepsin B mRNAs with variant 3'-UTRs can not be explained as being due to a poor splice donor-acceptor pair between exons 11 and 12. Factors which regulate alternative splice selection will be described later.

In addition to these five types of cathepsin B transcripts in Figure 23, other transcripts have been reported. Human colorectal tumors contain low levels of two additional messages of 1.5 Kb and 3 Kb (Murnane *et al.* 1991). Human osteoclastomas, which also consist of large numbers of apparently normal osteoclasts, contain 2.4, 1.9 and 1.2 Kb cathepsin B-related mRNAs (Page *et al.* 1992). The origins and sequences of these transcripts are unclear. In my studies, transcripts smaller than 2.3 Kb were not detected by Northern blot analysis.

Multiple forms of cathepsin B transcripts have also been found in murine melanomas (Qian *et al.* 1989). Murine B16 melanoma cells contain three transcripts for cathepsin B, a 2.2 Kb form also seen in normal tissues, and two larger

Table 4. Exon-intron organization of the human cathepsin B gene

exon	exon size	5'splice donor	intron size	3'splice acceptor
1	124 bp	5' UT CGCTGGgtgag...	3500 bp	5' UT ...tcccagGCTGGT
2	88	5' UT CGAGTAgtaag...	5000	5' UT ...ctccagGTGGAT
3	151	TrpGln TGGCAGgtagg...	820	AlaGly ...ttccagGCCGGG
4	86	GlnArg CCAGAGgtgag...	1450	ValMet ...atccagAGTTATG
5	115	CysTrp TGCTGGgtaag...	1750	AlaPhe ...ctgcagGCCTTC
6	119	AspGly GGACGGgtaag...	750	CysAsn ...tttcagCTGTAAT
7	86	HisVal CATGTAGgtaag...	230	GlyCys ...catcagGGTGCA
8	114	HisTyr CACTACGgtaag...	470	GlyTyr ...ttccagGATACA
9	117	LysSer AAGTCAGgtgct...	1380	GlyVal ...tttcagGAGTGT
10	129	AspAsn GACAATGgtgag...	470	GlyPhe ...tcccagGCTTCT
11	142*	3' UT ATCGGGgtaga...	823	3' UT ...ctgcagAGAATC
12	2700			

*Exon 11 = 886 bp for 2.3 Kb cathepsin B mRNAs (types 3 and 4) in which the alternative splice site donor site is not utilized. UT stands for untranslated.

transcripts of 4 Kb and 5 Kb only observed in the melanomas. Recently, a 4 Kb message for cathepsin B has been reported in metastatic *ras*-transformed NIH 3T3 cells (Chambers *et al.* 1992). Moin *et al.* (1989), employing a human cathepsin B cDNA probe, have also observed a 4 Kb transcript in normal mouse liver. However, Qian *et al.* (1989; 1991c) were unable to detect 4 and 5 Kb messages for cathepsin B in normal mouse liver, kidney, and spleen using either a cathepsin B cDNA probe or a fragment from the 3'-end of the mouse cathepsin B gene specific for the larger transcripts from melanoma cells. These variant transcripts were found to encode the same cathepsin B precursor protein but to differ in the lengths of their 3'-untranslated regions (Qian *et al.* 1991b; Qian *et al.* 1991c). The use of alternative polyadenalation signals, which is also seen with the human cathepsin B gene, explains the differences between these variant cathepsin B transcripts in mouse melanomas.

B. Levels of Expression of Variant Cathepsin B mRNAs in Human Normal Tissues and Tumors

Many reports have indicated an association between cathepsin B and cancer. Elevated levels of cathepsin B have been correlated with increased metastatic potential or invasiveness in a variety of tumors from humans (Pietras and Roberts, 1981; Recklies *et al.* 1982; Dufek *et al.* 1984; Watanabe *et al.* 1989; Sheahan *et al.* 1989) and rodents (Sloane *et al.* 1982; Koppel *et al.* 1984; Sloane *et al.* 1986). Indeed,

elevated cathepsin B expression has been thought to be a marker of the tumorigenic and/or malignant state (Sloane et al. 1982; Koppel et al. 1984). Most of these studies used enzymatic or immunochemical methods to detect and quantitate the enzyme. However, using activity measurements to estimate enzyme levels suffers from uncertainties concerning the specificity of the substrates, and the presence of different amounts of endogenous inhibitors and activators in different tissues which may lead to an under- or over-estimation of the enzyme. Immunochemical methods may be compromised by the cross-reactivity between closely related cysteine proteinases (Wiederander and Kirschke, 1986). In this present study, I have employed cDNA for human cathepsin B to examine its expression in normal human tissues and cultured melanoma cells of different metastatic properties. The mRNA levels for melanomas A375P (parental, poorly metastatic) and A375M (metastatic) are 1.5 and 2.3 fold higher respectively than that for kidney and spleen, the tissues with the highest expression of cathepsin B among the five normal tissues studied. This result is in agreement with the reports of enhanced cathepsin B activities observed in a variety of tumors such as murine fibrosarcomas (Keren and LeGrue, 1988), human liver cancer (Dufek et al. 1984), human ovarian carcinoma (Mort et al. 1981), human genital tract cancer (Pietras and Roberts, 1981) and human breast carcinoma (Recklies et al. 1982). The elevated levels of cathepsin B

mRNA in human melanoma cells suggested that in these cells cathepsin B expression is regulated, at least in part, at the level of transcription and/or mRNA stability.

Post-transcriptional mechanisms may also be involved in the regulation of cathepsin B expression. As mentioned above, cathepsin B mRNA is heterogeneous due to differences in processing of the 5'- and 3'-ends. The selection of variant 5' splice donor sites in exon 11 produces messages which differ in the lengths of their 3'-UTRs. Although the functional significance of mRNAs which vary in their 3'-UTRs is not known in most cases, modification at the 3'-ends of messages have been shown to affect rates of mRNA turnover (Brawerman, 1987; Ross, 1988) and ability to be translated into protein (Kruys et al. 1987). We have shown that both 4.0 Kb (types 1 and 2 in Figure 23) and 2.3 Kb transcripts (types 3 and 4 in Figure 23) were expressed in the normal tissues we examined and in cultured melanoma cells. There may be subtle differences in the expression of the 2.3 Kb transcript versus 4.0 Kb transcript in certain tissues (Table 2). As large differences in the relative abundances of the 2.3 and 4.0 Kb transcripts were not observed between normal tissues and tumor cells, the regulatory significance of these two cathepsin B mRNA forms is unclear at present. The significance of the longer 3'-UTRs in the 4.0 kb and 5.0 kb cathepsin B mRNAs in murine tumors also remains unknown.

Human cathepsin B transcript types 2 and 4 (Figure 23)

were found to result from the occasional skipping of exon 2 during pre-mRNA processing, resulting in an 88 nt deletion from their 5'-UTRs. Differences in the length of the 5'-UTR of the messages has also been shown to affect mRNA stability (Brawerman, 1987) and translation efficiency (Young et al. 1981; Waterhouse et al. 1990; Horiuchi et al. 1990; Manzella and Blackshear, 1990; Foyt et al. 1991; Bares et al. 1991; Kim et al. 1992). In this study, I have observed a greater than 30 fold difference in the relative levels of the two types of messages in normal human tissues (Table 3). Thus, cathepsin B mRNAs which contain the truncated 5'-UTR were barely detectable in skeletal muscle, but were the majority in liver and spleen. Human tumors not only contained higher levels of mRNA for cathepsin B, but the preponderant messages in tumors also contained the shorter 5'-UTR (Table 3). These observations suggest that alternative processing of the 5'-UTR of cathepsin B pre-messages may contribute to the regulation of cathepsin B expression. The differential expression of mRNA with variant 5'-UTR in different tissues has been demonstrated for some other genes, for example, human insulin-like growth factor II gene (Shen et al. 1988), human complement protein C2 (Horiuchi et al. 1990), mouse complement factor B gene (Nonaka et al. 1989), mouse α -amylase gene (Shaw et al. 1985) and *Drosophila* alcohol dehydrogenase gene (Benyajati et al. 1983; Bond and Davidson, 1986).

Another potentially significant finding in this study is

the presence in human breast and colon carcinomas and in human melanoma of a fifth type of cathepsin B message which lacks exon 2 (non coding) and also exon 3 (encoding the 17 residue signal peptide and 25 residues of the activation propeptide) (Figure 12 and 15). The 5'-end of this transcript was cloned by PCR techniques (Figure 15) and its identity was confirmed by sequencing (Figure 16). Reverse transcription and PCR amplification confirmed that this transcript contained the remainder of the procathepsin B coding sequence and the 3'-UTR characteristic of normal cathepsin B transcript (Figure 17). Further characteristic of this transcript and its significance in the regulation of cathepsin B expression are discussed below.

C. Mechanisms of Alternative Splicing

The mechanisms involved in the regulation of alternative splicing are the subject of intense study. Though not presently well understood, several themes are emerging. Alternative splicing often appears to be achieved by subtle variations of the basic mechanisms of RNA processing. Many studies have shown that differential splice site utilization involves the selection of a variant of a *cis* element, such as the consensus sequence around the 5' and 3' splice-site and around the branch point (Ruskin et al. 1985; Aebi et al. 1986; Smith and Nadal-Ginard, 1989). In the case of human cathepsin B, alternative splicing at the 5' end is not due to the

selection of a variant consensus sequence at the 5' and 3' splicing sites, as discussed above.

Regulation of alternative splicing also involves differences in cellular *trans*-acting factors that usually assemble with the transcript into a splicing complex. Cases of alternative splicing, where identical pre-mRNA transcripts give rise to different mRNAs in a cell-type or developmental stage-specific manner, clearly demonstrate that the splicing environment of different cells varies for these transcripts (Breitbart and Nadal-Ginard, 1987; Wieczorek *et al.* 1988). The different distributions of variant cathepsin B mRNAs resulting from alternative splicing in human tissues and tumors are more likely due to differences in the cellular *trans*-acting factors which are involved in pre-mRNA processing.

The *trans*-acting factors which have been identified to be associated with pre-mRNA processing include snRNP, hnRNP proteins and several other protein factors. U1, U2, U4/U6, and U5 snRNPs are the most extensively characterized functional components of the spliceosome where pre-mRNA splicing takes place (Padgett *et al.* 1983; Krainer *et al.* 1984; Kramer *et al.* 1984; Black *et al.* 1985; Black *et al.* 1985; Chabot *et al.* 1985; Black and Steitz, 1986). Some snRNAs show sequence heterogeneity (Lund, 1988) and are regulated in a developmental and tissue-specific manner (Kato and Harada, 1985; Lund *et al.* 1985; Lund and Dahlberg, 1987;

Fu et al. 1988; Krof et al. 1988). Some studies of snRNP proteins indicated that these could be modified by phosphorylation (Woppman et al. 1988). Thus, differentially modified snRNP protein components, as well as snRNA-sequence heterogeneity may allow for functionally distinct, tissue-specific or developmentally regulated snRNPs which could permit cells to tune the existing splicing machinery and facilitate differential splice-site utilization. Alterations in U1 snRNP levels have also been shown to affect splice site selection in both artificial and natural pre-mRNAs (Green, 1991).

In addition to the above snRNPs, several protein factors have been shown to be required for splicing, such as hnRNP proteins, A1, A2, B1, B2, C1, C2, and D, which were associated with hnRNA (Dreyfuss, 1986; Chung and Wooley, 1986; Ruby and Abelson, 1991; Conway et al. 1988; Gil et al. 1991; Patton et al. 1991), and splicing factor SF2 (Krainer et al. 1990a,b). Recently, Mayeda and Krainer (1992) reported that hnRNP A1 and splicing factor SF2 could regulate alternative pre-mRNA splicing *in vitro*. They demonstrated that changes in the relative concentrations of SF2 and hnRNP A1 could modulate alternative 5' splice site selection *in vitro* in some natural pre-mRNAs, such as the adenovirus E1A pre-mRNA. These splicing factors did not appear to operate in a substrate-specific manner, but rather they had a general effect on the polarity of alternative 5' splice-site selection. Thus, an

excess of SF2 over hnRNP A1 consistently resulted in activation of proximal 5' splice sites, whereas an excess of hnRNP A1 over SF2 generally favors distal 5' splice sites. If regulation of alternative 5' splice-site selection by hnRNPA1 and SF2 takes place *in vivo*, the concentration or the activities of one or both of these factors is predicted to be subject to tissue-specific, developmental, or physiological control. Interestingly, the intracellular concentration of hnRNP A1 has been reported to increase in proliferating versus quiescent cells (LeSturgeon *et al.* 1977; de Koch *et al.* 1981; Celis *et al.* 1986; Planck *et al.* 1988). In addition, specific transformation-related changes in the alternative splicing patterns of several cellular genes have been reported (Boris *et al.* 1987; Zardi *et al.* 1987; Goodwin *et al.* 1991). This present study also demonstrates that the human cathepsin B gene can undergo changes in splicing patterns in tumor cells. These results together with the role of hnRNP A1 and SF2 in the alternative splicing suggested that quantitative differences in hnRNP A1 and SF2 might contribute to these transformation-related changes in gene expression. The effect of hnRNP A1 and SF2 on the changes of alternative splicing in human cathepsin B pre-mRNA among different normal tissues and tumors can be tested by quantification of hnRNP A1 and SF2 in these tissues.

Another possibility for different distribution of variant human cathepsin B mRNA in normal tissues and tumors may be

differences in cellular factors which affect stability of the respective mRNAs. This alternative hypothesis can also be tested directly by measuring the rates of decay of the variant messages.

D. Comparison of Translational Activities of Cathepsin B mRNAs with Variant 5'-UTRs

As discussed above, multiple forms of cathepsin B cDNAs which differ in their lengths of 5'-UTRs have been cloned. The results of RNase protection assays confirmed the presence of cathepsin B mRNAs with different 5'-UTRs in human normal tissues and tumors, and also revealed that the ratio of transcripts with a full length 5'-UTR to truncated forms varied widely among normal human tissues, and between normal tissues and tumors. Forms containing a truncated 5'-UTR (lacking exon 2) were much more abundant in human tumors than that in normal tissues. Many studies have demonstrated that 5'-UTR can affect translational capacity of a transcript. To investigate the possible role of the 5'-UTR of cathepsin B transcripts on their translation, the translation efficiencies of cathepsin B mRNAs differing in their 5'-UTRs were studied in this present work. Transcripts lacking exon 2 were twice as active as those containing exon 2 in an *in vitro* translation assay employing synthetic capped RNAs and a reticulocyte lysate (Figure 19 and 21), suggesting that the *in vitro* translation of cathepsin B is under the control of the 5'-UTR. These results together with those from the RNase

protection assays suggest that alternative splicing of the 5'-UTR of cathepsin B may play a role in the regulation of cathepsin B expression.

The mechanisms involved in regulation of translation by 5'-UTR have been studied, and three properties of the 5'-UTR have been shown to influence the translatability of an mRNA (Kozak, 1991a,b): (1) the presence of GC rich sequences which can modify secondary structure; (2) the presence of short open reading frames; (3) the length of the 5'-UTR. Rao *et al.* (1988) demonstrated that 5'-UTR of *c-sis*/platelet-derived growth factor 2 (PDGF-2) transcript exerted an inhibitory effect on translation. This transcript contains a long 5'-UTR that is highly GC rich and can form stable secondary structures. Deletion of the 5'-UTR resulted in as much as a 10 fold increase in *c-sis* PDGF-2 expression *in vivo*. There is growing evidence that expression of a gene may be negatively modulated at the translational level by stable secondary structures in the 5'-UTR of mRNA. It has been observed that the translation rate of ornithine decarboxylase mRNA containing full length 5'-UTR was much lower than that of mRNA containing no 5' lead sequence in both *in vivo* and *in vitro* assays (Grens and Scheffler, 1990; Manzella and Blackshear, 1990). This effect was shown to be due to the GC-rich segment of the UTR which has the potential to form a very stable hairpin structure. The effect of secondary structure in the 5'-UTR on the translation of a transcript has also been

studied by insertion of a synthetic oligonucleotide designed to create a hairpin structure upstream from the ATG initiation codon of preproinsulin transcripts (Kozak, 1986; Kozak, 1989). The results revealed that the hairpin structures in the range of stability of $\Delta G = -50$ kcal/mol could reduce the efficiency of translation 85 to 95%, whereas weaker secondary structures ($\Delta G = -30$ kcal/mol) did not affect the rate of translation. It was thought that the weaker secondary structure could be readily melted by functional 40S ribosomal subunits which are presumed to bind to the capped 5' end of an mRNA and migrate linearly until reaching the first AUG codon where they are joined by a 60S subunit. In contrast, stable secondary structure could block the migration of the 40S subunits.

Another factor which can affect translational efficiency is the presence of an open reading frame in the 5'-UTR. The occurrence of an upstream AUG start codon which is followed shortly by a termination codon to create a small open reading frame at the 5'-end of the mRNA nearly always reduces the efficiency of translation initiation from a downstream AUG codon. Impairment of translation by an open reading frame burdened 5' untranslated leader sequence has been reported for many mRNAs, such as rat insulin-like growth factor I (Foyt et al. 1991; Lowe et al. 1987), rat farnesyl pyrophosphate synthetase (Teruya et al. 1990), rat thyroid hormone receptor (Murray et al. 1988), human interleukin-7 (Young et al. 1991), human and mouse interleukin-2 receptor (Weinberg and Swain,

1990), human fibroblast growth factor-5 (Bares *et al.* 1991) and transforming growth factor- β 3 (Arrick *et al.* 1991). The simplest explanation is that, after a ribosome translates the upstream open reading frame, the 40S ribosomal subunit may reinitiate at another AUG codon downstream. The inhibitory effect of the upstream AUG codon may be attributable to the inefficiency of this reinitiation. Reinitiation could be inefficient for a variety reasons. One possibility is that ribosomes frequently dissociate from mRNA at the upstream termination codon. A related possibility is that ribosomes remain on the mRNA but are unable to recruit other components of translation initiation before reaching the second downstream open reading frame. A third mechanism of inhibition can be imagined in which ribosomes become stalled at the upstream open reading frame, thereby blocking further scanning downstream (Mueller and Hinnebusch, 1986).

In addition to secondary structures and open reading frames in the 5'-UTR, the length of 5'-UTR has also been shown to affect the translation of mRNA. The transcript of the human complement protein C2 has an unusually long 5'-UTR (388 nt). Deletion of this region resulted in a 10 fold enhancement in the translational efficiency of C2 in transient eukaryotic cellular assays (Horiuchi *et al.* 1990). A decreased translation rate due to the lengthening of the 5' noncoding sequence was also found for the genes of murine tissue inhibitor of metalloproteinases (Waterhouse *et al.*

1990), rat guanylate cyclase (Chinkers *et al.* 1989) and human θ globin (Leung *et al.* 1989). It has been reported that RNAs containing a 5'-UTR greater than 200 nt were translated much less efficiently than their truncated counterparts by eukaryotic ribosomes *in vitro* (Young *et al.* 1981). Because in most cases the originally long 5'-UTRs contain sequences which can form secondary structures, there is argument that the effect of this kind of 5'-UTR on the translation might be due to both length and secondary structure. Recently Kozak (1991c,d) has used synthetic 5' noncoding sequences which were designed to increase the length of the 5'-UTR without introducing secondary structure to study the effect of the length of 5'-UTR on translation. In contrast to the negative effect on translation reported previously, she found that lengthening the 5' noncoding sequence of transcripts could increase their translational efficiency under conditions of translation in reticulocyte lysates. In these cases translation efficiency was proportional to leader length in the range of 17 to about 80 nucleotide. It seems likely that long 5' leader sequences appear to accumulate extra 40S ribosomal subunits, which may account for their translational advantage. However, the effect on translation of inserting more than 80 nucleotides of synthetic sequence prior to the AUG codon remains unknown.

The 88 nt exon 2 of human cathepsin B transcripts, which is sometimes spliced out of the 5'-UTR to generate transcript

with truncated 5'-UTR, has features which can affect the translation efficiency of the transcript. It extends the 5'-UTR to 237 nucleotides for full length 5'-UTR, contains an adjacent start and stop codon upstream from the normal translation start site and is GC rich. In addition, a preliminary computer analysis of the secondary structure of cathepsin B cDNA indicates that there is a potential for formation of a stable stem-loop structure between part of exon 2 and a nearby downstream sequence. These features may explain the decreased translational activity of the cathepsin B transcript with the full length 5'-UTR in the *in vitro* assay compared to that of the cathepsin B transcript missing exon 2.

E. Characteristics of Cathepsin B Transcript Missing Exons 2 and 3

A significant new finding in this present work is the detection in human breast and colon carcinomas and in human melanomas of a fifth type of cathepsin B transcript which lacks exon 2, noncoding, and exon 3 encoding the 17 residue signal peptide and 25 residues of the activation peptide (Figure 12, 15, 17, and 24). I have shown that this transcript is complete in that it contains the remainder of the cathepsin B coding sequence and part of the 3'-UTR which is common to all full length cathepsin B mRNAs (Figure 17). I have also demonstrated by *in vitro* transcription and translation that the corresponding synthetic message lacking exons 2 and 3 can be translated, possibly from an in-frame

internal methionine (residue 52) within the propeptide region. The resulting 32 KDa protein product (Figure 22) would lack the signal peptide which is required for directing cathepsin B to the lysosomes, and the first 34 residues of the 62 amino acid propeptide which inhibits enzyme activity. Remarkably, this RNA is 4 times more active in the reticulocyte lysate than an RNA lacking exon 2, and 8 times more active than the RNA containing the full length 5'-UTR. Furthermore, I determined that this truncated product can be folded to produce a native structure.

After treatment of an *in vitro* translation mixture with decreasing concentrations of guanidinium hydrochloride to promote refolding, cathepsin B enzyme activity could be detected. In contrast, treatment with an "oxido-shuffling" buffer to promote disulfide bond formation failed to generate an active enzyme. The ability to acquire enzymatic activity is a highly stringent test of folding into a native conformation. Results in Figure 22 show that the activity obtained after dialysis against decreasing concentrations of guanidinium hydrochloride is easily detected by the standard cathepsin B assay. This demonstrates that the 32,000 dalton truncated form of cathepsin B can be refolded to produce an active species, and that the missing propeptide region of this protein product is not essential for correct folding. I also found that treatment of the refolded product with pepsin, to remove the remainder of the activation propeptide, increased

its activity three fold. We postulated that either the removal of the entire activation propeptide may not be necessary for activation, or some of the enzyme may undergo autolysis during folding which removed the remainder of the propeptide.

These results indicated that cathepsin B transcripts from human tumors which lacks exons 2 and 3 are likely to be functional mRNAs. Our ability to refold the translated product of the corresponding synthetic mRNA into an active enzyme *in vitro* increases the likelihood that such message would produce a stable, active protein *in vivo*. Further, we can speculate that this molecular form of cathepsin B, missing the N-terminal signal peptide, may no longer be targeted to the lysosome.

Cellular transformation and other pathological changes can be accompanied by a redistribution of cathepsin B to secretory vesicles (Docherty *et al.* 1984; Saluja *et al.* 1989; Achkar *et al.* 1990), the plasma membrane (Pietras and Roberts, 1981; Sloane *et al.* 1987; Keren and LeGrue, 1988; Weiss *et al.* 1990) and the nucleus (Pietras and Roberts, 1981). Transformed cells also contain and secrete several different molecular forms of cathepsin B including higher molecular weight latent and active forms (Recklies *et al.* 1980; Mort *et al.* 1980; Dufek *et al.* 1984; Biaci and Knopeel, 1986; Petrova-Skalkova *et al.* 1987; Keppler *et al.* 1988b; Docherty and Phillips, 1988; Maciewicz *et al.* 1989). Some of these undoubtedly reflect alterations in the linked targeting and

posttranslational processing of the cathepsin B which result in changes in the amount and composition of oligosaccharide side chain (Keppler et al. 1988b; Nishimura et al. 1988) and the extent of proteolytic modifications (Chan et al. 1986; Hara et al. 1988). Our present results also raise the possibility that in some human tumors a part of this diversity of form and location may be due to alternative splicing of cathepsin B pre-mRNA. One can speculate that the putative product of a cathepsin B mRNA missing exon 3 could have a cytosolic and/or nuclear location and could participate in the modulation of cellular activity by the limited proteolytic modification of key regulatory proteins. Interestingly, it has recently been shown that the product of the c-Ha ras gene is structurally homologous to some members of the cystatin type II gene family, and can bind to cathepsin B and related enzymes with high affinity (Hiwasa et al. 1987; Rawlings and Barrett, 1990).

CHAPTER VI

SUMMARY

1. Multiple forms of cathepsin B transcripts, which result from alternative processing in the 5' and 3' untranslated regions (UTRs), have been identified in normal human tissues and human tumors by Northern blot and RNase protection assays.

2. The relative levels of the cathepsin B transcripts (2.3 Kb and 4.0 Kb) differing in the lengths of their 3'-UTRs has been measured in normal human skeletal muscle, kidney, liver, spleen and colon, and in the two human melanoma variants A375P and A375M by Northern blot. The ratios of the 2.3 Kb transcript to the 4.0 Kb transcript only varied by about a factor 2, from 2.8 to 6.2. Thus, the regulatory significance of these two cathepsin B mRNA forms is unclear at present.

3. The relative levels of the cathepsin B mRNAs which differ in the lengths of their 5'-UTRs were also measured by RNase protection assays in normal human skeletal muscle,

kidney, liver, spleen and colon, in samples from human colon and breast carcinomas, and in several established cultured human tumor cell lines, two prostate carcinoma variants, PC3P and PC3M, two melanoma variants A375P and A375M, and colon carcinoma. The ratios of the transcript lacking exon 2 to that containing exon 2 varied widely from less than 0.1 to 3 for the normal tissues, and from 6.0 to 24 for the tumors and tumor derived cell lines. Thus, transcripts with the shorter 5'-UTR were much more abundant in tumors than in normal tissues.

3. An *in vitro* transcription/translation assay was used to demonstrate that the cathepsin B transcripts with variant 5'-UTRs differ in their rates of translation. The relative rates are about 2:1 for mRNAs lacking exon 2 to mRNAs containing the full length 5' end.

4. Human breast and colon carcinomas and human melanomas, A375P and A375M, contain a cathepsin B transcript which is also missing exon 3 encoding the signal peptide and 7 residues of the activation propeptide. This transcript is complete, and contains the remainder of the cathepsin B coding sequence and part of the 3'-UTR which is common to all full length cathepsin B mRNAs.

5. An *in vitro* transcription/translation assay was used

to demonstrate that cathepsin B transcripts missing exon 3 could be translated from an internal methionine codon (residue 52), producing a 32 KDa product lacking the signal peptide and more than half the propeptide. This truncated form of cathepsin B should no longer be targeted to the lysosome.

6. Finally, the translation product from the message missing exons 2 and 3 was able to acquire a native-like conformation after refolding *in vitro*. This refolded, truncated protein was active against the specific substrate, N-benzyloxycarbonyl-L-arginyl-L-arginine-7-amido-4-methylcoumarin (Z-Arg-Arg-AMC). Treatment with pepsin, to remove the remainder of the activation propeptide, increases catalytic activity 3 fold. These results indicate that cathepsin B mRNA lacking exons 2 and 3 is likely to be a functional mRNA.

These findings suggest that alternative splicing of cathepsin B pre-mRNA may be involved in regulating the expression and subcellular distribution of cathepsin B in human tissues and tumors.

BIBLIOGRAPHY

- Achkar, C., Gong, Q., Frankfater, A., and Bajkowski, A.S. (1990). Differences in targeting and secretion of cathepsin B and L by BALB/3T3 fibroblasts and Moloney murine sarcoma virus-transformed BALB/3T3 fibroblasts. *J. Biol. Chem.* **265**:13650-13654.
- Aebi, M., Hornig, H., Padgett, R.A., Reiser, J., and Weissmann, C. (1986). Sequence requirements for splicing of higher eukaryotic nuclear pre-mRNA. *Cell* **47**:555-565.
- Aebi, M., Hornig, H., and Weissman, C. (1987). 5' cleavage site in eukaryotic pre-mRNA splicing is determined by the overall 5' splice region, not by the conserved 5' GU. *Cell* **50**:237-246.
- Aho, S., Tate, V., and Boedtker, H. (1983). Multiple 3' ends of the chicken pro $\alpha 2(I)$ collagen gene. *Nucleic Acids Res.* **11**:5443-5450.
- Alt, F.W., Bothwell, A.L.M., Knapp, M., Siden, E., and Mather, E. (1980). Synthesis of secreted and membrane bound immunoglobulin m heavy chains is directed by mRNAs that differ at their 3' ends. *Cell* **20**:293-302.
- Amara, S.G., Jonas, V., and Rosenfeld, M.G. (1982). Alternative RNA processing in calcitonin gene expression generates mRNAs encoding different polypeptide products. *Nature* **298**:240-244.
- Aronson, N.N. and Barrett, A.T. (1978). The specificity of cathepsin B: Hydrolysis of glucagon at the C-terminus by a peptididipeptidase mechanism. *Biochem. J.* **171**:759-765.
- Arrick, B.A., Lee, A.L., Grendell, R.L., and Derynck, R. (1991). Inhibition of translation of transforming growth factor- $\beta 3$ mRNA by its 5' untranslated region. *Mol. Cell. Biol.* **11**:4306-4313.
- Bajkowski, A.S. and Frankfater, A. (1975). Specific spectrophotometric assays for cathepsin B1. *Anal. Biochem.* **68**:119-127.

Bajkowski, A.S. and Frankfater, A. (1983a). Steady state kinetic evidence for an acyl-enzyme intermediate in reactions catalyzed by bovine spleen cathepsin B. *J. Biol. Chem.* **258**:1645-1649.

Bajkowski, A.S. and Frankfater, A. (1983b). The pH dependency of bovine spleen cathepsin B catalyzed transfer of N-benzyloxycarbonyl-L-lysine from p-nitrophenol to water and dipeptide nucleophiles. Comparisons with papain. *J. Biol. Chem.* **258**:1650-1655.

Bares, B., Hardin, J., Zhan, X., Drickamer, K., and Goldfarb, M. (1991). Biosynthesis of human fibroblast growth factor-5. *Mol. Cell. Biol.* **11**:1840-1845.

Barrett, A.J. (1973). Human cathepsin B1 purification and some properties of the enzyme. *Biochem. J.* **131**:809-822.

Barrett, A.J. (1980a). *Proteolysis in health and disease*. Excerpta Medica, Amsterdam.

Barrett, A.J. (1980b). *Proteinases and tumor invasion*. Raven Press, New York.

Barrett, A.J. (1984). Proteolytic and other metabolic pathways in lysosomes. *Biochem. Soc. Trans.* **12**:899-902.

Barrett, A.J. (1987). Proteinases in mammalian cells and tissues. In: *Proteinases in mammalian cells and tissues*, edited by A.J. Barrett, pp. 181-208. North-Holland, Amsterdam.

Barrett, A.J. and Kirschke, H. (1981). Cathepsin B, cathepsin H, and cathepsin L. *Methods Enzymol.* **80**:536-561.

Barth, R. and Elce, J.S. (1981). Immunofluorescent localization of a Ca-dependent neutral protease in hamster muscle. *Am. J. Physiol.* **240**:E493-E498.

Baumbach, W.R., Horner, D.L., and Logan, J.S. (1989). The growth hormone-binding protein in rat serum is an alternatively spliced form on the rat growth hormone receptor. *Genes Dev.* **3**:1199-1205.

Bayliss, M.T. and Ali, S.Y. (1978). Studies on cathepsin B in human articular cartilage. *Biochem. J.* **171**:149-154.

Bellelli, A., Mattioni, M., Rusconi, V., Sezzi, M.L., and Bellelli, L. (1990). Inhibition of tumor growth, invasion and metastasis in papain-immunized mice. *Inva. Metastasis* **10**:142-169.

Benyajati, C., Spoerel, N., Haymerle, H., and Ashburner, M.

(1983). The messenger RNA for alcohol dehydrogenase in *Drosophila melanogaster* differ in its 5' end in different developmental stages. *Cell* 33:125-133.

Berget, S.M. and Robberson, B.L. (1986). U1, U2 and U4/U6 small nuclear ribonucleoproteins are required for in vitro splicing but not polyadenylation. *Cell* 46:691-696.

Biaci, A. and Knopf, M. (1986). Cysteine proteinases produced by cultured rabbit V2 carcinoma cells and rabbit skin fibroblasts. *Int. J. Cancer* 38:753-761.

Bird, J.W.C., Wood, L., Sohar, I., Fekete, E., Colella, R., Yorke, G., Cosentino, B., and Roisen, F.J. (1985). Localization of cysteine proteinases and an endogenous cysteine proteinase inhibitor in cultured muscle cells. *Biochem. Soc. Trans.* 13:1018-1021.

Birnstiel, M.L., Busslinger, M., and Strub, K. (1985). Transcription termination and 3' processing: the end is in site. *Cell* 41:349-359.

Black, D.L., Chabot, B., and Steitz, J.A. (1985). U2 as well as U1 small nuclear ribonucleoproteins are involved in pre-messenger RNA splicing. *Cell* 42:737-750.

Black, D.L. and Steitz, J.A. (1986). Pre-mRNA splicing in vitro requires intact U4/U6 small nuclear ribonucleoprotein. *Cell* 46:697-704.

Bond, B.J. and Davidson, N. (1986). The *Drosophila melanogaster* actin 5C gene uses two transcription initiation sites and three polyadenylation sites to express multiple mRNA species. *Mol. Cell. Biol.* 6:2080-2088.

Boris, L., Carnemolla, B., Castellani, P., Vecchio, D., Allemanni, G., Chang, S.E., Taylor-Papadimitriou, J., Pande, H., and Zardi, L. (1987). Monoclonal antibodies in the analysis of fibronectin isoforms generated by alternative splicing of mRNA precursors in normal and transformed human cells. *J. Cell Biol.* 104:595-600.

Brawerman, G. (1987). Determinants of messenger RNA stability. *Cell* 48:5-6.

Breathnach, R. and Chambon, P. (1981). Organization and expression of eukaryotic split genes coding for proteins. *Annu. Rev. Biochem.* 50:349-283.

Breitbart, R.E. and Nadal-Ginard, B. (1987). Developmentally induced muscle specific trans factors control the differential splicing of alternative and constitutive troponin-T exons.

Cell 49:794-803.

Bretibart, R.T., Nguyen, H.T., Medford, R.M., Destree, A.T., Mahdavi, V., and Nadal-Ginard, B. (1985). Intricate combinatorial patterns of exon splicing generate multiple regulated troponin T isoforms from a single gene. *Cell* 41:67-82.

Buck, M.R., Karustis, D.G., Day, N.A., Honn, K.V., and Sloane, B.F. (1992). Degradation of extracellular-matrix proteins by human cathepsin B from normal and tumor tissues. *Biochem. J.* 282:273-278.

Bystryn, J.C. and Perlstein, J. (1982). Autocatabolism of surface macromolecules shed by human melanoma cells. *Cancer Res.* 42:2232-2237.

Capony, F., Morisset, M., Barrett, A.G., Capony, J.P., Broquet, P., Vignon, F., Chambon, M., Louisot, P., and Rochefort, H. (1987). Phosphorylation, glycosylation and proteolytic activity of the 52k estrogen-induced protein secreted by MCF7 cells. *J. Cell Biol.* 104:253-262.

Capony, F., Rougeot, C., Montcourrier, P., Cavailles, V., Salazar, G., and Rochefort, H. (1989). Increased secretion, altered processing, and glycosylation of pro-cathepsin D in human mammary cancer cells. *Cancer Res.* 49:3904-3909.

Cardozo, C., Kurtz, C., and Lesser, M. (1992). Degradation of rat lung collagens by cathepsin B. *Clin. Medicine* 119:169-175.

Celis, J.E., Bravo, R., Arenstorff, H.P., and LeSturgeon, W.M. (1986). Identification of proliferation-sensitive human proteins among components of the 40 S hnRNP particles: identity of hnRNP core proteins in the HeLa protein catalogue. *FEBS Letters* 194:101-109.

Chabot, B., Black, D.L., LeMaster, D.M., and Steitz, J.A. (1985). The 3' splice site of premessenger RNA is recognized by a small nuclear ribonucleoprotein. *Science* 230:1344-1349.

Chambers, A.F., Colella, R., Denhardt, D.T., and Wilson, S.M. (1992). Increased expression of cathepsins B and L and decreased activity of their inhibitors in metastatic, ras-transformed NIH 3T3 cells. *Mol. Carcinogenesis* 5:238-245.

Chan, S.J., Segundo, B.S., McCormick, M.B., and Steiner, D.F. (1986). Nucleotide and predicted amino acid sequences of cloned human and mouse preprocathepsin B cDNAs. *Proc. Natl. Acad. Sci. U. S. A.* 83:7721-7725.

Chinkers, M., Garbers, D.L., Chang, M.S., Lowe, D.G., Chin, H., Geodde, D.V., and Schulz, S. (1989). A membrane form of guanylate cyclase is an atrial natriuretic peptide receptor. *Nature* 338:78-83.

Choi, Y.D., Grabowski, P.J., Sharp, P.A., and Rreyfuss, G. (1986). Heterogeneous nuclear ribonucleoproteins: role in RNA splicing. *Science* 231:1534-1539.

Chomczynski, P. and Sacchi, N. (1987). Single-step method of RNA isolation by acid guanidinium thiocyanate-phenol-chloroform extraction. *Anal. Biochem.* 162:156-159.

Chung, S.Y. and Wooley, J. (1986). Set of novel, conserved proteins fold pre-messenger RNA into ribonucleosomes. *Proteins* 1:195-210.

Conway, G., Wooley, J., Bibring, T., and LeStourgeon, W.M. (1988). Ribonucleoprotein package 700 nucleotides of pre-mRNA into a repeating array of regular particles. *Mol. Cell. Biol.* 8:2884-2895.

d'Orval, B.C., Carafe, Y.D., Sirand-Pugnet, P., Gallego, M., Brody, E., and Marie, J. (1991). RNA secondary structure repression of a muscle-specific exon in Hela cell nuclear extracts. *Science* 252:1823-1828.

Daries, M., Barrett, A.J., Travis, J., Sanders, E., and Coles, G.A. (1978). The degradation of human glomerular basement membrane with purified lysosomal proteinases: evidence for the pathogenic role of the polymorphonuclear leucocyte in glomerulonephritis. *Clinical Sci. Mol. Med.* 54:233-240.

Dayton, W.R. and Schollmeyer, J.V. (1981). Immunocytochemical localization of a calcium-activated protease in skeletal muscle cells. *Exper. Cell Res.* 136:423-433.

de Koch, I.G., Wilk, H.E., and Schafer, K.P. (1981). Con A stimulated bovine lymphocytes: a model to study protein and RNA components of nuclear ribonucleoprotein particles. In: *Mechanisms of lymphocyte activation*, edited by K. Resch, et al, pp. 222-225. Elsevier, Amsterdam.

Delaisse, J.M., Ledent, P., and Vase, G. (1991). Collagenolytic cysteine proteinases of bone tissue: cathepsin B, (pro)cathepsin L and a cathepsin L-like 70 kDa proteinase. *Biolchem. J.* 279:167-174.

Dengler, R., Lah, T., Gabrijelcic, D., Turk, V., Fritz, H., and Emmerich, B. (1991). Detection of cathepsin B in tumor cytosol and urine of breast cancer. *Biomed. Biochem. Acta* 50:555-560.

Docherty, K., Carroll, R., and Steiner, D.F. (1983). Identification of a 31,500 molecular weight islet protease as cathepsin B. *Proc. Natl. Acad. Sci. U. S. A.* **80**:3245-3249.

Docherty, K., Hutton, J.C., and Steiner, D.F. (1984). Cathepsin B-related proteases in the insulin secretory granule. *J. Biol. Chem.* **259**:6041-6044.

Docherty, K. and Phillips, I.D. (1988). Molecular forms of cathepsin B in rat thyroid cells (FRTL5): comparison with molecular forms in liver (HepG2) and insulin-secreting cells (HIT T15). *Biochim. Biophys. Acta* **964**:168-174.

Docherty, K. and Steiner, D.F. (1982). Post-translational proteolysis in polypeptide hormone biosynthesis. *Annu. Rev. Physiol.* **44**:625-638.

Dong, J., Prence, E.M., and Sahagian, G.G. (1989). Mechanism for selective secretion of a lysosomal protease by transformed mouse fibroblasts. *J. Biol. Chem.* **264**:7377-7383.

Dreyfuss, G. (1986). Structure and function of nuclear and cytoplasmic ribonucleoprotein particles. *Annu. Rev. Cell Biol.* **2**:458-498.

Dufek, V., Jirasek, V., Kral, V., Matous, B., and Drazna, E. (1985). Changes in serum cathepsin B-like activity in patients with colorectal cancer. *Neoplasma* **32**:51-54.

Dufek, V., Matous, B., Kral, V., and Bures, L. (1984). Characterization of cathepsin B-like proteinase from ascitic fluid of patients with primary liver cancer. *Neoplasma* **31**:581-590.

Early, P., Rogers, J., Davis, M., Calame, K., Bond, M., Wall, R., and Hood, L. (1980). Two mRNAs can be produced from a single immunoglobulin m gene by alternative RNA processing. *Cell* **20**:313-319.

Edmonds-Alt, X., Quinsquator, E., and Vase, G. (1980). Proteoglycan- and fibrin-degrading neutral proteinase activities of Lewis lung carcinoma cells. *Eur. J. Cancer* **16**:1257-1261.

Eeckhout, Y. and Vaes, G. (1977). Further studies on the activation of procollagenase, the latent precursor of bone collagenase. *Biochem. J.* **166**:21-31.

Eperon, L.P., Estibeiro, J.P., and Eperon, I.C. (1986). The role of nucleotide sequences in splice site selection in pre-messenger RNA. *Nature* **324**:280-282.

Eperon, L.P., Graham, I.R., Griffiths, A.D., and Eperon, I.C. (1988). Effects of RNA secondary structure on alternative splicing of pre-mRNA: is folding limited to a region behind the transcribing RNA polymerase? *Cell* 54:393-401.

Estes, P.A., Cooke, N.E., and Liebhaber, S.A. (1992). A native RNA secondary structure controls alternative splice-site selection and generates two human growth hormone isoforms. *J. Biol. Chem.* 265:14902-14908.

Fessler, L.I., Duncan, K.G., and Fessler, J.H. (1984). Characterization of the procollagen IV cleavage products produced by a specific tumor collagenase. *J. Biol. Chem.* 259:9783-9789.

Figarella, C., Miszezuk-Jamska, B., and Barrett, A.B. (1988). Possible lysosomal activation of pancreatic zymogens activation of both human trypsinogens by cathepsin B and spontaneous acid activation of human trypsinogen 1. *Biol. Chem. Hoppe-Sayler* 369:293-298.

Flickinger, T.W., Maihle, N.J., and Kung, H-J. (1992). An alternatively processed mRNA from the Avian c-erbB gene encodes a soluble, truncated form of the receptor that can block ligand-dependent transformation. *Mol. Cell. Biol.* 12:883-893.

Fong, D., Calhoun, D.H., Hsieh, W.T., Lee, B., and Wells, D. (1986). Isolation of a cDNA clone for the human lysosomal proteinase cathepsin B. *Proc. Natl. Acad. Sci. U. S. A.* 83:2909-2913.

Fontaine, B., Klarsfeld, A., and Changeux, J-P. (1987). Calcitonin gene-related peptide and muscle activity regulate acetylcholine receptor α -subunit mRNA levels by distinct intracellular pathway. *J. Cell Biol.* 105:1237-1342.

Fourney, M.R., Miyakoski, J., Day III, R.S., and Paterson, M.C. (1988). Northern blotting: efficient RNA staining and transfer. *Focus* 10:1:5-6.

Foyt, H.L., LeRoith, D., and Roberts, C.T.Jr. (1991). Differential association of insulin-like growth factor I mRNA variants with polysomes in vitro. *J. Biol. Chem.* 266:7300-7305.

Fu, X-Y., Colgan, J.D., and Manley, J.L. (1988). Multiple cis-acting sequence elements are required for efficient splicing of SV40 small-t antigen pre-mRNA. *Mol. Cell. Biol.* 8:3582-3590.

Gal, S. and Gottesman, M.M. (1986). The major excreted protein

of transformed fibroblasts is an activatable acid-protease. *J. Biol. Chem.* **261**:1780-1785.

Gattoni, R., Schmitt, P., and Stevenin, J. (1988). In vitro splicing of adenovirus E1A transcripts: characterization of novel reactions and multiple branch points abnormally far from the 3' splice site. *Nucleic Acids Res.* **16**:2389-2408.

Ge, H. and Manley, J.L. (1990). A protein factor, ASF, controls cell-specific alternative splicing of SV40 early pre-mRNA in vitro. *Cell* **62**:25-34.

Gil, A., Sharp, P.A., Jamison, S.F., and Garcia-Blanco, M.A. (1991). Characterization of cDNA encoding the polypyrimidine tract-binding protein. *Genes Dev.* **5**:1224-1236.

Gong, Q., Chan, S.J., Bajkowski, A.S., Steiner, D.F., and Frankfater, A. (1993). Characterization of the cathepsin B gene and multiple mRNAs in human tissues: evidence for alternative splicing of cathepsin B pre-mRNA. *DNA Cell Bio.* (in press).

Goodwin, L.O., Lees-Miller, J.P., Leonard, M.A., Cheley, S.B., and Helfman, D.M. (1991). Four fibroblast tropomyosin isoforms are expressed from the rat α -tropomyosin gene via alternative RNA splicing and the use of two promoters. *J. Biol. Chem.* **266**:8408-8415.

Graf, M., Baici, A., and Strauli, P. (1981). Histochemical localization of cathepsin B of the invasion front of the rabbit V2 carcinoma. *Lab. Invest.* **45**:587-596.

Green, M.R. (1991). Biochemical mechanisms of constitutive and regulated pre-mRNA splicing. *Annu. Rev. Cell Biol.* **7**:559-599.

Grens, A. and Scheffler, I.E. (1990). The 5'- and 3'-untranslated regions of ornithine decarboxylase mRNA affect the translational efficiency. *J. Biol. Chem.* **265**:11810-11816.

Grabowski, P.J., Padgett, R.T., and Sharp, P.A. (1984). Messenger RNA splicing in vitro: an excised intervening sequence and possible intermediate. *Cell* **37**:415-427.

Guo, W., Mulligan, G.J., Wormsley, S., and Helfman, D.M. (1991). Alternative splicing of β -tropomyosin pre-mRNA: cis-acting elements and cellular factors that block the use of a skeletal muscle exon in nonmuscle cells. *Genes Dev.* **5**:2096-2107.

Guthrie, C. (1991). Messenger RNA splicing in yeast: clue to why the spliceosome is a ribonucleoprotein. *Science* **253**:157-163.

Hager, D.A. and Burgess, R.R. (1980). Elution of proteins from sodium dodecyl sulfate-polyacrylamide gels removal of sodium dodecyl sulfate, and renaturation of enzymatic activity: result with sigma subunit of Escherichia coli RNA polymerase, wheat germ DNA topoisomerase, and other enzymes. *Anal. Biochem.* 109:76-86.

Hanewinkel, H., Glossl, J., and Kresse, H. (1987). Biosynthesis of cathepsin B in cultured normal and I-cell fibroblasts. *J. Biol. Chem.* 262:12351-12355.

Hara, K., Kominami, E., and Katunuma, N. (1988). Effect of proteinase inhibitors in intracellular processing of cathepsin B, H, and L in rat macrophages. *Febs Letters* 231:229-231.

Hartley, B.S. (1970). Homologies in serine proteinases. *Phil. Trans. Roy. Soc. Lond. Ser. B.* 257:77-87.

Helfman, D.M., Cheley, S., Kuismanen, E., Finn, L.A., and Yamawaki-Kataoka, Y. (1986). Nonmuscle and muscle tropomyosin isoforms are expressed from a single gene by alternative RNA splicing and polyadenylation. *Mol. Cell. Biol.* 6:3582-3595.

Helfman, D.M. and Ricci, W.M. (1989). Branch point selection in alternative splicing of tropomyosin pre-mRNAs. *Nucleic Acids Res.* 17:5633-5650.

Helfman, D.M., Roscigno, R.F., Mulligan, G.J., Finn, L.A., and Weber, K.S. (1990). Identification of two distinct intron elements involved in alternative splicing of β -tropomyosin pre-mRNA. *Genes Dev.* 4:98-110.

Hiwasa, T., Yokoyama, S., Ha, J.-M., Noguchi, S., and Sakiyama, S. (1987). c-Ha-ras gene products are potent inhibitors of cathepsins B and L. *Febs Letters* 211:23-26.

Horiuchi, T., Macon, K., Kidd, V., and Volanakis, J.E. (1990). Translational regulation of complement protein C2 expression by differential utilization of the 5'-untranslated region of mRNA. *J. Biol. Chem.* 265:6521-6534.

Howie, A.J., Burnett, D., and Crocker, J.J. (1985). The distribution of cathepsin B in human tissues. *Pathol.* 145:307-314.

Huisman, w., Lanting, l., Doddema, H.J., Bouma, J.M.W., and Gruber, M. (1974). Role of individual cathepsin B in lysosomal protein digestion as tested by specific inhibitors. *Biochim. Biophys. Acta* 370:297-307.

Imamura, K. and Tanaka, T. (1982). Pyruvate kinase isozymes from rat. *Methods Enzymol.* 90:150-165.

Jaenicke, R. and Rudolph, R. (1989). In: *Protein Structure, A Practical Approach*, edited by T.E. Creighton, pp. 191-223. IRL Press, Oxford.

Johnson, D.E., Lee, P., Lu, J., and Williams, L.T. (1990). Diverse forms of a receptor for acidic and basic fibroblast growth factors. *Mol. Cell. Biol.* **10**:4728-4736.

Johnson, D.E., Lu, J., Chen, H., Werner, S., and Williams, L.T. (1991). The human fibroblast growth factor receptor genes: a common structural arrangement underlies the mechanisms for generating receptor forms that differ in their third immunoglobulin domain. *Mol. Cell. Biol.* **11**:4627-4634.

Jonas, V., Lin, C.R., Kawashima, E., Semon, D., Swanson, L.W., Mermod, J-J., Evans, R.M., and Rosenfeld, M.G. (1985). Alternative RNA processing events in human calcitonin/calcitonin gene-related peptide gene expression. *Proc. Natl. Acad. Sci. U. S. A.* **82**:1994-1998.

Kar, N.C. and Pearson, C.M. (1977). Early elevation of cathepsin B1 in human muscle disease. *Biochem. Med.* **18**:126-129.

Kasafirek, K.E., Novak, K., and Viklicky, J. (1990). Increased cathepsin B activity in human lung tumors. *Neoplasma* **37**:61-70.

Kato, N. and Harada, F. (1985). New U1 RNA species found in friend SFFV (spleen focus forming virus)-transformed mouse cells. *J. Biol. Chem.* **260**:7775-7782.

Keppler, D., Fondaneche, M.C., Dalet-Fumeron, V., Parano, M., and Burtin, P. (1988a). Immunohistochemical and biochemical study of a cathepsin B-like proteinase in human colonic cancers. *Cancer Res.* **48**:6855-6862.

Keppler, D., Pagano, M., Dalet-Fumeron, V., and Engler, R. (1988b). Purification and characterization of two different precursor forms of the cathepsin B-like proteinase from human malignant ascitic fluid. *Biol. Chem. Hoppe-Sayler* **369 Suppl**:185-190.

Keren, Z. and LeGrue, S.J. (1988). Identification of cell surface cathepsin B-like activity on murine melanomas and fibrosarcomas: modulation by butanol extraction. *Cancer Res.* **48**:1416-1421.

Kim, S-J., Park, K., Koeller, D., Kim, K.Y., Wakefield, L.M., Sporn, M.B., and Roberts, A.B. (1992). Post-transcriptional regulation of the human transforming growth factor- β 1 gene. *J. Biol. Chem.* **267**:13702-13707.

- Kobayashi, H., Ohi, H., Sugimura, M., Shinohara, H., Fujii, T., and Terao, T. (1992). Inhibition of in vitro ovarian cancer cell invasion by modulation of urokinase-type plasminogen activator and cathepsin B. *Cancer Res.* **52**:3610-3614.
- Kobayashi, H., Schmitt, M., Goretzki, L., Chucholowski, N., Calvete, J., Kramer, M., Gunzler, W.A., Janicke, F., and Graeff, H. (1991). Cathepsin B efficiently activates the soluble and the tumor cell receptor-bound form of the proenzyme urokinase-type plasminogen activator (Pro-uPA). *J. Biol. Chem.* **266**:5147-5152.
- Koppel, P., Baici, A., Keist, R., Matzku, S., and Keller, R. (1984). Cathepsin B-like proteinase as marker for metastatic tumor cell variants. *Expl. Cell Biol.* **52**:293-299.
- Kornfeld, S. (1987). Trafficking of lysosomal enzymes. *FASEB J.* **1**:462-468.
- Kozak, M. (1986). Influences of mRNA secondary structure on initiation by eukaryotic ribosomes. *Proc. Natl. Acad. Sci. U. S. A.* **83**:2850-2854.
- Kozak, M. (1989). Circumstances and mechanisms of inhibition of translation by secondary structure in eucaryotic mRNAs. *Mol. Cell. Biol.* **9**:5134-5142.
- Kozak, M. (1991a). Structural features in eukaryotic mRNAs that modulate the initiation of translation. *J. Biol. Chem.* **266**:19867-19870.
- Kozak, M. (1991b). An analysis of vertebrate mRNA sequences; intimations of translational control. *J. Cell Biol.* **115**:887-903.
- Kozak, M. (1991c). Effects of long 5' leader sequences on initiation by eukaryotic ribosomes in vitro. *Gene Expression* **1**:117-125.
- Kozak, M. (1991d). A short leader sequence impairs the fidelity of initiation by eukaryotic ribosomes. *Gene Expression* **1**:111-115.
- Kozlowski, J.M., Fidler, I.J., Campbell, D., Xu, Z-L., Kaighn, E.M., and Hart, I.R. (1984). Metastatic behavior of human tumor cell lines grown in the nude mouse. *Cancer Res.* **44**:3522-3529.
- Krainer, A.R., Conway, G.C., and Kozak, D. (1990a). The essential pre-mRNA splicing factor SF2 influences 5' splice site selection by activating proximal sites. *Cell* **62**:35-42.

Krainer, A.R., Conway, G.C., and Kozak, D. (1990b). Purification and characterization of pre-mRNA splicing factor SF2 from Hela cells. *Genes Dev.* 4:1158-1171.

Krainer, A.R., Maniatis, T., Ruskin, B., and Green, M.R. (1984). Normal and mutant human β -globin pre-mRNAs are faithfully and efficiently spliced in vitro. *Cell* 36:993-1005.

Kramer, A., Keller, W., Appel, B., and Luhrmann, R. (1984). The 5' terminus of the RNA moiety of U1 small nuclear ribonucleoprotein particles is required for the splicing of messenger RNA precursors. *Cell* 38:299-307.

Kramer, P.H., Vogel, K.G., and Nicolson, G.L. (1986). Solubilization and degradation of subendothelial matrix glycoproteins and proteoglycans by metastatic tumor cells. *J. Biol. Chem.* 257:2678-2685.

Krof, G.M., Botros, I.W., and Stumph, W.E. (1988). Developmental and tissue specific expression of U4 small nuclear RNA genes. *Mol. Cell. Biol.* 8:5566-5569.

Kruys, V., Wathelet, M., Poupart, P., Contreras, R., Fiers, W., Content, T., and Huez, G. (1987). The 3' untranslated region of the human interferon-B mRNA has an inhibitory effect on translation. *Proc. Natl. Acad. Sci. U. S. A.* 84:6030-6034.

Kwiatkowski, D.J., Stossel, T.P., Orkin, S.H., Mole, J.E., Colten, H.R., and Yin, H.L. (1986). Plasma and cytoplasmic gelsolins are encoded by a single gene and contain a duplicated actin binding domain. *Nature* 323:455-458.

Laemmli, U.K. (1970). Cleavage of structural proteins during the assembly of the head of bacteriophage T4. *Nature* 227:680-685.

Lah, T.T., Kokalj-Kunovar, M., Drobnic-Kosorok, M., Babnik, J., Golouh, R., Vrhovec, I., and Turk, V. (1992). Cystatins and cathepsins in breast carcinoma. *Biol. Chem. Hoppe-Seyler* 373:595-604.

Lambowitz, A.W. (1989). Infectious introns. *Cell* 56:323-326.

Lamond, A.I., Konarska, M.M., and Sharp, P.A. (1987). A mutational analysis of spliceosome assembly: evidence for splice site collaboration during spliceosome formation. *Genes Dev.* 1:532-543.

Laskey, R.A. (1980). The use of intensifying screens or organic scintillators for visualizing radioactive molecules resolved by gel electrophoresis. *Meth. Enzymol.* 65:363-371.

- Laug, W.E., De Clerk, Y.A., and Jones, P.A. (1983). Degradation of the subendothelial matrix by tumor cells. *Cancer Res.* **43**:1827-1834.
- Leff, S.E., Evans, R.M., and Rosenfeld, M.G. (1987). Splice commitment dictates neuron-specific alternative RNA processing in calcitonin/CGRP gene expression. *Cell* **45**:517-524.
- Lerner, M.R., Boyle, J.A., Mount, S.M., Wolin, S.L., and Steitz, J.A. (1980). Are snRNPs involved in splicing? *Nature* **283**:220-224.
- LeStourgeon, W.M., Beyer, A.L., Christensen, M.E., Walker, B.W., Poupore, S.M., and Daniels, L.P. (1977). The packaging proteins of hnRNP particles and the maintenance of proliferative cell states. *Cold Spring Harbor Symp. Quant. Biol.* **42**:885-898.
- Leung, S., Whitelaw, E., and Proudfoot, N.J. (1989). Transcriptional and translational analysis of the human θ -globin gene. *Nucleic Acids Res.* **17**:8282-8300.
- Liang, L., Jetton, T.L., Zimmerman, E.C., Najafi, H., Matshinsky, F.M., and Magnuson, M.A. (1991). Effects of alternative RNA splicing on glucokinase isoform activities in the pancreatic islet, liver, and pituitary. *J. Biol. Chem.* **266**:6999-7007.
- Libri, D., Piseri, A., and Fiszman, M.Y. (1991). Tissue-specific splicing in vivo of the B-tropomyosin gene: dependence on an RNA secondary structure. *Science* **252**:1842-1845.
- Lillycrop, K.A. and Latchman, D.S. (1992). Alternative splicing of the Oct-2 transcriptional factor RNA is differentially regulated in neuronal cells and B cells and results in protein isoforms with opposite effects on the activity of octamer/TAATGARAT-containing promoters. *J. Biol. Chem.* **267**:24960-24965.
- Liotta, L.A., Abe, S., Roley, P.G., and Martin, G.R. (1979). Preferential digestion of basement membrane collagen by an enzyme derived from a metastatic murine tumor. *Proc. Natl. Acad. Sci. U. S. A.* **76**:2268-2272.
- Liotta, L.A., Thorgeirsson, V.P., and Garbisa, A. (1982). Role of collagenases in tumor invasion. *Cancer Metastasis Rev.* **1**:277-288.
- Lowe, W.L., Jr., Roberts, C.T., Jr., Lasky, S.R., and LeRoith, D. (1987). Differential expression of alternative 5' untranslated regions in mRNAs encoding rat insulin-like growth

- factor I. *Proc. Natl. Acad. Sci. U. S. A.* **84**:8946-8950.
- Lund, E. (1988). Heterogeneity of human U1 snRNAs. *Nucleic Acids Res.* **16**:5813-5826.
- Lund, E. and Dahlberg, J.E. (1987). Differential accumulation of U1 and U4 small nuclear RNAs during *Xenopus* development. *Genes Dev.* **1**:39-46.
- Lund, E., Kahan, B., and Dahlberg, J.E. (1985). Differential control of U1 small nuclear RNA expression during mouse development. *Science* **221**:1271-1274.
- Maciewicz, R.A., Wardale, R.J., Etherington, D.J., and Paraskeva, C. (1989). Immunodetection of cathepsin B and L present in and secreted from human premalignant and malignant colorectal tumor cell lines. *Int. J. Cancer* **43**:478-486.
- Mainferme, F., Wattiaux, R., and von Figura, K. (1985). Synthesis, transport and processing of cathepsin C in Morris hepatoma 7777 cells and rat hepacytes. *Eur. J. Biochem.* **153**:211-216.
- Maniatis, T., Fritsch, E.F., and Sambrook, J. (1987). Molecular cloning. A laboratory manual. Cold Spring Harbor Laboratory. Cold Spring Harbor.
- Manzella, J.M. and Blackshear, P.J. (1990). Regulation of rat ornithine decarboxylase mRNA translation by its 5'-untranslated region. *J. Biol. Chem.* **265**:11817-11822.
- Mason, R.W. (1989). Interaction of lysosomal cysteine proteinases with α 2-macroglobulin: conclusive evidence for endopeptidases of cathepsin B and H. *Arch. Biochem. Biophys.* **273**:467-374.
- Mathieu, M., Vignon, F., Capony, F., and Rochefort, H. (1991). Estradiol down-regulates the mannose-6-phosphate/insulin-like growth factor-II receptor gene and induces cathepsin-D in breast cancer cells: a receptor saturation mechanism to increase the secretion of lysosomal proenzymes. *Mol. Endocrinol.* **91**:815-822.
- Maudelonde, T., Khalaf, S., Garcia, M., Fress, G., Duporte, J., Benatia, M., Rogier, H., Paolucci, F., Simony, J., Pujol, H., Pau, B., and Rochefort, H. (1988). Immunoenzymatic assay of Mr 52,000 cathepsin D in 182 breast cancer cytosols. Low correlation with other prognostic parameters. *Cancer Res.* **48**:462-466.
- Mayeda, A. and Krainer, A.R. (1992). Regulation of alternative pre-mRNA splicing by hnRNP A1 and splicing factor SF2. *Cell*

68:365-375.

Mayeda, A. and Ohshima, Y. (1988). Short donor site sequences inserted within the intron of β -globin pre-mRNA serve for splicing in vitro. *Mol. Cell. Biol.* **8**:4484-4491.

Mayrand, S.H. and Pederson, T. (1990). Crosslinking of hnRNP proteins to pre-mRNA requires U1 and U2 snRNPs. *Nucleic Acids Res.* **18**:3307-3318.

McDonald, J.K. and Ellis, S. (1975). On the substrate specificity of cathepsin B1 and B2 including a new fluorogenic substrate for cathepsin B1. *Life Sci.* **17**:1269-1276.

Medford, R.M., Nguyen, H.T., Destree, A.T., Summers, E., and Nadal-Ginard, B. (1984). A novel mechanism of alternative RNA splicing for the developmentally regulated generation of troponin-T isoforms from a single gene. *Cell* **38**:409-421.

Melton, D.A., Krieg, P.A., Rebagliati, M.R., Maniatis, T., and Green, M.R. (1984). Efficient in vitro synthesis of biologically active RNA and RNA hybridization probes from plasmids containing a bacteriophage SP6 promoter. *Nucleic Acids Res.* **12**:7035-7056.

Moin, K., Rozhin, J., McKernan, T.B., Sanders, V.J., Fong, D., Honn, K.V., and Sloane, B.F. (1989). Enhanced levels of cathepsin B mRNA in murine tumors. *Febs Letters* **244**:61-64.

Morris, A.E., Kloss, B., McChesney, R.E., Bancroft, C., and Chasin, L.A. (1992). An alternatively spliced Pit-1 isoform altered in its ability to trans-activate. *Nucleic Acids Res.* **20**:1355-1361.

Mort, J.S., Leduc, M., and Recklies, A.D. (1981). A latent thiol proteinase from ascitic fluid of patient with neoplasia. *Biochim. Biophys. Acta* **662**:173-180.

Mort, J.S., Leduc, M.S., and Recklies, A.D. (1983). Characterization of a latent cysteine proteinase from ascitic fluid as a high molecular weight form of cathepsin B. *Biochim. Biophys. Acta* **755**:369-375.

Mort, J.S., Poole, A.R., and Decker, R.S. (1981). Immunofluorescent localization of the cathepsin B and D in the human fibroblasts. *J. Histochem. Cytochem.* **29**:649-657.

Mort, J.S. and Recklies, A.D. (1986). Interrelationship of active and latent secreted human cathepsin B precursor. *Biochem. J.* **233**:57-63.

Mort, J.S., Recklies, A.D., and Poole, A.R. (1980).

Characterization of a thiol proteinase secreted by malignant human breast tumors. *Biochim. Biophys. Acta* 614:134-143.

Moscatelli, D., Rifkin, D.B., Iseroff, R.R., and Jaffe, E.A. (1980). *Proteinases and tumor invasion*. Ravens Press, New York.

Mosley, B., Beckmann, M.P., March, C.J., Idzerda, R.L., Gimple, S.D., VandenBos, T., Friend, D., Alpert, A., Anderson, D., Jackson, J., Wignall, J.M., Smith, C., Gallis, B., Sims, J.E., Urdal, D., Widmer, M.B., Cosman, D., and Park, L.S. (1989). The murine interleukin-4 receptor: molecular cloning and characterization of secreted and membrane bound forms. *Cell* 59:335-348.

Mount, S.M. (1982). A catalogue of splice junction sequences. *Nucleic Acids Res.* 10:459-472.

Mueller, P.P. and Hinnebusch, A.G. (1986). Multiple upstream AUG codons mediate translational control of GCN4. *Cell* 45:201-297.

Mullins, D.E. and Rohrllich, S.T. (1983). The role of proteinases in cellular invasiveness. *Biochim. Biophys. Acta* 695:177-214.

Murnane, M.J., Sheahan, K., Ozdemirli, M., and Shuja, S. (1991). Stage-specific increases in cathepsin B messenger RNA content in human colorectal carcinoma. *Cancer Res.* 51:1137-1142.

Murray, M.B., Zilz, N.D., McCreary, N.L., MacDonald, M.J., and Towle, H.C. (1988). Isolation and characterization of rat cDNA clones for two distinct thyroid hormone receptors. *J. Biol. Chem.* 263:12770-12777.

Nishimura, Y., Amano, J., Sato, H., Tsuji, H., and Kato, K. (1988). Biosynthesis of lysosomal cathepsins B and H in cultured rat hepatocytes. *Arch. Biochem. Biophys.* 262:159-170.

Noble, J.C.S., Prives, C., and Menley, J.L. (1988). Alternative splicing of SV40 early pre-mRNA is determined by branch site selection. *Genes Dev.* 2:1460-1475.

Noguchi, T., Inoue, H., and Tunaka, T. (1986). The M1 and M2 type isozymes of rat pyruvate kinase are produced from the same gene by alternative RNA splicing. *J. Biol. Chem.* 261:13807-13812.

Nonaka, M., Ishikawa, N., Passwell, J., Natsuumesakai, S., and Colten, H.R. (1989). Tissue-specific initiation of murine

- complement factor B mRNA transcription. *J. Immunol.* **142**:1377-1382.
- Ohsawa, T., Higashi, T., and Tsuji, T. (1989). The secretion of high molecular weight cathepsin B from cultured human liver cancers. *Acta Medica Okayama* **43**:9-15.
- Ohshima, Y. and Gotoh, Y. (1987). Signals for the selection of a splice site in pre-mRNA. *J. Mol. Biol.* **195**:247-259.
- Ostrowski, L.E., Ahsan, A., Suthar, B.P., Pagast, P., Bain, D.L., Wong, C., Patel, A., and Schultz, R.M. (1986). Selective inhibition of proteolytic enzymes in an in vivo mouse model for experimental metastasis. *Cancer Res.* **46**:4121-4128.
- Otto, K. (1971). Tissue Proteinase. In: *Tissue Proteinases*, edited by A.J. Barrett, et al, pp. 1-28. Elsevier, New York.
- Padgett, R.A., Grobowski, P.J., Konarska, M.M., Seiler, S., and Sharp, P.A. (1986). Splicing of messenger RNA precursors. *Annu. Rev. Biochem.* **55**:1119-1150.
- Padgett, R.A., Konarska, M.M., Aebi, M., Hornig, H., Weissmann, C., and Sharp, P.A. (1985). Nonconsensus branch site sequences in the in vitro splicing of transcripts of mutant rabbit β -globin genes. *Proc. Natl. Acad. Sci. U. S. A.* **82**:8349-8353.
- Padgett, R.A., Mount, S.M., Steitz, J.A., and Sharp, P.A. (1983). Splicing of messenger RNA precursors is inhibited by antisera to small nuclear ribonucleoprotein. *Cell* **35**:101-107.
- Page, A.E., Warburton, M.J., Chambers, T.J., Pringle, J.A.S., and Hayman, A.R. (1992). Human osteoclastoma contain multiple forms of cathepsin B. *Biochim. Biophys. Acta* **1116**:57-66.
- Patton, J.G., Mayer, S.G., Tempst, P., and Nadal-Ginard, B. (1991). Characterization and molecular cloning of polypyrimidine tract-binding protein: a component of a complex necessary for pre-mRNA splicing. *Genes Dev.* **5**:1237-1251.
- Periasamy, M., Strehler, E.E., Garfinkel, L.I., Gubits, R.M., Ruiz-Opazo, N., and Nadal-Ginard, B. (1984). Fast skeletal muscle myosin light chains 1 and 3 are produced from a single gene by a combined process of differential RNA transcription and splicing. *J. Biol. Chem.* **259**:13595-13604.
- Persky, B., Ostrowski, L.E., Pagast, P., Ahsan, A., and Schultz, R.M. (1986). Inhibition of proteolytic enzymes in the in vitro amnion model for basement membrane invasion. *Cancer Res.* **46**:4129-4134.

Petrova-Skalkova, D., Krepela, E., Rasnick, D., and Vicar, J. (1987). A latent form of cathepsin B in pleural effusions. I. Characterization of the enzyme in breast cancer patients. *Biochem. Med. Met. Biol.* **38**:219-227.

Pietras, R.J. and Roberts, J.A. (1981). Cathepsin B-like enzyme: subcellular distribution and properties in neoplastic and control cells from human ectocervix. *J. Biol. Chem.* **256**:8536-8544.

Pietras, R.J., Seeler, B.J., and Szego, C.M. (1975). Influence of antidiuretic hormone on release of lysosomal hydrolase at mucosal surface of epithelial cells from urinary bladder. *Nature* **257**:493-495.

Pietras, R.J., Szego, C.M., Mangan, C.E., Seeler, B.J., and Burtnett, M.M. (1979). Elevated serum cathepsin B1-like activity in women with neoplastic disease. *Gynecol. Oncol.* **7**:1-17.

Planck, S.R., Listerud, M.D., and Buckley, S.D. (1988). Modulation of hnRNP A1 protein gene expression by epidermal growth factor in Rat-1 cells. *Nucleic Acids Res.* **16**:11663-11673.

Polgar, L. and Csoma, C. (1987). Dissociation of ionizing groups in the binding cleft inversely controls the endo- and exopeptidase activities of cathepsin B. *J. Biol. Chem.* **262**:14448-14459.

Poole, A.R., Tilman, K.J., Recklies, A.D., and Stocker, T.A.M. (1978). Differences in erection of the proteinase cathepsin B at the edges of human breast carcinomas and fibroadenomas. *Nature* **273**:545-547.

Pracht, V., Bajkowski, A.S., and Frankfater, A. (1991). Vacuolar pH and Cathepsin B secretion by BALA/3T3 fibroblasts and moloney murine sarcoma virus transformed BALB/3T3 fibroblasts. *FASEB J.* **5**:A1178.

Qian, F., Bajkowski, A.S., Steiner, D.F., Chan, S.J., and Frankfater, A. (1989). Expression of five cathepsins in murine melanoma of varying metastatic potential and normal tissues. *Cancer Res.* **49**:4870-4875.

Qian, F., Chan, S.J., Gong, Q., Bajkowski, A.S., Steiner, D.F., and Frankfater, A. (1991a). The expression of cathepsin B and other lysosomal proteinases in normal tissues and in tumors. *Biomed. Biochem. Acta* **50**:531-540.

Qian, F., Frankfater, A., Miller, R.V., Chan, S.J., and Steiner, D.F. (1990). Molecular cloning of rat precursor

cathepsin H and expression of five lysosomal cathepsins in normal tissues and in a rat carcinosarcoma. *Int. J. Biochem.* **22**:1457-1462.

Qian, F., Frankfater, A., Chan, S.J., and Steiner, D.F. (1991b). The structure of the mouse cathepsin B gene and its putative promoter. *DNA Cell Bio.* **10**:159-168.

Qian, F., Frankfater, A., Steiner, D.F., Bajkowski, A.S., and Chan, S.J. (1991c). Characterization of multiple cathepsin B mRNAs in murine B16 melanoma. *Anticancer Res.* **11**:1445-1452.

Quinn, P.S. and Judah, J.D. (1978). Calcium-dependent Golgi-vesicle fusion and cathepsin B in the conversion of proalbumin into albumin in rat liver. *Biochem. J.* **172**:301-309.

Rao, C.D., Pech, M., Robbins, K.C., and Aronson, S.A. (1988b). The 5' untranslated sequence of the c-sis/platelet-derived growth factor 2 transcript is a potent translational inhibitor. *Mol. Cell. Biol.* **8**:284-292.

Rawlings, N.D. and Barrett, A.J. (1990). Evolution of proteins of the cystatin superfamily. *J. Mol. Evol.* **30**:60-71.

Recklies, A.D., Mort, J.S., and Poole, A.R. (1982). Secretion of a thiol proteinase from mouse mammary carcinomas and its characterization. *Cancer Res.* **42**:1026-1032.

Recklies, A.D., Poole, A.R., and Mort, J.S. (1982). A cysteine proteinase secreted from human breast tumors is immunologically related to cathepsin B. *Biochem. J.* **207**:633-636.

Recklies, A.D., Tiltman, K.J., Stoker, T.A.M., and Poole, A.R. (1980). Secretion of proteinases from malignant and nonmalignant human breast tissue. *Cancer Res.* **40**:550-556.

Reed, R. and Maniatis, T. (1985). Intron sequences involved in lariat formation during pre-mRNA splicing. *Cell* **41**:95-105.

Reid, I.A., Morris, B.J., and Ganong, W.F. (1978). The renin-angiotensin system. *Annu. Rev. Physiol.* **40**:377-415.

Rogers, J., Early, P., Carter, C., Calame, K., Bond, M., Hood, L., and Wall, R. (1980). Two mRNAs with different 3' ends encode membrane-bound and secreted forms of immunoglobulin m chain. *Cell* **20**:303-312.

Ross, J. (1988). Messenger RNA turnover in eukaryotic cells. *Mol. Biol. Med.* **5**:1-4.

- Rowan, A.D., Mason, P., Mach, L., and Mort, J.S. (1992). Rat procathepsin B. *J. Biol. Chem.* **267**:15993-15999.
- Ruby, S.W. and Abelson, J. (1991). Pre-mRNA splicing in yeast. *Trends Genet.* **7**:79-85.
- Ruskin, B., Greene, J.M., and Green, M.R. (1985). Cryptic branch point activation allows accurate in vitro splicing of human β -globin intron mutants. *Cell* **41**:833-844.
- Ruskin, B., Krainer, A.R., Maniatis, T., and Green, M.R. (1984). Excision of an intact intron as a novel lariat structure during pre-mRNA splicing in vitro. *Cell* **38**:317-331.
- Russel, M., Kidd, S., and Kelley, M.R. (1986). Improved filamentous helper phage for generating single-stranded plasmid DNA. *Gene* **45**:333-338.
- Salditt-Georgieff, M., Harpold, M., and Chen-Kiang, S. (1980). The addition of 5' cap structure occurs early in hnRNA synthesis and prematurely terminated molecules are capped. *Cell* **19**:69-78.
- Saluja, A., Saluja, M., Villa, A., Leli, U., Rutledge, P., Meldolesi, J., and Steer, M. (1989). Pancreatic duct obstruction in rabbits causes digestive zymogen and lysosomal localization. *J. Clin. Invest.* **84**:1260-1266.
- Sanger, F., Nicklen, S., and Coulson, A.R. (1977). DNA sequencing with chain-terminating inhibitors. *Proc. Natl. Acad. Sci. U. S. A.* **74**:5463-5467.
- Sanke, T., Bell, G.I., Sample, C., Rubenstein, A.H., and Steiner, D.F. (1988). An islet amyloid peptide is derived from an 89-amino acid precursor by proteolytic processing. *J. Biol. Chem.* **263**:17343-17246.
- Schmitt, M., Janicke, F., Moniwa, N., Chucholowski, N., Pache, L., and Graeff, H. (1992). Tumor-associated urokinase-type plasminogen activator: biological and clinical significance. *Biol. Chem. Hoppe-Seyler* **373**:611-622
- Schwarz, T.L., Tempel, B.L., Papazian, D.M., Jan, Y.N., and Jan, L.Y. (1988). Multiple potassium-channel components are produced by alternative splicing at the shaker locus in *Drosophila*. *Nature* **331**:137-142.
- Schwarzbauer, J.E., Patel, R.S., Fonda, D., and Hynes, R.O. (1987). Multiple sites of alternative splicing of the rat fibronectin gene transcript. *EMBO J.* **6**:2573-2580.
- Setzer, D.R., McGrogan, M., Nunberg, J.H., and Schimke, R.T.

(1980). Size heterogeneity in the 3' end of dihydrofolate reductase messenger RNAs in mouse cells. *Cell* 22:361-370.

Shapiro, M.B. and Senapathy, P. (1987). RNA splice junctions of different classes of eukaryotes: statistics and functional implications in gene expression. *Nucleic Acids Res.* 15:7155-7174.

Sharp, P.A. (1987). Splicing of messenger RNA precursors. *Science* 235:766-771.

Shaw, E. and Dean, R.T. (1980). The inhibition of macrophage protein turnover by a selective inhibitor of thiol proteinases. *Biochem. J.* 186:385-390.

Shaw, G. and Kamen, R. (1986). A conserved AU sequence from the 3' untranslated region of GM-CSF mRNA mediates selective mRNA degradation. *Cell* 46:659-667.

Shaw, P., Sordat, B., and Schibler, U. (1985). The two promoters for the mouse α -amylase gene amy-1 are differentially activated during parotid gland differentiation. *Cell* 40:907-912.

Sheahan, K., Shuja, S., and Murnane, M.J. (1989). Cysteine proteinase activities and tumor development in human colorectal carcinoma. *Cancer Res.* 49:3809-3814.

Shen, S.J., Daimon, M., Wang, C-Y., Jansen, M., and Ilan, J. (1988). Isolation of an insulin-like growth factor II cDNA with a unique 5' untranslated region from human placenta. *Proc. Natl. Acad. Sci. U. S. A.* 85:1947-1951.

Sierakowska, H., Szer, W., Furdon, P.J., and Kole, R. (1986). Antibodies to hn RNP core proteins inhibit in vitro splicing of human β -globin pre-mRNA. *Nucleic Acids Res.* 14:5241-5254.

Sloane, B.F. (1990). Cathepsin B and cystatins: evidence for a role in cancer progression. *Seminars in Cancer Biology* 1:137-152.

Sloane, B.F., Dunn, J.R., and Honn, K.V. (1981). Lysosomal cathepsin B: correlation with metastatic potential. *Science* 212:1151-1153.

Sloane, B.F., Honn, K.V., Sadler, J.G., Turner, W.A., Kimpson, J.J., and Taylor, J.D. (1982). Cathepsin B activity in B16 melanoma cells: a possible marker for metastatic potential. *Cancer Res.* 42:980-986.

Sloane, B.F., Rozhin, J., Johnson, K., Taylor, H., Crissman, J.D., and Honn, K.V. (1986). Cathepsin B: association with

- plasma membrane in metastatic tumors. *Proc. Natl. Acad. Sci. U. S. A.* **83**:2483-2487.
- Sloane, B.F., Rozhin, J., Hatfield, J.S., Crissman, J.D., and Honn, K.V. (1987). Plasma membrane-associated cysteine proteinases in human and animal tumors. *Exp. Cell. Biol.* **55**:209-224.
- Smith, C.W.J. and Nadal-Ginard, B. (1989). Mutually exclusive splicing of α -tropomyosin exons enforced by an unusual lariat point location: implications for constitutive splicing. *Cell* **56**:749-758.
- Smith, C.W.J., Patton, J.G., and Nadal-Ginard, B. (1989). Alternative splicing in the control of gene expression. *Annu. Rev. Genet.* **23**:527-577.
- Solnick, D. (1985). Alternative splicing caused by RNA secondary structure. *Cell* **43**:667-676.
- Solnick, D. and Lee, S.I. (1987). Amount of RNA secondary structure required to induce an alternative splice. *Mol. Cell. Biol.* **7**:3194-3198.
- Swanson, M.S. and Dreyfuss, G. (1988). Classification and purification of proteins of heterogeneous nuclear ribonucleoprotein particles by RNA-binding specificities. *Mol. Cell. Biol.* **8**:2237-2241.
- Takaki, S., Tominaga, A., Hitoshi, Y., Mita, S., Sonoda, E., Yamaguschi, N., and Takatsu, K. (1990). Molecular cloning and expression of the murine interleukin-5 receptor. *EMBO J.* **9**:4367-4374.
- Takenaga, K. (1984). Enhanced metastatic potential of cloned low-metastatic Lewis lung carcinoma cells treated in vitro with dimethylsulfoxide. *Cancer Res.* **44**:1122-1127.
- Takio, K., Towatari, T., Katinuma, N., Teller, D.C., and Titani, K. (1983). Homology of amino acid sequences of rat liver cathepsins B and H with that of papain. *Proc. Natl. Acad. Sci. U. S. A.* **80**:3666-3670.
- Tchoupe, J.R., Moreau, T., Gauthier, F., and Bieth, J.G. (1991). Photometric or fluorometric assay of cathepsin B,L and H and papain using substrates with an aminotrifluoromethylcoumarin leaving group. *Biochim. Biophys. Acta* **1076**:149-151.
- Teruya, J.H., Kutsunai, S.Y., Spear, D.H., Edwards, P.A., and Clarke, C.F. (1990). Testis-specific transcription initiation sites of rat faresyl pyrophosphate synthetase mRNA. *Mol.*

Cell. Biol. 10:2315-2326.

Timpe, L.C., Schwarz, T.L., Tempel, B.L., Papazian, D.M., Jan, Y.N., and Jan, L.Y. (1988). Expression of functional potassium channels from shaker cDNA in *Xenopus* oocytes. *Nature* 331:143-145.

Tong, B.T., Auer, D.E., Jaye, M., Kaplow, J.M., and Ricca, G. (1987). cDNA clones reveal differences between human glial and endothelial cell platelet derived growth factor A-chains. *Nature* 328:619-621.

Topham, C.M., Overington, J., Kowlessur, D., Thomas, M., Thomas, E.W., and Brocklehurst, K. (1990). Investigation of mechanistic consequences of natural structural variation within the cysteine proteinases by knowledge-based modelling and kinetic methods. *Biochem. Soc. Trans.* 18:579-580.

Tosi, M., Young, R.A., Hagenbuchle, O., and Schibler, U. (1981). Multiple polyadenylation sites in a mouse α -amylase gene. *Nucleic Acids Res.* 9:2313-2323.

Treiman, R., Orkin, S.H., and Maniatis, T. (1983). Specific transcription and RNA splicing defects in five cloned β -thalassemia genes. *Nature* 302:591-596.

Troen, B.R., Ascherman, D., Atlas, D., and Gottesman, M.M. (1988). Cloning and expression of the gene for the major excreted protein of transformed mouse fibroblasts. A secreted lysosomal protease regulated by transformation. *J. Biol. Chem.* 263:251-261.

Tsurushita, N., Ho, L., and Korn, L.J. (1988). Nuclear factors in B-lymphoma enhance splicing of mouse membrane bound m-mRNA in *Xenopus* oocytes. *Science* 239:494-497.

Vinson, C.R., LaMarco, K.L., Johnson, P.F., Landschulz, W.H., and McKnought, S.L. (1988). In situ detection of sequence-specific DNA binding activity specified by a recombinant bacteriophage. *Genes Dev.* 2:801-806.

Walsh, C. (1979). *Enzymatic Reaction Mechanisms*. W.H. Freeman and Company, San Francisco.

Watanabe, M., Higashi, T., Watanabe, A., Osawa, T., Sato, Y., Kimura, Y., Tominaga, S., Hashimoto, N., Yoshida, Y., Morimoto, S. (1989). Cathepsin B and L activities in gastric cancer tissue: correlation with histological findings. *Biochem. Med. Met. Biol.* 42:21-29.

Waterhouse, P., Khokha, R., and Denhardt, T. (1990). Modulation of translation by the 5' leader sequence of the

mRNA encoding murine tissue inhibitor of metalloproteinases. *J. Biol. Chem.* **265**:5585-5589.

Weinberg, A.D. and Swain, S.L. (1990). IL-2 receptor (Tac antigen) protein expression is down-regulated by the 5'-untranslated region of the mRNA. *J. Immunol.* **144**:4712-4720.

Weiss, R.E., Liu, B.C., Ahlering, T., Dubeau, L., and Droller, M.J. (1990). Mechanisms of human bladder tumor invasion: role of protease cathepsin B. *J. Urology* **144**:798-804.

Wieczorek, D., Smith, C.W.J., and Nadal-Ginard, B. (1988). The rat α -tropomyosin gene generates a minimum of six different mRNAs coding for striated, smooth and non-muscle isoforms by alternative splicing. *Mol. Cell. Biol.* **8**:679-694.

Wiederander, B. and Kirschke, H. (1986). Antibodies to rat liver cathepsins: characterization and use for the identification of enzyme precursors. *Biomed. Biochem. Acta* **45**:1421-1431.

Woppman, A., Rinke, J., and Luhrmann, R. (1988). Direct cross-linking of snRNP protein F and 70K to snRNAs by ultraviolet radiation in situ. *Nucleic Acids Res.* **16**:10985-11004.

Yee, C. and Shiu, R.P.C. (1980). Invasion of reconstituted basement matrix by metastatic human tumor cells. *Cancer Res.* **46**:1980-1989.

Young, J.C., Gishizky, M.L., and Witte, O.N. (1991). Hyperexpression of interleukin-7 is not necessary or sufficient for transformation of a pre-B lymphoid cell line. *Mol. Cell. Biol.* **11**:854-863.

Young, R.A., Hagenbuckle, O., and Schibler, U. (1981). A single mouse α -amylase gene specifies two different tissue-specific mRNAs. *Cell* **23**:451-458.

Zardi, L., Carnemolla, B., Siri, A., Petersen, T.E., Paoletta, G., Sebastio, G., and Baralle, E.F. (1987). Transformed human cells produce a new fibronectin isoform by preferential alternative splicing of a previously unobserved exon. *EMBO J.* **6**:2337-2342.

Zhuang, Y., Leung, H., and Weiner, A.M. (1987). The natural 5' splice site of simian virus 40 large T antigen can be improved by increasing the base complementary to U1 RNA. *Mol. Cell. Biol.* **7**:3018-3020.

Zucker, S., Lysik, R.M., Wieman, J., Wilkie, P.D., and Lane,

B. (1985). Diversity of human pancreatic cancer cell proteinases: role of cell membrane metalloproteinases in collagenolysis and cytolysis. *Cancer Res.* 45:6168-6178.

APPROVAL SHEET

The dissertation submitted by Qiuming Gong has been read and approved by the following committee:

Dr. Allen Frankfater (Dissertation Director)
Associate Professor, Biochemistry, Loyola University.

Dr. Richard M. Schultz
Professor, Biochemistry, Loyola University.

Dr. Mark R. Kelley
Assistant Professor, Biochemistry, Loyola University.

Dr. Sally A. Amero
Assistant Professor, Biochemistry, Loyola University.

Dr. Gary L. Engelmann
Associate Professor, Medicine, Loyola University.

Dr. Russell Pieper
Assistant Professor, Hematology/Oncology, Loyola University.

The final copies have been examined by the director of the dissertation and the signature which appears below verifies the fact that any necessary changes have been incorporated and that the dissertation is now given final approval by the committee with reference to content and form.

The dissertation is therefore accepted in partial fulfillment of the requirements for the degree of Doctor of Philosophy.

Sept 9, 1993
Date

Allen Frankfater
Director's signature