

## Design of a Novel X-band Slotted Waveguide Antenna Array with TE<sub>20</sub> Mode Feeding

Mohamed Elhefnawy

Department of Electrical Engineering, Faculty of Engineering, October 6 University, Egypt

[mmmelhefnawy.eng@o6u.edu.eg](mailto:mmmelhefnawy.eng@o6u.edu.eg)

Received : 22/11/2018

Accepted : 15/01/2019

**ABSTRACT-** The Slotted Waveguide Antenna Array (SWAA) was introduced since the decade of 40s. This type of antenna array is well known by its reliability and ability to handle large amounts of power and high operating frequencies, so that the SWAA is commonly used as a part of radar systems. This research paper studies the design of a novel X-band Slotted Waveguide Antenna Array (SWAA) which is excited by TE<sub>20</sub> mode. The radiation characteristics of TE<sub>20</sub> mode excited SWAA are compared with conventionally designed TE<sub>10</sub> mode excited SWAA. The CST Microwave Studio (CST MWS) simulation results show that the SWAA with TE<sub>20</sub> mode feeding features high bandwidth, narrow beamwidth, and high gain as compared with TE<sub>10</sub> mode fed SWAA. Feeding the SWAA by using TE<sub>20</sub> mode instead of TE<sub>10</sub> mode results in increasing the bandwidth by 5.7 %, decreasing the beamwidth by 30°, and improving the antenna array gain by 2.2 dBi higher than the obtained gain with TE<sub>10</sub> mode feeding.

*Keywords: Slot antenna, Rectangular waveguide, Antenna array, Babinet's principle.*

المستخلص - تم التعرف على مصفوفة هوائيات دليل الموجة ذات الفتحات منذ عقد الأربعينات. هذا النوع من مصفوفة الهوائيات معروف جيداً بموثوقيته وقدرته على التعامل مع كميات كبيرة من الطاقة و ترددات التشغيل العالية، و لذلك تستخدم هذه المصفوفة على نطاق واسع مع أنظمة الرادار. تدرس هذه الورقة البحثية تصميم مبتكر لمصفوفة هوائيات دليل الموجة ذات الفتحات و التي تعمل في الحيز الترددي *X-band* و يتم تغذيتها بنمط *TE<sub>20</sub>*. يتم مقارنة خصائص الإشعاع لمصفوفة الهوائيات المقترحة في حالة التغذية بنمط *TE<sub>20</sub>* مع خصائص الإشعاع لنفس مصفوفة الهوائيات عند تغذيتها بالطريقة التقليدية بنمط *TE<sub>10</sub>*. نتائج المحاكاة باستخدام برنامج التصميم *CST MWS* تظهر أن تغذية مصفوفة الهوائيات المقترحة بنمط *TE<sub>20</sub>* يسبب سعة في عرض النطاق الترددي، و ضيق في عرض زاوية الإشعاع، و الحصول على كسب مرتفع بالمقارنة مع نفس مصفوفة الهوائيات ذات التغذية التقليدية بنمط *TE<sub>10</sub>*. تغذية مصفوفة هوائيات دليل الموجة ذات الفتحات باستخدام نمط *TE<sub>20</sub>* بدلاً من نمط *TE<sub>10</sub>* يؤدي إلى زيادة عرض النطاق الترددي بنسبة 5.7 %، و تقليل عرض زاوية الإشعاع بمقدار 30°، و تحسين كسب مصفوفة الهوائيات بمقدار 2.2 ديسيبل أعلى من الكسب الذي تم الحصول عليه عند التغذية بنمط *TE<sub>10</sub>*.

### INTRODUCTION

The waveguide slot antennas are low-loss, high power capability, low-profile and can be conformed to basically any configuration, thus they have found many radar systems applications especially in Synthetic Aperture Radar (SAR) systems [1-4]. A slot antenna was introduced by Booker in 1946 [5]. Later, slotted waveguide antenna was conducted by Watson [6]. Oliner in 1957 was able to analyze the slotted waveguide antenna based on its equivalence circuit [7] [8]. The theory behind designing the slotted waveguide antenna array was presented by Elliott in 1982 [9].

In this paper, the design procedure and numerical simulator of resonant or standing wave slotted waveguide antenna are presented. For TE<sub>10</sub> and TE<sub>20</sub> excitation modes, the SWAA is fed at distance of a quarter waveguide wavelength from short circuited one end of the waveguide, and the other end of the waveguide is also terminated by a short circuit, where the slot antennas can be excited by the generated standing wave inside the waveguide with short circuit ends. The electromagnetic radiation of the slotted waveguide antenna array is stronger than single slot case. In optics, the Babinet's principle states that the summation of field behind a screen with an

opening and the field behind a complementary structure is equal to the field when there is no screen. Babinet's principle has been extended by Booker to include radio waves [5]. The radiated fields of slot and dipole antennas are related to each other based on this principle. The radiation pattern of a slot antenna is identical to that of the complementary metallic dipole strip which fits the slot opening. The difference is that the orientation of the electric and magnetic fields is exchanged. For a slot antenna, if it is aligned parallel to z-axis, the electric field is  $\phi$  directed while the electric field for its complementary dipole is  $\theta$  directed [10] [11]. This paper aims to improve the radiation characteristics of the SWAA which is commonly implemented with the microwave radar systems. The proposed SWAA with TE<sub>10</sub> and TE<sub>20</sub> excitation modes has been designed, and then simulated using CST MWS. The radiation characteristics of the proposed X-band SWAA with TE<sub>20</sub> mode are obtained to demonstrate the enhancement of the antenna gain, bandwidth, and power handling capacity to meet the requirements for X-band radar systems. To the best of our knowledge, this is the first research to study the effect of the excitation mode on the performance of the SWAA.

### Design of the SWAA

For the resonating vertically polarized SWAA as shown in Figure 1, the longitudinal slots in the broad wall are located at opposite sides to the central line in order to add phase shift of  $\pi$  in the neighboring slot fields. The equiphased radiation from the slots is  $\Delta\phi_v = \frac{2\pi}{\lambda_g} \frac{\lambda_g}{2} + \pi = 2\pi$ , so that the radiation from the neighboring slot will be in phase, where  $\lambda_g$  is the waveguide wavelength at the operating frequency. The distance between the centers of neighboring slots as well as the distance between the last slot center and the waveguide shorted end, also the dimension and offset of the slot are crucial to get the required radiation pattern. The radiation characteristics of the SWAA depend on the distance between the neighboring slots which determines the phase difference between the electromagnetic fields in the slots [12-16].

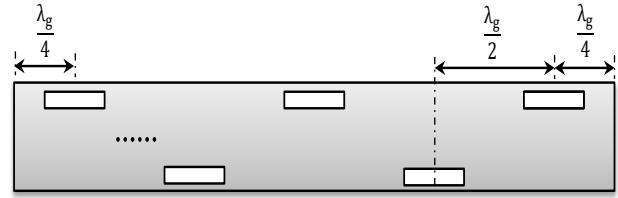

**Fig. 1. Structure of the resonating vertically polarized SWAA.**

The design procedures can be summarized as follows: firstly, choose the number of slots required for the desired gain; where the gain of the slot antenna array is estimated using the following formulas [17]

$$Gain = 10 \log \left[ \frac{N \frac{\lambda_g}{2}}{\lambda} \right] dBi$$

Where N is the number of slots along the waveguide. Secondly, choose a waveguide dimensions appropriate for operating frequency. For slotted waveguide antenna array which is excited by TE<sub>10</sub> mode, the width of the rectangular waveguide's wide-wall (a) is selected to make the operating frequency more than 15% above the cut-off frequency of the dominant mode. While in case of exciting the slotted waveguide antenna array with TE<sub>20</sub> mode, the width of the rectangular waveguide's wide-wall (a) is designed to make the operating frequency more than 15 % above the cut-off frequency of TE<sub>20</sub> mode. The narrow-wall width of the rectangular waveguide (b) is selected to be half the broad-wall width. The waveguide wavelength ( $\lambda_g$ ) is calculated as  $\lambda_g = \frac{1}{\sqrt{\frac{1}{\lambda^2} - \frac{1}{\lambda_c^2}}}$ ,

where  $\lambda_c$  is the cutoff wavelength at the operating mode, and  $\lambda$  is the free space wavelength [17]. Thirdly, determine the length, width and offset for the slot at the operating frequency; where slot length =  $\lambda/2$  and the slot width =  $\lambda/20$  at the wavelength  $\lambda = c / f$ , c and f are the speed of light and frequency of operation, respectively. The offset of slot from the central longitudinal line has been determined using CST MWS numerical calculations. Finally, a SEMI-RIGID CABLE .250 is used to feed the rectangular waveguide [18]. Wings are added to the SWAA to enlarge the ground plane for the slots and reduce the amount

of backward energy that may wrap around the SWAA.

**Simulation Results**

The array was designed with a total number of 64 identical slots, on one wide side of a rectangular waveguide’s wall. CST MWS software has been used to simulate the SWAA dimensions at operating frequency of 9.6 GHz in case of implementing TE<sub>10</sub> or TE<sub>20</sub> mode excitation. The SWAA dimensions are indicated in Table I.

TABLE I. SWAA DIMENSIONS

Parameter	SWAA Dimensions in mm	
	TE <sub>10</sub> mode excitation	TE <sub>20</sub> mode excitation
Wavelength in the waveguide $\lambda_g$	43	52
Width of the rectangular waveguide’s wide-wall	18	36
Width of the rectangular waveguide’s narrow-wall	9	18
Wavelength $\lambda$	31.2	29.54
Slot length	15.625	15.625
Slot width	0.893	0.893
Slot offset from the central longitudinal line	6.25	5.9
Wing width	10.75	13

The perspective, and bottom views of the SWAA with 64-slot are shown in Figures (2. a) and (2. b), respectively. Figure 2.c shows the cutting plane view of SWAA with 64-slot. The CST MWS simulations results for the reflection coefficients, elevation plane pattern and three dimensional radiation pattern for that slotted waveguide structure are shown in Figures (3), (4), and (5), respectively. The cross-section dimensions of the rectangular waveguide are (36 mm × 18 mm) as shown in Figure (6.a), while the cross-section dimensions of the rectangular waveguide shown in Figure (2.a) are (36 mm × 9 mm). The cross-section of the TE<sub>20</sub> mode fed SWAA with 64-slot is larger compared to the TE<sub>10</sub> mode fed SWAA with 64-slot; so that the power handling capability is much higher in case of implementing the SWAA with TE<sub>20</sub> excitation mode. Figures (6.b) and (6.c) show that the two inner conductors of the coaxial cables behave like two monopole antennas

to create an electric field and excite the TE<sub>20</sub> modes in the whole cross-section of the SWAA. Figures (2.b) and (2.c) show that the whole cross-section of the TE<sub>10</sub> mode fed SWAA with 64-slot is separated by a metal wall into two identical SWAA with 32-slot. Each 32-slot SWAA has a cross-section dimension of (18 mm × 9 mm), and is fed by an inner conductor of a coaxial cable which behaves like a monopole antenna to excite a separate TE<sub>10</sub> mode inside each 32-slot SWAA.

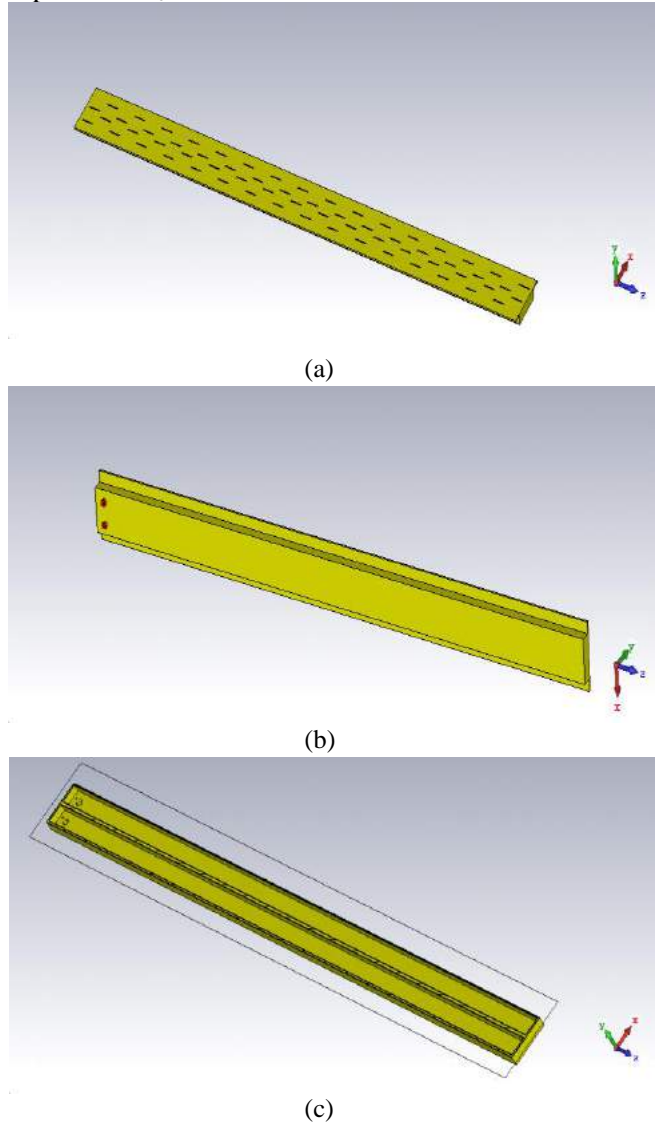

Fig. 2. CST MWS model for TE<sub>10</sub> mode fed SWAA with 64-slot (a) Perspective view (b) Bottom view (c) Cutting plane view.

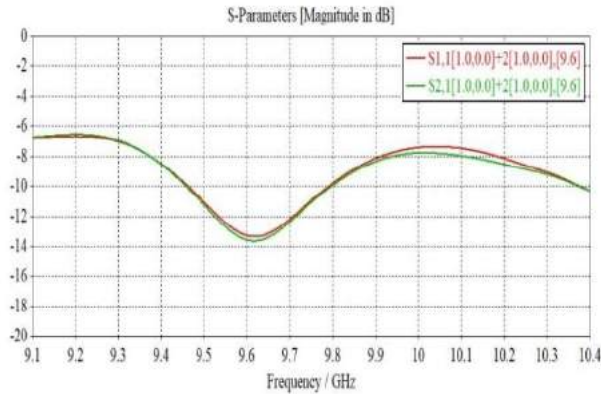

Fig. 3. Simulated S-parameters for TE<sub>10</sub> mode fed SWAA with 64-slot.

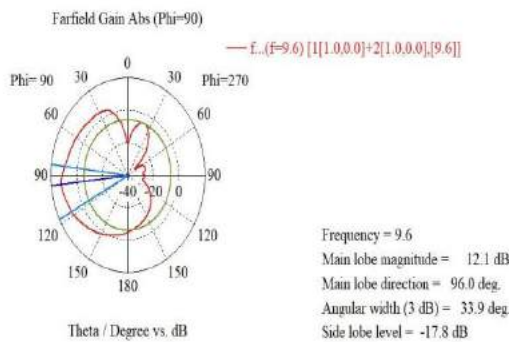

Fig. 4. YZ-plane pattern for TE<sub>10</sub> mode fed SWAA with 64-slot.

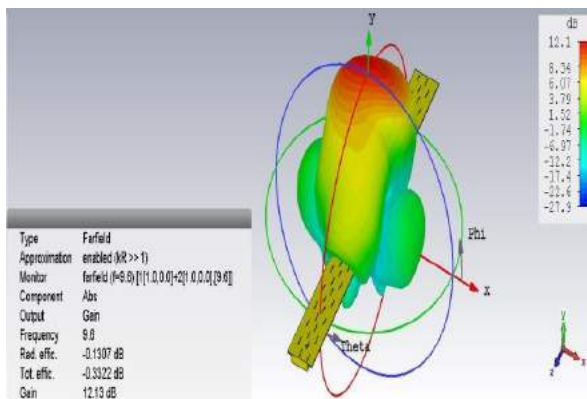

Fig. 5. Three-dimensional radiation pattern for TE<sub>10</sub> mode fed SWAA with 64-slot.

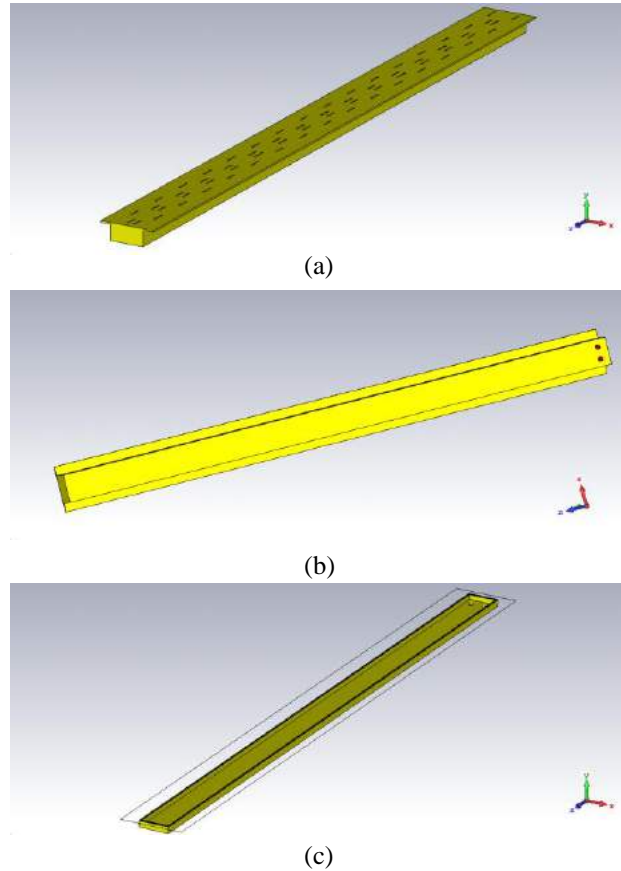

Fig. 6. CST MWS model for TE<sub>20</sub> mode fed SWAA with 64-slot (a) Perspective view (b) Bottom view (c) Cutting view.

In case of TE<sub>20</sub> mode fed SWAA with 64-slot, the bandwidth is about 9.3% compared to 3.6% for the TE<sub>10</sub> mode fed SWAA with 64-slot as shown in Figures (7) and (3). A comparison between the simulated S-parameters for TE<sub>20</sub> mode fed SWAA with 64-slot (solid red curves) and S-parameters for TE<sub>10</sub> mode fed SWAA with 64-slot (dashed blue curves) is indicated in Figure (8). Figures (9) and (10) show a CST simulation results for the elevation plane pattern and three dimensional radiation pattern, respectively. Also Figures (9) and (4) show that TE<sub>20</sub> mode fed SWAA with 64-slot provides a 3-dB beamwidth of 3.9 degrees in the elevation plane, while TE<sub>10</sub> mode fed SWAA with 64-slot achieves a 3-dB beamwidth of 33.9 degrees in the elevation plane. The CST simulation results which are shown in Figures (10) and (5) indicate that a gain of 14.33 dBi, and



radiation efficiency of 97.8% are obtained by using the TE<sub>20</sub> mode fed SWAA with 64-slot, while the TE<sub>10</sub> mode fed SWAA with 64-slot provides a gain of 12.13 dBi and radiation efficiency of 97%. When the antenna array has a narrower beamwidth, its ability to concentrate the power will be increased, and the antenna gain will be improved. The SWAA with TE<sub>20</sub> mode feeding has a narrower beamwidth as depicted in Figures (9) and (4), so that its gain is enhanced up to 2.2 dBi higher than the obtained gain with TE<sub>10</sub> mode feeding.

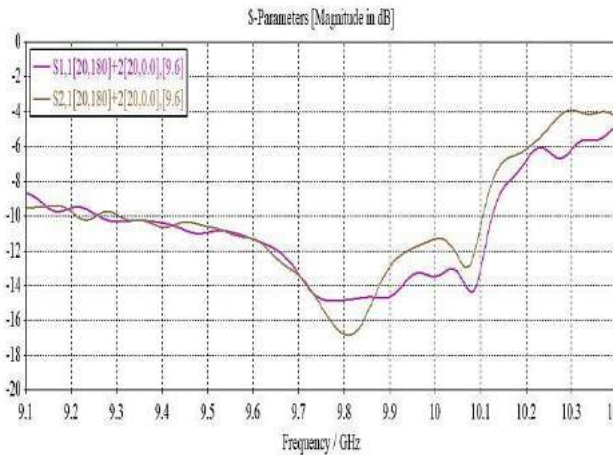

Fig. 7. Simulated S-parameters for TE<sub>20</sub> mode fed SWAA with 64-slot.

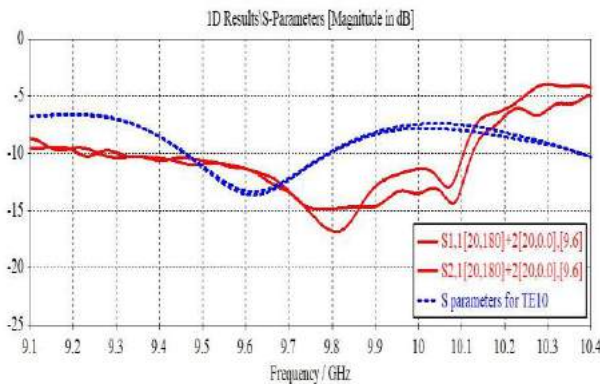

Fig. 8. Comparison between simulated S-parameters for TE<sub>20</sub> and TE<sub>10</sub> excitation modes fed SWAA with 64-slot.

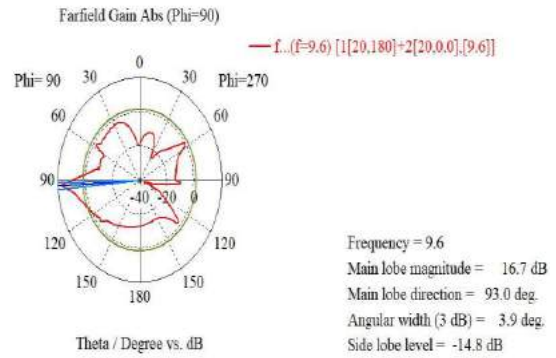

Fig. 9. YZ-plane radiation pattern for TE<sub>20</sub> mode fed SWAA with 64-slot.

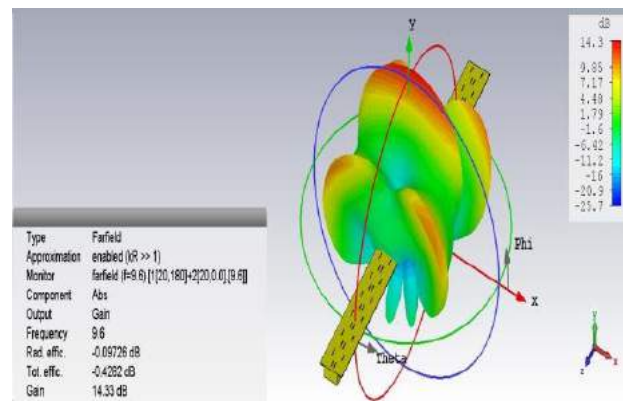

Fig. 10. Three-dimensional radiation pattern for TE<sub>20</sub> mode fed SWAA with 64-slot.

**CONCLUSION**

In this paper, TE<sub>20</sub> mode is proposed to feed the SWAA. The radiation characteristics of the SWAA can be improved by using TE<sub>20</sub> excitation mode. The CST MWS simulation results show that TE<sub>20</sub> mode fed SWAA with 64-slot can achieve a maximum antenna array gain of 14.33 dBi, a bandwidth of 9.3%, a beamwidth of 3.9 degrees in the elevation plane, and a radiation efficiency of 97.8% compared to a traditional TE<sub>10</sub> mode fed SWAA with 64-slot which can provide a maximum antenna array gain of 12.13 dBi, a bandwidth of 3.6%, a beamwidth of 33.9 degrees in the elevation plane, and a radiation efficiency of 97%. TE<sub>20</sub> mode fed SWAA is a good candidate for many applications which require a high power capability, narrow beamwidth, wide bandwidth, and high antenna array gain.

**REFERENCES:**

- [1] Y. Xiaole, N. Daning, L. Shaodong, Li Zhengjun and W. Wutu, "Design of a Wideband Waveguide Slot Array Antenna and its Decoupling Method for Synthetic Aperture Radar," 2008 38th European Microwave Conference, Amsterdam, 2008, pp. 135-138.
- [2] H. C. Zhao, R. R. Xu and W. Wu, "Broadband waveguide slot array for SAR," in *Electronics Letters*, vol. 47, no. 2, pp. 76-77, January 2011.
- [3] P. R. Akbar, H. Saito, M. Zhang, J. Hirokawa and M. Ando, "Parallel-Plate Slot Array Antenna for Deployable SAR Antenna Onboard Small Satellite," in *IEEE Transactions on Antennas and Propagation*, vol. 64, no. 5, pp. 1661-1671, May 2016.
- [4] S. S. Sekretarov and D. M. Vavriv, "A wideband slotted waveguide antenna for SAR systems," 2009 European Microwave Conference (EuMC), Rome, 2009, pp. 232-235.
- [5] H. G. Booker, "Slot aeriels and their relation to complementary wire aeriels (Babinet's principle)," in *Electrical Engineers - Part IIIA: Radiolocation*, Journal of the Institution of, vol. 93, no. 4, pp. 620-626, 1946.
- [6] W. H. Watson, "Resonant slots," in *Electrical Engineers - Part IIIA: Radiolocation*, Journal of the Institution of, vol. 93, no. 1, pp. 67-68, 1946.
- [7] A. Oliner, "The impedance properties of narrow radiating slots in the broad face of rectangular waveguide: Part I--Theory," in *IRE Transactions on Antennas and Propagation*, vol. 5, no. 1, pp. 4-11, January 1957.
- [8] A. Oliner, "The impedance properties of narrow radiating slots in the broad face of rectangular waveguide: Part II--Comparison with measurement," in *IRE Transactions on Antennas and Propagation*, vol. 5, no. 1, pp. 12-20, January 1957.
- [9] M. Orefice and R. S. Elliott, "Design of waveguide-fed series slot arrays," in *Microwaves, Optics and Antennas*, IEE Proceedings H, vol. 129, no. 4, pp. 165-169, August 1982.
- [10] Balanis, Constantine A. *Antenna Theory Analysis and Design*, Third ed., Wiley, 2005.
- [11] Jin, Jian-Ming. *Theory and Computation of Electromagnetic Fields*. IEEE Press, 2015.
- [12] Y. Tyagi, P. Mevada, S. Chakrabarty and R. Jyoti, "High-efficiency broadband slotted waveguide array antenna," in *IET Microwaves, Antennas & Propagation*, vol. 11, no. 10, pp. 1401-1408, 8 16 2017.
- [13] Y. E. Yamac and A. Kizilay, "A Waveguide Slot Array antenna design for X-band radar," 2016 9th International Kharkiv Symposium on Physics and Engineering of Microwaves, Millimeter and Submillimeter Waves (MSMW), Kharkiv, 2016, pp. 1-5.
- [14] H. M. El Misilmani, M. Al-Husseini, K. Y. Kabalan and A. El-Hajj, "A design procedure for slotted waveguide antennas with specified sidelobe levels," 2014 International Conference on High Performance Computing & Simulation (HPCS), Bologna, 2014, pp. 828-832.
- [15] A. Asrokin, N. Jamlus, D. M. Alias and A. K. Samingan, "Design & development of 10GHz slotted waveguide antenna," 2012 IEEE Asia-Pacific Conference on Applied Electromagnetics (APACE), Melaka, 2012, pp. 331-333.
- [16] F. Qingyuan, S. Lizhong and J. Ming, "Design and simulation of a waveguide slot antenna," *Proceedings of 2012 5th Global Symposium on Millimeter-Waves*, Harbin, 2012, pp. 131-134.
- [17] S. Rozenberg and A. Yahalom, "A THz Slot Antenna Optimization using Analytical Techniques," *RADIOENGINEERING*, vol. 25, no. 1. Sep. 2016.
- [18] Radiall.com. (2018). [online] Available at: <https://www.radiall.com/media/files/RFCableAssemblies%20D1C004XEe.pdf> [Accessed 7 Feb. 2018].