

Accepted Manuscript

A new boundary-based morphological model

Rubén Sarabia-Pérez, Antonio Jimeno- Morenilla, Rafael Molina-Carmona

PII: S0307-904X(14)00427-2
DOI: <http://dx.doi.org/10.1016/j.apm.2014.09.002>
Reference: APM 10116

To appear in: *Appl. Math. Modelling*

Received Date: 7 February 2013
Revised Date: 28 March 2014
Accepted Date: 1 September 2014

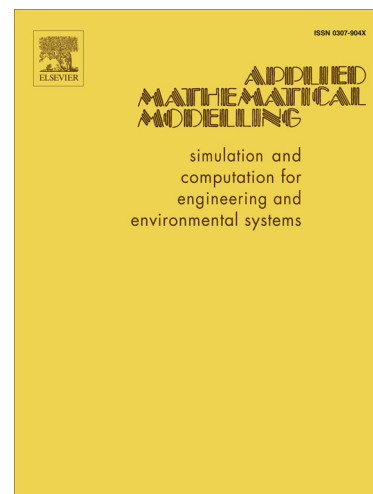

Please cite this article as: R. Sarabia-Pérez, A.J. Morenilla, R. Molina-Carmona, A new boundary-based morphological model, *Appl. Math. Modelling* (2014), doi: <http://dx.doi.org/10.1016/j.apm.2014.09.002>

This is a PDF file of an unedited manuscript that has been accepted for publication. As a service to our customers we are providing this early version of the manuscript. The manuscript will undergo copyediting, typesetting, and review of the resulting proof before it is published in its final form. Please note that during the production process errors may be discovered which could affect the content, and all legal disclaimers that apply to the journal pertain.

A new boundary-based morphological model

Rubén Sarabia-Pérez^a, Antonio Jimeno-Morenilla^a, Rafael Molina-Carmona^{b*}
rsp1@alu.ua.es, jimeno@dtic.ua.es, rmolina@dccia.ua.es

a Department of Computer Technology
University of Alicante
Apdo. Correos 99
03080 Alicante, Spain.

b Department of Computer Science and Artificial Intelligence
University of Alicante
Apdo. Correos 99
03080 Alicante, Spain.

*Corresponding author. Phone: (+34) 965 90 39 00 Fax: (+34) 965 90 39 02

Abstract

Mathematical morphology addresses the problem of describing shapes in an n-dimensional space using the concepts of set theory. A series of standardized morphological operations are defined, and they are applied to the shapes to transform them using another shape called the structuring element.

In an industrial environment, the process of manufacturing a piece is based on the manipulation of a primitive object via contact with a tool that transforms the object progressively to obtain the desired design. The analogy with the morphological operation of erosion is obvious. Nevertheless, few references about the relation between the morphological operations and the process of design and manufacturing can be found. The non-deterministic nature of classic mathematical morphology makes it very difficult to adapt their basic operations to the dynamics of concepts such as the ordered trajectory.

A new geometric model is presented, inspired by the classic morphological paradigm, which can define objects and apply morphological operations that transform these objects. The model specializes in classic morphological operations, providing them with the determinism inherent in dynamic processes that require an order of application, as is the case for designing and manufacturing objects in professional computer-aided design and manufacturing (CAD/CAM) environments. The operators are boundary-based so that only the points in the frontier are handled. As a consequence, the process is more efficient and more suitable for use in CAD/CAM systems.

Keywords: Mathematical morphology; Geometric model; Boundary-based morphology; Deterministic morphology

ACCEPTED MANUSCRIPT

1 Introduction

The continuous evolution of industrial technology has led to an increase in the quality of manufactured products. Computer-aided design and manufacturing (CAD/CAM) systems are now fundamental elements of the industry and are evolving at the same time as technology. Nevertheless, some problems still remain partially unsolved. Included among such problems is the complex problem of machining a piece using a tool. Although it is a problem that has been examined from many points of view with good results, it is still a complex problem that requires a very good knowledge of the problem and the use of ad-hoc techniques in many cases. A more general and formal mathematical model would be desirable.

The problem of machining a piece can be defined as a process of cutting a piece of material using a tool that moves according to a specific trajectory. A straightforward analogy can be established between the machining process and the formal concept of morphological erosion. The machining process can be interpreted as a morphological operation in which the structuring element (the tool) touches the target object (the manufactured piece), following a given direction. The process can also be likened to the design of an object, establishing a similar analogy when speaking of design tools and objects. Overall, we propose a definition of a morphological model to support the processes of machining and designing, attempting to establish both a generic formal model and a practical set of methods to solve real problems.

A short dissertation about mathematical morphology is now mandatory. Morphology is the study of shape, and mathematical morphology (MM) is mostly related to the mathematical theory of describing shapes using sets. It was first stated in 1964 when scientists Georges Matheron and Jean Serra applied the fundamental ideas of Minkowsky and Hadwiger to their studies on quantification of characteristics of minerals (Serra, 1982). Later, Jean Serra made a generalization of mathematical morphology in a theoretical framework based on complete lattices (full set of points arranged with upper bound, supremum, and lower bound, infimum). This generalization brought flexibility to the theory, which meant that it could be applied to a larger number of structures and fields of application (Serra, 1988).

MM is based on set theory, with some elements from topology, geometry and discrete mathematics. The sets represent shapes in an n -dimensional space. A series of standardized morphological operations are applied to these sets. These operations are based on geometric relationships between the points of the sets. The aim of the morphological operations is to transform a set of points (the target object) using another set of points (the structuring element). The most widespread practical examples of this type of process are the morphological image filters based on the basic morphological operators of erosion and dilation. Another example is the process of designing and manufacturing shapes in CAD/CAM environments as discussed before.

References about mathematical morphology are abundant in various productive sectors. A good review of these applications can be found in (ISSM, 2011), where the following fields appear: navigation systems, industrial control, medicine and biology, physics, aeronautics, geoscience and remote sensing, real-time systems and restoration processes. Image processing is one of the main uses of mathematical

morphology. In the work of Soille and Pesaresi (2002), Ghosh and Deguchi (2008), Salembier et al. (2009) and Velasco-Forero and Angulo (2011), recent techniques that apply mathematical morphology to image processing in several fields are detailed. However, few references about the relation between the morphological operations and industrial processes can be found. A model that closely relates the process of design and manufacture is the trajectory-based design model, which bases object design on defining trajectories that are covered by modeling tools that simulate the material removed from the piece (Molina, 2002), although the model does not address the problem from a morphological point of view. One of the first examples of morphological processing in industry is topological modeling of the manufacturing process, which linked industrial machining with the concept of morphological erosion (Jimeno et al., 2004).

Delving into the link between the process of material removal and the morphological operation of erosion, we can identify the tool with the structuring element and the manufactured piece with the object to be eroded. However, the non-deterministic nature of classic mathematical morphology makes it impossible to adapt their basic operations to the dynamics of concepts such as the ordered trajectory. The morphological operation is not based on temporary orders because their original ones act on continuous sets of points and produce new continuous sets of points as a result without establishing a path order on its elements. This order relationship is necessary when the morphological paradigm must deal with dynamic processes such as the trajectory process. In addition, the morphological operation always obtains complete results without being able to apply partial transformations to objects that are involved in the operation.

The process of machining is, in essence, a process based on the surfaces of the shapes because the surface of the tool touches the surface of the piece. This fact leads us to propose to only compute the boundaries of the shapes so the calculations will be simpler and faster. Our aim is to demonstrate that a boundary-based computation is as valid as the traditional morphological methods. Some other authors have proposed algorithms that implement boundary-based morphological operations. Ragnemalm (1992) and Meijster et al. (2000) present techniques that apply morphological operations based on analytical calculations of distance between the boundary points of objects. Van Vliet and Verwer present algorithms for the calculation of erosion, dilation, skeletonization and propagation of images based on the boundary of shapes (Van Vliet and Verwer, 1988), and Wilkinson and Meijer (1995) demonstrate a technique to classify images of microbiological organisms through the application of morphological operations to the boundary pixels of the images. However, the application of these techniques to the field of design and manufacturing is still unexplored.

To explore new possibilities of mathematical morphology in industrial environments, we present a formal framework inspired by the classic morphological paradigm that formally defines objects from their boundary and applies morphological operations that transform these objects. The model provides a specialization of the classic morphological operations, giving them the determinism of dynamic processes that require an order of application. The proposal is inspired by the needs of the field of design and manufacturing in CAD/CAM environments, but the results may be applied to other fields.

In section 2, the formal model of deterministic boundary-based mathematical morphology is presented, along with the definition of the objects, the structuring elements and the set of morphological operations. The generic trajectory-based operation is also detailed, as it is the basis of the specialization that gives determinism to the morphological operations. At the end of this section, the operators of trajectory-based erosion and dilation are defined, as are some morphological filters and some interesting results that support the validity of the boundary-based morphological operators. Finally, in section 3, some conclusions and findings are presented.

2 Deterministic boundary-based morphological model

The deterministic morphological framework DMM can be defined as a tuple:

$$\text{DMM} = \langle E, OB, SE, OP \rangle$$

Expression 2.1

where E represents the space of representation of the sets involved in the model, OB is the set of objects to be transformed by the morphological operations, SE represents the set of structuring elements through which the morphological operations are to be performed, and OP refers to the morphological operations for transforming the set of objects in OB using the structuring elements in SE .

Sets OB and SE are complete lattices that are made up of geometric points of the Euclidean space E . In the case of two-dimensional objects, E is \mathbf{R}^2 , and for three-dimensional objects, E is \mathbf{R}^3 . In general, E is \mathbf{R}^n . The proposed morphological operation is not restricted to a two-dimensional or three-dimensional space but is applicable to any space \mathbf{R}^n . To facilitate the representation, this article uses two-dimensional and three-dimensional figures, with these always being particular cases of the general set.

The set of structuring elements SE is determined by those objects that are centered on the origin of the Euclidean space coordinates, i.e.:

$$SE = \{B_x : x = \mathbf{0}, \mathbf{0} \in E\}$$

Expression 2.2

where the set $B_x \in SE$ is an object or shape moved to position x in the Euclidean space, hereinafter referred to as the *structuring element*. SE is a lattice with the classical inclusion as order in the lattice.

The set of objects to be transformed OB shall consist of those objects A whose center c has moved with regard to the origin of coordinates:

$$OB = \{A_c : c = \mathbf{0} + \mathbf{d}, \mathbf{d} \in E\}$$

Expression 2.3

where the set $A_c \in OB$ is also an object or shape moved to position c in the Euclidean space, hereinafter referred to as the *target object*. OB is also a lattice with the classical inclusion as order in the lattice.

Compared with the solid modeling presented by mathematical morphology, the proposed model is a surface model; i.e., it only works with the information in the

object surface without any information concerning its interior. Given these considerations, the relevant geometric information of the objects is located on its frontier or boundary. The model uses this to characterize the objects through its boundary but in such a way that this characterization does not result in a loss of generality.

Function $In(A)$ is defined to retrieve the set of points located inside a set $A \subset E$. The function obtains the set of positions in which the center of an n -solid ball can be placed so that it is positioned inside the object A :

$$\begin{aligned} In(A) &= \{x \in E / \exists \varepsilon > 0: Ball(x, \varepsilon) \subset A\} \\ Ball(x, \varepsilon) &= \{n - \text{ball with center } x \text{ and radius } \varepsilon\} \end{aligned}$$

Expression 2.4

The function that associates a set with its boundary or frontier is called $Fr(A)$ and shall consist of the set of points belonging to the frontier of the object A . This function is only the result of applying the boundary extraction morphological filter (β_0) (González and Woods, 2008), which is given by the remainder of object A (given that A is a closed set) with the set of interior points of the object:

$$Fr(A) = \beta_0 = A - In(A)$$

Expression 2.5

The differential morphology is given by the following expression:

$$\begin{aligned} A - B &= \{x | x \in A, x \notin B\} = A \cap B^c \\ B^c &= \{\text{complementary of } B\} \end{aligned}$$

Expression 2.6

Once the target objects and the structuring elements that will perform the transformations have been defined, the set of operations that will finally transform the set of objects OB from the set of objects SE must be formally defined.

In conventional mathematical morphology, the operations that transform objects are defined as a sequence of operations that act on the objects (Serra, 1982). No application order is set for these basic elementary operations.

Because the proposed model defines deterministic morphological processes, the morphological paradigm must incorporate a specialization of the morphological operations that adapts them to this type of processes. The determinism provided to the operation will ensure that the model complies with its functional purpose.

The morphological operations that transform the set of objects OB from the set of objects SE is defined by the following expression:

$$OP = \langle OP_{ND}, OP_D \rangle$$

Expression 2.7

where OP_{ND} represents the set of non-deterministic operations of classical nonlinear mathematical morphology, and OP_D represents the set of specialized morphological operations, equipped with an order of application.

Below, the generic trajectory-based operation is defined. The deterministic specialization of the basic morphological operations and their associated filters will be based on this simple operation.

2.1 Generic trajectory-based morphological operations

The *generic trajectory-based operation* ϕ_τ constitutes the basis of the proposed morphological specialization. This morphological operation allows the definition of the morphological operators that sequentially obtain ordered sets of points. This type of determinism does not exist in the classical morphological paradigm.

To guide the orderly generation of results, the operation obtains the set of points by repeatedly applying another fundamental operation, called *instantaneous trajectory-based operation* ($\phi_{\tau(k)}$). The sequential application of instantaneous trajectory-based operations will form the generic trajectory-based operation. In the following sections these operations are defined.

2.1.1 Trajectory function

As previously stated, the operations are performed on the boundary of the objects following an order to address the points. The function that allows orderly access to the frontier points is the so-called *trajectory function*.

As a previous step, let us define a real parameter function ζ . For a k value of a normalized space $[0,1]$, function ζ returns a pair of values (orientation, position), which define the transformations that must be performed on the target object to ensure that a particular boundary point of the object is accessible to the structuring element as it moves in the direction of the abscissa axis. Formally, this is expressed as follows:

$$\zeta : [0,1] \rightarrow \mathbf{R}^{(n+1) \times (n+1)} \times \mathbf{R}^{(n+1) \times (n+1)}$$

$$\zeta(k) = (\mathbf{POS}, \mathbf{ROT}) : \exists p \in A, \mathbf{POS} \cdot \mathbf{ROT} \cdot p \text{ can be accessed by } B$$

Expression 2.8

where **POS** and **ROT** are two transformation matrices in homogeneous coordinates that position and orientate the point p so that it can be touched by moving the structuring element B on the abscissa axis. The complete scan of the parametric space $[0,1]$ will describe the whole sequence of positions and orientations that must be applied to the target object so that the structuring element can come in contact with the total set of accessible points of the object boundary. This series of positions and orientations is ordered by a neighborhood criterion in the points so that the sequence of transformations is obtained in an orderly manner. Figure 1 illustrates a simple example, where the target object A is positioned and oriented to allow the structuring element B access to every point in the A frontier by just moving B on the abscissa axis.

FIGURE 1

Figure 1. Different points of contact of B with A after changing the position and orientation of A

At this point, it is important to emphasize that B is moved only along the abscissa axis for simplicity reasons, and no real restriction is added to the problem.

Function ζ allows the definition of the *trajectory function* τ . The point trajectory function $\tau(p, k)$ is defined for a point p and a parameter k as the function that applies the transformations of rotation and translation to ensure that a particular point p of the object will be accessible by the structuring element. The formal definition of the trajectory function τ of a point is as follows:

$$\tau : \mathbf{R}^n \times \mathbf{R} \rightarrow \mathbf{R}^n$$

$$\tau(p, k) = p' \in \mathbf{R}^n : p' = \mathbf{POS} \cdot \mathbf{ROT} \cdot p \wedge \zeta(k) = (\mathbf{POS}, \mathbf{ROT})$$

Expression 2.9

where **POS** and **ROT** are, respectively, the position and rotation matrices generated by the function ζ for the parametric value k . Notice that **POS** and **ROT** are transformation matrices in homogeneous coordinates, and they pre-multiply point p to obtain the transformed point p' .

Having specified the trajectory function for a point, defining a new function that extends the trajectory definition to the full set of points that form an object is trivial. The trajectory function for an object $\tau(A, k)$ will be given by applying the trajectory function for the entire set of points that constitute the object:

$$\tau : OB \times \mathbf{R} \rightarrow OB$$

$$\tau(A, k) = \{ p \in E / \forall q \in A, p = \tau(q, k) \}$$

Expression 2.10

The trajectory function in an object orients and positions the object so that a particular point of it is accessible by the structuring element as it moves in the direction of the abscissa axis. Because the transformations are only rotations and translations, the object will not suffer scaling transformations or deformations. As a result, the operation maintains the object shape even though its orientation and position are changed with respect to the structuring element in the representation space.

The sequential application of the trajectory function in the normalized parametrical space will transform the object in an orderly manner as the parameter takes consecutive values. The complete scan of the normalized space will ensure that all of the accessible points of the object boundary will come into contact with the structuring element as it moves in the direction indicated by the abscissa axis (provided that the geometry of the object and the structuring element allow this action).

2.1.2 Instantaneous trajectory-based operation

The proposed instantaneous trajectory-based operation ($\hat{\phi}_{\tau(k)}$) is a basic morphological operation that includes a k parameter that indicates its position within the total set of elementary operations that will compose the entire generic trajectory-based operation. The operation is called instantaneous because it obtains a single point of the total set of points that would be obtained following the application of a conventional morphological operation.

In descriptive terms, the instantaneous trajectory-based operation obtains the center of the structuring element when it is moved a distance *Dist* following a direction \mathbf{v}

until it touches a boundary object A to which the trajectory function has been applied. This operation represents the approach of the structuring element to the object in a morphological transformation process.

In particular, the instantaneous trajectory-based operation is formulated as follows:

$$A \diamond_{\tau(k)} B = p \in E, p = \tau^{-1}(q, k), q = \text{Dist}_{\mathbf{v}}(B, \tau(A, k)) \cdot \mathbf{v}$$

$$\tau^{-1} = \{\text{inverse of } \tau\}$$

Expression 2.11

Each of the instantaneous operations performs homogeneous transformations of the object. They are rigid body transformations defined in the trajectory function, which transformed the objects without scaling or distorting them. The inclusion of the trajectory function in the instantaneous operation ensures that the distance is always calculated between the structuring element and an accessible point of the boundary of the target object.

The function of distance $\text{Dist}_{\mathbf{v}}(B, A)$ describes the distance that one object B has to move to come into contact with another object A in a given direction \mathbf{v} . This distance is given by the minimum distance between the two objects in the direction determined by the given vector (Jimeno et al., 2004). In formal terms, this is expressed as follows:

$$\text{Dist}_{\mathbf{v}}(B, A) = \min(d_{\mathbf{v}}(b, A)), \forall b \in B$$

Expression 2.12

The function $d_{\mathbf{v}}$ describes the distance between a point and an object in the direction of vector \mathbf{v} . Geometrically, the function $d_{\mathbf{v}}(b, A)$ describes the Euclidean distance between the point b and the closest point of the object A , obtained as the intersection of the object A and the line defined by vector \mathbf{v} and point b . Figure 2 shows an example of the calculation of the $\text{Dist}_{\mathbf{v}}$ function.

FIGURE 2

Figure 2. Calculation of the distance function between two objects A and B in the direction of vector \mathbf{v}

The application of the trajectory function to an object modifies its position and orientation through the application of rotation and translation matrices. Applying the inverses of these matrices is enough to undo these changes.

The inverse trajectory function at a point τ^{-1} applies the inverse transformation matrices of rotation and position defined in the trajectory function to a point.

$$\tau^{-1} : \mathbf{R}^n \times \mathbf{R} \rightarrow \mathbf{R}^n$$

$$\tau^{-1}(q, k) = q' \in \mathbf{R}^n: q' = \mathbf{ROT}^{-1} \cdot \mathbf{POS}^{-1} \cdot q \wedge \zeta(k) = (\mathbf{POS}, \mathbf{ROT})$$

Expression 2.13

Figure 3 shows the application of the instantaneous trajectory-based operation on an object A as a series of four phases: a first phase (a) in which the structuring element B appears to be a distance from the object to be transformed A ; a second

phase (b) in which the trajectory function is applied to the object A for a determined k value; a third phase (c) in which the distance that the center of the structuring element has to move to come into contact with the object is calculated; and a final stage (d) in which the inverse trajectory function is applied to the tool used to calculate the end point p that the morphological operation obtains.

FIGURE 3

Figure 2. Geometric description of the instantaneous trajectory-based operation. A is the piece, B is the structuring element, p is a point in the surface, q is the center of the structuring element and v is the direction of application.

2.1.3 Generic trajectory-based operation

Having defined the instantaneous trajectory-based operation $\phi_{\tau(k)}$, which yields a specific point in the parametrical space in which the complete transformation of the object is defined, the repeated application of these instantaneous trajectory-based operations throughout the complete parametric space will define the generic operation with complete trajectory ($A \phi_{\tau} B$) by itself.

$$A \phi_{\tau} B = \bigcup_{k \in [0,1]} A \phi_{\tau(k)} B$$

Expression 2.14

Sequentially applying instantaneous operators in all of the parametric k range ensures that the morphological operator is fully implemented. The parametric k value is normalized, meaning that all of the transformations are ordered according to the parameter with an initial value $k=0$ and a final value $k=1$. In the generation of results, this order is associated with the ordered set that establishes the trajectory function. The generic trajectory-based operation links a sequence of morphological operations, establishing a determinism that will provide an orderly movement in the space, a determinism that does not exist in the classic morphological paradigm.

Furthermore, it is important to emphasize once more that the objects involved in the morphological translations and rotations applied in the generic trajectory-based operation do not vary in size and shape; only their position and orientation in space are altered. The purpose of the instantaneous trajectory-based operation is not to change the shape of objects, but to sequence the results generated by the morphological transformation operations, which will be responsible for modifying the shape of the objects OB , reproducing the processes of the deterministic systems.

2.1.4 Generic partial trajectory-based operations

The trajectory function τ ensures that the instantaneous operator is completely applied to the entire set of points that form the accessible boundary of the object ordered according to the parametric space $k \in [0,1]$. However, trajectories can be defined that do not go through the entire parametric space, forming subsets of the complete morphological operation. The partial path of parametric space constitutes the *partial trajectory-based operation* ($A \phi_{\tau < i, j >} B$):

$$A \diamond_{\tau \langle i, j \rangle} B = \bigcup_{k \in [i, j]} A \diamond_{\tau(k)} B, 0 \leq i < j \leq 1$$

Expression 2.15

2.2 Trajectory-based morphological operations: erosion and dilation

Having defined the generic, partial or complete trajectory-based operation, the next step is to integrate this operation into the classic morphological operation, thus incorporating a set of morphological operations (OP_D) into the model, which are provided with the determinism and which transform an object using a structuring element.

There are two fundamental morphological operations in classic mathematical morphology: erosion and dilation. Both operations are the basis for the definition of morphological filtering operators. They are formally defined below, and the specialization that the model performs to provide them with determinism is specified.

2.2.1 Trajectory-based erosion

In mathematical morphology, the erosion operation can be defined by the following expression:

$$A \ominus B = \{y \in E, B_y \subseteq A\}$$

Expression 2.16

A descriptive interpretation of the operation defines it as the place of the positions of the center of the structuring element B when it is included in A . The erosion boundary is defined by the centers of the structuring element when it touches the inner edge of the target object.

The morphological erosion acts on the set of points of A , consequently producing a new set of points that is transformed without establishing a trajectory order on its elements. This ordered set is needed when the morphological paradigm has to perform deterministic dynamic processes.

The model incorporates a specialization of the morphological erosion operation based on the use of the instantaneous trajectory-based operation to provide the morphological erosion with that necessary determinism.

The *instantaneous trajectory-based erosion* $\ominus_{\tau(k)}$ is defined by integrating the instantaneous trajectory-based operation into the erosion operation. The final complete erosion set is obtained by repeatedly applying the instantaneous erosion, as a step in the morphological erosion. Formally, this is expressed as follows:

$$A \ominus_{\tau(k)} B = p \in E : p = \tau^{-1}(q, k), q = \text{Dist}_v(B, \tau(A, k)) \cdot \mathbf{v} \wedge B_q \subseteq \tau(A, k)$$

Expression 2.17

At this point, an explanation about the distance function Dist_v , which calculates the minimum distance between the object and the structuring element, is needed. To perform the morphological trajectory-based erosion, the morphological erosion definition requires the structuring element B to be completely included in the object A . The distance function integrated into the morphological erosion calculates the minimum distance from the object A to the element B , thus fulfilling the restriction of

placing the structuring element within the object. This situation does not occur for morphological operators such as dilation in which the structuring element must touch the object from the outside of it.

Trajectory-based erosion \ominus_τ is defined as the set of points obtained by repeatedly applying the instantaneous erosion $\ominus_{\tau(k)}$ for the real domain $[0,1]$.

$$A \ominus_\tau B = \bigcup_{k \in [0,1]} (A \ominus_{\tau(k)} B) = \{p \in E : p = \tau^{-1}(q, k), q = \text{Dist}_v(B, \tau(A, k)) \cdot v \wedge B_q \subseteq \tau(A, k)\}$$

Expression 2.18

The trajectory function τ ensures a path inside object A in the normalized space $[0,1]$. If the real variable k takes its values from the interval, the erosion boundary of the complete object is obtained as a result, as it will have obtained all of the centers of the structuring element when it touches the object.

At this point, the difference between classic morphological erosion and trajectory-based erosion can be observed. Whereas the result for classic morphological erosion was a set of continuous points representing the frontier of the eroded object and its inside, the trajectory-based erosion only provides the frontier of the eroded object in an orderly manner with surface information of the objects obtained in the absence of any information about its interior (Figure 4).

FIGURE 4

Figure 3. Classic morphological erosion vs. morphological trajectory-based erosion

Although the two operations do not return the same set of points, the morphological erosion boundary and trajectory-based erosion do coincide: If A and B are two sets included in E , then the trajectory-based erosion is a subset of the erosion, and, more precisely, it is equal to the erosion's boundary. These facts can be proven by the formal proof method of *reduction ad absurdum*.

Proposition 1. The trajectory-based erosion is a subset of the classical erosion. Formally, this is expressed as follows:

$$A \ominus_\tau B \subseteq A \ominus B$$

Expression 2.19

Proof. Suppose there exists $p \in A \ominus_\tau B$ such that $p \notin A \ominus B$.

- (i) Because of the definition of erosion (expression 2.16), if $p \notin A \ominus B$, then $B_p \not\subseteq A$.
- (ii) Because of the definition of trajectory-based erosion (expression 2.18), if $p \in A \ominus_\tau B$, then $p \in \bigcup_{k \in [0,1]} (A \ominus_{\tau(k)} B)$, and so $\exists k \in [0,1] : p \in (A \ominus_{\tau(k)} B)$. From the definition of $(A \ominus_{\tau(k)} B)$ (expression 2.17), the following result is obtained: $B_p \subseteq A$, which is a contradiction with the result in (i).

Therefore, the trajectory-based erosion is a subset of the classical erosion ■.

Theorem 1. If A and B are two sets included in E , then the trajectory-based erosion is equal to the boundary of the classical morphological erosion.

$$A \ominus_{\tau} B = Fr(A \ominus B)$$

Expression 2.20

Proof. Let us prove the equality, proving the inclusion in both directions.

- (i) $A \ominus_{\tau} B \subseteq Fr(A \ominus B)$. Let p be a point of the trajectory-based erosion ($p \in A \ominus_{\tau} B$). From the definition of $A \ominus_{\tau} B$ (expression 2.18), $p \in \bigcup_{k \in [0,1]} (A \ominus_{\tau(k)} B)$, and so $\exists k \in [0,1]: p \in (A \ominus_{\tau(k)} B)$. From the definition of trajectory-based erosion (expression 2.17), $p = \tau^{-1}(q, k)$, $q = Dist_{\mathbf{v}}(B, \tau(A, k)) \cdot \mathbf{v} \wedge B_q \subseteq \tau(A, k)$, that is, the distance in the direction of \mathbf{v} between p , which is the center of the structuring element, and the boundary of the target object once transformed is a given quantity, say d (see Figure 5). Let us suppose now that $p \notin Fr(A \ominus B)$. Because of the definition of $Fr(A \ominus B)$ (expression 2.5), if $p \notin Fr(A \ominus B)$, then $p \notin [(A \ominus B) - In(A \ominus B)]$, and because of proposition 1 (expression 2.19) and given hypothesis $p \in A \ominus_{\tau} B$, it can be determined that $p \in In(A \ominus B)$. By the definition of function $In(A \ominus B)$ (expression 2.4), if $p \in In(A \ominus B)$, then $\exists \varepsilon > 0: Ball(p, \varepsilon) \subset (A \ominus B)$. In other words, because p is in the inner part of $(A \ominus B)$, there exists a ball of radius $\varepsilon > 0$ around p such that all the points in the ball are inside the set $(A \ominus B)$. Because of the definition of $Ball$ (expression 2.4), it can be determined that $\forall q \in Fr(A \ominus B)$, the distance between p and q (a point in the boundary of $(A \ominus B)$), is $> \varepsilon$ (see Figure 6). The distance between q and the boundary of the target object A in the direction of \mathbf{v} is d , so the distance between p and the boundary of A is $\geq d + \varepsilon$, which is a contradiction.

FIGURE 5

Figure 5. Morphological erosion with a rectangular structuring element and a detail concerning calculating the morphological trajectory-based erosion

FIGURE 6

Figure 6. Detail of the boundary of the morphological erosion: $p \in In(A \ominus B)$ and $q \in Fr(A \ominus B)$.

- (ii) $Fr(A \ominus B) \subseteq A \ominus_{\tau} B$. Let p be a point on the frontier of the classical erosion ($p \in Fr(A \ominus B)$). From the definition of $Fr(A \ominus B)$ (expression 2.5), then $p \in [(A \ominus B) - In(A \ominus B)]$, and so $p \notin In(A \ominus B)$. By the definition of function $In(A \ominus B)$ (expression 2.4), if $p \notin In(A \ominus B)$, then $\nexists \varepsilon > 0: Ball(p, \varepsilon) \subset (A \ominus B)$. In other words, there is not a ball of radius $\varepsilon > 0$ around p such that all the points in the ball are inside the set $(A \ominus B)$. Let us suppose now that $p \notin A \ominus_{\tau} B$. From the definition of $A \ominus_{\tau} B$ (expression 2.18), $p \notin \bigcup_{k \in [0,1]} (A \ominus_{\tau(k)} B)$, and so $\nexists k \in [0,1]: p \in (A \ominus_{\tau(k)} B)$, $p = \tau^{-1}(q, k)$, $q = Dist_{\mathbf{v}}(B, \tau(A, k)) \cdot \mathbf{v} \wedge B_q \subseteq \tau(A, k)$, that is, if the distance in the direction of \mathbf{v} between any point $q \in A \ominus_{\tau} B$, and the boundary of the target object, once transformed, is a given quantity d , point p is not at a distance d , but at a distance $d + \varepsilon$. Given $p \in Fr(A \ominus B)$, $p \in (A \ominus B)$ too, and so $\varepsilon > 0$. As a consequence, a ball of radius >0 around p can be defined, so $\exists \varepsilon > 0: Ball(p, \varepsilon) \subset (A \ominus B)$, which is a contradiction. Given that $A \ominus_{\tau} B \subseteq Fr(A \ominus B)$ and $A \ominus_{\tau} B \subseteq Fr(A \ominus B)$ are proven, the initial expression $A \ominus_{\tau} B = Fr(A \ominus B)$ is proven ■.

2.2.2 Partial trajectory-based erosion

Trajectory-based erosion can control the order in which the points are obtained in the final set. Having defined the partial ordered set \leq in E , an orderly series of parametric k values on the interval $[0,1]$ will therefore cause the centers of the structuring element centers to be obtained in an orderly manner, according to the movement defined by the trajectory function τ .

Although the trajectory-based erosion can define the complete erosion boundary, if the transformation does not cover the entire parametric space k , the result of applying the trajectory-based erosion is a partial erosion of the object.

$$A \ominus_{\tau \leq i, j} B = \bigcup_{k \in [i \dots j]} A \ominus_{\tau(k)} B, 0 \leq i < j \leq 1$$

Expression 2.21

2.2.3 Trajectory-based dilation

In mathematical morphology, dilation is defined by the following expression:

$$A \oplus B = \{x \in E, B_x \cap A \neq \emptyset\}$$

Expression 2.22

In descriptive terms, this operation can be defined as the place of the center positions of the structuring element B when it touches the set A . For example, for $E \equiv \mathbf{R}^2$, the dilation of a square by a circular object is a larger square with rounded corners.

We define the instant dilation $\oplus_{\tau(k)}$ as a morphological dilation step:

$$A \oplus_{\tau(k)} B = p \in E: p = \tau^{-1}(q, k), q = \text{Dist}_v(B, \tau(A, k)) \cdot \mathbf{v} \wedge B_q \cap \tau(A, k) \neq \emptyset$$

Expression 2.23

For instantaneous dilation, the distance function Dist_v will calculate the minimum distance from object A to object B with the condition that the structuring element is outside the object.

Trajectory-based dilation is given by the set of points obtained by repeatedly applying the instantaneous dilation $\oplus_{\tau(k)}$ to the real domain $[0,1]$.

$$A \oplus_{\tau} B = \bigcup_{k \in [0,1]} (A \oplus_{\tau(k)} B) =$$

$$= \{p \in E: p = \tau^{-1}(q, k), q = \text{Dist}_v(B, \tau(A, k)) \cdot \mathbf{v} \wedge B_q \cap \tau(A, k) \neq \emptyset\}$$

Expression 2.24

The result of the trajectory-based dilation is an ordered set of points dilated with regard to the original object, which will coincide with the boundary of the classic morphological dilation.

As occurred with erosion, the boundary of the classic dilation can be proven to coincide with the trajectory-based dilation.

Theorem 2. If A and B are two sets included in E , then the trajectory-based dilation is equal to the boundary of the classical morphological dilation.

$$A \oplus_{\tau} B = Fr(A \oplus B)$$

Expression 2.25

The proof of this theorem is very similar to the proof for theorem 1. It is not included here for text simplification reasons.

2.2.4 Partial trajectory-based dilation

Again, if the trajectory does not completely cover the parametric space k , the result of applying the trajectory-based dilation is a partial dilation of the object.

$$A \oplus_{\tau \langle i,j \rangle} B = \bigcup_{k \in [i..j]} A \oplus_{\tau(k)} B, 0 \leq i < j \leq 1$$

Expression 2.26

2.2.5 Trajectory-based erosion and dilation, a pair of morphological operators

The Adjunction Theorem details the conditions under which a pair of operations is an erosion/dilation pair (Heijmans and Ronse, 1990). This theorem is based on the Galois connections that establish particular correspondences between partially ordered sets. It suffices to apply the Adjunction Theorem to formally prove that the erosion and dilation operations presented are effectively such.

The adjunction theorem states that if two operators δ and ε are linked by the equivalence $X \subseteq \varepsilon(Y) \leftrightarrow \delta(X) \subseteq Y$, then necessarily ε and δ form an erosion/dilation

pair. To extend this result to the trajectory-based erosion and dilation pair, a new relation, the *inside* relation, must be defined: A set X is inside a boundary set Y (denoted $X \subseteq_o Y$) if and only if X is inside the interior region defined by Y . In formal terms, this is expressed as follows:

$$Y = Fr(A); X \subseteq_o Y \leftrightarrow X \subseteq A$$

Expression 2.27

Now, the Adjunction Theorem can be adapted to trajectory-based operands.

Theorem 3. The trajectory-based erosion (\ominus_τ) and the trajectory-based dilation (\oplus_τ) form an erosion/dilation pair that is expressed as follows:

$$X \subseteq_o (Y \ominus_\tau B) \leftrightarrow (X \oplus_\tau B) \subseteq_o Y, \forall B \in SE$$

Expression 2.28

Proof. Let us prove the equivalence proving the implication in both directions.

(i) $X \subseteq_o (Y \ominus_\tau B) \rightarrow (X \oplus_\tau B) \subseteq_o Y$. In descriptive terms, if a set X of points is inside the region defined by the result of the trajectory-based erosion of an object Y , then the trajectory-based dilation of the set of points X will necessarily be inside the region defined by Y . In the following paragraphs, the trajectory-based erosion and dilation will be simply referred to as erosion and dilation to improve the readability of the proof.

Let Y be a set of points and X' the set of points that is the result of eroding the object Y by any structuring element B :

$$\begin{aligned} X' &= Y \ominus_\tau B = \bigcup_{k \in [0,1]} (Y \ominus_{\tau(k)} B) \\ &= \{p \in E : p = \tau^{-1}(q, k), q = Dist_{\mathbf{v}}(B, \tau(Y, k)) \cdot \mathbf{v} \wedge B_q \subseteq \tau(Y, k)\} \end{aligned}$$

Expression 2.29

If p is any point of the set X' , p is the minimal translation that the structuring element has to perform following the direction vector \mathbf{v} for it to be placed on the inside of the object Y touching at least one point c of the object. The point of contact c will depend on the parametric value k used in the instantaneous trajectory-based operation.

Let us now define Y' as the set of points that is the result of dilating the object X' by the same structuring element B :

$$\begin{aligned} Y' &= X' \oplus_\tau B = \bigcup_{k \in [0,1]} (X' \oplus_{\tau(k)} B) = \\ &= \{p \in E : p = \tau^{-1}(q, k), q = Dist_{\mathbf{w}}(B, \tau(X', k)) \cdot \mathbf{w} \wedge B_q \cap \tau(X', k) \neq \emptyset\} \end{aligned}$$

Expression 2.30

If q is any point of the set Y' , q is the minimum translation that the structuring element has to perform following the direction vector \mathbf{w} for it to

be placed on the outside of the object X' touching at least one point d of the object.

If the direction vectors \mathbf{v} and \mathbf{w} have opposite directions, the point p of the erosion will necessarily coincide with the contact point d of the dilation, and contact point c of the erosion will coincide with the computed point q of the dilation (Figure 7). Therefore, any point of Y' will be inside the set Y , that is $Y' \subseteq_{\circ} Y$. If X is any set that is inside X' , its dilation will be inside Y' (which is the dilation of X'), and the dilation of X will be inside Y . More formally, this is expressed as follows:

$$X \subseteq_{\circ} X' \wedge Y' \subseteq_{\circ} Y \rightarrow X \oplus_{\tau} B \subseteq_{\circ} Y' \wedge X \oplus_{\tau} B \subseteq_{\circ} Y$$

Expression 2.31

FIGURE 7

Figure 7. Proof of the Adjunction Theorem in trajectory-based operators

As a consequence, $X \subseteq_{\circ} (Y \ominus_{\tau} B) \rightarrow (X \oplus_{\tau} B) \subseteq_{\circ} Y$ is proven.

- (ii) $(X \oplus_{\tau} B) \subseteq_{\circ} Y \rightarrow X \subseteq_{\circ} (Y \ominus_{\tau} B)$: The proof is analogous. From a given set of points X , its dilation is obtained (Y'). Then, the erosion is applied to Y' to obtain the set X' . If the direction vectors used for the dilation and the erosion are opposite, the point calculated for the dilation will necessarily coincide with the point of contact of the erosion with the object, and the point of contact of the dilation with the object will coincide with the point calculated by the erosion. Therefore, any point of X will be inside the set X' , that is $X \subseteq_{\circ} X'$. If Y is any set so that Y' is inside it, X' (which is the erosion of Y') will be inside the erosion of Y , and X will be inside the erosion of Y . Therefore, $(X \oplus_{\tau} B) \subseteq_{\circ} Y \rightarrow X \subseteq_{\circ} (Y \ominus_{\tau} B)$ is proven.

The general expression is proven by proving the two implications, which states that the trajectory-based erosion and dilation operations are effectively a morphological dilation and erosion pair ■.

2.3 Basic morphological trajectory-based filters: opening and closing

Morphological erosion and dilation form the basic composition of the so-called morphological filters that are obtained by combining the two basic operations. The following defines the specialization of the two most used filters, although the entire extension of the morphological operation is covered by the definition of trajectory-based erosion and dilation.

Let us present some previous results that will help to understand the definition of the operation.

Proposition 2. The interior of a set obtained as the result of the trajectory-based operation is empty. More formally, this is expressed by the following:

$$In(A \diamond_{\tau} B) = \emptyset$$

Expression 2.32

Proof. Suppose $\exists p \in In(A \diamond_{\tau} B)$. By definition of In (expression 2.4), $\exists \varepsilon > 0$: $Ball(p, \varepsilon) \subset A \diamond_{\tau} B$; that is, a ball of radius >0 can be traced around p such that every point in the ball is inside the set $A \diamond_{\tau} B$. From the definition of trajectory-based morphological operation (expressions 2.11 to 2.14), the distance between p and the target object A is the minimum possible distance such that the structuring element B is touching the boundary of A . Let q be one the points in the ball around p , such that q is placed in the direction of vector \mathbf{v} used to calculate the operation. The distance from q to A would be shorter than the distance from p to A , so q would be in $A \diamond_{\tau} B$ instead of p , which is a contradiction. Therefore, $In(A \diamond_{\tau} B)$ is empty ■.

Lemma 1.

$$Fr(A \diamond_{\tau} B) = A \diamond_{\tau} B$$

Expression 2.33

Proof. By definition of Fr (expression 2.5), $Fr(A \diamond_{\tau} B) = (A \diamond_{\tau} B) - In(A \diamond_{\tau} B)$. As per proposition 2, $In(A \diamond_{\tau} B) = \emptyset$, it is trivial that $Fr(A \diamond_{\tau} B) = A \diamond_{\tau} B$ ■.

Lemma 1 allows the definition of composed trajectory-based morphological operations because Fr is an idempotent operation in this case.

2.3.1 Trajectory-based opening

The classic morphological opening of A by B is obtained by eroding A by B and then dilating the resulting object by B . Formally, this is expressed as follows:

$$A \circ B = (A \ominus B) \oplus B$$

Expression 2.34

In descriptive terms, the opening is the geometric locus of structuring element B translations within the object A :

$$A \circ B = \bigcup_{B_x \subset A} B_x$$

Expression 2.35

In the opening, there are two trajectory-based operations, an erosion and a dilation, that generate different trajectories. The erosion places the structuring element on the inside of the object, touching its boundary, while the dilation places it on the outside, also touching its boundary (in this case the boundary of the erosion). Morphological trajectory-based opening thus includes the definition of two functions of trajectory, τ_1 and τ_2 , that will cover two sets of position-rotation values by describing the erosion and dilation trajectories that form the instantaneous morphological opening operation.

Trajectory-based opening will be achieved by applying the trajectory-based erosion operator, followed by a trajectory-based dilation (Figure 8):

$$A \circ_{\tau} B = (A \ominus_{\tau_1} B) \oplus_{\tau_2} B$$

Expression 2.36

FIGURE 8

Figure 8. Trajectory-based opening of a rectangular shape with a circular object

2.3.2 Trajectory-based closing

The closure of A by B is obtained by the dilation of A by B , followed by the erosion of the resulting object by B . Formally, this is expressed as follows:

$$A \bullet B = (A \oplus B) \ominus B$$

Expression 2.37

The geometrical interpretation of closure is similar to that of the opening operator. The difference is that the movement of the structuring element is produced outside the object boundary, causing the contours to become smooth and the concavities or small holes to close. As happens with the opening, morphological trajectory-based closing includes the definition of two functions of trajectory τ_1 and τ_2 , which define the dilation and erosion trajectories that form the closing operation.

The closing operator is defined as the application of a trajectory-based dilation followed by a trajectory-based erosion:

$$A \bullet_{\tau} B = (A \oplus_{\tau_1} B) \ominus_{\tau_2} B$$

Expression 2.38

Figure 9 shows the result of applying the complete trajectory-based closure of an object with concavities, as performed using a circular structuring element:

FIGURE 9

Figure 9. Trajectory-based closing of a concave polygon with a circular object

3 Conclusion

A morphological model has been presented that allows dynamic processes to be modeled using the formal framework provided by mathematical morphology. A specialization of classic morphological operations has been defined, providing it with the determinism inherent in dynamic processes such as designing and manufacturing objects by machining. The specialization is based on a trajectory function, which uses

translation and rotation transformations of the target objects to facilitate the complete and orderly implementation of morphological operations.

The point-based computations and the use of simple transformations, make the model simple and generic. As a result, it has proven to be suitable for any structuring element and piece shape, including convex, non-convex and non-star polygons (Figure 10).

FIGURE 10

Figure 10. Erosion of non-convex and non-star pieces, using two different structuring elements

The model has been defined to support the needs of CAD/CAM processes. Its validity was demonstrated by Sarabia et al. (2010), who presents a computer system for designing three-dimensional objects by trajectory, based on the morphological model presented (Figure 11). The computer system develops an environment of pieces modeled by trajectory using the deterministic morphological framework, providing solutions for designing complex objects and arithmetical support to generate machining trajectories, one of the most complex problems currently occurring in computer-aided design and manufacturing environments. In this context, the results have proven to be accurate and efficient.

FIGURE 11

Figure 11. Example of solid modeling from deterministic morphology

Although the morphological framework is applied in object design and manufacturing environments, its utility is not restricted to such processes. A clear example of an application beyond the object manufacturing process is image analysis. As mentioned in the introduction, since its very inception, mathematical morphology has been used in the analysis and filtering of images; this is not surprising, as morphological filters are often used in numerous scientific disciplines. The model presented can contribute to these fields by regularizing morphological operations that provide partial filtering and image ordering as results.

4 References

- ISSM, 2011. International Symposium on Mathematical Morphology, 2011. Vancouver, BC, Canada.
- Ghosh P.K., Deguchi, K., 2008. Mathematics of shape description: A morphological approach to image processing and computer graphics, Wiley Editions.
- González R., Woods, R., 2008. Digital Image Processing. Prentice Hall.
- Heijmans H.J.A.M., Ronse, C., 1990. The algebraic basis of mathematical morphology I. Dilations and erosions. *Computer Vision, Graphics, and Image Processing*, Vol. 50, Issue 3, 245-295, 0734-189X.
- Jimeno, A.M., Maciá, F., García-Chamizo, J., 2004. Trajectory-based morphological operators: a morphological model for tool path computation. In: Proceedings of the

international conference on algorithmic mathematics & computer science, AMCS Las Vegas.

- Meijster, A., Roerdink, J.B.T.M., Hesselink, W.H., 2000. A general algorithm for computing distance transforms in linear time. *Mathematical Morphology and its Applications to Image and Signal Processing*, Kluwer Acad. Publ., Dordrecht, 331-340.
- Molina, R., 2002. Modelo Superficie – Trayectoria. Un modelo geométrico para el diseño y la fabricación de objetos tridimensionales. Dissertation. Universidad de Alicante.
- Ragnemalm, I., 1992. Fast erosion and dilation by contour processing and thresholding of distance maps, *Pattern Recognition Letters* 13, 161-166.
- Salembier, P., Wilkinson, M., Clairon, S., Jean, P., 2009. Connected operators. A review of region-based morphological image processing techniques, *IEEE Signal Processing Magazine* 26, 136-157.
- Sarabia, R., Jimeno, A., Molina, R., 2010. A Morphological Approach to the Design of Complex Objects. *Journal of Manufacturing Science and Engineering* 132, 051003-7.
- Serra, J., 1982. *Image Analysis and Mathematical Morphology*. Academic Press, London.
- Serra, J., 1988. *Image Analysis and Mathematical Morphology. Volume 2: Theoretical Advances*. Academic Press, London.
- Soille P., Pesaresi M., 2002. Advances in Mathematical Morphology Applied to Geoscience and Remote Sensing. *IEEE Transactions on Geoscience and Remote Sensing* Vol. 40, No. 9, 2042-2055.
- Van Vliet, L., Verwer, B., 1988. A contour processing method for fast binary neighbourhood operations, *Pattern Recognition Letters* 727-36.
- Velasco-Forero S., Angulo J., 2011. Supervised Ordering in \mathbb{R}^p : Application to Morphological Processing of Hyperspectral Images. *IEEE Transactions on Image Processing*, Vol. 20, No. 11, 3301-3308.
- Wilkinson M., Meijer, B., 1995. DATAPLOT: A graphical display package for bacterial morphometry and fluorimetry data, *Computer Methods and Programs in Biomedicine* 47, 35-49.

Figure 1

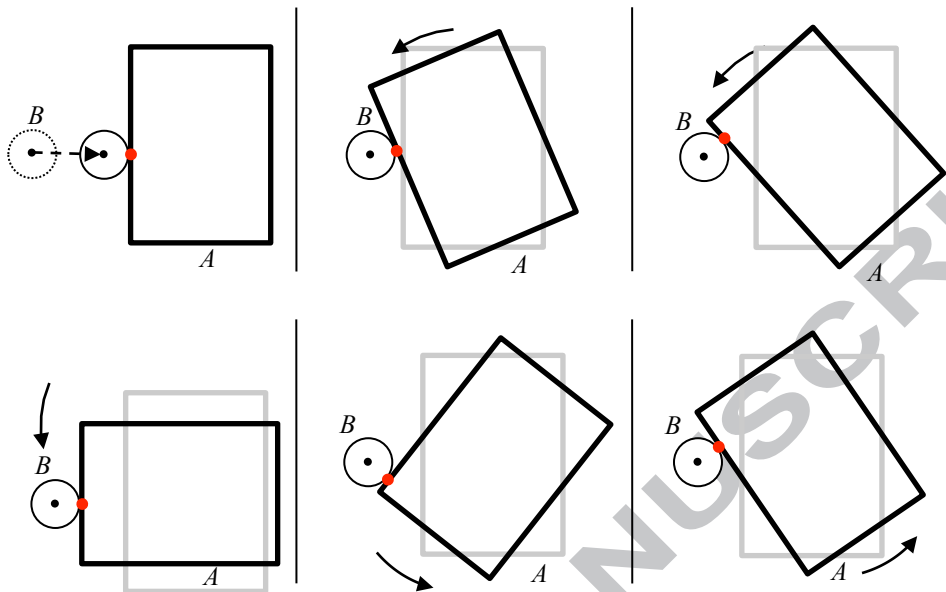

Figure 2

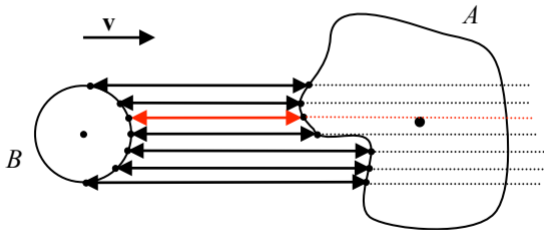
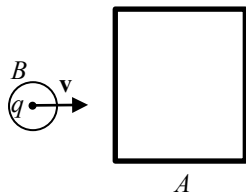
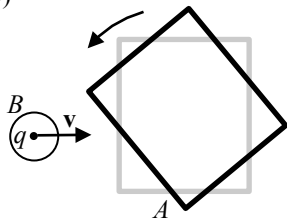

Figure 3

(a)



(b)



(c)

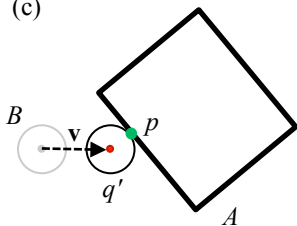

(d)

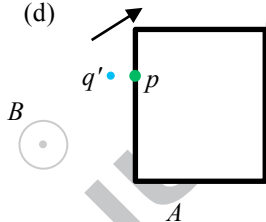
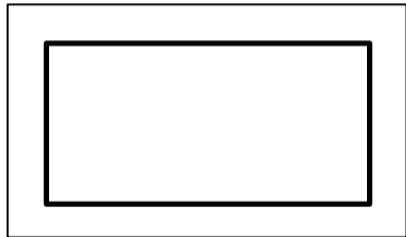

Figure 4



Classic morphological erosion



Trajectory-based morphological erosion

CRUI

Figure 5

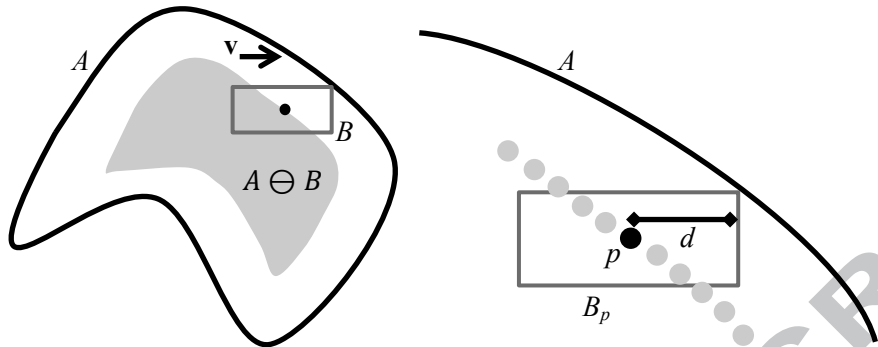

Figure 6

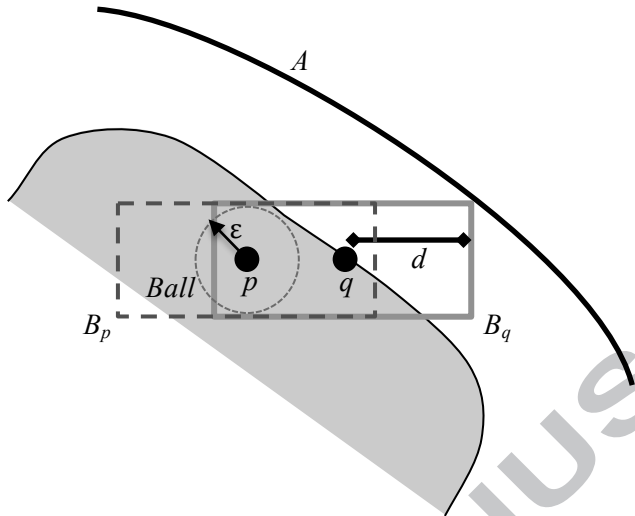

Figure 7

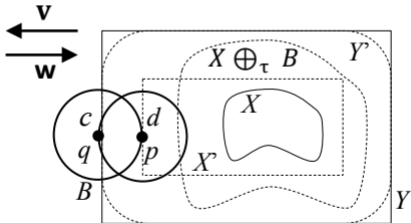

Figure 8



Figure 9

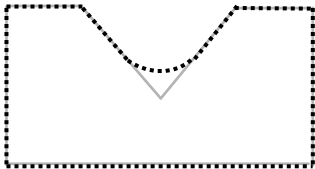

Figure 10.

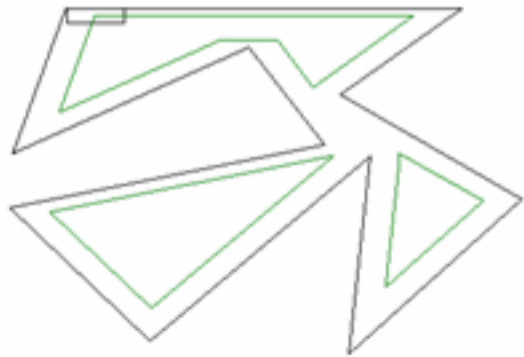
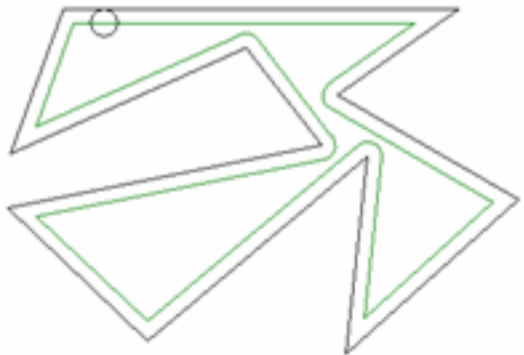
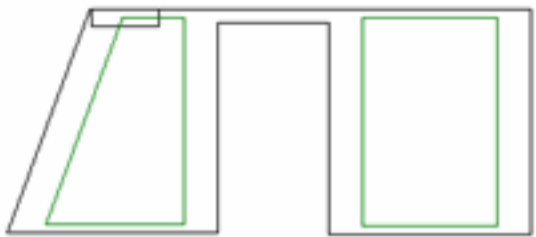
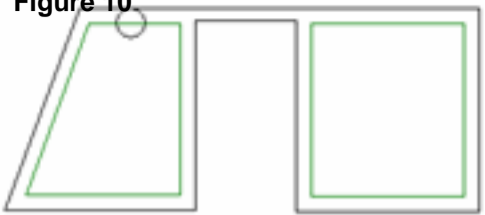

Figure 10

