

UNIVERSITY OF LONDON

THE DEVELOPMENT OF EXCIMER LASER CORNEAL SURGERY

A thesis submitted for the degree of Doctor of Medicine

David S Gartry

MB,BS,FRCS(England),FRCOphth,BSc(Hons),DO(RCS),FBCO

Formerly: Iris Fund Excimer Laser Research Fellow

The United Medical and Dental Schools of Guy's and St Thomas' Hospitals
and

The Institute of Ophthalmology, London

Currently: Corneal Fellow
Moorfields Eye Hospital
City Road, London

June 1995

ProQuest Number: 10042908

All rights reserved

INFORMATION TO ALL USERS

The quality of this reproduction is dependent upon the quality of the copy submitted.

In the unlikely event that the author did not send a complete manuscript and there are missing pages, these will be noted. Also, if material had to be removed, a note will indicate the deletion.



ProQuest 10042908

Published by ProQuest LLC(2016). Copyright of the Dissertation is held by the Author.

All rights reserved.

This work is protected against unauthorized copying under Title 17, United States Code.
Microform Edition © ProQuest LLC.

ProQuest LLC
789 East Eisenhower Parkway
P.O. Box 1346
Ann Arbor, MI 48106-1346

TABLE OF CONTENTS

Title Page.....	1
Table of contents.....	3
List of figures.....	11
List of tables.....	17
Abstract of thesis.....	21
Acknowledgements.....	23

SECTION I

INTRODUCTION.....	25
--------------------------	-----------

CHAPTER 1:

CONVENTIONAL CORNEAL SURGERY.....	27
1.1 The structure and function of the normal cornea.....	29
1.2 Essential prerequisites of corneal surgery.....	31
1.3 Indications for corneal surgery.....	32
1.4 Current corneal surgical procedures and their limitations.....	32
1.4.1 Epithelial debridement and anterior stromal puncture.....	32
1.4.2 Superficial keratectomy for band keratopathy.....	32
1.4.3 Lamellar keratoplasty.....	33
1.4.4 Penetrating keratoplasty.....	33
1.5 Refractive corneal surgery.....	34
1.5.1 Introduction.....	34
1.5.2 Radial keratotomy.....	34
1.5.3 Arcuate keratotomy.....	36
1.5.4 Keratomileusis.....	37

1.5.5 Keratophakia.....	37
1.5.6 Epikeratophakia.....	37
1.6 General comments.....	38

CHAPTER 2:

LASERS IN CORNEAL SURGERY.....	39
2.1 The potential of lasers in corneal surgery.....	41
2.2 The basic principles of lasers.....	41
2.2.1 Monochromaticity.....	42
2.2.2 Directionality.....	42
2.2.3 Intensity/brightness.....	42
2.2.4 Coherence.....	42
2.2.5 Mode structure.....	42
2.3 The production and emission of laser light.....	43
2.3.1 The active lasing medium.....	43
2.3.2 The energy source.....	43
2.3.3 The optical resonator.....	43
2.4 Interaction of laser light with the cornea.....	44
2.5 Historical overview of laser corneal surgery.....	46

CHAPTER 3:

THE DEVELOPMENT OF EXCIMER LASER CORNEAL SURGERY.....	47
3.1 Background.....	49
3.2 The lasing medium and beam-tissue interactions.....	50
3.3 Hazards of excimer laser radiation and safety.....	57
3.3.1 Penetration of excimer laser radiation at 193nm.....	58
3.3.2 Mutagenesis.....	58

3.3.3	Secondary fluorescence and cataractogenesis.....	59
3.3.4	Acoustic shock waves.....	60
3.3.5	The generation of toxic free-radicals.....	60
3.4	The first clinical applications of the excimer laser.....	61
3.4.1	Treatment of corneal scars.....	61
3.4.2	Early 'incisional keratotomy'.....	62
3.5	Aims in the evaluation of excimer laser corneal surgery.....	63
3.5.1	Efficacy and safety of phototherapeutic keratectomy.....	63
3.5.2	Efficacy, safety and predictability of PRK.....	63
3.5.3	The role of topical corticosteroids following PRK.....	63

SECTION II

INSTRUMENTATION.....	65
-----------------------------	-----------

CHAPTER 4:

TECHNICAL DESCRIPTION OF THE LASER USED IN THIS STUDY.....	67	
4.1	Production and emission of excimer laser radiation.....	69
4.2	The beam delivery system.....	70
4.3	Photorefractive keratectomy algorithms.....	72

SECTION III

THE DEVELOPMENT OF PHOTOTHERAPEUTIC KERATECTOMY.....	79
---	-----------

CHAPTER 5:

LABORATORY MODELS OF CORNEAL SMOOTHING.....	81	
5.1	Introduction.....	83
5.1.1	Preliminary laboratory evaluation/aims of the study.....	83

5.2	Materials and Methods.....	84
5.2.1	Excimer laser pattern ablation in cadaver eyes.....	84
5.2.2	Excimer laser smoothing of lamellar keratectomy beds.....	85
5.2.3	Histopathology.....	85
5.4	Results.....	86
5.4.1	Excimer laser pattern ablation in cadaver eyes.....	86
5.4.2	Excimer laser smoothing of lamellar keratectomy beds.....	90
5.5	Discussion.....	94
5.5.1	Conclusion.....	100

CHAPTER 6:

	PHOTOTHERAPEUTIC KERATECTOMY - ORIGINAL CLINICAL STUDIES.....	101
6.1	Introduction.....	103
6.1.1	Aims of the study.....	103
6.2	Methods and study design.....	104
6.3	Results.....	106
6.4	Selected case studies.....	114
6.4.1	Group 1. Rough (uncomfortable/painful) band keratopathy.....	114
6.4.2	Group 2. Smooth (glare inducing) band keratopathy.....	120
6.5	General comments.....	132
6.6	Discussion.....	132
6.6.1	General.....	132
6.6.2	The hyperopic shift.....	134
6.7	Conclusions and patient selection guidelines for PTK.....	135

SECTION IV

THE DEVELOPMENT OF PHOTOREFRACTIVE KERATECTOMY..... 137

CHAPTER 7:

PHOTOREFRACTIVE KERATECTOMY - ORIGINAL CLINICAL STUDIES..... 139

7.1	Introduction.....	140
7.1.1	Aims of the study.....	140
7.1.2	Myopia - the scale of the problem.....	141
7.1.3	Excimer laser photorefractive keratectomy for myopia.....	141
7.2	Human PRK trials - methods and study design.....	142
7.2.1	The laser.....	142
7.2.2	Human studies.....	142
7.2.3	The blind eye study.....	144
7.2.4	The sighted eye study.....	144
7.2.5	Assessment and examination.....	146
7.2.6	Study design - sighted eyes.....	146
7.2.7	The procedure.....	146
7.2.8	Post-operative management and monitoring.....	159
7.2.9	Assessment of aberrations.....	160
7.2.10	Assessment of corneal clarity.....	160
7.3	Results.....	165
7.3.1	The blind eye study.....	165
7.3.2	The sighted eye study.....	165
7.3.3	Post-operative refraction.....	166
7.3.4	Unaided vision.....	172
7.3.5	Best corrected visual acuity and anterior stromal "haze".....	174
7.3.6	Side effects / Complications.....	176
7.3.7	Halo effect (low-illumination positive spherical aberration).....	176

7.4 Discussion.....	179
7.4.1 Study design.....	179
7.4.2 Refractive outcome and regression.....	179
7.4.3 Unaided vision post-PRK.....	180
7.4.4 Stability of refraction.....	180
7.4.5 Sub-epithelial "Haze" - correlations.....	181
7.4.6 The role of topical corticosteroids?.....	184
7.4.7 The "Night Halo" effect.....	184
7.4.8 Autorefraction.....	186
7.4.9 General comments and comparison with radial keratotomy.....	186
7.5 Conclusions.....	187

SECTION V

PHARMACOLOGICAL MODULATION OF WOUND HEALING AFTER PHOTOREFRACTIVE KERATECTOMY.....	189
---	------------

CHAPTER 8:

THE ROLE OF TOPICAL CORTICOSTEROIDS IN PRK.....	191
8.1 Introduction.....	192
8.1.1 Aims of the study.....	192
8.1.2 Topical corticosteroids and corneal wound healing.....	193
8.2 Patient selection and study design.....	196
8.2.1 Pre-operative assessment.....	198
8.2.2 The choice of topical corticosteroid.....	198
8.2.3 The corticosteroid regimen.....	199
8.2.4 The procedure.....	199
8.2.5 Post-operative management / monitoring.....	199
8.3 Results.....	200

8.3.1 Allergic response.....	200
8.3.2 Intraocular pressure (IOP) increase.....	200
8.3.3 Refractive outcome.....	200
8.3.4 Subjective anterior stromal haze.....	204
8.3.5 Objective haze assessment.....	204
8.3.6 The influence of axial length.....	207
8.3.7 Complications.....	208
8.4 Discussion.....	210
8.4.1 Anterior stromal haze.....	210
8.4.2 Axial length.....	212
8.4.3 Refractive outcome.....	212
8.5 Conclusions.....	214

SECTION VI

GENERAL DISCUSSION AND CONCLUSIONS.....	215
--	------------

CHAPTER 9:

GENERAL DISCUSSION AND CONCLUSIONS.....	217
9.1 General comments.....	219
9.1.1 Acceptance of PTK and PRK.....	220
9.2 PRK - A perspective.....	220
9.2.1 Current maximum and mean follow-up.....	220
9.3 Current problem areas.....	224
9.3.1 Amount of myopia and regression.....	224
9.3.2 Night halo effect.....	226
9.3.3 Corneal haze/scarring.....	226
9.3.4 Loss of best corrected visual acuity.....	226

9.3.5 Wound infection and delayed healing.....	229
9.4 Summary.....	229
9.4.1 Results overall.....	229
9.4.2 Current and future developments.....	230
9.4.3 Conclusion.....	231

SECTION VII

REFERENCES AND APPENDICES.....	233
---------------------------------------	------------

REFERENCES.....	235
------------------------	------------

APPENDIX I: Patient background information and consent forms.....	251
--	------------

APPENDIX II: Patient selection criteria arising from the study.....	273
--	------------

APPENDIX III: Publications arising from the project.....	279
---	------------

LIST OF FIGURES (Page number in parentheses)

- 1.1 Radial keratotomy (35)**

- 2.1 The electromagnetic spectrum (45)**

- 2.2 Absorption characteristics versus wavelength (45)**

- 3.1 The shaft of a human hair following repeated exposure to argon fluoride excimer laser radiation (rectangular beam profile) (49)**

- 3.2 The 'mushroom cloud' of ejected molecular fragments following photoablation of the surface of a cadaver cornea by a single pulse of excimer laser radiation (51)**

- 3.3 Photochemical versus thermal beam-tissue interactions (53)**

- 3.4 Surface ablation (diagrammatic) (53)**

- 3.5 Beam cross-section manipulation (diagrammatic) (55)**

- 3.6 Circular ablation in agar gel (55)**

- 4.1 The Summit Technology UV200 Excimer Laser (68)**

- 4.2 The control panel (68)**

- 4.3 Schematic representation of the Summit UV200 excimer laser (71)**

- 4.4 The Helium-Neon aiming beams (71)**

- 4.5 Line diagram illustrating the generation of a step function on the anterior corneal surface (73)**

- 4.6 Photorefractive keratectomy (PRK) - reprofiling the corneal surface (75)**

LIST OF FIGURES (ctd)

- 4.7** Graphs relating attempted dioptre correction, diameter of ablation zone and depth of ablation (77)

- 5.1** Scanning electron micrographs of the surface of human donor corneas after excimer laser irradiation (87)

- 5.2** High power scanning electron micrographs of the ridges created and removed by excimer laser irradiation (89)

- 5.3** Scanning electron micrographs of the corneal surface subsequent to a) surgical lamellar keratectomy; b) and c) excimer laser irradiation (91)

- 5.4** The effect of excimer laser radiation on an unmasked irregular surface (95).

- 5.5** Production of a smooth surface by excimer laser radiation (97)

- 5.6** Ablation of dense calcium deposits embedded within the stroma and projecting from the surface (99)

- 6.1** Patient positioning and alignment (105)

- 6.2** PTK case 1. Rough band keratopathy (115)

- 6.3** PTK case 2. Rough band keratopathy (119)

- 6.4** PTK case 3. Even, diffuse band keratopathy (121)

LIST OF FIGURES (ctd)

- 6.5** PTK case 4. Even, diffuse band keratopathy (123)

- 6.6** PTK case 5. Even, diffuse band keratopathy (127)

- 6.7** PTK case 6. Dense, even band keratopathy treated with overlapping ablation zones in order to clear the entire corneal surface (131)

- 7.1** Ray diagram illustrating the focusing of light rays from a distant object to a point in front of the retina in the myopic eye (140)

- 7.2** Photorefractive keratectomy (PRK) - reprofiling the corneal surface (143)

- 7.3** The procedure (149)

- 7.4** Representative photographs used to characterise and classify corneal haze (161)

- 7.5** Graphs showing the mean change in refraction as a function of time for all 6 treatment groups (-2.00D through -7.00D) (167)

- 7.6** Mean change in refraction with time for patients undergoing -7.00D treatments (169)

- 7.7** Scattergram of attempted versus achieved correction (171)

- 7.8** The magnitude and time course of anterior stromal haze after PRK (175)

LIST OF FIGURES (ctd)

- 7.9** Loss of best corrected Snellen acuity - histogram (174)

- 7.10** Night 'halo' effect - correlations (178)

- 7.11** Anterior segment photographs 6 months after PRK (183)

- 7.12** Diagram showing the optical principle underlying the influence of pupil size on the night 'halo' effect (188)

- 8.1** Mean change in refraction with time following (a) -3.00D and (b) -6.00D PRK (201)

- 8.2** Scattergram illustrating the considerable individual variation post-PRK (203)

- 8.3** Mean subjective haze grading with time following:
(a) -3.00D and (b) -6.00D PRK (205)

- 8.4** Subjective haze versus change in refraction (D) (1/regression) (206)

- 8.5** Mean objective haze grading with time for both reflected (circles) and scattered (squares) signals (207)

- 8.6** Histograms showing change in best corrected visual acuity (all groups) at (a) 6 months and (b) one year (209)

- 9.1** Anterior stromal haze - clinical and histological photographs (225)

- 9.2** Patient satisfaction post-PRK based on a questionnaire study (228)

LIST OF TABLES

I	Characteristics of some of the lasers potentially suited to corneal surgery	44
II	Rough band keratopathy treated by several overlapping ablation zones	107
III	Rough band keratopathy treated with a single 'on axis' ablation zone	109
IV	Other disorders resulting in rough corneal surfaces treated by excimer ablation	109
V	Smooth surface band keratopathy treated with multiple overlapping ablation zones	111
VI	Smooth surface band keratopathy treated with 'on axis' single ablation zones	113
VII	Refraction results before and after ablation (where applicable)	134
VIII	Patient selection criteria for PRK (original study)	145
IX	Schedule of investigations and follow-up for the original sighted eye PRK patients	147

LIST OF TABLES (ctd)

X	Accuracy of photorefractive keratectomy (follow-up 18 months)	172
XI	Unaided vision 18 months after photorefractive keratectomy in those patients in whom the aim was to achieve emmetropia	173
XII	Complications of photorefractive keratectomy at 18 months	177
XIII	Summary of the literature on PRK at the commencement of the corticosteroid study.	195
XIV	Patient selection criteria for the corticosteroid study	197
XV	Mean change in refraction with time following -3.00D and -6.00D PRK: Comparison of steroid and placebo groups	202
XVI	Complications of PRK in the corticosteroid study at 12 months (n=96)	208
XVII	Results of PRK from centres worldwide	221
XVIII	Patient satisfaction following photorefractive keratectomy	227

ABSTRACT OF THESIS

Investigations were carried out - including the first systematic studies worldwide - to evaluate the efficacy and safety of argon fluoride excimer laser corneal surgery. These studies comprised 4 phases :

- A. A laboratory investigation using the laser to smooth irregular cadaver corneal surfaces.
- B. The development and evaluation of phototherapeutic keratectomy (PTK) for the treatment of superficial corneal pathology.
- C. A prospective clinical trial to investigate the efficacy and safety of photorefractive keratectomy (PRK) for the treatment of myopia.
- D. A randomized, prospective, double-masked clinical trial to investigate the role of topical corticosteroids following PRK.

RESULTS

A. CORNEAL SURFACE SMOOTHING

Selective excimer laser photoablation of irregular cadaver corneal surfaces demonstrated that these could be smoothed in a highly precise way leaving a regular surface similar to that of normal cornea.

B. PHOTOTHERAPEUTIC KERATECTOMY (PTK)

25 patients with superficial corneal pathology were treated. A marked improvement in corneal contour or transparency was demonstrated in all patients with corresponding improvement in visual acuity, glare or comfort.

C. PHOTOREFRACTIVE KERATECTOMY (PRK)

120 patients underwent PRK for treatment of myopia. Initial mean overcorrection was followed by regression to an undercorrected endpoint. Regression was greater when higher degrees of myopia were treated. Complications included anterior stromal "haze" (95% of patients), night halo effects (78%), and loss of visual acuity (15%).

D. THE ROLE OF TOPICAL CORTICOSTEROIDS POST-PRK

113 patients received either intensive topical corticosteroid or placebo after PRK. A beneficial effect on refraction, sustained only during the period of administration, was found in the corticosteroid group. No statistically significant difference in anterior stromal haze was demonstrated.

This thesis details the methodology and results for each phase of this study. The discussion sections compare PTK and PRK with traditional methods of superficial keratectomy and refractive corneal surgery, with the aim of assessing the future potential of laser corneal surgery.

ACKNOWLEDGEMENTS

The financial support for my period of full-time involvement in this project (from November 1989 to January 1992) was provided by a charitable trust, The Iris Fund for Prevention of Blindness, and I am deeply indebted to The Iris Fund for this support. I am also most grateful to The Executive Director of The Iris Fund, Mrs Suzanna Burr, who was most enthusiastic in her support of the project at all stages of development. In addition, it was my privilege to be awarded The 1993 Iris Fund Award for contributions made in this field and this award made provision for computing equipment.

I am indebted to my supervisor, Professor John Marshall PhD, Frost Professor of Ophthalmology at St Thomas' Hospital, London and to Mr Malcolm Kerr Muir MRCP,FRCS,FRCOphth, consultant ophthalmic surgeon to St Thomas' Hospital. I owe them both a special thanks for all their time, advice, enthusiasm and encouragement without which the project would not have been possible.

The laser used was an Excimed UV200 excimer laser manufactured by Summit Technology of Waltham, Massachusetts, USA and I am grateful to the company and the engineers who provided technical support throughout.

Sister Anne Welch, Mrs Judith Armstrong SRN, Mrs Ann Patmore and Mrs June Krafft all gave invaluable support in relation to patient management, administration and communication as well as technical and secretarial assistance in the day to day running of the project. I am also indebted to Nicholas Taub and Fiona Warburton, statisticians from the Department of Public Health Medicine at St Thomas' Hospital, for their invaluable assistance with experimental and clinical trial design at various stages of the project - in particular in relation to the double-masked topical corticosteroid trial.

I also thank my wife and children, Dominic, Justin and Matthew, for their tolerance, patience and understanding. I promise to repay, with interest, the time that I have borrowed from them.

SECTION I

INTRODUCTION

CHAPTER 1

CONVENTIONAL CORNEAL SURGERY

1.1 THE STRUCTURE AND FUNCTION OF THE NORMAL CORNEA

The cornea is the transparent, anterior portion of the outer coats of the eye and has a unique structure which is ideally suited to its 2 principal functions :

1. Protection of the contents of the eye and
2. Refraction of light rays to produce a clear image on the retina.

It is circular in outline but appears slightly elliptical because of a more prominent limbus in the vertical meridian, the horizontal corneal diameter being around 12 millimetres (mm) and the vertical diameter 11mm. Average central thickness is around 0.52mm (equivalent to 520 microns where 1 micron = 10^{-6} metres) and peripheral thickness is of the order of 0.70mm (700 microns). The central optical zone is almost spherical with an average radius of curvature of 7.8mm. Outwith this zone there is a progressive asymmetric flattening such that the overall corneal 'shape' is aspheric in order to minimise positive spherical aberration. The anterior corneal surface - the tear/air interface - forms the most powerful refracting element of the eye and accounts for around 80% (+48.00 dioptres - D) of the overall converging power of the eye (approximately +60.00D). The posterior corneal surface - the endothelium/aqueous interface - has a power of around -5.00 D and therefore the net refractive power of the cornea is approximately +43.00D or 70% of the total.

The cornea comprises 5 layers :

1. The surface **epithelium** which is a stratified squamous, non-keratinising epithelium approximately 5 cells (40 to 50 microns) thick. It has 3 main functions : (i) to form a mechanical barrier to microorganisms and foreign material, (ii) to create a smooth 'optically brilliant' surface to which the tear film can adhere, and (iii) to act as a barrier to diffusion of water, solutes and drugs. The epithelium is attached to the underlying Bowman's layer by the hemidesmosomes and anchoring fibrils of its basement membrane. This otherwise strong adherence can be undermined in a variety of pathological conditions leading to the painful recurrent erosion syndrome.
2. **Bowman's layer** is an acellular zone 8 to 10 microns thick beneath the epithelium. Its anterior border is apposed to the basement membrane of the epithelium.

It is a compact layer of fine, irregular, randomly orientated short collagen fibrils which are approximately 2/3 the diameter of the stromal fibrils. Bowman's layer has no regenerative capacity and it is often stated that once this layer has been breached a permanent corneal scar will result.

3. The corneal stroma constitutes approximately 90% of the cornea and consists of collagen fibrils, stromal cells (predominantly keratocytes) and ground substance/matrix. The collagen fibrils provide considerable structural strength and since the stroma has little elasticity the cornea can maintain a relatively constant shape and curvature. The tensile strength of the corneal stroma is high and blunt injury of sufficient force usually leads to rupture of the globe near the optic nerve head, at the equator, or just anterior to the insertions of the extraocular muscles where the sclera is thinnest. A full exposition of the theory of corneal transparency is beyond the brief of this thesis, however, fundamental to one of the principal roles of the cornea, that of the main refracting element of the eye, is the maintenance of its transparency. Transparent structures have uniform density and uniform indices of refraction. This is achieved in the case of the cornea by its avascularity and relative acellularity and the highly regular dimensions and tightly-packed arrangement of the collagen fibrils within the stroma. These fibrils are between 25 and 35nm in diameter (1 nanometre [nm] = 10^{-9} metres), with the larger diameter fibrils nearer the limbus, and are arranged into 200 to 300 layers (lamellae) which run parallel to each other and to the corneal surface. Interlacing lamellae cross each other, at angles less than 90° , in a highly ordered manner. It is thought that, since the interfibrillar distances are of the order of only 30-60nm, which is considerably less than half the shortest wavelengths in the visible spectrum (around 400nm), and since variations in refractive index occur over these very short distances, light scattered by individual fibrils undergoes destructive interference while the remainder passes through the cornea. Any disruption of this arrangement, such as that caused by corneal oedema or the healing of a corneal wound with deposition of new, disorganised collagen, will cause light scatter and loss of transparency.

4. Descemet's membrane is the basal lamina of the corneal endothelium. It is approximately 10 microns thick and, unlike Bowman's layer, it is a discrete structure made of type IV collagen which can be separated relatively easily from the deep stroma. Detachment of Descemet's membrane can occur, for example, during corneal surgery.

5. The corneal endothelium is the innermost layer of the cornea and consists of a continuous monolayer of cells approximately 4-6 microns thick. The cells form a uniform mosaic with a density in a young adult of around 2500-3000 cells/mm². These cells do not, however, have the capacity to divide and following cell death or injury the remaining cells enlarge and migrate in order to fill any defect. The main function of the corneal endothelium is to maintain a relatively constant level of corneal hydration. This in turn allows stability of the critical interfibrillar anatomical relationships described above which are necessary for corneal transparency. The endothelium achieves the relative dehydration of the corneal stroma firstly, by acting as a semi-permeable barrier between the stroma and the aqueous humour and secondly, through a sodium-potassium and bicarbonate active transport pump which is located in the lateral plasma membranes of the cells.

1.2 ESSENTIAL PREREQUISITES OF CORNEAL SURGERY

From the above description of structure and function it is evident that a complex interplay of anatomical, biomechanical and physiological factors exists to promote the strength, transparency and refracting properties of the cornea. Any surgical intervention is likely to interfere with one or more of these factors leading to reduced function. The following 10 aims or prerequisites therefore characterise the ideal corneal surgical procedure and can be considered the, as yet elusive, 'Holy Grail' of corneal surgery :

1. No interference with corneal transparency by scarring or fibrosis
2. No endothelial damage in the short or long term
3. Maintenance of asphericity to minimise aberration
4. No induced corneal distortion leading to regular or irregular astigmatism
5. Maintenance of a perfectly smooth and stable epithelial surface
6. No reduction in corneal integrity and strength
7. The outcome of the procedure should be predictable
8. The outcome of the procedure should be stable
9. The procedure should have proven efficacy
10. The procedure must be safe with no risk of corneal infection or endophthalmitis.

1.3 INDICATIONS FOR CORNEAL SURGERY

The indications for corneal surgery can be categorised as follows :

1. Surface disorders resulting in pain, lacrimation and reduced visual acuity
2. Loss of corneal transparency and reduced visual acuity because of scarring
3. Light scatter from stromal opacities resulting in disability glare
4. Significant corneal distortion and irregular astigmatism
5. Marked corneal thinning/perforation due to systemic disorders, trauma or infection
6. Errors of refraction as a primary indication

Often several of these indications will co-exist, as for example in advanced keratoconus in which there is gross corneal distortion, irregular astigmatism and anterior stromal scarring. In its most advanced form, acute corneal oedema (hydrops cornea) can result causing a marked loss of transparency or, conversely, gross ectatic thinning and ultimately perforation necessitating a tectonic corneal graft as a matter of urgency.

1.4 CURRENT CORNEAL SURGICAL PROCEDURES AND LIMITATIONS

1.4.1 Epithelial debridement and anterior stromal puncture

Corneal epithelial surface disorders such as basement membrane disease can lead to the recurrent erosion syndrome. This condition is characterised by an intermittent spontaneous breakdown of the epithelium which results in an epithelial defect or erosion. As a result the patient experiences pain (which is often severe), reflex lacrimation, redness, photophobia and reduced visual acuity because of the loss of the normally smooth refracting surface. Attempts at surgical correction of this condition have included epithelial debridement and anterior stromal needle puncture to encourage better adherence of the epithelium to the underlying stroma. Microperforations can occur during this procedure and in the majority of cases success is limited.

1.4.2 Superficial keratectomy for band keratopathy

In this condition calcium is deposited initially at the level of Bowman's layer producing a 'ground glass' appearance to the cornea usually within the exposed interpalpebral aperture. This causes reduced visual acuity and disability glare from light scatter. The

condition can be idiopathic or related to raised serum calcium levels in, for example, sarcoidosis, hyperparathyroidism, malignancy or chronic renal failure. It is also seen in eyes that have had chronic inflammation or that have been traumatised (including surgical trauma). Further deposition of calcium can result in a roughened corneal surface with areas of epithelial loss. At this stage the condition can be painful and visual acuity considerably reduced. Traditionally this condition has been treated by mechanical removal of the calcium by scraping with a scalpel blade - a procedure which is made easier by the preoperative application of a chelating agent such as ethylene diamino tetraacetic acid (EDTA). Problems include difficulty in producing a smooth surface and inadvertent keratectomy leading to anterior stromal scarring.

1.4.3 Lamellar keratoplasty for anterior corneal pathology/dystrophies

In this technique a partial thickness disc of anterior corneal tissue is dissected free and replaced with a partial thickness donor 'button' which is sutured in place. The advantages include reduced risk of allograft rejection and the preservation of the patient's own endothelium. The procedure is essentially 'extraocular', since the anterior chamber is not entered, and overall astigmatism post-lamellar keratoplasty is less than that following a penetrating (full thickness) graft. Problems, however, include interface opacities, residual pathology in the deeper layers of the cornea, the possibility of epithelial downgrowth into the interface and infection.

1.4.4 Penetrating keratoplasty

This is reserved for deep central scarring, endothelial dysfunction (for example in aphakic or pseudophakic bullous keratopathy, or Fuchs' endothelial dystrophy), gross ectatic corneal distortion as in keratoconus and corneal perforation following, for example infection or trauma. Depending on the underlying pathology, there is a significant risk of allograft rejection and, in addition, post-operative astigmatism remains a major problem. As with any corneal surgical intervention, and in particular where an intraocular procedure is required, there is a risk of corneal infection and endophthalmitis.

1.5 REFRACTIVE CORNEAL SURGERY

1.5.1 Introduction

Since the cornea is the main refracting element of the optical system of the human eye (see above), relatively small changes in its anterior curvature will produce relatively large changes in the patient's overall refraction. This principle has formed the basis for numerous surgical attempts to correct refractive error - most commonly myopia - but, as is the case with any condition for which a large number of alternative treatments exists, none of these techniques is problem-free. The underlying difficulty which pervades all forms of refractive corneal surgery is that of individual corneal/patient variation in response to the surgery. Where incisional keratotomy techniques are employed, such as radial keratotomy (RK) or astigmatic keratotomy (AK), a graded amount of corneal stroma is incised to a specified depth and the biomechanical properties of the cornea result in a new, for example flatter, anterior corneal curvature (see below). The wound healing that follows produces scars that are neither as strong nor as stable as the original stroma. Even if the incisions could be produced with an extremely high and repeatable precision, the complex changes which are likely to occur in the non-homogeneous corneal stroma could be expected to make the exact outcome impossible to predict.

In addition, it has been a traditional, and entirely reasonable, view that since ametropia, for example myopia, is not a disease and the eye is in other respects entirely normal, refractive surgery of any type must satisfy the 'Holy Grail' prerequisites listed above and in summary must be predictable, effective and above all safe with a low incidence of complications. While, as mentioned above, numerous refractive corneal surgical procedures have been described, only those that have been practised more widely, and their limitations, are discussed.

1.5.2 Radial keratotomy (RK)

To date, the surgical treatment of myopia practised most commonly worldwide has been radial keratotomy, in which deep, radially-disposed incisions are made in the cornea with great care taken, of necessity, to avoid the central optical zone (see figure 1.1 opposite). The weakening of the mid-peripheral cornea results in a relative flattening centrally with a consequent reduction or, in some cases, an elimination of myopia. This technique was first described in the Japanese literature (Sato, 1939) and was popularized in Moscow in

Figure 1.1 Radial keratotomy

- (a) Each linear incision (I) is made using counter-traction at the opposite limbus with the diamond knife (K) moving from the edge of the optical zone to the periphery.

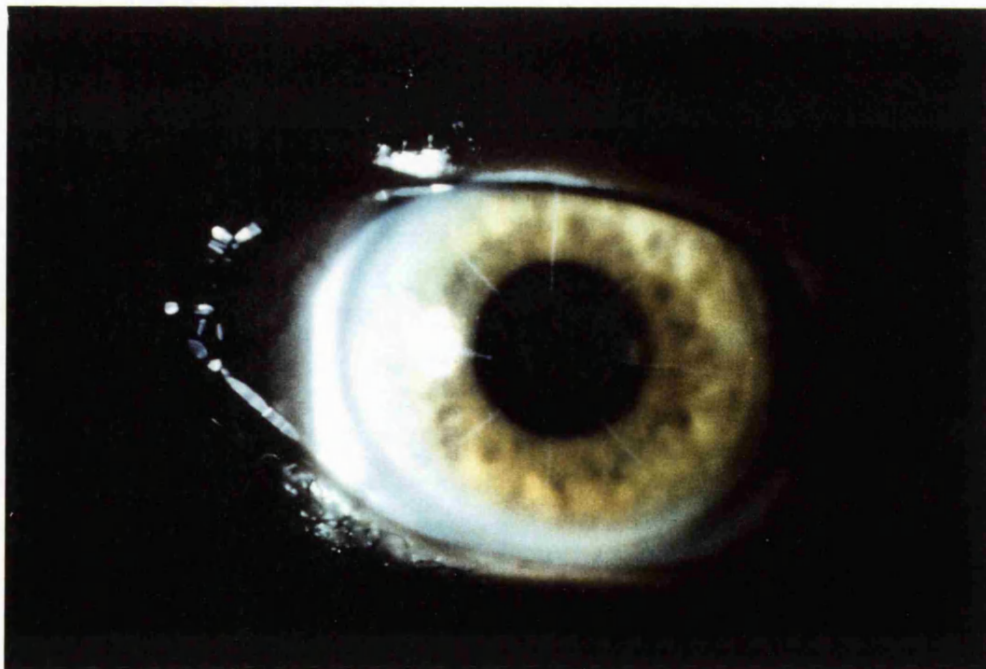
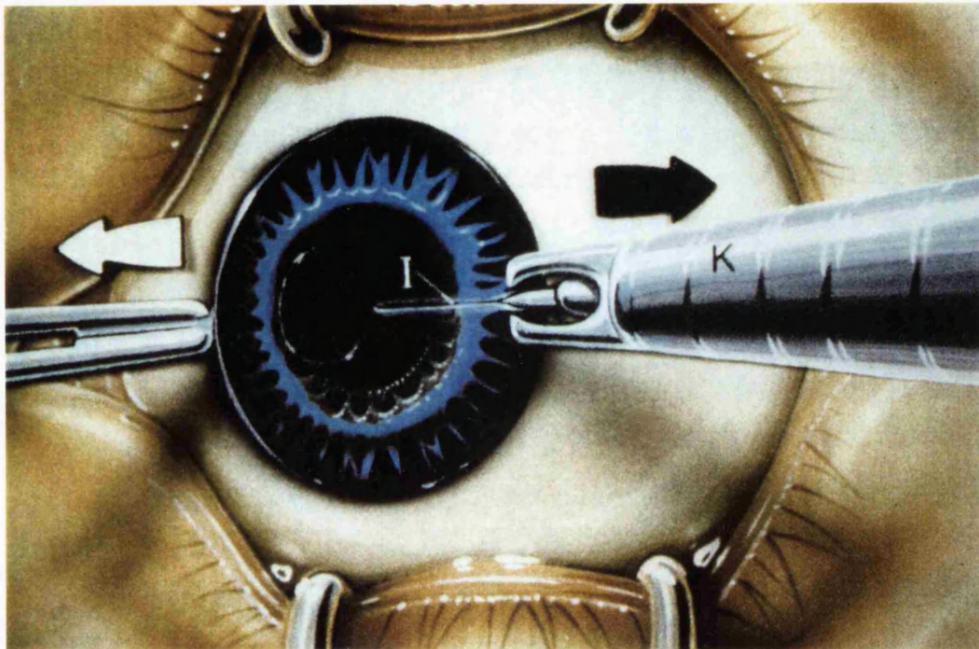

- (b) The corneal appearance following eight-incision radial keratotomy

the early 1970s (Fyodorov and Durnev, 1979). It was first performed in The United States in the late 1970s (Bores et al, 1981) and has been in widespread practice there for over a decade during which time numerous refinements have been made (Waring, 1988). While this technique continues to be popular, complications do occur (Waring et al, 1991). The incisions are made with a diamond knife and in order to achieve a significant flattening effect the surgeon must incise to a depth of around **90 to 95%** of the corneal thickness. Corneal micro- and macro-perforations have occurred resulting in cataract formation (Gelender and Gelber, 1983) and even endophthalmitis (Gelender et al, 1982). The strength and integrity of the cornea is, by definition, affected and keratotomy wounds can rupture following blunt trauma (McDonnell et al, 1987; Binder et al, 1988; Forstot and Damiano, 1988), a complication which has on occasion necessitated enucleation of the eye (Waring, 1992a). In addition, because of relatively poor healing, the wounds produced can be unstable and fluctuation in vision can occur throughout the day as well as over longer periods of time (Macrae et al, 1989). A longer term drift towards hyperopia, which can be most disabling to patients who have known only the myopic state, has been noted in around 1/3 of patients (Waring et al, 1991). The incisions can also scatter light and therefore produce disability glare. Because of these considerations some surgeons consider radial keratotomy to be an irreversible procedure with a significant incidence of potentially serious complications and as such it can not be easily justified in the context of a 'cosmetic/refractive procedure'.

1.5.3 Arcuate keratotomy (AK)

Arcuate relieving incisions can be used to reduce or eliminate corneal astigmatism. Commonly this will be post-surgical astigmatism following cataract or corneal graft surgery. The steepest meridian is identified by refraction, keratometry and/or videokeratoscopy and paired arcuate relieving incisions are usually made, centred on this meridian, at a predetermined distance from, and either side of, the optical centre of the cornea. Their effect is to allow a relaxation of the tissue in the steep meridian as well as a relative steepening of the flat meridian due to an effect termed 'coupling' (Thornton, 1990). Numerous parameters can be varied in an attempt to improve accuracy and predictability, for example, the depth of the arcuate incisions, their angular subtense at the corneal apex and their distance from the optical centre, and several nomograms exist which relate these variables (Lindquist et al, 1986; Lindstrom, 1990). However, for the reasons stated above, the results are relatively unpredictable.

1.5.4 Keratomileusis

In this technique, which was first described by Jose Barraquer, an automated microkeratome is used to remove a partial thickness 'disc' of corneal tissue which is then frozen and cryolathed to a new, predetermined curvature. This lamellar disc is then allowed to thaw and is resutured into the lamellar bed (Barraquer, 1964). The disc can be cryolathed to effect an overall flattening or steepening of the anterior corneal curvature. Again, the main problem relates to the poor predictability of the refractive outcome, although interface opacification and infection can also occur.

1.5.5 Keratophakia

In this procedure, after a superficial lamellar disc of corneal tissue (a 'corneal cap') is removed using a microkeratome as for keratomileusis, a pre-ordered donor lenticule is sandwiched between the lamellar bed and the corneal cap, which is then sutured in place. Positive or negative donor lenticules are available to correct hypermetropia or myopia respectively. The effect on refraction is again due to the altered anterior corneal curvature and the same problems of predictability and interface opacification exist (Waring, 1985).

1.5.6 Epikeratophakia

This technique is similar to keratophakia except that the donor lenticule is sutured directly onto the exposed, smooth surface of Bowman's layer following meticulous epithelial debridement. It was used primarily for cases of unilateral aphakia following the removal of congenital cataracts although negative donor lenticules have also been made available (McDonald et al, 1987a, 1987b). Lack of predictability has led to the almost universal abandonment of epikeratophakia and similar lamellar keratorefractive procedures.

1.6 GENERAL COMMENTS

From the above descriptions it can be appreciated that all current corneal surgical procedures have limitations. These are primarily in relation to the variation in surgical technique, for example, wound edge profiles and final suture tension in penetrating keratoplasty, in addition to the variability of the wound healing response post-surgery. This individual variation is especially relevant in the context of refractive corneal surgery where the criteria of success should, by definition, be more stringent. Because of the inherent limitations in conventional corneal surgery and the relatively poor predictability and potentially serious complications that characterise the above refractive surgical techniques, alternative modalities for the treatment of corneal pathology and refractive error have been sought in an attempt to realise the 'prerequisites of the ideal corneal surgical procedure'.

CHAPTER 2

LASERS IN CORNEAL SURGERY

2.1 THE POTENTIAL OF LASERS IN CORNEAL SURGERY

Since one of the key elements contributing to the difficulty in predicting the outcome of refractive surgical procedures, such as incisional keratotomy, is the inevitable variation in surgical technique from surgeon to surgeon and from patient to patient, it was proposed that lasers might be used to eliminate these variables. It was also hoped that, by altering the corneal shape with laser radiation, greater control over the variability of the wound healing response might be possible. Finally, it was hypothesised that the successful use of laser energy to remove, for example, corneal tissue, could be a major step towards entirely automated or 'robotic' surgery in numerous clinical areas. Several lasers, selected on the basis of their beam-tissue interactions - principally their corneal absorption characteristics, have been investigated in relation to their 'corneal cutting potential'.

2.2 THE BASIC PRINCIPLES OF LASERS

The term "LASER" is an acronym for "Light Amplification by Stimulated Emission of Radiation". While light has both wave-like (refraction, interference) and particle-like properties (beam-tissue interactions) it is the latter which forms the basis of the theory of the generation of laser energy. According to quantum theory, which was originally put forward by Albert Einstein in 1905, optical radiation consists of discrete packets or "quanta" of energy termed photons. The energy associated with these emitted photons is related to their frequency or wavelength and therefore the terms 'wave' and 'photon' are often used interchangeably depending on the phenomena under discussion.

The electromagnetic spectrum is composed of a broad range of wavelengths, from long radio waves to short gamma waves, and each wavelength can, theoretically, interact with the cornea in a characteristic way. For example, the cornea absorbs ultraviolet and infrared radiation well but transmits radiation of wavelength lying in the range between approximately 400 and 1400 nanometres (1 nanometre [nm] = 1×10^{-9} metres).

Important characteristics of laser light include :

2.2.1 Monochromaticity

Laser light is almost monochromatic, that is, the emitted radiation has a single wavelength. In reality pure monochromaticity is difficult to achieve and the radiation comprises a discrete, narrow range of wavelengths. It is this characteristic which determines absorption or transmission of the radiation by the cornea.

2.2.2 Directionality

Laser light has very little divergence, or spread, following its exit from the laser cavity and is essentially collimated. A small spot of laser light can, therefore, be directed accurately, without deviation or loss of intensity, over relatively long distances.

2.2.3 Intensity/brightness

The intense brightness of laser light is an expression of the energy contained within the beam. These energies are extremely high because of the concentration of a single wave train moving in a single direction. This energy, when absorbed by the cornea, can lead to removal of tissue. Radiant energy is measured in Joules/cm² and the irradiance in Watts/cm².

2.2.4 Coherence

This occurs when laser light waves are 'in phase' - a condition that is met when there is a constant correlation between the peaks and troughs of the waves. The coherence of light from lasers used for corneal surgery is, however, generally very poor.

2.2.5 Mode structure

This term refers to the distribution of energy within the laser beam and can be defined further as the energy distribution, or energy profile, of the beam in cross-section (transverse mode), or along its length (longitudinal mode). Excimer lasers produce a multi-mode beam that is more difficult to render homogeneous compared with solid state or dye lasers. This characteristic is of considerable importance in relation to the potential application of excimer laser radiation in corneal refractive surgery - especially for 'wide area reprofiling' (photorefractive keratectomy or PRK, see below).

2.3 THE PRODUCTION AND EMISSION OF LASER LIGHT

There are 3 basic requirements for the production of laser radiation :

2.3.1 An active 'lasing' medium

This is a collection of atoms, molecules or ions that emit radiation in the optical part of the electromagnetic spectrum. This medium could be a gas (eg carbon dioxide) or a combination of gases, a solid crystal (eg Neodymium-Yttrium Aluminium Garnet or Nd-YAG) or a liquid as in tunable dye lasers.

2.3.2 An energy source

A source of energy is required to allow the population of atoms within the lasing medium to undergo a transition from their 'ground state' to a higher energy level (population inversion). This part of the process has been termed 'pumping'.

2.3.3 An optical resonator

This usually takes the form of 2 mirrors at opposite ends of the laser cavity - which cause the emitted light beam to be reflected back and forth stimulating other atoms to a higher energy level and therefore amplifying the light to create a much more powerful beam upon its final exit from the laser.

Laser light is emitted either continuously or in pulses. With continuous wave (CW) lasers, a constant pumping of the lasing medium leads to a stationary emission of light (eg the Argon laser used for retinal photocoagulation). In the case of pulsed lasers, excitation of the lasing medium is achieved by single events, for example an electrical discharge, which in turn leads to a single, short emission or pulse of laser light (eg the Nd-YAG laser). The power of a pulsed laser can be as much as 10^6 times greater than the continuous wave lasers and only pulsed lasers have found application in corneal refractive surgery.

2.4 INTERACTION OF LASER LIGHT WITH THE CORNEA

There are 4 ways in which laser light can interact with the cornea : transmission, scattering, reflection and absorption. Which of these 4 predominates varies and depends upon the characteristics of the individual laser. Transmission of laser light through the normal human cornea occurs generally between 400 and 1400nm. Laser light can also be scattered by the tissue, if a large area is exposed, with a concomitant reduction in efficiency as more energy is converted to heat. Reflection of the beam is insignificant and of no relevance in the context of surgical applications while absorption is the most important of the 4 possible interactions and is the basis upon which lasers have been selected as potentially suitable for corneal surgery. The greater the absorption of laser radiation by tissue such as the cornea, the less the penetration into the tissue. Lasers ideally suited to corneal surgery are those in which absorption is high since, with limited penetration beyond the corneal surface, there is a large safety margin in relation to deeper ocular structures such as the corneal endothelium and crystalline lens. The greatest absorption in the cornea is by macromolecules in the far ultraviolet portion of the electromagnetic spectrum (less than 300nm) and by water in the middle (3000-6000nm) and far (greater than 10,000nm) infrared regions (see figures 2.1 and 2.2 opposite). Table I below defines lasers that have been used for keratectomy in terms of the penetration depth of the emitted radiation and it can be seen that the argon fluoride excimer (193nm) laser and the 5th harmonic Nd-YAG laser have least penetration, or maximum absorption, and therefore would seem to be best suited, theoretically, to corneal surgery.

Table 1 Characteristics of some of the lasers potentially suited to corneal surgery

Laser type	Wavelength (nm)	Pulse duration (nsec)	Penetration depth (microns)
Excimer (ArF)	193	10-20	2-3
Excimer (KrF)	248	10-20	10
Excimer (XeCl)	308	10-20	300
Nd-YAG 5th harmonic	213	10	2
Holmium YAG	2060	20,000	330
HF	2870-2910	50	1.5
Erbium-Yag	2940	20,000	0.75
Raman shifted YAG	2800	10	1.5
CO ₂	10,600	-	-

(courtesy of Professor George Waring MD)

Figure 2.1 The electromagnetic spectrum. The visible portion (approximately 400nm to 700nm) is 'exploded'. The argon fluoride excimer laser emits at 193nm in the ultraviolet 'C' portion of the spectrum.

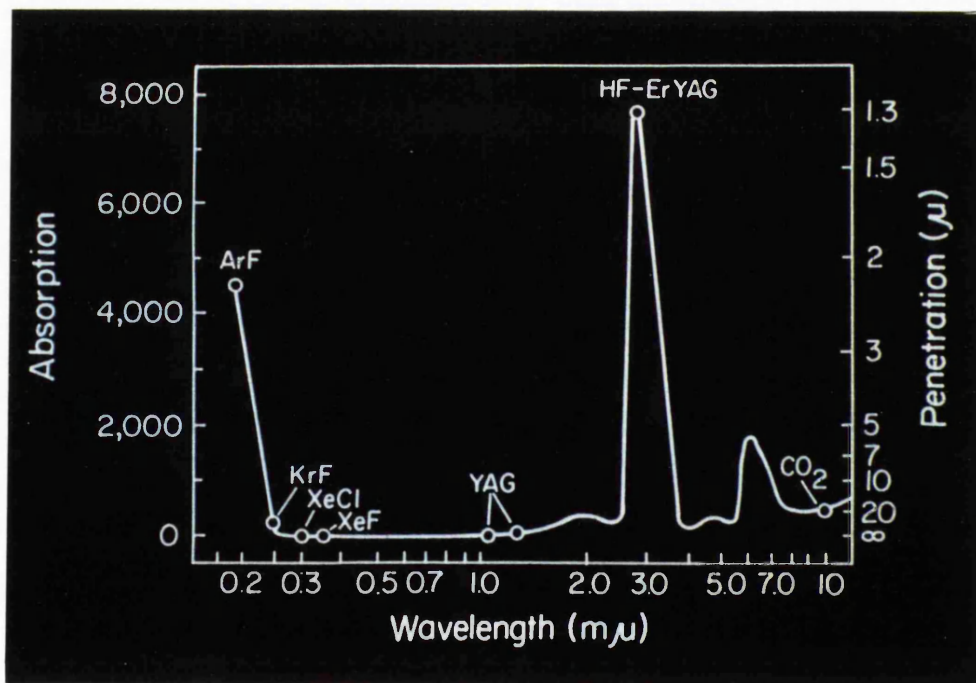
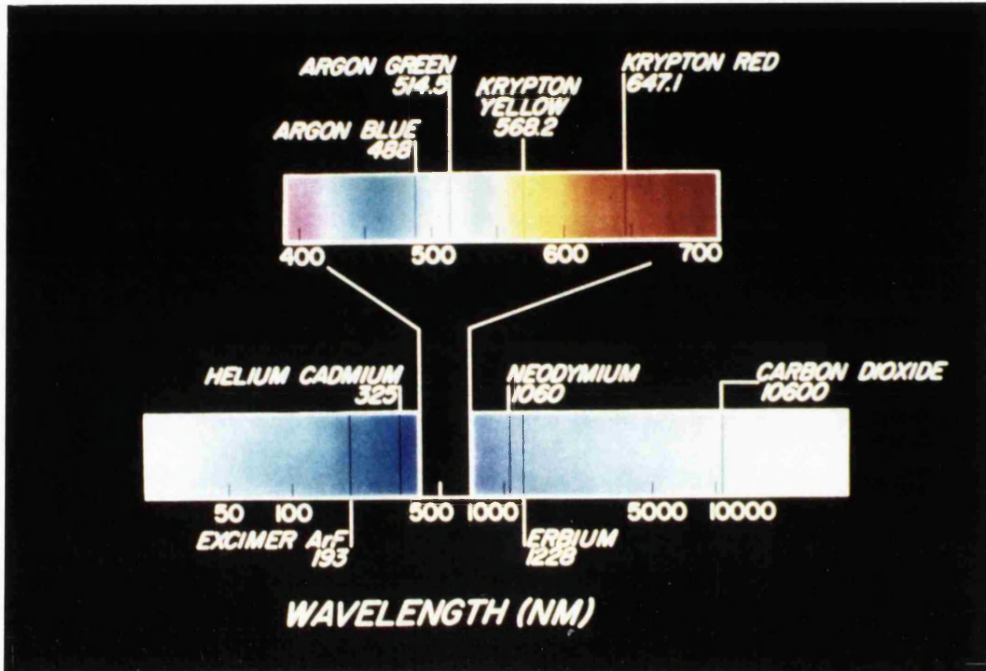

Figure 2.2 Absorption versus wavelength (nm). Radiation from the argon fluoride excimer and the Erbium-YAG lasers have high absorption within the corneal surface (therefore low penetration)

2.5 HISTORICAL OVERVIEW OF LASER CORNEAL SURGERY

The continuous wave (CW) carbon dioxide (CO₂) laser, which has an emission wavelength of 10,600nm (10.6 microns), was the first laser to be investigated for its possible role in corneal surgery (Fine et al, 1967). This followed from its original description in 1964 (Patel, 1964). However, although it was shown to be capable of vaporising corneal tissue, the amount of energy required to create corneal incisions caused significant charring and burning of adjacent tissue. Pulsed exposures were then utilised to allow less dissipation of heat and hence less thermal damage (Beckman et al, 1971) and the total energy exposure was then reduced further by using Q-switching (Keates et al, 1981). This restricted the unwanted charring at the incision site to a surrounding margin which was only 25 to 30 microns in width. In spite of these improvements however, the CO₂ laser was abandoned as a tool for corneal surgery and other lasers, such as the Hydrogen Fluoride (HF) laser and the Erbium-YAG laser, with higher absorption characteristics, less thermal damage and therefore greater accuracy, were evaluated.

The first application of the Erbium-YAG laser for corneal ablation was reported in 1986 (Esterowitz et al, unpublished work, paper presented at the Conference on Lasers and Electro-Optics, San Francisco, 9-13 June, 1986). In the same year it was demonstrated that the pulsed HF laser (wavelength = 2.7 to 3.0 microns) could vaporise corneal tissue and produce well-defined incisions beyond which there was a zone of thermal damage only 1 to 15 microns wide (Loertscher et al, 1986; Seiler et al, 1986).

In the 1970s pulsed far-ultraviolet lasers (excimer lasers), capable of removal of material from an exposed surface with an unprecedented degree of accuracy, were developed for industrial use and, with their proposed clinical application in the mid-1980s, the role of lasers in corneal surgery entered a new era.

CHAPTER 3

THE DEVELOPMENT OF EXCIMER LASER CORNEAL SURGERY

3.1 BACKGROUND

Excimer lasers were first developed in the mid-1970s for use in the manufacture of printed circuitry (Searles and Hart, 1975) and investigation into their potential use in ophthalmic surgery followed reports from scientists in both the health sciences and electronics fields. It was noted that far-ultraviolet excimer laser radiation could be used to 'photo-etch' highly precise, well-defined, lines in plastic surfaces (Srinivasan and Mayne Banton, 1982; Andrew et al, 1983; Garrison and Srinivasan, 1985; Rice and Jain, 1984; Deutsch and Geis, 1983). At lesser intensities, the excimer laser radiation could be used to produce surface markings in corneal epithelium (Taboada et al, 1981) or even remove discrete blocks of tissue from, for example, the shaft of a human hair (see figure 3.1 below) (Dyer and Srinivasan, 1986; Sutcliffe and Srinivasan, 1987). The first suggestion of their application in refractive surgery was made by Trokel, Srinivasan and Braren who argued that since excimer laser radiation could etch highly precise lines in plastics it might be possible to produce incisions in the cornea with an unprecedented accuracy (Trokel et al, 1983).

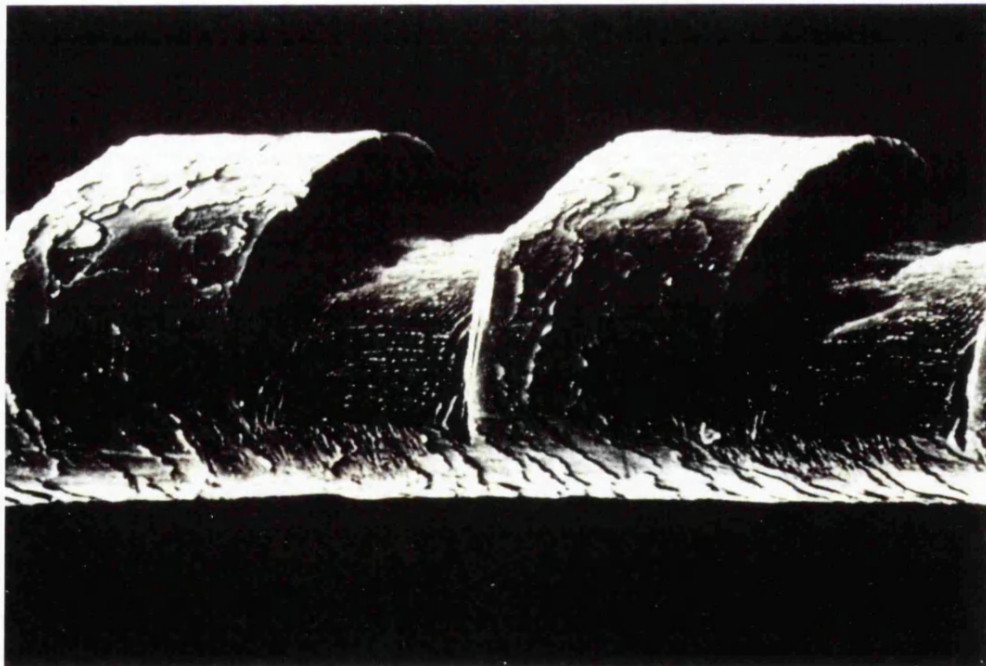

Figure 3.1 The shaft of a human hair following repeated exposure to argon fluoride excimer laser radiation (rectangular beam profile). Blocks of keratin have been excised along the hair shaft with remarkable precision to leave smooth, perpendicular sides. The base of each cut segment has a similar contour to that of the surface of the hair. (photograph courtesy of Dr R Srinivasan)

3.2 THE LASING MEDIUM AND BEAM-TISSUE INTERACTIONS

The term EXCIMER, first coined in 1960, is an acronym, or more accurately a conflation, of the term 'excited dimer' which describes an energised molecule with 2 identical components. These molecules comprise the lasing medium within the laser cavity and therefore the term 'excimer' is used in the same way that the terms 'ruby', 'krypton', CO₂ and 'YAG' (yttrium, aluminium & garnet) are used to describe the crystals or gases which produce the laser radiation in these respective clinical lasers. 'Excited dimers' are two atoms of an inert gas, in this case argon, bound in a highly unstable form with atoms of a halogen such as fluorine to produce 'diatomic rare gas halides'. Argon, being an inert gas would not normally interact with fluorine, however, because of the high-energy electrical discharge within the laser cavity, the electrons are moved to a higher energy state, the atoms become 'excited' and an unstable argon-fluoride diatomic rare gas halide is formed. The significance of this particular combination of atoms lies in the high energy associated with these very unstable bonds. After diatomic rare gas halides are formed within the laser cavity these dimers dissociate and very high energy photons are released at a wavelength of 193 nanometres (Hecht, 1983).

The characteristics of the emitted radiation at this particular wavelength provide the first of the 2 key elements of Argon Fluoride excimer laser radiation which make it eminently suitable for corneal surgery - the precision with which corneal tissue can be removed. The emission wavelength of 193nm is in the ultraviolet C portion of the electromagnetic spectrum and at this wavelength the individual photons emitted have exceptionally high peak energy values - of around 6.4 electron volts. Since this value exceeds the binding voltages of carbon-carbon bonds, for example the bonds between biological molecules (which are of the order of 3 electron volts), on exposure to excimer laser radiation these molecular bonds in, for example, the corneal surface are broken and the resultant fragments are ejected away from the surface at speeds in excess of 2000 metres per second (see figure 3.2 opposite). In addition, since a single absorbed photon may lead to bond breakdown, potentially the entire laser beam can be utilised in the 'tissue removal process' (Marshall et al, 1986b; Marshall, 1988). Ultraviolet radiation in this spectral domain does not, however, propagate well in air and at any biological interface the high energy photons are virtually all absorbed within a few microns of the surface. Energy penetration into the tissues is, therefore, extremely limited to around only 3 microns

Figure 3.2 The 'mushroom cloud' of ejected molecular fragments following photoablation of the surface of a cadaver cornea by a single pulse of excimer laser radiation. The fragments leave the surface at speeds in excess of 2000m/s.
(figure courtesy of Dr Carmen Puliafito)



(Krueger and Trokel, 1985; Puliafito et al, 1985) - the average central corneal thickness being 520 microns by comparison. The process, which is one of photochemical or photoablative decomposition, has been termed **PHOTOABLATION** and the removal of tissue is restricted to an infinitesimally thin surface layer with each emitted pulse (figures 3.3 and 3.4 opposite). Of equal importance is the fact that collateral damage to unexposed areas is strictly limited to a zone of thermal damage and condensate of only around 100 to 300nm microns beyond the photoablated area (Puliafito et al, 1985; Marshall et al, 1985). Tissue removal from the corneal surface can be achieved therefore with an unprecedented precision.

The second key element of excimer laser radiation which makes it eminently suited to corneal surgery is its relatively wide beam which can be configured in almost any cross-sectional shape, for example rectangular (fig 3.1) or circular (fig 3.2 and 3.5 overpage). Tissue removal induced by other clinical lasers is achieved by concentrating laser energy into a focused point. However, the Excimer laser beam has a large cross-sectional area and since, as mentioned above, every photon in the beam has the potential to produce tissue change (Marshall et al, 1986b) the entire cross section of the beam can be utilised. Thus, with each laser pulse a layer of tissue only a few molecules thick will be photoablated from the surface. The initial 1 cm by 2 cm rectangular excimer laser beam profile is adjusted by cylindrical quartz lenses and the resultant square, or 'top hat' energy profile of the beam can be made circular by passing the emergent beam through an aperture (Marshall et al, 1986b). This ability to photoablate large areas of cornea with great precision permits selective and graded removal of tissue to induce a refractive change. In practice, beam delivery is more easily configured to remove more tissue from the central cornea and progressively less towards the periphery resulting in a flatter corneal surface profile. By reducing anterior corneal curvature a treatment of myopia is possible. The reprofiling procedure has been termed photorefractive keratectomy or PRK (Marshall et al, 1986b; Munnerlyn et al, 1988; Tuft et al, 1987; McDonald et al, 1990; Gartry et al, 1991; Seiler and Wollensak, 1991). Slit and rectangular excisions can be achieved as well as the circular excisions presently used clinically for photorefractive keratectomy (PRK). In addition, the term 'excision' in relation to excimer laser photoablation is preferred since tissue is removed rather than pushed aside or 'incised' as would be the case if a diamond or steel scalpel blade was used.

Figure 3.3

Photochemical versus thermal tissue interactions defined by wavelength. At shorter wavelengths beam-tissue interactions are characterised by photochemical processes (for example, photochemical decomposition or **photoablation** in the case of the argon fluoride excimer laser at 193nm. Penetration of energy into the tissue (depth) is severely limited at this end of the spectrum.

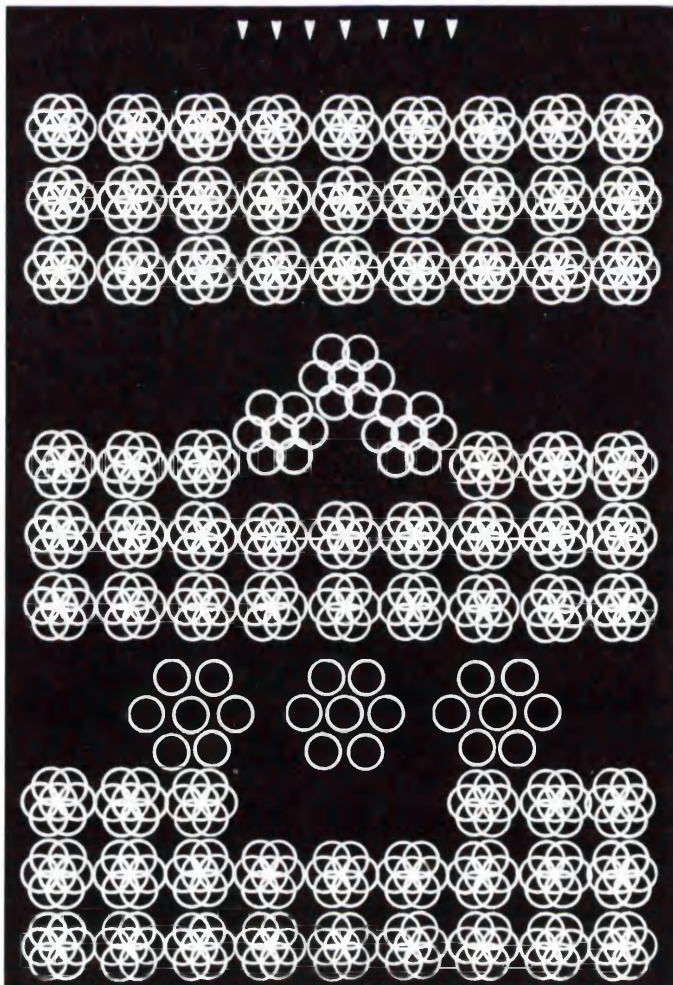
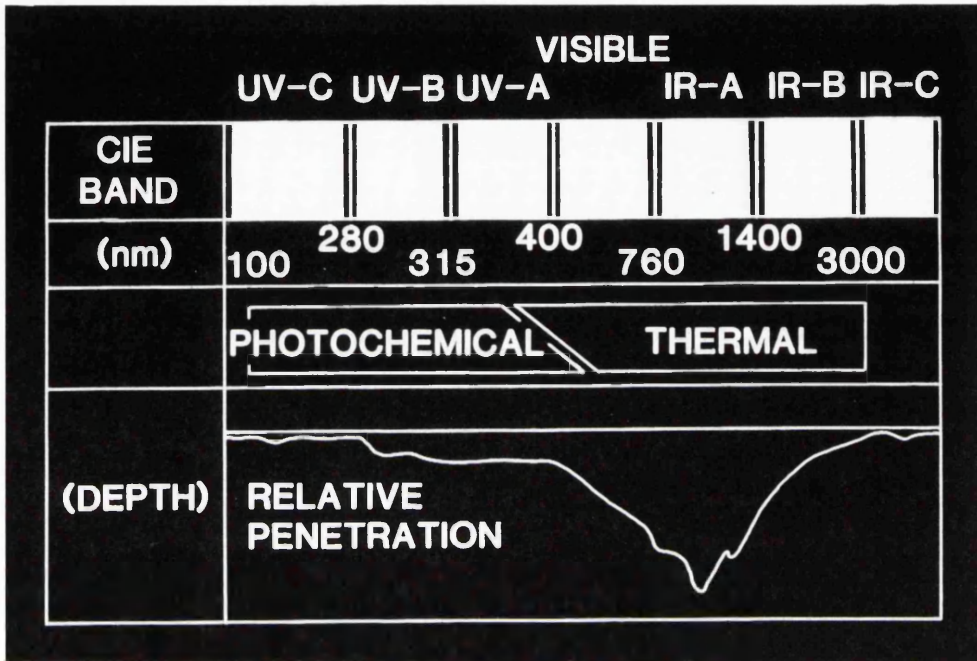

Figure 3.4

As photons of excimer radiation reach the corneal surface their energy is absorbed by molecular bonds within the surface which are broken. The resultant fragments expand away from the surface at high speeds (see also figure 3.2)

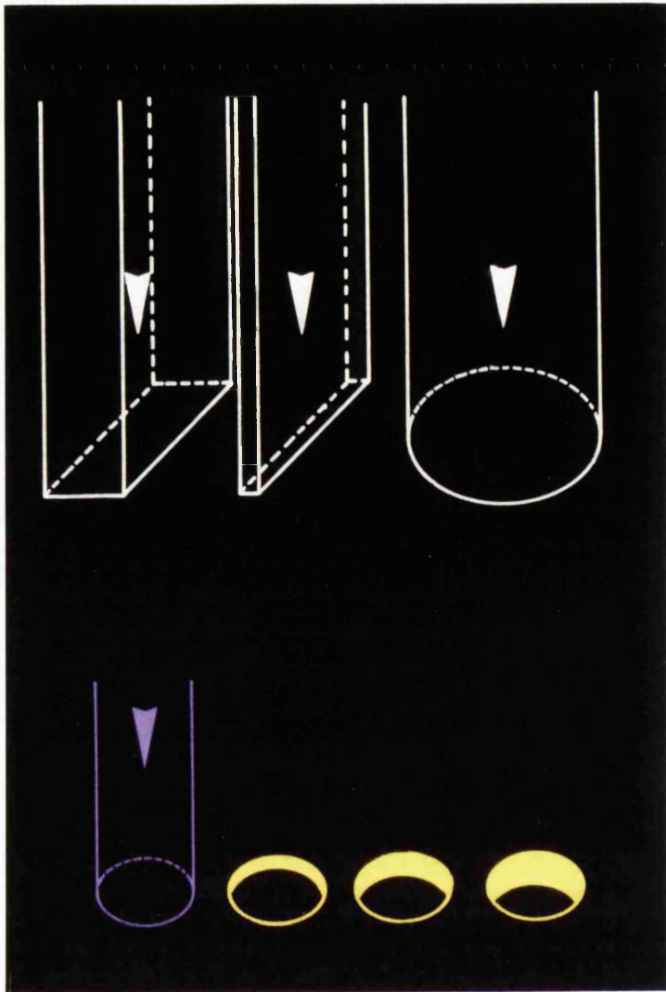

Figure 3.5

The excimer beam can be configured in any cross-sectional shape. Examples represented here diagrammatically are a rectangle, a slit and a circle. With each successive pulse of, for example, a circular cross-section beam, a layer of surface molecules is removed. With repeated pulses over a period of time a circular 'crater' is produced.

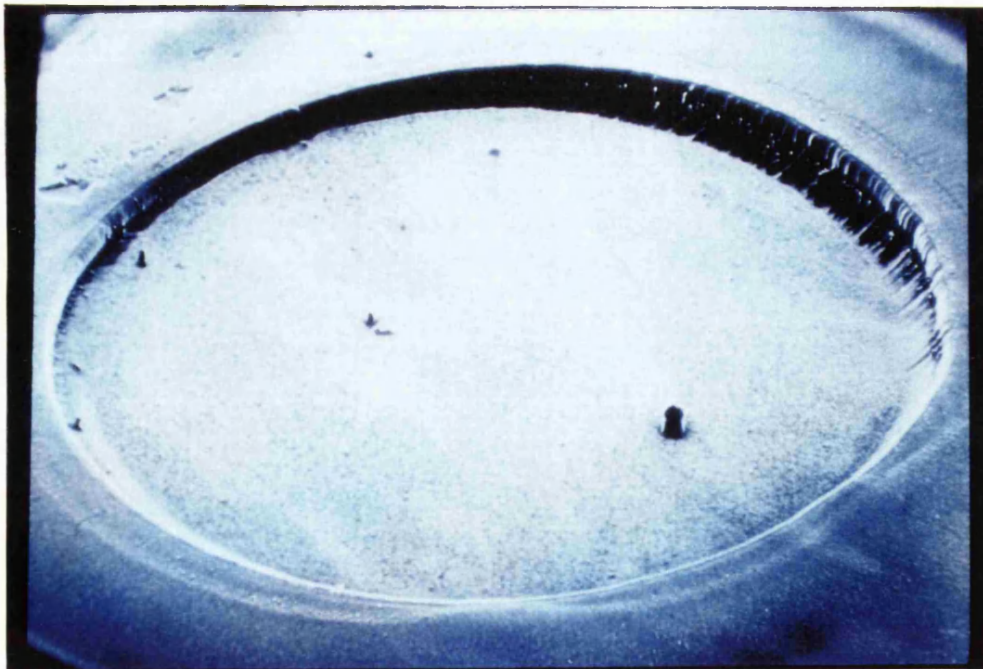

Figure 3.6 This scanning electron micrograph shows a photoablated crater in agar gel (in a Petri dish). The smooth base of the crater is evident (with the exception of a few surface projections caused by debris in the path of the beam, which were more resistant to photoablation than the agar).

3.3 HAZARDS OF EXCIMER LASER RADIATION

As described in chapter 1, any corneal surgical procedure should be evaluated in relation to the following list of essential prerequisites:

1. No interference with corneal transparency by scarring or fibrosis
2. No endothelial damage in the short or long term
3. Maintenance of asphericity to minimise aberration
4. No induced corneal distortion leading to regular or irregular astigmatism
5. Maintenance of a perfectly smooth and stable epithelial surface
6. No reduction in corneal integrity and strength
7. The outcome of the procedure should be predictable
8. The outcome of the procedure should be stable
9. The procedure should have proven efficacy
10. The procedure must be safe with no risk of corneal infection or endophthalmitis.

This list can be distilled into 4 key elements :

1. Safety
2. Efficacy
3. Predictability
4. Stability.....

and above all, prior to the onset of clinical trials to evaluate excimer laser corneal surgery, it was essential for all possible problems relating to safety to be investigated fully. In assessing the safety of laser corneal surgery the main concerns relate to the nature of and, in particular, the **penetration** of the wavelength under investigation. While it has been established that the principal beam-tissue interaction of excimer laser radiation at 193nm is photoablative decomposition, or photoablation, of the corneal surface (see above), concern has been expressed in relation to **secondary fluorescence** since longer wavelengths would have increased penetration into the ocular tissues. Studies were undertaken therefore to assess the possible effect of excimer laser radiation on ocular structures deep to the corneal surface such as the corneal endothelium and the lens. Damage to these structures would lead to **corneal decompensation** and **cataract formation** respectively. In addition, potential problems in relation to the **acoustic shock**

waves generated by the process of photoablation at each acoustic interface within the eye, the release of toxic free-radicals at the site of photoablation, and mutagenesis have been addressed.

3.3.1 Penetration of excimer laser radiation at 193nm

It has been shown that the penetration depth of argon fluoride excimer radiation with emission wavelength at 193nm radiation is of the order of only 3 to 4 microns (Marshall et al, 1986). However, for excimer lasers emitting at 248nm this value exceeds 25 microns (Marshall et al, 1986) and at 308nm it may be as high as 100 microns (Berlin et al, 1988; Seiler et al, 1988b). These observations support previous studies using broad-band sources of radiation which showed that penetration depth increased with wavelengths between 100nm and 400nm (Seiler et al, 1988b). This inverse relationship in the ultraviolet portion of the electromagnetic spectrum between wavelength and absorption, and, in particular, the peak absorption at around 190nm, would suggest that the argon fluoride excimer laser is ideally suited to corneal surgery.

3.3.2 Mutagenesis

During excimer laser corneal surgery, by definition, cell damage occurs as layers of surface molecules undergo photoablation and molecular fragments are ejected away from the anterior cornea at high speed. Where cell damage occurs it has been assumed that there must be the potential for damage to nuclear material with concomitant altered DNA or unscheduled, abnormal DNA synthesis. However, from several independent studies utilising both unscheduled DNA synthesis (UDS) and tissue culture, along with enzyme poisoning techniques, it seems likely that there is little, if any, risk of mutagenesis at 193nm (Trentacoste et al, 1987; Green et al, 1987a and 1987b; Nuss et al, 1987; Kochever I, 1989 and 1991; Gebhardt B et al, 1990; Sliney et al, 1991). This apparent lack of mutagenic response in cells deep to the ablation zone has been attributed to two aspects of the photoablation process. Firstly, that at the fluence used for clinical procedures the absorption of high energy photons results almost exclusively in corneal surface bond-breaking and virtually no photons penetrate beyond the zone of cells damaged by photoablation (Sliney et al, 1991). In addition, it has been estimated that the accumulated ultraviolet dose to the cornea and lens during photorefractive keratectomy (PRK) is less than that necessary to produce photokeratitis on exposure to an unguarded welding arc (Sliney et al, 1991). Secondly, the decreased cytotoxicity and mutagenicity

of 193nm radiation may be due to shielding of the nucleus by cytoplasmic and membrane components or to the formation of different DNA photo-products (Green et al, 1987a and 1987b). It has been calculated, for example, that each micron of cytoplasm attenuates the incident radiation by around 99% (Kochever et al, 1991).

3.3.3 Secondary fluorescence and cataractogenesis

Although complete absorption of 193nm radiation occurs within only a few microns of the corneal surface, target fluorescence during photoablation generates longer wavelength photons, with deeper penetration characteristics. These photons are able, theoretically, to damage intraocular structures such as the crystalline lens. On inspecting the corneal surface during the procedure a faint 'bluish glow' is seen which becomes much brighter when excess surface water undergoes photoablation. Since 193nm radiation is in the 'C' portion of the ultraviolet part of the electromagnetic spectrum it would be completely invisible to an observer. The 'bluish glow' appearance must be due to secondary fluorescence or secondary radiation at around 450nm. In addition, this glow potentially contains the more hazardous portions of the electromagnetic spectrum, between 250 and 350nm, which are known to penetrate more readily into the eye, where they can generate phototoxic and cataractogenic effects (Pitts et al, 1977). A wavelength of around 320nm has been shown to be the most cataractogenic (Pitts et al, 1977).

On biochemical analysis of the aqueous humour and lens of rabbits that had undergone PRK using a scanning laser delivery system (where several thousands of pulses are required) it was found that the concentrations of several markers for cataractogenesis were raised (Costagliola et al, 1994). The energy thresholds for cataract formation at incident wavelengths of 300, 310, and 320nm are 0.5, 1.5, and 15 mJ/cm² respectively (Pitts et al, 1977). In order to achieve optimal photoablation characteristics, argon fluoride excimer laser systems are typically configured to deliver pulses to the corneal plane with energy densities of around 180 mJ/cm². It has been estimated that, maximally, only 10⁻⁵ of the incident energy will be transmitted into the eye as longer wavelengths generated by fluorescence or 're-radiation' (Muller-Stolzenburg et al, 1990). Therefore, of a single excimer laser pulse only 0.0018 mJ/cm² is generated over a large range of the spectrum. Even if all of this re-radiated energy was converted to wavelengths only approaching 320nm, which is not the case, then the exposure levels are still far too low to cause a problem. The best available evidence therefore suggests that the fluorescence

during a single PRK treatment, lasting on average 20 to 30 seconds, is associated with energy levels far below the threshold for UV damage to the lens. In addition, it is likely that this re-radiated energy is insignificant when compared, for example, to a lifetime of exposure to the much higher levels, and broader spectrum, of radiation present in sunlight.

3.3.4 Acoustic shock waves

As emphasised above, ultraviolet radiation at 193nm is absorbed within a few microns of the corneal surface, however in addition to secondary phenomena such as fluorescence, the acoustic shock waves (generated at each acoustic interface) should be considered in relation to deeper ocular structures such as the corneal endothelium. It has been shown that linear laser excisions will cause endothelial damage when they are made to a depth of around 90% of the corneal thickness (Marshall et al, 1985, Dehm et al, 1986). Wide area ablation, although only removing around 10% of the corneal thickness in order to achieve a refractive change, can also be followed by changes in the endothelium such as vacuolation, presumably induced by the acoustic shock waves, although these are shortlived and, at the present time, of doubtful clinical significance (Zabel et al, 1988).

3.3.5 The generation of toxic free-radicals

Similarly, it has been demonstrated that potentially toxic free-radicals can be generated within bovine corneal stroma during excimer laser exposures, although these seem to be transient products which have been demonstrated only in a cryogenic environment (Landry et al, 1994). Although the clinical significance of these studies is yet to be elucidated, it has been hypothesised that these agents might have some effect on the wound healing response following excimer laser PRK.

3.4 THE FIRST CLINICAL APPLICATIONS OF THE EXCIMER LASER

3.4.1 The treatment of corneal scars

Conventional methods for the treatment of superficial corneal pathology have been described in chapter 1 and include:

- (i) A corneal 'scrape' for treatment of band keratopathy with or without the aid of a chelating agent such as calcium edetate (EDTA)
- (ii) A superficial (lamellar) keratectomy alone or
- (iii) A superficial keratectomy with a partial thickness (lamellar) corneal graft.

A corneal scrape to remove calcium deposits is, by definition, a rather uncontrolled procedure in which a scalpel or hockey-ended blade is swept across the cornea in an attempt to dislodge calcium deposits to clear the superficial cornea. The chelating agent helps to 'soften' the calcium layer within the cornea making removal with a blade considerably easier. Nevertheless this remains a rather unpredictable approach and, without care, the resultant corneal surface may be quite irregular following this procedure. For this reason the technique is reserved, in the main, for patients in whom there is a rough corneal surface and considerable discomfort in an eye with limited visual potential. Attempts to remove a smooth layer of calcium, seen more commonly in idiopathic band keratopathy, from the superficial cornea might result in a reduction of best corrected visual acuity due to induced irregular astigmatism. If the corneal pathology is superficial but fails to respond to this technique then a superficial keratectomy might be considered in which a lamellar dissection is carried out with or without a donor lamellar graft to replace the abnormal surface. This is a difficult and time consuming procedure which requires the painstaking dissection of the superficial host cornea and replacement by a similarly dissected donor corneal disc. This donor corneal lamella is then held in position by a continuous 10/0 nylon suture which has to be removed, on average, 2 to 3 months later. Because of the potential of the excimer laser to remove thin layers of corneal tissue in a highly controlled manner it was hoped that it might be used to treat selected corneal pathologies thereby obviating the need for more complex and time-consuming procedures. In 1984 Serdarevic and colleagues were the first to perform a series of successful excimer laser therapeutic lamellar keratectomies in rabbit models to treat experimental candida keratitis (Serdarevic et al, 1984). Their results confirmed that the technique of excimer laser phototherapeutic keratectomy or PTK was not only

feasible but could also be used to eradicate organisms from the cornea leaving the resultant smooth surface to re-epithelialise normally.

3.4.2 Early 'incisional keratotomy' with the excimer laser

As noted above, one of the key advantages of argon fluoride excimer laser radiation (193nm) is the lack of significant damage beyond the exposed area. Ultrastructural examination of corneal excisions in animal models confirmed that these could be produced with a very high degree of accuracy and control. Damage to adjacent unexposed tissue was limited to a zone of only 100 to 300nm beyond the boundary of the photoablated area (Marshall et al, 1985; Puliafito et al, 1985). In non-perforating excisions of varying depths, corneal endothelial damage was noted only when the base of the excision reached to within 40 microns of Descemet's membrane which is similar to, but less extensive than, the effect on the endothelium of diamond knife incisions (Yamaguchi et al, 1981; Marshall et al, 1985; Marshall et al, 1986a; Bende et al, 1988). Furthermore, excimer laser excisions can be controlled precisely in terms of uniformity along the length of a single cut, reproducibility between cuts and in anticipated cut depth (accuracy \pm 3%, diamond knife incisions \pm 12%). The first clinical application was therefore the correction of astigmatism using T-cut excisions (Cotliar et al, 1985; Aron-Rosa et al, 1985 and 1988; Seiler et al, 1988a) which have the same effect as paired arcuate keratomies (see chapter 1). In order to produce linear excisions with the laser it was necessary either to shield the cornea using a mask with slit apertures or limit the beam to a slit cross-section within the delivery system. The resultant 'excisions' were 'V-shaped' in profile rather than discrete linear cuts and were often filled with a 'plug' of corneal epithelial cells (Tenner et al, 1988). It was doubtful whether refractive changes arising from such wounds would be either predictable or stable and in any event masking proved too cumbersome to be practical. Moreover, it could be predicted that the use of excimer laser technology to perform what was essentially a radial keratotomy procedure would not obviate all of the problems of that particular technique. However, each photon within the relatively large cross-section of an excimer beam is capable of bond breakdown and the concept of refractive change by a computer-controlled, direct surface reprofiling, rather than by linear excisions, was put forward in 1986 (Marshall et al, 1986b). The descriptive term for this 'wide area ablation' - **photorefractive keratectomy or PRK** - was adopted at that time (Marshall et al, 1986b).

3.5 AIMS IN THE EVALUATION OF EXCIMER CORNEAL SURGERY

As with any surgical procedure, for corneal surgery with the excimer laser to be accepted in clinical practice an understanding of the nature and quality of wound healing is essential. Complete epithelial wound healing is necessary to re-establish the outer osmotic barrier of the cornea and the optical brilliance of the refracting air/tear interface. Studies have been undertaken therefore to assess latency of wound healing, epithelial migration and adhesion properties, and the presence or absence of epithelial hyperplasia (Tuft et al, 1989). Stromal wound healing has been examined in relation to loss or disturbance of transparency, keratocyte infiltration and scar formation (Marshall et al, 1988; Tuft et al, 1987; Tuft et al, 1989). The corneal endothelium has been assessed in relation to potential cell loss or long-term population changes (Tuft et al, 1989; Dehm et al, 1986). Finally, as discussed above, the putative mutagenic effects of ultraviolet radiation on the cornea have been assessed (Trentacoste et al, 1987; Green et al, 1987a and 1987b; Nuss et al, 1987; Kochever I, 1989 and 1991; Gebhardt B et al, 1990; Sliney et al, 1991). None of these investigations highlighted areas of concern which would have precluded the commencement of our study.

The aims of the study were therefore as follows:

- 3.5.1 To evaluate the efficacy and safety of excimer laser treatment of superficial corneal pathology (phototherapeutic keratectomy - PTK)**
- 3.5.2 To evaluate the efficacy, safety and predictability of computer-controlled corneal surface reprofiling (photorefractive keratectomy)**
- 3.5.3 To investigate the importance of the role of topical corticosteroids in the modulation of wound healing following PRK.**

SECTION II

INSTRUMENTATION

CHAPTER 4

TECHNICAL DESCRIPTION OF THE EXCIMER LASER

Figure 4.1 The Summit Technology UV200 Excimer Laser

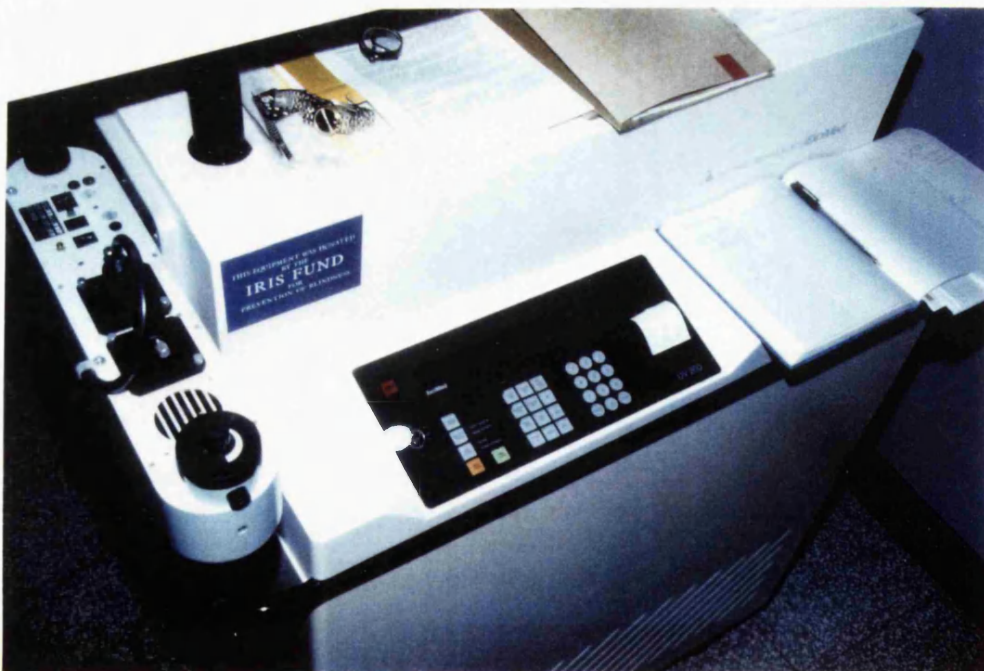
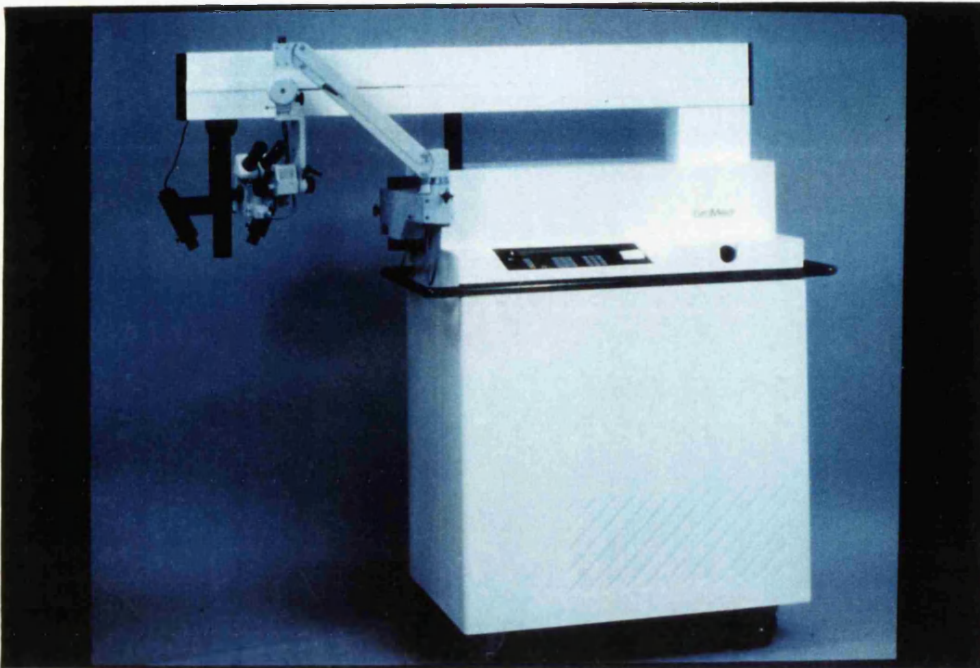

Figure 4.2 The control panel

4.1 PRODUCTION AND EMISSION OF EXCIMER LASER RADIATION

An Excimer UV200 excimer laser (Summit Technology, Waltham, Massachusetts, USA) with a spectral emission of 193nm was used for all studies described in this thesis (see figure 4.1 opposite).

The unit consists of a laser head, a high voltage power supply, and a gas bottle containing a mixture of argon, fluorine, helium and neon enclosed within a gas-tight secondary containment device (SCD). This prevents the escape of these gases should any of the gas lines in the system develop a leak (Sloney, 1991). In addition, the SCD provides electrical noise insulation. The laser operation and power supply are controlled by a microprocessor and the operator interface is by means of a control panel on the front of the system (see figure 4.2 opposite). The delivery of the laser beam is controlled by a set of mirrors, apertures and lenses mounted to a rigid mechanical support. The delivery components regulate the energy and other parameters of the beam.

The laser is powered by a high voltage supply capable of providing 1.5kJ/sec at 32 kV. It requires only a normal mains supply from, for example, a conventional grounded wall socket. The system requires no external cooling or gas connections with the exception of the purge gas (N₂) cylinder. The pulse-forming network of the laser is charged to between 15 kV and 32 kV, the correct voltage being determined by the microprocessor. An energy of approximately 15J is stored in the primary storage capacitor bank of the laser. When the microprocessor 'calls for' a pulse, this energy is switched into the laser discharge by means of a capacitive transfer circuit with a thyatron switch and magnetic pulse compression. The laser cavity is filled with a mixture of argon, fluorine (F₂), helium and neon. The energy density (radiant exposure) of the laser pulse is approximately 180mJ/cm², the duration of the pulse is of the order of 10 nanoseconds (10 x 10⁻⁹ seconds, similar to that of a YAG laser) and the pulse repetition rate is 10 Hz.

Following animal and cadaver eye studies (Kriegerowski et al, 1990; Seiler et al, 1990a) a value for the depth of tissue removed per pulse of 0.22 microns was assumed and this average value was used in the algorithms for corneal surface reprofiling in photorefractive keratectomy (PRK) (Munnerlyn et al, 1988). The beam configuration was circular in cross-section and, for the phototherapeutic keratectomy (PTK) studies described below, it was possible to pre-set the beam diameter between 1 and 4mm.

4.2 THE BEAM DELIVERY SYSTEM

This 'shapes' the excimer beam so that it is delivered to the eye with constant energy, a reasonable uniformity, and a well-determined shape. The beam passes through 2 power monitors: the first located immediately outside the laser cavity and the second at the point at which the beam exits the delivery system near the eye (see figure 4.3 opposite). The readings from these monitors serve as the input to a feedback loop which enables the laser output to be maintained at a constant, predetermined level. This feedback loop ensures that the laser performs reliably and delivers an energy density at the required level to a tolerance of better than ± 20 per cent. In addition, system dynamics are monitored including the efficiency of the optical train and the number of pulses.

The following describes the laser beam path from the laser cavity to the image plane at which it comes into contact with the patient's eye (see figure 4.3 opposite). The beam exits through the partial reflector at one end of the laser cavity. It then travels parallel to the floor until it reaches a 'folding' mirror at which point the beam is redirected to travel upwards perpendicular to the floor. The beam then exits the secondary containment device (SCD) through a 1cm thick fused silica window and reaches a beam splitter. At this point 7 per cent of the energy is directed to the first power monitor in the path. The remaining 93% of the energy continues to a second folding mirror which directs the beam horizontally through beam-shaping optics to a computer-controlled iris diaphragm. The ultraviolet light leaving this iris diaphragm passes through a shutter and is directed downwards by the third and final folding mirror, through a quartz imaging lens, a second beam splitter for the second power monitor, a shutter, and then to the eye. The image plane of the system is defined by the point of intersection of two ancillary helium neon lasers mounted at each side of the laser aperture (see figure 4.4 opposite).

Beam homogeneity is of primary importance in excimer laser ophthalmic surgical applications. The laser is equipped therefore with an iris diaphragm designed to maximize the homogeneity of the beam as it leaves the laser cavity. By the time the beam reaches this iris diaphragm it has an energy profile similar to that of a Gaussian distribution. The iris diaphragm then allows only the central part of the beam, across which the energy profile is most constant, to continue through the system.

Figure 4.3 Schematic representation of the Summit UV200 excimer laser

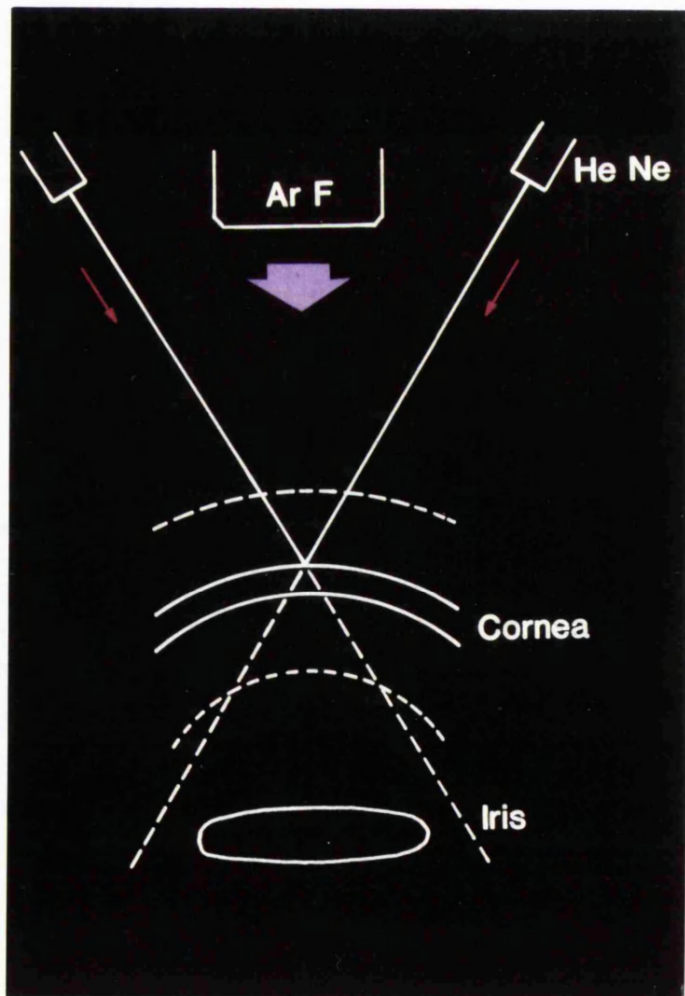
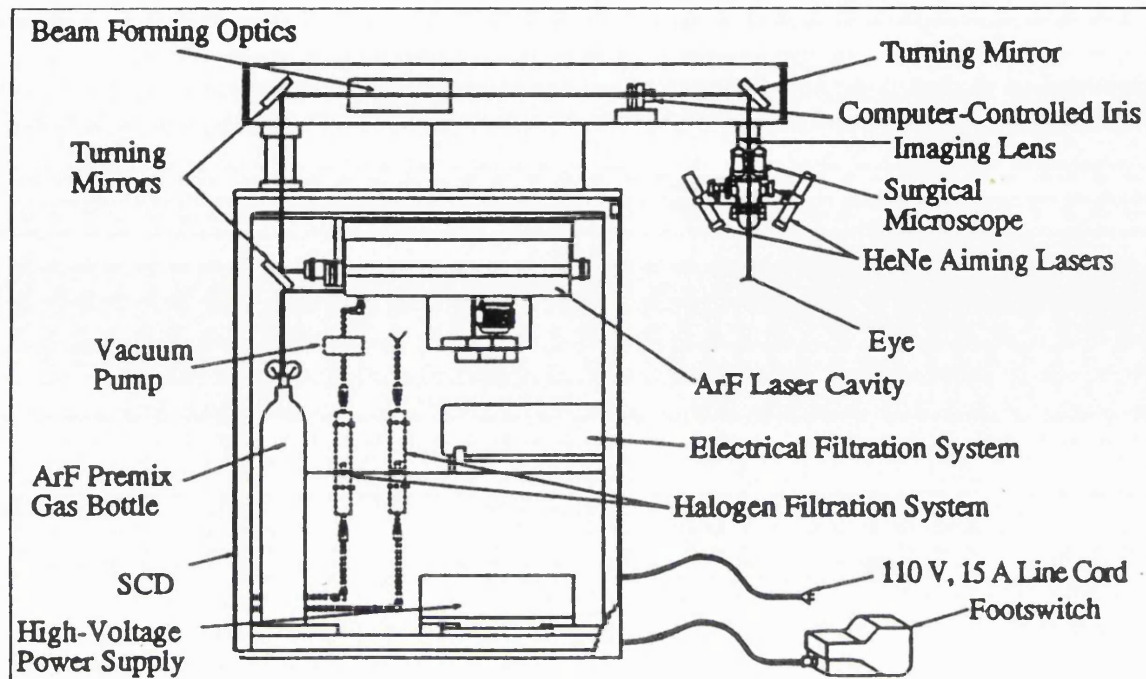

Figure 4.4

Helium-neon aiming beams

The correct energy level is defined by a point within the beam which is around 12cm below the laser aperture.

It is at this point that the 2 helium-neon aiming laser beams are designed to cross in order to facilitate the positioning of the supine patient at the correct height beneath the laser aperture.

While the laser is operating the delivery system is 'purged' with nitrogen (N_2) gas to prevent any energy loss due to absorption, and therefore attenuation, by air, as well as to minimize any accumulation of ozone in the system. The gases within the laser cavity must be replaced regularly from the main storage cylinder within the secondary containment device (SCD). The 'used' gas is evacuated and 'scrubbed' through a halogen filter (to remove residual fluorine) and the gas refill procedure is carried out under microprocessor control.

4.3 PHOTOREFRACTIVE KERATECTOMY ALGORITHMS

To perform photorefractive keratectomy (PRK) the surgeon must enter the desired laser parameters (ablation zone diameter, dioptres to be treated, and ablation rate) into the system using the laser control pad (figure 4.2). The system software then calculates the number of laser pulses needed to perform the procedure. As the laser exposure proceeds during the treatment, the iris diaphragm within the beam path opens progressively until it reaches its maximum diameter (4mm in our studies). Since the central cornea is exposed throughout the procedure, more tissue is removed from this point and progressively less tissue is removed towards the edge of the ablation zone (figure 4.5 opposite). The result is the generation of a 'step function' in the corneal surface (figure 4.6 overpage) and an overall flattening of the anterior corneal curvature. Algorithms which relate (a) the necessary change in corneal curvature required to achieve a given change in refraction to (b) the diameter of ablation zone and depth of ablation, have been devised (Munnerlyn et al, 1988) and form the basis for the software used in PRK. The greater the amount of myopia treated the deeper the ablation. Similarly, ablation depth increases (dioptre for dioptre) when the ablation zone diameter is increased (see figure 4.7 overpage). It was evident from the above considerations that the treatment of high myopia (greater than around -10.00D) would necessitate deep ablations, even using a relatively small 4mm diameter ablation zone, and we elected therefore to set an upper limit of -7.00D, equivalent to an 'on axis' ablation depth of approximately 45 microns, when commencing our PRK studies (Section IV).

Figure 4.5 Line diagrams illustrating the generation of a step function in the anterior corneal surface.

Since more tissue is removed from the centre of the cornea with a graded removal towards the periphery of the ablation zone, the overall effect is a flattening of the anterior corneal curvature. Once the surface re-epithelialises a reduction (or elimination) of myopia follows.

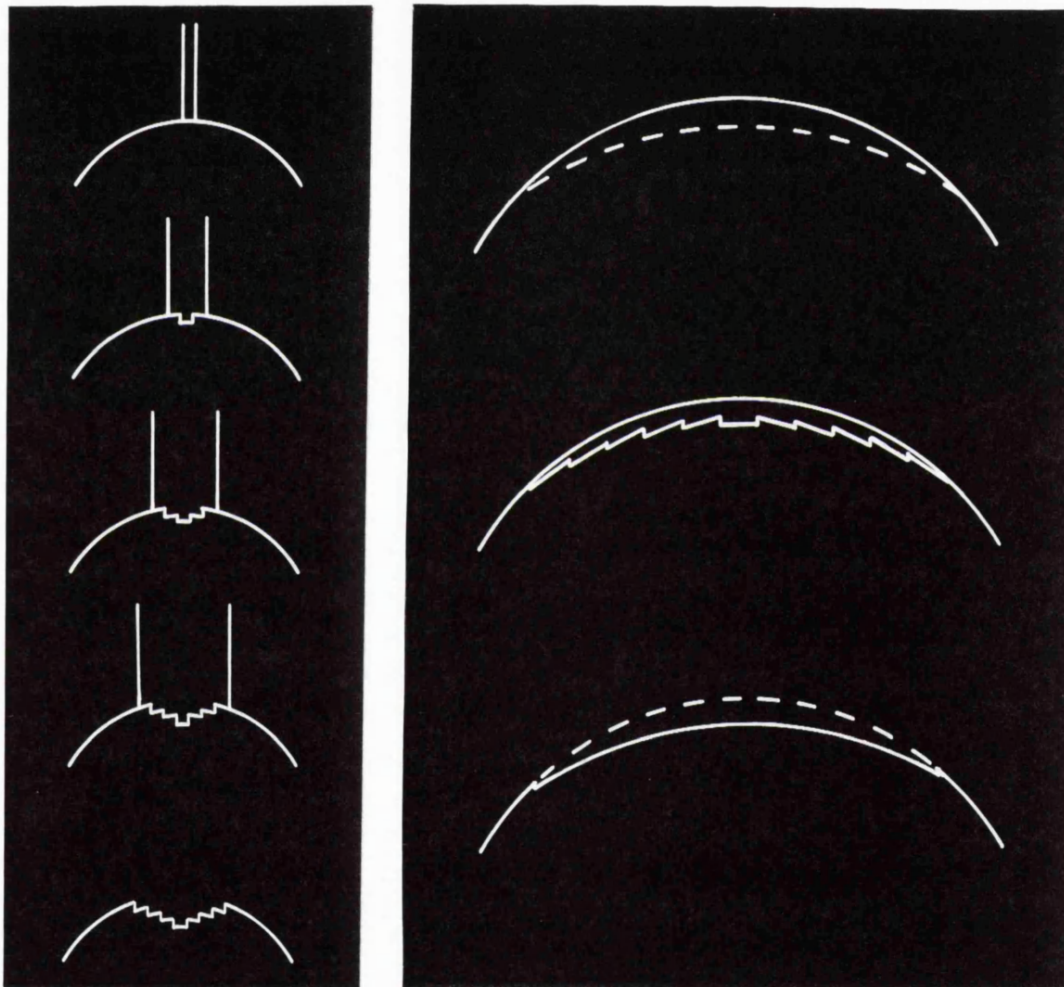

Figure 4.6 Photorefractive keratectomy (PRK) - reprofiling the corneal surface

Scanning electron micrograph of a human cadaver cornea showing the step function produced by repeated pulses of radiation through an expanding iris diaphragm. The bar marker is 500 microns

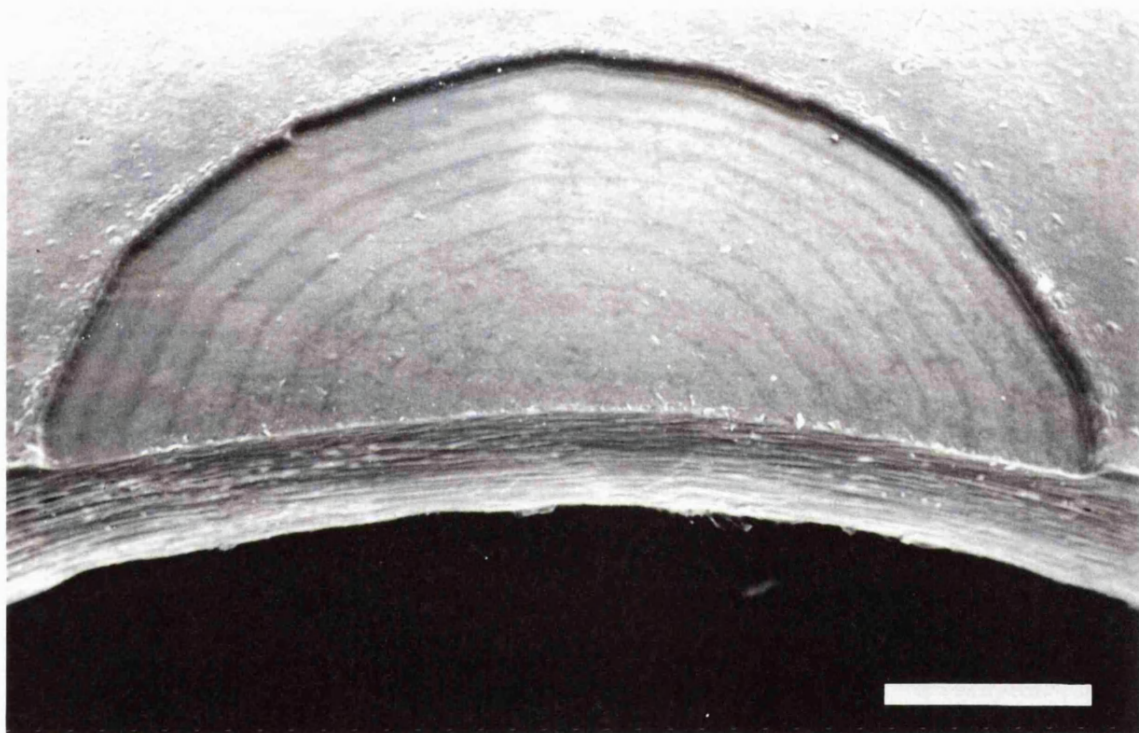
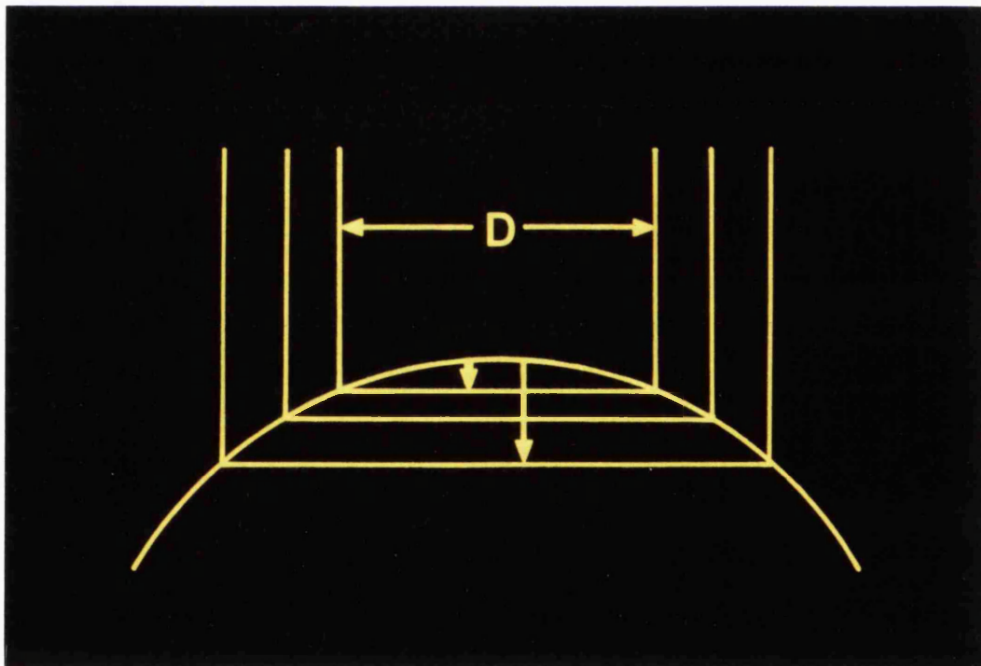
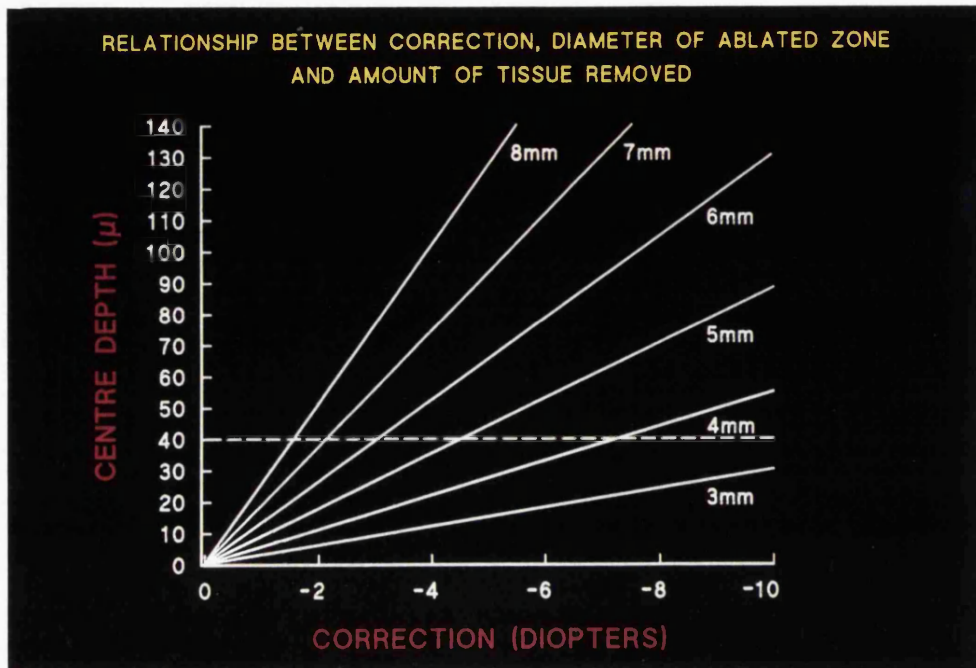

Figure 4.7 Graphs relating attempted dioptrre correction, diameter of the ablation zone and depth of ablation (courtesy of Dr Charles Munnerlyn)



The depth of photoablation (and therefore the amount of tissue removed) required for a given attempted dioptrre correction increases as the diameter of the ablated zone increases. The formula for this relationship is based on a combination of the 'sag' formula and the equation defining the anterior corneal surface power.

SECTION III

THE DEVELOPMENT OF PHOTOTHERAPEUTIC KERATECTOMY (PTK)

CHAPTER 5

LABORATORY MODELS OF EXCIMER LASER CORNEAL SMOOTHING

5.1 INTRODUCTION

5.1.1 Preliminary laboratory evaluation and aims of the study

Prior to the treatment of overt corneal pathology with the Excimer laser it was necessary to elucidate the possible techniques of phototherapeutic keratectomy (PTK) in the laboratory setting. The aim of the first phase of this project (corneal surface smoothing in cadaver models) was to determine whether the laser could be used for wide area ablations to remove opacities and produce an optically smooth corneal surface. Since photoablation occurs across the entire area exposed, it was anticipated that, with repeated pulses, the original surface contour would be reproduced in the base of the ablated disc. It was necessary therefore to devise a means of smoothing an uneven surface. The simplest method of achieving this was to apply a liquid with approximately the same ablation properties as the cornea. The surface tension of the liquid would ensure that any surface irregularities would be negated. If irregularities in the corneal surface had a different ablation rate to that of the surrounding tissue, for example, the dense calcium deposits in band keratopathy, it would be necessary to shield underlying tissue with a liquid while the crystalline peaks underwent ablation.

This chapter describes the use of the excimer laser for the production of large area, optically smooth corneal surfaces in the laboratory.

5.2 MATERIALS AND METHODS

A UV200 Excimer laser (Summit Technology, Waltham, Massachusetts, USA) with an emission wavelength of 193nm, a fixed pulse repetition rate of 10Hz and a fixed radiant exposure of 180mJ/cm² at the corneal plane was used. The system has been described in detail in chapter 4, section II, page 69.

Two main laboratory models of corneal irregularity were used to assess the efficacy of the laser in smoothing non-uniform surfaces :

5.2.1 Excimer laser pattern ablation in cadaver eyes

(a) Smoothing of patterns produced by the laser

The aim of this experiment was to create a geometric irregular surface in cadaver corneas and then to determine whether the excimer laser could be used to smooth these irregularities. Donor eyes were used within 16 hours of death and secured in a Tudor Thomas stand. Intra-ocular pressure, and therefore the shape of the eye, was maintained by injecting normal saline into the vitreous through the pars plana. After removal of the epithelium with a hockey-end blade, the globe was positioned directly beneath the laser aperture and the height of the stand adjusted to bring the helium-neon aiming beams to a single point 'focus' on the centre of the cornea (see figure 4.4, page 71). An area of stroma was masked by placing a piece of bent wire on the corneal surface in the path of the beam. 50 pulses of laser energy were then directed onto the partially occluded corneal surface using a beam diameter of 3mm. This resulted in excavation of the stromal surface in areas not shielded by the wire. In areas directly beneath the wire, ridges of original tissue remained. The next objective was to remove the induced pattern with the laser to restore a smooth surface across the entire ablated zone. The wire was removed and the previously excavated areas "masked" with a 1% or 2% solution of hydroxypropyl-methylcellulose (HPMC : Isoptalkaline, Alcon, UK) or polyvinyl alcohol (PVA : Liquifilm tears, Allergan, UK) to prevent their further ablation. These tear substitutes have a high water content and were assumed to have similar ablation rates to corneal stroma.

(b) Removal of a cylindrical 'facet'

In this experiment the Excimer laser was used to create a cylindrical excavation 1mm in

diameter and 100 microns deep (approximately 1/5 the normal central corneal thickness). The beam diameter was then increased to 3mm, the ablated cylinder filled with 1% HPMC, and the surrounding stromal surface carefully dried. Ablation of the cadaver corneal surface then commenced and was continued until the surrounding stroma had been ablated to the same depth as the original cylinder. In practice this process was monitored by changes in tissue fluorescence to be described in the results section.

5.2.2 Excimer laser smoothing of surgical lamellar keratectomy beds

This experiment was designed to assess the potential of excimer laser radiation, in combination with masking agents, to smooth irregular corneal surfaces similar to those encountered in clinical practice. Surgical lamellar keratectomies were carried out on donor eyes. The initial incision was made with a disposable 6mm trephine and the lamellar dissection was performed using a steel blade and Paufigue's knives beginning, at the base of the trephine cut. HPMC was then applied to the keratectomy bed and its amount and distribution adjusted while multiple overlapping ablation zones were produced until the bed was smooth.

5.2.3 Histopathology

After laser exposure a 5mm penetrating incision into the posterior globe was made and the cadaver eyes were immersed in fixative (2.5% glutaraldehyde buffered in 1M sodium cacodylate with 10mg/ml calcium chloride with pH 7.4). After 24 hours the corneas were prepared for light microscopy (LM) and electron microscopy (EM). Those for scanning electron microscopy (SEM) were post-fixed overnight in 2% osmium tetroxide buffered in 0.1M sodium cacodylate, dehydrated through a series of ascending concentrations of acetone and critical-point dried. Dried samples were sputter-coated with a 30nm layer of gold before examination in a Hitachi 520 scanning electron microscope. For transmission electron microscopy (TEM) specimens were post-fixed for only 1 hour in the osmium tetroxide solution described above, dehydrated in alcohol and then embedded in Araldite (CY212) via epoxypropane. Sections were cut at 1 micron on glass knives for LM and on diamond knives for EM and mounted on 200 mesh copper grids, stained with uranyl acetate and lead citrate before examination in an AEI 801 transmission electron microscope.

5.4 RESULTS

5.4.1. Excimer laser pattern ablation in cadaver eyes

(a) Smoothing of patterns produced by the laser

The bas-relief pattern produced on the cornea by shielding the underlying stroma by bent wire was best demonstrated by SEM (see figure 5.1a opposite). The smoothness of the ablated surface was comparable to Bowmans layer on the non-ablated ridges and the stromal architecture was obscured by a continuous membrane-like structure. The ridges, noted to have smooth perpendicular walls, were successfully ablated to produce a homogeneous, optically smooth surface (see figure 5.1b opposite). In some specimens the ablation to produce the pattern and the subsequent smoothing ablation were not coincident because of a slight shift of the Tudor Thomas stand. This resulted in a small peripheral annulus in which the ridges could still be seen (figures 5.1b opposite, 5.2b overpage).

The most suitable masking liquid was 1% HPMC since it was easy to apply and remove and filled the declivities between surface irregularities. HPMC fluoresced a bright blue when irradiated and corneal stroma a dark blue/black. There was thus a clear indication of the three dimensional geometry of stroma undergoing ablation. When 1% HPMC flooded the surface an even bright blue fluorescence was noted across the entire target area with each pulse. As the masking agent was ablated corneal stromal irregularities projected through the surface of the HPMC and were ablated, as dark blue, almost black, "islands" within the bright blue HPMC fluorescence. As ablation proceeded so the pattern and surrounding masking agent were removed until a common depth was reached at which point HPMC once again spread throughout the 3mm zone, indicated by homogeneous bright blue fluorescence. Further ablation beyond the original depth of 10-12 microns removed the little remaining HPMC and the entire area appeared dark blue/black with each pulse confirming that the pattern had been completely removed. If further pulses were applied then the 3mm zone of ablation was uniformly increased in depth (Fig 5.1b opposite). With relief patterns in excess of 30 microns it was more difficult to achieve uniform smoothness because of a meniscus effect where the masking agent met the vertical sides of the pillars of non-ablated tissue. It was found that blotting the edges with Weck-cell sponges reduced this effect.

Figure 5.1 Scanning electron micrographs of the surface of human donor corneas after excimer laser irradiation

- (a) The pattern created by shielding stroma with a piece of bent wire during irradiation is shown. The ablated surface adjacent to the non-ablated ridges (arrowed) is smooth and the ridges themselves are sharply demarcated. The sides of these ridges are perpendicular as is the edge of the ablated zone.

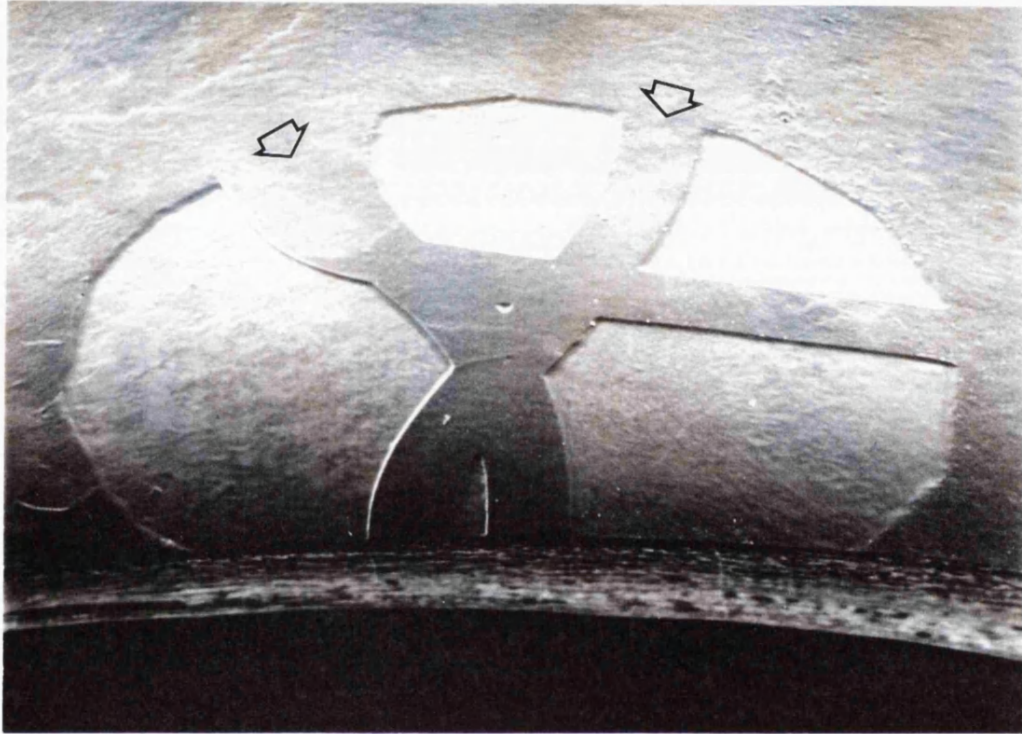

- (b) A pattern similar to that in (a) has now been ablated leaving an almost totally smooth surface. A small peripheral annulus indicates that there has been a slight shift in the position of the eye prior to the final smoothing ablation.

Figure 5.2 High power scanning electron micrographs of the ridges created and removed by excimer laser irradiation

(a) Shows the magnitude and edge quality of the ridge seen in figure 1

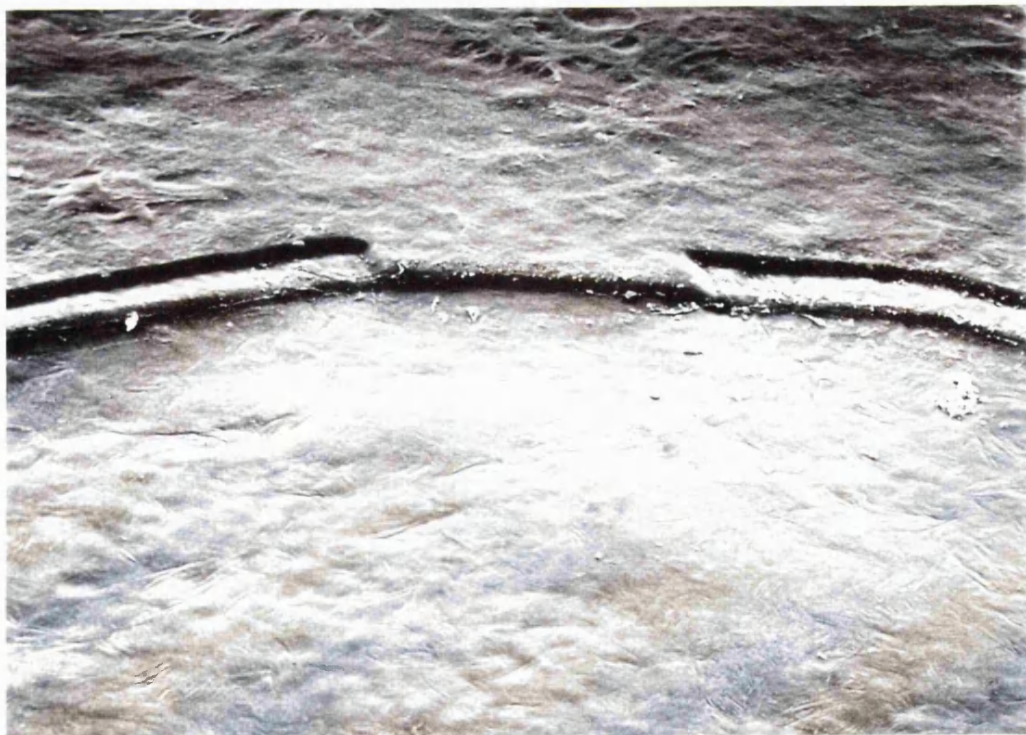
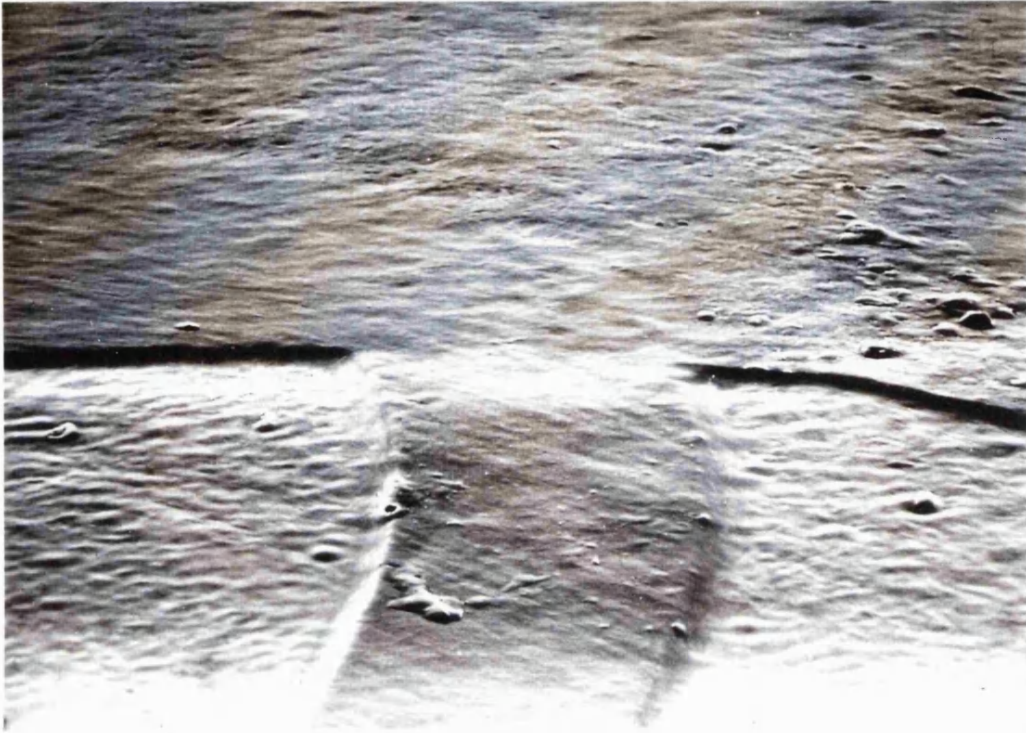

(b) Shows the residual portion of a ridge (fine arrows) after a smoothing procedure. The ablation depth involved in generating the initial pattern (closed arrow) and that involving its removal (open arrow) can be clearly distinguished as a result of displacement of the globe between the two procedures (Bar markers 100 microns)

(b) Removal of a cylindrical 'facet'

In this experiment a 1mm diameter cylinder of corneal stroma was ablated and filled with HPMC. On ablating the area around the cylinder there was differential fluorescence - the central spot (HPMC) fluoresced bright blue while the surrounding stroma, in contrast, appeared dark blue/black. The end-point was reached when the blue spot disappeared and the entire area of ablation became uniformly black, i.e. the surrounding stroma had been ablated to exactly the same depth as that of the original cylinder. The number of pulses required for these two processes was similar.

5.4.2 Excimer laser smoothing of surgical lamellar keratectomy beds

Scanning electron microscopy of the base and walls of a surgical lamellar keratectomy showed surfaces with a marked degree of destruction and dissociation of cellular and extracellular components (figure 5.3a opposite). The walls of such sites demonstrated stratification with alternate layers of compression and shearing. There was an annulus in which epithelial cells were wiped away from Bowman's layer because the surface tissue was displaced and compressed against and within the barrel of the trephine and debrided as the trephine rotated. The floor never displayed a smooth cleavage plane and always consisted of ripped, torn lamellae and displaced ruptured keratocytes (Fig 5.3a).

The most appropriate method of smoothing lamellar keratectomy beds was by frequent application of small amounts of masking agent with constant readjustment of the 'local distribution' of the liquid with Weck-cell (cellulose) sponges. This enabled removal of multiple small corneal surface perturbations without the unnecessary removal of deeper stroma. The resultant surface was smooth with some wrinkles and folds suggesting a surface membrane (Fig 5.3b opposite). Multiple overlapping ablation zones were used to smooth the entire lamellar keratectomy base (Fig 5.3c overpage). Zones already smoothed were masked with HPMC to avoid unnecessary ablation. This technique was important in establishing criteria for treating large areas of stroma in the subsequent clinical cases (chapter 6).

Figure 5.3 Scanning electron micrographs of the corneal surface subsequent to a) surgical lamellar keratectomy; b) and c) excimer laser irradiation.

(a) The bed of a lamellar keratectomy showing rough, disorganised and torn tissue

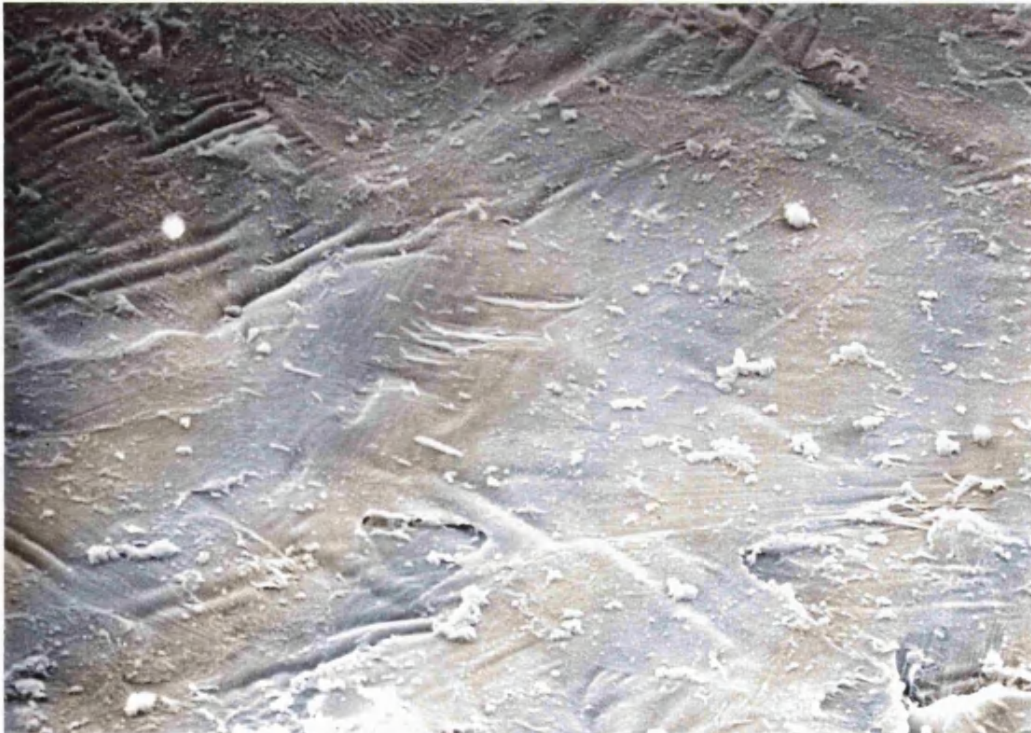

(b) A surgical lamellar keratectomy bed smoothed by excimer laser irradiation. The surface has a confluent membrane-like quality seen as wrinkles and folds produced during preparation for scanning electron microscopy

Figure 5.3 Scanning electron micrographs of the corneal surface subsequent to excimer irradiation
(ctd)

(c) A lamellar keratectomy bed smoothed by application of multiple overlapping zones of excimer laser radiation. The slight discontinuities between different zones are seen as variations in ablation depth and defined by arcuate boundaries (arrowed)



5.4 DISCUSSION

These laboratory studies suggested that the argon fluoride excimer laser could be used to smooth irregular corneal surfaces with a high degree of precision and with relative ease. It was hypothesised that where the aim was removal of a uniform, diffuse, superficial corneal opacity the precision of the techniques used above would be entirely suited to the task. Excimer laser ablation is a surface phenomenon and therefore irregular surfaces cannot be levelled as a single stage procedure by irradiation. If a rough surface of homogeneous tissue is irradiated then a uniform layer of tissue will be removed with each laser pulse (figure 5.4 opposite) and in order to produce a smooth surface a masking agent with a similar ablation rate to that of the target material must be used (figure 5.5 overpage). A liquid more easily ablated than the surrounding tissue would have to be constantly reapplied in order not to perpetuate surface perturbations deeper in the tissue. If the ablation rate were less than the surrounding tissue less frequent applications would be required and flow of the liquid between laser pulses would ensure that smoothing still occurred. The viscosity and the surface tension of the masking agent are also of importance. If liquids have high viscosity or surface tension they may form droplets and, on irradiation, contribute to further surface disturbances rather than smoothing. Surface tension and surface adhesion may also create problems in relation to filling deep surface excavations or those with low aspect ratios in terms of width to depth. The wetting agents selected are in clinical use and have a relatively prolonged contact with the corneal surface. All agents used were adequate for smoothing, but polyvinyl alcohol and 2% HPMC were too viscous and did not have good 'surface contour-following' properties. 1% HPMC however was found to have ideal viscosity and was also convenient to apply and remove.

In the laboratory investigations above it was possible only to produce models of uneven surfaces with uniform ablation rate. While these models are identical to some surfaces encountered clinically, e.g. during lamellar keratoplasty or following removal of pterygia, a special case is encountered where surface projections are formed by inclusions, e.g. calcium, with a lower ablation rate than that of intervening tissue troughs (figure 5.6 overpage). Surface smoothing in this case requires an adjustable "shield" through which the calcium peaks protrude and are ablated while the troughs are protected. The shield may then be lowered in order to complete the smoothing process. An ablation fluid with a slow ablation rate would be preferable for shielding. In practice although 1% HPMC may not be optimal it was certainly adequate as a shielding agent.

Figure 5.4 The effect of excimer laser radiation on an unmasked irregular surface.

- (a) The unexposed surface
- (b) After minimal exposure the surface irregularity is repeated deeper into the material, since a uniform layer of equal thickness is ablated across the entire exposed surface with each pulse.
- (c) The end result is a faithful representation of the original surface topography produced deep in the material.

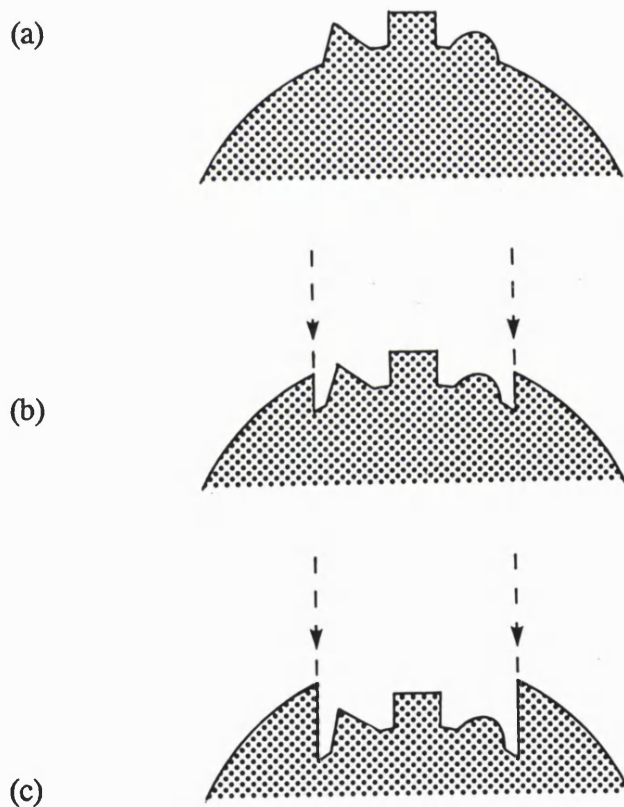

Figure 5.5 Production of a smooth surface by excimer laser radiation.

- (a) The irregular surface, analogous to a rough corneal surface, is covered with a masking liquid.
- (b) After initial exposure to excimer laser radiation both the masking liquid and surface projections have been partially ablated - the normal stroma between projections having been shielded from unnecessary ablation.
- (c) The resultant smooth surface at the end of the procedure (determination of the end-point is assisted by observation of a uniform fluorescence).

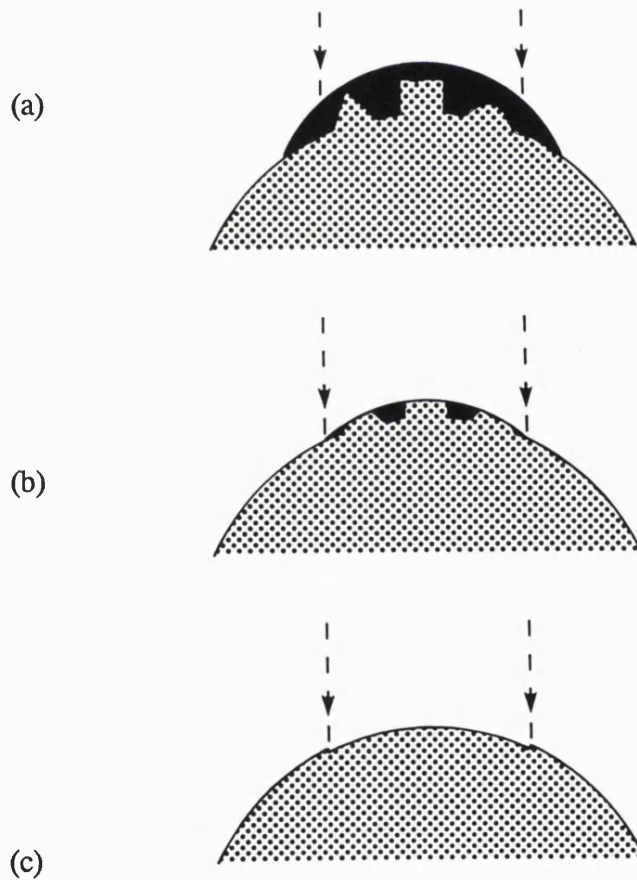
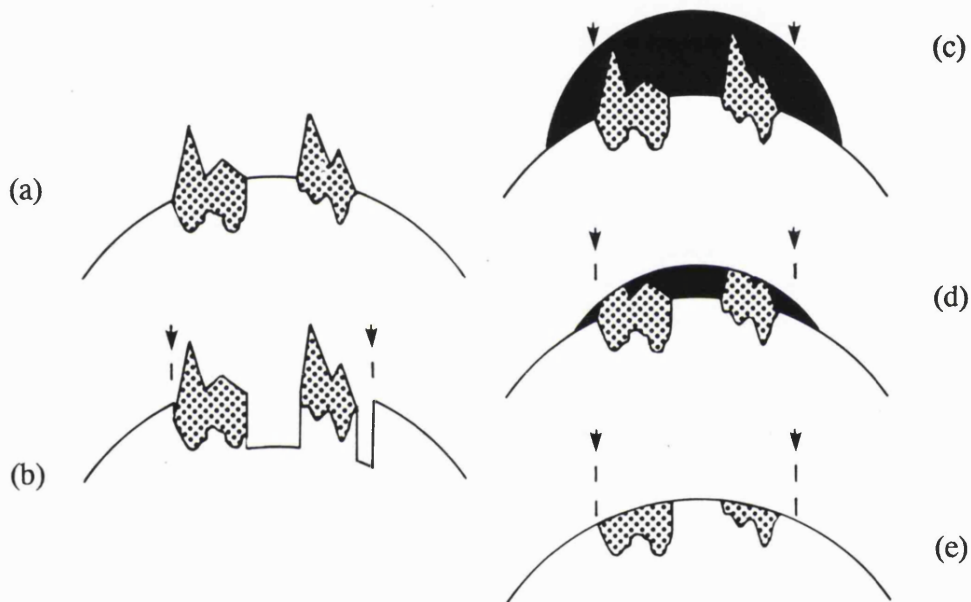

Figure 5.6 Ablation of dense calcium deposits embedded within the stroma and projecting from the surface.

- (a) Initial surface. Calcium deposits are shaded.
- (b) After excimer laser irradiation without masking. The calcium deposits, having a lower ablation rate per pulse, are barely altered from their original heights (dotted line) while the intervening exposed stroma which has a higher ablation rate, has been unnecessarily excavated (arrows).



- (c) The same surface shielded with a masking liquid.
- (d) During ablation only exposed peaks and masking liquid are removed.
- (e) At the end of the procedure the surface has been smoothed. To remove the remaining calcium deposits embedded in the stroma normal corneal stroma will, of necessity, have to be removed but its rate of removal can be regulated by further applications of masking liquid.

The control of the distribution of 1% HPMC during the ablation was an interactive process between manual application and removal. The closed tip size and curvature of Colibri forceps facilitated delivery of small quantities of HPMC without impairing the surgeon's view. Cellulose (Weck-cell) sponges applied to the edge of the target zone were used to remove excess liquid, however the fluid movement thus created by capillarity was found to be too rapid for accurate adjustment. It can be hypothesised that new sponge materials whose capillarity engenders less rapid fluid uptake would be more suited to the techniques described.

All three masking agents fluoresced when irradiated and the difference in the intensity and wavelength of fluorescence between the masking agent and the corneal substrate was helpful in monitoring the ablation process. The difference in fluorescence was best appreciated when viewing ablation of masked patterns of regular geometry. However, discrimination became more difficult during the ablation of masked, irregular, shallow surface perturbations. As a result of this target fluorescence longer wavelength photons are generated which have deeper penetration and potential for DNA damage (see chapter 3). The fluence associated with such secondary radiation at sites remote from the ablation surface however is low and as the fluorescence of the masking agent is primarily in the short wavelength, visible, portion of the electromagnetic spectrum, the predominant wavelengths produced are likely to be too long to be a secondary hazard of clinical significance (Sliney et al, 1991; Muller-Stolzenburg et al, 1990)..

The use of masking agents did not seem to affect the nature of the ablated surface since it was uniform in the pattern experiments (figure 5.1b, 5.2b). Although we did not undertake chemical analysis of the resultant surface after ablation, the homogeneity seen in our morphological studies indicates that no chemical interactions have occurred between the masking liquid and adjacent biological tissues. All surfaces were sealed with a "pseudomembrane" (Marshall et al, 1985; Marshall et al, 1986a and 1986b; Kerr Muir et al, 1987) as shown by wrinkling (Figure 5.3b), and previous studies have shown that whatever the nature of the pseudomembrane its existence is transitory and it does not interfere with subsequent healing processes Marshall et al, 1988).

5.5.1 Conclusion

The excimer laser can be used to remove tissue from the corneal surface with a high degree of precision leaving a smooth surface which is likely to be of good optical quality.

CHAPTER 6

PHOTOTHERAPEUTIC KERATECTOMY - ORIGINAL CLINICAL STUDIES

6.1 INTRODUCTION

6.1.1 Aims of the study

The aim of this study was to evaluate the safety and efficacy of excimer laser treatment (Phototherapeutic Keratectomy or PTK) of a series of patients with various forms of superficial corneal pathology.

6.2 METHODS AND STUDY DESIGN

A UV200 Excimer laser (Summit Technology, Waltham, Massachusetts, USA) with an emission wavelength of 193nm, a fixed pulse repetition rate of 10Hz and a fixed radiant exposure of 180mJ/cm² at the corneal plane was used. The system has been described in detail in section II (chapter 4, section II, page 69).

Our initial series comprised 25 patients who volunteered to undergo Excimer laser superficial keratectomy to remove band keratopathy or to smooth a roughened corneal surface arising from some other pathology (see tables II-VI). Guttæ amethocaine 1% was instilled, a speculum inserted and the patient taught to fixate the centre of a ring of fibre optic lights located around the laser aperture. A beam diameter was selected to match the areas to be treated and in some cases the size of the beam was reselected at different stages in the procedure. The effects of photoablation were assessed with the integral binocular operating microscope positioned alongside the laser aperture. Once steady fixation was achieved the masking liquid was applied to the corneal surface and photoablation commenced. During the process the surgeon could vary the site of ablation by making small movements of the patient's head (see figure 6.1 opposite). Following the procedure, which lasted about 15 minutes, a mydriatic (G.Homatropine 2%) and antibiotic (Oc.Chloramphenicol 1%) were instilled and the eye padded for 24 hours. Follow-up was daily for the first week, weekly for one month, three monthly for two further visits and then six monthly. For the first month G.Chloramphenicol 0.5% was used four times a day.

The corneal surface characteristics of selected patients were examined and recorded with a prototype photokeratoscope (Zabel et al, 1989). In addition, while it was impossible in the majority of cases to comment on the pre-operative status of the corneal endothelium due to superficial opacification it was examined post-operatively at intervals via specular reflection with the slit lamp. Refraction was carried out where possible.

Although the morphology of band keratopathy varies we subdivided the patients into two broad categories. The first had rough, craggy deposits with varying degrees of discomfort, the second smooth even deposits with little or no discomfort.

Two treatment regimes were undertaken. Either a single 4mm diameter zone or a series of partially overlapping 4mm diameter zones was ablated. The single area technique was most commonly used for smooth bands which caused impaired vision and glare and the

multiple zone technique for rough, painful bands. The noise associated with laser pulses (10Hz) was demonstrated to the patients prior to the procedure and they were warned to expect a faint smell of burning during treatment (vide infra).



Figure 6.1 Patient positioning and alignment

The 'patient' (Prof T Seiler, The Free University, Berlin) is positioned beneath the laser aperture. The surgeon (Mr M G Kerr Muir, St Thomas' Hospital, London) achieves exact alignment by ensuring that the helium-neon aiming beams intersect at a single point on the corneal surface (see fig 4.4 page 71). This alignment is much more critical when performing photorefractive keratectomy (PRK) - see later.

6.3 RESULTS

Details of the first 25 patients to undergo Excimer laser treatment of band keratopathy or superficial corneal pathology in the United Kingdom are given in tables II-VI opposite. Six cases are reported here in detail (page 114) and represent the spectrum of disease and illustrate different techniques of band removal possible with the Excimer laser.

Table II Rough band keratopathy treated by several overlapping ablation zones

No.	Sex	Age	Band type	Aetiology	Pre-op. Symptoms	VA (preop)	Post-op. symptoms	VA (postop)	Follow-up (mo)	Comment
1	F	49	rough surface, very irregular	increased serum Ca ⁺⁺	pain, photophobia, reduced VA	6/36	asymptomatic	6/12	30	band recurrence after 18 months
2	M	45	rough, very irregular	trauma	pain	PL	asymptomatic	PL	30	stable
3	M	50	rough, raised, thick band	trauma	pain	NPL	asymptomatic	NPL	30	stable
4	M	34	rough, irregular, disorganised ant. segment.	high myope, failed retinal detachment surgery	irritable, red, pain on blinking	PL	asymptomatic, pleased with cosmesis	PL	14	stable
5	F	66	central, proud, Ca ⁺⁺ plaque	HSV keratitis	pain, reduced VA	CF	asymptomatic, (occasional ache)	6/36	14	stable
6	F	72	classic band	Herpes zoster	pain, epiphora, reduced VA	6/24	asymptomatic	6/18	12	stable
7	F	33	islands of Ca ⁺⁺ (previous EDTA treatment)	uveitis in childhood	poor cosmesis, minimal discomfort	NPL	unchanged	NPL	10	highly mobile eye during treatment (surgery abandoned)
8	F	78	central Ca ⁺⁺ area and diffuse Ca ⁺⁺ surround	HSV keratitis	pain, epiphora, reduced VA	CF	asymptomatic, slight increase in VA	4/60	10	stable

Table III Rough band keratopathy treated with a single 'on axis' ablation zone

No.	Sex	Age	Band type	Aetiology	Pre-op. Symptoms	VA (preop)	Post-op. symptoms	VA (postop)	Follow-up (mo)	Comment
9	F	20	central Ca ⁺⁺ plaque	uveitis in childhood	poor cosmesis	NPL	improved cosmesis	NPL	10	epithelial ablation only required
10	F	80	rough, central, Ca ⁺⁺ deposit	interstitial keratitis	pain, epiphora	2/60	marked improvement	2/60	12	stable

Table IV Other disorders resulting in rough corneal surfaces treated by excimer ablation

No.	Sex	Age	Description	Pathology	Pre-op. Symptoms	VA (preop)	Post-op. symptoms	VA (postop)	Follow-up (mo)	Comment
11	M	27	Mucus plaque	atopic, vernal eye disease	pain, photophobia, reduced VA	6/60	asymptomatic	6/18	14	re-epithelialised, no plaque recurrence
12	F	45	rough, raised, granular dystrophy	recurrent granular dystrophy in a grafted (PK) eye	soreness, photophobia, reduced VA	6/24	asymptomatic	6/18	30	no recurrence
13	F	46	extensive lattice dystrophy	lattice dystrophy	glare, photophobia, reduced VA	6/60	asymptomatic, marked increase in VA	6/9	6	no recurrence, no glare hyperopic shift
14	F	46	central raised nodules	Salzmann's degeneration	discomfort, reduced VA	6/18	asymptomatic	6/12	10	stable
15	F	82	anterior stromal scarring	Cogan's epithelial dystrophy	reduced VA, recurrent erosion	4/60	asymptomatic, improved VA	6/12	10	stable, central area treated

Table V Smooth surface band keratopathy treated with multiple overlapping ablation zones

No.	Sex	Age	Band type	Aetiology	Pre-op. Symptoms	VA (preop)	Post-op. symptoms	VA (postop)	Follow-up (mo)	Comment
16	F	32	even, inferior cornea	trauma in childhood	discomfort	NPL	asymptomatic	NPL	30	stable but recurrence after 18/12 (slight)
17	M	67	even, dense, thick band	failed RD surgery, silicon oil in AC	glare, reduced VA poor cosmesis	HM	glare unchanged good cosmesis	CF	12	recurrence after 6/12
18	F	81	even, moderately dense	idiopathic	glare, reduced VA	6/18	reduced glare	6/18	12	change in refraction (hyperopic shift)
19	F	45	even	uveitis, glaucoma surgery	glare, reduced VA	6/9	glare greatly improved but reduced VA	6/18	12	change in refraction (hyperopic shift) and induced astigmatism
20	F	70	even, fine	idiopathic	reduced VA, Rx to improve view for cataract surgery	6/36	improved VA	6/12	10	cataract surgery facilitated

Table VI Smooth surface band keratopathy treated with 'on axis' single ablation zones

No.	Sex	Age	Band type	Aetiology	Pre-op. Symptoms	VA (preop)	Post-op. symptoms	VA (postop)	Follow-up (mo)	Comment
21	M	23	even, fine	uveitis	reduced VA	6/36	improved VA	6/9	30	cornea remains clear, refraction change (hyperopic shift)
22	M	84	even, fine	idiopathic	glare, reduced VA	6/24	glare improved and improved VA	6/12	14	refraction change, hyperopic shift)
23	F	73	even, fine	idiopathic	reduced VA	6/36	improved VA	6/18	14	change in refraction (hyperopic shift)
24	F	82	even, fine	idiopathic	glare, reduced VA	6/36	glare improved and improved VA	6/18	6	cornea remains clear
25	F	14	even, fine	idiopathic	glare, reduced VA	3/60	glare improved and improved VA	6/60	12	cornea remains clear

6.4 SELECTED CASE STUDIES

6.4.1 Group 1 Rough symptomatic (uncomfortable/painful) band keratopathy.

Case 1

A 49 year old female with systemic lupus erythematosus requiring renal dialysis since 1981 had a parathyroidectomy in 1984 for primary hyperparathyroidism. Her left eye had been painful since 1974 and the mainstay of her treatment was artificial tears. In 1987 she had removal of band keratopathy with the aid of a chelating agent, EDTA. In spite of this she still had severe pain in the left eye, aggravated by blinking, which disrupted sleep. There was extensive irregular, thickened band keratopathy with a visual acuity of 6/36. Islands of calcium protruded through unstable epithelium (figure 6.2a opposite). The right eye was normal.

In February 1988 she became the first sighted patient to undergo Excimer laser phototherapeutic keratectomy (PTK). She had multiple overlapping zones located in the central 6mm of the cornea (Fig 6.2b). Approximately 300-400 pulses were delivered to each site of ablation. The procedure was pain-free. One hour later however she complained of some discomfort which resolved over 36 hours when the cornea had re-epithelialised. One week later she was asymptomatic. At this stage the area of photoablation was smooth with minimal central thinning and a faint anterior stromal haze. The acuity was 6/24 improving to 6/12 with pinhole. At five months there was early recurrence of band keratopathy (figure 6.2c overpage). By 18 months it began to cause discomfort. A small central epithelial erosion and faint central stromal haze were noted at this time, with the zone of ablation remaining markedly clearer than the surrounding area (figure 6.2d).

Figure 6.2a-d Case 1. Rough band keratopathy

- (a) Pre-operative appearance. Extensive calcium deposition is present producing a grossly uneven surface.

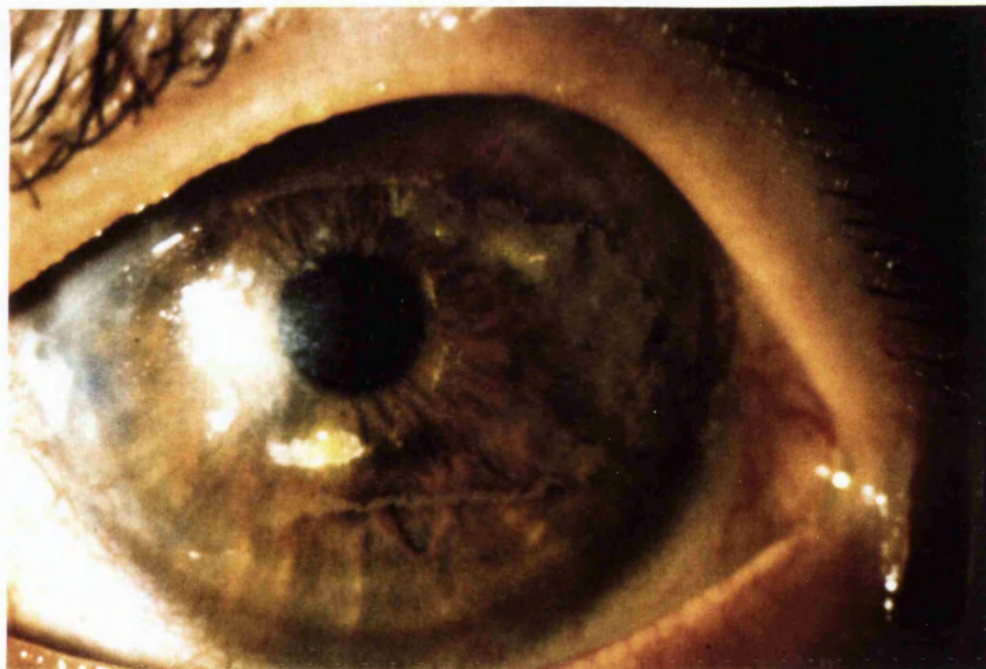
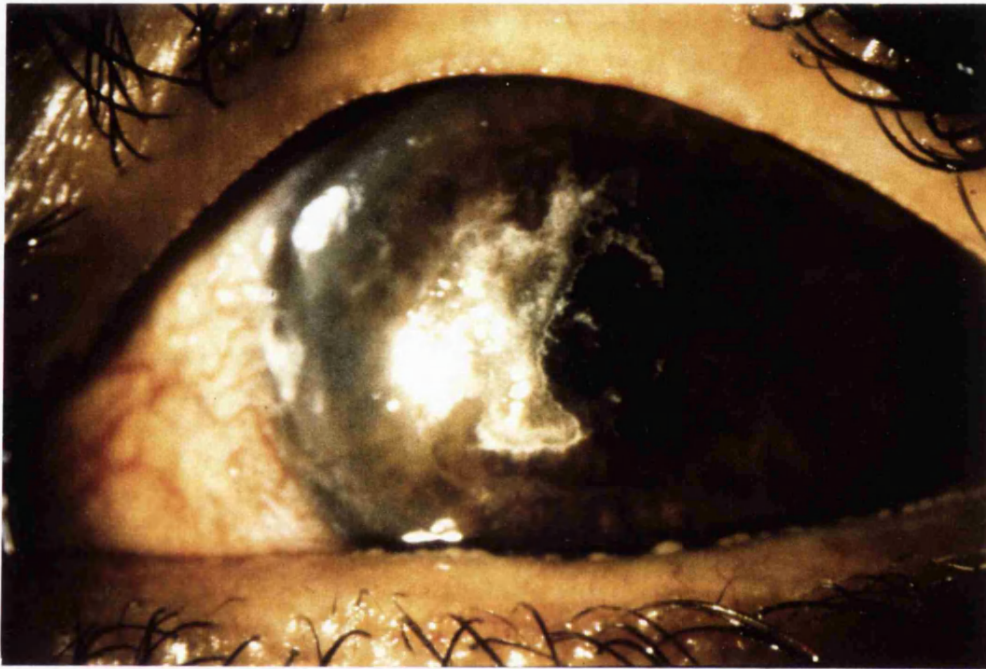

- (b) Immediate post-operative appearance. The majority of the calcium has been ablated leaving a smooth surface.

Figure 6.2 Case 1 (ctd)

(c) Appearance 5 months after treatment with the excimer laser.

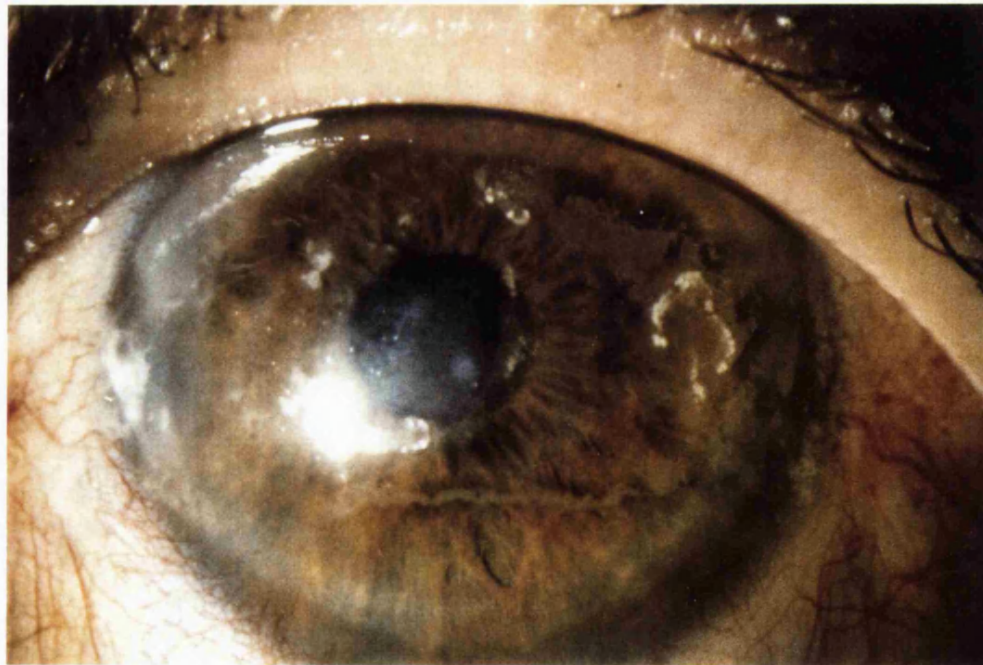
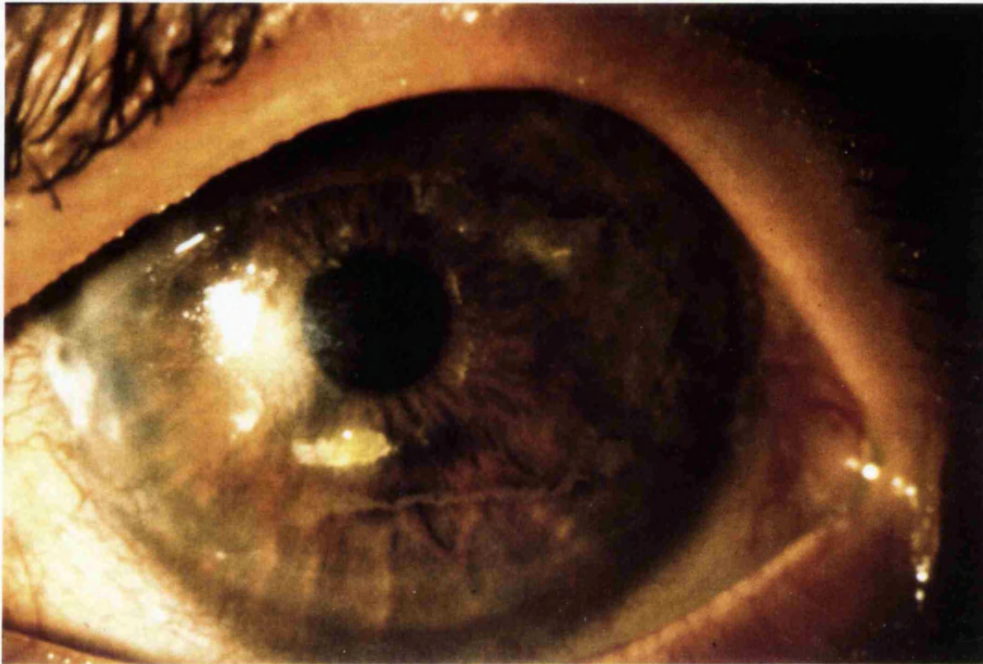

(d) Appearance 18 months after ablation. Treated areas remain clear, however recurrence of band keratopathy has resulted in some loss of corneal transparency.

Case 2

A 45 year old male had sustained blunt trauma to his left eye at the age of 24. Band keratopathy, cataract and glaucoma had resulted and he underwent a series of procedures between 1984 and 1987 which included a penetrating keratoplasty, cataract extraction with lens implant, two trabeculectomies and drainage tube insertion and revision. He had discomfort and the vision was perception of light with poor projection. There was a dense band keratopathy and a grossly roughened corneal surface with disrupted epithelium (figure 6.3a opposite). In August 1988 he underwent a PTK procedure. The large central calcium deposit was completely ablated using HPMC to mask the surrounding tissue.(Figure 6.3b opposite). After re-epithelialisation he has remained asymptomatic. 18 months later the central corneal zone was still clear and the more peripheral band remnants were unchanged.

Figure 6.3 Case 2. Rough band keratopathy.

- (a) Pre-operative appearance showing gross irregularity of the corneal surface and opacification. A large, central calcium plaque is evident.

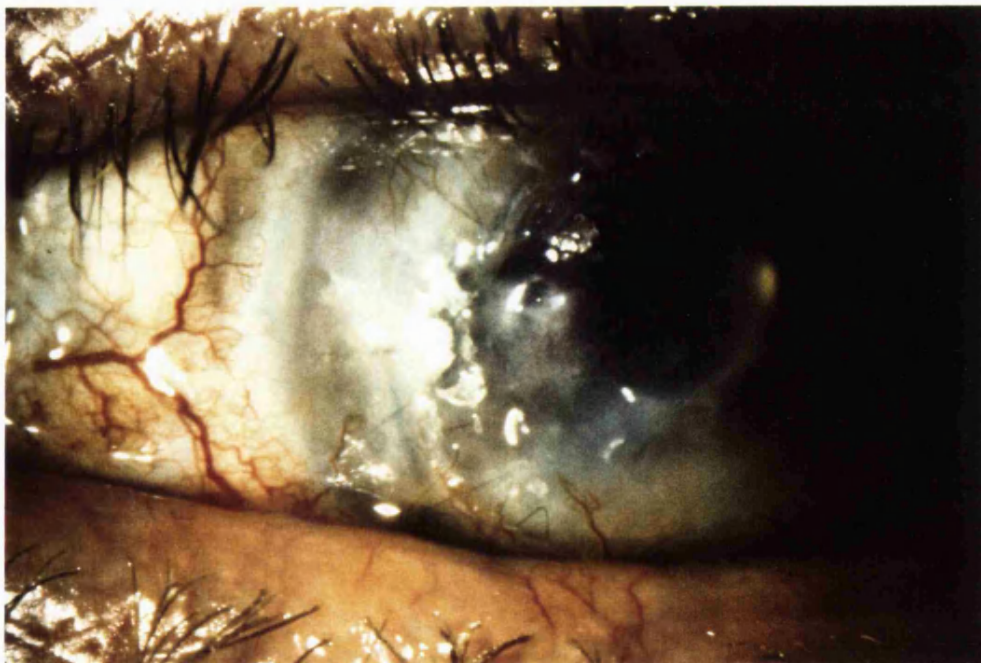

- (b) Post-operative appearance at one week. The large calcium deposit has been completely ablated. The patient remained asymptomatic after 18 months.

6.4.2 Group 2 Smooth (glare inducing) band keratopathy

Case 3

A 23 year old West Indian male had pulmonary sarcoidosis and bilateral panuveitis, the left eye being worse than the right. Acuities were 6/6 right, HM left. There was a fine, even band keratopathy across the lower 2/3rds of the left cornea with early peripheral changes in the right eye. In June 1988 he had left PTK procedure with a 3mm diameter beam centred on the visual axis. Approximately 200 pulses were delivered of which 150 were required to remove the epithelium. Re-epithelialisation was complete within 48 hours. One year later the visual acuity had improved to 6/12, although no conclusions can be drawn from this improvement since the panuveitis had responded to treatment (figure 6.4 opposite).

Figure 6.4 Case 3. Even, diffuse band keratopathy.

Appearance 1 year following excimer laser ablation of a single, "on-axis" zone. The photograph was taken slightly eccentrically in order to highlight the enhanced transparency of the ablated zone against the iris.

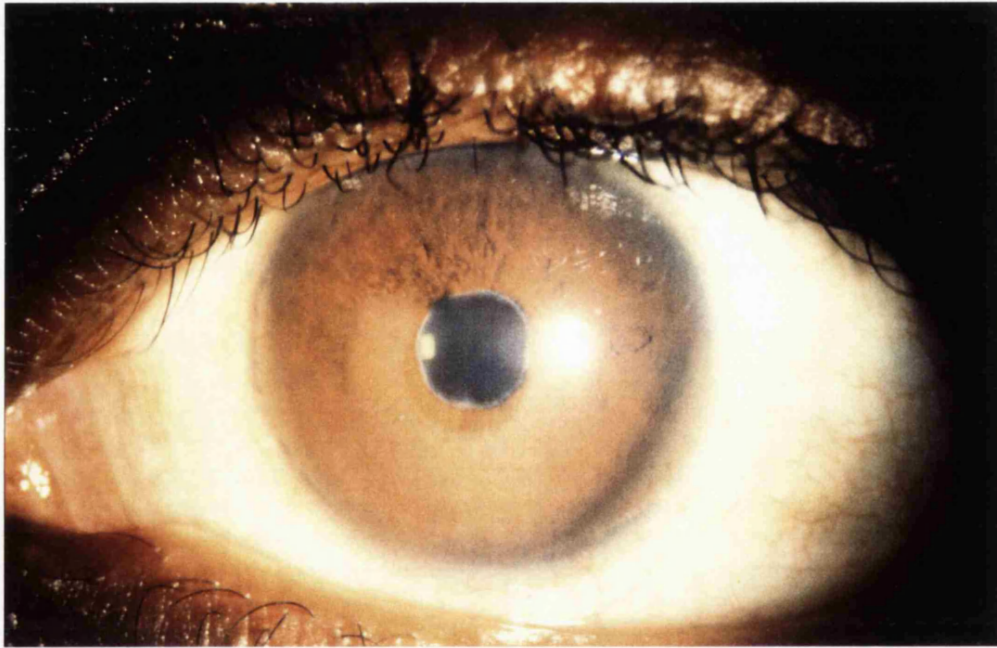

Case 4

A 72 year old male had bilateral evenly distributed idiopathic band keratopathy (Figure 6.5a opposite). He had no discomfort but complained of glare and impaired vision: 6/24 right and 6/18 left. He had a right 4mm axial PTK without 1% HPMC masking and the appearance at 3 months is seen in figures 6.5b (opposite), and 6.5c and 6.5d overpage. Figure 6.5c, using sclerotic scatter, highlights the clarity of the central cornea compared to the adjacent band keratopathy against the background of the dilated pupil. Visual acuity in the right eye improved to 6/12 but veiling glare was subjectively unchanged.

Figure 6.5 Case 4. Even, diffuse band keratopathy.

- (a) Pre-operative appearance showing an even, diffuse band keratopathy - granular in places.

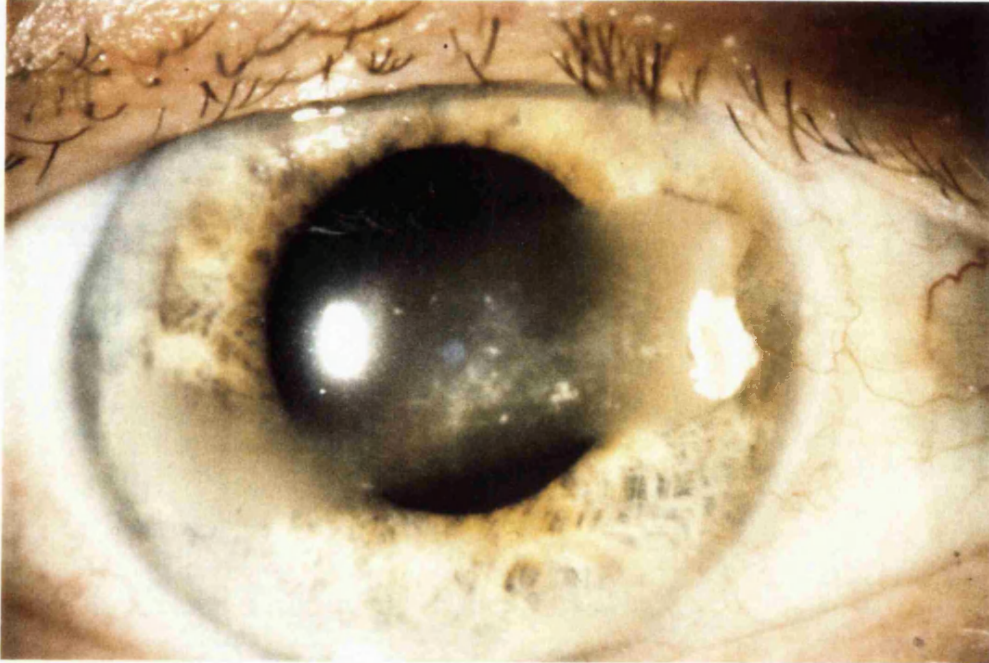

- (b) The appearance 3 months after excimer ablation of a single, central "on-axis" zone to clear the visual axis. The increased clarity of the central ablated zone is evident and the slight central haze represents lenticular opacity.

Figure 6.5 Case 4. Even, diffuse band keratopathy.
(ctd)

- (c) Post-operative appearance at 3 months utilising sclerotic scatter to highlight the clarity of the treated area. Note the remarkable clarity of this central zone (underlying lenticular opacities now being excluded).

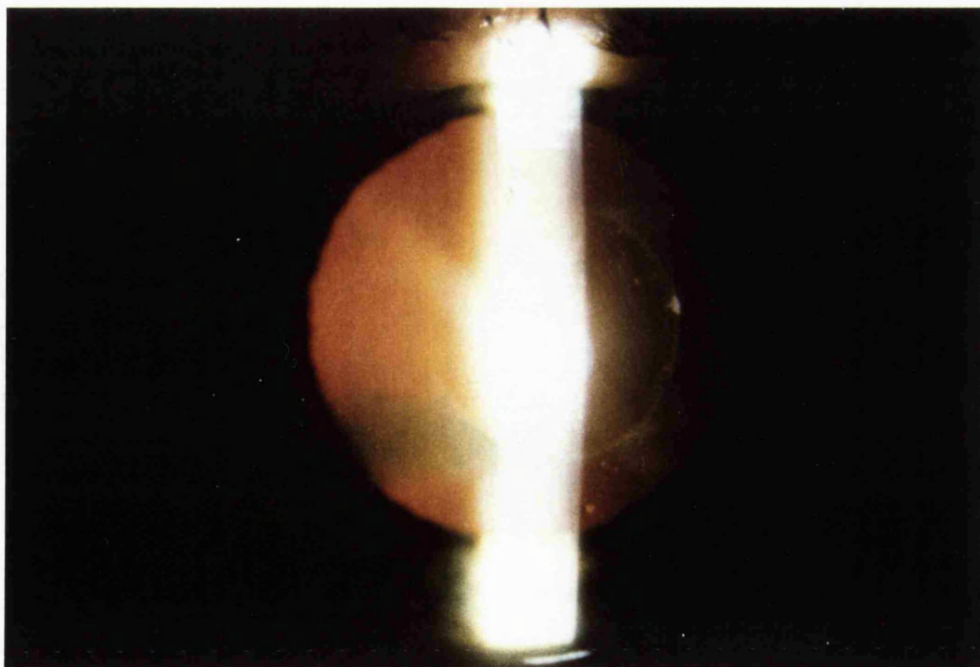
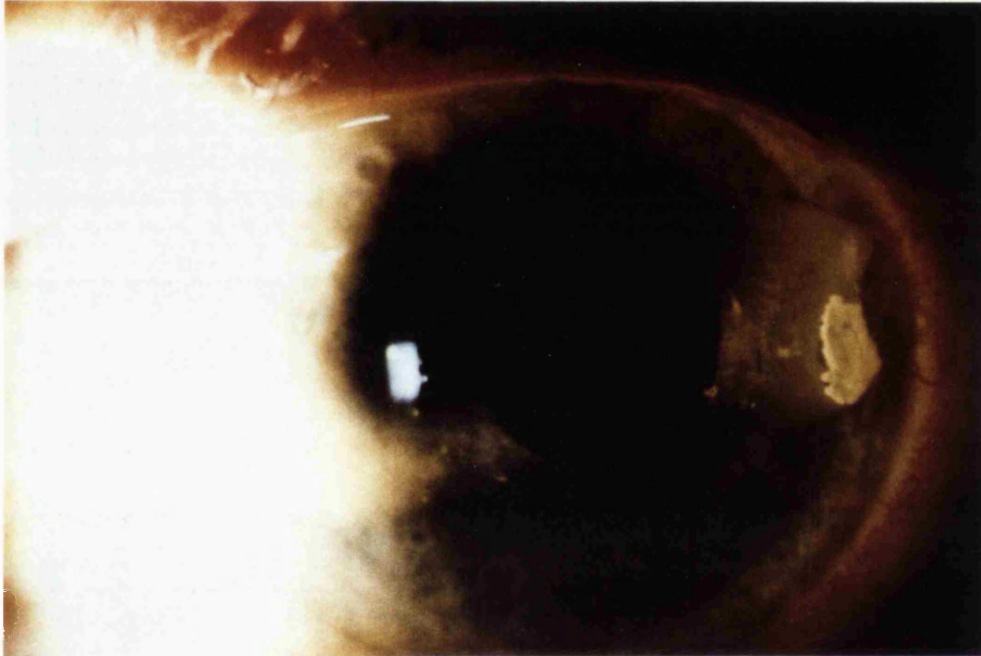

- (d) Appearance 4 months after ablation by retro-illumination which confirms the enhanced transparency of the central cornea.

Case 5

A 32 year old Jamaican female had been blind in the right eye (NPL) from childhood. The cause was unknown. The eye was very uncomfortable. The left eye was normal. There was a moderately dense band keratopathy across the inferior two thirds of the right cornea and discrete white deep stromal deposits in the same area (figure 6.6a opposite). There was seclusio pupillae and a dense cataract. Phototherapeutic keratectomy (PTK) was carried out with five 3mm diameter, partially overlapping, zones (Figure 6.6b). Within 48 hours she was asymptomatic with an intact epithelium. One year following treatment she had occasional mild photophobia. There was a faint anterior stromal haze in areas of ablation, with evidence of recurrence of band keratopathy in the centre of these zones with a further peripheral deposition causing irregular boundaries (figure 6.6c overpage).

Figure 6.6 Case 5. Even, diffuse band keratopathy.

- (a) Pre-operative appearance showing an even band keratopathy distributed over the inferior cornea. Deep, white stromal deposits and a dense cataract can also be seen.

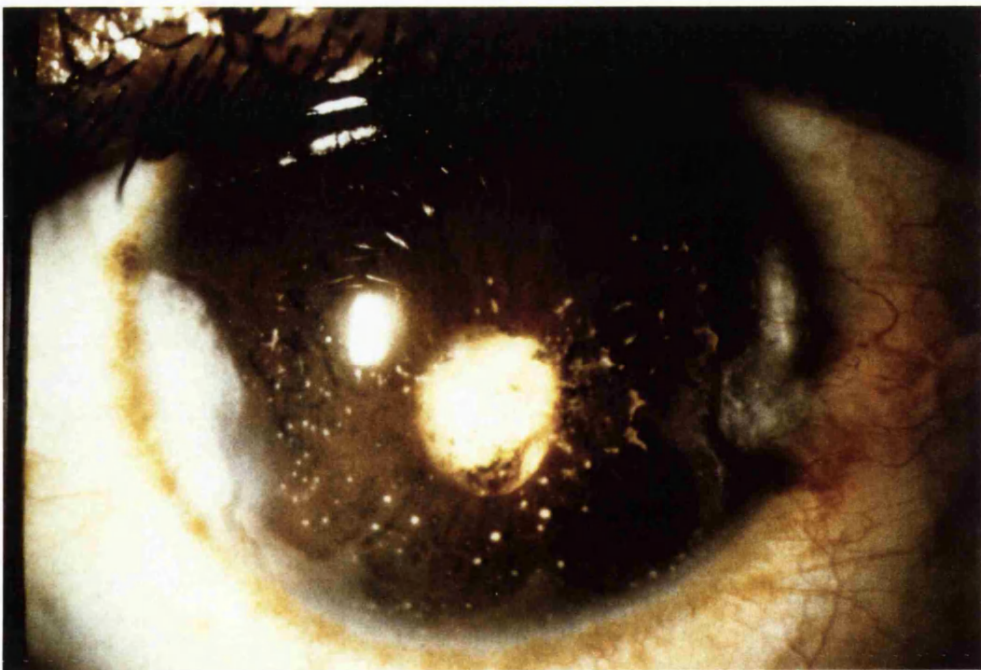
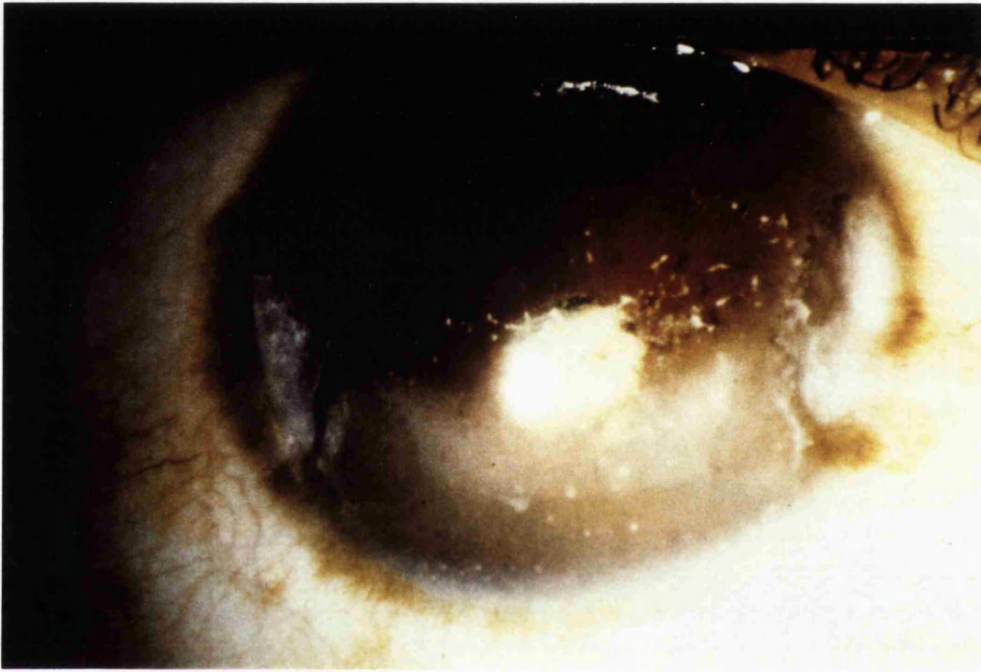

- (b) Post-operative appearance at 48 hours. The overlapping zones of ablation are clearly seen. Re-epithelialisation was complete at this stage.

Figure 6.6 Case 5. Even, diffuse band keratopathy.

(ctd)

(c) Appearance at one year. Although the ablation zones are still clearly seen there are signs of calcium deposition along the margins of some of the ablation sites and in the centre of 2 of these zones. The patient was still asymptomatic.

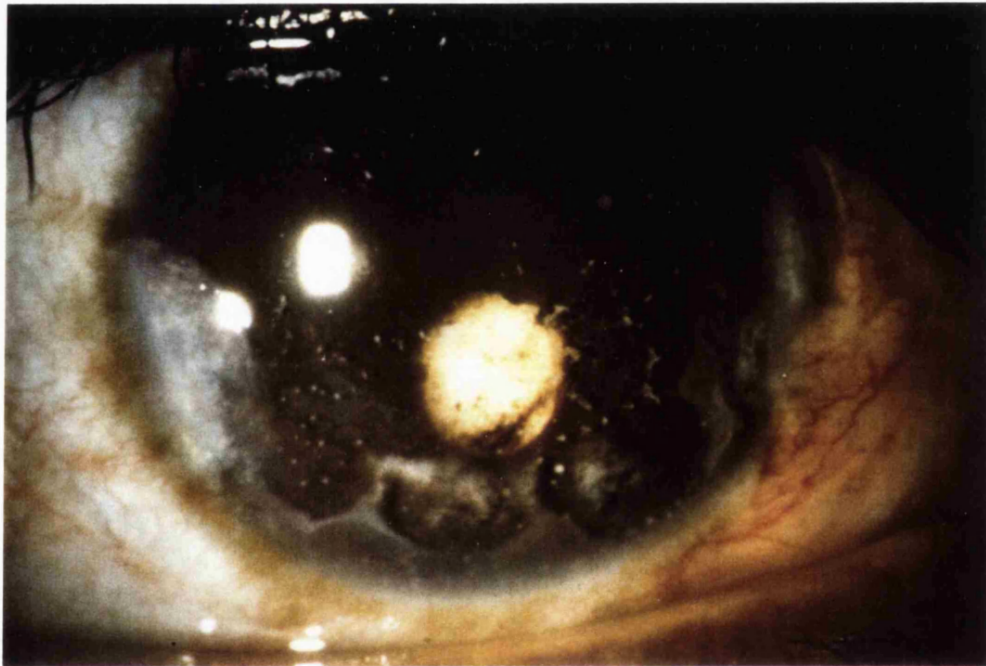

Case 6

A 67 year old male developed a dense evenly distributed band keratopathy in his right eye after retinal detachment surgery which had included injection of silicone oil (figure 6.7a opposite). He had also undergone extracapsular cataract extraction with insertion of a posterior chamber intraocular lens. Before phototherapeutic keratectomy there was only a limited view into the anterior chamber in which silicone oil was present. Vision was hand movements in the inferior field only. PTK was undertaken primarily for cosmetic reasons and to improve the view of the posterior segment. Overlapping ablation zones were used to clear the cornea of band. 1% HPMC was used to mask previously ablated areas. At 3 months the cornea was clear with an optically smooth surface (figure 6.7b). A good view of the anterior chamber, intraocular lens and retina was obtained. As expected there was no significant improvement in vision.

Figure 6.7 Case 6. Dense, even band keratopathy treated with overlapping ablation zones in order to clear the entire corneal surface.

- (a) Pre-operative appearance. A dense, even band keratopathy extends across most of the cornea. Silicone oil was present in the anterior chamber, shown by the reflex which delineates its margin underlying the 10/0 nylon sutures from previous cataract surgery.

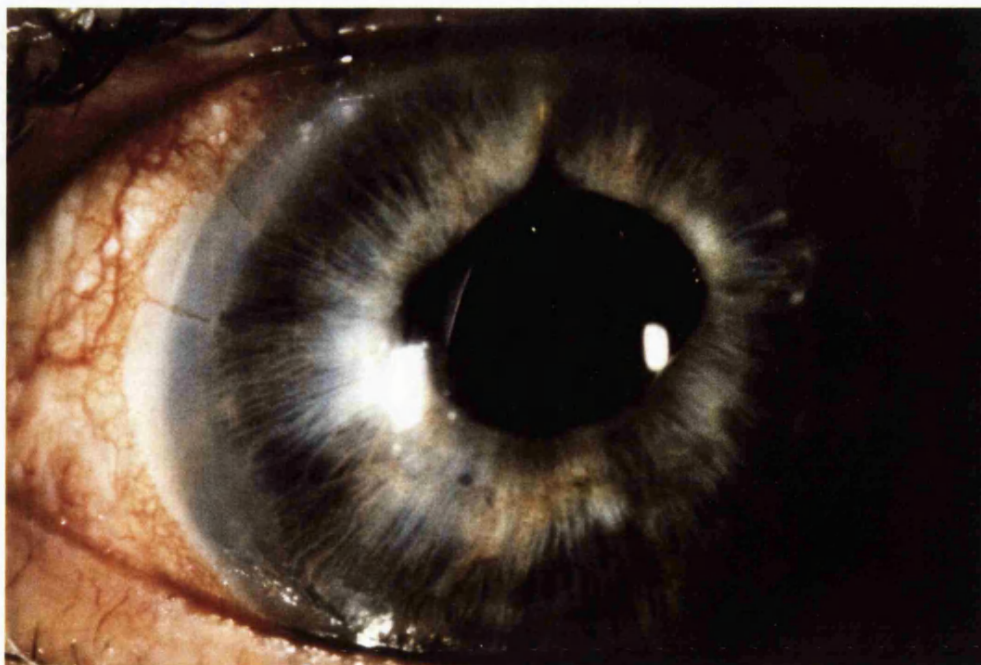
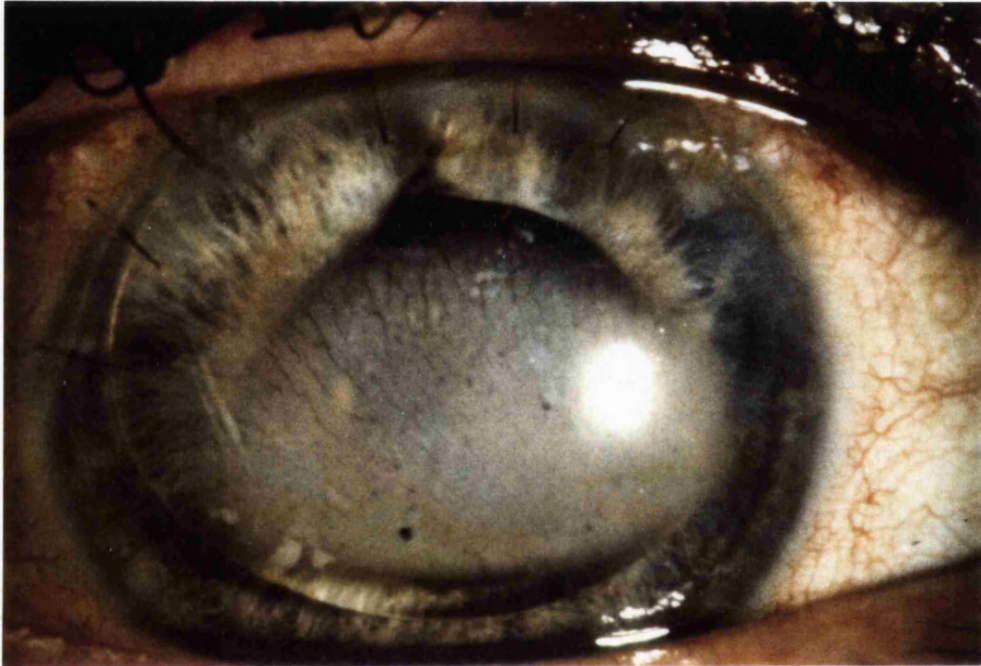

- (b) Appearance 3 months following excimer laser ablation utilising overlapping and contiguous zones. There has been total clearance of the calcium leaving a smooth, clear cornea. Slight residual haze represents deep, pre-existing, stromal scarring.

6.5 GENERAL COMMENTS

No patients reported discomfort during the procedure. Post-operatively the majority of patients experienced some discomfort for 24 - 48 hours. The intensity and duration of discomfort was related to the area of ablation. Oral analgesics were required for 24 hours in all patients but in all cases re-epithelialisation was complete by 48 hours.

16 of the 25 patients had an improvement in visual acuity (Tables II-VI). The 13 patients with uneven, symptomatic (painful) band keratopathy were greatly improved and 5 became symptom free.

Improvement in visual acuity occurred in those patients who had an even band keratopathy which responded well to photoablation with minimal or no masking. In the 7 patients troubled by glare (typically eyes with good visual potential and an evenly distributed "ground glass" band keratopathy) all were markedly improved post-operatively. Three patients in the series were pleased with the improved appearance of their eyes.

In most of the cases treated it was impossible to assess the central endothelium pre-operatively due to the overlying band keratopathy. Examination by slit lamp specular microscopy was carried out post-operatively at various stages of the follow-up and none of the patients was found to have any endothelial disturbance.

6.6 DISCUSSION

6.6.1 General

Our studies have not identified any complications or undesirable findings that would preclude further investigation of the clinical use of excimer lasers in ophthalmic surgical practice. Although preoperative visual acuity was poor in a large proportion of patients, all except four were able to fixate with the eye undergoing treatment. In these four patients adequate alignment was achieved with the normal eye fixating an adjustable target at one side of the laser aperture. In only one patient (case 7) was it impossible to treat the band keratopathy because of eye movement. None of these patients detected the induced fluorescence during ablation in spite of this being clearly visible to all observers. In a further group of patients undergoing photorefractive keratectomy some were aware of a faint blue haze with each pulse. In contrast to the lack of visual stimulation auditory

and olfactory sensations were notable. The patients were warned about the noise and the smell of burning and both were demonstrated prior to the procedure by ablating paper. (The smell is a little disconcerting to some patients as it is rather like that of singed hair!). The biophysical mechanism of the smell is difficult to explain. Current concepts of ablation consider that tissue removal occurs due to a photochemical process of bond breaking rather than a thermal event. Some workers originally considered the process to be an ultrafast thermal event with tissue loss due to massive vibrational modes breaking macromolecular bonds (Andrew et al, 1983). These thermal events could have resulted in "burn-like" smells. Since the molecular fragmentation depends on wavelength most workers now consider that ablation is a photochemical process with residual energy used to eject fragments from the surface (Garrison and Srinivasan, 1985). Smells must be related to airborne particles and the similarity of smell of Excimer ablated and thermally damaged biological tissue implies that similar types of particles are generated by both of these processes.

Tables II to VI, show that postoperative progress was related to the extent of the initial pathology. Systematic analysis of the patient subsets was difficult because there were, by definition, significant variations in pathology. However, all patients with rough band keratopathy who had experienced pain preoperatively became asymptomatic (Tables II and III). Most were treated with several overlapping ablation zones in order to smooth the cornea completely (Table II). Table III however includes those patients who had a relatively small rough central area of band which was successfully treated with a single central ablation. In four patients visual acuity improved. Those with no improvement had extensive pathology of which the band formed only one part.

Four of the five patients with allied disorders which resulted in a rough corneal surface showed an improvement in visual acuity. Those with symptoms of soreness pain and photophobia were rendered asymptomatic (Table IV).

Smooth surfaced band deposition was treated with either several overlapping ablation zones (Table V) or a single "on-axis" ablation zone, 4mm in diameter (Table VI). The principal symptoms were reduced visual acuity and glare. Those patients with glare had a marked improvement which was sustained throughout the follow-up period (6 to 30 months). In the group treated with overlapping zones one patient showed an increase in visual acuity, one a reduced visual acuity and the other three no significant difference.

In case 19 glare was markedly improved but acuity decreased. This reduction was due to irregular astigmatism because of the faceted surface generated by overlapping ablation zones. In contrast, in the group in which a central "on-axis" zone was ablated (Table VI) visual acuity was improved in each case and glare reduced.

6.6.2 The 'hyperopic shift'

Where refraction results could be obtained a "plus shift", i.e. towards hypermetropia, was noted. Those patients in whom accurate subjective refraction was possible are listed in table VII below. The mean hyperopic shift for this group was 2.85 dioptres.

Table VII Refraction results before and after ablation (where applicable)

No.	Pre-op VA	Pre-op refraction	Post-op VA	Post-op refraction
18	6/18	+3.00DS	6/18	+5.50DS
19	6/9	plano	6/18	+4.00DS/-2.50DC x 85
21	6/36	plano	6/9	+1.50DS
22	6/24	+1.00DS	6/12	+4.50DS
23	6/36	+0.50DS	6/18	+5.00DS/-1.75DC x 35

This hyperopic shift (which is equivalent to a myopic correction) was an unexpected finding as the smoothing procedure is not analogous to photorefractive keratectomy (PRK) in which a deliberate attempt is made to reprofile the anterior corneal surface in order to effect a change in refraction (see section IV). This flattening of the cornea implies that some form of differential ablation must have occurred (Marshall, 1986; Munnerlyn et al, 1988; Seiler et al, 1990; McDonald et al, 1990; Taylor et al, 1989). There are several potential mechanisms that could account for this. First, if the band progressively thinned towards the visual axis then constant irradiance from the laser would effect greater ablation centrally and induce a hyperopic shift. This effect would be enhanced if the ablation rate of the band was less than stroma. Secondly, although excimer laser radiation will remove an even layer of tissue regardless of the curvature of the surface, the subsurface structure of the cornea is laminated. Removal of central portions of corneal lamellae could conceivably cause centrifugal differential contraction and central flattening.

Thirdly, the centrifugal spray of particles of debris and ablation products might be expected to shield the stroma and could, theoretically, provide progressively greater shielding towards the edge of the ablated zone. Fourthly, the increased obliquity of incident radiation falling upon more peripheral cornea might result in a relative decrease in energy density as the edge of the ablation zone is approached. It is unlikely, however, that the degree of differential ablation encountered could arise from inhomogeneities in the excimer beam. Fifthly, the maximum diameter of the ablation zone used in this study was limited to only 4mm, in part due to the conservative approach that we adopted in these early cases (larger ablation zones would, by definition, remove a greater volume of corneal tissue) and partly due to technical constraints. It is possible that a relative surface flattening could have occurred if the new corneal epithelium thinned towards the centre of the treated area. Conversely, the new epithelium could conceivably have become slightly 'heaped up' or hyperplastic at the edge of the ablation zone due to the relatively sharp change in contour which occurred in this region. This would have the same relative effect as central epithelial thinning. We hypothesise therefore that the hyperopic shift may be considerably reduced if larger diameter ablation zones are used.

6.7 CONCLUSIONS AND PATIENT SELECTION GUIDELINES FOR PTK

From this study, which was the first series of patients with corneal pathology treated with an excimer laser worldwide, it is possible to put forward recommendations for patient selection. Firstly, for patients with rough band keratopathy the excimer laser is a successful treatment. All patients with pain and photophobia became asymptomatic (these eyes will usually have limited visual potential). Secondly, where the pathology is limited to the anterior stroma pain relief is likely to be accompanied by an improvement in visual acuity. Thirdly, in eyes with good visual potential it is best not to clear all of the band keratopathy by using overlapping ablation zones since, although glare will be markedly reduced, irregular astigmatism may result which could lead to reduced visual acuity. Thus, a single, axial zone of ablation should be employed. We have also demonstrated that a hyperopic shift occurs when the central cornea is ablated and patients should be warned about the possibility of anisometropia. In conclusion, given the encouraging results, the ease with which the procedure can be performed, the patient acceptance of the procedure, and the fact that all cases were treated on an out-patient basis, excimer laser phototherapeutic keratectomy (PTK) would seem to be an excellent alternative treatment modality for these cases.

SECTION IV

THE DEVELOPMENT OF PHOTOREFRACTIVE KERATECTOMY (PRK)

CHAPTER 7

PHOTOREFRACTIVE KERATECTOMY - ORIGINAL CLINICAL STUDIES

7.1 INTRODUCTION

7.1.1 Aims of the study

The first United Kingdom study to evaluate myopic photorefractive keratectomy (PRK) procedures commenced at St Thomas' Hospital, London in November 1989 (Gartry et al, 1991b; Gartry et al, 1992a. The aim of this study was to investigate the safety and efficacy of photorefractive keratectomy as well as the predictability and stability of the induced refractive change.

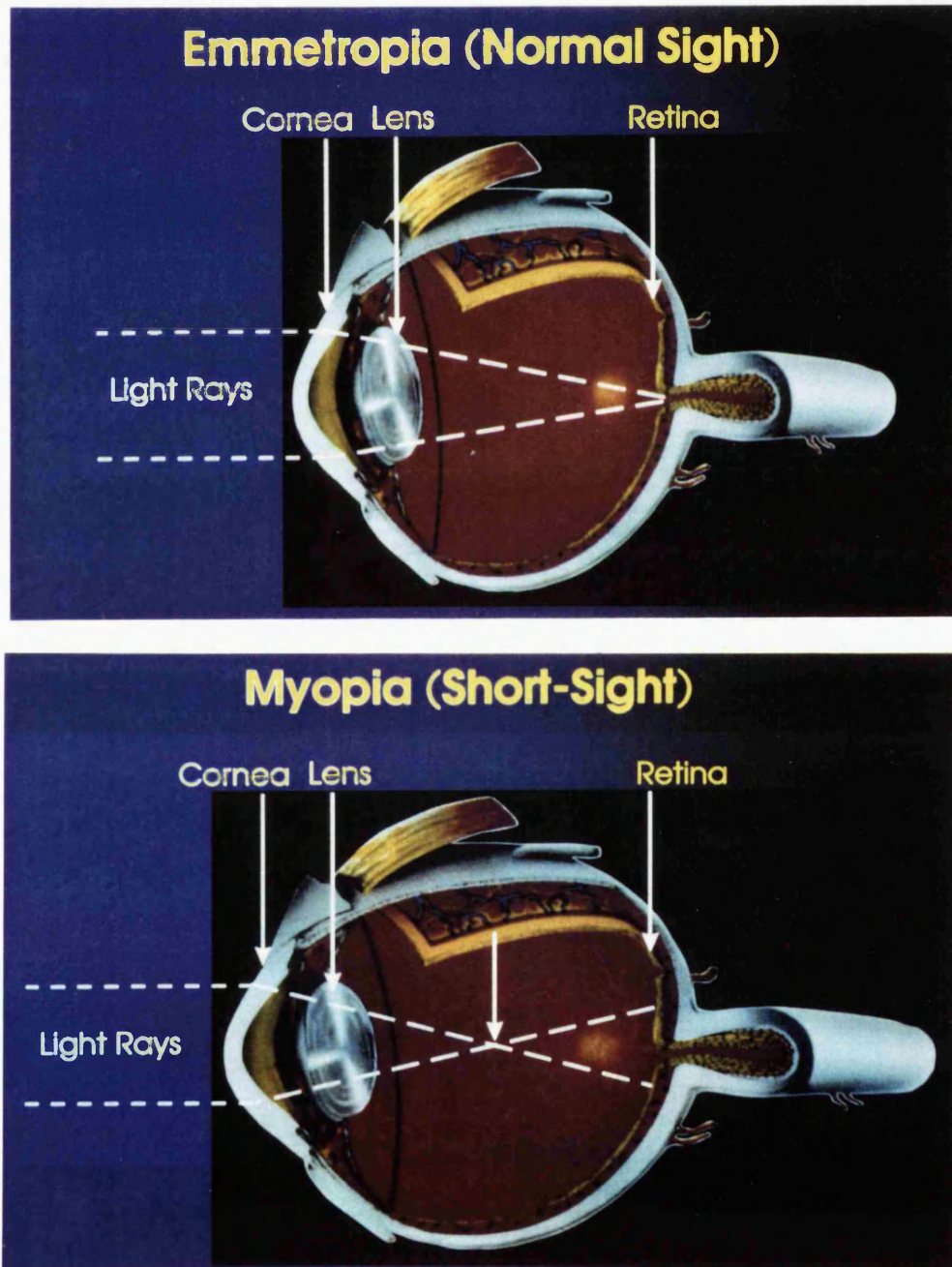

Figure 7.1 Ray diagram illustrating the focusing of light rays from a distant object to a point in front of the retina in the myopic eye

7.1.2 Myopia - the scale of the problem

While myopia or short-sight is not an ocular disease as such (except in the rare cases of pathological, progressive high myopia), nevertheless it has been correctly described as the commonest ocular abnormality requiring treatment. Depending upon definition, around 20% of the UK and USA populations are myopic (Tassman, 1932; Sorsby et al, 1960; Sperduto et al, 1983) a figure which rises to around 40% in some parts of Japan and China.

In the United Kingdom therefore around 8 to 10 million people suffer the inconvenience of myopia. In this refractive error rays of light from a distant object entering the eye are brought to a focus in front of the retina (see figure 7.1 opposite). This may be due to a relatively long eyeball, a cornea which is too steeply curved or a combination of these two factors. Even a relatively small amount of myopia results in distant objects being blurred significantly. For example, minus one dioptre (-1.00D) of myopia would result in a Snellen unaided vision of between 6/12 (20/40) and 6/18 (20/60), which is below the accepted driving test standard of approximately 6/10 (20/33). This is equivalent to the recognition of number plate letters 79.4mm high at a distance of 20.5 metres (DVLA Standards, 1993). Spectacles or contact lenses form the mainstay of treatment but can be a hindrance in various occupations and sports. In addition, because of edge thickness, high minus lenses are unsightly and image quality is reduced by minification and optical aberrations. A large number of myopes would be grateful therefore to be free from such optical aids.

7.1.3 Excimer laser photorefractive keratectomy for myopia (PRK)

As discussed in chapter 3, the excimer laser has a unique mechanism of action which allows the surgeon to remove layers of tissue from the corneal surface with an exceptionally high degree of precision. Following the initial suggestion (Trokel et al, 1983) that these lasers might be used for corneal surgery, extensive laboratory studies were conducted in the US and the UK (Marshall et al, 1985; Marshall et al, 1988; Gartry et al, 1991a; McDonald et al, 1991) and in February 1988 the first patient (worldwide) of a prospective series of sighted patients with corneal pathology was treated with the excimer laser at St Thomas' Hospital, London (Gartry et al, 1991a).

7.2 HUMAN PRK TRIALS - METHODS AND STUDY DESIGN

7.2.1 The Laser

A UV200 Excimer excimer laser (Summit Technology, Waltham, Massachusetts, USA) with an emission wavelength of 193nm, a fixed pulse repetition rate of 10Hz and a fixed radiant exposure of 180mJ/cm² at the cornea was used. The system has been described in detail in chapter 4, section II, page 69. Early laboratory studies indicated that, at this energy level, approximately 0.22 microns of corneal tissue was removed with each pulse. Since corneal reprofiling (PRK) is achieved by cutting a step function into the corneal surface with successive pulses of laser energy passing through a progressively expanding iris diaphragm (figure 7.2 opposite), this averaged value for the amount of tissue removed per pulse, or **ablation rate**, is required for the software algorithm within the laser. The standard 'Munnerlyn algorithm' was used throughout (Munnerlyn et al, 1988) (see section II, chapter 4, page 77) and, to facilitate comparison between patients, the standard ablation rate of 0.22 microns per pulse was programmed in all procedures (although lasers manufactured more recently have incorporated a fixed value of 0.25 microns/pulse in the algorithm). In addition, a standard ablation zone diameter of 4mm (the maximum available at the commencement of the study) was selected in each case. There was no effluent removal system and no eye stabilising system. The patient was required to fixate a target light within the laser aperture for the duration of the procedure (see figure 7.3b) which was, on average, 14 seconds.

7.2.2 Human Studies

Following two years experience in the treatment of corneal pathology using the excimer laser (Gartry et al, 1991a), Ethics Committee approval was granted for an investigation of photorefractive keratectomy (PRK) in humans. The study was in two phases :

- (A) In blind eyes to assess the safety of the procedure and consolidate the surgical technique and (given satisfactory results).....
- (B) In sighted eyes to determine predictability and stability of induced refractive change.

Figure 7.2 Photorefractive keratectomy (PRK) - reprofiling the corneal surface

The ring patterns etched into the corneal surface immediately after -7.00D treatments. The peripheral rings have straight edges as a consequence of the overlapping leaves of the iris diaphragm (open arrows). The pattern gives information about the steadiness of fixation and the centration of the treatment zone. The irregular light reflex beyond the area of ablation is the edge of the debrided central epithelial zone (closed arrows).

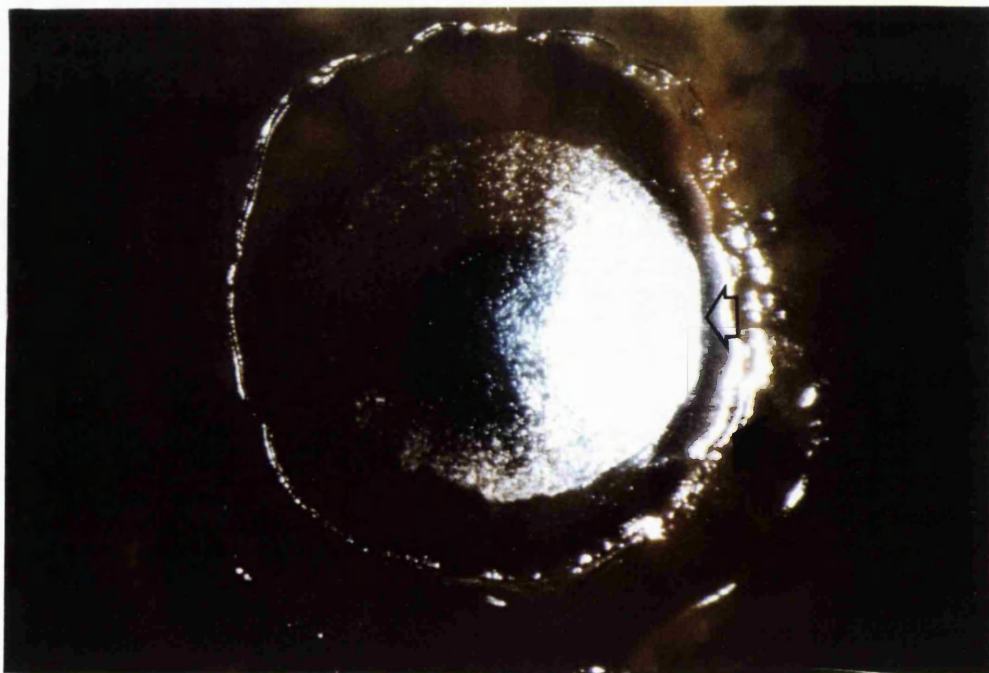
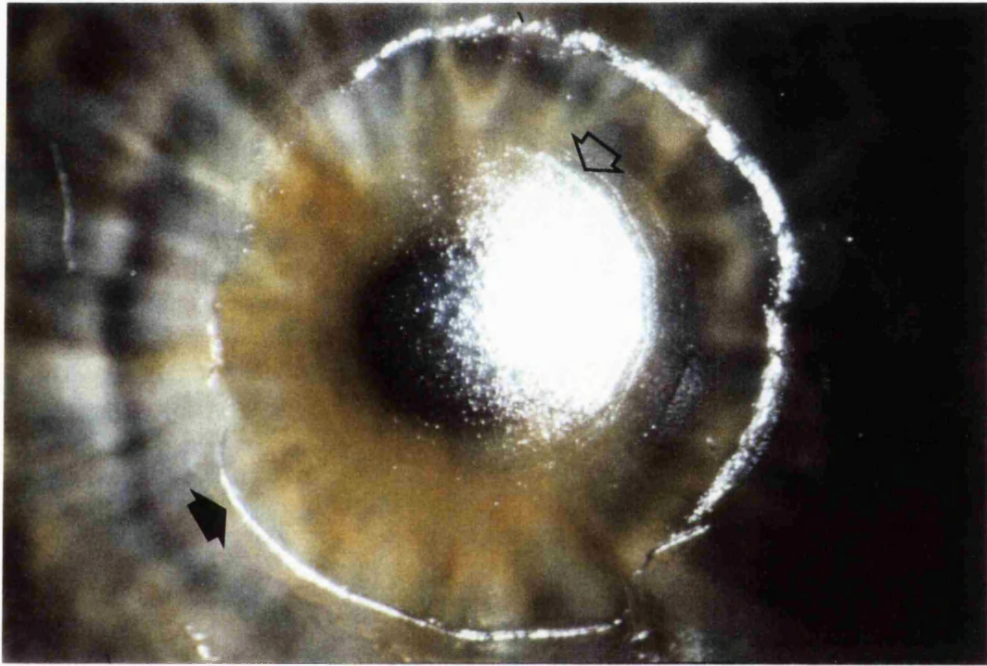

7.2.3 (a) The blind eye study

The 16 patients enrolled into this trial had visual acuity in one eye of 3/60 or less due to long-standing untreatable pathology. Careful preoperative assessment, to confirm that no improvement was possible (for example in previously uncorrected, unilateral high myopia) was undertaken. In addition to general ophthalmic examination, objective refraction (streak retinoscopy), autorefraction (Allergan Humphrey), keratometry, photokeratography and endothelial specular photomicroscopy (ESP) were carried out, where possible, as for the sighted eye study (vide infra). In all cases the eye to be treated had a normal anterior segment. During the procedure it was important that the target eye remained fixed for around 19 seconds (the predicted period of time for a -7.00 dioptre treatment). This was achieved by fixation of a light adjacent to the laser aperture with the non-target eye and it was therefore necessary for this eye to have a 'reasonable' level of vision (6/18 or better). Limited evidence at the commencement of these trials suggested that post-operative scarring of the anterior corneal stroma would be minimized by the use of topical corticosteroids post-operatively (Tuft et al, 1989b). Other studies had suggested also that scarring is more pronounced with deeper ablations (Marshall et al, 1986; Tuft et al, 1987; Taylor et al, 1989). Therefore, in an attempt to cause maximal scarring -7.00 dioptre corrections were performed (equivalent to an 'on-axis' ablation depth of 44 microns) and no topical corticosteroids were given.

7.2.4 (b) The Sighted Eye Study

Following referral prospective patients were sent a questionnaire and background information. This gave a brief history of the use of excimer laser in ophthalmology, an explanation of the surgical principles, and details of the patient follow-up commitment (14 planned visits in the first year). The research nature of the project was emphasised to ensure that prospective patients would have realistic expectations. The questionnaire was designed to allow selection of patients based on the criteria outlined in table VIII (opposite). Amblyopic patients and those in whom each eye could not be corrected to 6/9 (20/30) or better were excluded. The majority of patients included in the trial achieved 6/6 (20/20) or better in each eyes. Patients with a history of ocular pathology or surgery were excluded, as were diabetics, because of the possibility of fluctuation in refractive error and wound healing difficulties in general (epithelial wound healing in particular). Patients with a history of systemic illness, in particular connective tissue or collagen vascular disorders were also excluded.

Table VIII Patient selection criteria for PRK (original study)

PARAMETER	CRITERION
Refraction	Patients with myopia (all degrees) and a stable refraction. Patients with anisometropia included.
Astigmatism	Less than 1.00 dioptre of astigmatism.
Visual acuity	Best corrected visual acuity of 6/9 (20/30) or greater in each eye.
Age	Lower limit 24 years to increase the probability of a stable refraction.
Contact lens history	Contact lens wearers preferred due to the likelihood of induced anisometropia after PRK (mainly soft lens wearers enrolled). Patients with evidence of fluctuating refraction (optometric records scrutinised) due to corneal distortion were excluded.
Past medical history	Patients with a history of connective tissue disorders or collagen vascular disease and diabetes were excluded.
Occupation	Individuals with exacting vocational visual requirements were excluded (eg, pilots, professional drivers)
Ophthalmic history	Patients with a history of ocular disease (surface disorders and dry eye especially) or previous ocular surgery were excluded.
Motivation	Prospective patients were asked to state their reasons for wishing to be included in the study. Only those with realistic expectations were included.
Informed consent	Only those patients demonstrating a full understanding of the research nature of the study were enrolled. A detailed informed consent was signed prior to the surgery.

7.2.5 Assessment and examination

Following the 'questionnaire' and 'interview' stages suitable patients underwent detailed pre-operative examination. Pre- and post-operative examinations are listed in **Table IX** (opposite) and, with the exception of contrast sensitivity and video-imaging, were carried out by one observer (DSG) in order to provide maximum consistency in the data. An assessment of ability to maintain steady fixation during examinations, as required for example in endothelial specular photomicroscopy (ESP), was also made at this stage.

7.2.6 Study design - sighted eyes

Depending upon preoperative refraction patients were allocated to one of 6 treatment groups (-2.00D through to -7.00D in whole dioptre steps) with 20 patients per group. Within a group all patients had an identical PRK treatment, ie the same dioptre correction was attempted. This allowed assessment of healing of identical ablation depths within each group. The range of pre-operative myopia was -1.50D to -17.50D (spherical equivalent). Since the maximum treatment programmed was -7.00D, and around one fifth of the cohort had myopia in excess of this, only partial correction was attempted in these patients. Anisometropes were also included and therefore emmetropia was not the aim in every case. In order to evaluate individual variation all variables within our control were kept constant between patients : ablation rate (0.22 microns/pulse), diameter of ablation zone (4mm), surgical technique and post-operative treatment regimen (high dose topical corticosteroids for 3 months - see below).

7.2.7 The procedure (see figure 7.3 overpage)

Surgery was performed by 2 surgeons (DSG and MKM) using an identical technique. Prior to treatment a series of tests designed to confirm beam homogeneity was carried out. Sterile precautions were adopted as for any surgical procedure. Patients were allocated randomly to each surgeon. The importance of steady fixation was explained to the patient, the sound generated by the laser demonstrated and the patient warned to expect a smell similar to "burning" during the PRK procedure. A consent form was then signed (see appendix I). The eye to be treated was aligned 12 cm beneath the laser aperture and a pad to absorb excess eyedrops placed near the lateral canthus. The other eye was then taped shut to facilitate fixation.

Table IX

Schedule of investigations and follow-up for the original sighted eye PRK patients

Timing	preop	1/7	5/7	2/52	4/52	6/52	8/52	10/52	3/12	4/12	6/12	9/12	1 yr	18/12
Investigation														
Refraction	+		+	+	+	+	+	+	+	+	+	+	+	+
Retinoscopy	+		+	+	+	+	+	+	+	+	+	+	+	+
Autorefracton	+								+					
Keratometry	+		+	+	+	+	+	+	+	+	+	+	+	+
Photography	+	+	+	+	+	+	+	+	+	+	+	+	+	+
Halo measurement			+	+	+	+	+	+	+	+	+	+	+	+
Endothelial SP	+								+				+	
Slit-lamp exam.	+		+	+	+	+	+	+	+	+	+	+	+	+
IOP	+				+				+				+	
Contrast sensitivity	+			+			+		+		+	+	+	
Videomaging	+			+			+		+		+		+	

IOP = intraocular pressure

Endothelial SP = endothelial specular photomicroscopy

The patient practised fixating a target light within the laser aperture until this could be sustained for the predicted duration of the procedure, on average 14 seconds (see figure 7.3 opposite). Topical guttae amethocaine 1% and pilocarpine 4% were instilled. The noise and burn-like smell were demonstrated by exposing the corneal epithelium to a short series of pulses with a 4mm diameter beam. A maximum of 45 pulses was used (10 to 15 pulses in 3 separate bursts) equivalent to removal of 10 microns of epithelium. This also served to delineate the area of epithelium to be removed. A lid speculum was inserted and an area of central epithelium approximately 5mm in diameter removed with a no.64 Beaver blade. Bowman's layer was carefully wiped clean of debris with absorbent coated swabs (TM Ophtha-sticks, West Germany). This debridement took 2 to 3 minutes and in order that corneal hydration was altered minimally there was no flushing of the surface. Fixation was practised again before treatment. The assistant then programmed the following data:

- (1) the dioptre correction required**
- (2) the diameter of the ablation zone**
- (3) the 'ablation rate' (0.22 microns per pulse).**

The exposure was commenced by depressing a foot-switch. Accurate alignment of the eye throughout the procedure was critical and was facilitated by the 2 Helium Neon lasers, one at each side of the laser aperture. The intersect of these beams (which defined a position in the excimer beam equivalent to radiant exposure of 180mJ/cm²) was maintained on the corneal apex and having crossed, these beams then diverged to travel through the anterior chamber (see chapter 4, page 71). The constriction of the pupil by 4% pilocarpine ensured that the two beams appeared on the iris at "3 and 9 o'clock". During exposure the surgeon made small steadying movements and adjustments of the patient's head so that the symmetry of the Helium-Neon aiming beams in relation to the pupil was maintained. Immediately after the procedure the eye was examined at the slit-lamp biomicroscope and photographed. An assessment of the centration of the treated area in relation to the visual axis was made. In those patients with good fixation the concentric ring pattern etched onto the corneal surface was seen easily (figure 7.2, page 143).

Figure 7.3 The procedure

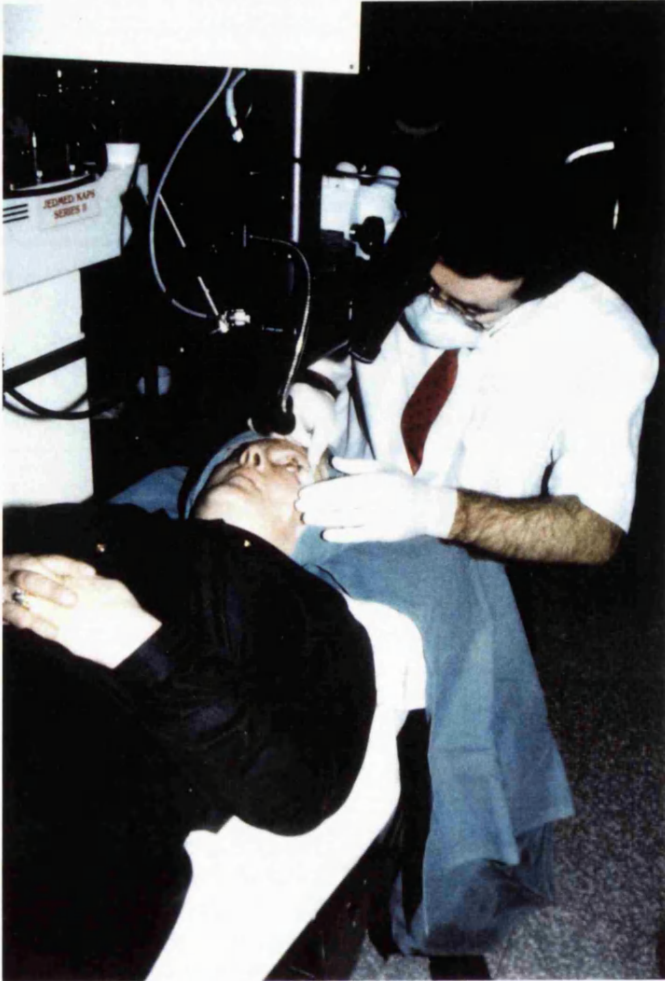

(a) The patient is positioned beneath the laser and sterile precautions observed by covering the head with sterile surgical drapes. The surgeon wears disposable gloves and a mask.

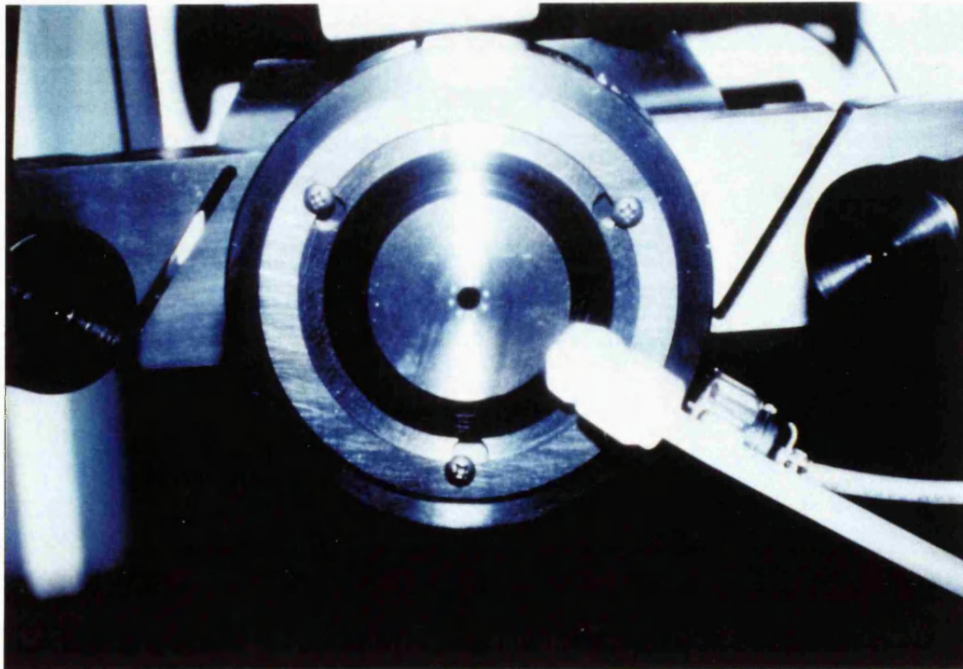

(b) The patient is asked to fixate the centre of a ring of green target lights arranged around the laser aperture

Figure 7.3 (ctd)

- (c) The patient then practises steady fixation until the surgeon is satisfied that he/she will be able to maintain fixation for the estimated time needed for the laser ablation.



- (d) Following instillation of topical amethocaine and pilocarpine, a lid speculum is inserted to allay any anxiety (on the part of either the patient or the surgeon) regarding the control of blinking or blepharospasm during the laser exposure.

Figure 7.3 (ctd)

- (e) The central corneal epithelium is then debrided with a scalpel over a diameter of approximately 5 or 6mm (to exceed the diameter of the ablation zone) and the surface is carefully wiped free of debris.



- (f) The parameters required are programmed into the laser by the assistant using the control 'touch pad'

Figure 7.3 (ctd)

(g)

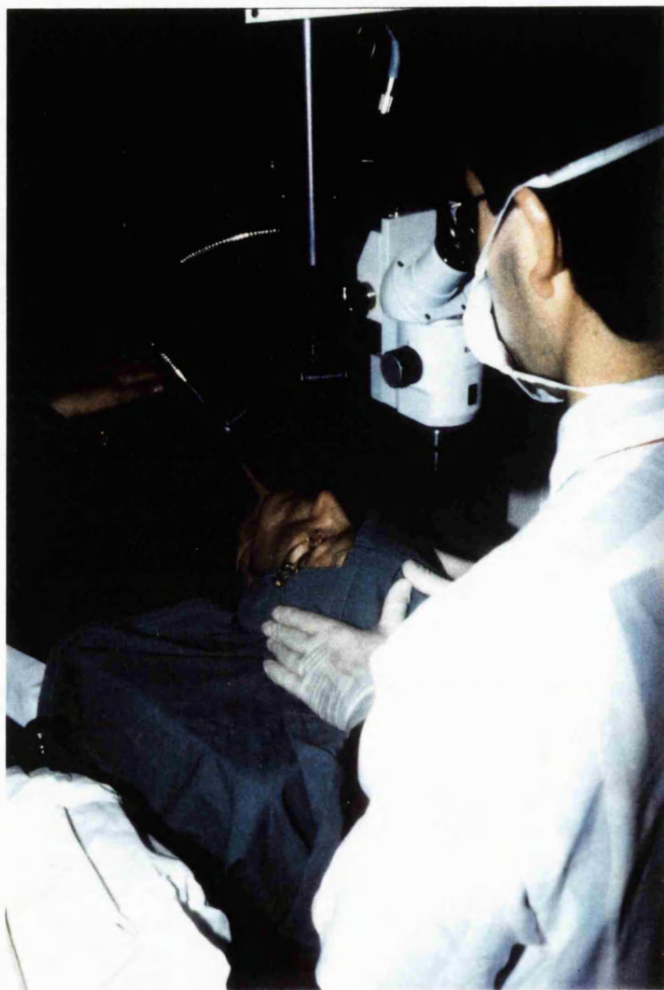

When the surgeon is satisfied that the alignment is optimal and the patient is able to fixate on the target accurately for the required length of time, the laser exposure is commenced using a foot pedal. Throughout the procedure alignment is maintained by the surgeon making small adjustments of the position of the patient's head in order to preserve the geometry of the helium-neon aiming lasers



Figure 7.3
(ctd)

- (h) The appearance of the corneal surface immediately after the treatment. The concentric ring pattern is evident as well as the irregular outer border of the zone of epithelial debridement.

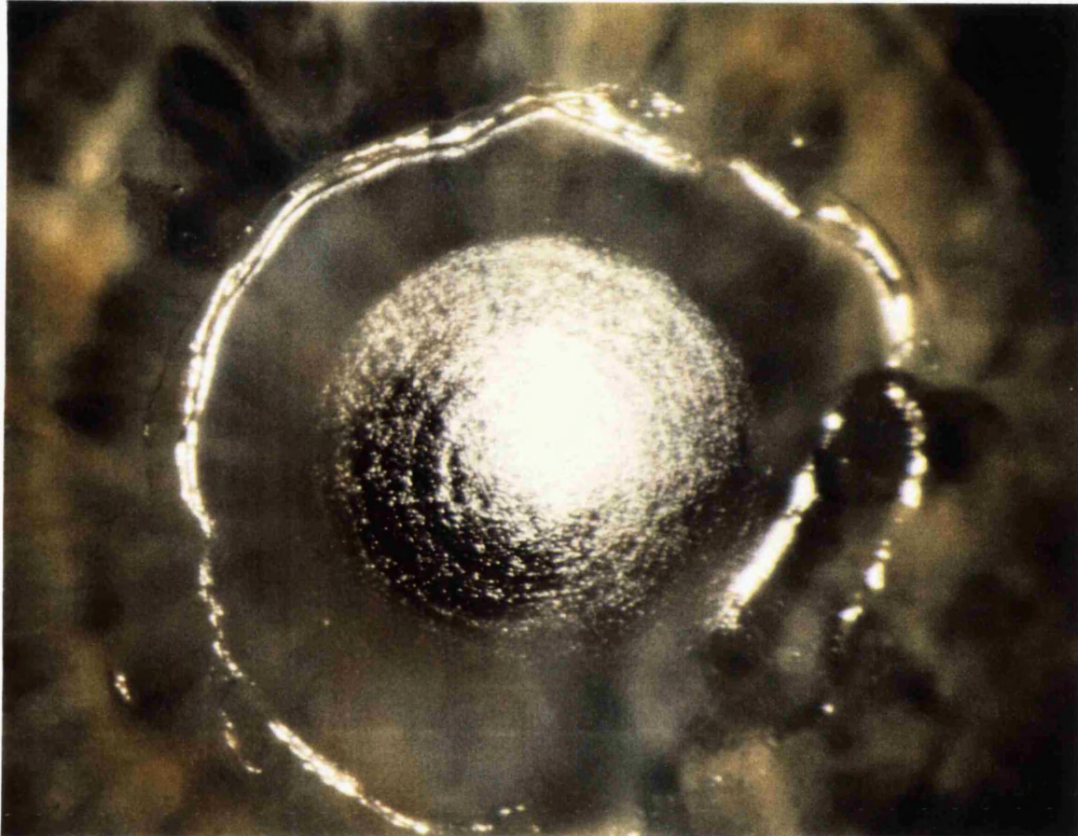

7.2.8 Post-operative management and monitoring

This differed between the blind and sighted groups because of the different objectives of the 2 studies.

In both groups topical guttae cyclopentolate 1%, phenylephrine 10%, homatropine 2%, and betamethasone with neomycin ointment were instilled following surgery and the eyelids taped shut. The eye was padded for an average of around 16 hours. Oral analgesics were given immediately after surgery (dextropoxyphene with paracetamol [Distalgesic]) with a supply for use at home if required.

A report that topical corticosteroids minimised corneal scarring (Tuft et al, 1989b) led to Ethics Committee constraints for the sighted eye study such that a fixed regimen of topical guttae dexamethasone 0.1%, 5 times per day for 2 months tapering over the third postoperative month, irrespective of refractive status or corneal clarity, was used. In 14 patients who demonstrated raised intraocular pressure (IOP) (corticosteroid responders), this regimen was abandoned, typically at the 6 to 8 weeks stage. In addition, 7 patients discontinued corticosteroids for other reasons, namely poor compliance and pregnancy. Both the blind and sighted groups were given topical guttae chloramphenicol 0.5% four times per day for 2 weeks postoperatively.

The follow-up intervals and assessment at each stage are summarised in Table IX. All refraction - both subjective and objective was carried out by one ophthalmologist with special expertise in this area (DSG). At each follow-up visit, no reference was made to previous results until after the refraction. Reliance was placed upon fogging techniques - in particular the +1.00 DS blur test - to ensure that an accurate end-point in subjective refraction was reached consistently. This test is based on the assumption that when an accurate subjective refraction end-point has been reached, addition of a further +1.00DS will "fog" the patient to around 6/18 (20/60). If, with this extra +1.00DS, Snellen acuity is significantly better than 6/18 then it is likely that too much minus power has been prescribed and the spherical component should be revised accordingly. It was unnecessary to use cycloplegia for accurate refraction and contraindicated because of the possibility of unwanted aberration effects from the paracentral cornea. An Allergan Humphrey autorefractor and a Javal-Schiotz keratometer were used throughout the study.

7.2.9 Assessment of aberrations

As stated above, the maximal diameter of the ablation zone used throughout the present study was 4mm and we anticipated that patients with large pupils might experience some aberration in low levels of illumination. (This problem is seen commonly in contact lens wearers who have been fitted with small diameter 'micro-corneal' lenses. Patients typically reported "scatter", "glare" or "ghosting" around lights at night. This was more accurately defined as a true "halo effect" which could be eliminated either by miosis, in which case central best visual acuity remained unaltered, or by placing an appropriate negative lens in front of the eye in which case visual acuity was reduced. By using the internally illuminated standard Snellen visual acuity chart against a dark background a subjective assessment of the magnitude of the halo effect could be made. Following accurate refraction at each post-operative visit, patients were asked to estimate the width of the halo in comparison to the width of the Snellen chart. Increasing powers of negative lenses were then placed in the trial frame until the halo was eliminated. The minimum power of minus lens required to eliminate the halo was recorded. In order to determine its effect on the magnitude of the halo an estimate of pupil size for each patient was made using a hand-held comparator (under the same clinical conditions used for measurement of the halo with the Snellen chart).

7.2.10 Assessment of corneal clarity

A clinical grading of anterior stromal haze (subepithelial scatter post-PRK has been termed "haze" by most authors) was made at each visit based on the following scale :

- 0 - no haze
- 0.5 - trace/just perceptible
- 1 - easily seen with slit-lamp
- 2 - moderate haze
- 3 - pronounced haze, iris details still visible
- 4 - "scarring", iris detail obscured (visible with pen torch)

After slit-lamp examination all patients had anterior segment photography (Zeiss). A standardised photographic technique, using direct illumination with a 1.5 mm slit beam and a fixed angle of 30° between observation and illumination axes, was found to highlight the "haze" and was used for monitoring in both studies (figure 7.4 opposite).

Figure 7.4 Representative photographs used to characterise and classify corneal haze.

- (a) Preoperative appearance - grade 0.
- (b) One week postop - Trace disturbance of transparency due to epithelial healing.
- (c) One month postop - grade 1.

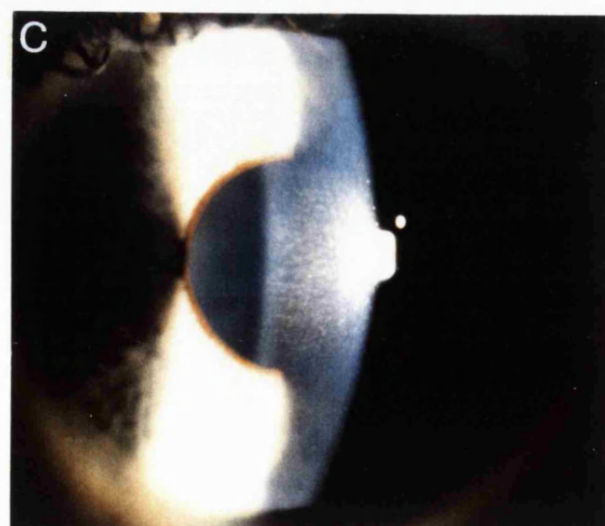
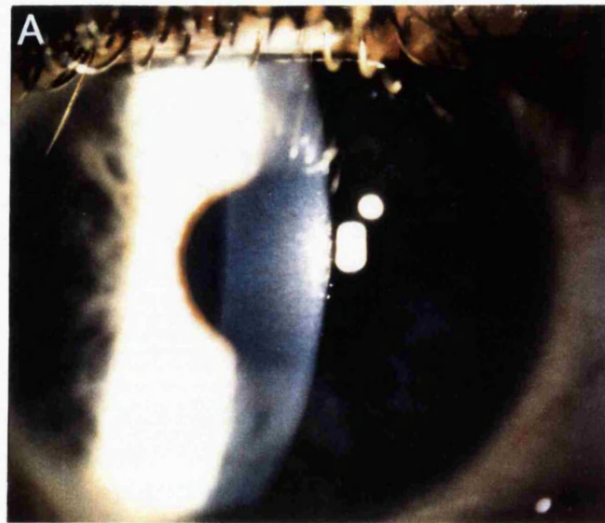
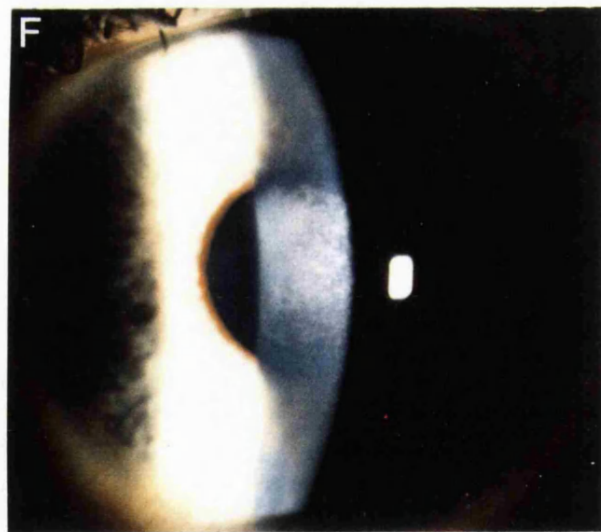
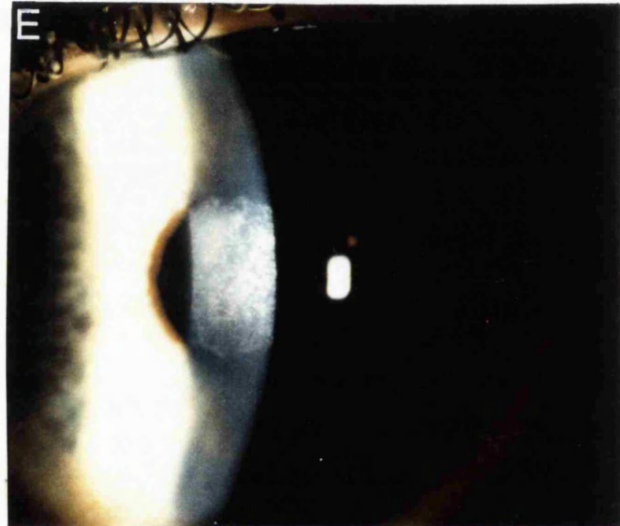

Figure 7.4 Representative photographs used to characterise and classify corneal haze.
(ctd)

- (d) Three months postop - grade 2.
- (e) Four months postop - grade 3.
- (f) Six months upper half grade 4, lower half grade 3.
- (g) Fine slit demonstrating location of haze at the level of the anterior stroma.



7.3 RESULTS

7.3.1 (A) The Blind Eye Study

The operation itself was painless. Fixation on the target to one side of the laser aperture with the sighted eye was adequate for the purposes of -7.00 D treatments (19 seconds duration). Patients variously reported mild discomfort through to moderately severe pain, which commenced, on average, 2 hours after the procedure. In none of the patients was this sufficiently severe to prevent sleep, however, the majority used 6 Distalgesic tablets and all cases improved considerably within 24 hours. Epithelial healing occurred rapidly with an average area of abrasion 3 mm in diameter 16 hours after surgery. Mild stromal oedema with a few Descemet's folds were present with a quiet anterior chamber at this stage. Padding was discontinued and treatment with topical guttae chloramphenicol 0.5% initiated. By 48 hours all patients were pain-free. Since the aim of the blind eye study was to gather information on the safety of the PRK procedure the limited refractive and keratometry data are not reported here. Once reepithelialisation had occurred there was no subsequent epithelial instability. Anterior stromal haze (subepithelial scatter) was first detected (grade 0.5) at 4 weeks and increased to between grade 1.0 and 2.0 by the sixth month. The haze cleared considerably (to an average grade 0.5) by 1 year. Endothelial specular photomicroscopy (ESP) was carried out pre-, per- and postoperatively. Peroperatively, acute changes in the endothelial cells were detected which lasted a few hours and formed the subject of a separate study***. All corneas remained clear with no evidence of longer-term endothelial dysfunction.

7.3.2 (B) The Sighted Eye Study

The studies on refraction, keratometry, visual performance and complications are reported here. The subjective response to surgery and the immediate postoperative phase were identical to that of the blind eye group. Re-epithelialisation took between 48 to 72 hours and all patients reported that the eye felt normal after 4 days. On the 4th day unaided vision was considerably improved compared with the preoperative level. By 1 week, all patients gave accurate subjective refraction responses and visual acuity was found to be reduced by, on average, one line. Best spectacle corrected visual acuity returned to preoperative levels by 2 weeks. On direct questioning no patient reported a diurnal variation in refraction.

7.3.3 Postoperative Refraction

A series of graphs relating mean change in refraction to follow up time are shown in figure 7.5 a-f (opposite). All patients had a significant decrease in myopia in the first postoperative week. A mean overcorrection was noted proportional to the magnitude of the attempted correction, e.g. in the -3.00D treatment group the mean change was 5.50 dioptres, while in the -7.00D group it was 10.25 dioptres. This overcorrection reduced progressively between the second and twelfth postoperative weeks. Regression occurred in some individuals in all groups beyond the 3 month stage but was much more common in the -6.00D and -7.00D groups (figure 7.5 e and f). In the -7.00D group the degree of immediate postoperative change was also related to the amount of preoperative myopia. In analysing data patients in this group were subdivided into those whose pre-operative refractive error was $< -10.00\text{D}$ (mean = -7.60D , $n = 10$) and those $> -10.00\text{D}$ (mean = -12.94D , $n = 10$) (figure 7.6 overpage). The mean change at the first postoperative visit for the former group was 9.00 dioptres (an over-correction of 2.00D), and for the latter group 12.25 dioptres (an overcorrection of 5.25D). The -2.00D, -3.00D, -4.00D and -5.00D groups demonstrated minimal change in mean refraction after the third month (figure 7.5 a-d). In contrast, in the -7.00D group a more marked regression towards the preoperative level occurred throughout the first 6 months after which mean refraction stabilised (figure 7.5f). Although the mean change in refraction achieved at 3 months in all groups was close to that intended, there was considerable individual variation (figure 7.7 overpage).

Figure 7.5 Graphs showing the mean change in refraction as a function of time for all 6 treatment groups (from -2.00D through to -7.00D). All patients show an overcorrection initially and regression within the first 3 months to a plateau phase with the exception of the high myopes. The error bars are ± 1 standard deviation (mean follow-up 18 months).

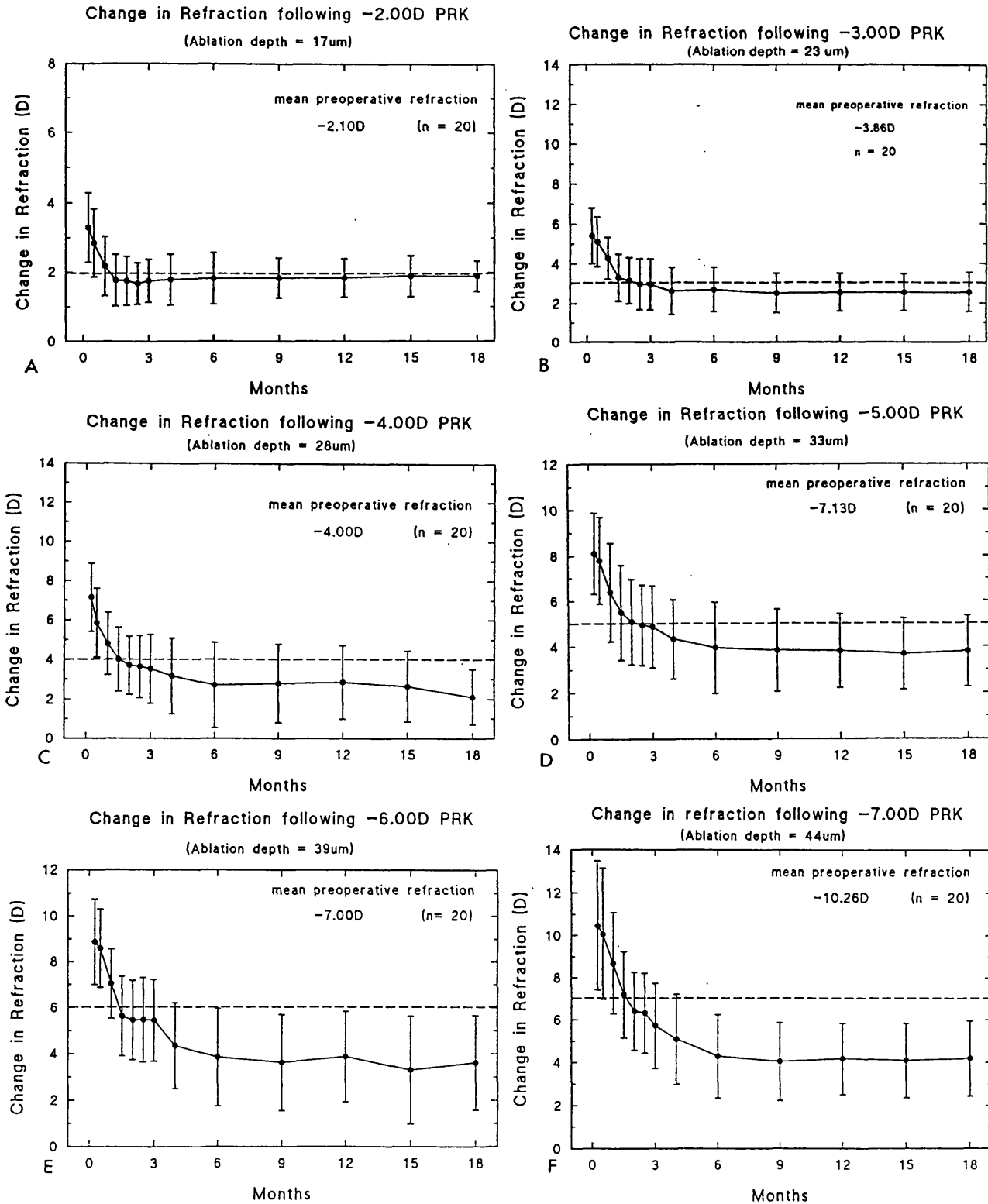

Figure 7.6 Mean change in refraction with time for patients undergoing -7.00D treatments. The solid line indicates those patients with a preoperative refraction greater than -10.00D while the dotted line represents those with preoperative refraction less than -10.00D.

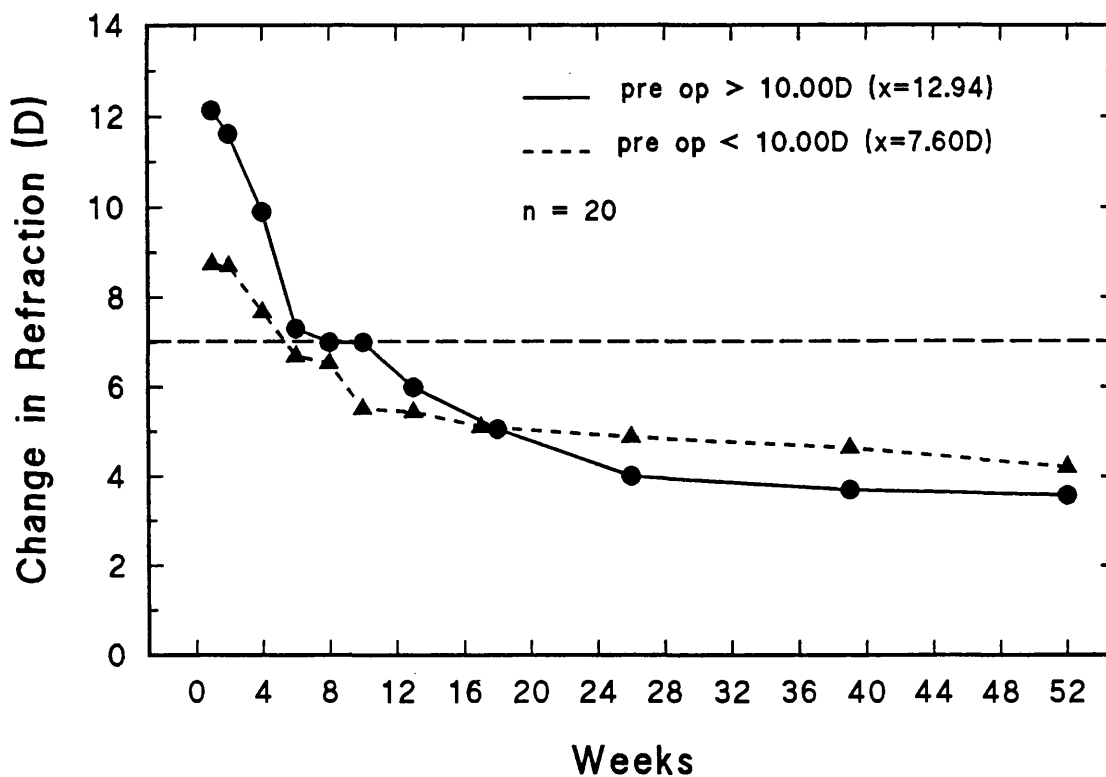
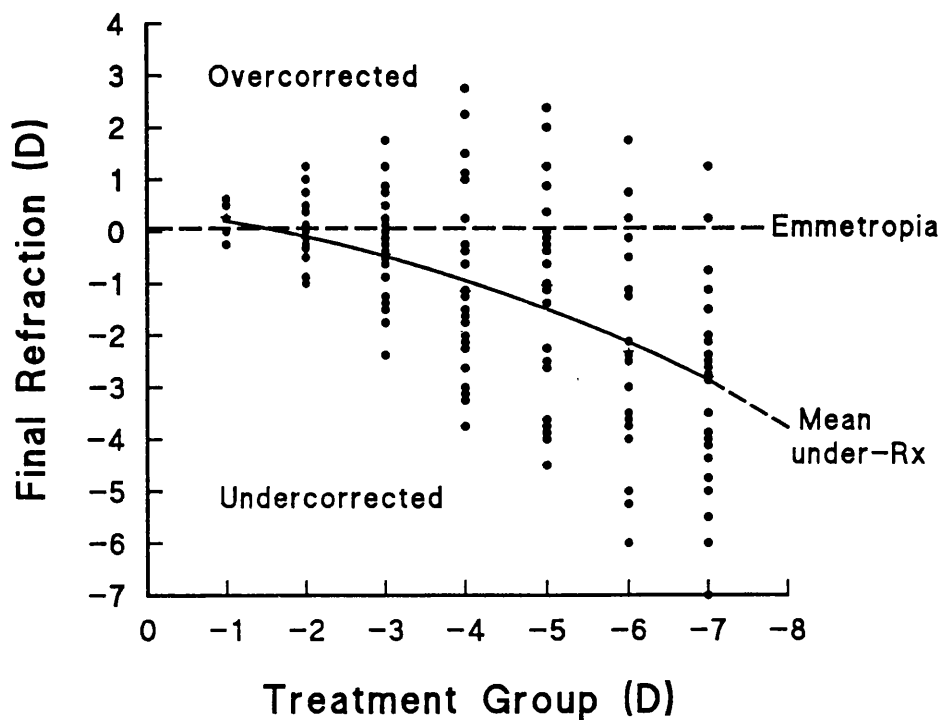
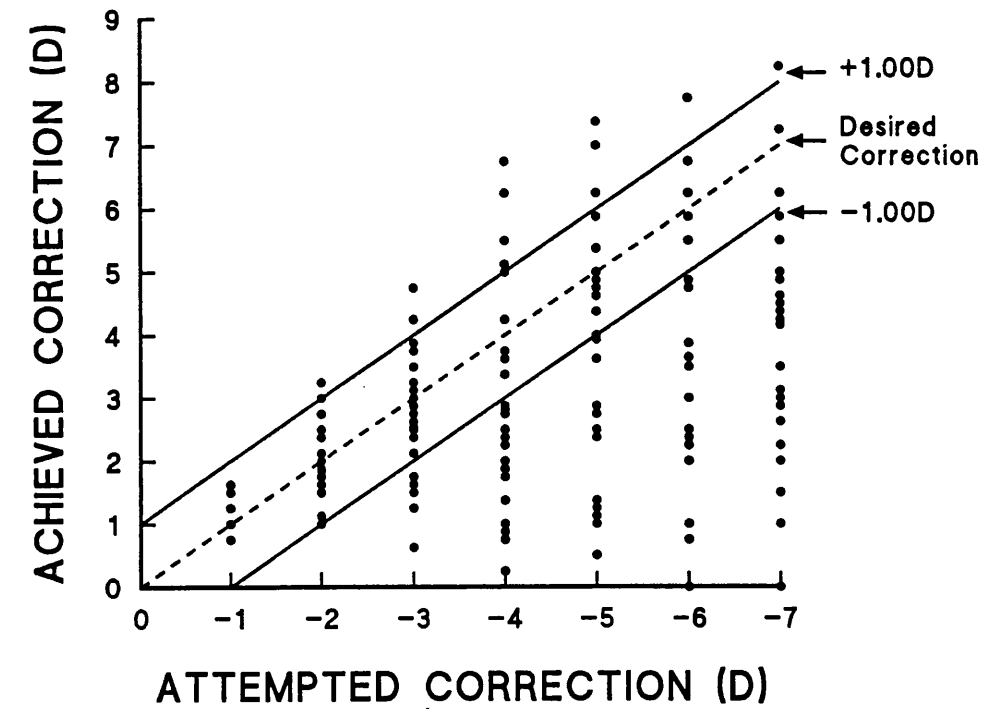

Figure 7.7 Scattergrams of attempted versus achieved correction
(all data points $n = 120$ at 2 year follow-up).

In the uppermost graph the 45° broken/dashed line represents the position at which attempted equals achieved and in the lower of the 2 graphs the curved solid line is the plot of the mean correction achieved. A consistent undercorrection is evident, which becomes proportionately greater with time for the larger corrections. Considerable individual variation is demonstrated within each treatment group but especially when larger corrections are attempted. These 2 graphs also show that some of the patients in the $-6.00D$ and $-7.00D$ groups have regressed completely back to their preoperative level.



7.3.4 Unaided vision

The refraction results at 18 months are summarised in table X (below) and the unaided vision, in those patients in whom a full correction was attempted, in table XI (opposite). There was a high direct correlation between keratometry and refraction. No statistically significant change in astigmatism was found when compared with the preoperative amount (2-tailed Student t-test $P > 0.05$). Retinoscopy was relatively easy to perform postoperatively and a well-defined central zone of altered reflex was clearly visible. The central "with" movement was surrounded by an annulus of "against" movement. Retinoscopy was most useful in the early post-operative period to confirm the amount of over-correction present, and, by ensuring that there was always adequate 'fogging', to minimise the tendency of the patient to accommodate prior to subjective refraction.

Table X Accuracy of photorefractive keratectomy (follow-up 18 months)

Treatment Group (D)	Patients within stated tolerances		Patients achieving > 1/2 attempted correction
	$\pm 0.50D$	$\pm 1.00D$	
-2.00	75%	95%	95%
-3.00	45%	70%	90%
-4.00	20%	40%	65%
-5.00	30%	50%	80%
-6.00	25%	40%	60%
-7.00	5%	20%	70%

Table XI Unaided vision 18 months after photorefractive keratectomy in those patients in whom the aim was to achieve emmetropia (n = 66)

Unaided vision	Treatment Groups (D)					
	-2.00 20 eyes	-3.00 9 eyes	-4.00 17 eyes	-5.00 8 eyes	-6.00 8 eyes	-7.00 4 eyes
6/4 to 6/6	55%	56%	47%	50%	25%	0%
6/4 to 6/12	90%	78%	59%	63%	63%	25%
6/4 to 6/24	95%	89%	76%	75%	75%	25%
6/4 to 6/60 or less	100%	100%	100%	100%	100%	100%



7.3.5 Visual Acuity and anterior stromal "haze" - Correlations

As expected, the irregularities of healing epithelium caused a slight reduction in clarity in the first postoperative week. After this the cornea was clear until the 3 to 6 week stage when a faint, diffuse subepithelial stromal haze appeared which increased to a maximum by 6 months. This change in corneal clarity ("haze") was detected in 110 patients (92%) by the third month. The magnitude and time course of this haze, as determined by our subjective grading method, are shown in figure 7.8 (opposite). There was only limited statistical correlation of haze with age ($R = -0.32$) and poor correlation with ablation depth ($R = 0.22$) in spite of the clinical impression that older patients demonstrated less haze and higher order corrections (deeper ablations) resulted in more marked haze. There was good correlation however between haze and the regression of refraction (R values for the $-2.00D$ to $-7.00D$ groups = 0.49, 0.75, 0.83, 0.36, 0.86 and 0.76 respectively ; mean correlation = 0.68). In addition, in those patients in whom correction should have produced emmetropia ($n = 66$) unaided vision was highly correlated with residual ametropia at one year ($R = 0.94$).

At one year 98 patients (82%) had best spectacle corrected visual acuity equal to or better than preoperative visual acuity. Eighteen patients (15%) lost between 1/2 and 1 line of Snellen acuity while 4 patients (3%) lost 2 lines (figure 7.9 below and table XII overpage). These 4 patients had undergone either $-6.00D$ or $-7.00D$ procedures (ablation depths of 39 and 44 microns respectively).

Figure 7.9

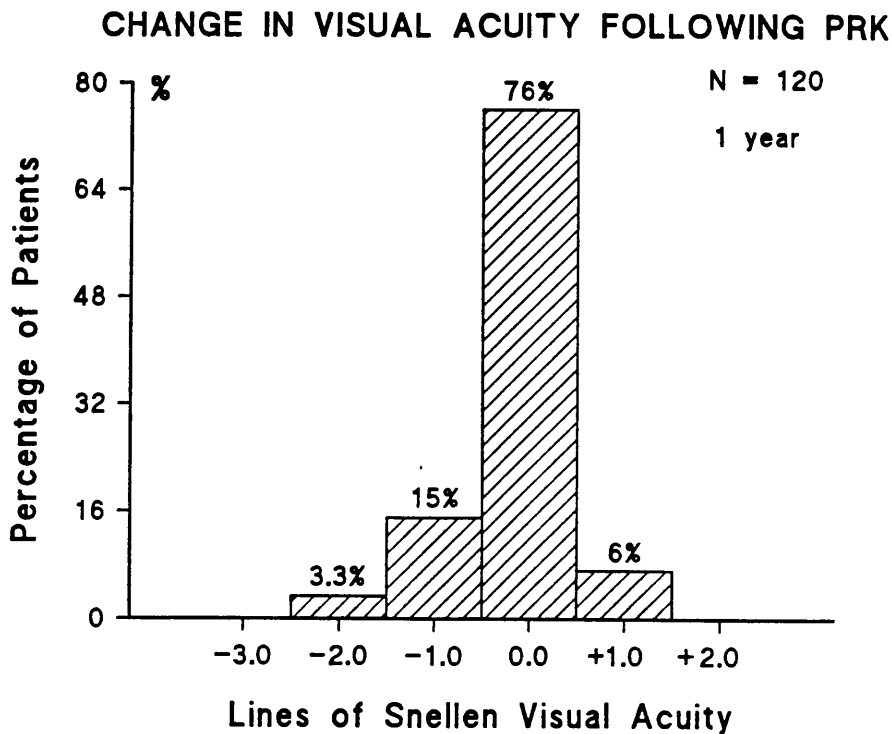
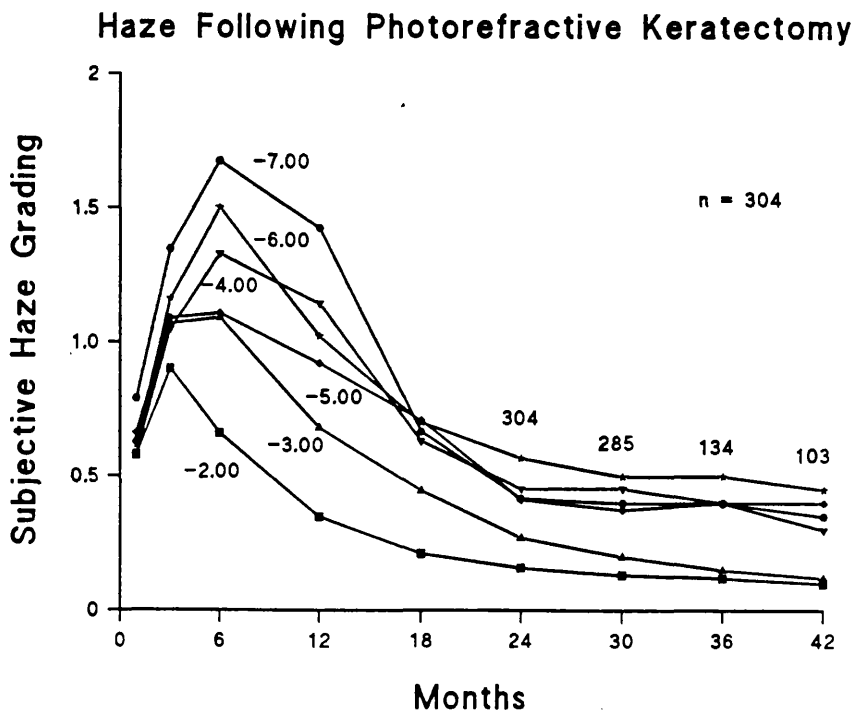
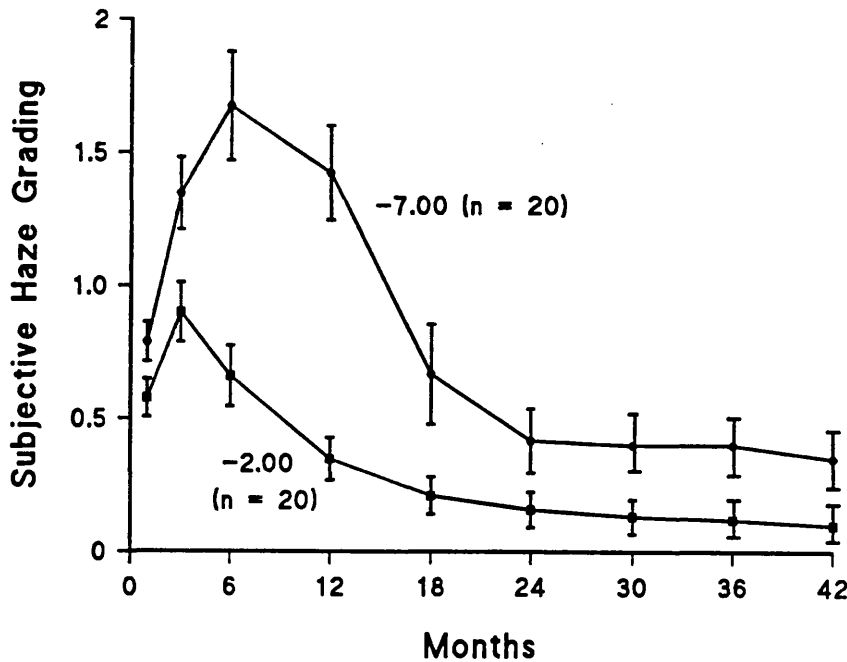

Figure 7.8 The magnitude and time course of anterior stromal haze after PRK.

The uppermost graphs reveal the difference in magnitude of haze between those patients with low myopia (-2.00D) and those with greater degrees (-7.00D). Error bars are ± 1 standard error of the mean. Haze increases to a maximum at around 6 months and then gradually diminishes. The strong clinical impression that haze is correlated with amount of correction is not borne out by statistical analysis because of the large variance in the data (wound healing differences) however see section V, chapter 8, where larger numbers of patients in the -3.00D and -6.00D groups reveal a highly significant relationship.



7.3.6 Side effects/complications

Table XII (opposite) identifies complications and their percentage incidence. The one case of significant decentration of the ablation zone occurred in the third patient to be treated. Fixation was maintained but viewing angle altered when the patient moved steadily away from the surgeon. This could have been avoided by interrupting the treatment until the patient was repositioned. This patient experienced a greater amount of halo effect (vide infra) below lights which gave rise to difficulty driving at night. Fourteen patients (12%) had a measurable rise in intra-ocular pressure (IOP) detected at the 4 to 6 week stage (topical corticosteroid responders). Of these, 3 reported transient loss of vision on rising rapidly from a chair and were found to have an IOP in excess of 45 mmHg. Topical corticosteroids were discontinued and IOP returned to normal within 2 weeks. Those with IOP in excess of 30mmHg were treated with topical Timolol maleate 0.25% twice a day for 1 month.

7.3.7 Halo Effect (low illumination positive spherical aberration)

On direct questioning 94 patients (78%) reported haloes around sources of light at night in the early postoperative period. The magnitude of this halo effect was highly directly correlated with pupil size ($R = 0.79$) and the amount of the induced refractive change ($R = 0.71$) (figure 7.10 a and b overpage). Those patients with greater overcorrection in the early postoperative phase experienced the most marked halo effect. With regression in refraction in the first 3 months subjective appraisal of the halo effect and a reduction in the power of the negative lens required to eliminate it indicated that the magnitude of the halo became less with time. However, at one year 12 patients (10%) found that the effect persisted and was severe enough to interfere with night driving. They therefore declined to have the other eye treated. The effect was found to be unrelated to the magnitude and time course of the anterior stromal haze.

Table XII Complications of photorefractive keratectomy at 18 months

Complication	Percentage incidence	Comment
Anterior Stromal Haze	95%	Detected at the 3 to 4 week stage, maximal at around 5 to 6 months then begins to fade (in some cases forming a reticulated scar)
Night Halo effect	78%	More marked in the first few months; directly proportional to pupil size and correction achieved; inversely proportional to regression
Halo effect a major problem	10%	Considered sufficiently problematic to prevent the patient seeking to have the second eye operated
Snellen acuity lost: 1/2 line 1 line 2 lines	7% 8% 3%	Loss of high contrast Snellen best corrected visual acuity (BCVA); a faint veiling haze or loss of definition described by the patient
Tenderness on rubbing the eye	25%	More marked in the first 3 months; settles with time
Foreign body sensation on waking	20%	More frequently reported in the first 6 months; discomfort is short-lived usually
Increased IOP	12%	Between 2 to 6 weeks post-PRK; topical corticosteroid-related
Epithelial instability	2.5%	3 patients reported single episodes of pain on opening the eye; epithelial breakdown and rapid reepithelialisation documented
Epithelial iron lines	28%	Usually located at the lower border of the ablated area; similar to Hudson-Stahli lines
Decentered ablation zone (by 1.5mm)	1%	Due to patient movement during the procedure

IOP = intraocular pressure

Figure 7.10 Night 'halo' effect - correlations

(a) Correlation between the magnitude of the 'halo effect', as measured subjectively and pupil size (all patients at the 6 week visit)

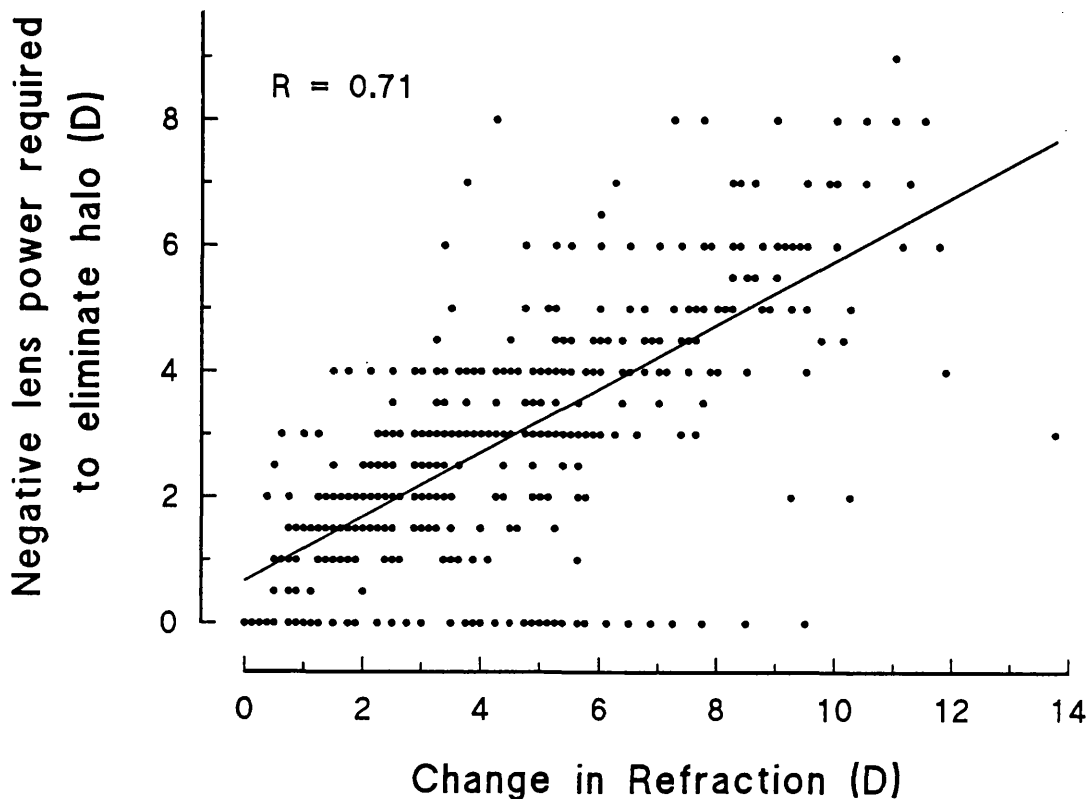
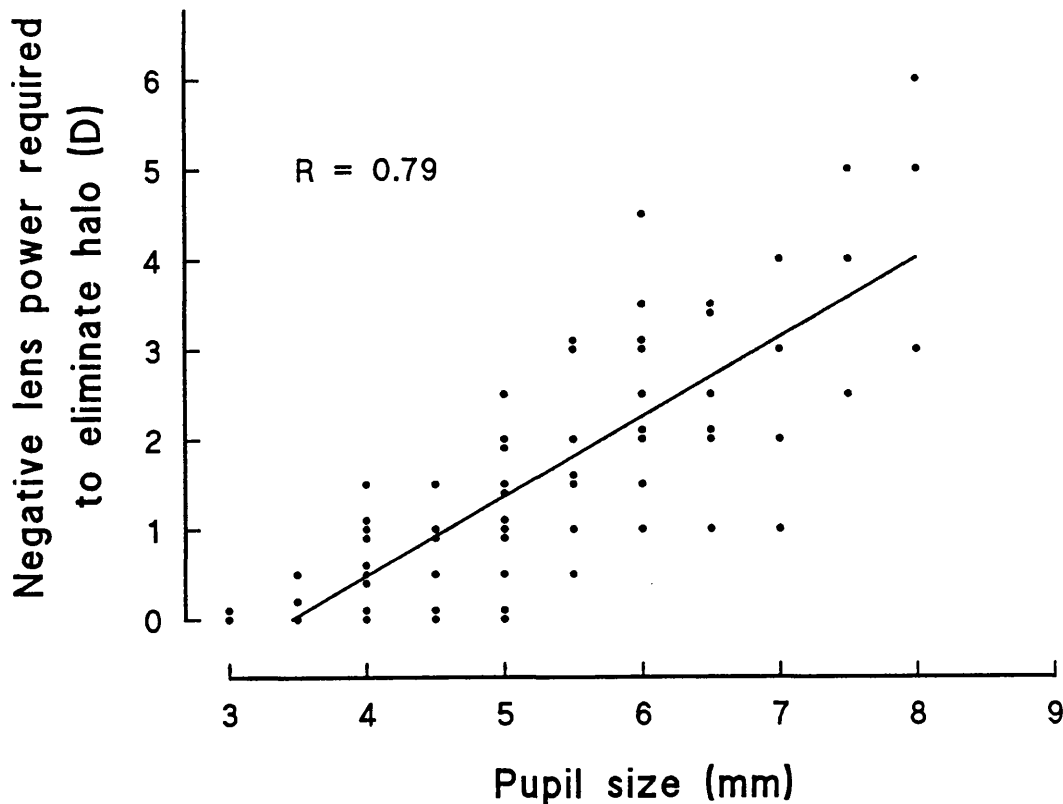

(b) Correlation between the magnitude of the 'halo effect', as measured subjectively, and change in refraction (all visits up to and including the 3 month visit)

7.4 DISCUSSION

7.4.1 Study Design

For PRK to become an accepted procedure the induced correction must be within predictable limits and be relatively stable. Most importantly, there must be no significant deficit in visual performance. In order to gain information on individual variation in corneal wound healing response to standard ablation depths, the current study was designed to collect data in a systematic fashion with as many variables as possible kept constant.

7.4.2 Refractive outcome and regression

From figure 7.5 a-f (page 167) and table X (page 172) it can be seen that the accuracy of PRK diminishes considerably as larger corrections are attempted. This could be explained by either :

- 1) an error in the algorithm which would be cumulative with the larger number of pulses necessary for higher order corrections,
- 2) differential ablation rates in different levels of superficial stroma,
- 3) the angle of slope at the edge of the ablation site or
- 4) more marked tissue healing responses resulting from deeper ablations.

In relation to each of these issues : 1) the algorithms can be progressively modulated as statistically valid data become available, 2) there is some indication that ablation rate may vary with tissues, and with hydration levels within tissues, but in cornea these effects are minimal (Seiler et al, 1990a), 3) for any given ablation zone diameter the edge angle will increase with increasing correction and a steeper angle may lead to more marked cellular responses, and 4) it is probable however that, in the main, deviations result from epithelial and stromal wound healing processes. At 18 months, 95% and 70% of patients who underwent -2.00D and -3.00D corrections respectively had refractions within $\pm 1.00D$ of the intended result. In the -6.00D and -7.00D groups 40% and 20% respectively were within $\pm 1.00D$ (Table X). The greater regression in these groups may relate to the elastic properties of different collagen in such eyes (Weale, 1982). Early results indicated more regression in patients greater than -10.00D undergoing the same correction (-7.00D) as those less than -10.00D however there is no statistically significant

difference between these groups beyond 2 months (figure 7.6, page 169). A large number of patients who remained undercorrected once stabilisation had occurred reported a high level of satisfaction with the results due to an improvement in unaided visual acuity and less absolute dependence on spectacles or contact lenses. While around 70% of those undergoing a -3.00D correction were within $\pm 1.00D$ of intended refraction at 18 months, 90% achieved a reduction of myopia of more than half that intended. Even in the -7.00D treatment group 70% achieved a correction of at least 3.50D (table X). The high level of satisfaction expressed by these patients is not conveyed in any representation of the data in terms of their final proximity to emmetropia.

7.4.3 Unaided vision post-PRK

The uncorrected visual acuity after stabilisation varied with the amount of correction attempted. In those patients in whom attempted correction should have resulted in emmetropia ($n = 66$), uncorrected visual acuity of 20/40 or better was achieved in 90%, 78%, 59%, 50%, 63% and 25% in the -2.00D through to -7.00D groups respectively (table XI, page 173). We have found that, as for subjective refraction in unoperated eyes, unaided visual acuity following PRK is highly correlated with residual ametropia ($R = 0.94$). This suggests that corneal shape within the ablated zone is altered minimally. This is not the case following radial keratotomy in which irregular astigmatism and a multifocal cornea can lead to difficulty in predicting the unaided visual acuity from the postoperative refraction (Holladay et al, 1991).

7.4.4 Stability of Refraction

In common with other groups (Seiler et al, 1990b; Liu et al, 1990; Zabel et al, 1990) we have demonstrated that a significant overcorrection is common in the early postoperative period which gradually diminishes until the twelfth to fifteenth week (figure 7.5a-f, page 167). Rapid regression in the immediate postoperative phase occurs mainly due to the build up of epithelial cell layers. This explanation is supported by the patients with single episodes of epithelial instability 10 weeks after surgery who were noted to have reverted to the overcorrected state and subsequently regressed as before (table XII, page 177). We suggest that it may be possible to manipulate the contour of the ablated surface (by altering the algorithm) to control this 'epithelial factor'. There was no significant change in refraction after 3 months in the -2.00, -3.00, -4.00 and -5.00 dioptre groups. In the -7.00D group (figure 7.5f) however, there was typically 2 dioptres of regression in the

period from 3 to 6 months at which point mean refraction then stabilised. Some regression must be due to stromal remodelling as supported by the correlation of haze with regression (mean correlation coefficient for all groups = 0.68). This process may operate over an extended time period (at present greater than our animal follow-up period and our medium term objective measurements of haze) (Marshall et al, 1988; Tuft et al, 1987; Lohmann et al, 1991a and 1991b). Pharmacological manipulation may improve predictability by controlling this remodelling.

7.4.5 Sub-epithelial haze - Correlations

Since PRK is undertaken on healthy eyes and is confined to the optical zone of the cornea any change in postoperative transparency is of concern. Several reports have highlighted varying degrees of anterior stromal haze following PRK (Marshall et al, 1988; Tuft et al, 1987 and 1989; SundarRaj et al, 1990; Fantes et al, 1990; Hanna et al, 1990; Malley et al, 1990; Del Pero et al, 1990). This haze results from changes in the substructure of the stroma and in some reports has been termed "scarring". Others have reserved the term scarring for a grade 4 opacity (Seiler et al, 1990b). Because of this subjective variation we developed a system for objective assessment of corneal clarity during the course of the present study and the results were correlated with our psychophysical measures of contrast sensitivity (Lohmann et al, 1991a and 1991b). We confirm that haze is a consequence of PRK and in 22 individuals (18%) resulted in high contrast visual loss. Eighteen of these (15%) lost between 1/2 and one line of best spectacle corrected visual acuity while 4 patients (3%) who had undergone either -6.00 or -7.00 dioptre corrections (39 and 44 micron ablation depths respectively) lost 2 lines. No patient lost more than 2 lines (some authorities consider the loss of 1 line of Snellen acuity to be clinically insignificant in relation to the error variance of the test (Kremer and Marks, 1983; McGraw et al, 1995). There was, therefore, no demonstrable reduction in best spectacle corrected visual acuity (BCVA) in 98 patients (82%) and 8 of these demonstrated an improvement, presumably due to increased retinal image size. It could be argued however that, since a large number of the patients in this study achieved a significant reduction of their myopia, a greater percentage should have experienced an improvement in their BCVA due to this increase in retinal image size. It could also be argued therefore that where best corrected visual acuity remains the same then, in real terms, this actually represents a slight reduction in BCVA.

In some instances the time course for the development of reduced corneal transparency is also of interest. On clinical assessment haze was maximal at between 4 to 6 months and improved thereafter (figure 7.8, page 175). However, on psychophysical assessment of visual acuity at various contrast levels most patients demonstrated an initial deficit in visual acuity at low contrast (5%) which returned to normal by 14 weeks (although the number of patients monitored in this cross-sectional study was small) (Lohmann et al, 1991). Histopathological studies have demonstrated that, while most cellular activity after PRK has settled by the third month (Marshall et al, 1988; Tuft et al, 1987; Tuft et al, 1989a), longer term changes are still present at 18 months (SundarRaj et al, 1990; Hanna et al, 1990). While our clinical impression is that haze is related to attempted correction (ablation depth), in the present study we have found only poor correlation ($R = 0.22$) in agreement with earlier studies in monkeys (Fantes et al, 1990). [In our randomised trial of topical corticosteroid versus placebo however, in which there were 2 discrete ablation depths (-3.00D and -6.00D corrections) with over 50 patients per group, the greater amount of haze with the -6.00D ablations was shown to be highly statistically significant ($p < 0.001$) - see section V]. In addition, we have been unable to demonstrate a statistically significant correlation between haze and the amount of pre-existing myopia. There is, however, a good correlation overall between magnitude of haze assessed subjectively and regression towards the preoperative refraction ($R = 0.68$; mean for all groups).

For vision to be compromised by corneal haze there must be significant disturbance of light transmitted to the retina. For example, if light passing through a treated area during the early postoperative period underwent forward scatter the retinal image would be degraded. This would not necessarily result in significant back scatter or reflection of light that could be detected by the ophthalmologist. By contrast, the increased haze at 6 months may result from reflection and back scattered light which, whilst disturbing for the examiner, may have a smaller effect on visual acuity than anticipated (Lohmann et al, 1991b). An analogy can be made with 'the net curtain effect' in that if an individual sitting in a dark room (equivalent to the inside of the eye) looks at a brightly-lit street outside his view is almost unimpeded by a net curtain. This is in marked contrast to the view that an observer would have of the room from the street since he would only be able to see the reflected light from the net curtain (equivalent to the corneal haze seen by direct illumination). This concept is demonstrated in figure 7.11 opposite.

Figure 7.11 Anterior segment photographs 6 months after PRK.

- (a) Using diffuse illumination a well-defined area of anterior stromal haze is seen by back-scatter and reflection of light'

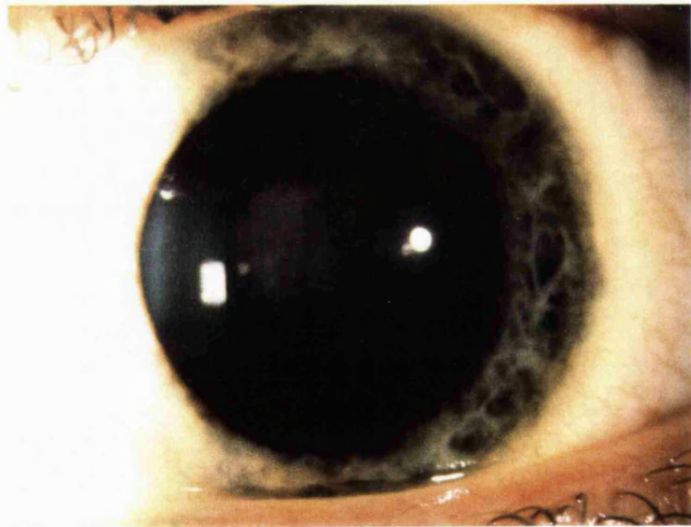

- (b) The same eye as above illuminated using sclerotic scatter. The effect from 'true scatter' within the cornea is highlighted and is much less obvious than in (a).

7.4.6 The role of topical corticosteroids?

Virtually all clinical trials have incorporated a topical post-operative corticosteroid regimen and some studies have suggested that regression and haze can be controlled by titration of dose (Seiler et al, 1990b and 1991). None of the patients in our blind eye study used topical corticosteroids (Gartry et al, 1991b; see p 144). They were, on average, older than those in the sighted eye group, however, haze was significantly less in spite of the -7.00D maximum corrections attempted. In addition, 21 patients in the present study discontinued corticosteroids, on average 4 weeks after the procedure, for a variety of reasons (increased IOP, poor compliance, pregnancy). There was no significant difference in outcome in this group. The small sample precludes calculation of meaningful confidence limits, but these findings suggest that corticosteroids may have little, if any, beneficial effect on corneal transparency or refraction. Given that 14 patients experienced raised IOP (steroid responders) it would be of some advantage if such treatment could be avoided. To clarify these issues a randomised, prospective, age-matched, double-blind study of 'with and without steroids' in a further 113 patients was designed (Section V).

7.4.7 The "Night Halo" Effect

The halo effect is due to refraction of light by the untreated paracentral cornea beyond the central 4mm diameter ablation zone. When the pupil is wider than 4mm in diameter this results in a myopic blur circle superimposed on the corrected image from the central cornea (figure 7.12 opposite). This is an extreme example of positive spherical aberration and, as predicted, there is a high correlation with pupil size ($R = 0.79$) (figure 7.10a). A total of 94 patients (78%) reported some halo effect in the early post-operative period. The effect diminished with time and by one year had either disappeared completely or was regarded as only a minor problem by 84 of these patients. In 12 patients however (10%) the effect was persistent and sufficiently problematic to prevent treatment of the other eye at the one year stage, as had been planned, because of the possibility that night vision might be permanently compromised. Since the halo effect is dependent on the difference between central and paracentral cornea, its magnitude is proportional to the induced refractive change ($R = 0.71$) (figure 7.10b) and therefore diminishes with time as regression proceeds. The lack of correlation with the magnitude of anterior stromal haze is further evidence in support of an optical aberration as a basis for the phenomenon rather than true scatter within the central treated zone.

Figure 7.12 Diagram showing the optical principle underlying the influence of pupil size on the night 'halo' effect.

- (a) While the pupil is constricted the light rays passing through the paracentral cornea are prevented from reaching the retina.

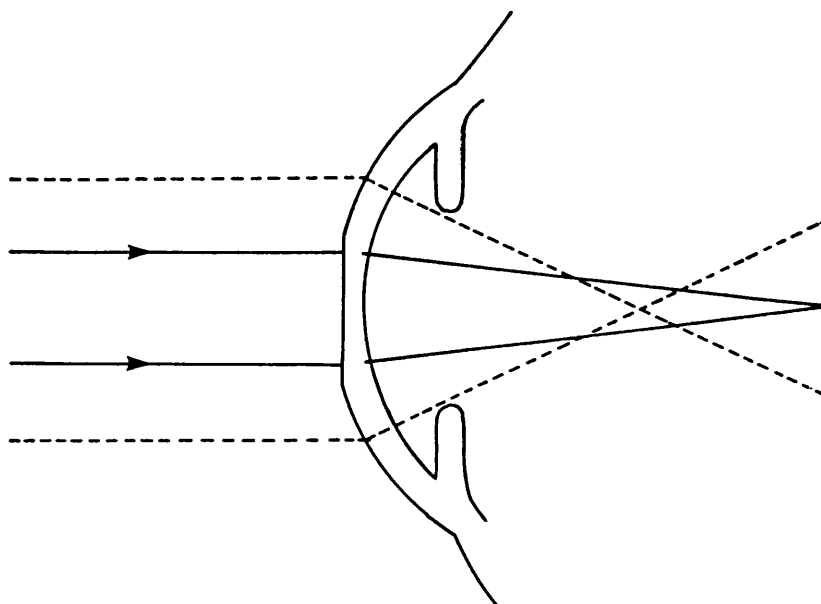
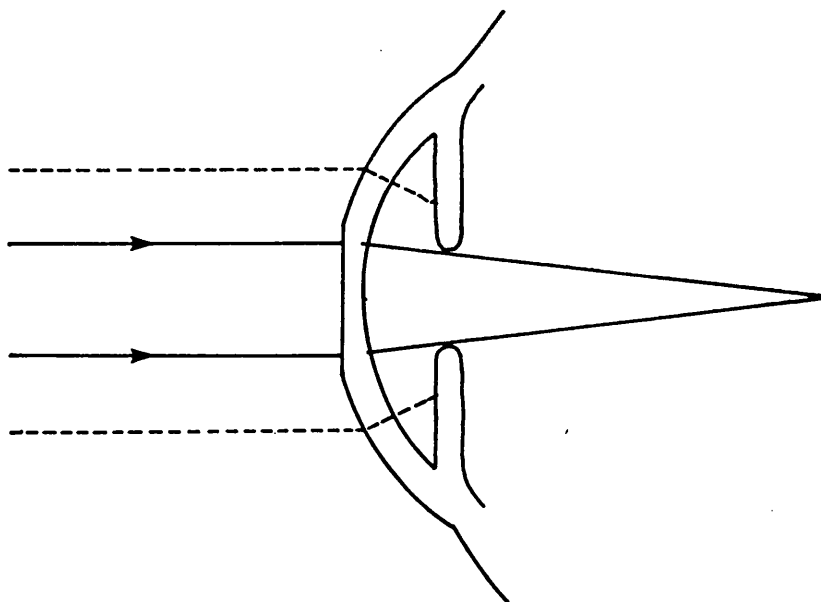

- (b) When the pupil dilates the rays traversing the untreated paracentral cornea can produce a myopic blur circle superimposed on the focused image from the corrected central cornea.

7.4.8 Autorefraction

A further consequence of the 4 mm diameter ablation zone was that autorefraction consistently overestimated postoperative myopia and in our study was abandoned. We have demonstrated that the magnitude of the halo effect can be monitored using negative lenses and it has been helpful in 3 cases to supply low powered minus lenses for night driving. Halos are the principal visual problem following PRK and we predict could have been reduced, or eliminated in some cases, had we been able to use an ablation zone larger than 4mm in diameter. The ablation depths would then have been concomitantly greater.

7.4.9 General Comments / Comparison with radial keratotomy

PRK differs from other forms of refractive surgery in that it is a "no-touch", computer controlled technique in which the corneal surface is directly reprofiled. Sighted eye trials commenced only 2 years ago and it seems likely that, as the databases from all centres using a given system can be used to adapt beam modulating algorithms, predictability will improve with time. The surgical skill required relates mainly to alignment during the procedure which is critical and is achieved by practice by both the patient and the surgeon. It is important that minor corrective movements to the patient are made during the laser exposure to ensure that alignment is maintained. This is facilitated by the geometry of the helium-neon aiming beams (figure 4.4, page 71). It can therefore be anticipated that the "learning curve" period and the influence of individual surgeons will be less with PRK than with other forms of refractive surgery.

PRK would seem to be inherently safe and completely obviates micro-perforations, deep scarring and weakening of the globe as occurs in radial keratotomy. The sterile field (ultra-violet radiation) and limited penetration can also be expected to minimise the risk of infection, although any breach in the normally intact epithelium would, under normal circumstances, be associated with the risk of infection. The procedure is associated with moderately severe pain in the first 12 to 18 hours but we have not demonstrated long-term discomfort. Undercorrection is more marked in the higher myopes in both procedures. We have been unable to demonstrate either "hyperopic drift" with time or induced astigmatism. The 5 year PERK study reported an increase in astigmatism of more than 1.00D in 15% of patients, the largest change being 4.50D (Waring et al, 1991). No patients in the present study reported diurnal variation as compared with an

increase in myopia during the day of up to 1.25D following radial keratotomy (Waring et al, 1987). Best spectacle corrected visual acuity (BCVA) is greater than, or equal to, preoperative levels in 82% of patients in this series. Fifteen percent lost only between 1/2 to one line of Snellen acuity. This is interesting since the optical zone is directly reprofiled. This would also suggest that corneal haze, seen in 92% of our patients, is not directly related to reduction in best spectacle corrected visual acuity.

Conclusions

In conclusion, our study has revealed considerable individual variation following PRK. Patient satisfaction, however, has been high, particularly for corrections of -4.00D or less in which predictability has been found to be fair. Longer follow-up from centres using progressively adapted algorithms is required to ascertain whether predictability can be improved. In addition, given that this initial cohort has a mean follow-up approaching only 2 years, we feel that PRK for low degrees of myopia is safe and the principal side effects are generally well-tolerated.

In the light of our findings we hypothesised that pharmacological manipulation might allow manipulation of corneal wound healing in the first few months following PRK and our double-blind trial, designed to investigate the role of topical corticosteroids post-PRK, is described in the next section (section V).

SECTION V

PHARMACOLOGICAL MANIPULATION OF WOUND HEALING AFTER PRK

CHAPTER 8

THE ROLE OF TOPICAL CORTICOSTEROIDS IN PRK

8.1 INTRODUCTION

8.1.1 Aims of the study

The aim of the study presented in this chapter was to determine whether topical corticosteroids administered in the early postoperative period have a beneficial effect on refractive outcome, the development of anterior stromal haze or the incidence of other complications following photorefractive keratectomy for simple myopia.

8.1.2 Topical corticosteroids and corneal wound healing

In chapter 7 it was demonstrated that wound healing following photorefractive keratectomy (PRK) results in a variable degree of loss of corneal transparency (haze) which is highly correlated with regression (loss of the refractive change induced by the surgery). Because of the study design of our first large cohort of patients undergoing PRK, it was evident that the variability in the wound healing response following PRK is reflected in the variability of the final refractive outcome, even between patients within a group all of whom received the same treatment. It is likely that both loss of transparency and regression are related to cellular activity, the synthesis of new collagen and epithelial hyperplasia. The remodelling that occurs as a result of this corneal wound healing activity may limit the potential of PRK as a non-invasive method for correction of myopia and in particular high myopia. There has therefore been considerable interest in the possibility of pharmacological modification of these post-PRK wound healing responses.

Animal studies have shown that topical or systemic corticosteroids can modulate corneal repair after traditional, ie non-excimer, injuries. The tensile strength of healing incisions in rabbit cornea has been shown to be reduced following administration of topical corticosteroids (Newell and Dixon, 1951; Sugar and Chandler, 1974; Phillips et al, 1983;). The suggested mechanism is one of decreased DNA synthesis, as well as less specific 'anti-anabolic effects' which lead to reduced keratocyte activity and therefore decreased collagen synthesis (Polack and Rosen, 1967; Gassett et al, 1969; McDonald et al, 1970). In experimental alkali injuries dexamethasone has been shown to reduce tissue collagenolysis therefore reducing the tendency for perforation (Newsome and Gross, 1977). However, the superficial PRK 'wound' (less than 50 microns in the present study) differs considerably from these experimental injuries and it can not be assumed that topical corticosteroids will have the same effect. An early study using 10.00D excimer laser ablations in 6 rabbits (3 with topical corticosteroids for 10 days and 3 without) suggested that stromal remodelling after PRK might be controlled with these agents Tuft et al, 1989b). The postoperative refractive change was not reported but anterior stromal haze was noted to be virtually absent in the 3 rabbit corneas that received steroids. Because of these considerations, all groups investigating PRK in sighted eyes, up until the time of commencement of this study, used a topical corticosteroid regimen (Gartry et al, 1991b; Seiler et al, 1990b; Seiler et al, 1991; Liu et al, 1990; Zabel et al,

1990; Sher et al, 1991). It has also been suggested that the frequency of administration of these drops can be titrated against the postoperative progress of both the anterior stromal haze and, concomitantly, the rate of regression (Seiler et al, 1990b and 1991). In addition, most series reported relatively small numbers of patients with variation in treatment parameters or corticosteroid regimen (Seiler et al, 1990b and 1991; Liu et al, 1990; Zabel et al, 1990; Sher et al, 1991; Taylor et al, 1989; McDonald et al, 1990b) (see table XIII opposite).

From the results presented in section III (chapters 5 and 6) it has been shown that the excimer laser can be used to improve corneal clarity in a number of superficial pathologies. None of these patients received topical corticosteroids (Gartry et al, 1991a). Similarly, in the blind eye PRK series presented in chapter 7 there was an attempt to produce maximal scarring by use of -7.00D ablations (equivalent to an 'on-axis' ablation depth of 44 microns) without topical corticosteroids (Gartry et al, 1991b and 1992a). Haze was less than in our sighted eye study (Gartry et al, 1992a) although mean age was greater in the blind eye series. Because of Ethics Committee constraints which were based on general considerations in relation to corneal wound healing and the results of the above animal studies, all patients in our original sighted eye cohort were prescribed high dose topical corticosteroids. However, in spite of this, considerable haze, regression and individual variation were reported (Gartry et al, 1991b & 1992a). The haze was first noted at 3 to 4 weeks and reached a maximum at 5 to 6 months. For various reasons, 21 patients defaulted on the corticosteroid regimen and there was no discernible difference, either in haze or regression, between this group and the remainder of the cohort. Since these patients represented a relatively small sub-set and the original sighted eye study had not been designed to evaluate the role of topical corticosteroids it was not possible to carry out a meaningful statistical analysis to establish the significance of these findings. Therefore, because of the limited evidence in support of corticosteroids post-PRK, the individual variation and the likelihood of side-effects with these agents, a prospective, randomised, age-matched, double-blind trial was designed to address the question :

Do topical corticosteroids influence haze or refraction post-PRK?

Table XIII Summary of the literature on PRK at the commencement of the corticosteroid study.

Source, y	No. and Type of Eyes	Follow-up	Corticosteroid Regimen	Treatment Variables	Conclusion
Tuft et al, 1989	6 rabbit	6 mo	3 rabbits treated with subconjunctival betamethasone (4 mg/L) and 0.1% dexamethasone for 10 d	10.00-D ablations, each 3.5 mm in diameter; energy density, 100 mJ/cm ² at 10 Hz	Corticosteroids markedly reduce intensity of anterior stromal haze
Taylor et al, 1989	6 blind	6 mo	2 eyes received subconjunctival steroid and topical prednisolone acetate for 1 mo	Various ablation depths and 4- or 5.2-mm diameters; fluence, 100 mJ/cm ² at 10 Hz	No significant difference in haze when corticosteroids are used
Zabel et al, 1990	6 sighted	24 wk	Corticosteroid ointment used immediately, then 0.1% fluoromethalone for 4 mo	5-12 D; 5-mm ablation zone; fluence, 100 mJ/cm ² at 5 Hz	Good compliance with corticosteroid regimen considered important; no haze reported by 12th wk in 5 patients
McDonald et al, 1990	9 blind	6 mo	None	1.75-9.5 D; 4.5- and 5-mm diameters; fluence, 160 mJ/cm ² at 5 Hz	Minimal haze reported; all corneas virtually clear (0 to 1+ clarity score) at 6 mo
Seiler et al, 1990	10 blind; 13 sighted	6 mo	5 blind eyes (-3.00-D group), no steroids; 5 blind eyes (-5.00-D), variable 0.1% dexamethasone regimen; sighted eyes, variable dexamethasone regimen for 3 mo	Sighted eyes, -2.00- to -7.00-D corrections with 1.00 D overcorrections; fluence, 180 mJ/cm ² at 10 Hz; various diameters up to 3.5 mm	4 of 13 patients within 1 D of expected refraction at 6 mo; subepithelial haze described as temporary, clearing to 0 or +0.5 at 6 mo (with exception of 1 eye with a focal scar)
Seiler et al, 1991	26 sighted	1 y	0.1% Dexamethasone, 5 times per day (first month), then 0.1% prednisolone acetate up to 3 times per day (2 mo), varied with refraction	Preoperative refraction range, -1.40 D to -9.25 D; fluence, 180 mJ/cm ² at 10 Hz; various diameters up to 3.5 mm	24 eyes (92%) within ±1.00 D of intended refraction; noncompliance with steroid regimen described as "risk factor"
Liu et al, 1990	9 blind; 10 partially sighted; 19 sighted	6 mo	Blind eyes as above; sighted eyes, sub-Tenon's steroid after keratectomy; prednisolone acetate drops tapering over 4 wk	1.75- to 11.00-D corrections; fluence, 160 mJ/cm ² at 5 Hz; diameters varied with correction (4.25-5 mm)	All patients combined for purposes of statistical correlations; no conclusion in relation to role of corticosteroids; minimal haze (0 to 1+ at 6 mo)
Gartry et al, 1991	16 blind; 120 sighted	Blind eyes, 22 mo; sighted eyes, mean 1 y (8-18 mo)	Blind eyes (-7.00-D ablations), no corticosteroids; sighted eyes, 0.1% dexamethasone 5 times per day for 2 mo, then reducing doses in 3rd mo (all patients)	2.00- to 7.00-D corrections in whole diopter steps; fluence, 180 mJ/cm ² ; diameter, 4 mm in every case; ablation rate, 0.22 μm per pulse in every case	Considerable individual variation; haze (including some +4 grade) increasing to a maximum at around 6 mo; around 80% of low myopes (<-3.00 D) within ±1.00 D at 6 mo; role of corticosteroids questioned
Sher et al, 1991	31 sighted (from 3 centers)	6 eyes, 1 y (same eyes as above); 24 eyes, 6 mo	0.1% Fluoromethalone every 2 h 1st week, then in reducing doses over 4-5 mo	4.00- to 12.00-D corrections; 5.2- to 6-mm-diameter beam; fluence, 100 mJ/cm ² at 10 Hz (previously reported as 5 Hz and 5 mm in original 6 eyes)	Minimal haze peaking at 3 wk and diminishing over 3-4 mo, not thought to be visually significant; 55% of eyes within ±1.00 D of attempted correction; importance of topical corticosteroids implied

8.2 PATIENT SELECTION AND STUDY DESIGN

Following Ethics Committee approval, prospective patients were sent background information and a questionnaire (see appendix I). The selection criteria are summarised in table XIV opposite. Those patients who were considered suitable were interviewed and a full explanation of the research nature of the trial was given. In keeping with the original sighted eye study design philosophy, to minimise inter-patient variation due to different ablation depths resulting from a variety of attempted corrections we planned to perform only -3.00D and -6.00D treatments (ablation depths 25 and 44 microns respectively). This also allowed investigation of the effects of topical dexamethasone 0.1% at 2 discrete ablation depths. We therefore selected patients with preoperative refraction close to -3.00D (mean = $-2.88D \pm 0.37D$ sd) and -6.00D (mean = $-5.96D \pm 0.53D$ sd). Emmetropia was not therefore the aim in every case. The number of patients in each group required to prove statistical significance for differences in either refraction or haze was calculated using the variance of the data from our original cohort of 120 patients (Gartry et al 1991b & 1992a) :

a. Refraction

Given that the accuracy of subjective refraction is in the order of $\pm 0.50D$ (McGraw et al, 1995), in the -3.00D group we considered that a 1.00D difference between the placebo and steroid group would be regarded as clinically significant and a 2.00D difference in the -6.00D group.

b. Haze

Given the difficulty in assessing haze subjectively we considered that a 1+ difference between groups would be clinically significant. The minimum total sample sizes required therefore (calculated to give the standard 80% chance of detecting a difference at the 5% significance level) were :

n = 36 for the -3.00D group, and n = 50 for the -6.00D group.

Age and Sex.

a. -3.00D group (n = 57) mean age 35.51 yrs, sd 8.1 (range 24 - 58 yrs)

M : F ratio = 23 : 34

b. -6.00D group (n = 56) mean age 39.6 yrs, sd 9.87 (range 24 - 66 yrs)

M : F ratio = 21 : 35

Table XIV Patient selection criteria for the corticosteroid study

Variable	Criterion
Refraction	Myopes with stable refraction close to -3.00D or -6.00D
Astigmatism	Less than 1.00DC
Visual acuity	Best corrected VA > 6/9 in each eye
Age	Greater than 24 yrs
Contact lens history	Contact lens wearers preferred due to likelihood of induced anisometropia (mainly soft lens wearers enrolled); patients with evidence of fluctuating refraction due to corneal distortion excluded
Ophthalmic history	Patients with a history of ocular disease or surgery excluded
Occupation	Individuals with exacting vocational visual requirements excluded (eg pilots, professional drivers)
Motivation	Prospective patients asked for reasons to be included in the study; only those with realistic expectations included

8.2.1 Preoperative assessment

This comprised general ophthalmic examination, subjective refraction, variable contrast visual acuity assessment and ultrasonic axial length measurement. In addition, our system for objective assessment of anterior stromal haze (Lohmann et al, 1991b & 1992) was used in which 2 measurements were recorded : the first was grey-scale disturbance caused by the combined signal of light reflected and light scattered back from the cornea. This signal is comparable to that observed by conventional slit-lamp microscopy. The second was the signal corresponding to back-scattered light alone. This is a measure of degradation of the retinal image and shows correlation with low contrast visual acuity (Lohmann et al, 1991a and 1991b).

The 113 patients recruited into the study were coded and separated into "Steroid" or "Placebo" groups by random, age-matched allocation. The final numbers in each group (data elicited on breaking the code at the end of the trial) were :

- A. -3.00D steroid group n = 29, mean pre-operative refraction = -2.94D
(sd = 0.38D, range -2.125D to -3.625D)
- B. -3.00D placebo group n = 28, mean pre-operative refraction = -2.82D
(sd = 0.36D, range -2.25D to -3.50D)
- C. -6.00D steroid group n = 28, mean pre-operative refraction = -5.90D
(sd = 0.54D, range -5.00D to -7.00D)
- D. -6.00D placebo group n = 28, mean pre-operative refraction = -6.02D
(sd = 0.51D, range -4.75D to -7.00D)

8.2.2 The choice of topical corticosteroid

The coded placebo and steroid preparations were identical in every respect except for the presence or absence of Dexamethasone 0.1%. This steroid was chosen for its proven therapeutic efficacy and ability to penetrate the cornea readily (Cox et al, 1972; Kupferman & Leibowitz, 1974; Leibowitz et al, 1978). In order that neither the patients nor the surgeons could identify the contents of the eyedrop bottles simply by inspection, the 2 preparations had to appear as identical, (clear) solutions. In addition, it was important that the corticosteroid and placebo preparations had identical taste and pH and therefore a buffered solution of the metasulphobenzoate salt of dexamethasone 0.1% was used. Thiomersal 0.005% was present in both placebo and steroid preparations.

8.2.3 The topical corticosteroid regimen

This comprised: 5x per day for 2 months, 4x per day for 2 weeks, 3x per day for 1 week, twice per day for 1 week, once per day for 1 week then discontinued. All patients were counselled at great length regarding the aims of the trial and the importance of good compliance.

8.2.4 The procedure

The Summit Technology UV200 Excimer laser, used throughout these investigations, was used for the steroid study (emission wavelength of 193nm, fixed pulse repetition rate of 10Hz and a radiant exposure of 180mJ/cm² at the cornea). There was no effluent removal and no eye stabilising system. A full description is given in section 2, chapter 4. The laser, which had been serviced immediately prior to the trial, was calibrated at the beginning of each day and printouts were obtained at the beginning, middle and end of each session (to confirm energy output). As many treatment parameters as possible were kept constant including the ablation rate (0.22 microns per pulse) and the maximum beam diameter, which was 4mm as for the previous studies. A detailed consent form was signed prior to the procedure (see appendix I). Patients were then allocated randomly to one of two surgeons (DSG, MGKM) both of whom used a standardised surgical technique as described in chapter 7. Patients were required to fixate a target light within the laser aperture for the duration of the procedure: approximately 10 seconds for the -3.00D group and 17 seconds for -6.00D corrections. To ensure uniformity of treatment, once the laser had been serviced and calibrated accurately, all 113 patients were treated within a 2 week period in July 1991.

8.2.5 Post-operative management / monitoring

Guttae homatropine hydrobromide 2%, guttae cyclopentolate hydrochloride 1%, guttae phenylephrine hydrochloride 10% and oc. chloramphenicol 1% were instilled/applied immediately after the procedure. Analgesics were prescribed, as with the original sighted eye study, and the eye was padded overnight. Administration of the trial drops commenced as soon as the pad was removed and neither the surgeon nor the patient knew which trial drops were being instilled. The study was therefore 'double-blind' or 'double-masked'. Visits were planned for day 1, weeks 1, 2 and 6, months 3, 6, 9 and 12 and annually thereafter. Refraction and slit-lamp examination were performed at each visit.

Intraocular pressure (IOP) was measured at the 2nd and 6th week. Objective assessment of corneal haze and variable contrast visual acuity was carried out in the majority of patients at 6 weeks, 3 months and 6 months.

8.3 RESULTS

From our previous sighted eye studies (Chapter 7) we noted that stabilisation of refraction occurred after 3 to 4 months for the lower degrees of myopia and anterior stromal haze was maximal at 5 to 6 months. We therefore decided to break the code to determine patient assignment after the 6 month visit.

8.3.1 Allergic response

Nine patients (8%) suffered an allergic response to Thiomersal and were therefore excluded from the main cohort. This reaction occurred by the second week in each case and took the form of hyperaemia, watering and lid oedema. On breaking the code all but one of these patients was found to have been using the placebo preparation.

8.3.2 Intraocular pressure (IOP) increase

A significant rise in IOP ($> 5\text{mmHg}$) occurred in 12 patients (11%). In two of these the IOP exceeded 40mmHg . The eyedrops were discontinued therefore and these 2 patients were excluded from the trial. The maximum IOP in the remaining 10 patients, prior to the final month of treatment, was 22mmHg and, as the eyedrops were about to be administered in reducing doses, the regimen was completed as per the protocol. All patients with raised IOP belonged to the steroid groups.

The final number in each group was therefore :

-3.00D : $n=50$ (27 in the steroid group, 23 in the placebo group).

-6.00D : $n=52$ (27 in the steroid group, 25 in the placebo group).

8.3.3 Refractive outcome

The mean change in refraction with time for the -3.00D and -6.00D groups, up to and including the one year visit, is shown in figure 8.1 opposite and table XV (overpage). An initial overcorrection followed by regression to a plateau at around 3 months is common to both groups. In the first 3 months the mean change in refraction for the placebo groups (figure 8.1 a and b, broken line) is consistently less than that of the groups using steroid.

Figure 8.1 Mean change in refraction with time following (a) -3.00D and (b) -6.00D PRK.

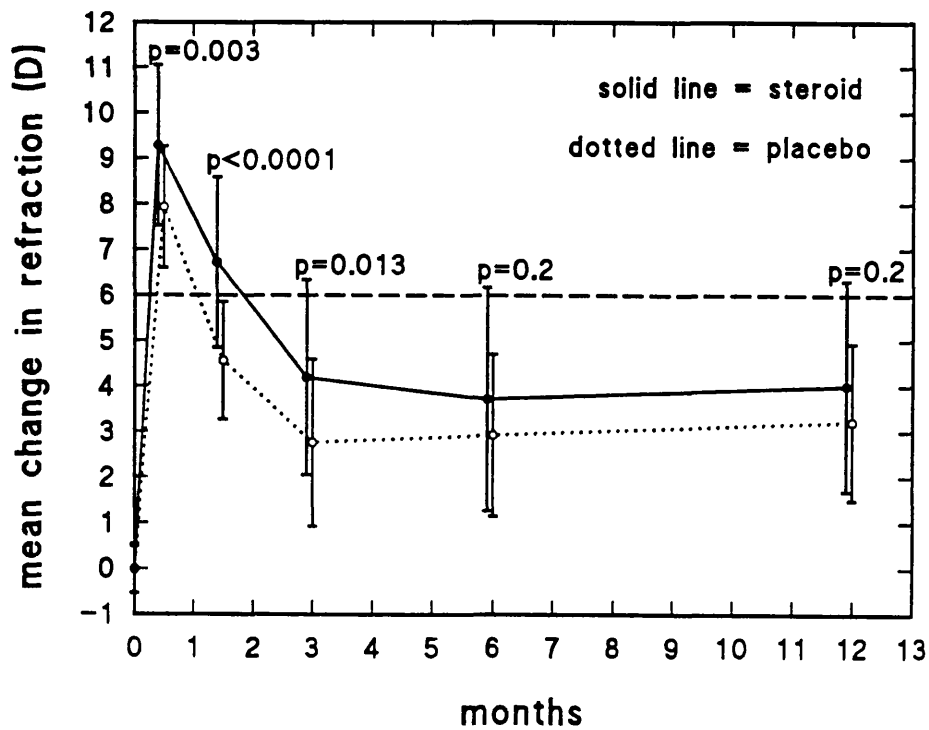
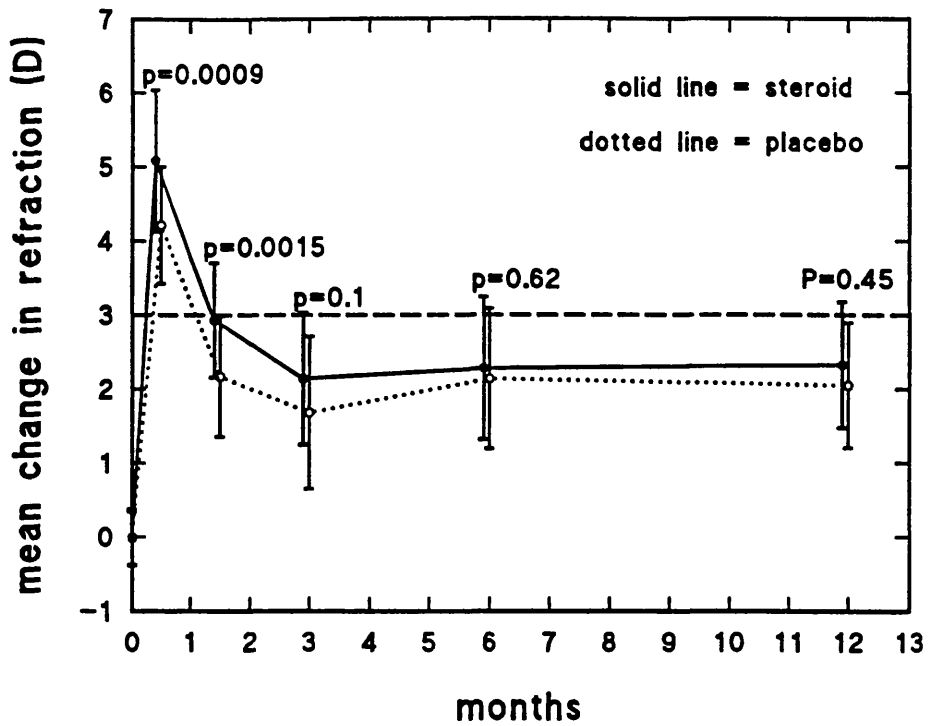

NB Datapoints are displaced slightly in time to facilitate comparison of error bars (± 1 standard deviation). [$p < 0.05$ = a statistically significant difference]

However, by the third month in the -3.00D group there is no statistically significant difference between steroid and placebo ($p=0.1$; 95% confidence interval is -0.10, 1.01). All data were found to be normally distributed therefore 2-tailed Student t-tests used. By the 6th month no significant difference exists in either the -3.00D or -6.00D groups ($p=0.62$ and 0.2 respectively ; 95% confidence intervals are -0.43, 0.71 and -0.43, 2.00 respectively). Similarly, at one year, no significant difference could be demonstrated between the 2 groups in spite of a 0.28D difference between the means in the -3.00D group and a 0.78D difference in the -6.00D group ($p=0.45$ and 0.2 respectively; confidence intervals -0.40, 0.70 and -0.38, 1.96 respectively). There was no statistically significant difference in mean change in refraction between the 3rd, 6th and twelfth months in either group in keeping with the clinical impression that a plateau had been reached (-3.00D steroid, $p=0.58$; -3.00D placebo, $p=0.14$; -6.00D steroid, $p=0.46$; and -6.00D placebo, $p=0.74$). At 6 months the mean correction achieved in the -3.00D group was $2.28 \pm 0.96D$ (steroid) and $2.14 \pm 0.95D$ (placebo) and in the -6.00D group, $3.72 \pm 2.45D$ (steroid) and $2.93 \pm 1.78D$. In order to demonstrate the individual variation encountered all datapoints at one year follow-up are represented in a scattergram (figure 8.2 opposite).

Table XV

Mean change in refraction with time following -3.00D and -6.00D PRK:
Comparison of steroid and placebo groups

Treatment Group	Mean preoperative refraction (D)	Follow-up interval				
		2/52	6/52	3/12	6/12	1 year
-3.00D Placebo	-2.82 (0.36)	4.21 (0.79)	2.17 (0.82)	1.68 (1.03)	2.14 (0.95)	2.05 (0.84)
-3.00D Steroid	-2.94 (0.38)	5.08 (0.95)	2.93 (0.77)	2.14 (0.89)	2.28 (0.96)	2.33 (0.85)
-6.00D Placebo	-6.02 (0.51)	7.93 (1.33)	4.56 (1.29)	2.76 (1.83)	2.93 (1.78)	3.22 (1.72)
-6.00D Steroid	-5.90 (0.54)	9.29 (1.77)	6.72 (1.87)	4.19 (2.14)	3.72 (2.45)	4.00 (2.31)

Values in parentheses are ± 1 standard deviation

Figure 8.2 Scattergram illustrating the considerable individual variation post-PRK.

A wide spread of data points is demonstrated. Some individuals in each group have regressed back to their preoperative level (compare figure 7.7, page 171). Datapoints are displaced slightly in time to facilitate comparison of groups.

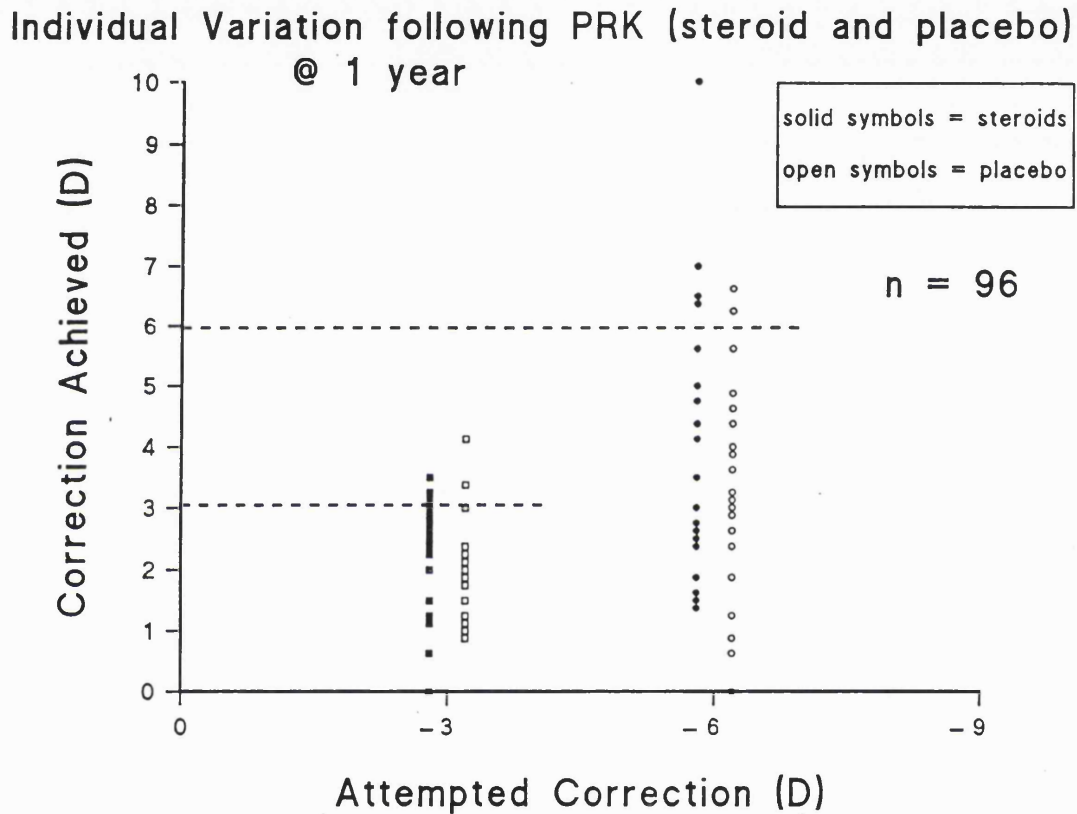

8.3.4 Subjective Anterior Stromal Haze

The time course for the development of anterior stromal haze, as assessed subjectively at the slit-lamp, is shown in figure 8.3 opposite. Haze was found to increase to maximum at around 3 months in the -3.00D groups and 5 to 6 months in the -6.00D groups. There was no statistically significant difference in haze between the steroid and placebo groups at any stage up to and including one year (all p values > 0.05). Beyond 6 months a downward trend is seen for both groups in which anterior stromal haze improves/reduces. The mean subjective slit lamp haze grading at 12 months in the -3.00D group is 0.5 and for the -6.00D group the value is 0.74.

Having used 2 discrete ablation depths (for -3.00D and -6.00D treatments) it is possible also to demonstrate that the amount of haze in the -6.00D group, whether measured subjectively or objectively, was found to be highly statistically significantly greater than that in the -3.00D group (subjectively, steroid $p < 0.001$, placebo $p < 0.002$); objectively, steroid scatter $p < 0.004$, placebo scatter $p < 0.0001$, all at 6 months). There was also a moderately high correlation between subjective haze grading and :

- (a) regression (for the 4 sub-groups, see figure 8.4 overpage) :
-3.00D steroid ($R = -0.71$), -3.00D placebo ($R = -0.53$),
-6.00D steroid ($R = -0.75$), -6.00D placebo ($R = -0.79$), and
- (b) loss of both high (100%) and low (5%) contrast visual acuity using the psychophysical testing techniques previously described (Lohmann et al, 1991a).

8.3.5 Objective Haze Measurement

The results of objective measurement of anterior stromal haze for both reflected and scattered light and scattered light alone are shown in figure 8.5 overpage. In contrast to subjective haze, it would appear that objective haze reaches a maximum at around 3 to 4 months in both the -3.00D and -6.00D groups. There is, however, agreement between objective and subjective assessment of haze in that no statistically significant difference exists between the steroid and placebo groups at any stage. In general, there was only weak inverse correlation of anterior stromal haze with age. The greatest correlation occurred in the -6.00D placebo group ($R = -0.65$). Again in the -6.00D placebo group, a moderate correlation between age and change in refraction seemed to exist ($+0.54$ at 3 months).

Figure 8.3 Mean subjective haze grading with time following:
 (a) -3.00D and (b) -6.00D PRK.

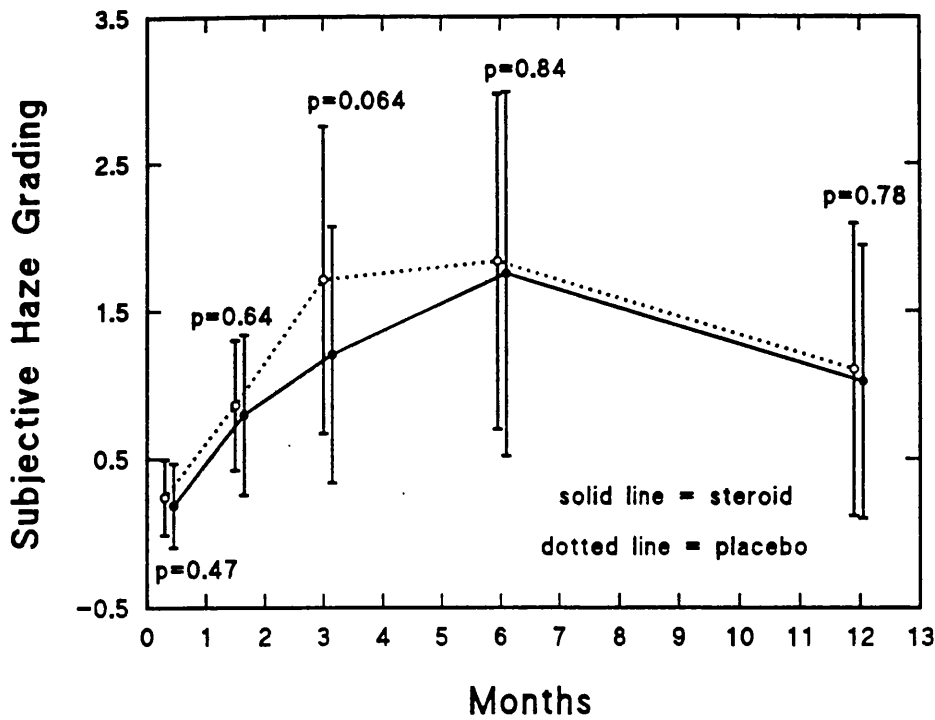
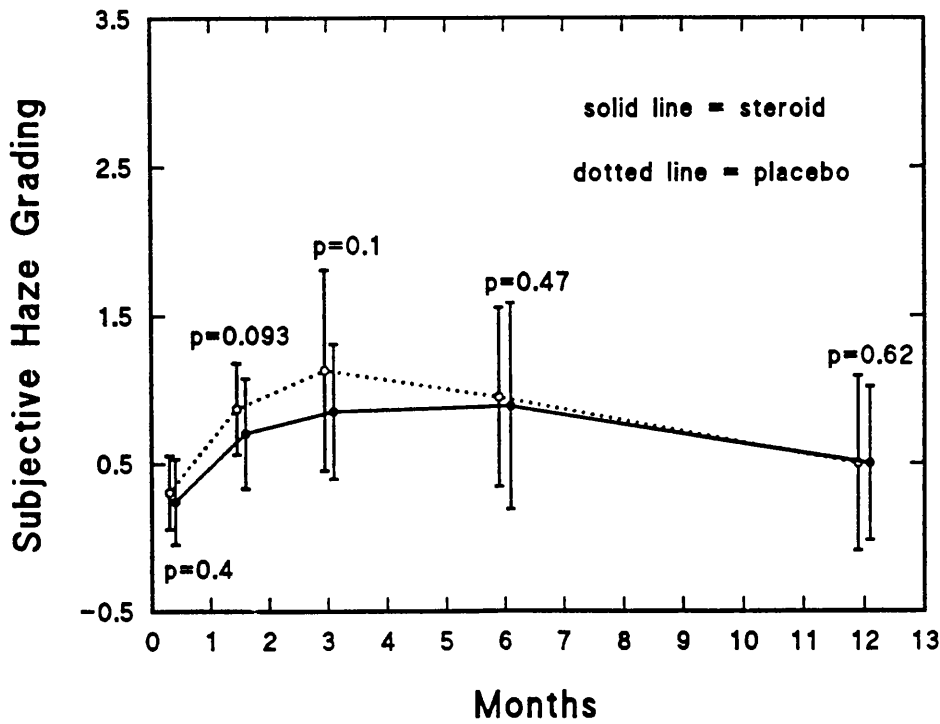

NB Datapoints are displaced slightly in time to facilitate comparison of error bars (± 1 standard deviation). [$p < 0.05$ = a statistically significant difference]

Figure 8.4 Subjective haze versus change in refraction (D) (1/regression) following -6.00D PRK procedures :

(a) with corticosteroid : R = -0.75

(b) with placebo : R = -0.79

Haze versus Regression post -6 PRK (steroid group)

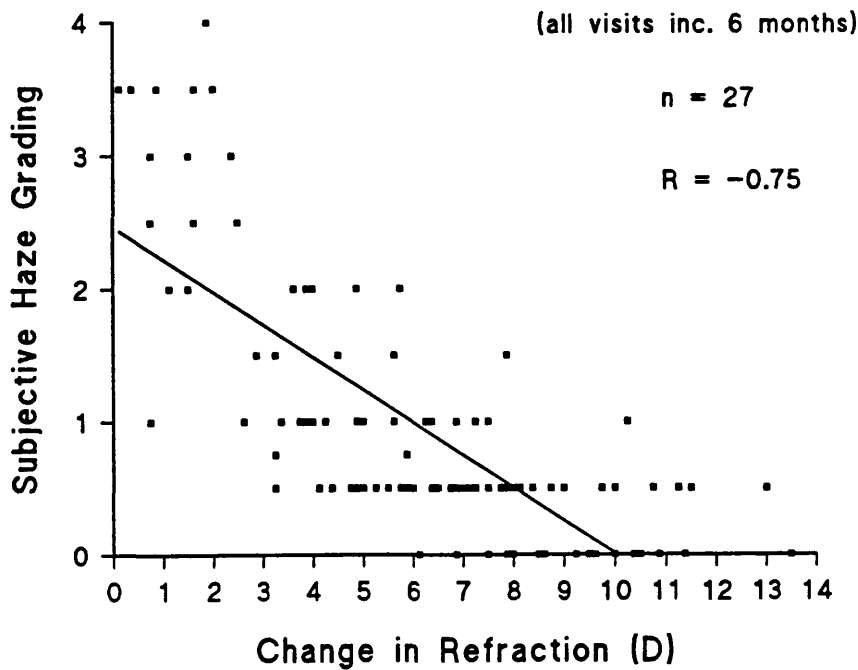

Haze versus Regression post -6 PRK (placebo group)

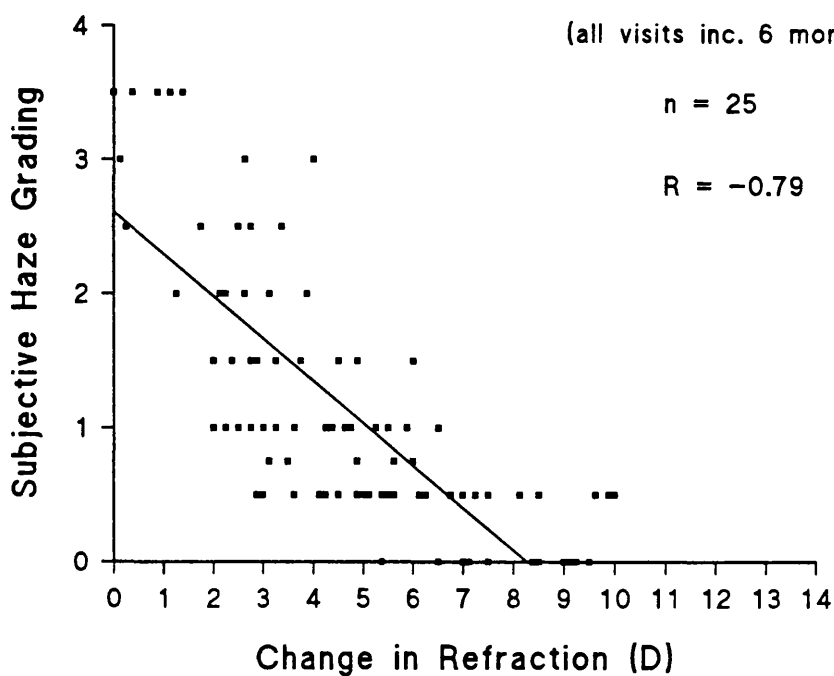
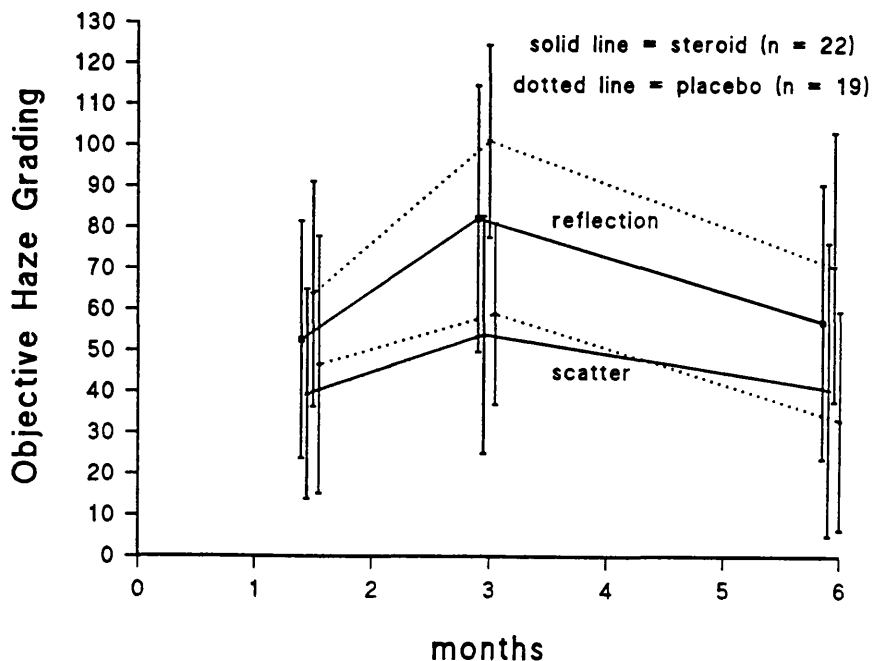
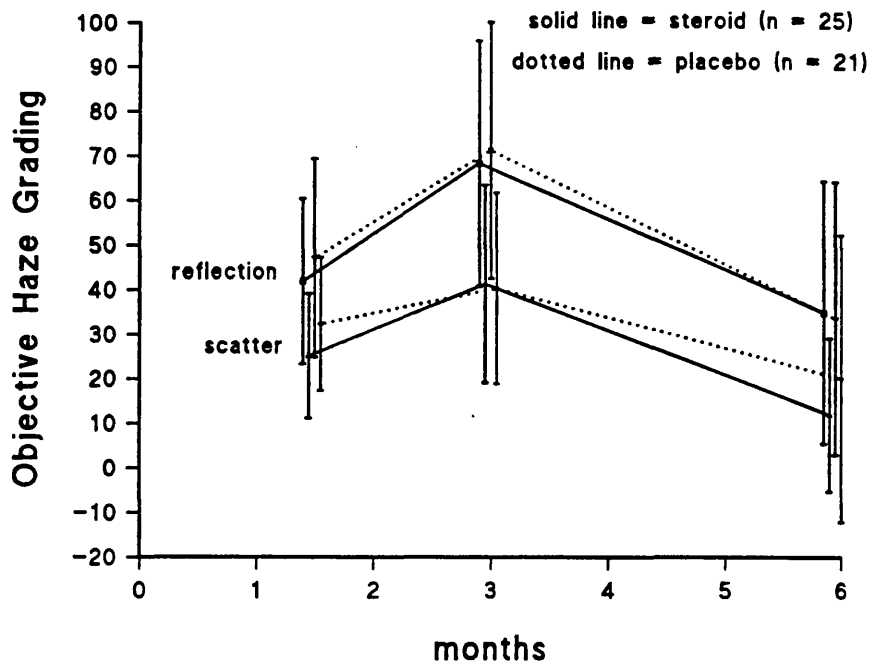

Figure 8.5 Mean objective haze grading with time for both reflected (circles) and scattered (squares) signals following :

(a) -3.00D PRK with corticosteroid (solid line) and placebo (broken line) and

(b) -6.00D PRK with corticosteroid (solid line) and placebo (broken line).



NB Datapoints are displaced slightly in time to facilitate comparison of error bars (± 1 standard deviation). [for p values see text]

8.3.6 The influence of axial length

There was no correlation between axial length and either change in refraction or subjective haze grading.

8.3.7 Complications

These are listed in Table XVI below. The number of patients demonstrating a loss of best spectacle corrected visual acuity in each of the 4 subgroups (-3.00D placebo and steroid, -6.00D placebo and steroid) is small and no significant difference between these groups could be demonstrated in terms of this loss. The change in best spectacle corrected Snellen visual acuity (100% contrast) is shown in figure 8.6 (opposite) for both the 6 and 12 month visits. At 6 months 20% of individuals lost one or more lines of Snellen acuity and one individual had lost 3 lines (anterior stromal haze is maximal at around this stage). Eighteen percent lost 1/2 line while forty one percent remained unchanged. Twenty three percent gained between 1/2 to 1 line, presumably due to increased retinal image size (figure 8.6a). At the one year stage best corrected spectacle acuity had improved in some of those individuals who had experienced a reduction at the 6 month stage. Fifteen percent lost between 1 to 2 lines and no patient lost more than 2 lines. Interestingly, only 6% showed an improvement of 1/2 line and 5% one line (figure 8.6b).

Table XVI Complications of PRK in the corticosteroid study at 12 months (n=96)

Complication	-3.00D PRK		-6.00D PRK		Total % of patients affected
	Steroid	Placebo	Steroid	Placebo	
Reduced BCVA (> 1 line) *	3	4	8	7	15%
Tender to the touch	7	4	4	8	16%
Foreign body sensation	4	5	4	2	12%
Reduced night vision	3	5	3	4	12%
Significant night halo **	2	2	3	5	12%
Epithelial instability	-	1	1	1	3%
Epithelial iron lines	6	8	9	8	32%
Slight ptosis	1	-	-	-	1%
VA reduced in bright light	-	-	1	-	1%

* patients in this category lost between 1 and 2 lines of BCVA

** sufficiently problematic to interfere with night driving

Figure 8.6 Histograms showing change in best corrected visual acuity (all groups) at (a) 6 months and (b) one year.

The vertical broken line represents the point at which there has been no change.

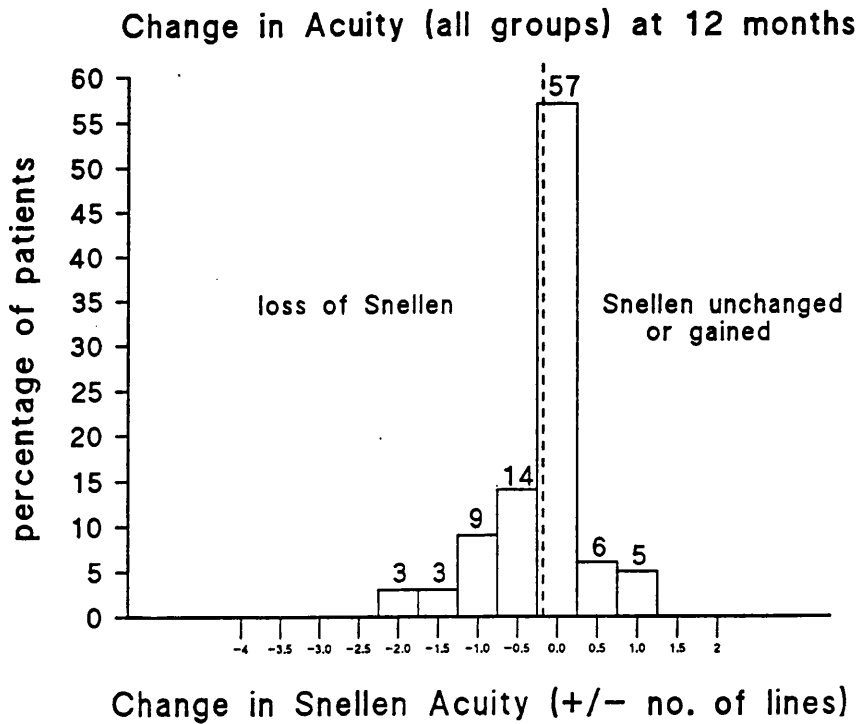
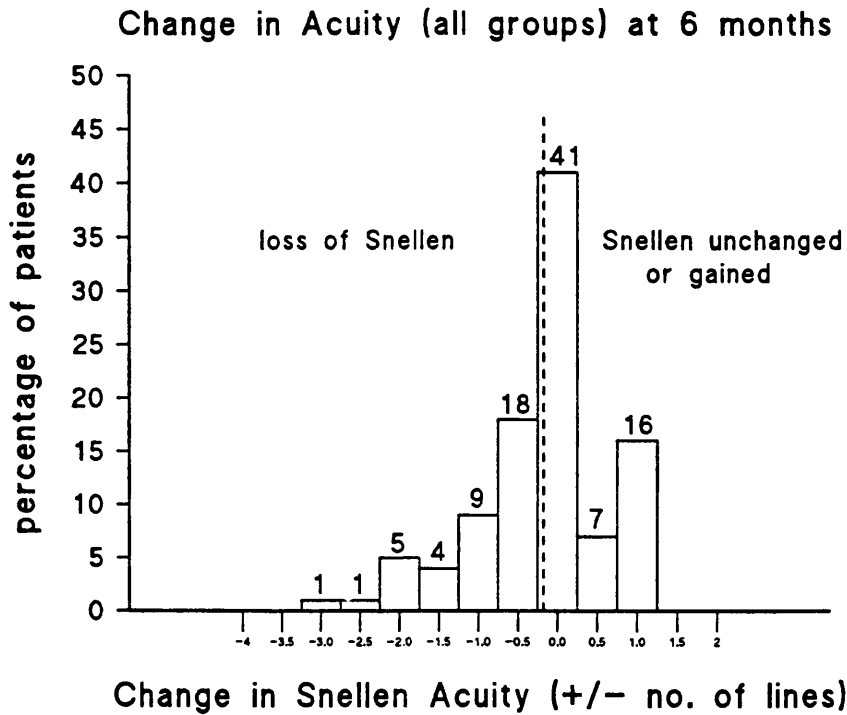

(Snellen acuity is equal to or better than the preoperative level in those patients to the right of the vertical broken line)

8.4 DISCUSSION

The suggestion that wound healing following PRK can be controlled with corticosteroids is based on general principles of corneal wound healing, usually in rabbits, following experimental incisions or chemical wounds (Sugar and Chandler, 1974; Phillips et al, 1983; Newell & Dixon, 1951; Polack and Rosen, 1967; Gassett et al, 1969; McDonald et al, 1970; Newsome and Gross, 1977). However, rabbits are, perhaps, a poor model for the human cornea since they do not possess a Bowman's layer and laboratory rabbits are always relatively young. One PRK animal study suggested that (in 3 rabbits) short-term topical dexamethasone 0.1% four times per day for 10 days reduced cellular activity after wounding and also reduced post-operative corneal haze (Tuft et al, 1989b). Sub-conjunctival betamethasone was also administered at the time of surgery. In corneal disease corticosteroids are often used for their anti-inflammatory effects and can preserve clarity by inhibiting immune reactions, collagen synthesis and neovascularisation (Havener, 1983). Refractive changes have not been observed in these situations. In theory therefore, suppression of cellular activity following PRK would minimise the numbers of new collagen fibres and their resultant altered stereo-spatial relationships which lead to reduced transparency. Inhibition of collagen synthesis would also limit the stromal changes responsible for regression.

8.4.1 Anterior Stromal Haze

On slit-lamp examination, anterior stromal haze was found to increase to a maximum at around 3 months in the -3.00D groups and at between 5 and 6 months in the -6.00D groups (figure 8.3, page 205). No statistically significant difference in haze was demonstrated between the steroid and placebo groups at any stage of follow-up. On objective analysis, although the absolute time course for development of haze differed slightly from that determined subjectively, again no statistically significant difference was found between the corticosteroid and control groups (figure 8.5, page 207). This is in contrast to the animal studies and would suggest that the cellular and extra-cellular components responsible for haze in man are not affected by short-term, high dose dexamethasone.

The amount of anterior stromal haze correlated only relatively poorly with reduction in best spectacle corrected visual acuity (coefficient of correlation, R values at 6 months: -3.00D group, steroid 0.32, placebo 0.006; -6.00D group, steroid 0.016, placebo 0.48).

This is perhaps not surprising since in 2 previous studies using measurement of variable contrast visual acuity only limited disturbances were recorded in the first few weeks at 100% contrast (Lohmann et al, 1991a & 1991b). We have shown previously however that the component of haze generated by scattered light is correlated with loss of low contrast visual acuity (Lohmann et al, 1992). In the present study no difference was demonstrated in loss of low contrast (5%) visual acuity between the steroid and placebo groups although due to large individual variation much larger sample sizes would have been required to demonstrate statistical significance with this test. It is of interest however, that, in spite of the poor correlation between haze and loss of best corrected visual acuity (BCVA), anterior stromal haze showed a significant reduction between 6 and 12 months (figures 8.3 and 8.5) for all groups. Within the same period there was an improvement in those patients who experienced a loss of best corrected visual acuity within the first 6 months. For example, at 6 months one patient, who was in the -6.00D steroid group, had lost 3 lines of BCVA while at the one year stage the deficit had improved, in keeping with the general trend, to one and 1/2 lines. Similarly, no relationship was demonstrated between placebo and steroid in relation to loss of Snellen acuity (high contrast) in agreement with the finding that anterior stromal haze was not influenced by dexamethasone (figure 8.3) However, the number of patients experiencing a loss of Snellen acuity within each of the four sub-groups was relatively small and precludes the application of meaningful confidence limits. It would seem likely that anterior stromal haze is only one contributory factor to the loss of BCVA and hence the poor correlation with either subjective or objective haze and BCVA. It is likely also that a significant contribution to the reduction in BCVA, not apparent on examination at the slit-lamp, is irregular astigmatism. This would certainly be expected to be a greater problem with deeper ablations. In a later study investigating retreatment of patients with significant regression, loss of BCVA was found to be compounded in high myopes and a maximum loss of 4 lines of Snellen acuity was seen in one patient (Gartry et al, 1995).

In contrast to previous laboratory studies in monkeys (Fantes et al, 1990) and data from our original sighted eye cohort (n = 120) (Chapter 7 : Gartry et al, 1991b and 1992a) in this series we have found a highly significant statistical correlation between haze and the depth of the induced ablation ($p < 0.001$) for both subjective and objective assessment of haze. However, in agreement with our previous series (Gartry et al, 1992a) we found moderately good correlation between haze and regression ($R = - 0.75$ on

average (figure 8.4, page 206). When considering other factors, such as age and sex, no consistent correlations were found and care was taken to address these issues in the prospective, randomised design of this trial.

8.4.2 Axial length

From the data presented in chapter 7 it was found that patients with greater degrees of myopia underwent greater regression and developed greater haze than medium myopes undergoing the same correction (Gartry et al, 1991b and 1992a). It was hypothesised therefore that there might be a difference in the quality of collagen and wound repair in higher myopes and that this might be reflected in correlation with axial length (those high myopes with a long eye might regress more compared to those patients with relatively steep corneas). However, there was no relationship between axial length and anterior stromal haze or refractive outcome.

8.4.3 Refractive Outcome

The mean change in refraction was statistically significantly greater in the topical corticosteroid group in the first 3 months after surgery (figure 8.1 and table XV, pages 201 and 202). From this and previous studies, this is the period when overcorrection and subsequent rapid regression occur. It is also the period when most centres prescribe topical corticosteroids (Gartry et al, 1991b & 1992a; Seiler et al, 1990b; Sher et al, 1991).

In the -3.00D group no statistically significant difference in refraction was found beyond (and including) the 3 month stage. In the -6.00D group a statistically significant difference exists up to 3 months but this significance is lost by 6 months. At the one year stage dexamethasone had been discontinued for 9 months and no statistically significant difference between placebo and corticosteroid groups was demonstrated. This would indicate that if corticosteroids have an effect it is only sustained during their administration. The difference between the mean change in refraction comparing steroid with placebo groups at one year is 0.28D (-3.00D group) and 0.78D (-6.00D group). While these differences, particularly in the -6.00D group, would seem to be beneficial they are not statistically significant. If topical corticosteroids can be used to reduce cellular activity (either epithelial hyperplasia or collagen synthesis) then it would be expected that their effects will be maximal in the first few post-operative months when

there is marked stromal remodelling and maximal keratocyte activity. Once this initial healing phase is over it might be expected that beneficial effects from steroid administration would be sustained since in all histopathological studies stromal changes beyond this period are small (Fantes et al, 1990; Hanna et al, 1990; SundarRaj et al, 1990; Marshall et al, 1988). In contrast, any corticosteroid effect after the first 3 months would not be due to large-scale collagen remodelling but might be related to changes in epithelial activity or the water content of the stroma. This may explain clinical observations from other centres using long-term regimens in which patients show rapid and large corticosteroid-dependent swings in refraction even at 6 months. In this and our original PRK study (chapter 7) patients used a fixed regimen for the first 3 months and, in keeping with the protocol, corticosteroid dosage was not titrated against results, and therefore such swings were not detected. Anecdotal reports from centres using flexible corticosteroid regimens in the first 6 post-operative months suggest that regression can be reversed and anterior stromal haze reduced by increasing the dose or reinstating treatment with topical steroids (Seiler et al, 1991; Tengroth et al, 1993). These findings are not at odds with the results of the present study since we have demonstrated a statistically significant beneficial effect on refraction while topical steroids are used in the first few months after PRK.

Topical corticosteroids are associated with potentially serious complications when used over a long period of time (reactivation of Herpes Simplex keratitis, open angle glaucoma, cataract formation and fungal infection) and it is accepted that they should be used only when specifically indicated and under regular supervision by an ophthalmologist (Thygeson, 1977; Spaeth & von Sallman, 1966; Yablonski et al, 1978; Havener, 1983). In view of the relatively high percentage of steroid responders in this and our previous study, which in some cases lead to an IOP in excess of 40mmHg, and the likelihood of other significant side-effects, prolonged use of corticosteroids, in order to maintain the initial beneficial effect on refraction, is unacceptable. Because of possible side effects the present study was not designed to investigate the effect of long-term regular use of topical corticosteroids. It is not possible therefore to comment on the likely outcome had these agents been continued in high doses beyond the 3 month stage. If the statistically beneficial effect seen in the first 3 months could be sustained by continued administration then the problem remains as to how long these potentially harmful agents can be used with impunity. This is of particular relevance in the context of refractive surgery where the eye is, in all other respects, healthy.

It should be noted that the same overall trend to undercorrection with considerable individual variation, as seen in our original cohort (Gartry et al, 1991b & 1992a) was evident in all 4 groups (figure 8.1 and 8.2, pages 201 and 203). In both -3.00D and -6.00D groups (with and without steroids) it can be seen that some patients have regressed to their pre-operative refraction while overcorrection is relatively uncommon (figure 8.2).

8.5 CONCLUSIONS

This study shows that topical corticosteroids have a significant beneficial effect on refraction while used in the first 3 months following excimer laser PRK. However, beyond 3 months, at which time steroids were discontinued, no statistically significant difference in refractive outcome could be demonstrated. Anterior stromal haze was not influenced by the presence or absence of steroids at any stage. It could be hypothesised that the use of high dose topical corticosteroids beyond 3 months may sustain the beneficial effect on refraction and minimize regression but this would be at the expense of the well-known and potentially serious side effects of these agents. We conclude therefore that topical corticosteroids should not be used routinely following photorefractive keratectomy. Studies are continuing to investigate the effects of other agents which may be of use in modulating the wound healing response after this new form of refractive surgery.

SECTION VI

GENERAL DISCUSSION AND CONCLUSIONS

CHAPTER 9

GENERAL DISCUSSION AND CONCLUSIONS

9.1 GENERAL COMMENT

9.1.1 Acceptance of PTK and PRK

During the course of the work described in this thesis the techniques of phototherapeutic keratectomy (PTK) for the treatment of superficial corneal pathology and photorefractive keratectomy (PRK) for the treatment of myopia have developed from the laboratory evaluation phase (chapter 5) through to clinical practice. To date, because of potential long-term problems, the American Food and Drug Administration (FDA) have rightly adopted a cautious approach in their procedures for granting approval for both treatments. Following on from this careful monitoring, in relation to phototherapeutic keratectomy (PTK), approval was granted in March 1995 and the work described in chapters 5 and 6 of this thesis formed part of the information evaluated by the FDA. A rigorous review of safety and efficacy has been applied to PRK by the FDA since (as expressed in chapter 1 page?) the criteria for judging the success of a refractive surgical technique, and particularly one which requires the application of laser radiation, must be stringent. The following quotation embodies these considerations.

"Use of lasers in medicine is governed by two unwritten rules. First, lasers are at their best when there is no conventional treatment for a condition. Second (this rule is a corollary of the first), if there is a good conventional treatment then the onus of proof that the laser is better rests with the user, preferably by means of a randomised controlled trial. Introduction of excimer lasers into clinical practice illustrates these two tenets". (The Lancet, 1991)

Following the recommendation of the FDA Ophthalmic Advisory Panel in October 1994 that PRK should be approved for use in The United States (with 17 restrictions based on the current data) full approval is pending. Again, the results reported in this thesis formed part of the data evaluated by the panel. In addition, The Health Council of the Netherlands reviewed the work presented here prior to publishing a full account of their assessment of PRK in November 1993 (Borst-Eilers et al, 1993).

This chapter attempts to give an overview of our results in relation to work that has taken place around the world, either concurrently or following on from our early studies.

9.2 PRK - A PERSPECTIVE

9.2.1 Current maximum and mean follow-up

The first 'sighted eye' PRK treatments were undertaken at the Free University, Berlin, in August 1989 (Seiler et al, 1991). The first UK 'sighted eye' procedures (described in this thesis) commenced at St Thomas' Hospital in January 1990 (Gartry et al, 1991b and 1992a) at around the same time as those in the USA (McDonald et al, 1991) and at Moorfields Eye Hospital, London, in December 1990 (Ficker et al, 1993). Since then it has been estimated that tens of thousands of patients have been treated worldwide and overall the results have been very encouraging. However, as reported here (chapters 7 and 8), considerable individual variation in response to PRK exists because of differences in wound healing from patient to patient and, in particular, it is much more difficult to treat moderate to high myopia, ie greater than around -6.00 dioptres (Gartry et al, 1991b, 1992a, 1992b, and 1993; Seiler et al, 1994; Sher et al, 1992 and 1994; Tengroth et al, 1993). Over the past 2 years these findings have been confirmed by other centres using different laser systems (Table XVII opposite). The majority of myopes have less than -6.00 dioptres of myopia of course and in these patients predictability and stability of refractive outcome are relatively good (chapter 7). In addition, while there are side effects following PRK (Chapter 7, page 177 and Chapter 8, page 208), few sight-threatening complications have been encountered (Seiler et al, 1994; Maguen et al, 1994, Epstein et al, 1994). It should be emphasized that maximum follow-up at the present time is around only 5 years. Mean follow-up is, therefore, considerably less than this (table XVII) and the procedure should, at the present time, rightly be regarded as investigational. However, from available data, it has been concluded provisionally that serious longer term side-effects such as late-onset, sight-threatening infection, corneal decompensation or permanent, clinically significant scarring, while not impossible, are nevertheless unlikely in low to moderate degrees of myopia (up to around -6.00D, but see below).

Table VXII **EXCIMER LASER PRK FOR MYOPIA - SELECTED SUMMARY OF MAIN PUBLISHED REFRACTION AND VISUAL ACUITY RESULTS**

Author/year	Laser type (beam diameter)	Number of patients	Follow-up	Treatment range (mean) Dioptres D	Refractive outcome (percentage)		No. of lines of BCVA lost (Snellen, %)			Comment
					within +/-1D of intended	unaided vision > 6/12	1	2	> 2	
Seiler et al, 1991	Summit (3.5mm)	26	1 year	-1.40 to -9.25	92% overall	96%	7.7%	Nil	Nil	1 corneal graft needed - slow healing in SLE
Gartry et al, 1991b and 1992a	Summit (4.0mm)	120	1 year to 22/12	-2.00 to -3.00 -4.00 to -5.00 -6.00 to -7.00	83% low * 45% medium 30% high	56% low 49% medium 13% high	15%	3%	Nil	Regression prop. to degree of myopia
Gartry et al, 1992b and 1993	Summit (4.0mm)	113	1 year min.	-3.00 and -6.00 groups	56% 20%	NR	9%	6%	Nil	Steroids of no statistically sig. benefit
Salz et al, 1993	Visx (5.0 and 5.5mm)	12 71 77	2 years 1 year < 1 yr	-1.25 to -7.50	88% low 73% high	93% 79% at 1 year	17%	1.4%	Nil	
Piebenga et al, 1993	Visx (5.0mm)	133	2 years (mean)	-1.25 to -8.37	75% overall	75% overall	8%	Nil	Nil	Role of steroids questioned
Ficker et al, 1993	Summit (4.5 and 5.0mm)	61 81 total	1 year	-1.00 to -10	81% overall	NR	15%	Nil	Nil	Regression prop. to degree of myopia
Taylor et al, 1993	Visx (6mm)	32	6/12	up to -6.00	88% overall	88% overall	25%	19%	Nil	
Seiler et al, 1994	Summit (4.5 and 5.0mm)	126 176	2 year 1 year	-1.25 to ?-10	97.6% low 92% medium 34% high	NR	6%	1%	Nil	Complications intolerable above -6.00D

* For the purposes of comparison between series, 'low' (myopia) is up to -3.00D, 'medium' from -3.10 to -6.00D and 'high' is greater than -6.10D.

** Proceedings papers (no peer review process) NR = not reported

Table XVII **EXCIMER LASER PRK FOR MYOPIA - SELECTED SUMMARY OF MAIN PUBLISHED REFRACTION AND VISUAL ACUITY RESULTS**
(ctd)

Author/year	Laser type (beam diameter)	Number of patients	Follow-up	Treatment range (mean) Diopters D	Refractive outcome (percentage)		No. of lines of BCVA lost (Snellen, %)			Comment
					+/- 1.00D	> 6/12 unaided	1	2	> 2	
Les Jardins et al, 1994**	Meditec (5mm)	63	6/12+	-1.25 to -9.00	91% low 62% medium 41% high	NR	8%	14%	NR	
Kim et al, 1994**	Summit (5.0mm)	45	2 years	-2.00 to -6.00	91.1% overall	NR	4%	NR	NR	"quality" of VA reduced in 22% of patients
Rogers et al, 1994**	Summit (3.6 to 5.0mm)	14	1 year	-10.25 to -20.50	71% overall	NR	50% lost a "variable" amount of BCVA and were retreated			Significant scarring in 50% of patients
Shimizu et al, 1994**	Summit (4.5mm)	11 low 45 med 41 high	1 year	-2.00 to -7.50	100% low 76% medium 44% high	NR	Nil	Nil	Nil	Predictability better in low myopia
Orssaud et al, 1994**	Summit (5.0mm)	176	6/12 mean	-1.00 to -8.50	100% low 86% medium 43% high	NR	8% 18% 73%	9% 38%	NR NR	
Maguen et al, 1994	Visx (? 6.0mm)	240	1 year mean	-1.00 to -7.75	79% overall	89% overall	NR	4-7% at 1 year	NR	1 potentially serious corneal infection.
Epstein et al, 1994 update (see also Tengroth et al)	Summit (4.3 or 4.5mm)	495	2 years min.	-1.25 to -7.50	87.5% overall	91% overall	0.4% only	Nil	Nil	Stabilisation between 18/12 and 2 years
Dutt et al, 1994	Summit (5mm)	35	1 year	-1.50 to -6.10	80% overall	94% overall	Nil at 1 year	Nil	Nil	Loss of BCVA in first 4/12 only

9.3 CURRENT PROBLEM AREAS

There are 5 main areas to consider :

9.3.1 Amount of myopia and regression

As discussed above, the individual variability in corneal wound healing and incidence of complications after PRK increases as greater amounts of myopia are treated. This is demonstrated best when the refraction results are displayed as a scattergram (chapter 7 page 171). Predictability of refractive outcome varies inversely with degree of myopia and is relatively good up to -4.00D and poor beyond -10.00D. In keeping with the nature of wound healing, there is no absolute divide between success and failure but at the -6.00D or -7.00D treatment level there is a 'watershed zone' below which predictability is acceptable but above which predictability becomes progressively worse. Successful results above -9.00D or -10.00D are often quoted in support of PRK for high myopia but, since predictability is poor, they are the exception rather than the rule. Several surgeons who have pioneered the technique of PRK have recommended that, at the present time, the maximum level of correction attempted should be up to around -6.00 or -7.00 dioptres. For example, in a recent update paper which addressed the complications of PRK, it was concluded that :

"Most of the complications such as reduction of glare vision, overcorrection, scarring, and continued regression are strongly dependent on the attempted refractive change. When refractions exceed -6.00D, the incidence of these complications reach, in our opinion, intolerable levels." (Seiler et al, 1994)

As discussed in chapter 7, the mechanism of regression is likely to be twofold, epithelial hyperplasia and anterior stromal remodelling. Figure X opposite demonstrates these 2 elements well.

Figure 9.1

An example of an "aggressive" anterior stromal wound healing response (amounting to a dense, reticulated "scar") 18 months following a -7.00D PRK procedure using a 6mm ablation zone diameter (courtesy of Mr A D McG Steele, FRCS, Moorfields Eye Hospital, London). The histological correlate is seen in a rabbit cornea below (courtesy of Mr S J Tuft, FRCS, Moorfields Eye Hospital). The open arrow indicates the site of the original photoablated surface. It can be seen that not only is there marked epithelial hyperplasia, to approximately double normal thickness, but also deposition of new, disorganised material beneath the epithelium. Both of these factors contribute to regression and individual variation post-PRK.

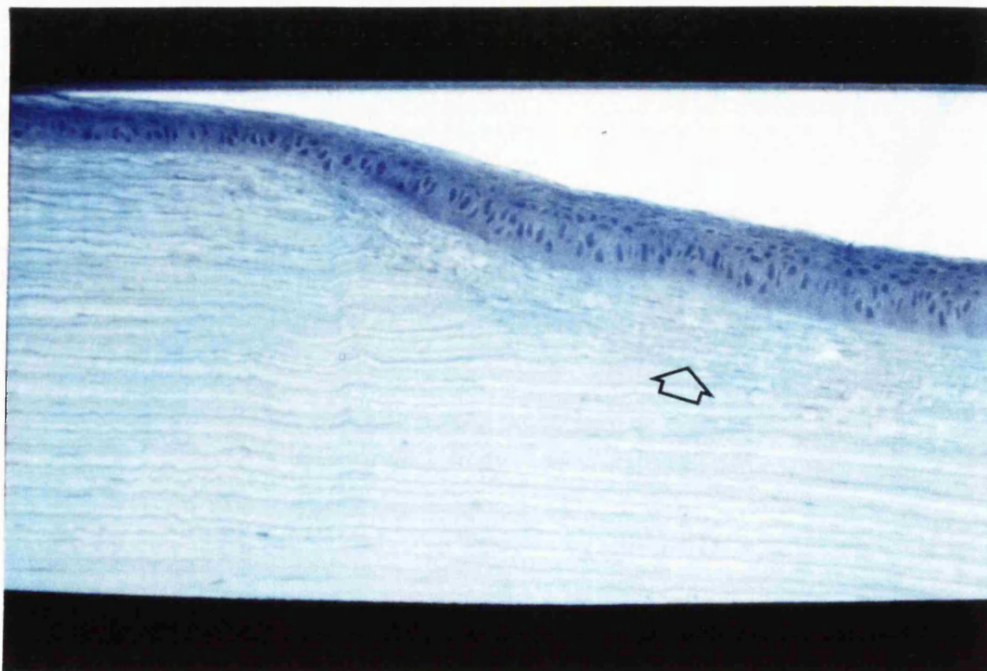
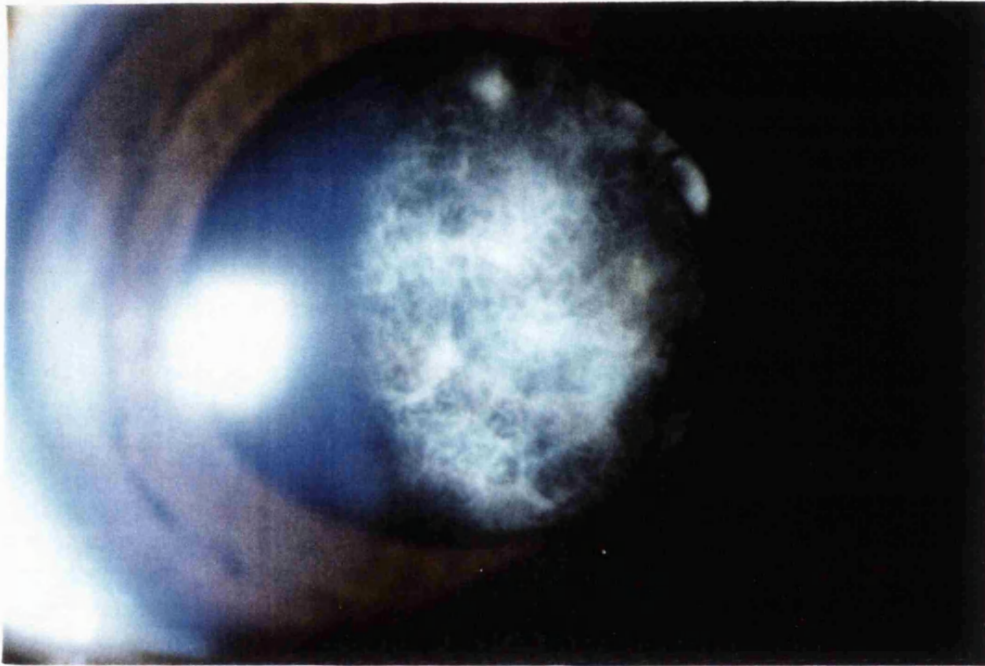

In a questionnaire survey of 182 patients from our 2 early cohorts of patients (chapters 7 and 8) it was found that regression was the major cause of dissatisfaction following PRK (table XVIII opposite and figure 9.2 overpage). It is interesting to note that a successful outcome in the first eye is not always followed by the same result for the second eye. Patients should be made aware therefore that there are no guarantees that both eyes will heal in the same way.

9.3.2 Night halo effects

As stated above - if the surgery is particularly effective a "halo" effect around lights at night may be noted particularly by patients with large pupils. As regression proceeds, this effect decreases during the first few months and is reduced considerably by the use of larger diameter ablation zones where appropriate (O'Brart et al, 1994a).

9.3.3 Corneal haze/scarring

A variable amount of anterior corneal haze, detected on slit-lamp examination, occurs in most patients at around one month post-PRK (see chapter 7, figure 7.8, page 175). This increases up to around the 5 or 6 month stage and then begins to fade. As with other complications, the incidence and severity of this haze increase as higher degrees of myopia are treated.

9.3.4 Loss of best corrected visual acuity (BCVA)

In some patients the period of maximal haze coincides with a significant loss of best corrected visual acuity. It is possible that, due to this haze and/or irregular astigmatism, there may be some permanent deterioration in BCVA in, perhaps, around 15% of the higher myopes treated. One of the patients, a -6.00D myope, in our topical corticosteroid study lost 3 lines of BCVA at the 6 month stage although this 'improved' to a one 1.5 line loss at 1 year. On combining the world literature data from table XVII, around 12.5% of patients lose 1 line of Snellen acuity at one year while around 8% lose 2 lines. Longer term (2 year) studies have shown that best corrected visual acuity improves with time in these patients, particularly between the 6th and 12th months (Gartry et al, 1993).

Table XVIII Patient satisfaction following photorefractive keratectomy after a minimum follow-up of 18 months

Criterion	Number of patients (total = 182)	Percentage of patients
Satisfaction with outcome		
Pleased	154	84%
Indifferent	14	8%
Unhappy	14	8%
Reasons for dissatisfaction		
Regression	24	13%
Haze (reduced visual acuity)	1	1%
Long rehabilitation time	1	1%
Pain of the procedure	1	1%
Overcorrection	1	1%
Should the treatment be freely available?		
Yes	127	70%
No	41	22%
Undecided	14	8%
Second eye to be treated?		
Yes	114	63%
No	37	20%
Undecided	31	17%

Figure 9.2 Patient satisfaction post-PRK based on a questionnaire study (see text for details)

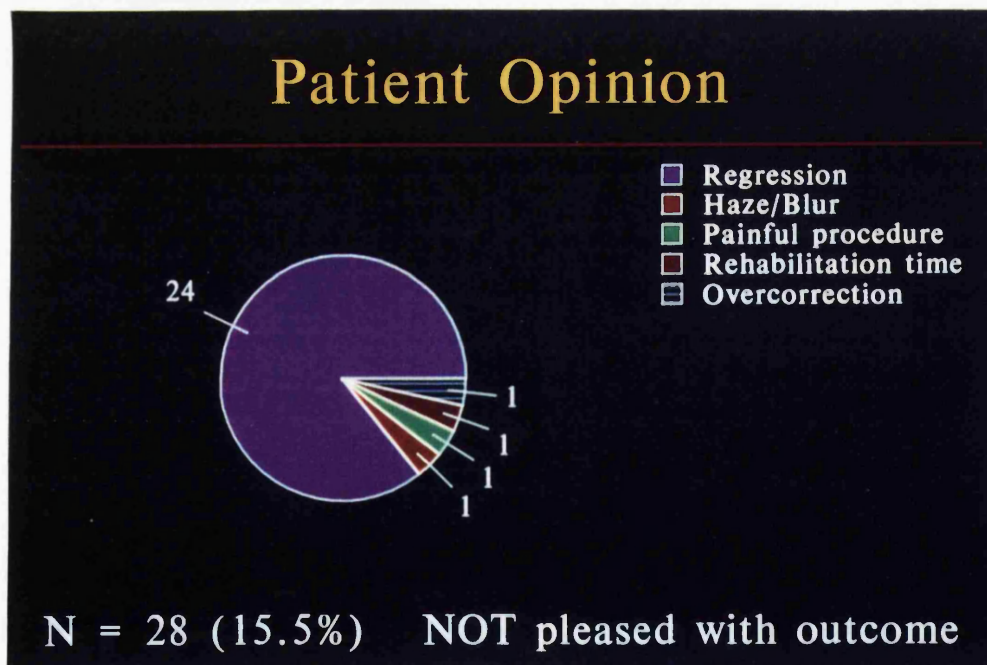
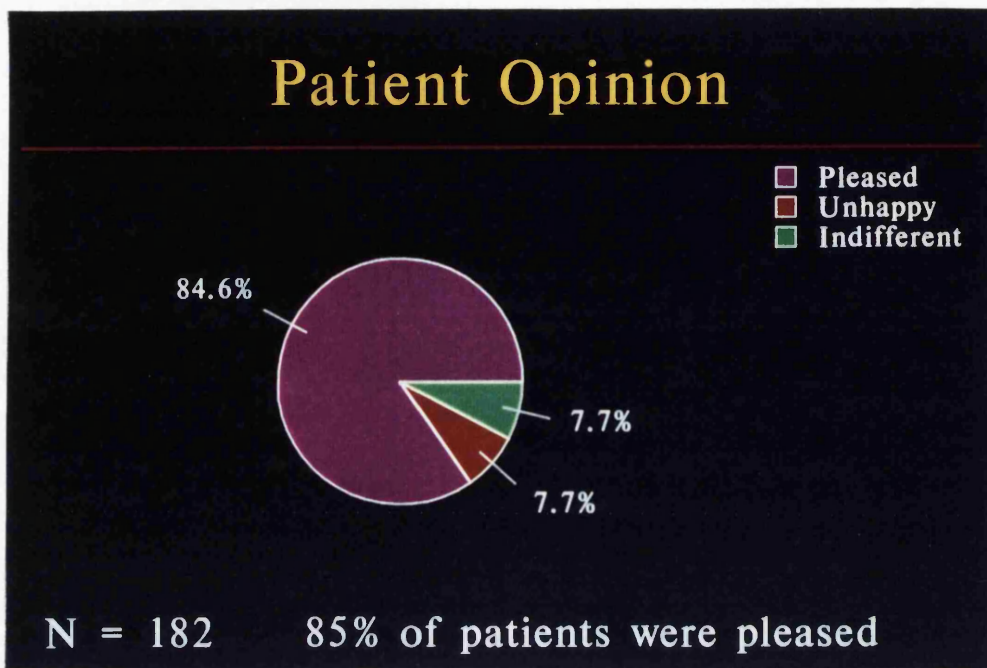

9.3.5 Wound infection and delayed healing

It is of considerable concern that three cases of bacterial keratitis have been reported in the literature, one occurring the day after surgery (Maguen et al, 1994), one 3 days later (McDonald et al, 1990b) and the third, 9 weeks post-PRK, which the authors felt might possibly be associated with long-term topical corticosteroid use (Sampath et al, 1994). In the first 2 cases there was a rapid response to intensive topical antibiotics but in the third case a dense stromal scar resulted in a best corrected visual acuity of counting fingers at 1 metre. In addition, it is well-recognised that excimer laser radiation can reactivate latent herpes simplex virus and that careful history-taking is important therefore (McDonnell et al, 1991; Pepose et al, 1992). While it is often stated that excimer laser radiation at 193nm (far ultraviolet) acts as a sterilising source, it is evident that infection can occur in the early post-operative period while an epithelial defect exists, in spite of instillation of a broad-spectrum antibiotic. It is also of concern that a 62 year old with systemic lupus erythematosus required a penetrating keratoplasty (PK) following delayed epithelial healing which resulted in a non-infectious, perforating corneal ulcer (Seiler et al, 1990) and a second patient needed a PK because of a decentered ablation zone and corneal scarring (Colin, 1992).

9.4 SUMMARY

9.4.1 Results overall

Following on from the early laboratory and clinical studies numerous enthusiastic claims were made in relation to the likely potential of PRK. However, although the laser is indeed capable of removing tissue with great precision, because of the vagaries of corneal wound healing the stage has not yet been reached when a guarantee can be given to a prospective patient that he/she will not need spectacles or contact lenses following the procedure. Our studies have highlighted the considerable **individual variation** post-PRK which can be marked when high degrees of myopia are treated. By definition, this limits predictability. In addition, there are significant complications which must be taken into account (chapters 7 and 8). For example, averaging the results from 12 different research groups around the world (Table XVII) around 15% of patients lose between one and two lines of Snellen acuity, a significant loss, and a further 10% experience significant halos around lights at night which may make night driving difficult. Other less troublesome complications include an intermittent foreign body sensation on waking and tenderness

when rubbing the eye. Nevertheless, patient satisfaction has been high and around 85% of patients say they are pleased that they underwent PRK (Table XVIII and figure 9.2). This percentage could be increased further with careful patient selection according to the guidelines suggested in appendix II. The only useful predictor of regression (the chief cause of dissatisfaction) that has been identified to date is the amount of preexisting myopia although there is a weak correlation also with age in that older patients tend to regress less and therefore may remain overcorrected - a situation to be avoided if at all possible. Again, on averaging results from the published studies in Table XVII, approximately 88% of patients up to -3.00D can expect to be within +/- 1D of emmetropia while around 72% of those between -3.10 and -6.00D, and 41% of those between -6.10 and -9.00D will be within these limits. In addition, around 70% of the higher myopes benefit by having their myopia reduced by at least half, albeit with the greater risk of complications. These patients with partial correction are usually pleased since they benefit from considerable improvement in their unaided vision and less absolute dependence on spectacles or contact lenses. In addition, they benefit from the improved cosmesis which results from being able to use thinner spectacle lenses.

9.4.2 Current and future developments

It is evident that predictability of refractive outcome depends upon individual wound healing characteristics. Our prospective, randomised and double-masked topical corticosteroid study was designed to investigate the role that these agents might have in the modulation of the wound healing response following PRK (chapter 8). While we found a statistically beneficial effect on refraction while these agents were used, upon cessation of the corticosteroids the effect became statistically insignificant. These results have been confirmed subsequently by other investigators by prospective studies (Piebenga et al, 1993; O'Brart et al, 1994b). The wound healing mechanisms within the anterior corneal stroma are complex and it is unlikely that any single topical agent will prove of benefit in modulating the response to PRK. However it can be hypothesised that a subgroup of patients exists characterised by their relatively 'aggressive' wound healing response and that it might be possible in future to identify these individuals prior to the treatment. Specific medical or surgical interventions might then be possible.

With the introduction of larger ablation diameters predictability has improved (Taylor et al, 1993; O'Brart et al, 1994a) and it is now known that different ablation diameters

produce different effects on the post-PRK corneal epithelium with a relatively small diameter zone (4 or 5mm) being characterised by epithelial hyperplasia. This is much less evident with 6mm zones (Gauthier et al, 1995). In addition, it is possible that accurate centration of the ablation zone, made possible by sophisticated eye tracking systems, will produce exceptionally smooth surfaces and improve predictability further. However, even if the ideal ablation zone profile, diameter and surface characteristics were available, (assuming that they could be defined), within the corneal biological system there is still likely to be some variation around the mean refractive outcome. It is presently of great interest therefore that, in relation to high myopia, in which haze, regression and loss of BCVA are more common, it is now known that an **intrastromal** ablation prevents the interaction between the healing epithelium and the exposed, newly-ablated surface. Preliminary reports suggest that these techniques show considerable promise with greater predictability and less stromal haze.

9.4.3 Conclusion

Such has been the interest in excimer laser refractive surgery over the past 5 years that continued efforts to improve the results can be expected to produce better (or perhaps entirely different) lasers and greater knowledge of mechanical or pharmacological manipulation of the corneal wound healing response. In any event, while for lower degrees of myopia PRK would seem to be relatively predictable and safe, it is of vital importance that patients are made aware of the limitations of photorefractive keratectomy in order that they might make a fully informed decision.

"Critical caution, not unrestrained enthusiasm, should characterize the assessment of refractive surgical techniques." (Waring, 1992b)

SECTION VII

REFERENCES AND APPENDICES

REFERENCES

- Andrew JE, Dyer PE, Forster D, Key PM 1983 Direct etching of polymeric materials using XeCl laser. *Appl Phys Letts* 43:717-719
- Barraquer JI 1964 Keratomileusis for the correction of myopia. *Arch Soc Am Oftal Optom* 5:27-48
- Bende T, Seiler T, Schilling A, Wollensak J 1988 Reproduzierbarkeit von Exzisionstiefen bei der Laser-Hornhautchirurgie. *Laser in der Ophthalmologie* (Ed: Wollensak J), ENKE Verlag, Stuttgart, p.148-152.
- Beckman H, Rota A, Barraco R 1971 Limbectomies, keratectomies and keratotomies performed with a rapid pulsed carbon dioxide laser. *Am J Ophthalmol* 71:1277-1283
- Berlin MS, Martinez M, Papaioannou T, Grundfest W, Goldenberg T, Laudenslager J 1988 Goniophotablation : Excimer laser glaucoma filtering surgery. *Lasers Light Ophthalmol* 2:17-24
- Binder PS, Waring GO, Arrowsmith PN, Wang CL 1988 Traumatic rupture of the cornea after radial keratotomy. *Arch Ophthalmol* 106:1584-1590
- Bores LD, Myers W, Cowden J 1981 Radial keratotomy : An analysis of the American experience. *Ann Ophthalmol* 13:941-948
- Borst-Eilers E 1993 Health Council of the Netherlands: Standing Committee on Medicine. Lasers in sight. Laser correction of refractive errors. Publication no. 1993/19E
- Colin J 1992 Greffes de cornee apres keratectomie photorefractive au laser excimer. *J Fr Ophtalmol* 15:437

- Costagliola C, Balestrieri P, Fioretti F, et al 1994 ArF 193nm excimer laser corneal surgery as a possible risk factor in cataractogenesis. *Exp Eye Res* **58**:453-457
- Cotliar AM, Schubert HD, Mandel ER, Trokel SL 1985 Excimer laser radial keratotomy. *Ophthalmology* **92**:206-208
- Cox WV, Kupferman A, Leibowitz HM 1972 Topically applied steroids in corneal disease : II. The role of drug vehicle in stromal absorption of dexamethasone. *Arch Ophthalmol* **88**:549-552
- Dehm EJ, Puliafito CA, Adler CM, Steinert RF. 1986 Corneal endothelial injury in rabbits following excimer laser ablation at 193nm and 248nm. *Arch Ophthalmol* **104**:1364-1368
- Del Pero RA, Gigstad JE, Roberts AD, et al 1990 A refractive and histopathological study of excimer laser keratectomy in primates. *Am J Ophthalmol* **109**:419-429
- Deutsch TK, Geis MW 1983 Self-developing UV photoresist using excimer laser exposure. *J Appl Phys* **54**:7201-7204
- Driver and Vehicle Licensing Agency (DVLA) 1993 At a glance guide to the current medical standards of fitness to drive. HMSO, London, p.19.
- Dutt S, Steinert RF, Raizman MB, Puliafito CA 1994 One Year Results of Excimer Laser Photorefractive Keratectomy for Low to Moderate Myopia. *Arch Ophthalmol* **112**:1427-1436
- Dyer PE, Srinivasan R 1986 Nanosecond photoacoustic studies on ultraviolet laser ablation of organic polymers. *Appl Phys Lett* **48**:445-447
- Epstein D, Fagerholm P, Hamberg-Nystrom H, Tengroth B 1994 Twenty four month follow-up of Excimer laser photorefractive keratectomy for myopia. *Ophthalmology* **101**:1558-1564

- Fantes EF, Hanna KD, Waring GO, Pouliquen Y, Thompson KP, Salvodelli M 1990 Wound Healing after excimer laser keratomileusis (photorefractive keratectomy) in monkeys. *Arch Ophthalmol* **108**:665-675
- Ficker LA, Bates AK, Steele ADMcG, et al 1993 Excimer Laser Photorefractive keratectomy for myopia : 12 month follow-up. *Eye* **7**:617-624
- Fine BS, Fine S, Peacock GR, Geeraets WJ, Klein E 1967 Preliminary observations on ocular effects of high power, continuous CO₂ laser irradiation. *Am J Ophthalmol* **64**:209-222
- Forstot SL, Damiano RE 1988 Trauma after radial keratotomy. *Ophthalmology* **95**:833-835
- Fyodorov SN, Durnev VV 1979 Operation of dosaged dissection of corneal circular ligament in cases of myopia of mild degree. *Ann Ophthalmol* **11**:1185-1190
- Garrison B J, Srinivasan R 1985 Laser ablation of organic polymers: microscopic models for photochemical and thermal processes. *J Appl Phys* **57**:2909-2914
- Gartry DS, Kerr Muir MG, Marshall J 1991a Excimer laser treatment of corneal surface pathology : A laboratory and clinical study. *Br J Ophthalmol* **75**:258-269
- Gartry DS, Kerr Muir MG, Marshall J 1991b Photorefractive keratectomy with an Argon Fluoride Excimer Laser: A Clinical Study. *Refract Corneal Surg* **7**:420-435
- Gartry DS, Kerr Muir MG, Marshall J 1992a Excimer Laser Photorefractive keratectomy - 18 month follow-up. *Ophthalmology* **99**:1209-1219
- Gartry DS, Kerr Muir MG, Lohmann CP, Marshall J 1992b The effect of topical corticosteroids on refractive outcome and corneal haze after photorefractive keratectomy. *Arch Ophthalmol* **110**:944-52

- Gartry DS, Kerr Muir MG, Marshall J 1993 The effect of topical corticosteroids on refraction and corneal haze following excimer laser treatment of myopia : an update. A prospective, randomised, double-masked study. *Eye* 7:584-590
- Gartry DS 1995a Patient selection guidelines for photorefractive keratectomy (PRK)
The British College of Optometrists - patient and practitioner guidelines
- Gartry DS 1995b Excimer laser treatment of myopia - the present position
(Fortnightly Review) *Br Med Journal* 310:979-985
- Gartry DS 1995c Treatment of myopia with the excimer laser - is it really the bottom line? *Ophthal Physiol Opt* 15(Suppl 1):S2-S10
- Gartry DS, Larkin DFP, Flaxel CJ, Ficker LA, Steele ADMcG Retreatment for significant regression following excimer laser photorefractive keratectomy (PRK) - a randomised, double-masked trial. *Invest Ophthalmol Vis Sci* 36:S190
- Gassett P R, Lorenzetti D W C, Ellison E M, Kaufman H E 1969 Quantitative corticosteroid effect on corneal wound healing. *Arch Ophthalmol* 81:589-591
- Gauthier C, Epstein D, Holden BA, et al 1995 Epithelial alterations following photorefractive keratectomy for myopia. *J Refract Surg* 11:113-118
- Gebhardt BM, Salmeron B, McDonald MB 1990 The effect of excimer laser energy on the growth potential of corneal keratocytes. *Cornea* 9:205-210
- Gelender H, Gelber HC 1983 Cataract following radial keratotomy. *Arch Ophthalmol* 101:1229-1231
- Gelender H, Flynn HW, Mandelbaum SH 1982 Bacterial endophthalmitis resulting from radial keratotomy. *Am J Ophthalmol* 93:323-326

- Green H, Bold J, Parrish JA, Kochever IE, Oseroff AR 1987a Cytotoxicity and mutagenicity of low intensity, 248 and 193nm excimer laser radiation in the mammalian cell. *Cancer Research* 47:410-413
- Green H, Margolis R, Boll J, Kochevar IE, Parrish JA, Oseroff JR 1987b Unscheduled DNA synthesis in in human skin after in vitro ultraviolet excimer laser ablation. *J Invest Dermatol* 89:201-204
- Hanna KD, Pouliquen YM, Salvodelli M, et al 1990 Corneal wound healing in monkeys 18 months after excimer laser photorefractive keratectomy. *Refractive and Corneal Surgery* 6:340-345
- Havener WH 1983 *Ocular Pharmacology*, 5th edition. CV Mosby, St Louis, Missouri
- Hecht J 1983 Excimer laser update. *Lasers applications* 12:43-48
- Holladay JT, Lynn MJ, Waring GO, Gemmill M, Keehn GC, Fielding B 1991 The relationship of visual acuity, refractive error and pupil size after radial keratotomy. *Arch Ophthalmol* 109:70-76
- Keates RH, Pedrotti L, Weichel H, Possel WH 1981 Carbon dioxide laser beam control for corneal surgery *Ophthalmic Surg* 12:117-122
- Kerr Muir MG, Trokel SL, Marshall J, Rothery S 1987 Ultrastructural comparison of conventional surgical and Argon Fluoride excimer laser keratectomy. *Am J Ophthalmol* 103:448-453
- Kim YJ, Sohn J, Tchah H, Lee C 1994 Photoastigmatic refractive keratectomy in 168 eyes : 6 month results. *J Cataract Refract Surg* 20:387-391
- Kim JH, Hahn TW, Lee CY, Sah WJ 1994 Excimer laser photorefractive keratectomy for myopia : 2 year follow-up. *J Cataract Refract Surg (Suppl)* 20:229-233

- Kochever IE 1989 Cytotoxicity and mutagenicity of excimer laser radiation.
Lasers in Surg Medicine 9:440-444
- Kochever IE, Walsh AA, Green HA, Sherwood M, Shih MG, Sutherland BM 1991
DNA damage induced by 193nm radiation in mammalian cells. Cancer Research
51:288-293
- Kremer FB, Marks RG 1983 Radial keratotomy : Prospective evaluation of safety and
efficacy. Ophthalmic Surgery 14:925-930
- Kriegerowski M, Bende T, Seiler T 1990 Do eye drops influence ablation rate during
laser keratomileusis? Invest Ophthalmol Vis Sci 31(Suppl):478
- Krueger RR, Trokel SL 1985 Quantitation of corneal ablation by ultraviolet laser light.
Arch Ophthalmol 103:1741-1742
- Kupferman A, Leibowitz HM 1974 Topically applied steroids in corneal disease : V
Dexamethasone alcohol. Arch Ophthalmol 92:329-330
- Lancet (editorial, anon) 1991 Excimer laser 1991. The Lancet 338:83
- Landry RJ, Pettit GH, Hahn DW, Ediger MN, Yang GC 1994 Preliminary evidence
of free radical formation during argon fluoride excimer laser irradiation of corneal
tissue. Lasers and Light in Ophthalmology 6:87-90
- Leahey AB, Burkholder TO. 1994 Infectious keratitis 1 day after radial keratotomy.
Arch Ophthalmol 112:1512-1513
- Leibowitz HM, Stewart RH, Kupferman A, Kimbrough RL 1978 Evaluation of
dexamethasone acetate as a topical ophthalmic formulation. Am J Ophthalmol
86:418-423

- Leidenix MJ, Lundergan MK, Pfister D, Kastl PR, Smith RE, Mamalis N 1994 Perforated bacterial corneal ulcer in a radial keratotomy incision secondary to minor trauma. *Arch Ophthalmol* **112**:1513-1514
- Les Jardins SL, Auclin F, Roman S, Burtschy B, Les Jardins JL 1994 Results of photorefractive keratectomy on 63 myopic eyes with six months minimum follow-up. *J Cataract Refract Surg (Suppl)* **20**:223-228
- L'Esperance F 1989 Chapter 23: Excimer laser In: L'Esperance F (ed) *Ophthalmic Lasers (3rd Edition)*. CV Mosby, St Louis, p.887-918
- Lindquist TD, Rubinstein JB, Hoffman RF, Lindstrom RL 1986 Astigmatic keratotomy. In: Sanders DR (ed) *Radial keratotomy surgical techniques*. Slack Inc. Thorofare, NJ, p.115-130
- Lindstrom RL 1990 Surgical correction of astigmatism: a clinician's perspective. *Refract Corneal Surg* **6**:437-454
- Lipschitz I, Loewenstein A, Lazar M. 1994 Comparison of excimer laser treatment of astigmatism and myopia (letter) *Arch Ophthalmol* **112**:1510-1511
- Liu JC, McDonald MB, Varnell R, Andrade HA 1990 Myopic excimer laser photorefractive keratectomy: An analysis of clinical correlations. *Refract Corneal Surg* **6**:321-328
- Loertscher H, Mandelbaum S, Parrish RK, Parel JM 1986 Preliminary report on corneal incisions created by a hydrogen fluoride laser. *Am J Ophthalmol* **102**:217-221
- Lohmann C, Gartry DS, Kerr Muir MG, Timberlake GT, Marshall J 1991a "Haze" in photorefractive keratectomy : Origins and consequences. A review. *Lasers and Light in Ophthalmol* **4**:15-34

- Lohmann C, Fitzke F, Timberlake G, Gartry DS, Kerr Muir MG, Marshall J 1991b
Corneal haze after excimer laser refractive surgery: Objective measurements and functional implications. *Europ J Ophthalmol* 1:173-180
- Lohmann C, Fitzke F, Timberlake G, Gartry DS, Kerr Muir MG, Marshall J 1992
Corneal transparency after excimer laser photo-refractive keratectomy : a new technique for objective measurements of haze. *Refract Corneal Surg* 8:114-121
- Machat JJ, Tayfour F 1993 Photorefractive keratectomy for myopia : Preliminary results in 147 eyes. *Ref Corneal Surg (Suppl)* 1993;9:S16-S19
- Macrae S, Rich L, Phillips D, Bedrossian R 1989 Diurnal variation in vision after radial keratotomy. *Am J Ophthalmol* 107:262-267
- Maguen E, Salz JJ, Nesburn AB, Warren C, Macy JJ, Papaioannou T, et al 1994
Results of Excimer laser photorefractive keratectomy for the correction of myopia. *Ophthalmology* 101:1548-1557
- Malley DS, Steinert RF, Puliafito CA, Dobi E 1990 Immunofluorescence study of corneal wound healing after excimer laser anterior keratectomy in the monkey eye. *Arch Ophthalmol* 108:1316-1322
- Marshall J 1988 Lasers in ophthalmology : The basic principles. *Eye* 2:Suppl S98-S112
- Marshall J, Trokel S, Rothery S, Schubert H 1985 An ultrastructural study of corneal incisions induced by an excimer laser at 193nm. *Ophthalmology* 92:749-758
- Marshall J, Trokel S, Rothery S, Krueger RR 1986a A comparative study of corneal incisions induced by diamond and steel knives and two ultraviolet radiations from an excimer laser. *Br J Ophthalmol* 70:482-501
- Marshall J, Trokel S, Rothery S, Krueger RR 1986b Photoablative reprofiling of the cornea using an excimer laser : Photorefractive keratectomy. *Lasers in Ophthalmol* 1:21-48

- Marshall J, Trokel S, Rothery S, Krueger RR 1988 Long-term healing of the central cornea after photorefractive keratectomy using an excimer laser. *Ophthalmology* 95:1411-1421
- McDonald MB, Kaufman HE, Aquavella JV, et al 1987a The nationwide study of epikeratophakia for aphakia in adults. *Am J Ophthalmol* 103:358-365
- McDonald MB, Kaufman HE, Aquavella JV, et al 1987b The nationwide study of epikeratophakia for myopia. *Am J Ophthalmol* 103:375-383
- McDonald MB, Frantz JM, Klyce SD, et al 1990a One year refractive results of central photorefractive keratectomy for myopia in the non-human primate cornea. *Arch Ophthalmol* 108:40-47
- McDonald MB, Frantz M, Klyce SD, et al 1990b Central photorefractive keratectomy for myopia : The blind eye study. *Arch Ophthalmol* 108:799-808
- McDonald MB, Liu JC, Byrd TJ, et al 1991 Central photorefractive keratectomy for myopia. *Ophthalmology* 98:1327-37
- McDonald TO, Borgmann AR, Roberts MD, Fox LG 1970 Corneal wound healing :
1. Inhibition of stromal healing by three dexamethasone derivatives. *Invest Ophthalmol* 9:703-711
- McDonnell PJ, Lean JS, Schanzlin DJ 1987 Globe rupture from blunt trauma following hexagonal keratotomy. *Am J Ophthalmol* 103:241-242
- McDonnell PJ, Moreira H, Clapham TN, et al 1991 Photorefractive keratectomy for astigmatism. Initial clinical results. *Arch Ophthalmol* 109:1370-1373
- McGraw P, Winn B, Whitaker D 1995 Reliability of the Snellen chart. *Br Med Journal* 310:1481-1482

- Muller-Stolzenburg NW, Muller GJ, Buchwald HJ, et al 1990 UV exposure of the lens during 193nm excimer laser corneal surgery. *Arch Ophthalmol* **108**:915-916
- Munnerlyn CR, Koons SJ, Marshall J 1988 Photorefractive keratectomy : A technique for laser refractive surgery. *J Cataract Ref Surg* **14**:46-52
- Newell FW, Dixon JM 1951 Effects of sub-conjunctival cortisone upon the immediate union of corneal grafts. *Am J Ophthalmol* **34**:977-981
- Newsome D A, Gross J 1977 Prevention by medroxyprogesterone of perforation in the alkali-burned rabbit cornea : inhibition of collagenolytic activity. *Invest Ophthalmol Vis Sci* **16**:21-31
- Nuss RC, Puliafito CA, Dehm EJ 1987 Unscheduled DNA synthesis following excimer laser ablation of the cornea in vivo. *Invest Ophthalmol Vis Sci* **28**:287-294
- O'Brart DPS, Gartry DS, Lohmann CP, Kerr Muir MG, Marshall J 1994a Excimer laser photorefractive keratectomy for myopia: comparison of 4.00 and 5.00-millimetre ablation zones. *Refract Corneal Surg* **10**:87-94
- O'Brart DPS, Lohmann CP, Klonos G, Corbett MC, Pollock WST, Kerr Muir MG, et al 1994b The effects of topical corticosteroids and plasmin inhibitors on refractive outcome, haze, and visual performance after photorefractive keratectomy. *Ophthalmology* **101**:1565-74
- Orssaud C, Ganem S, Binaghi M, Patarin D, Putterman M, Viens Bitker C, et al 1994 Photorefractive keratectomy in 176 eyes : One year follow-up. *J Ref Corneal Surg (Suppl)* **10**:S199-S205
- Patel CKN 1964 Interpretation of carbon dioxide optical laser experiments. *Phys Rev Lett* **12**:588
- Pepose JS, Laycock KA, Miller JK, et al 1992 Reactivation of latent herpes simplex virus by excimer laser photokeratectomy. *Am J Ophthalmol* **114**:45-50

- Piebenga LW, Matta CS, Deitz MR, Tauber J, Irvine JW, Sabates FN 1993 Excimer photorefractive keratectomy for myopia. *Ophthalmology* 100:1335-1345
- Pitts DG, Cullen AP, Hacker PD 1977 Ocular effects of ultraviolet radiation from 295nm-365nm. *Invest Ophthalmol Vis Sci* 16:932-939
- Phillips K, Arffa R, Cintron C, et al 1983 Effects of prednisolone and medroxyprogesterone on corneal wound healing, ulceration and neovascularisation. *Arch Ophthalmol* 101:640-643
- Polack FM, Rosen PN 1967 Topical steroids and tritiated thymidine uptake : Effect on corneal healing. *Arch Ophthalmol* 77:400-412
- Puliafito CA, Steinert RF, Deutsch TF, Hillenkamp F, Dehm EJ, Adler CM 1985 Excimer laser ablation of the cornea and lens. Experimental studies. *Ophthalmology* 92:741-748
- Rashid ER, Waring GO 1989 Complications of radial and transverse keratotomy. (Major review) *Surv Ophthalmol* 34:73-106
- Rice S, Jain K 1984 Direct high-resolution excimer laser photoetching. *Applied Physics A - Solids and Surfaces* 33:195-198
- Rogers CM, Lawless MA, Cohen PR 1994 Photorefractive keratectomy for myopia of more than -10 dioptries. *J Ref Corneal Surg (Suppl)* 10:S171-S173
- Salz JJ, Maguen E, Nesburn AB, et al 1993 A two year experience with excimer laser photorefractive keratectomy for myopia. *Ophthalmology* 100:873-882
- Sampath R, Ridgway AEA, Leatherbarrow B 1994 Bacterial keratitis following excimer laser photorefractive keratectomy: a case report. *Eye* 8:481-482
- Sato T 1939 Treatment of conical cornea (incision of Descemet's membrane). *Acta Soc Ophthalmol Jpn* 43:544-555

- Searles SK, Hart GA 1975 Stimulated emission at 281nm XC. Br Appl Phys Lett 27:243-245
- Seiler T, Marshall J, Rothery S, Wollensak 1986 The potential of an infrared hydrogen fluoride (HF) laser (3.0 microns) for corneal surgery. Lasers Ophthalmol 1:49
- Seiler T, Bende T, Wollensak J, Trokel SL 1988a Excimer laser keratectomy for correction of astigmatism. Am J Ophthalmol 105:117-124
- Seiler T, Bende T, Winckler K, Wollensak J 1988b Side effects in excimer corneal surgery. Graefe's Arch Clin Exp Ophthalmol 226:273-276
- Seiler T, Kriegerowski M, Schnoy M, Bende T 1990a Ablation rate of human corneal epithelium and Bowman's layer with the excimer laser (193nm) Refract Corneal Surg 6:99-102
- Seiler T, Kahle G, Kriegerowski M, Bende T 1990b Myopic excimer laser (193nm) keratomileusis in sighted and blind human eyes. Refract Corneal Surg 6:165-73
- Seiler T, Wollensak J 1991 Myopic photorefractive keratectomy with the excimer laser. 1 year follow-up. Ophthalmology 98:1156-63
- Seiler T, Holschbach A, Derse M, Jean B, Genth U 1994 Complications of Myopic Photorefractive Keratectomy with the Excimer Laser. Ophthalmology 101:153-160
- Serdarevic O, Darrell RW, Krueger RR, Trokel SL 1985 Excimer laser therapy for experimental Candida keratitis. Am J Ophthalmol 99:534-538
- Serdarevic O 1989 Chapter 24: Corneal laser surgery In: L'Esperance F (ed) Ophthalmic Lasers (3rd Edition). CV Mosby, St Louis, p.918-923

- Sher NA, Chen V, Bowers RA, Frantz JM, et al 1991 The use of the 193-nm excimer laser for myopic photorefractive keratectomy in sighted eyes. A multicenter study. *Arch Ophthalmol* **109**:1525-30
- Sher NA, Barak M, Daya S, DeMarchi J, Tucci A, Hardten DR, et al 1992 Excimer laser photorefractive keratectomy in high myopia. A multicenter study. *Arch Ophthalmol* 1992;**110**:935-943
- Sher NA, Hardten DR, Fundingsland B, DeMarchi J, Carpel E, Doughman DJ, et al 1994 193-nm Excimer Photorefractive Keratectomy in High Myopia. *Ophthalmology* **101**:1575-1582
- Sher NA, Frantz JM, Talley A, Parker P, Lane SS, Ostrov C, et al 1993 Topical diclofenac in the treatment of ocular pain after excimer photorefractive keratectomy. *Ref Corneal Surgery* 1993;**9**:425-436
- Shimizu K, Amano S, Tanaka S 1994 Photorefractive keratectomy for myopia : One year follow-up in 97 eyes. *J Ref Corneal Surg (Suppl)* **10**:S178-S187
- Sliney DH 1991 Safety of ophthalmic excimer lasers with an emphasis on compressed gases. *Refract Corneal Surg* **7**:308-314
- Sliney DH, Krueger RR, Trokel SL, Rappaport KD 1991 Photokeratitis from 193nm argon-fluoride laser radiation. *Photochemistry and Photobiology* **53**:739-744
- Sorsby A, Sheridan M, Leary GA, Benjamin B 1960 Vision, visual acuity and ocular refraction of young men. *Br Med Journal* **1**:1394-1398
- Sperduto RD, Seigel D, Roberts J, et al 1983 Prevalence of myopia in The United States. *Arch Ophthalmol* **101**:405-407
- Srinivasan R, Mayne-Banton V 1982 Self-developing photo-etching of polyethylene terephthalate films by far ultraviolet excimer laser radiation. *Appl Phys Lett* **41**:576-578

- Sugar J, Chandler JW 1974 Experimental corneal wound strength. *Arch Ophthalmol* **92**:248-249
- SundarRaj N, Geiss MJ, Fantes F, et al 1990 Healing of excimer laser ablated monkey corneas. *Arch Ophthalmol* **108**:1604-1610
- Sutcliffe E, Srinivasan R 1987 Dynamics of the ultraviolet laser ablation of corneal tissue. *Am J Ophthalmol* **103**:470-471
- Taboada J, Mikesell GW, Reed RD 1981 Response of the corneal epithelium to krypton fluoride excimer laser. *Health Phys* **40**:677-683
- Tassman IS 1932 Frequency of the various kinds of refractive errors. *Am J Ophthalmol* **15**:1044-1063
- Taylor DM, L'Esperance FA, Del Pero RA 1989 Human excimer laser lamellar keratectomy: A clinical study. *Ophthalmology* **96**:654-664
- Taylor HR, Guest CS, Kelly P, Alpins NA, et al 1993 Comparison of excimer laser treatment of astigmatism and myopia. *Arch Ophthalmol* **111**:1621-1626
- Tengroth B, Epstein D, Fagerholm P, Hamberg-Nystrom H, Fitzsimmons TD 1993 Excimer laser photorefractive keratectomy for myopia. Clinical results in sighted eyes. *Ophthalmology* **100**:739-745
- Tenner A, Neuhann T, Schroder E, et al 1988 Excimer laser radial keratotomy in the living human eye: a preliminary report. *J Refract Surg* **4**:5-8
- Thornton SP 1990 Astigmatic keratotomy: a review of basic concepts with case reports. *J Cataract Refract Surg* **16**:430-435
- Thygeson P 1977 The unfavourable role of corticosteroids in herpetic keratitis. In : Brockhurst RJ, Boruchoff AS, Hutchinson BT, Lessell S (eds) *Controversy in Ophthalmology*, WB Saunders, Philadelphia, p.450-469.

- Trentacoste J, Thompson K, Parrish RK, Hajek A, Berman MR, Ganjei P 1987
Mutagenic potential of a 193nm excimer laser on fibroblasts in tissue culture.
Ophthalmology **94**:125-129
- Trokel SL, Srinivasan R, Braren B 1983 Excimer laser surgery of the cornea. *Am J
Ophthalmol* **96**:710-715
- Tuft SJ, Marshall J, Rothery S 1987 Stromal remodelling following photorefractive
keratectomy. *Lasers in Ophthalmol* **1**:177-185
- Tuft SJ, Boulton ME, Marshall J 1989a Assessment of corneal wound repair in vitro.
Curr Eye Res **8**:713-719
- Tuft SJ, Zabel RW, Marshall J 1989b Corneal repair following keratectomy : A
comparison between conventional surgery and laser photoablation. *Invest
Ophthalmol Vis Sci* **30**:1769-1777
- Tuft SJ, Gartry DS, Rawe IM, Meek KM 1993 Photorefractive keratectomy :
Implications of corneal wound healing. *Br J Ophthalmol* **77**:243-247
- Waring GO 1985 Making sense of keratospeak: a classification of refractive corneal
surgery. *Arch Ophthalmol* **103**:1472-1477
- Waring GO, Lynn MJ, Culbertson W, et al 1987 Three-year results of the prospective
evaluation of radial keratotomy (PERK) study. *Ophthalmology* **94**:1339-1354
- Waring GO 1988 Radial keratotomy in The United States : The turbulent decade
J Refract Surg **4**:204-208
- Waring GO, Lynn MJ, Nizam A, et al 1991 Results of the prospective evaluation of
radial keratotomy (PERK) study 5 years after surgery for myopia. *Ophthalmology*
98:1164-1176

Waring GO 1992a In 'Refractive keratotomy for myopia and astigmatism'. Chapter 23, Mosby Yearbook, St Louis, USA, p.917.

Waring GO 1992a In 'Refractive keratotomy for myopia and astigmatism'. Chapter 23, Mosby Yearbook, St Louis, USA, p.917.

Waring GO 1992b In 'Refractive keratotomy for myopia and astigmatism'. Chapter 4, Mosby Yearbook, St Louis, USA, p.166.

Weale RA 1982 A biography of the eye - development, growth, age. HK Lewis, London, UK

Yamaguchi T, Polacz FM, Kaufman ME 1981 Endothelial damage after anterior radial keratotomy : An electron microscopic study of rabbit cornea. Arch Ophthalmol 99:2151-2158

Zabel R, Tuft SJ, Marshall J 1988 Excimer laser photorefractive keratectomy: endothelial morphology following area ablation of the cornea. Invest Ophthalmol Vis Sci 29:390 (Abstract)

Zabel RW, Tuft SJ, Fitzke FW, Marshall J 1989 Corneal topography : A new photokeratoscope. Eye 3:198-301

Zabel RW, Sher NA, Ostrov CS, Parker P, Lindstrom RL 1990 Myopic excimer laser keratectomy: a preliminary report. Refract Corneal Surg 6:329-334

APPENDIX I

CONSENT AND BACKGROUND INFORMATION FORMS

INFORMED CONSENT FOR USE OF THE EXCIMER LASER FOR PRK

Notes for patient's guidance

The information given here is intended to be a summary of the discussions that have taken place between the patient and the clinical investigators - Mr M G Kerr Muir and Mr D S Gartry - in relation to the excimer laser. It includes the salient details of the research study and its implications.

Background

Excimer laser photorefractive keratectomy (PRK) is a new method for altering the shape of the front of the eye (the cornea) as a treatment for myopia. A thin, superficial layer of corneal tissue is removed in a precisely controlled fashion. The cornea essentially undergoes reprofiling or resculpting. By inducing this change it is hoped to reduce the amount of myopia (short-sight) or, in some suitable cases, eliminate it altogether.

Several years' experience has been built up in the laboratory setting and 2 years' clinical experience at St Thomas' Hospital using the laser to treat abnormal corneal conditions. The results so far have been very encouraging.

Since November 1989, 16 patients have undergone excimer laser PRK in a blind eye and(number of patients to date) 'normal' myopic individuals. No serious complications have ensued although the follow-up period at present is short. From these results, and those of other researchers in the same area, it is possible to state that no significant long-term side effects are envisaged and consequently we have now reached the stage at which it is appropriate to set up a clinical research study to investigate PRK in eyes 'suffering' only from myopia.

For the purposes of this study it is important to understand that you will be required to attend for follow-up examinations at intervals throughout the study period (a total of 14 visits in the first year).

The procedure

This requires only local anaesthesia in the form of eyedrops and is painless. The procedure lasts approximately 30 minutes with the actual laser exposure lasting only 10 to 20 seconds. After the treatment the eye will be padded for 24 hours and you will be expected to apply eyedrops daily, as instructed. The eye will be quite sore a few hours after the procedure and you will probably need to take painkillers (for example, paracetamol tablets). The following day this soreness will have improved considerably and 48 hours later the eye will feel virtually normal.

Longer-term effects

The main questions that we are asking in this study relate to the efficacy of PRK in altering the degree of myopia that you have. We will be investigating the stability of the change and whether there is a tendency for the eye to revert back to the original amount of myopia. We already know that some corneal haze occurs which becomes less obvious with time and it is possible that there might be some permanent reduction in your

maximum level of vision, although we anticipate that, if this occurs, the effect will be only slight. There is however **no guarantee** as to the final outcome and in those cases in which we attempt to fully correct the existing myopia there is **no guarantee** that spectacles will no longer be required.

For the purpose of this study we will only be treating **one eye** and therefore we anticipate that in cases where both eyes were originally myopic to the same degree there will be an inevitable imbalance between the 2 eyes after the surgery. In cases in which an equally high degree of myopia exists in both eyes it will only be possible to **reduce** the amount of myopia in one eye, rather than correcting it completely, in order to avoid an intolerable difference in the image sizes of the 2 eyes. Where the situation exists in which one eye is significantly more myopic than the other the more myopic eye will be treated in an attempt to reduce or eliminate the difference between the 2 eyes. Where suitable it may be possible to aim to make the most myopic eye the least myopic of the two.

It may be possible to treat the other eye in the future, in which case any induced imbalances may be corrected, however a reasonable length of follow-up will be required (provisionally one year) before we are in a position to embark upon treatment of the second eye. This is because we must be satisfied that the procedure is safe in the long-term before treating both eyes.



D S Gartry and M G Kerr Muir

January 1990

INFORMED CONSENT FOR OPERATION

I _____ of _____
(name) (address)

hereby consent to undergo the procedure of _____ (eye) excimer laser photorefractive keratectomy (PRK) for the treatment of my myopia.

I understand that I am agreeing to participate in a research study and I have read the attached notes. I have also had ample opportunity to discuss the nature and implications of the research study with Mr D S Gartry and/or Mr M G Kerr Muir.

In signing this consent form I confirm that I understand that I will be required to attend for regular follow-up examinations. I also confirm by signing this consent form that I understand that the outcome of PRK can not, at present, be accurately predicted and there is **no guarantee** that there will not be long-term, harmful, side-effects or that the change in my refractive error (degree of myopia) will be stable.

Signed _____ Date _____
(signature of patient)

Signed _____ Date _____
(signature of surgeon)

QUESTIONNAIRE

1. **Name**
2. **Address**

Telephone	Home	Work
------------------	-------------	-------------
3. **Age**
4. **Occupation**
5. **What is your spectacle prescription (the strength of your glasses)?**

Please forward an 'up to date' spectacle prescription. Please note this must be a SPECTACLE prescription rather than a contact lens prescription and if possible please send either the actual prescription or a photocopy. In addition, If possible ensure that the prescription is no more than 3 months old.

6. **Do you wear contact lenses?**

If so :

What type are they?

How long have you worn contact lenses?

How regularly do you wear them?

How long can you wear them each day?

Have you had any problems with them?

7. **What are your reasons for wanting to have your myopia corrected by excimer laser?**

Questions and answers

1. Can this surgery correct all degrees of myopia?

We have found from our studies to date at St Thomas' Hospital that the best results are obtained when treating low to moderate amounts of myopia. Since the vast majority of short-sighted people fall within this category, excimer laser surgery is potentially suitable for most individuals who are myopic. When higher degrees of myopia are treated there is a significant trend towards undercorrection but nevertheless many of these patients derive considerable benefit from the reduction in their prescription.

2. Can astigmatism be corrected?

At the present time it is not possible to correct astigmatism. We have shown that there is no significant difference between pre- and post-operative astigmatism. The majority of myopic patients will however have relatively little astigmatism in comparison to their myopia and you will be advised about this once details of your spectacle prescription are known.

3. Can long-sightedness (hyperopia) be treated?

Again, at the present time this is not possible, although research is underway to address this problem.

4. Is the effect permanent?

It is quite likely that after the surgery you will be slightly long-sighted. As the eye heals this 'hyperopia' is lost and your vision will go through a phase where it may be close to perfect. Final stabilisation however occurs between 3 to 4 months from the time of surgery and of the 400 patients already treated at St Thomas' Hospital there has been no significant change beyond this time.

5. Will all of my myopia be corrected?

Results to date show that there is a 75 to 80% chance of low to moderate degrees of myopia being virtually eliminated. Even when higher degrees are treated around 80% of patients have their myopia reduced by at least half giving considerable benefit and less dependence on spectacles or contact lenses.

6. Is excimer laser surgery invasive?

While this surgery is under computer control for the main part it is still a surgical operation and as such should only be performed by Ophthalmic Surgeons experienced in the technique. The amount of tissue removed is minimal (around 5% of the corneal thickness) and it can therefore be considered minimally invasive particularly when compared with other forms of refractive surgery eg radial keratotomy.

7. Is excimer laser surgery safe?

Research over the past 8 years has addressed this question in detail, both in the laboratory and at St Thomas' Hospital. To date, although the technique certainly has complications we have not identified any serious side effect in our patients.

8. What complications have occurred?

The main complications are two-fold :

a. A variable degree of surface corneal haze can develop over 3 to 6 months which then begins to clear. This can only be detected with a high power microscope, however, there is a possibility (approximately 10 to 15% of the patients with greater amounts of myopia) that your maximum level of vision may be reduced. In the majority of patients therefore there is little, if any, effect on vision.

b. In the first 2 to 3 months after surgery some patients experience a 'glow' or 'halo' effect around lights at night. This is related to the size of the patient's pupil and the larger the pupil the greater the effect. We have estimated that around 10% of patients are troubled by this and patients with large pupils (who are usually younger) will be advised not to proceed at the present time.

Other relatively minor complications include a slight tenderness of the eye on rubbing or a slight foreign body sensation on waking in the first few months. Otherwise the eye feels entirely normal.

9. What age limits are there?

The lower age limit that we advise is 24. By this age the growth of the eye is virtually complete and the spectacle prescription is stable. We have treated younger patients where a clinical indication was present eg a large difference between the 2 eyes which could be eliminated. There is no upper age limit - the oldest patient treated so far being 67.

10. When will my other eye be operated?

From the results of their research, the St Thomas' team feel that 6 months is a reasonable interval. By this time the first eye has settled completely and based on the progress made by the first eye it may be possible to improve accuracy for the second.

11. How will I cope with the difference between the eyes in this period?

The best way to attempt to balance the eyes is one contact lens worn in the non-operated eye. Those patients who do not wear contact lenses usually manage with spectacles in which one lens is clear glass (ie there is no power in the lens). The difficulty encountered because of the difference is related to the amount of myopia present initially and for low to moderate degrees is minimal.

12. Will driving be affected after the surgery?

We would advise that you refrain from driving if possible for 1 to 2 weeks after surgery to give an opportunity for adjustment to the new situation. You will be quite legal to drive (by virtue of the unoperated eye) but you must feel comfortable before doing so. This will vary from person to person.

13. If my myopia is not completely eliminated could any residual amount be treated with a second procedure?

Yes, although it is likely that, while the residual amount of myopia can be reduced, it might not be possible to eliminate it completely.

14. How much time will I need to take off work after the operation?

We have found that most patients can cope with going back to work 3 to 4 days after the treatment. This again is a personal thing depending on the demands of an individual's work.

15. How long will I need to stay in the excimer laser clinic on the day of the surgery?

You will only be required to attend for around 30 minutes. Since all pre-operative tests will have been performed on a previous occasion this time is devoted to the treatment and includes time for any further questions that you might have, familiarising yourself with the laser, practising the technique and the time for the actual laser treatment.

16. What will I experience during the procedure?

The laser light is invisible and therefore can not be seen during the 12 seconds or so that the laser is working. Having had anaesthetic eyedrops applied before the surgery you will feel nothing at all during the procedure although the eye will be very sore 2 to 3 hours later. You will however be able to hear the laser in operation but this has not been of any consequence for the patients treated so far.

17. How soon can I go swimming after the procedure?

We recommend that you refrain from swimming for one month to allow time for the surface of the eye to heal completely.

18. Should I be accompanied on the day of the surgery?

Yes, if at all possible. An eyepad will be applied after the procedure and it is a little disconcerting to have to negotiate London traffic with one eye covered.

19. What follow-up visits are involved?

We would ask that you attend the following day, one week, one month, 4 months and one year later in order that we can carefully monitor your progress. The research database that we have established will help patients in the future. We would also ask therefore that you have a consultation on an annual basis thereafter so that we can keep progress records up to date for all of our patients. Each visit will take no more than 30 minutes.

20. Will there be any effect on my reading (close) vision?

As you will know already, being short-sighted means that you have excellent close vision without spectacles. You will have found also that you need to wear spectacles most of the time even when reading since you also need to see across the room. The treatment will, hopefully, give you excellent vision without spectacles but if you are middle-aged you will find that you can no longer remove your spectacles to read small print and you may need reading spectacles (as you would have needed had you enjoyed perfect sight all your life).

**D S Gartry FRCS, FCophth
August 1991**

**Iris Fund Research Fellow
St Thomas' Hospital**

CORRECTION OF MYOPIA WITH THE EXCIMER LASER

PHOTOREFRACTIVE KERATECTOMY (PRK)

**Mr D S Gartry FRCS
The Lambeth Wing Eye Department
St Thomas' Hospital
London SE1 7EH**

EXCIMER LASER PHOTOREFRACTIVE KERATECTOMY (PRK)

Background information

A. Basic principles

Around 10 million people in the United Kingdom suffer the inconvenience of myopia. This condition - also termed shortsightedness - is an optical defect of the eye in which light rays are brought to a focus in front of the light-sensitive film at the back of the eye (the retina) with the result that distant objects are blurred.

Myopia results when either the front surface of the eye (the cornea) is too highly curved or the eye is relatively too large.

A combination of both factors may contribute to the final amount of myopia. Even small degrees of myopia are relatively disabling and will result in objects more than 2 to 3 feet away being out of focus. The traditional methods of treating myopia are, of course, spectacles and contact lenses but as most sufferers will admit, these have a nuisance value at the best of times and most lens wearers would be grateful to be less dependent on artificial optical aids.

B. The excimer laser - the latest treatment for myopia.

Excimer laser photorefractive keratectomy (PRK) is a new method for altering the shape of the front surface of the eye (the cornea). Since this surface is responsible for approximately 2/3 of the focusing required to produce an image on the retina any subtle change in its curvature has a relatively large effect on the position of the image. The excimer laser can remove a thin, superficial layer of corneal tissue with an unprecedented degree of precision and without any damage to the rest of the eye. Essentially, the cornea undergoes re-profiling or re-sculpting and by utilising the precision of the laser to directly reduce the curvature of the cornea, myopia (short-sightedness) can be corrected.

This technique is quite distinct from radial keratotomy (popularised in Russia) which has not gained widespread acceptance in the UK. In this procedure radial cuts are made in the cornea with a diamond knife with the intention that the resultant weakening will lead to a secondary flattening and hence a reduction in myopia. For the flattening effect to occur the surgeon aims to cut to a depth of around 90 to 95% of the corneal thickness. Perforations into the eye have occurred. The wounds produced can be unstable and fluctuation in vision can occur throughout the day as well as over longer periods of time. The incisions can also give rise to scatter of light and glare.

In contrast, the research at St Thomas' Hospital has shown that excimer laser photorefractive keratectomy (PRK) can correct moderate degrees of myopia by removing no more than 5% to 10% of the corneal thickness. There is an exceptionally high degree of accuracy in the removal of tissue and the laser, which is under computer control, can be programmed to correct different amounts of myopia directly. While this is still a surgical procedure it is minimally invasive and the strength and integrity of the eye are not affected.

C. History of excimer laser photorefractive keratectomy.

Investigation into the use of excimer lasers in ophthalmic surgery began in 1983. Extensive laboratory studies were conducted in the UK London University's Institute of Ophthalmology and in February 1988 the first patient with corneal disease (quite distinct from simple myopia) of a prospective series was treated with the excimer laser at St Thomas' Hospital, London¹. The first UK studies designed to investigate the treatment of myopia using this laser commenced in November 1989 and since that time over 300 PRK procedures have been carried out at St Thomas'. Overall the results have been encouraging. It has been found however that it is much more difficult to achieve good results in patients who are highly myopic (greater than -10.00 dioptries)^{2,3}. The vast majority of people who are short-sighted are considerably less myopic than this (less than -6.00 dioptries) and the predictability and stability of the outcome in these patients are good. In addition, the St Thomas' team have found no serious complications in these patients.

There are only 3 side effects of importance :

1. A tendency for the treated eye to lose some of the effect of the surgery in the first 3 to 4 months. An over-correction is attempted during the surgery to offset this trend.
2. If the surgery is particularly effective a "halo" effect around lights at night may be experienced in patients with particularly large pupils. This effect decreases during the first few months has been found to be problematic in around 10% of patients.
3. A variable degree of corneal haze occurs which becomes less obvious with time. This haze can only be detected by use of a high-powered microscope but it is possible that, due to this haze, there may be some permanent reduction in the maximum level of vision. There is however no guarantee as to the final outcome and in those cases in which we attempt to correct the myopia fully there is no guarantee that spectacles will no longer be required.

From our results and those of surgeons in Germany and the United States it can be concluded that serious longer term side-effects, while not impossible, are highly unlikely.

D. Suitability for the procedure.

On returning the enclosed questionnaire Mr Gartry and/or Mrs Armstrong will assess your basic suitability for the procedure. An appointment will then be arranged for further discussion. If, after this stage, it appears that you are suitable for the surgery, a consultation for a full eye examination will be arranged and on satisfactory completion of this the date for the laser surgery will be given.

The procedure and post-operative period

This requires only local anaesthesia in the form of eyedrops and is painless. The procedure lasts approximately 15 minutes with the actual laser exposure lasting only an average of 12 seconds. After treatment an eye pad is applied and the patient returns home. The eye is quite sore 2 to 3 hours after the procedure and painkillers are prescribed. The following day this soreness will have improved considerably and 48 hours later the eye will feel essentially normal. After removing the pad the day following surgery, eyedrops are used for 2 weeks to ensure normal recovery. Vision is usually considerably improved within 3 to 4 days and most patients become slightly long-sighted for a few weeks before settling to the final level of correction. Regular follow-up visits are necessary in the first year.

We have shown that around 80 to 90% of patients with low to moderate degrees of myopia (up to -4.00 dioptries) achieve near perfect vision following the surgery and in many cases do not need to use spectacles or contact lenses again. Even patients with higher levels of myopia (greater than -6.00 dioptries) achieve a reduction in spectacle prescription of at least half³. These patients are therefore considerably less dependent on spectacles or contact lenses and their unaided vision is markedly improved. There has therefore been a very high level of patient satisfaction with this procedure.

References

1. Superficial keratectomy with the argon fluoride excimer laser - A laboratory and clinical study.
D S Gartry, M G Kerr Muir, J Marshall.
British Journal of Ophthalmology 1991;75:258-269
2. Excimer lasers and refractive surgery.
Transactions of The British College of Optometrists 10th Annual Congress 1990 24 Butterworths
J Marshall, D S Gartry, M G Kerr Muir.
3. Photorefractive keratectomy with the argon fluoride excimer laser - a clinical study.
D S Gartry, M G Kerr Muir, J Marshall.
Journal of Refractive and Corneal Surgery 1991;7:1-16

St Thomas' Hospital Photorefractive Keratectomy Program

Patient Selection Criteria / Protocol

A. Sex

No exclusion criterion relating to gender.

B. Age

Minimum age 24 years (to allow for stabilisation of myopia). Exceptions to this will include patients with a difference between the two eyes in order to redress the balance (the more myopic of the 2 eyes undergoing surgery).

C. Degree of myopia

On the basis of the research carried out at St Thomas' Hospital by Mr D S Gartry and Mr M G Kerr Muir it is now recommended that the maximum level of correction attempted should be -6.00 dioptres. The most predictable results are in the treatment groups up to -4.00 dioptres and all patients should be warned that they may achieve only partial correction of their myopia.

D. Astigmatism

Patients should have less than 1.00 dioptre of astigmatism. Exceptions to this might be those patients with around -6.00 dioptres of myopia in whom a large improvement can be expected and in whom 1.50 or 2.00 dioptres of astigmatism represents proportionately less of their overall ametropia. Upon counselling the patient preoperatively it should be explained that astigmatism can not be treated at the present time with this technique and the maximum possible improvement demonstrated leaving the astigmatism uncorrected.

E. Treatment of the other eye

There should be a minimum period of 6 months between treatment of the 2 eyes. This allows stabilisation of refraction in the first eye. Our original protocol required a minimum period of 1 year but we feel that this can be revised in the light of our experience at St Thomas'.

F. Contact lens wear

Given that there will be a period during which one eye may be almost normally sighted and therefore an imbalance will exist between the 2 eyes, patients able to wear one contact lens (in the eye awaiting treatment) will achieve the most comfortable binocular vision during this period. This is an important part

of pre-operative counselling and it is particularly important to emphasise this in the case of the higher myopes undergoing treatment.

G. Occupation

Patients with particularly demanding occupations with high visual requirements eg pilots and professional drivers should not be treated. In those wishing to join the armed forces, police, fire service etc the patient will be required to verify that the force/service will not automatically reject his application on the grounds of the surgery. It should be made quite clear at the outset that night vision may be reduced and therefore night driving in the course of eg police work might be inappropriate.

H. Ocular or General Pathology

All patients should undergo complete ophthalmological examination and any patient with a history of eye disease or in whom an abnormal ocular condition is discovered at examination will be excluded. Patients with general disorders, such as diabetes, and in particular collagen vascular disorders will be excluded (because of potential difficulties with wound healing).

I. Pupil Size

Patients with large pupils are likely to experience a 'halo effect' around lights at night. This will also depend upon the amount of correction attempted (the greater the attempted correction the larger the halo effect). Patients undergoing corrections from -4.00 to -6.00 with pupil diameter larger than 6mm in subdued lighting should be excluded.

J. Other

Social circumstances should be taken into account. In particular patients about to take important examinations should be excluded until such time as they can undergo surgery without jeopardising career opportunities etc.

Selection - General

The above guidelines, which have been derived from the St Thomas' experience over the past 2 years, should be applied in selecting suitable patients for excimer laser surgery.

We consider that it is important that prospective patients are counselled by a surgeon experienced in the technique so that a fair representation of the surgery and its limitations are given and all questions raised can be answered.

All prospective patients will be given detailed written background information on the technique which, in addition to counselling by the surgeon, will provide adequate information to allow an informed consent form to be signed.

Pre-operative examination/Assessment

This should consist of :

History (including family history)

Refraction and oculomotor balance assessment

Full ophthalmological examination including pupil dilation and indirect ophthalmoscopy

Keratometry

(NB Soft contact lens wearers will be required to leave the lenses out for one week prior to this examination while hard and gas permeable contact lens wearers will leave lenses out for one month. All patients will be asked to provide the results of previous eye tests to enable an assessment of stability of refraction to be made).

Post-operative examination

All the above with exception of history.

Patients will however be asked to report symptoms/problems encountered.

Post-operative follow-up schedule.

This will be as follows :

- The day following surgery
- One week
- One month
- Three months
- Six months
- One year.....and annually thereafter

It will be emphasised to patients that they must contact the surgeon as soon as possible if they experience any new symptoms and arrange early follow-up as required.

NB This schedule has been derived from the St Thomas' experience in which patients were originally requested to attend for follow-up a total of 14 times in the first year. It is unnecessary to impose this number of visits on patients since the pattern of progress post-operatively is now known to the St Thomas' surgeons and the number of visits can now be reduced in the light of their experience.

D S Gartry FRCS,FCophth
Iris Fund Research Fellow, St Thomas' Hospital, London
September 1991

EXCIMER LASER SURGERY FOR CORRECTION OF MYOPIA

STEROID TRIAL - INFORMED CONSENT

I, _____ (name) of

(address)

hereby consent to undergo the procedure of excimer laser photorefractive keratectomy for correction of myopia in my _____ eye.

I have read the background information accompanying this consent form and have been given ample opportunity to discuss the procedure with Mr D S Gartry prior to reaching a decision to take part in the trial.

I understand that this is a research trial and the outcome of the surgery can not be guaranteed. I have also been informed of the possible complications associated with this form of treatment.

I also understand that the main purpose of this trial is to determine whether steroid eyedrops have any influence on the final outcome of the surgery and I appreciate that I will receive either steroid eyedrops or weak salt solution eyedrops (placebo) in the post-operative period (3 months). I confirm that I will comply with the instructions for administration of these drops.

(It is intended that neither the patient nor the surgeon will know which drops are being used until a specified period after the surgery).

_____ signature of patient

_____ signature of surgeon

_____ date

APPENDIX II

PATIENT SELECTION CRITERIA ARISING FROM THE STUDY

PRK PATIENT SELECTION CRITERIA

The following guidelines have been derived from peer-reviewed publications from current studies published up to the end of 1994 (Table XVII). It is important that prospective patients are counselled by a surgeon experienced in the technique so that a fair representation of PRK and its limitations are given and all questions raised can be answered. Detailed written background information should be given which, in addition to counselling by the surgeon, should allow an informed consent to be signed. It is most important that prospective patients have realistic expectations in relation to the procedure. This may mean excluding patients on psychological grounds, those who are by nature perfectionists or those who would be most unhappy with anything other than perfect unaided vision. In keeping with the guidelines issued by The Royal College of Ophthalmologists and endorsed by The British College of Optometrists all prospective patients must be referred via their General Practitioner.

Sex

There is no exclusion criterion relating to gender with the exception of caution expressed in relation to pregnancy. Since some authorities advocate the use of high dose topical corticosteroids for several months post-PRK (see below) most would exclude pregnant patients. In addition, corneal wound healing characteristics may be altered in pregnancy.

Age

The minimum age should be 21 to ensure stabilisation of myopia. This should be confirmed by scrutiny of optometric records. Exceptions, however, might include patients with a significant difference in refraction between the 2 eyes (anisometropia) in whom the more myopic of the 2 eyes is treated to eliminate this difference. However, the social and work circumstances of the prospective patient must be considered carefully and, because of the relatively prolonged visual rehabilitation post-PRK, it might not be appropriate to treat a 21 year old who is studying for important examinations. Presbyopic or borderline presbyopic patients must be counselled carefully with regard to their almost certain need for reading spectacles if their myopia were to be eliminated completely. This is particularly important for those patients with low to moderate degrees of myopia who may have become accustomed to reading comfortably unaided.

Ocular or Systemic Pathology

All patients should undergo complete ophthalmological examination and any patient with previous ocular disease or abnormality (for example, dry eye, keratoconus, glaucoma, herpes simplex keratitis, amblyopia) should be excluded. It is now accepted, as best clinical practice, that videokeratoscopy should be carried out in order to exclude patients with undiagnosed corneal pathology. Patients with systemic disorders, such as diabetes, and in particular autoimmune or collagen vascular disorders, such as rheumatoid arthritis, systemic lupus erythematosus, or polyarteritis nodosa, should be excluded because of potentially serious problems of wound healing (Seiler et al, 1991).

Amount of myopia

As discussed above, the individual variability in corneal wound healing and incidence of complications after PRK increases as greater amounts of myopia are treated. Predictability of refractive outcome varies inversely with degree of myopia and is relatively good up to -4.00D and poor beyond -10.00D. There is no absolute divide between success and failure but at the -6.00D or -7.00D treatment level there is a 'watershed zone' below which predictability is acceptable but above which predictability becomes progressively worse. Successful results above -9.00D or -10.00D are often quoted in support of PRK for high myopia but, since predictability is poor, they are the exception rather than the rule. Several surgeons who have pioneered the technique of PRK have recommended that, at the present time, the maximum level of correction attempted should be up to around -6.00 or -7.00 dioptres. For example, in a recent update paper which addressed the complications of PRK, it was concluded that :

"Most of the complications such as reduction of glare vision, overcorrection, scarring, and continued regression are strongly dependent on the attempted refractive change. When refractions exceed -6.00D, the incidence of these complications reach, in our opinion, intolerable levels." (Seiler et al, 1994)

Although the most predictable results are in the treatment groups up to -4.00D, all patients should be warned that they may achieve only **partial correction** of their myopia. Although unusual, it is by no means impossible for a low myope (ie up to around -3.00D) to regress back to their original refractive state (Gartry et al, 1992a). This problem is encountered much more commonly with high myopes (Sher et al, 1992).

Astigmatism

At the present time the treatment of astigmatism is possible only with certain of the commercially available excimer lasers and results are more variable than for simple myopia. One study recently reported an average of around only a 55% reduction in astigmatism (Kim et al, 1994). Another concluded however, that excimer laser photoastigmatic keratectomy (PRK) "offers an effective option in the treatment of myopic astigmatism" (Taylor et al, 1993) although most patients treated had relatively small amounts of astigmatism (less than 1.50DC) and the change in most cases was variable and subtle, as highlighted in recent published correspondence (Lipschitz et al, 1994). In order to avoid disappointment, patients should have less than 1.00 dioptre of astigmatism (1.00DC) prior to PRK. This, however, is a relative guideline only and an exception, for example, might be a patient with around 5 or 6 dioptres of myopia in whom a large overall improvement in myopia can be expected and in whom 1.5 or 2 dioptres of astigmatism represents proportionately less of their total refractive error. Upon counselling patients preoperatively it should be explained that it is difficult to treat astigmatism predictably at the present time. The best possible unaided vision without correction of the astigmatic component can be demonstrated to the patient prior to treatment.

Treatment of the second eye

Generally, a minimum period of around 3 months between treatment of the 2 eyes in low myopia (up to -3.00D) and 6 months in the higher degrees of myopia (up to approximately -7.00D) is advised. This allows for stabilization of refraction and manifestation of complications in the first eye. Our original research protocols, subject to Ethics Committee approval, required a minimum period of 1 year but most authorities feel that this can be revised in the light of an increasing database worldwide.

Contact lens wear

Given that there is an interval after treatment of the first eye during which an imbalance exists between the 2 eyes (anisometropia), patients able to wear one contact lens in the untreated eye will achieve the most comfortable binocular vision during this period. This is particularly important in the case of high myopia since anisometropia can be marked.

Occupation

Great caution should be exercised when considering the treatment of myopes with particularly demanding occupations requiring high visual standards, for example pilots or professional drivers. Our early research protocols excluded patients in this category (see chapter 7, page 145) and, in view of the complications outlined below it could still be argued that these individuals should not be treated. Those wishing to join the armed forces, police, or fire service should verify that their prospective employer will not reject their application because PRK surgery has been performed. It should be emphasized that visual performance at night may be reduced and therefore night driving, in the course of, for example, police work, might be hazardous. In addition, it has been suggested that exposure to bright sunlight might cause loss of the effect of the surgery (regression) in the early post-PRK period although this is yet to be proven statistically.

Pupil size

With the use of small ablation diameters (4mm throughout our study) patients with large pupils experienced a 'halo effect' around lights at night. This is due to a contribution to the retinal image from untreated peripheral cornea - an extreme form of positive spherical aberration. This halo effect depends also upon the amount of correction attempted since the greater the attempted correction - and in particular the greater the change in refraction - the larger the effect. Patients undergoing corrections above -4.00D with pupil diameters larger than 6mm in subdued lighting should be counselled very carefully with regard to the likelihood of this complication. It is important also to consider driving habits. A younger patient, with relatively large pupils, who drives frequently at night could be expected to encounter significant halo problems. The newer generation of lasers has been designed to provide ablation zone diameters of around 6mm which minimise the problem (O'Brart et al, 1994).

APPENDIX III

PUBLICATIONS ARISING FROM THE PROJECT

APPENDIX III: PUBLICATIONS ARISING FROM THE PROJECT

This thesis describes the development of excimer laser corneal surgery and the studies conducted were the first systematic laboratory and clinical investigations of phototherapeutic keratectomy (PTK) and the first prospective clinical studies of photorefractive keratectomy worldwide. The data in this thesis provided the basis of the first UK publications relating to excimer laser phototherapeutic keratectomy (PTK) and photorefractive keratectomy (PRK).

Marshall J, Gartry DS, Kerr Muir MG, Mastellone GE 1989 Photochemical effects of lasers in refractive surgery. Proceedings of the V International Congress of Cataract and Refractive Microsurgery. Capelli Editore. p. 291-295.

Marshall J, Gartry DS, Kerr Muir MG 1990 Excimer lasers and refractive surgery. Transactions of The British College of Optometrists 10th Annual Congress, Butterworths, London p.24.

Gartry DS, Kerr Muir MG, Marshall J 1991 Excimer laser treatment of corneal surface pathology: a laboratory and clinical study. Br J Ophthalmol 75:258-269

Gartry DS, Kerr Muir MG, Marshall J 1991 Photorefractive keratectomy with an Argon Fluoride Excimer Laser : A Clinical Study. Refract Corneal Surg 7:420-435

Lohmann C, Gartry DS, Kerr Muir MG, Timberlake G, Marshall J 1991 "Haze" in photo-refractive keratectomy: Its origins and consequences. Lasers and Light in Ophthalmology 4:15-34

Lohmann C, Timberlake G, Fitzke F, Gartry DS, Kerr Muir MG, Marshall J 1991 The effect of changes in corneal transparency on visual acuity after photo-refractive keratectomy using an excimer laser. Invest Ophthalmol Vis Sci 32:721 (Abstract)

Gartry DS, Kerr Muir MG, Marshall J 1992 Hyperopic shift following superficial keratectomy with the argon fluoride excimer laser. Br J Ophthalmol 76:62-63

- Lohmann C, Gartry DS, Kerr Muir MG, Timberlake G, Fitzke F, Marshall J 1992
Corneal haze after excimer laser refractive surgery: objective measurements and functional implications. *Eur J Ophthalmol* 1:173-180
- Lohmann C, Fitzke F, Timberlake G, Gartry DS, Kerr Muir MG, Marshall J 1992
Corneal transparency after excimer laser photo-refractive keratectomy: A new technique for objective measurements of haze. *Refract Corneal Surg* 8:114-121
- Gartry DS, Kerr Muir MG, Marshall J 1992 Excimer Laser Photorefractive keratectomy - 18 month follow-up. *Ophthalmology* 99:1209-1219
- Gartry DS, Kerr Muir MG, Lohmann CP, Marshall J 1992 The effect of topical corticosteroids on refractive outcome and corneal haze after photorefractive keratectomy. *Arch Ophthalmol* 110:944-52
- Gartry D S, Muir M G K, Marshall J. 1992 Photorefractive keratectomy with an argon fluoride excimer laser : A clinical study *Key Ophthalmology* 7:26-27
- Lohmann C, Gartry DS, Kerr Muir MG, Timberlake G, Fitzke F, Marshall J 1992
Corneale Trübung nach photorefraktiver Keratektomie mit einem excimer lasers: urasache, objektive messungen und funktionelle konsequenzen. *Ophthalmologe* 89:498-504
- Gartry D S, Kerr Muir M G, Marshall J. 1992 Excimer laser photorefractive keratectomy. *Mosby Yearbook of Ophthalmology*. C V Mosby, St Louis.
- S J Tuft, D S Gartry, I Rawe, K Meek 1993 Photorefractive keratectomy : implications of corneal wound healing. *Br J Ophthalmol* 77:243-247
- Gartry D S, Kerr Muir M G, Marshall J 1993 Excimer Laser Photorefractive Keratectomy : 18 month follow-up. *Key Ophthalmology* 8:22

Gartry D S, Kerr Muir M G, Lohmann C P, Marshall J 1993 The effect of topical corticosteroids on refractive outcome and corneal haze after photorefractive keratectomy : a prospective, randomized, double-blind trial. *Key Ophthalmology* 8:23

Gartry DS, Kerr Muir MG, Marshall J 1993 The effect of topical corticosteroids on refraction and corneal haze following excimer laser treatment of myopia : an update. A prospective, randomised, double-masked study. *Eye* 7:584-590

Gartry DS 1993 Inleiding in de fotorefractieve keratectomie. *Visus* 8:4-7

O'Brart DPS, Gartry DS, Lohmann CP, Patmore AL, Kerr Muir MG, Marshall J Treatment of band keratopathy by excimer laser phototherapeutic keratectomy: surgical techniques and long term follow-up *Br J Ophthalmol* 77:702-708

Gartry DS, Kerr Muir MG, Marshall J 1993 Efficacy and long-term complications of excimer laser photorefractive keratectomy (PRK) - 3 year follow-up (Paper presented at ARVO, Sarasota, Florida, May 1993) *Invest Ophthalmol Vis Sci* 1993 34:892 (Abstract)

Gartry DS, Kerr Muir MG, Marshall J 1993 Photorefractive keratectomy - 18 month follow-up. *Mosby Yearbook of Ophthalmology*. C V Mosby, St Louis.

Gartry DS, Kerr Muir MG, Marshall J 1994 Efficacy and long-term complications of excimer laser photorefractive keratectomy (PRK): 4 year follow-up : an update *Eye on Meetings* 1:1

O'Brart DPS, Gartry DS, Lohmann CP, Kerr Muir MG, Marshall J 1994 Excimer laser photorefractive keratectomy for myopia: comparison of 4.00mm and 5.00mm ablation zones. *Refract Corneal Surg* 10: 87-94

Gartry DS 1995 Patient selection guidelines for photorefractive keratectomy (PRK) The British College of Optometrists - patient and practitioner guidelines

Gartry DS 1995 Excimer laser treatment of myopia - the present position (Fortnightly Review) Br Med Journal 310:979-985

Gartry DS 1995 Treatment of myopia with the excimer laser - is it really the bottom line? Ophthal Physiol Opt 15(Suppl 1):S2-S10

Gartry DS, Larkin DFP, Flaxel CJ, Ficker LA, Steele ADMcG Retreatment for significant regression following excimer laser photorefractive keratectomy (PRK) - a randomised, double-masked trial. Invest Ophthalmol Vis Sci 36:S190 (Paper presented at ARVO, Fort Lauderdale, Florida, May 1995)

Gartry DS 1995 The development of excimer laser corneal surgery. The proceedings of The Royal Institution of Great Britain (Discourse lecture, February 17th, 1995). (In press)