

THE 42 REDUCTS OF THE RANDOM ORDERED GRAPH

MANUEL BODIRSKY, MICHAEL PINSKER, AND ANDRÁS PONGRÁCZ

ABSTRACT. The *random ordered graph* is the up to isomorphism unique countable homogeneous linearly ordered graph that embeds all finite linearly ordered graphs. We determine the reducts of the random ordered graph up to first-order interdefinability.

1. INTRODUCTION

A famous result on infinite permutation groups, due to Cameron [Cam76], says that there are exactly five closed permutation groups on a countably infinite set D that are *highly set-transitive*, that is, for all finite $A, B \subseteq D$ of the same cardinality the groups contain a permutation sending A to B . This result is also famous in model theory, albeit in a different form: a relational structure Γ is a *reduct* of a structure Δ iff they have the same domain, and every relation of Γ has a first-order definition in Δ without parameters. For two structures Γ_1, Γ_2 , we set $\Gamma_1 \preceq \Gamma_2$ iff Γ_1 is a reduct of Γ_2 ; this defines a quasi-order on the set of all structures. We call two structures Γ_1, Γ_2 (*first-order*) *equivalent* iff $\Gamma_1 \preceq \Gamma_2$ and $\Gamma_2 \preceq \Gamma_1$. It can be shown (see Section 3.4 in [Cam90]) that Cameron's result on highly set-transitive permutation groups is equivalent to the fact that the order of the rationals $(\mathbb{Q}; <)$ has precisely five reducts up to equivalence. Interestingly, many other prominent homogeneous structures (see e.g. [Hod97]) have only finitely many inequivalent reducts: for instance the random graph [Tho91], the Henson graphs [Tho91], the random tournament [Ben97], the expansion $(\mathbb{Q}; <, 0)$ of $(\mathbb{Q}; <)$ by a constant [JZ08], and the random partial order [PPP⁺14].

Thomas [Tho91] conjectured that *every* countable homogeneous structure with a finite relational language has only finitely many inequivalent reducts. We know very little about this conjecture, beyond the fact that it is true for some fundamental homogeneous structures. When we factor the quasi-order \preceq of the reducts of such a homogeneous structure by equivalence, then the resulting order forms a lattice; we do not even know how to show that this lattice has only finitely many atoms, or no infinite ascending chains. In order to learn more, it seems to be unavoidable to verify the conjecture for more of the classical structures from model theory, independently from whether or not we believe the conjecture. Let us mention that apart from the intrinsic interest of this problem at the intersection of model theory and permutation group theory, there are other contexts in which the conjecture plays an interesting role: complexity classification in infinite-domain constraint satisfaction (see e.g. [BP11]), and minimal flows and universal minimal flows in topological dynamics (see Section 4.2 in [Tsa14]).

Date: November 9, 2018.

2010 Mathematics Subject Classification. Primary 20B27, 03C40; secondary 05C55, 03C10.

The first and third author have received funding from the European Research Council under the European Community's Seventh Framework Programme (FP7/2007-2013 Grant Agreement no. 257039).

The second author has been funded through project I836-N23 of the Austrian Science Fund (FWF) as well as through an APART fellowship of the Austrian Academy of Science.

There is an important construction to systematically produce new examples of homogeneous structures from old ones: suppose that Γ_1 and Γ_2 are two homogeneous structures with disjoint relational signatures τ_1 and τ_2 such that for each $i \in \{1, 2\}$ the class of all finite structures that embed into Γ_i has the strong amalgamation property (see e.g. [Cam90]). Then the class of all finite structures whose τ_1 -reduct¹ embeds into Γ_1 and whose τ_2 -reduct embeds into Γ_2 is a strong amalgamation class. It can be verified by a straightforward back-and-forth argument that the τ_i -reduct of the Fraïssé-limit Δ of this class is isomorphic to Γ_i (for an introduction to these basic concepts from model theory, see e.g. [Hod97]). We therefore call Δ the *(free) superposition* of Γ_1 and Γ_2 . The example we are concerned with in this paper is the *random ordered graph*, which is the free superposition of $(\mathbb{Q}; <)$ and the random graph, and denoted by $(D; <, E)$. By the above, the reduct $(D; <)$ of the random ordered graph is isomorphic to the order of the rationals, and the reduct $(D; E)$ to the random graph. We can thus interpret the construction of $(D; <, E)$ as one where we freely add the order of the rationals to the random graph $(D; E)$, and consequently could have called $(D; <, E)$ the *ordered random graph*.

In this article we present a complete classification of the reducts of the random ordered graph up to equivalence. Without counting the obvious reducts $(D; <, E)$ and $(D; =)$, there are precisely 42 such reducts (also see [Ada79]). This is the first time that the reducts of a free superposition of two homogeneous structures are determined.

There are several reasons why the random ordered graph is an interesting next candidate for verifying Thomas' conjecture. First of all, when Δ is the superposition of two homogeneous structures Γ_1 and Γ_2 , and when we know the reducts of Γ_1 and Γ_2 , we would like to be able to compute the reducts of Δ from this information. The superposition of $(\mathbb{Q}; <)$ and the random graph is one of the simplest examples of this type. While there are some reducts of $(D; <, E)$ that are indeed built from the reducts of $(\mathbb{Q}; <)$ and the reducts of the random graph in a systematic way, additional reducts appear in our classification. Moreover, there is a surprising asymmetry between the roles of $(\mathbb{Q}; <)$ and $(V; E)$ in the reduct lattice of the random ordered graph. It is probably fair to say that this shows that there is no general reduct classification result for superpositions. We remark that while we could have investigated the superposition of $(\mathbb{Q}; <)$ with itself or the random graph with itself, this would not have allowed us to discover the kind of asymmetry which we encounter in the present result. The reducts of the superposition of two copies of $(\mathbb{Q}; <)$ have been determined in subsequent work [LP14].

Another reason for studying the reducts of the random ordered graph is the technical dimension of this endeavor: when it comes to reduct classification, the complexity of this structure challenges the current methods. And indeed, not only the classifications of the reducts of $(\mathbb{Q}; <)$ and the random graph, but also the classification of the reducts of the random tournament [Ben97] appears as a subcase of our result, since the random tournament itself turns out to be a reduct of the random ordered graph.

In our classification proof, we apply a technique that is based on *Ramsey theory* and *canonical functions*; an introduction to this technique can be found in [BP11]. In the setting of the random ordered graph, the Ramsey-type result that we are going to employ is the well-known fact that the class of all finite linearly ordered graphs forms a Ramsey class (due to [AH78, NR83]; also see [NR89]). The strategy we apply here is generally applicable when the homogeneous structure under consideration has a expansion by finitely many relations

¹The τ -reduct of a $(\tau \cup \sigma)$ -structure Γ is the reduct of Γ with signature τ obtained from Γ by dropping the relations for the symbols from σ and keeping the relations for the symbols from τ .

which is homogeneous and whose class of finite induced substructures is a Ramsey class. We do not know of a single structure which is homogeneous in a finite relational signature and which does *not* have such an expansion. Therefore, arbitrary homogeneous structures in a finite relational language might well be within the scope of this method.

When applying the method in practice for the random ordered graph one faces a severe combinatorial explosion compared to previous classifications. Even though in principle parts of the classification could have been automated, the sheer number of cases is prohibitive for such a computer-aided approach. An important idea to keep the description of the reducts manageable is to identify and work with the *join-irreducible elements* of the reduct lattice. In previous situations where the same method has been applied, the size of the reduct lattice was so small that neither the advantage nor the possibility of reducing the work to the join irreducibles became visible.

Outline of the article. Section 2 is a catalog of the reducts of the random ordered graph. Section 3 gives an overview of the classification proof. Section 4 shows how to reduce the classification to those reducts that contain the relation $<$. Section 5 then classifies those. In Section 6 we verify that the reduct lattice is indeed as it has been drawn in Section 2.

2. THE REDUCT CATALOG

In this section we describe the reducts of the random ordered graph $(D; <, E)$. We write $\text{Aut}(\Gamma)$ for the set of automorphisms of a structure Γ . For reducts Γ_1, Γ_2 of the random ordered graph we have $\Gamma_1 \preceq \Gamma_2$ if and only if $\text{Aut}(\Gamma_1) \supseteq \text{Aut}(\Gamma_2)$. This holds more generally for ω -categorical structures, and is a consequence of the theorem of Engeler, Svenonius, and Ryll-Nardzewski (see, e.g., [Hod97]).

The permutations on a countable set X carry a natural topology, the *topology of pointwise convergence*: a set F of permutations of X is *closed* iff it contains every permutation g of X such that for every finite $S \subseteq X$ there exists an element $f \in F$ satisfying $f(x) = g(x)$ for all $x \in S$. Note that automorphism groups of structures are closed. Conversely, every closed group is the automorphism group of a relational structure. When F is a set of permutations, we write $\langle F \rangle$ for the smallest closed permutation group that contains F . The closed groups on a countable set form a lattice with respect to inclusion: for two such groups G_1 and G_2 , the *meet* $G_1 \wedge G_2$ of G_1 and G_2 is their intersection $G_1 \cap G_2$, whereas their *join* $G_1 \vee G_2$ is $\langle G_1 \cup G_2 \rangle$. From the above it follows that the poset \preceq of the reducts of an ω -categorical structure Δ up to equivalence is antiisomorphic to the lattice of closed groups containing $\text{Aut}(\Delta)$. In particular, it is itself a lattice. This lattice has a largest element, which is the equivalence class of Δ ; all other elements will be called the *proper* reducts of Δ . It also has a smallest element, the equivalence class of $(D; =)$, which will be called the *trivial* reduct.

We write \mathfrak{L} for the closed groups that contain $\text{Aut}(D; <, E)$. Since we are mostly taking the group-theoretic perspective, \mathfrak{L} is the lattice that we are going to work with in the following. The key to efficiently describe \mathfrak{L} is to first identify the *join irreducible elements* of \mathfrak{L} , that is, the closed groups G_0 that properly contain $\text{Aut}(D; <, E)$ and that have the property that whenever $G_0 = G_1 \vee G_2$ for $G_1, G_2 \in \mathfrak{L}$, then $G_0 = G_1$ or $G_0 = G_2$. We will prove that \mathfrak{L} has eleven join irreducibles, and that every element of \mathfrak{L} is a join of join irreducibles. From this it already follows that \mathfrak{L} is finite; by a finer study of the inclusions between the groups we prove that there are 42 proper non-trivial reducts of the random ordered graph.

The remainder of this section is organized as follows: we first recall the classical descriptions of the reducts of $(\mathbb{Q}; <)$ and the random graph in Subsection 2.1, since those descriptions appear as subclassifications of our result. It turns out that the random tournament is also a reduct of the random ordered graph. We recall the descriptions of the reducts of the random tournament, and then describe the groups that arise as intersections of automorphism groups of previously described reducts, in Subsection 2.2. All but three reducts of the random ordered graph have an automorphism group that arises in this way; those three ‘sporadic’ reducts are described in Subsection 2.3. Finally, we show a picture of \mathfrak{L} in Subsection 2.4.

2.1. Straightforward reducts. For $i \in \{1, 2\}$, let Γ_i be the Fraïssé-limit of two strong amalgamation classes, with signature τ_i and with n_i reducts up to equivalence. Then the superposition Δ of Γ_1 and Γ_2 has at least $n_1 n_2$ reducts up to equivalence, obtained in the following straightforward way. Recall that the τ_i -reduct of Δ is isomorphic to Γ_i , so we identify Γ_i with this reduct. Pick a reduct Γ'_1 of Γ_1 and a reduct Γ'_2 of Γ_2 , and consider the structure Γ with the same domain as Δ obtained by adding the relations from both Γ'_1 and Γ'_2 . Observe that the automorphism group of Γ equals $\text{Aut}(\Gamma'_1) \cap \text{Aut}(\Gamma'_2)$. It is clear that when in the above construction we replace Γ'_1 or Γ'_2 by an inequivalent reduct of Γ_1 or Γ_2 , respectively, then we obtain an inequivalent reduct of Δ .

Applying this to the random ordered graph, we obtain 25 inequivalent reducts. Among them we find in particular the reducts of $(\mathbb{Q}; <)$, and the reducts of the random graph, which we discuss next.

2.1.1. The reducts of $(\mathbb{Q}; <)$. Consider the structure obtained from $(\mathbb{Q}; <)$ by picking an irrational number π , and flipping the order between the intervals $(-\infty, \pi)$ and (π, ∞) . The resulting structure is isomorphic to $(\mathbb{Q}; <)$; write \circlearrowleft for such an isomorphism (a permutation of \mathbb{Q}). Write \leftrightarrow for the operation $x \mapsto -x$. The automorphism groups of the proper non-trivial reducts of $(\mathbb{Q}; <)$ can now be described as follows: there are $\langle \text{Aut}(\mathbb{Q}; <) \cup \{\leftrightarrow\} \rangle$, $\langle \text{Aut}(\mathbb{Q}; <) \cup \{\circlearrowleft\} \rangle$, and $\langle \text{Aut}(\mathbb{Q}; <) \cup \{\leftrightarrow, \circlearrowleft\} \rangle$. This follows from the result due to Cameron mentioned in the beginning of Section 1.

It will be useful later to also know relational descriptions of the reducts of $(\mathbb{Q}; <)$. Let *Betw*, *Cycl*, and *Sep* be the relations with the following definitions over $(\mathbb{Q}; <)$.

- $\text{Betw}(x, y, z) \Leftrightarrow ((x < y \wedge y < z) \vee (z < y \wedge y < x))$,
- $\text{Cycl}(x, y, z) \Leftrightarrow ((x < y \wedge y < z) \vee (y < z \wedge z < x) \vee (z < x \wedge x < y))$, and
- $\text{Sep}(x, y, u, v) \Leftrightarrow ((\text{Cycl}(x, y, u) \wedge \text{Cycl}(x, v, y)) \vee (\text{Cycl}(x, u, y) \wedge \text{Cycl}(x, y, v)))$.

The following is well-known (see e.g. [JZ08]):

- $\langle \text{Aut}(\mathbb{Q}; <) \cup \{\leftrightarrow\} \rangle = \text{Aut}(\mathbb{Q}; \text{Betw})$,
- $\langle \text{Aut}(\mathbb{Q}; <) \cup \{\circlearrowleft\} \rangle = \text{Aut}(\mathbb{Q}; \text{Cycl})$, and
- $\langle \text{Aut}(\mathbb{Q}; <) \cup \{\leftrightarrow, \circlearrowleft\} \rangle = \text{Aut}(\mathbb{Q}; \text{Sep})$.

2.1.2. The reducts of the random graph. The *random graph* is the up to isomorphism unique countable homogeneous graph $(V; E)$ that is *universal* in the sense that it contains all countable graphs as an induced subgraph. Equivalently, the random graph is the up to isomorphism unique countable graph with the following graph extension property (see [Hod97, Cam90]): for all disjoint finite subsets U_1, U_2 of V , there exists a vertex $v \in V \setminus (U_1 \cup U_2)$ that is connected to all vertices in U_1 and to none in U_2 .

To describe the reducts of the random graph $(V; E)$, it will again be more instructive to describe their automorphism groups. The complement graph of $(V; E)$ satisfies the graph extension property as well, and hence there exists an isomorphism between these two structures, a permutation of V we denote by $-$. Let $v \in V$. Consider the graph $(V; E')$ obtained from $(V; E)$ by ‘switching’ between edges and non-edges on all pairs (u, v) with $u \in V \setminus \{v\}$. That is, if $(u, v) \in E$ then $(u, v) \notin E'$, and if $(u, v) \notin E$ then $(u, v) \in E'$. For all $u, u' \in V \setminus \{v\}$ we have $(u, u') \in E$ if and only if $(u, u') \in E'$. Then $(V; E')$ also satisfies the graph extension property, and hence there exists an isomorphism between $(V; E)$ and $(V; E')$, which we denote by sw . Now the automorphism groups of the non-trivial reducts of $(V; E)$ are $\langle \text{Aut}(V; E) \cup \{-\} \rangle$, $\langle \text{Aut}(V; E) \cup \{\text{sw}\} \rangle$, and $\langle \text{Aut}(V; E) \cup \{-, \text{sw}\} \rangle$. This result is due to Thomas [Tho91].

Again, we present relational descriptions of those groups. For $k \geq 2$, let $R^{(k)}$ be the k -ary relation that contains all k -tuples of pairwise distinct elements x_1, \dots, x_k in V such that the number of (undirected) edges between those elements is odd. The following is well-known (see [Tho96]).

- $\langle \text{Aut}(V; E) \cup \{-\} \rangle = \text{Aut}(V; R^{(4)})$,
- $\langle \text{Aut}(V; E) \cup \{\text{sw}\} \rangle = \text{Aut}(V; R^{(3)})$, and
- $\langle \text{Aut}(V; E) \cup \{-, \text{sw}\} \rangle = \text{Aut}(V; R^{(5)})$.

2.2. Coupled reducts. Consider the reduct of the random ordered graph that contains the binary relation T defined over $(D; <, E)$ by the formula

$$x \neq y \wedge (x < y \Leftrightarrow E(x, y)) .$$

The reduct $(D; T)$ is isomorphic to the *random tournament*, defined below, and it is straightforward to show that the automorphism group of $(D; T)$ is *not* an intersection of automorphism groups of reducts of $(D; <)$ or reducts of $(D; E)$. The reducts of the random tournament have been classified by Bennett [Ben97], and in Subsection 2.2.1 we give a brief description of those reducts. In Subsection 2.2.2 we give an operational description of those groups that arise as intersections of automorphism groups of reducts of $(D; <)$, $(D; E)$, or $(D; T)$.

2.2.1. The reducts of the random tournament. A *tournament* is a directed graph such that for all distinct vertices u, v exactly one of (u, v) and (v, u) is an edge of the graph. In the following, we will use basic concepts from model theory, as they are used e.g. in [Hod97]. The class of all finite tournaments forms an amalgamation class, and the corresponding Fraïssé-limit will be called the *random tournament*. The random tournament is the up to isomorphism unique countable tournament with the following tournament extension property: for all finite subsets U_1, U_2 of vertices, there exists a vertex $v \notin U_1 \cup U_2$ such that (u, v) is an edge for all $u \in U_1$, and (v, u) is an edge for all $u \in U_2$. It is straightforward to verify that the relation $T(x, y)$ defined by $x \neq y \wedge (x < y \Leftrightarrow E(x, y))$ over $(D; <, E)$ satisfies the tournament extension property. Thus, the random tournament is (isomorphic to) the reduct $(D; T)$ of $(D; <, E)$.

The tournament obtained by *flipping* the orientation of all edges again satisfies the tournament extension property; we denote the isomorphism by \rightleftharpoons . The tournament obtained by flipping the orientation of all edges that are adjacent to some fixed vertex satisfies the tournament extension property; denote by tsw the respective permutation of D . Then the automorphism groups of the non-trivial reducts of $(D; T)$ are: $\langle \text{Aut}(D; T) \cup \{\rightleftharpoons\} \rangle$, $\langle \text{Aut}(D; T) \cup \{\text{tsw}\} \rangle$, and $\langle \text{Aut}(D; T) \cup \{\rightleftharpoons, \text{tsw}\} \rangle$. This result is due to Bennet [Ben97].

Name	a	b	c	d	e	f
Description	$\langle\langle \text{id} \rangle_{\leftrightarrow}\rangle$	$\langle\langle \text{id} \rangle_{\circlearrowleft}\rangle$	$\langle\langle - \rangle_{\text{id}}\rangle$	$\langle\langle \text{sw} \rangle_{\text{id}}\rangle$	$\langle\langle - \rangle_{\leftrightarrow}\rangle$	$\langle\langle \text{sw} \rangle_{\circlearrowleft}\rangle$

FIGURE 1. Join irreducible elements of \mathfrak{L} generated by coupled operations introduced in Section 2.2.2

Let Betw_T be the ternary relation with the following first-order definition over T .

$$\text{Betw}_T(x, y, z) \Leftrightarrow (T(x, y) \wedge T(y, z) \wedge T(z, x)) \vee (T(z, y) \wedge T(y, x) \wedge T(x, z))$$

Define the ternary relation Cycl_T by

$$\begin{aligned} \text{Cycl}_T(x, y, z) \Leftrightarrow & ((T(x, y) \wedge T(y, z) \wedge T(z, x)) \\ & \vee (T(x, z) \wedge T(z, y) \wedge T(x, y)) \\ & \vee (T(y, x) \wedge T(x, z) \wedge T(y, z)) \\ & \vee (T(z, y) \wedge T(y, x) \wedge T(z, x))) \end{aligned}$$

Finally, let Sep_T be the relation of arity four that contains all tuples $(x, y, u, v) \in D^4$ such that $|\{T \cap (\{x, y\} \times \{u, v\})\}|$ is even. It is clear that also Sep_T is first-order definable over $(D; T)$.

The following is a consequence of Bennett’s classification.

- $\langle \text{Aut}(\mathbb{Q}; T) \cup \{\Leftarrow\} \rangle = \text{Aut}(\mathbb{Q}; \text{Betw}_T)$,
- $\langle \text{Aut}(\mathbb{Q}; T) \cup \{\text{tsw}\} \rangle = \text{Aut}(\mathbb{Q}; \text{Cycl}_T)$, and
- $\langle \text{Aut}(\mathbb{Q}; T) \cup \{\Leftarrow, \text{tsw}\} \rangle = \text{Aut}(\mathbb{Q}; \text{Sep}_T)$.

2.2.2. Reducts from coupling operations. In this section we will define some more reducts by constructing permutations of D that, intuitively, combine the behavior of \circlearrowleft , \leftrightarrow , and the identity with the behavior of sw , $-$, and the identity in various ways. In the following we exclusively work with groups that contain $\text{Aut}(D; <, E)$. For this reason, and in order to be concise, we write $\langle F \rangle$ instead of $\langle F \cup \text{Aut}(D; <, E) \rangle$.

Consider the structure obtained from $(D; <, E)$ by flipping simultaneously edges with non-edges and the order. The resulting structure is isomorphic with $(D; <, E)$; let $\langle - \rangle_{\circlearrowleft}$ be an isomorphism witnessing this fact. Similarly, the structure obtained by flipping edges with non-edges whilst keeping the order is isomorphic to $(D; <, E)$; let $\langle - \rangle_{\text{id}}$ be an isomorphism witnessing this fact. We furthermore define in an analogous fashion permutations $\langle \text{id} \rangle_{\leftrightarrow}$, $\langle \text{id} \rangle_{\circlearrowleft}$, and $\langle \text{sw} \rangle_{\text{id}}$. Slightly less obvious is “coupling” sw with \circlearrowleft : Pick an irrational π , and consider the structure obtained by flipping edges and non-edges which cross π , as well as flipping the order between the intervals $(-\infty, \pi)$ and (π, ∞) . The resulting structure is isomorphic to $(D; <, E)$, and we pick an isomorphism $\langle \text{sw} \rangle_{\circlearrowleft}$ witnessing this.

With the relational descriptions of the reducts of $(\mathbb{Q}; <)$, of the random graph, and of the random tournament it is straightforward to show that these operations do not generate each other. In Figure 1 we introduce names for the groups generated by each of these operations; it will turn out that these groups are join irreducible in \mathfrak{L} . In fact, we will later see that the groups a, b, c, d, e and f are precisely the *atoms* of \mathfrak{L} , that is, every closed group properly containing $\text{Aut}(D; <, E)$ contains at least one of a, b, c, d, e, f . The remaining join irreducible elements of \mathfrak{L} will be defined in Section 2.3 and listed in Figure 2.

g	h	i	j	k	Name
$\langle\langle \binom{l}{\text{id}} \rangle\rangle$	$\langle\langle \binom{u}{\text{id}} \rangle\rangle$	$\text{Aut}(D; E)$	$\text{Aut}(D; <)$	$\text{Aut}(D; T)$	Description

FIGURE 2. The remaining join irreducible elements of \mathfrak{L} , including some sporadic ones introduced in Section 2.3

At this point, one is tempted to conjecture that all the reducts of the random ordered graph are obtained from reducts of $(D; <)$, $(D; E)$, and $(D; T)$ by combining the relations from those reducts in all possible ways. Indeed, all reducts that we have encountered so far can be obtained in this form. However, as we will see in the following, there are more reducts.

2.3. Sporadic Reducts. Let $\binom{l}{\text{id}}$ be a permutation of D that preserves $<$ and switches the graph relation below some irrational π , and leaves it unaltered otherwise. Analogously, let $\binom{u}{\text{id}}$ be a permutation which preserves $<$ and switches the graph relation above π . To show that the corresponding reducts are pairwise distinct, and also distinct from all the previous reducts, we make the following definitions.

$$R_3^l := \{(a_1, a_2, a_3) \mid a_1 < a_2 < a_3 \text{ and } E(a_1, a_3) \Leftrightarrow E(a_2, a_3)\}$$

$$R_3^u := \{(a_1, a_2, a_3) \mid a_1 < a_2 < a_3 \text{ and } E(a_1, a_3) \Leftrightarrow E(a_1, a_2)\}$$

It will be shown in Section 5.1.2 that $\langle\langle \binom{l}{\text{id}} \rangle\rangle = \text{Aut}(D; R_3^l)$, and $\langle\langle \binom{u}{\text{id}} \rangle\rangle = \text{Aut}(D; R_3^u)$.

In Figure 2, we assign names to the remaining join irreducibles of \mathfrak{L} , including the groups we just defined.

2.4. The big picture. The main result of the paper is the following.

Theorem 1. *The random ordered graph $(D; <, E)$ has exactly 42 proper non-trivial reducts up to equivalence.*

As discussed before, this is equivalent to the statement that there are 44 closed permutation groups that contain the automorphism group of the random ordered graph.

The Hasse diagram of the lattice \mathfrak{L} of those groups is as depicted in Figure 3. In this figure, the bottom vertex denotes $\text{Aut}(D; <, E)$. All other vertices are labeled with the set of maximal join irreducibles below them. For instance, the vertex labeled dgh lies above c, d, g, h , with d, g, h maximal; and it can be variously defined as $d \vee g, d \vee h$, or $g \vee h$.

The verification that the lattice indeed has the shape that is presented in Figure 3 will be completed in Section 6.

Note that the groups from Section 2.3, labeled ‘g’, ‘h’, and ‘dgh’ in the picture, show that \mathfrak{L} is not symmetric with respect to the roles of $(D; <)$ and $(D; E)$, that is, there is no automorphism of \mathfrak{L} sending $\text{Aut}(D; <)$ to $\text{Aut}(D; E)$.

3. OVERVIEW OF THE PROOF

The main part of our proof identifies the join irreducible elements of \mathfrak{L} , and shows that every closed group containing $\text{Aut}(D; <, E)$ is the join of such join irreducibles.

Definition 2. We set $\Delta := (D; <, E)$. Let JI be the set of those groups which were given a name in $\{a, \dots, k\}$ in the previous section (Figures 1 and 2):

- the “small” groups $\langle\langle \binom{\text{id}}{\circ} \rangle\rangle, \langle\langle \binom{\text{sw}}{\circ} \rangle\rangle, \langle\langle \binom{\text{id}}{\leftrightarrow} \rangle\rangle, \langle\langle \binom{-}{\leftrightarrow} \rangle\rangle, \langle\langle \binom{\text{sw}}{\text{id}} \rangle\rangle, \langle\langle \binom{-}{\text{id}} \rangle\rangle$;

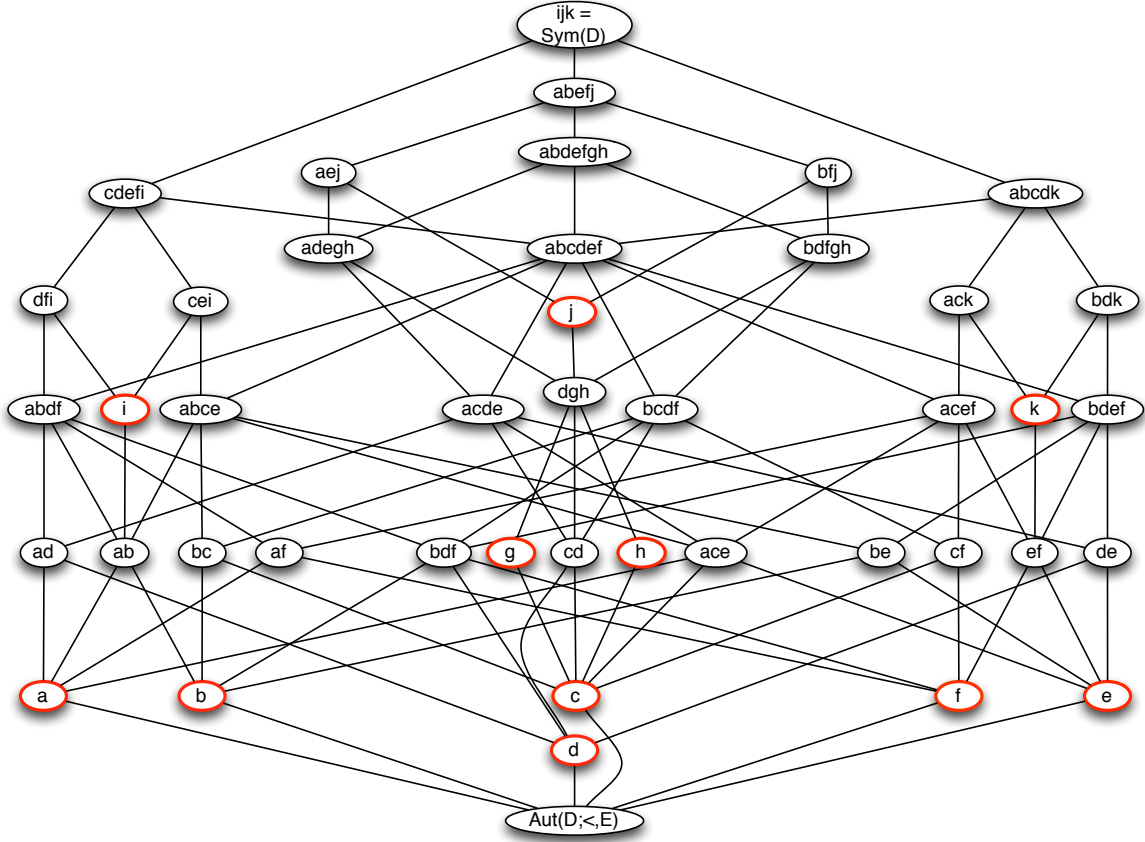

FIGURE 3. The lattice \mathfrak{L} of closed supergroups of $\text{Aut}(D; <, E)$.

- the “medium-sized” groups $\langle\langle \text{id}^l \rangle\rangle$ and $\langle\langle \text{id}^u \rangle\rangle$;
- the “large” groups $\text{Aut}(D; <)$, $\text{Aut}(D; E)$, $\text{Aut}(D; T)$.

It will turn out that the groups of **JI** are precisely the join irreducibles of \mathfrak{L} . In Sections 4 and 5 we will obtain the following statement.

Proposition 3. *Let $G, H \supseteq \text{Aut}(\Delta)$ be closed groups such that $H \setminus G \neq \emptyset$. Then there exists an element of **JI** which is contained in H but not in G .*

From this we immediately get

Corollary 4. *Every closed group containing $\text{Aut}(\Delta)$ is the join of elements of **JI**.*

Proof. Let H be a closed group containing $\text{Aut}(\Delta)$, and let G be the join of all elements of **JI** which are contained in H . By Proposition 3 we must have $H \setminus G = \emptyset$, so $H = G$. \square

It follows that $|\mathfrak{L}| \leq 2^{|\text{JI}|}$, and in particular that \mathfrak{L} is finite. To obtain a full proof of our classification, it remains to show for all $G \in \text{JI}$ and all subsets \mathcal{S} of **JI** that $G \subseteq \bigvee \mathcal{S}$ if and only if it has been drawn that way in the picture. We postpone this task to Section 6, and first concentrate on the mathematically more interesting and challenging proof

of Proposition 3. This proof will be obtained by a Ramsey-theoretic analysis of functions on Δ , and follows [BPT13, BP, BP14, BP11]. Before starting out, we provide the necessary definitions for this analysis.

Definition 5. Let Λ be a structure. The *type* $\text{tp}(a)$ of an n -tuple a of elements in Λ is the set of first-order formulas with free variables x_1, \dots, x_n that hold for a in Λ .

Definition 6. Let Λ, Ω be structures. A *type condition* between Λ and Ω is a pair (t, s) , where t is a type of an n -tuple in Λ , and s is a type of an n -tuple in Ω , for some $n \geq 1$.

A function $f: \Lambda \rightarrow \Omega$ *satisfies* a type condition (t, s) between Λ and Ω iff for all n -tuples $a = (a_1, \dots, a_n)$ of elements of Λ with $\text{tp}(a) = t$ the n -tuple $f(a) := (f(a_1), \dots, f(a_n))$ has type s in Ω . A *behavior* is a set of type conditions between structures Λ and Ω . A function from Λ to Ω *satisfies a behavior* B iff it satisfies all the type conditions of B .

Definition 7. Let Λ, Ω be structures. A function $f: \Lambda \rightarrow \Omega$ is *canonical* iff for all types t of n -tuples in Λ there exists a type s of n -tuples in Ω such that f satisfies the type condition (t, s) . In other words, n -tuples of equal type in Λ are sent to n -tuples of equal type in Ω under f , for all $n \geq 1$.

Note that for a canonical function $f: \Lambda \rightarrow \Omega$, the set of all type conditions satisfied by f is a function from the types over Λ to the types over Ω .

Definition 8. For a set F of functions from D to D , we denote by \overline{F} the closure of F in D^D , i.e., the set of all functions in D^D which agree with some function in F on every finite subset of D .

Definition 9. We say that a set $S \subseteq D^D$ *generates a function* $f \in D^D$ *over* Δ iff f is contained in the smallest closed monoid containing $S \cup \text{Aut}(\Delta)$; equivalently, f is contained in the closure of the set of all functions that can be composed from S and $\text{Aut}(\Delta)$. Since we will only be interested in sets of functions containing $\text{Aut}(\Delta)$, we will say “generates” rather than “generates over Δ ”.

The combinatorial kernel of our method is the following proposition which follows from [BPT13, BP11] and the fact that the set of finite linearly ordered graphs is a *Ramsey class* (due to [AH78, NR83]; [NR89]). It states that if a function on Δ does something of interest on a finite set, then it produces a canonical function which still does the same thing. For $c_1, \dots, c_n \in D$ we denote by $(\Delta, c_1, \dots, c_n)$ the structure obtained from Δ by adding the constants c_1, \dots, c_n to the language.

Proposition 10. *Let $f: D \rightarrow D$ be a function, and let $c_1, \dots, c_n \in D$. Then*

$$\overline{\{\alpha \circ f \circ \beta \mid \alpha \in \text{Aut}(\Delta), \beta \in \text{Aut}(\Delta, c_1, \dots, c_n)\}}$$

contains a function g such that

- *g is canonical as a function from $(\Delta, c_1, \dots, c_n)$ to Δ ;*
- *g agrees with f on $\{c_1, \dots, c_n\}$.*

In particular, f generates a function g with these properties.

It follows that we can distinguish the elements of \mathfrak{L} by canonical functions, as follows (see [BPT13, BP11]).

Proposition 11. *Let $G, H \supseteq \text{Aut}(\Delta)$ be closed groups such that $H \setminus G \neq \emptyset$. Then there exist $c_1, \dots, c_n \in D$ and a function $f: D \rightarrow D$ such that*

- f is canonical as a function from $(\Delta, c_1, \dots, c_n)$ to Δ ;
- f is generated by H but not by G .

In Section 5, we will prove that if $G, H \supseteq \text{Aut}(\Delta)$ are closed groups such that $H \setminus G \neq \emptyset$, then there exists a group in JI which is contained in H but not in G , or the function f of Proposition 11 can be assumed to preserve the order $<$. This is achieved in Proposition 12. In Section 6 we show that in the latter situation, we also find an element of JI which is contained in H but not in G (Proposition 29). This completes the proof of Proposition 3.

4. THE UNORDERED CASE

The goal of this section is the following

Proposition 12. *Let $G, H \supseteq \text{Aut}(\Delta)$ be closed groups such that $H \setminus G \neq \emptyset$. Then one of the following holds:*

- There exists an element of JI which is contained in H but not in G ;
- there exist $c_1, \dots, c_n \in D$ and an order preserving canonical function $f: (\Delta, c_1, \dots, c_n) \rightarrow \Delta$ which is generated by H but not by G .

We will prove this proposition by analyzing possible behaviors of canonical functions guaranteed by Proposition 11. To this end, let us introduce some notation and terminology.

Definition 13. We define a binary relation $N(x, y)$ on D by the formula $\neg E(x, y) \wedge x \neq y$.

Definition 14. Let $f: D \rightarrow D$ be injective, and let $X, Y \subseteq D$. We say that f

- preserves a relation $R(x_1, \dots, x_n)$ on X iff $R(x_1, \dots, x_n)$ implies $R(f(x_1), \dots, f(x_n))$ for all $x_1, \dots, x_n \in X$;
- reverses the order on X iff $x < y$ implies $f(x) > f(y)$ for all $x, y \in X$;
- keeps the graph relation on X iff $E(x, y) \leftrightarrow E(f(x), f(y))$ for all $x, y \in X$;
- flips the graph relation on X iff $E(x, y) \leftrightarrow N(f(x), f(y))$ for all $x, y \in X$;
- eradicates edges on X iff $N(f(x), f(y))$ for all $x, y \in X$;
- eradicates non-edges on X iff $E(f(x), f(y))$ for all $x, y \in X$;
- preserves a relation $R(x, y)$ between X, Y iff $R(x, y)$ implies $R(f(x), f(y))$ for all $x \in X$ and $y \in Y$;
- reverses the order between X, Y iff $x < y$ implies $f(x) > f(y)$ for all $x \in X$ and $y \in Y$;
- keeps the graph relation between X, Y iff $E(x, y) \leftrightarrow E(f(x), f(y))$ for all $x \in X$ and $y \in Y$;
- flips the graph relation between X, Y iff $E(x, y) \leftrightarrow N(f(x), f(y))$ for all $x \in X$ and $y \in Y$;
- eradicates edges between X, Y iff $N(f(x), f(y))$ for all $x \in X$ and $y \in Y$;
- eradicates non-edges between X, Y iff $E(f(x), f(y))$ for all $x \in X$ and $y \in Y$.

Definition 15. Let $c_1, \dots, c_n, d \in D$ be distinct. The *level* of d in $(\Delta, c_1, \dots, c_n)$ is the number of c_i below d . For $0 \leq i \leq n$ we call the set of all $d \in D \setminus \{c_1, \dots, c_n\}$ which are on level i the *i -th level* of $(\Delta, c_1, \dots, c_n)$.

Definition 16. Let Ω be a structure. Then any set of the form $\{\alpha(x) : \alpha \in \text{Aut}(\Omega)\}$, where x is an element of the domain of Ω , is called an *orbit* of Ω .

Note that if $c_1, \dots, c_n \in D$ and X is an orbit of $(\Delta, c_1, \dots, c_n)$, then all elements of X are on the same level, which we will call the level of X . Observe also that X induces a copy of Δ .

Definition 17. For subsets X, Y of D we write $X < Y$ iff $x < y$ for all $x \in X$ and all $y \in Y$. We write $X > Y$ iff $Y < X$.

4.1. Possible behaviors.

Lemma 18. Let $c_1, \dots, c_n \in D$, let $f: (\Delta, c_1, \dots, c_n) \rightarrow \Delta$ be canonical, and let X be an infinite orbit of $(\Delta, c_1, \dots, c_n)$. Then f preserves the order on X , or it reverses the order on X .

Proof. Pick $x, y \in X$ with $x < y$ and $E(x, y)$. Assume that $f(x) < f(y)$. Pick $z \in X$ such that $y < z$, $E(y, z)$, and $N(x, z)$. Then since f is canonical and $f(x) < f(y)$ we must have $f(y) < f(z)$, and hence $f(x) < f(z)$. Now if $u, v \in X$ with $u < v$ are arbitrary, then $f(u) < f(v)$ is implied by $f(x) < f(y)$ in case $E(u, v)$, and by $f(x) < f(z)$ in case $N(u, v)$ holds. Hence, f preserves the order on X . Dually, we can derive that f is order reversing on X when $f(x) > f(y)$. \square

Lemma 19. Let $c_1, \dots, c_n \in D$ and let $f: (\Delta, c_1, \dots, c_n) \rightarrow \Delta$ be canonical. Let X, Y be orbits of $(\Delta, c_1, \dots, c_n)$ on the same level, and assume that neither $f[X] < f[Y]$ nor $f[X] > f[Y]$ holds. Then either f preserves the order on $X \cup Y$, or it reverses the order on $X \cup Y$.

Proof. By Lemma 18, f preserves or reverses the order on X and Y . Assuming it preserves the order on X , we show that it preserves the order on $X \cup Y$; the order reversing case is dual. Suppose that $x \in X$, $y \in Y$, $x < y$ and $E(x, y)$ imply $f(x) > f(y)$. Then for arbitrary $u \in X$ and $v \in Y$ we can pick $x \in X$ with $x < u$, $x < v$, and $E(x, v)$. By our assumption, we then have $f(x) > f(v)$, and moreover $f(u) > f(x) > f(v)$ since f is order preserving on X . Hence, $f[X] > f[Y]$, a contradiction. We therefore conclude that $x \in X$, $y \in Y$, $x < y$ and $E(x, y)$ imply $f(x) < f(y)$; by duality, $x \in X$, $y \in Y$, $x < y$ and $N(x, y)$ imply $f(x) < f(y)$ as well, and so $x \in X$, $y \in Y$ and $x < y$ imply $f(x) < f(y)$.

Suppose that f reverses the order on Y . Then the dual argument of the argument above shows that $x \in X$, $y \in Y$ and $x > y$ imply $f(x) < f(y)$. But then putting together our information we have $f[X] < f[Y]$, a contradiction. Hence, f preserves the order on Y . Then the argument above shows that $x \in X$, $y \in Y$ and $x > y$ imply $f(x) > f(y)$, and so f preserves the order on $X \cup Y$, proving the lemma. \square

4.2. Compactness and eradicating structure. We will need some general facts that are often needed in the investigation of reducts of homogeneous structures. We chose to formulate them not only for Δ to emphasize their generality. The first statement can be proven by a standard compactness argument.

Lemma 20. Let Ω be an ω -categorical structure with domain D , and let T be a set of finite partial functions with the following properties:

- T is closed under restrictions;
- every finite subset of D is the domain of some function in T ;
- whenever $p \in T$ and $\alpha \in \text{Aut}(\Omega)$, then $\alpha \circ p \in T$.

Let $F \subseteq D^D$ be so that every $p \in T$ is the restriction of some $f \in F$. Then

$$\overline{\{\alpha \circ f \mid \alpha \in \text{Aut}(\Omega), f \in F\}}$$

contains a function $g: D \rightarrow D$ such that every restriction of g to a finite set belongs to T .

Corollary 21. *Let $G \supseteq \text{Aut}(\Delta)$ be a closed group, and assume that G generates for every finite $A \subseteq D$ a function $f: D \rightarrow D$ which eradicates edges or non-edges on A . Then G generates a canonical function $g: D \rightarrow D$ which eradicates edges or non-edges.*

Proof. By Lemma 20, G generates a function $h: D \rightarrow D$ which eradicates edges or non-edges. By Proposition 10,

$$\overline{\{\alpha \circ h \circ \beta \mid \alpha, \beta \in \text{Aut}(\Delta)\}}$$

contains a canonical function; clearly, this function still eradicates edges or non-edges. \square

4.3. Moving above $\text{Aut}(D; <)$.

Lemma 22. *Let $G \supseteq \text{Aut}(\Delta)$ be a closed group, and assume it generates for every finite $A \subseteq D$ a function $f: D \rightarrow D$ which eradicates edges or non-edges on A . Then $G \supseteq \text{Aut}(D; <)$.*

Proof. By Lemma 18 and Corollary 21, G generates an order preserving or order reversing function $e: D \rightarrow D$ which eradicates edges or non-edges on D . Replacing e by e^2 , we then have that e preserves the order. Let Γ be a reduct of Δ whose automorphism group equals G , and let Γ' be the structure induced by $e[D]$ in Γ . Because Δ has quantifier elimination, the restriction of any formula over Δ to $e[D]$ is equivalent to a formula over $(D; <)$. Hence, Γ' is definable in $(e[D]; <)$. Since e^{-1} is an isomorphism from Γ' onto Γ as well as from $(e[D]; <)$ to $(D; <)$, Γ is definable in $(D; <)$, and so its automorphism group G contains $\text{Aut}(D; <)$. \square

Lemma 23. *Let $G \supseteq \text{Aut}(\Delta)$ be a closed group, and assume it generates a canonical function $f: (\Delta, c_1, \dots, c_n) \rightarrow \Delta$, where $c_1, \dots, c_n \in D$, which eradicates edges or non-edges on an infinite orbit of $(\Delta, c_1, \dots, c_n)$. Then $G \supseteq \text{Aut}(D; <)$.*

Proof. Let X be an infinite orbit on which f eradicates edges or non-edges. The structure induced by X is isomorphic to Δ . Hence, any tuple of elements of D can be sent into X by an automorphism of Δ , and the claim follows from Lemma 22. \square

Lemma 24. *Let $G \supseteq \text{Aut}(\Delta)$ be a closed group, let $c_1, \dots, c_n \in D$, and let $f: (\Delta, c_1, \dots, c_n) \rightarrow \Delta$ be a canonical function generated by G . If there exist infinite orbits X, Y of $(\Delta, c_1, \dots, c_n)$ such that f eradicates edges or non-edges between X and Y , then $G \supseteq \text{Aut}(D; <)$.*

Proof. If f eradicates edges or non-edges on X or Y then we are done by Lemma 23, so we may assume that it keeps or flips the graph relation on X and Y .

Case 1. f keeps the graph relation on both X and Y . Let $A \subseteq D$ be finite. If there exist $a, a' \in A$ with $E(a, a')$, then let $\alpha \in \text{Aut}(\Delta)$ be so that $\alpha[A] \subseteq X \cup Y$ and such that $\alpha(a) \in X$ iff $\alpha(a') \in Y$. Then $f \circ \alpha[A]$ has less edges than A , and so the iteration of this process allows us to send A to an independent set. The statement now follows from Lemma 22.

Case 2. f flips the graph relation on both X and Y . We may assume that $f[D] \subseteq Y$. Then replacing f by f^2 brings us back to Case 1.

Case 3. f flips the graph relation on precisely one of the sets X and Y , say without loss of generality on X . If f preserves $<$ between X and Y and between Y and X , then we may assume $f[X] \subseteq X$ and $f[Y] \subseteq Y$; replacing f by f^2 then brings us back to Case 1. Otherwise we may assume $f[Y] \subseteq X$ and $f[X] \subseteq Y$; replacing f by f^2 then brings us back to Case 2. \square

4.4. Moving above $\text{Aut}(D; <)$ or turns.

Lemma 25. *Let $G \supseteq \text{Aut}(\Delta)$ be a closed group, and let $c_1, \dots, c_n \in D$. Assume G generates a canonical function $f: (\Delta, c_1, \dots, c_n) \rightarrow \Delta$ such that for two infinite orbits X, Y of*

$(\Delta, c_1, \dots, c_n)$ with $X < Y$ we have $f[X] > f[Y]$, and such that f is order preserving on either X or Y . Then G contains $\binom{\text{id}}{\circlearrowleft}$, $\binom{\text{sw}}{\circlearrowleft}$, or $\text{Aut}(D; <)$.

Proof. If f eradicates edges or non-edges on X , on Y , or between X and Y , then we are done by Lemmas 23 and 24; therefore, we may assume that f keeps or flips the graph relation on X , on Y , and between X and Y . Say without loss of generality that f is order preserving on X . If it flips the graph relation on X , then it generates $\binom{\bar{\text{id}}}{\circlearrowleft}$, and replacing f by $\binom{\bar{\text{id}}}{\circlearrowleft} \circ f$ gives us a function which keeps the graph relation on X . Now let $a_1, \dots, a_k \in D$ be arbitrary, and assume without loss of generality $a_1 < \dots < a_k$. Let $\alpha \in \text{Aut}(\Delta)$ be so that it sends a_1, \dots, a_{k-1} into X and a_k into Y . Set $g := f \circ \alpha$. Then $g(a_k) < g(a_1) < \dots < g(a_{k-1})$. If f keeps the graph relation between X and Y , this shows that we can change the order between the a_i cyclically without changing the graph relation by repeated applications of f and automorphisms of Δ , and so f generates $\binom{\text{id}}{\circlearrowleft}$. Otherwise, it flips the graph relation between X and Y , and hence application of g flips the graph relation between a_k and the other a_i . This shows that we can change the order between the a_i cyclically by repeated applications of f and automorphisms of Δ in such a way that the graph relation changes between a_i and a_j whenever the order changes, and so f generates $\binom{\text{sw}}{\circlearrowleft}$. \square

4.5. Moving above $\text{Aut}(D; <)$, $\text{Aut}(D; E)$, or $\text{Aut}(D; T)$.

Lemma 26. *Let $G \supseteq \text{Aut}(\Delta)$ be a closed group. Assume that it generates a canonical function $f: (\Delta, c) \rightarrow \Delta$ such that f is order preserving on and between the infinite orbits of (Δ, c) , and such that $f(c) > f(v)$ for all $v \in D \setminus \{c\}$. Then G contains $\text{Aut}(D; <)$, $\text{Aut}(D; E)$, or $\text{Aut}(D; T)$.*

Proof. By Lemmas 23 and 24, we may assume that f keeps or flips the graph relation on every infinite orbit and between any two infinite orbits. Since f is order preserving on and between the infinite orbits, it is easy to see that there exists a self-embedding e of Δ such that $(e \circ f)[X] \subseteq X$ for every infinite orbit X of (Δ, c) . Replacing f by $e \circ f$, we henceforth assume that f itself has this property. Setting $g := f^2$, we then have:

- g is canonical as a function from (Δ, c) to Δ ;
- $g(c) \geq g(v)$ for all $v \in D$, and g is order preserving on and between the infinite orbits of (Δ, c) ;
- $(g(x), g(y)) \in E$ iff $(x, y) \in E$ for all $x, y \in D \setminus \{c\}$.

Suppose that g eradicates edges between $\{c\}$ and level 1. Let $a_1, \dots, a_n \in D$, and say without loss of generality $a_1 < \dots < a_n$. Let $\alpha \in \text{Aut}(\Delta)$ be so that $\alpha(a_1) = c$, and set $h := g \circ \alpha$. Then $N(h(a_1), h(a_i))$ for all $2 \leq i \leq n$, and otherwise E and N are preserved between the a_i under h . Moreover, $h(a_2) < \dots < h(a_n) < h(a_1)$. Iterating this process, we can send the a_i to an independent set, and so Lemma 22 implies that G contains $\text{Aut}(D; <)$. The same argument works when g eradicates edges between $\{c\}$ and level 0, and the dual argument works when g eradicates non-edges between $\{c\}$ and an entire level.

Case 1. g preserves E and N . Then for any $a_1, \dots, a_n \in D$ there is h generated by g such that $h(a_1) < \dots < h(a_n)$. Since h preserves E and N we have $G \supseteq \text{Aut}(D; E)$.

Case 2. g flips E and N between c and $D \setminus \{c\}$. By composing g with a self-embedding of Δ we can achieve $g(c) = c$ while keeping the properties listed above. Then g^2 preserves E and N and we are back in the preceding case.

Case 3. g flips E and N between c and level 1, and preserves E and N between c and level 0. We will show that G contains $\text{Aut}(D; T)$. Let $a_1, \dots, a_n, b_1, \dots, b_n \in D$ be so that the

mapping ξ which sends every a_i to b_i is an isomorphism with respect to the structures which $\{a_1, \dots, a_n\}$ and $\{b_1, \dots, b_n\}$ induce in $(D; T)$. Say without loss of generality $a_1 < \dots < a_n$, and write $b_{j_1} < \dots < b_{j_n}$. Let $\alpha_1 \in \text{Aut}(\Delta)$ send a_{j_1} to c , and set $h_1 := g \circ \alpha_1$. Let $\alpha_2 \in \text{Aut}(\Delta)$ send $h_1(a_{j_2})$ to c , and set $h_2 := g \circ \alpha_2 \circ h_1$. Continue like this, arriving at $h := h_n$. We then have that $h(a_{j_1}) < \dots < h(a_{j_n})$. Moreover, under h edges and non-edges are flipped between elements a_i, a_j if and only if the order is flipped between these elements. Hence, h restricted to $\{a_1, \dots, a_n\}$ is an isomorphism between induced substructures of $(D; T)$. It follows that the mapping which sends every $h(a_{j_i})$ to b_{j_i} is a partial isomorphism on Δ . Let $\beta \in \text{Aut}(\Delta)$ agree with this partial isomorphism. Then $\beta \circ h$ sends a_i to b_i , and so $G \supseteq \text{Aut}(D; T)$.

Case 4. g flips E and N between c and level 0, and preserves E and N between c and level 1. Assume without loss of generality that $g(c) = c$. Then considering g^2 instead of g brings us back to Case 3. \square

Lemma 27. *Let $G \supseteq \text{Aut}(\Delta)$ be a closed group, and assume it generates a canonical function $f: (\Delta, c_1, \dots, c_n) \rightarrow \Delta$, where $c_1, \dots, c_n \in D$. Then one of the following holds:*

- f preserves the order on all levels of $(\Delta, c_1, \dots, c_n)$;
- f reverses the order on all levels of $(\Delta, c_1, \dots, c_n)$;
- G contains either $\text{Aut}(D; <)$, $\text{Aut}(D; E)$, or $\text{Aut}(D; T)$.

Proof. Suppose that the first two cases of the lemma do not apply. Then there are infinite orbits X, Y on different levels such that f reverses the order on one of them, and keeps the order on the other one. Assume without loss of generality that $X < Y$. If f does not preserve the order between X and Y , then let $O \in \{X, Y\}$ be the orbit on which the order is reversed, and assume that the range of f is contained in O by composing it with a self-embedding of Δ if necessary. Then f^2 still reverses the order on precisely one of the orbits X and Y , but preserves the order between X and Y . Replacing f by f^2 we may henceforth assume this situation. Say without loss of generality that f reverses the order on X and preserves the order on Y .

If f eradicates edges or non-edges on X or Y then we are done by Lemma 23, so assume that f either keeps or flips the graph relation on X and on Y . If f flips the graph relation on Y , then assuming $f[D] \subseteq Y$ by virtue of the existence of an appropriate self-embedding of Δ , and replacing f by f^2 , we obtain that f keeps the graph relation on Y , which we will henceforth assume. Referring to Lemma 24 we may also assume that f either keeps or flips the graph relation between X and Y , leaving us with four cases.

Case 1. f keeps the graph relation on X and between X and Y . Then by the above assumptions, f keeps the graph relation on $X \cup Y$. We claim that in this case, G contains $\text{Aut}(D; E)$. To see this, let $a_1, \dots, a_k \in D$ be arbitrary, and assume without loss of generality $a_1 < \dots < a_k$. Let $1 \leq i \leq k$, and let $\alpha \in \text{Aut}(\Delta)$ be so that it sends a_1, \dots, a_{i-1} into X and a_i, \dots, a_k into Y . Then $g := f \circ \alpha$ does not change the graph relation between the a_j , and $g(a_{i-1}) < \dots < g(a_1) < g(a_i) < \dots < g(a_k)$. Now let $\beta \in \text{Aut}(\Delta)$ be so that it sends $g(a_{i-1}), \dots, g(a_1), g(a_i)$ into X and $g(a_{i+1}), \dots, g(a_k)$ into Y . Then $h := f \circ \beta \circ g = f \circ \beta \circ f \circ \alpha$ does not change the graph relation on $\{a_1, \dots, a_k\}$, and $h(a_i) < h(a_1) < \dots < h(a_{i-1}) < h(a_{i+1}) < \dots < h(a_k)$. By repeated application of functions of this form, we can change the order of the a_j ad libitum without changing the graph relation. By the homogeneity of Δ , this implies that any function from $\{a_1, \dots, a_k\}$ to D which keeps the graph relation can be extended to a function in G . Since G is closed we conclude that it contains $\text{Aut}(D; E)$.

Case 2. f keeps the graph relation on X and flips it between X and Y . Let again $a_1, \dots, a_k \in D$, and define h as before. Then as before, h moves a_i below the other a_j ;

however, this time it flips the graph relation between a_i and the other a_j . Let $\gamma \in \text{Aut}(\Delta)$ be so that it moves $h(a_i)$ into X , and the rest of the $h(a_j)$ into Y . Then $f \circ \gamma \circ h$ has the properties of h in Case 1, and we again conclude that G contains $\text{Aut}(D; E)$.

Case 3. f flips the graph relation on X and keeps it between X and Y . Proceeding as in Case 1, we then see that by applications of functions in G we can change the order among any $a_1, \dots, a_k \in D$ arbitrarily; however, this time with every application of f the order relation between distinct a_i, a_j changes if and only if the graph relation changes. This shows that G contains $\text{Aut}(D; T)$.

Case 4. f flips the graph relation on X and flips it between X and Y . Again, we proceed as in Case 1. So let $a_1, \dots, a_k \in D$ and $1 \leq i \leq k$ be as in that case, and define the function h as before. This time, h flips the graph relation between a_i and a_j if and only if $j > i$, for all $1 \leq j \leq k$. Let $\gamma \in \text{Aut}(\Delta)$ be so that it moves $h(a_i)$ into X , and the rest of the $h(a_j)$ into Y . Then $f \circ \gamma \circ h$ differs from h in that it flips the graph relation between a_i and a_j if and only if $j < i$, for all $1 \leq j \leq k$. In other words, it changes the graph relation between two elements in $\{a_1, \dots, a_k\}$ if and only if it changes the order relation between them. As in Case 3 we conclude that G contains $\text{Aut}(D; T)$. \square

Proof of Proposition 12. Assume first that H contains $\text{Aut}(D; <)$, $\text{Aut}(D; E)$, or $\text{Aut}(D; T)$; we claim that then the first case of the statement applies. To see this, note first that if G does not contain any of these groups then we are done, so we may assume the contrary. Now observe that we know all the closed groups containing one of the groups $\text{Aut}(D; <)$, $\text{Aut}(D; E)$, or $\text{Aut}(D; T)$ from the reduct classifications for $(D; <)$, $(D; E)$, and $(D; T)$; by our assumption, G and H are among them. It is therefore enough to check that any two such groups can be distinguished by elements in JI . This is a mere checking of containment relations in Figure 3 using the relational descriptions of the groups above $\text{Aut}(D; <)$, $\text{Aut}(D; E)$, and $\text{Aut}(D; T)$ and left to the reader.

Now let $c_1, \dots, c_n \in D$ with $c_1 < \dots < c_n$ and $f: (\Delta, c_1, \dots, c_n) \rightarrow \Delta$ be a canonical function which is generated by H but not by G . By Lemma 27 we may assume that f either preserves the order on all levels, or it reverses the order on all levels; for otherwise, H contains $\text{Aut}(D; <)$, $\text{Aut}(D; E)$, or $\text{Aut}(D; T)$ and we are done. In the latter case, H contains either $\binom{\text{id}}{\leftrightarrow}$ or $\binom{-}{\leftrightarrow}$; denote this function by g . If $g \notin G$ then we are done, so we may assume $g \in G$. Then $g \circ f$ is still not generated by G , and preserves the order on all levels; replacing f by $g \circ f$ we may thus assume that f preserves the order on all levels. In particular, orbits on the same level stay on the same level when applying f .

Suppose there are $0 \leq i < j \leq n$ such that f sends level i above level j with respect to the order. Then let (i, j) be the smallest such pair with respect to the lexicographic order. By Lemma 25, H contains $\text{Aut}(D; <)$, $\binom{\text{id}}{\circ}$, or $\binom{\text{sw}}{\circ}$. In the first case we are done, so assume the second or third case and denote the corresponding function by g' . As above, if $g' \notin G$ then we are done, so we may assume $g' \in G$. We may assume that the irrational number π around which g' turns lies between the images of the i -th and j -th level under f , and that levels are either sent entirely above or below π under f . Then $g' \circ f$ is still canonical, is still not generated by G because $g' \in G$, and if there are still $0 \leq i' < j' \leq m$ as above for this new function, then (i', j') is larger than (i, j) in the lexicographic order. Hence repeating this process we may assume that f preserves the order between all levels. Now suppose that there is $1 \leq i \leq n$ such that c_i is either sent by f below level $i - 1$ or above level i . Assuming without loss of generality the latter, consider the structure induced by the union of level $i - 1$,

level i , and $\{c_i\}$. By Lemma 26 we are done. Thus, the only remaining possibility is that f is order preserving, and so the second statement of the proposition holds. \square

5. THE ORDERED CASE

Definition 28. We will denote the set of those groups in JI which preserve the order relation $<$ by JI° . We moreover denote the set containing all joins of groups in JI° as well as $\text{Aut}(\Delta)$ (i.e., the set of groups below the label j corresponding to the group $\text{Aut}(D; <)$ in Figure 3) by OP .

The main goal of this section is to prove

Proposition 29. *Let $G, H \supseteq \text{Aut}(\Delta)$ be closed groups such that there exist $c_1, \dots, c_n \in D$ and an order preserving canonical function $f: (\Delta, c_1, \dots, c_n) \rightarrow \Delta$ which is generated by H but not by G . Then there exists an element of JI° which is contained in H but not in G .*

Together with Proposition 12 from the preceding section, this will complete the proof of Proposition 3; confer also the overview in Section 3. The proof of Proposition 29 will be given just before Section 5.5, assuming the truth of a certain statement (Lemma 55). That statement will then be shown in Section 5.5.

5.1. Homogeneity of the order preserving reducts. In this subsection we will prove the following.

Proposition 30. *All groups in OP are automorphism groups of homogeneous structures in a 4-ary language.*

The homogeneity in a 4-ary language will later be used in Proposition 58 when we compare behaviors of canonical functions with groups in OP .

JI° contains precisely five groups: the small groups $\langle(-)\rangle$, $\langle(\text{sw}_{\text{id}})\rangle$, the medium-sized groups $\langle(\text{id}^l)\rangle$, $\langle(\text{id}^u)\rangle$, and the large group $\text{Aut}(D; <)$. For the two small groups and their join, the statement follows from a general fact about reducts of superposed homogeneous structures (Section 5.1.1). The statement is most interesting for the group $\langle(\text{id}^l)\rangle$ (Proposition 36), the group $\langle(\text{id}^u)\rangle$ (Proposition 41), and the group $\langle(\text{id}^l), (\text{id}^u)\rangle$ (Proposition 42). We finally show in Section 5.1.4 that OP consists of precisely eight groups, and prove that also the remaining groups are homogeneous in a language of maximal arity four.

5.1.1. Homogeneous reducts of superposed structures. Note that $\langle(\text{sw}_{\text{id}})\rangle = \text{Aut}(D; <, R^{(3)})$: this follows from the description of $\text{Aut}(D; R^{(3)})$ in terms of sw from Section 2.1.2 and the fact that E and $<$, and hence also R^3 and $<$, are freely superposed. To show homogeneity of $(D; <, R^{(3)})$, we will use the following.

Lemma 31. *Let Δ be the free superposition of two homogeneous structures Γ_1 and Γ_2 . We may assume that both Γ_1 and Γ_2 are reducts of Δ . Also suppose that Γ_1 has a homogeneous reduct Γ'_1 and Γ_2 has a homogeneous reduct Γ'_2 . Let Δ' be the reduct of Δ that contains precisely the relations of Γ'_1 and Γ'_2 . Then Δ' is the free superposition of Γ'_1 and Γ'_2 , and in particular homogeneous.*

Proof. This follows from the definition of superpositions, and a straightforward back-and-forth argument. \square

It is well-known that $(D; R^{(3)})$ is homogeneous; see e.g. [Mac11]. Hence, Lemma 31 implies the homogeneity of $(D; <, R^{(3)})$. We would like to use Lemma 31 to also prove Proposition 30 for the group $\langle\langle \bar{\text{id}} \rangle\rangle$ and the group $\langle\langle \bar{\text{id}}^{\text{sw}}, \bar{\text{id}} \rangle\rangle$. Note that $\langle\langle \bar{\text{id}} \rangle\rangle = \text{Aut}(D; R^{(4)}, <)$ and that $\langle\langle \bar{\text{id}}^{\text{sw}}, \bar{\text{id}} \rangle\rangle = \text{Aut}(D; R^{(5)}, <)$, by the results from Section 2.1.2. Let P be the relation

$$\{(x, y, z) \in D^3 \mid (E(x, y) \wedge N(x, z) \wedge N(y, z)) \vee (N(x, y) \wedge E(x, z) \wedge E(y, z))\}.$$

Proposition 32. *We have $\text{Aut}(D; R^{(4)}) = \text{Aut}(D; P)$, and $(D; P)$ is homogeneous.*

Proof. It is clear that P is not preserved by sw , but preserved by $-$, and hence, by the result of Thomas described in Section 2.1.2, it follows that $\text{Aut}(D; P) = \text{Aut}(D; R^{(4)})$. To prove homogeneity of $(D; P)$, let $(a_1, \dots, a_n), (b_1, \dots, b_n) \in D^n$, and let α be a partial isomorphism of $(D; P)$ with domain $A := \{a_1, \dots, a_n\}$ such that $\alpha(a_i) = b_i$ for all $i \leq n$. We have to show that α can be extended to an automorphism of $(D; P)$. For $n = 1$ this is trivial. For $n \geq 2$, we first treat the case that $E(a_1, a_2)$ and $E(b_1, b_2)$. If for some $i \leq n$ the element a_i is neither adjacent to a_1 nor to a_2 , then b_i is adjacent to neither b_1 nor b_2 , since α preserves the relation P . If a_i is adjacent to a_1 , but not to a_2 , then b_i must be adjacent to b_1 , but not to b_2 , again because of preservation of P . Similarly, when a_i is adjacent to a_2 but not to a_1 then b_i must be adjacent to b_2 but not to b_1 . The only remaining situation is that a_i is adjacent to both a_1 and a_2 . In this case also b_i is adjacent to both b_1 and b_2 , by the assumption that also $\neg P$ is preserved and reasoning as above. Now suppose that $i, j \leq n$. Since $E(a_1, a_i)$ iff $E(b_1, b_i)$ and $E(a_2, a_i)$ iff $E(b_2, b_i)$, and by preservation of P and $\neg P$ we have that $E(a_i, a_j)$ iff $E(b_i, b_j)$. Hence, α must be a partial isomorphism of $(D; E)$ and by homogeneity of $(D; E)$ it can be extended to an automorphism of $(D; E)$, and therefore also to an automorphism of $(D; P)$.

Next, consider the situation that $E(a_1, a_2)$ and $N(b_1, b_2)$. In this case, the map $x \mapsto -\alpha(x)$ defined on A is a partial isomorphism of $(D; P)$ that satisfies the assumption above, and hence it can be extended to an automorphism β of $(D; P)$. Then $-\beta^{-1} \circ \alpha$ is an automorphism of $(D; P)$ that extends α . Similarly, when $N(a_1, a_2)$ we consider $x \mapsto \alpha(-x)$ and thereby reduce the argument to the situation above. \square

As explained above, the following is a consequence of Proposition 32 and Lemma 31.

Corollary 33. *We have $\langle\langle \bar{\text{id}} \rangle\rangle = \text{Aut}(D; P, <)$, and $(D; P, <)$ is homogeneous.*

Let $(a, b, c, d) \in D^4$ be such that (a, d) is the only edge induced by a, b, c, d . Let Q be the smallest relation that contains (a, b, c, d) and is preserved by $\text{Aut}(D; E) \cup \{\text{sw}, -\}$.

Proposition 34. *$\text{Aut}(D; R^{(5)}) = \text{Aut}(D; Q)$, and $(D; Q)$ is homogeneous.*

Proof. The proof follows the same strategy as the proof of Proposition 32. Again it follows from the results mentioned in Section 2.1.2 that $\text{Aut}(D; R^{(5)}) = \text{Aut}(D; Q)$. To prove the homogeneity of $(D; Q)$, let $(a_1, \dots, a_n), (b_1, \dots, b_n) \in D^n$, and let α be a partial isomorphism of $(D; Q)$ with domain $\{a_1, \dots, a_n\}$ which maps a_i to b_i for all $i \leq n$. We have to show that α can be extended to an automorphism of $(D; Q)$. This is easy to see for $n \leq 3$. For $n > 3$, we first treat the case that a_1, a_2, a_3 and b_1, b_2, b_3 are independent sets in $(D; E)$, and that for each $i \leq n$ the element a_i is adjacent to at most one of a_1, a_2, a_3 and b_i is adjacent to at most one of b_1, b_2, b_3 . If for some $i \leq n$ the element a_i is adjacent to none of a_1, a_2, a_3 , then $\neg Q(a_1, a_2, a_3, a_i)$, and therefore also $\neg Q(b_1, b_2, b_3, b_i)$, which implies that b_i is adjacent to none of b_1, b_2, b_3 . Moreover, preservation of Q and $\neg Q$ implies that for all $i \leq n$ and $j \in \{1, 2, 3\}$ the element a_i is adjacent to a_j if and only if b_i is adjacent to b_j . This fact and again preservation of Q and $\neg Q$ imply that for all $i, j \leq n$, a_i is adjacent to a_j if and only if b_i is adjacent to b_j .

Hence, α must be a partial isomorphism of $(D; E)$, and by homogeneity of $(D; E)$ it can be extended to an automorphism of $(D; E)$, and therefore also to an automorphism of $(D; Q)$.

In the general case, when a_1, a_2, a_3 and b_1, b_2, b_3 are not necessarily independent sets, it is easy to see that we can choose $\beta_1, \beta_2 \in \text{Aut}(D; Q)$ such that $\gamma := \beta_1 \circ \alpha \circ \beta_2^{-1}$ is a partial isomorphism on $(D; Q)$ where

- $\{\beta_2(a_1), \beta_2(a_2), \beta_2(a_3)\}$ forms an independent set;
- $\{\beta_1(b_1), \beta_1(b_2), \beta_1(b_3)\}$ forms an independent set;
- for $i \leq n$, $\beta_2(a_i)$ is adjacent to at most one of $\beta_2(a_1), \beta_2(a_2), \beta_2(a_3)$;
- for $i \leq n$, $\beta_1(b_i)$ is adjacent to at most one of $\beta_1(b_1), \beta_1(b_2), \beta_1(b_3)$.

The previous paragraph implies that γ can be extended to $\gamma' \in \text{Aut}(D; E)$. Then $\beta_1^{-1}\gamma'\beta_2$ is an automorphism of $(D; Q)$ which extends α . This shows homogeneity of $(D; Q)$. \square

The following is a consequence of Proposition 34 in combination with Lemma 31.

Corollary 35. *We have $\langle\langle \bar{\text{id}}, \text{id}^{\text{sw}} \rangle\rangle = \text{Aut}(D; Q, <)$, and $(D; Q, <)$ is homogeneous.*

5.1.2. *Homogeneous structures for the medium-sized groups.* We now turn to the medium-sized group $\langle\langle \binom{l}{\text{id}} \rangle\rangle$. Recall that $\binom{l}{\text{id}}$ is a permutation which preserves $<$ and switches the graph relation below some irrational π . We now come to a statement that has already been announced in Section 2.3.

Proposition 36. *We have $\langle\langle \binom{l}{\text{id}} \rangle\rangle = \text{Aut}(D; R_3^l)$. The structure $(D; R_3^l)$ is homogeneous.*

To prove this proposition, we need some definitions and preparatory lemmas.

Definition 37. Let $S = \{v_1, \dots, v_n\} \subseteq D$ with $v_1 < \dots < v_n$. We say that an order preserving map $\delta: S \rightarrow D$ is *lower layered* iff there exists a Boolean vector $t = (t_1, \dots, t_{n-1}) \in \{0, 1\}^{n-1}$ such that for $i, j \in \{1, \dots, n\}$, $i < j$, we have that $E(\delta(v_i), \delta(v_j))$ if and only if one of the following holds:

- (1) $E(v_i, v_j)$ and $\sum_{j-1 \leq k < n} t_k$ is even
- (2) $N(v_i, v_j)$ and $\sum_{j-1 \leq k < n} t_k$ is odd.

A permutation δ of D is called *lower layered* iff all its finite-range restrictions are lower layered.

An example of a permutation that is lower layered is $\binom{l}{\text{id}}$. It will be convenient to be slightly sloppy with notation by identifying 0 with N and 1 with E , so that the condition from Definition 37 can be rewritten to

$$E(\delta(v_i), \delta(v_j)) = E(v_i, v_j) + \sum_{j-1 \leq k < n} t_k ;$$

all arithmetic in this section is modulo 2.

Lemma 38. *Let $S \subseteq D$ be finite, and $\gamma: S \rightarrow D$ be a partial isomorphism of $(D; R_3^l)$. Then γ is lower layered.*

Proof. Our proof is by induction on the cardinality n of S . The statement is clearly true for $n = 1$ and $n = 2$. Now suppose that the statement is true for $n \geq 2$. We want to show it for $n + 1$. Write $S = \{v_1, \dots, v_n, v_{n+1}\}$ with $v_1 < \dots < v_n < v_{n+1}$. By induction hypothesis, there exists $t \in \{0, 1\}^{n-1}$ such that for all $i, j \in \{2, \dots, n+1\}$ with $i < j$

$$E(\gamma(v_i), \gamma(v_j)) = E(v_i, v_j) + \sum_{j-2 \leq k < n} t_k .$$

Define $t' \in \{0, 1\}^n$ by $t'_i := t_{i-1}$ for $i \in \{2, \dots, n\}$, and

$$t'_1 := E(\gamma(v_1), \gamma(v_2)) + E(v_1, v_2) + \sum_{1 \leq k < n} t_k.$$

We claim that for $i, j \in \{1, \dots, n+1\}$, $i < j$, we have

$$(1) \quad E(\gamma(v_i), \gamma(v_j)) = E(v_i, v_j) + \sum_{j-1 \leq k < n+1} t'_k.$$

This is true for $i, j \in \{2, \dots, n+1\}$ by induction assumption. Otherwise, $i = 1$. First consider the case that $j = 2$. By definition of t'_1 we have

$$E(\gamma(v_1), \gamma(v_2)) = E(v_1, v_2) + t'_1 + \sum_{1 \leq k < n} t_k,$$

which equals $E(v_1, v_2) + \sum_{1 \leq k < n+1} t'_k$ by definition of t'_k for $k > 1$. Hence, Equation (1) is true in this case.

Now consider the case that $j > 2$. Since γ preserves R_3^l and $\neg R_3^l$ we have that

$$E(v_1, v_j) + E(v_2, v_j) = E(\gamma(v_1), \gamma(v_j)) + E(\gamma(v_2), \gamma(v_j)).$$

Therefore, and by induction hypothesis we have

$$\begin{aligned} E(\gamma(v_1), \gamma(v_j)) &= E(v_1, v_j) + E(v_2, v_j) + E(\gamma(v_2), \gamma(v_j)) \\ &= E(v_1, v_j) + E(v_2, v_j) + E(v_2, v_j) + \sum_{j-2 \leq k < n} t_k \\ &= E(v_1, v_j) + \sum_{j-1 \leq k < n+1} t'_k, \end{aligned}$$

which is what we had to show. \square

Lemma 39. *Let $S \subseteq D$ be finite, and let $\gamma: S \rightarrow D$ be lower layered. Then γ can be extended to an element of $\langle\langle \binom{l}{\text{id}} \rangle\rangle$.*

Proof. Write $S = \{v_1, \dots, v_n\}$ with $v_1 < \dots < v_n$, and let $t \in \{0, 1\}^{n-1}$ be the witness that γ is a lower layered permutation on S . We will show that there exists a sequence $\beta_1, \dots, \beta_n \in \text{Aut}(D; E, <)$ and a sequence $\alpha_1, \dots, \alpha_{n-1} \in \{\binom{l}{\text{id}}, \text{id}\}$ such that $\gamma(x) = \beta_n \alpha_{n-1} \beta_{n-1} \dots \alpha_1 \beta_1(x)$ for all $x \in S$.

Choose a $\beta_1 \in \text{Aut}(D; E, <)$ that maps (v_1, v_2) below π and (v_3, \dots, v_n) above π . Choose α_1 to be $\binom{l}{\text{id}}$ if $t_1 = 0$, and the identity otherwise. To define β_i for $2 \leq i \leq n-1$, suppose that β_j has been defined for $j < i$, and write γ' for $\binom{l}{\text{id}} \beta_{i-1} \binom{l}{\text{id}} \dots \binom{l}{\text{id}} \beta_1$. Then choose a $\beta_i \in \text{Aut}(D; E, <)$ that maps $\gamma'(v_1, \dots, v_{i+1})$ below π and $\gamma'(v_{i+2}, \dots, v_n)$ above π . Choose α_i to be $\binom{l}{\text{id}}$ if $t_i = 0$, and the identity otherwise. Then it is easy to verify that the restriction of $\alpha_{n-1} \beta_{n-1} \dots \alpha_1 \beta_1$ to S is a partial isomorphism of $(D; E, <)$; by homogeneity of $(D; E, <)$ there exists a $\beta_n \in \text{Aut}(D; E, <)$ such that $\gamma(x) = \beta_n \alpha_{n-1} \beta_{n-1} \dots \alpha_1 \beta_1(x)$ for all $x \in S$. \square

We finally give our operational reduct characterization.

Proposition 40. *Let γ be a permutation of D . Then the following are equivalent.*

- (1) γ is generated by $\binom{l}{\text{id}}$.
- (2) $\gamma \in \text{Aut}(D; R_3^l)$.
- (3) γ is lower layered.

Proof. For the implication from (1) to (2) it suffices to verify that $\langle \binom{l}{\text{id}} \rangle$ preserves R_3^l , which is straightforward. To show that (2) implies (3), let $\gamma \in \text{Aut}(D; R_3^l)$ be arbitrary. Lemma 38 shows that the restriction of γ to finite subsets S of D is layered, and hence γ is lower layered. The implication from (3) to (1) follows from Lemma 39 and local closure. \square

Proof of Proposition 36. The equality $\text{Aut}(D; R_3^l) = \langle \binom{l}{\text{id}} \rangle$ follows immediately from the equivalence of (1) and (2) in Proposition 40. To show homogeneity of $(D; R_3^l)$, let γ be a partial isomorphism of $(D; R_3^l)$. By Lemma 38, γ is lower layered. By Lemma 39, γ is the restriction of an automorphism of $(D; R_3^l)$, which is what we had to show. \square

Proposition 36 has the following dual version, which has also been announced in Section 2.3, and which can be shown analogously.

Proposition 41. *We have $\langle \binom{u}{\text{id}} \rangle = \text{Aut}(D; R_3^u)$. The structure $(D; R_3^u)$ is homogeneous.*

5.1.3. *A homogeneous structure for $\langle \binom{l}{\text{id}}, \binom{u}{\text{id}} \rangle$.* We now present a description of the join of the previous two medium-sized groups. First set

$$S_4 := \{(a_1, \dots, a_4) \mid a_1 < a_2 < a_3 < a_4 \text{ and } E(a_1, a_3) + E(a_1, a_4) + E(a_2, a_3) + E(a_2, a_4) = 0\}.$$

Proposition 42. *We have $\langle \binom{l}{\text{id}}, \binom{u}{\text{id}} \rangle = \text{Aut}(D; S_4)$. The structure $(D; S_4)$ is homogeneous.*

Definition 43. Let $S = \{v_1, \dots, v_n\} \subseteq D$ be of cardinality n . A function $\delta: S \rightarrow D$ is called *layered* if there exist vectors $s, t \in \{0, 1\}^{n-1}$ such that for $i, j \in \{1, \dots, n\}$, $i < j$, we have

$$E(\delta(v_i), \delta(v_j)) = E(v_i, v_j) + \sum_{1 \leq k \leq i} s_k + \sum_{j-1 \leq k < n} t_k.$$

Lemma 44. *Let $S \subseteq D$ be finite, and $\gamma: S \rightarrow D$ be an isomorphism between the substructures of $(D; S_4)$ induced by S and by $\gamma(S)$. Then γ is layered.*

Proof. As in the proof of Proposition 40, our proof is by induction on the cardinality n of S . The statement is clearly true for $n \in \{1, 2, 3\}$. Now suppose that we have shown the claim for $n \geq 3$, and that we want to show it for $n+1$. Write $S = \{v_1, \dots, v_{n+1}\}$ with $v_1 < \dots < v_{n+1}$. By induction hypothesis, there exist $s, t \in \{0, 1\}^{n-1}$ such that for all $i, j \in \{1, \dots, n\}$ we have

$$E(\gamma(v_i), \gamma(v_j)) = E(v_i, v_j) + \sum_{1 \leq k \leq i} s_k + \sum_{j-1 \leq k < n} t_k.$$

We can assume without loss of generality that $s_1 = 0$ (otherwise, replace t_{n-1} by $1 + t_{n-1}$ and s_1 by $1 + s_1$). Define $t' \in \{0, 1\}^n$ by

- $t'_n := E(v_1, v_{n+1}) + E(\gamma(v_1), \gamma(v_{n+1}))$,
- $t'_{n-1} := t_{n-1} + t'_n$, and
- $t'_i = t_i$ for $i \in \{1, \dots, n-2\}$.

Furthermore, define $s' \in \{0, 1\}^n$ by $s'_i := s_i$ for $i \in \{1, \dots, n-1\}$, and

$$s'_n := E(\gamma(v_n), \gamma(v_{n+1})) + E(v_n, v_{n+1}) + \sum_{1 \leq k < n} s_k + t'_n.$$

We claim that for $i, j \in \{1, \dots, n+1\}$, $i < j$, we have

$$E(\gamma(v_i), \gamma(v_j)) = E(v_i, v_j) + \sum_{1 \leq k \leq i} s'_k + \sum_{j-1 \leq k < n+1} t'_k.$$

This is true for $i, j \in \{1, \dots, n\}$ since

$$\begin{aligned} E(\gamma(v_i), \gamma(v_j)) &= E(v_i, v_j) + \sum_{1 \leq k \leq i} s_k + \sum_{j-1 \leq k < n} t_k \\ &= E(v_i, v_j) + \sum_{1 \leq k \leq i} s'_k + t'_n + \sum_{j-1 \leq k < n} t'_k \\ &= E(v_i, v_j) + \sum_{1 \leq k \leq i} s'_k + \sum_{j-1 \leq k < n+1} t'_k \end{aligned}$$

by induction assumption and the definition of s' and t' .

Otherwise, $j = n + 1$. Consider first the case that $i = 1$. Then by definition of t'_n we have

$$\begin{aligned} (2) \quad E(\gamma(v_1), \gamma(v_{n+1})) &= E(v_1, v_{n+1}) + t'_n \\ &= E(v_1, v_{n+1}) + \sum_{1 \leq k \leq 1} s'_k + \sum_{n \leq k < n+1} t'_k \end{aligned}$$

which is what we had to show.

Next, consider the case that $i \in \{2, \dots, n-1\}$. Since γ preserves S_4 and preserves $\neg S_4$ we have that

$$(3) \quad \begin{aligned} &E(v_i, v_n) + E(v_i, v_{n+1}) + E(v_1, v_n) + E(v_1, v_{n+1}) \\ &= E(\gamma(v_i), \gamma(v_n)) + E(\gamma(v_i), \gamma(v_{n+1})) + E(\gamma(v_1), \gamma(v_n)) + E(\gamma(v_1), \gamma(v_{n+1})) . \end{aligned}$$

Since

$$\begin{aligned} E(\gamma(v_i), \gamma(v_n)) &= E(v_i, v_n) + \sum_{1 \leq k \leq i} s'_k + \sum_{n-1 \leq k < n+1} t'_k \\ &= E(v_i, v_n) + \sum_{1 \leq k \leq i} s'_k + (t'_{n-1} + t'_n) + t'_n \\ &= E(v_i, v_n) + \sum_{1 \leq k \leq i} s'_k + t_{n-1} \end{aligned}$$

and

$$\begin{aligned} E(\gamma(v_1), \gamma(v_n)) &= E(v_1, v_n) + \sum_{1 \leq k \leq 1} s'_k + \sum_{n-1 \leq k < n+1} t'_k \\ &= E(v_1, v_n) + t_{n-1} \end{aligned}$$

Equation 3 simplifies to

$$\begin{aligned} &E(v_i, v_{n+1}) + E(v_1, v_{n+1}) \\ &= E(\gamma(v_i), \gamma(v_{n+1})) + E(\gamma(v_1), \gamma(v_{n+1})) + \sum_{1 \leq k \leq i} s'_k . \end{aligned}$$

Therefore,

$$\begin{aligned}
E(\gamma(v_i), \gamma(v_{n+1})) &= E(v_i, v_{n+1}) + E(v_1, v_{n+1}) + \sum_{1 \leq k \leq i} s'_k + E(\gamma(v_1), \gamma(v_{n+1})) \\
&= E(v_i, v_{n+1}) + E(v_1, v_{n+1}) + \sum_{1 \leq k \leq i} s'_k + E(v_1, v_{n+1}) + t'_n \\
&= E(v_i, v_{n+1}) + \sum_{1 \leq k \leq i} s'_k + \sum_{n \leq k < n+1} t'_k
\end{aligned}$$

Finally, consider the case $i = n$. By definition of s'_n we have

$$\begin{aligned}
E(\gamma(v_n), \gamma(v_{n+1})) &= E(v_n, v_{n+1}) + \sum_{1 \leq k < n} s_k + s'_n + t'_n \\
&= E(v_n, v_{n+1}) + \sum_{1 \leq k < n+1} s'_k + \sum_{n \leq k < n+1} t'_k
\end{aligned}$$

and this concludes the induction. \square

Lemma 45. *Let $S \subseteq D$ be finite, and let $\gamma: S \rightarrow D$ be layered. Then γ can be extended to an element of $\langle \binom{l}{\text{id}}, \binom{u}{\text{id}} \rangle$.*

Proof. This can be shown analogously to Lemma 39. \square

Proposition 46. *Let γ be a permutation of D . Then the following are equivalent.*

- (1) γ is generated by $\{ \binom{l}{\text{id}}, \binom{u}{\text{id}} \}$.
- (2) $\gamma \in \text{Aut}(D; S_4)$.
- (3) γ is a layered permutation.

Proof. For the implication (1) \Rightarrow (2) it suffices to show that both $\binom{l}{\text{id}}$ and $\binom{u}{\text{id}}$ preserve S_4 , which is straightforward. To prove (2) \Rightarrow (3), let $\gamma \in \text{Aut}(D; S_4)$ be arbitrary. Lemma 44 shows that the restriction of γ to finite subsets of D is layered, and hence γ is layered. The implication (3) \Rightarrow (1) follows from Lemma 45 and local closure. \square

Proof of Proposition 42. The equality $\text{Aut}(D; S_4) = \langle \binom{l}{\text{id}} \rangle$ follows immediately from the equivalence of (1) and (2) in Proposition 46. To show homogeneity of $(D; S_4)$, let γ be a partial isomorphism of $(D; S_4)$. By Lemma 44, γ is layered. By Lemma 45, the function γ is the restriction of an automorphism of $(D; S_4)$, which is what we had to show. \square

5.1.4. All groups in OP.

Proof of Proposition 30. It is clear that $\langle \binom{-}{\text{id}} \rangle$ is contained in $\langle \binom{l}{\text{id}} \rangle$, and analogously that it is contained in $\langle \binom{u}{\text{id}} \rangle$. Moreover, it is clear that $\langle \binom{\text{sw}}{\text{id}}, \binom{l}{\text{id}} \rangle$ contains $\langle \binom{u}{\text{id}} \rangle$, since $\binom{-}{\text{id}} \circ \binom{\text{sw}}{\text{id}} \circ \binom{l}{\text{id}}$ (here, we assume that the irrational number π used to define $\binom{l}{\text{id}}$ equals the irrational number used to define $\binom{\text{sw}}{\text{id}}$) behaves as $\binom{u}{\text{id}}$. Dually, $\langle \binom{\text{sw}}{\text{id}}, \binom{u}{\text{id}} \rangle$ contains $\langle \binom{l}{\text{id}} \rangle$. Finally, $\langle \binom{l}{\text{id}}, \binom{u}{\text{id}} \rangle$ contains $\binom{\text{sw}}{\text{id}}$ since $\binom{-}{\text{id}} \circ \binom{l}{\text{id}} \circ \binom{u}{\text{id}}$ behaves as $\binom{\text{sw}}{\text{id}}$. All these groups are contained in $\text{Aut}(D; <)$, and contain $\text{Aut}(\Delta)$. This shows that OP consists of precisely the groups $\text{Aut}(\Delta)$, $\langle \binom{\text{sw}}{\text{id}} \rangle$, $\langle \binom{-}{\text{id}} \rangle$, $\langle \binom{\text{sw}}{\text{id}}, \binom{-}{\text{id}} \rangle$, $\langle \binom{l}{\text{id}} \rangle$, $\langle \binom{u}{\text{id}} \rangle$, $\langle \binom{l}{\text{id}}, \binom{u}{\text{id}} \rangle$, and $\text{Aut}(D; <)$. We verify for each of those groups G that there exists a homogeneous structure Γ with an at most 4-ary language such that $\text{Aut}(\Gamma) = G$.

- Since $(D; <)$ and $(D; E, <)$ are homogeneous, we are done for those groups.

- For the groups $\langle(\bar{\cdot})_{\text{id}}^l\rangle$, $\langle(\bar{\cdot})_{\text{id}}^u\rangle$, $\langle(\bar{\cdot})_{\text{id}}^l, (\bar{\cdot})_{\text{id}}^u\rangle$, the statement has been shown in Proposition 36, Proposition 41, and Proposition 42.
- The groups $\langle(\bar{\cdot})_{\text{id}}\rangle$, $\langle(\bar{\cdot})_{\text{id}}^{\text{sw}}\rangle$, and $\langle(\bar{\cdot})_{\text{id}}^{\text{sw}}, (\bar{\cdot})_{\text{id}}\rangle$ have been treated in Section 5.1.1.

This concludes the proof that all groups in OP are automorphisms groups of homogeneous structures in an at most 4-ary language. \square

Note that when a structure is homogeneous in an at most 4-ary language, then it is also homogeneous in a 4-ary language (using dummy variables). From now on, we will therefore use the shorter phrase ‘homogeneous in a 4-ary language’ instead of ‘homogeneous in an at most 4-ary language’.

5.2. Moving above $\text{Aut}(D; <)$ by order preserving behaviors.

Lemma 47. *Let $G \supseteq \text{Aut}(\Delta)$ be a closed group generating an order preserving canonical function $f: (\Delta, c_1, \dots, c_n) \rightarrow \Delta$, where $c_1, \dots, c_n \in D$. Suppose that there exist infinite orbits X, Y of $(\Delta, c_1, \dots, c_n)$ satisfying $\neg(Y < X)$ such that f sends all pairs (x, y) , where $x \in X$, $y \in Y$, and $x < y$, to edges, or, dually, to non-edges. Then $G \supseteq \text{Aut}(D; <)$.*

Proof. If f eradicates edges or non-edges on Y then we are done by Lemma 23, so we may assume that it keeps or flips the graph relation on Y . If f flips the graph relation on Y , then pick any self-embedding e of Δ whose range is contained in Y ; replacing f by $f \circ e \circ f$ we then have a function which still satisfies the assumptions of the lemma, and which keeps the graph relation on Y .

Let a_1, \dots, a_k be elements of D with $a_1 < \dots < a_k$, let $1 \leq i \leq k$, and let $\alpha \in \text{Aut}(\Delta)$ be such that $\alpha[\{a_1, \dots, a_i\}] \subseteq X$ and $\alpha[\{a_{i+1}, \dots, a_k\}] \subseteq Y$. Then $f \circ \alpha$ is order preserving, keeps the graph relation on $\{a_{i+1}, \dots, a_k\}$, and eradicates non-edges between $\{a_1, \dots, a_i\}$ and $\{a_{i+1}, \dots, a_k\}$. By applying this step iteratively starting with $i = k$ and finishing with $i = 1$, we have that the set $\{a_1, \dots, a_k\}$ is mapped to a complete graph by a function generated by f . Thus, G contains $\text{Aut}(D; <)$ by Lemma 22. \square

Lemma 48. *Let $G \supseteq \text{Aut}(\Delta)$ be a closed group generating an order preserving canonical function $f: (\Delta, c_1, \dots, c_n) \rightarrow \Delta$, where $c_1, \dots, c_n \in D$. Assume that f keeps the graph relation on $D \setminus \{c_1, \dots, c_n\}$. Assume moreover that there exist infinite orbits X, Y of $(\Delta, c_1, \dots, c_n)$ on the same level and $1 \leq i \leq n$ such that f keeps the graph relation between $\{c_i\}$ and X , and flips the graph relation between $\{c_i\}$ and Y . Then $G \supseteq \text{Aut}(D; <)$.*

Proof. Without loss of generality assume that $\{c_i\} < X$ (and hence $\{c_i\} < Y$). Assume first that there are edges between c_i and all elements of $X \cup Y$. Then let Z be an infinite orbit at the level of X and Y whose elements are not adjacent to c_i . Because f is canonical, it keeps or flips the graph relation between $\{c_i\}$ and Z . Replacing X by Z in the first case and Y by Z in the latter case, we then have that c_i is adjacent to the elements of precisely one of the sets X and Y . Arguing dually in the case where c_i is adjacent to none of the elements in $X \cup Y$, we obtain the same situation. Without loss of generality, we henceforth assume that c_i is adjacent to the elements of X , and not adjacent to those of Y .

Let a_1, \dots, a_k be elements of D such that $a_1 < \dots < a_k$, and let $1 \leq j \leq k$. There is a permutation $\delta \in \text{Aut}(\Delta)$ that maps a_j to c_i and $\{a_{j+1}, \dots, a_k\}$ into $X \cup Y$ (by our assumption above, those elements adjacent to a_j must go into X , and the others into Y). Then $f \circ \delta$ does not modify the graph relation on $\{a_{j+1}, \dots, a_k\}$, and eradicates non-edges between $\{a_j\}$ and $\{a_{j+1}, \dots, a_k\}$. Hence, applying such functions from $j = k$ until $j = 1$, $\{a_1, \dots, a_k\}$ can be mapped to an independent set, and the lemma follows from Lemma 22. \square

Lemma 49. *Let $G \supseteq \text{Aut}(\Delta)$ be a closed group generating an order preserving canonical function $f: (\Delta, c_1, \dots, c_n) \rightarrow \Delta$, where $c_1, \dots, c_n \in D$. Assume that f keeps the graph relation on $D \setminus \{c_1, \dots, c_n\}$. Assume moreover that there exist distinct levels L_1, L_2, L_3 of $(\Delta, c_1, \dots, c_n)$ and $1 \leq i \leq n$ with $L_1 < \{c_i\} < L_2, L_3$ such that f keeps the graph relation between $\{c_i\}$ and $L_1 \cup L_3$, and such that f flips the graph relation between $\{c_i\}$ and L_2 . Then $G \supseteq \text{Aut}(D; <)$.*

Proof. Let $\gamma \in \text{Aut}(\Delta)$ be such that $\gamma(c_i) = c_i$, everything above c_i is mapped into L_2 , and everything below c_i is mapped into L_1 . Then $f \circ \gamma \circ f$ is a canonical function $(\Delta, c_1, \dots, c_n) \rightarrow \Delta$ generated by G , keeps the graph relation between c_i and L_1 , and switches the role of L_2 and L_3 . Hence, we may assume that $L_2 < L_3$. Let A be an arbitrary finite subset of D that consists of the elements $a_1 < \dots < a_k$. Let $1 \leq j < m \leq k$. There is a permutation $\delta \in \text{Aut}(\Delta)$ that maps a_j to c_i , $\{a_1, \dots, a_{j-1}\}$ into L_1 , $\{a_{j+1}, \dots, a_{m-1}\}$ into L_2 , and $\{a_m, \dots, a_k\}$ into L_3 . Then $f \circ \delta$ flips the graph relation between a pair of elements in A if and only if one of them is a_j and the index r of the other is such that $j < r < m$. Applying the same modification with the pair $(j, m+1)$ instead of (j, m) , these two modifications combined flip the graph relation between a_j and a_m , and nowhere else in A . Hence, A can be mapped to an independent set in a finite number of such steps, and the lemma follows from Lemma 22. \square

5.3. Moving above $\binom{u}{\text{id}}$ and $\binom{\text{sw}}{\text{id}}$.

Lemma 50. *Let $G \supseteq \text{Aut}(\Delta)$ be a closed group, and let $f: (\Delta, c_1, \dots, c_n) \rightarrow \Delta$ be an order preserving canonical function generated by G , where $c_1, \dots, c_n \in D$. Assume that there exists $1 \leq i \leq n$ and levels X, Y of $(\Delta, c_1, \dots, c_n)$ with $X < \{c_i\} < Y$ such that f keeps the graph relation on $X \cup Y$ as well as between X and $\{c_i\}$, and such that f flips the graph relation between $\{c_i\}$ and Y . Then G contains $\binom{u}{\text{id}}$.*

Proof. Let A be an arbitrary finite subset of D that consists of the elements $a_1 < \dots < a_k$. Let $1 \leq j \leq k$ be arbitrary. There exists $\delta \in \text{Aut}(\Delta)$ which maps $\{a_1, \dots, a_{j-1}\}$ into X , a_j to c_i , and $\{a_{j+1}, \dots, a_k\}$ into Y . Hence, application of $f \circ \delta$ flips the graph relation between $\{a_j\}$ and $\{a_{j+1}, \dots, a_k\}$, and keeps the graph relation otherwise on A . Now if we fix any $1 \leq m \leq k$ and apply this process iteratively to all $m \leq j \leq k$, we get that the graph relation is flipped on $\{a_m, \dots, a_k\}$, kept on $\{a_1, \dots, a_{m-1}\}$, and kept between $\{a_1, \dots, a_{m-1}\}$ and $\{a_m, \dots, a_k\}$. Hence, $\binom{u}{\text{id}}$ is generated by f . \square

Lemma 51. *Let $G \supseteq \text{Aut}(\Delta)$ be a closed group, and let $f: (\Delta, c_1, \dots, c_n) \rightarrow \Delta$ be an order preserving canonical function generated by G , where $c_1, \dots, c_n \in D$. Assume that there exists $1 \leq i \leq n$ such that f keeps the graph relation on $D \setminus \{c_1, \dots, c_n\}$, and such that f flips the graph relation between $\{c_i\}$ and $D \setminus \{c_1, \dots, c_n\}$. Then G contains $\binom{\text{sw}}{\text{id}}$.*

Proof. There exists a self-embedding e of Δ which fixes c_i and whose range is contained in $D \setminus \{c_1, \dots, c_{i-1}, c_{i+1}, \dots, c_n\}$. Then $f \circ e$ flips edges and non-edges between $\{c_i\}$ and its complement, and keeps the edge relation on this complement. \square

5.4. Fitting behaviors with groups.

Definition 52. Let $c_1, \dots, c_n \in D$, and let B be a behavior between $(\Delta, c_1, \dots, c_n)$ and Δ . Let moreover $C \supseteq \text{Aut}(\Delta)$ be a closed group. We say that

- B forces C iff every canonical function $f: (\Delta, c_1, \dots, c_n) \rightarrow \Delta$ satisfying B generates all functions in C ;
- B is compatible with C iff there exists a canonical function $f: (\Delta, c_1, \dots, c_n) \rightarrow \Delta$ satisfying B which preserves all relations invariant under C ;

- B fits C iff B forces C and B is compatible with C .

Now let \mathcal{S} be a set of closed groups above $\text{Aut}(\Delta)$. Then we say that

- B is \mathcal{S} -fittable iff there exists a closed group C in \mathcal{S} such that B fits C ;
- B is fittable iff there exists a closed group $C \supseteq \text{Aut}(\Delta)$ such that B fits C .

We will use the above terminology mainly for specific sets of type conditions satisfied by canonical functions from $(\Delta, c_1, \dots, c_n)$ to Δ .

Definition 53. Let $c_1, \dots, c_n \in D$, let $f: (\Delta, c_1, \dots, c_n) \rightarrow \Delta$ be canonical, and let $k \geq 1$. Then we call any restriction of the behavior of f (i.e., the set of type conditions satisfied by f) to types involving k fixed infinite 1-types a k -constellation of f .

For example, if X and Y are infinite orbits of $(\Delta, c_1, \dots, c_n)$, then the set of all type conditions satisfied by f which say something about its behavior on $X \cup Y$ is a 2-constellation of f .

Lemma 54. Let $c_1, \dots, c_n \in D$, let $f: (\Delta, c_1, \dots, c_n) \rightarrow \Delta$ be canonical, and let B be a k -constellation of f , where $k \geq 1$. Then B is compatible with a given closed group $C \supseteq \text{Aut}(\Delta)$ if and only if it preserves all relations invariant under C on the union of the orbits concerned by B .

Proof. Write S for the union of the orbits concerned by B , and Γ for the structure on D whose relations are precisely those invariant under C . Clearly, if B is compatible with C , then f preserves all relations of Γ on S . Assume now the latter; we have to show that there exists a canonical function $g: (\Delta, c_1, \dots, c_n) \rightarrow \Delta$ which preserves all relations of Γ and satisfies B . Let T be the set of finite partial functions on D which preserve all relations of Γ and satisfy B . We claim that every finite $A \subseteq D$ is the domain of a function in T . To see this, consider the restriction of f to $A \cap S$, which is a partial isomorphism on Γ ; by the homogeneity of Γ , it extends to an automorphism α of Γ , and the restriction of α to A is an element of T . Note that if $t \in T$ and $\beta \in \text{Aut}(\Delta)$, then $\beta \circ t \in T$. Hence, by the same standard compactness argument needed to prove Lemma 20, there exists a function $h: D \rightarrow D$ whose restriction to any finite subset of D is an element of T . We then have that h preserves the relations of Γ and satisfies B . By Proposition 10,

$$\overline{\{\alpha \circ h \circ \beta \mid \alpha \in \text{Aut}(\Delta), \beta \in \text{Aut}(\Delta, c_1, \dots, c_n)\}}$$

contains a canonical function g which obviously still preserves the relations of Γ and satisfies B , proving the lemma. \square

The remainder of this section is devoted to the proof of the following lemma, which, as we will show immediately, implies Proposition 29. Recall that together with Proposition 12, which we proved in Section 4, we then obtain a complete proof of Proposition 3.

Lemma 55. Let $1 \leq k \leq 4$, and let B be a k -constellation of an order preserving canonical function $f: (\Delta, c_1, \dots, c_n) \rightarrow \Delta$, where $c_1, \dots, c_n \in D$. Then B is OP-fittable.

In the following lemma, we are given a canonical function $f: (\Delta, c_1, \dots, c_n) \rightarrow \Delta$ and a closed group C which can locally invert the effect of f on a fixed collection of infinite orbits; the lemma roughly states that we can then produce from f and C a canonical function which behaves like the identity function on the collection.

Lemma 56. Let

- $C \supseteq \text{Aut}(\Delta)$ be a closed group;
- $f: (\Delta, c_1, \dots, c_n) \rightarrow \Delta$ be a canonical function, where $c_1, \dots, c_n \in D$;
- B be a k -constellation of f which is compatible with C .

Then

$$\overline{\{\gamma \circ f \circ \beta \mid \gamma \in C, \beta \in \text{Aut}(\Delta, c_1, \dots, c_n)\}}$$

contains a canonical function $g: (\Delta, c_1, \dots, c_n) \rightarrow \Delta$ whose restriction to the union of the orbits concerned by B behaves as the identity function does (i.e., that restriction is a partial self-embedding of Δ).

Proof. Let S be the union of the infinite orbits of $(\Delta, c_1, \dots, c_n)$ concerned by B . Let Γ be the structure whose relations are those preserved by the permutations in C . Clearly, Γ is homogeneous, and the restriction of f to any finite subset of S is a partial isomorphism of Γ whose inverse extends to an element of C . Consider the set T of all partial functions p such that

- p is the restriction of a function of the form $\gamma \circ f$, where $\gamma \in C$, to some finite subset of D ;
- p behaves as the identity function does on the intersection of its domain with S .

By the above observation, every finite subset of D is the domain of a function in T . Since Γ is ω -categorical, by Lemma 20 there exists a function h in $\overline{\{\gamma \circ f \mid \gamma \in C\}}$ which behaves like the identity function on S . Now Proposition 10 tells us that

$$\overline{\{\alpha \circ h \circ \beta \mid \alpha \in \text{Aut}(\Delta), \beta \in \text{Aut}(\Delta, c_1, \dots, c_n)\}}$$

contains a canonical function $g: (\Delta, c_1, \dots, c_n) \rightarrow \Delta$; clearly, the restriction of this function to S still behaves as the identity function does. \square

Definition 57. Let Λ, Ω be structures, and let B be a behavior between Λ and Ω . Then we call any subset of B a *subbehavior* of B . If B is a k -constellation, and $B' \subseteq B$ is an m -constellation, then we will call B' an *m -subconstellation* of B .

Lemma 58. *Let $C \supseteq \text{Aut}(\Delta)$ be the automorphism group of a homogeneous structure in an m -ary relational language, where $m \geq 1$. Let $f: (\Delta, c_1, \dots, c_n) \rightarrow \Delta$ be a canonical function, where $c_1, \dots, c_n \in D$. If $k \geq m$, then a k -constellation of f is compatible with C if and only if its m -subconstellations are compatible with C .*

Proof. Let B be any k -constellation of f , where $k \geq m$. If B is compatible with C , then trivially so are its m -subconstellations. For the converse, let S be the union of the orbits concerned by B ; we claim that f preserves all relations invariant under C on S . Otherwise, f would violate an m -ary relation R invariant under C , since C is homogeneous in an m -ary relational language. So there would be a tuple (a_1, \dots, a_m) of elements in S such that $(a_1, \dots, a_m) \in R$ and $(f(a_1), \dots, f(a_m)) \notin R$. Writing O_i for the orbit of a_i , for all $1 \leq i \leq m$, we would then have that any m -constellation of f concerning all of the O_i would be incompatible with C , a contradiction. Hence, f indeed preserves all relations invariant under C on S , and so we are done by Lemma 54. \square

We are now ready to prove Proposition 29 (assuming the truth of Lemma 55).

Proof of Proposition 29. Let M be the largest group in OP that is contained in G ; in other words, M is the join of $\text{Aut}(\Delta)$ and all groups in JI° contained in G . Let Γ be the homogeneous structure in a 4-ary language such that $M = \text{Aut}(\Gamma)$, guaranteed by Proposition 30.

Suppose that f has a 4-constellation B which is not compatible with M . By Lemma 55, B is OP-fittable; let $C \in \text{OP}$ be so that B fits C . Since B forces C , we have that H contains C . On the other hand, since B is compatible with C , we have that C cannot be contained in M : otherwise, since B is not compatible with M , it would not be compatible with C either. By the definition of M , we conclude that C is not contained in G either, and so we are done.

We may thus assume that all 4-constellations of f are compatible with M ; by Lemmas 58 and 56, there is a canonical function $g: (\Delta, c_1, \dots, c_n) \rightarrow \Delta$ which is not generated by G and whose restriction to $D \setminus \{c_1, \dots, c_n\}$ behaves like the identity function. By canonicity, we have that g keeps or flips the graph relation between any $\{c_i\}$ and any infinite orbit; using Lemma 48 we may even assume that g keeps or flips the graph relation between any $\{c_i\}$ and any level of $(\Delta, c_1, \dots, c_n)$.

Assume that there exist $1 \leq i \leq n$ and two levels such that g keeps the graph relation between $\{c_i\}$ and one of them, and g flips the graph relation between $\{c_i\}$ and the other. There exist two levels L_1, L_2 such that $L_1 < \{c_i\} < L_2$, such that g keeps the graph relation between $\{c_i\}$ and one of them, and such that g flips the graph relation between $\{c_i\}$ and the other. Assume without loss of generality that g keeps the graph relation between $\{c_i\}$ and L_1 . Then H contains $\binom{u}{\text{id}}$ by Lemma 50. If $\binom{u}{\text{id}} \notin G$ then we are done, so we may assume that $\binom{u}{\text{id}} \in G$. Then it is easy to see that G generates a canonical function $h: (\Delta, c_i) \rightarrow \Delta$ which preserves the order, which flips the graph relation between $g(c_i)$ and all $d \in D$ with $g(c_i) < d$, and which keeps the graph relation otherwise. By Lemma 49, we may assume that g keeps the graph relation between a level L and $\{c_i\}$ if and only if $L < \{c_i\}$. Replacing g by $h \circ g$ we then may assume that g keeps the graph relation between $\{c_i\}$ and the union of all infinite orbits. Repeating this process for all $1 \leq i \leq n$, we then have that for each i the function g keeps or flips the graph relation between $\{c_i\}$ and the union of all infinite orbits.

Assume now that there exists $1 \leq i \leq n$ such that g flips the graph relation between $\{c_i\}$ and the union of all infinite orbits. Then H contains $\binom{\text{sw}}{\text{id}}$ by Lemma 51, and we may assume that G contains this function as well, for otherwise we are done. Then it is easy to see that G generates a canonical function $h: (\Delta, c_i) \rightarrow \Delta$ which preserves the order, which flips the graph relation between $g(c_i)$ and its complement, and which keeps the graph relation otherwise. Replacing g by $h \circ g$ we then may assume that g keeps the graph relation between $\{c_i\}$ and the union of all infinite orbits. Repeating this process for all $1 \leq i \leq n$, we then have that for each i the function g keeps or flips the graph relation between $\{c_i\}$ and the union of all infinite orbits.

We now continue with this assumption, i.e., if $x, y \in D$ are so that the edge relation is altered between x and y , then $x, y \in \{c_1, \dots, c_n\}$. As g violates a relation definable in Δ , there exist $1 \leq i < j \leq n$ such that the graph relation is flipped between $\{c_i\}$ and $\{c_j\}$. Using Lemma 22, it is then straightforward to see that H contains $\text{Aut}(D; <)$. \square

5.5. Fitting the constellations. We will now prove Lemma 55 by considering all possible k -constellations B , for $1 \leq k \leq 4$. For every such B we find a group $C \in \text{OP}$ such that B fits C . From $k = 2$ on, we will draw a picture describing B , and the corresponding group C will be indicated in the lower right corner. The proof that a constellation B fits a group C consists of two parts: proving that B forces C and proving that B is compatible with C . Verifying compatibility can be automated using Lemma 54, and we shall omit these verifications: for example, to verify that $R^{(3)}$ is preserved, one has to consider all 3-element ordered graphs, distribute their vertices in all possible ways among the orbits, and check that the modification of the graph relations according to the behavior really agrees with $R^{(3)}$ in all these cases.

Of course, the number of k -constellations grows with k , and we will be obliged to systematically use knowledge on smaller constellations (i.e., $(k-1)$ -subconstellations). An example of this is the following easy but useful observation concerning constellations which fit the specific group $\text{Aut}(D; <)$; since they appear often in our analysis, it is convenient to give them their own name.

Definition 59. We call a k -constellation of an order preserving canonical function $f: (\Delta, c_1, \dots, c_n) \rightarrow \Delta$ *full* iff it fits $\text{Aut}(D; <)$.

Lemma 60. *Let $f: (\Delta, c_1, \dots, c_n) \rightarrow \Delta$ be canonical and order preserving. Then any k -constellation of f with a subconstellation forcing $\text{Aut}(D; <)$ also fits $\text{Aut}(D; <)$ (and in particular, is full and OP-fittable).*

Proof. Clearly such a constellation forces $\text{Aut}(D; <)$; because f is order preserving, it also is compatible with $\text{Aut}(D; <)$. \square

As a consequence, once we know that a certain $(k-1)$ -constellation forces $\text{Aut}(D; <)$, we only have to consider k -constellations which do not have this constellation as a subconstellation, reducing the number of cases.

Another lemma that reduces the number of cases is the following.

Lemma 61. *Let $f: (\Delta, c_1, \dots, c_n) \rightarrow \Delta$ be an order preserving canonical function, and let B be a k -constellation of f . Let S be the union over all orbits concerned by B . Suppose that B has a subconstellation fitting a group C , suppose there is a canonical function in*

$$\overline{\{\gamma \circ f \circ \beta \mid \gamma \in C, \beta \in \text{Aut}(\Delta, c_1, \dots, c_n)\}}$$

whose restriction to S has an OP-fittable behavior B' . Then B is OP-fittable.

Proof. Let C' fit B' . Clearly, B forces $C \vee C'$. On the other hand, suppose that R is a relation which is invariant under $C \vee C'$ and which is violated by f on S . Then note that all functions of the form $f \circ \beta$, where $\beta \in \text{Aut}(\Delta, c_1, \dots, c_n)$, violate R on precisely the same sets as f , since they all have the same behavior. Because R is invariant under C , even all functions of the form $\gamma \circ f \circ \beta$, where $\gamma \in C$ and $\beta \in \text{Aut}(\Delta, c_1, \dots, c_n)$, violate R on precisely the same sets as f . Hence, any function in the closure of the set of such functions violates R on S . But this contradicts the assumption that R is invariant under C' , proving that B is compatible with $C \vee C' \in \text{OP}$. \square

Lemma 62. *Assume that all $(k-1)$ -constellations of order preserving canonical functions are OP-fittable. Assume moreover that all k -constellations of order preserving canonical functions which have a $(k-1)$ -subconstellation with the behavior of the identity function are OP-fittable. Then all k -constellations of order preserving canonical functions are OP-fittable.*

Proof. Let B be a k -constellation of an order preserving canonical function $f: (\Delta, c_1, \dots, c_n) \rightarrow \Delta$, and let B' be an arbitrary $(k-1)$ -subconstellation. Then B' is OP-fittable by assumption; let $C \in \text{OP}$ be so that B' fits C . Let S be the union of the orbits concerned by B , and S' the union of those concerned by B' . By Lemma 56, there exists a canonical $g \in \overline{\{\gamma \circ f \circ \beta \mid \gamma \in C, \beta \in \text{Aut}(\Delta, c_1, \dots, c_n)\}}$ which behaves like the identity function on S' . The constellation given by S for g is OP-fittable by assumption, and so B is OP-fittable by Lemma 61. \square

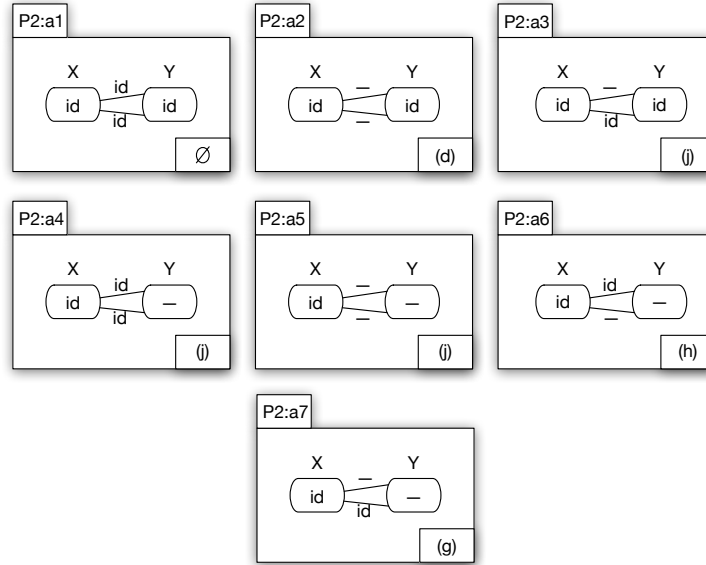

FIGURE 4. Cases C2:a

5.5.1. *Fitting the 1-constellations.* Clearly, all 1-constellations fit either $\text{Aut}(D; <)$ (when eradicating edges or non-edges; cf. Lemma 23), or $\langle (\overline{\text{id}}) \rangle$ (when flipping the graph relation), or $\text{Aut}(\Delta)$ (when keeping the graph relation).

5.5.2. *Fitting the 2-constellations.* We first treat the 16 different 2-constellations with the two orbits on the same level. Figure 4 lists all those constellations up to symmetry with the behavior id on X (see Lemma 62 with $k = 2$ and $S' = X$). As we have mentioned, we only verify that each of these 2-constellations B forces the group C indicated in the lower right of the respective picture. In each case, f denotes a canonical function from $(\Delta, c_1, \dots, c_n)$ to Δ satisfying B , and we have to show that f generates all functions in C . On these pictures, X and Y are orbits, and the two lines connecting them indicate two different kinds of pairs $(x, y) \in X \times Y$: those with $x < y$ indicated by the ascending line and those with $x > y$ by the descending one. The signs id and $-$ written in the orbits or on the lines specify the behavior of f , where $-$ corresponds to the behavior of $(\overline{\text{id}})$.

C2:a1. There is nothing to prove, every function “generates” $\text{Aut}(\Delta)$ by definition.

C2:a2. Let A be an arbitrary finite subset of D and let $S \subseteq A$. There exists a $\gamma \in \text{Aut}(\Delta)$ such that $\gamma[S] \subseteq X$ and $\gamma[A \setminus S] \subseteq Y$. Then $f \circ \gamma$ flips the graph relation between S and $A \setminus S$, and keeps it otherwise on A . Thus, f generates $(\overline{\text{id}})^{\text{sw}}$.

C2:a3, C2:a4, C2:a5. Let A be an arbitrary finite subset of D that consists of the elements $a_1 < \dots < a_k$. Let $1 \leq i < j \leq k$. There exist $\gamma_1, \gamma_2, \gamma_3, \gamma_4 \in \text{Aut}(\Delta)$ such that

- $\gamma_1[A] \subseteq X$,
- $\gamma_2[A \setminus \{a_i\}] \subseteq X$, $\gamma_2(a_i) \in Y$,
- $\gamma_3[A \setminus \{a_j\}] \subseteq X$, $\gamma_3(a_j) \in Y$,
- $\gamma_4[A \setminus \{a_i, a_j\}] \subseteq X$, $\gamma_4[\{a_i, a_j\}] \subseteq Y$.

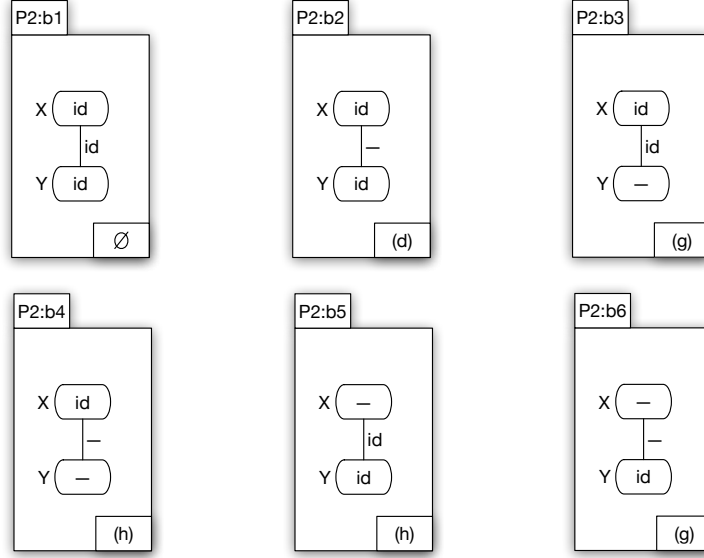

FIGURE 5. Cases C2:b

We would like to ‘combine’ the four behaviors $f \circ \gamma_i$, for $i \in \{1, 2, 3, 4\}$, in order to flip the graph relation on the pair (a_i, a_j) and to keep it otherwise on A . To formalize this, we choose $\delta_1, \delta_2, \delta_3, \delta_4 \in \text{Aut}(\Delta)$ such that

- $\delta_1[A] \subseteq X$,
- $\delta_2 \circ f \circ \delta_1[A \setminus \{a_i\}] \subseteq X$, $\delta_2 \circ f \circ \delta_1(a_i) \in Y$,
- $\delta_3 \circ f \circ \delta_2 \circ f \circ \delta_1[A \setminus \{a_j\}] \subseteq X$, $\delta_3 \circ f \circ \delta_2 \circ f \circ \delta_1(a_j) \in Y$,
- $\delta_4 \circ f \circ \delta_3 \circ f \circ \delta_2 \circ f \circ \delta_1[A \setminus \{a_i, a_j\}] \subseteq X$, $\delta_4 \circ f \circ \delta_3 \circ f \circ \delta_2 \circ f \circ \delta_1[\{a_i, a_j\}] \subseteq Y$.

Consider now $f \circ \delta_4 \circ f \circ \delta_3 \circ \dots \circ \delta_1$; this function indeed flips the graph relation on the pair (a_i, a_j) and otherwise behaves as the identity on A . One can now use Lemma 22 to show that f generates $\text{Aut}(D; <)$.

C2:a6. Let A be an arbitrary finite subset of D and let $S \subseteq A$ be an upward closed subset. There exists a $\gamma \in \text{Aut}(\Delta)$ such that $\gamma[S] \subseteq Y$ and $\gamma[A \setminus S] \subseteq X$. Then $f \circ \gamma$ flips the graph relation on S and keeps it otherwise on A . Thus, f generates $\binom{u}{\text{id}}$.

C2:a7. This can be shown analogously to the previous case.

We now discuss the 2-constellations with the two orbits on different levels. There are eight such constellations. We do not consider those which have the behavior of $\binom{-}{\text{id}}$ in both orbits (see Lemma 62), the rest of the cases are illustrated in Figure 5.

C2:b1. There is nothing to prove, every function generates $\text{Aut}(\Delta)$.

C2:b2. Let A be an arbitrary finite subset of D that consists of the elements $a_1 < \dots < a_k$. Let $1 \leq i \leq k$. Let $A_1 = \{a_1, \dots, a_{i-1}\}$, $A_2 = \{a_{i+1}, \dots, a_k\}$. There exists a $\gamma \in \text{Aut}(\Delta)$ such that $\gamma[A_1] \subseteq X$, $\gamma(a_i) \in X$, and $\gamma[A_2] \subseteq Y$. We can also choose $\delta \in \text{Aut}(\Delta)$ such that $\delta(a_i) \in Y$, $\delta[A_1] \subseteq X$, and $\delta[A_2] \subseteq Y$. Then combining the effect of $f \circ \delta$ and of $f \circ \gamma$ (formalized as in case C2:a3), we obtain a function that flips the graph relation between $\{a_i\}$ and $A \setminus \{a_i\}$ and keeps it otherwise on A . Hence, f generates $\binom{\text{sw}}{\text{id}}$.

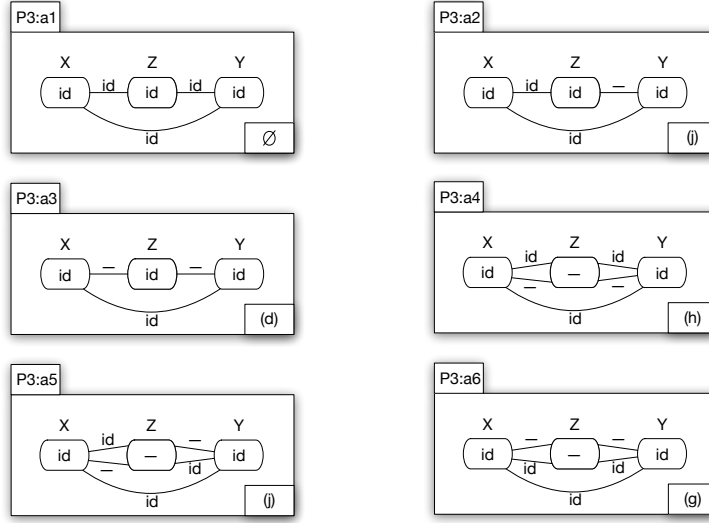

FIGURE 6. Cases C3:a

C2:b3. Let A be an arbitrary finite subset of D that consists of the elements $a_1 < \dots < a_k$. Let $S \subseteq A$ be a downward closed subset. There exists a $\gamma \in \text{Aut}(\Delta)$ such that $\gamma[S] \subseteq Y$ and $\gamma[A \setminus S] \subseteq X$. Then $f \circ \gamma$ flips the graph relation on S and keeps it otherwise on A . Thus, f generates $\binom{l}{\text{id}}$.

C2:b5. Analogously to the previous case it can be shown that f generates $\binom{u}{\text{id}}$.

C2:b4. As f behaves like $\binom{-}{\text{id}}$ on Y we have that f generates $\binom{-}{\text{id}}$. By composing $\binom{-}{\text{id}}$ with f we obtain a constellation as in C2:b5, hence f generates $\binom{u}{\text{id}}$.

C2:b6. As f behaves like $\binom{-}{\text{id}}$ on X we have that f generates $\binom{-}{\text{id}}$. By composing $\binom{-}{\text{id}}$ with f we obtain a constellation as in C2:b3, hence f generates $\binom{l}{\text{id}}$.

5.5.3. *Fitting the 3-constellations.* We check the 3-constellations according to the following case distinction: either all three orbits are on the same level, or two of them are on the same level, or all three orbits are on different levels. In each of these cases, we may refer to Lemma 62 and assume that for two orbits X, Y of our choice we have the identity behavior on and between X and Y . There are eight 3-constellations with all three orbits X, Y, Z on the same level with the identity behavior on and between X and Y , and such that the constellation does not contain a full 2-subconstellation. We only need to consider these 3-constellations up to symmetry of X and Y , which leads to six cases, drawn in Figure 6.

C3:a1. There is nothing to prove, every function generates $\text{Aut}(\Delta)$.

C3:a2. Let A be an arbitrary finite subset of D that consists of the elements $a_1 < \dots < a_k$. Let $1 \leq i < j \leq k$. There exists a $\gamma \in \text{Aut}(\Delta)$ such that $\gamma(a_i) \in Z$, $\gamma(a_j) \in Y$ and $\gamma[A \setminus \{a_i, a_j\}] \subseteq X$. Then $f \circ \gamma$ flips the graph relation between a_i and a_j , and keeps it otherwise on A . Thus, f generates $\text{Aut}(D; <)$.

C3:a3. The constellation induced by $X \cup Z$, treated in C2:a2, shows that f generates $\binom{\text{sw}}{\text{id}}$.

C3:a4. The constellation induced by $X \cup Z$, treated in C2:a6, shows that f generates $\binom{u}{\text{id}}$.

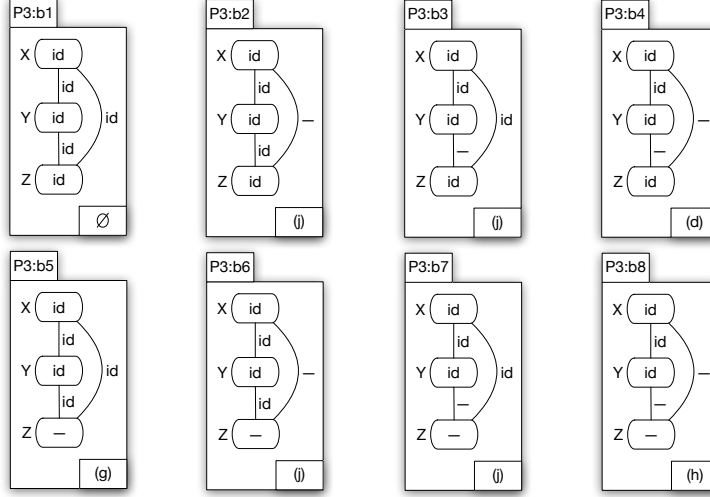

FIGURE 7. Cases C3:b

C3:a5. Let A be an arbitrary finite subset of D that consists of the elements $a_1 < \dots < a_k$. Let $1 \leq i < j \leq k$. Let $A_1 = \{a_1, \dots, a_{i-1}\}$, $A_2 = \{a_{i+1}, \dots, a_{j-1}\}$, and $A_3 = \{a_{j+1}, \dots, a_k\}$. There exist $\gamma_1, \gamma_2, \gamma_3 \in \text{Aut}(\Delta)$ such that

- $\gamma_1[A_1] \subseteq X$, $\gamma_1[A_2] \subseteq Z$, $\gamma_1[A_3] \subseteq Y$,
- $\gamma_2[A_1] \subseteq Z$, $\gamma_2[A_2] \subseteq Y$, $\gamma_2[A_3] \subseteq X$,
- $\gamma_3[A_1] \subseteq Y$, $\gamma_3[A_2] \subseteq X$, $\gamma_3[A_3] \subseteq Z$, and
- $\gamma_m(a_i), \gamma_m(a_j) \in Z$ for $m \in \{1, 2, 3\}$.

Then the combined effect of $f \circ \gamma_i$ for $m \in \{1, 2, 3\}$ (for a formalization of this, see case C2:a3) flips the graph relation between a_i and a_j , and keeps it otherwise on A . Thus, f generates $\text{Aut}(D; <)$.

C3:a6. The constellation induced by $X \cup Z$, treated in C2:a7, shows that f generates $\binom{l}{\text{id}}$.

Figure 7 contains the 3-constellations with orbits $X > Y > Z$, such that the behavior is identical on and between X and Y , and the constellation does not have a full 2-subconstellation.

C3:b1. There is nothing to prove, every function generates $\text{Aut}(\Delta)$.

C3:b2. Let A be an arbitrary finite subset of D that consists of the elements $a_1 < \dots < a_k$. Let $1 \leq i < j \leq k$. Let $A_1 = \{a_1, \dots, a_{i-1}\}$, $A_2 = \{a_{i+1}, \dots, a_{j-1}\}$, $A_3 = \{a_{j+1}, \dots, a_k\}$. There exist $\gamma_1, \gamma_2, \gamma_3, \gamma_4 \in \text{Aut}(\Delta)$ such that

- $\gamma_m(A_1) \subseteq Z$, $\gamma_m(A_2) \subseteq Y$, $\gamma_m(A_3) \subseteq X$ for $m = 1, 2, 3, 4$
- $\gamma_1(a_i) \in Z$, $\gamma_1(a_j) \in Y$,
- $\gamma_1(a_i) \in Y$, $\gamma_1(a_j) \in Y$,
- $\gamma_1(a_i) \in Z$, $\gamma_1(a_j) \in X$,
- $\gamma_1(a_i) \in Y$, $\gamma_1(a_j) \in X$.

By combining the effect of the functions $f \circ \gamma_m$, for $m \in \{1, 2, 3, 4\}$ (as formalized in C2:a3) we obtain a function that flips the graph relation between a_i and a_j , and keeps it otherwise on A . Thus, f generates $\text{Aut}(D; <)$.

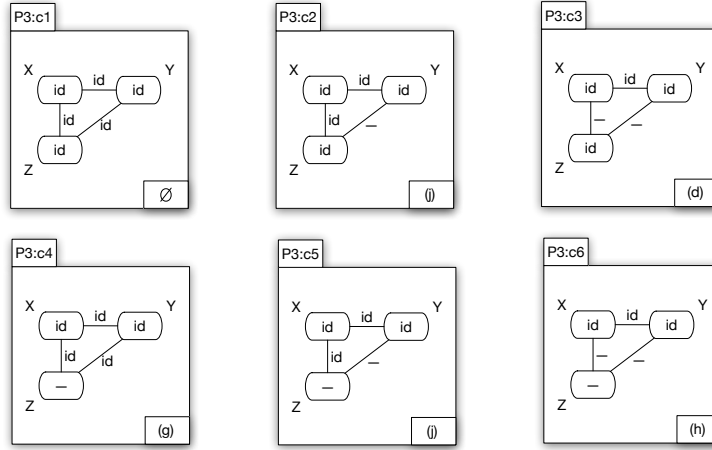

FIGURE 8. Cases C3:c

C3:b3. The constellation induced by $Y \cup Z$ shows that f generates $\binom{sw}{id}$. By applying an order preserving permutation that flips the graph relation between Z and its complement, we arrive at C3:b2. Hence, f generates $\text{Aut}(D; <)$.

C3:b4. The constellation induced by $Y \cup Z$, treated in C2:b2, shows that f generates $\binom{sw}{id}$.

C3:b5. The constellation induced by $Y \cup Z$, treated in C2:b3, shows that f generates $\binom{l}{id}$.

C3:b6. Let A be an arbitrary finite subset of D that consists of the elements $a_1 < \dots < a_k$. Let $1 \leq i < j \leq k$. Let $A_1 = \{a_1, \dots, a_{i-1}\}$, $A_2 = \{a_{i+1}, \dots, a_{j-1}\}$, $A_3 = \{a_{j+1}, \dots, a_k\}$. There exist $\gamma_1, \gamma_2, \gamma_3, \gamma_4 \in \text{Aut}(\Delta)$ such that $\gamma_m[A_1] \subseteq Z$, $\gamma_m[A_2] \subseteq Y$, $\gamma_m[A_3] \subseteq X$ for $m = 1, 2, 3, 4$, and $\gamma_m(a_i)$ is in X or in Y and $\gamma_m(a_j)$ is in Y or Z such that all four possibilities occur once. Then the combined effect of $f \circ \gamma_m$ for $m \in \{1, 2, 3, 4\}$ (as formalized in C2:a3) flips the graph relation between a_i and a_j , and keeps it otherwise on A . Thus, f generates $\text{Aut}(D; <)$.

C3:b7. There exists some $\gamma \in \text{Aut}(\Delta)$ such that $\gamma[f[X] \cup f[Y]] \subseteq Y$ and $\gamma[f[Z]] \subseteq Z$. Then $f \circ \gamma \circ f$ has the same constellation as in C3:b2. Hence, f generates $\text{Aut}(D; <)$.

C3:b8. The constellation induced by $Y \cup Z$, treated in C2:b4, shows that f generates $\binom{u}{id}$.

Figure 8 shows the 3-constellations with orbits X, Y, Z such that X and Y are on the same level, $Z < X$, the behavior is identical on and between X and Y , and the constellation does not contain a full 2-subconstellation. Note that the cases C3:c have the same group in the right lower corner than the corresponding cases in C3:b. And indeed, it is easy to see that each case in C3:c forces at least the groups that are forced by the corresponding constellation in C3:b.

Figure 9 contains the 3-constellations with orbits X, Y, Z such that X and Y are on the same level, $Z > X$, the behavior is identical on and between X and Y , and the constellation does not contain a full 2-subconstellation. The situation here is analogous to the Cases C3:c.

5.5.4. *Fitting the 4-constellations.* Observe that so far, every k -constellation which is identical on all orbits has been either full or compatible with $R^{(3)}$. This leads to the following simplification which reduces the number of 4-constellations to consider.

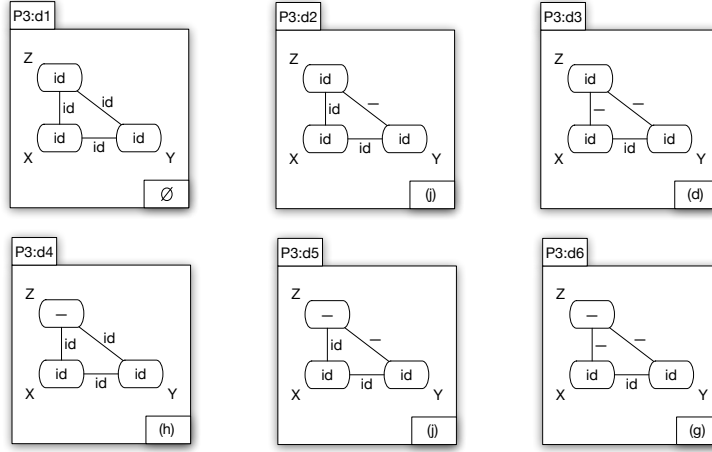

FIGURE 9. Cases C3:d

Lemma 63. *Let $k \geq 1$ and let B be a k -constellation of an order preserving canonical function $f: (\Delta, c_1, \dots, c_n) \rightarrow \Delta$. If the restriction of B to any orbit is the identical behavior, then B is OP-fittable.*

Proof. According to Lemma 60 we may assume that B has no subconstellation that forces $\text{Aut}(D; <)$. By Lemma 24 we may moreover assume that B either keeps or flips the graph relation between any two orbits, or otherwise it is full. If B is identical between any pair of orbits, then B fits $\text{Aut}(\Delta)$. Hence, we may assume that there exist two orbits such that the behavior of B flips the graph relation between them. According to the Cases C2:a2 and C2:b2 we have that B forces $\langle \langle \text{id}^{\text{sw}} \rangle \rangle$. Assume that B violates $R^{(3)}$. As $R^{(3)}$ is a ternary relation, there exist three orbits X, Y, Z such that the subconstellation B' induced by $X \cup Y \cup Z$ violates $R^{(3)}$. So B' has the identity behavior on every orbit, and violates $R^{(3)}$; according to the case-by-case analysis of the 3-constellations, we have that all such B' are full. Thus, B is compatible with $R^{(3)}$, and so B fits $\text{Aut}(D; R^{(3)}) = \langle \langle \text{id}^{\text{sw}} \rangle \rangle$. \square

We check the 4-constellations according to a similar case distinction as before. In all the cases we may refer to Lemma 62 and choose three orbits for which we assume that the behavior is identical on and between them. According to Lemma 63 we may assume that the behavior flips the graph relation on the remaining fourth orbit. We only analyze those constellations which do not contain a subconstellation forcing $\text{Aut}(D; <)$ – see Lemma 60.

Figure 10 contains the remaining 4-constellations with all orbits on the same level. There are only two constellations to be checked as we assume that the behavior is identical on and between X, Y, Z , flips the graph relation on W , and that there is no full subconstellation. In particular, any 3-subconstellation belongs to one of the Cases C3:a1, C3:a4, C3:a6.

C4:a1. The constellation induced by $Z \cup W$, treated in C2:a7, shows that f generates $\langle \langle \text{id}^l \rangle \rangle$.

C4:a2. The constellation induced by $Z \cup W$, treated in C2:a6, shows that f generates $\langle \langle \text{id}^u \rangle \rangle$.

Figure 11 shows the relevant 4-constellations with three orbits X, Y, Z on the same level and the fourth orbit $W < X$. There are only two constellations to be checked as we assume that the behavior is identical on and between X, Y, Z , flips the graph relation on W , and that

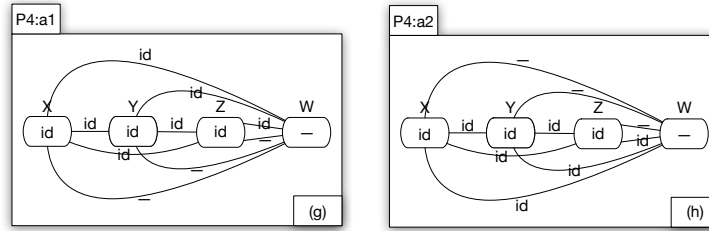

FIGURE 10. Cases C4:a

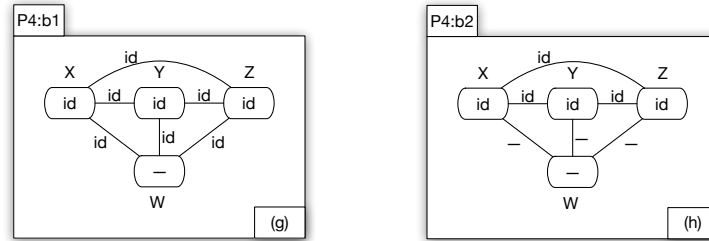

FIGURE 11. Cases C4:b

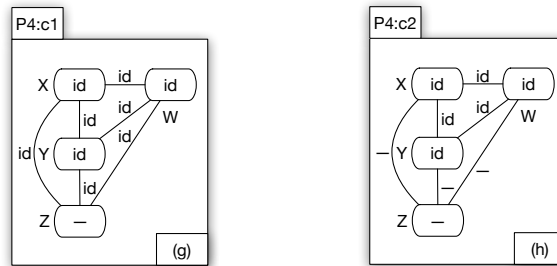

FIGURE 12. Cases C4:c

there is no full subconstellation. In particular, either the graph relation is kept everywhere else, or the graph relation is flipped everywhere else.

C4:b1. The constellation induced by $X \cup W$, treated in C2:b3, shows that f generates $\binom{l}{id}$.

C4:b2. The constellation induced by $X \cup W$, treated in C2:b4, shows that f generates $\binom{u}{id}$.

The case with X, Y, Z on the same level and the fourth orbit $W > X$ is analogous to the previous case, Case C4b, and we omit it. Figure 12 contains the relevant 4-constellations with three orbits $X > Y > Z$ and the fourth orbit W on the same level as X . There are only two constellations to be checked as we assume that the behavior is identical on and between X, Y, W , flips the graph relation on Z , and that there is no full subconstellation. In particular, either the graph relation is kept everywhere else, or the graph relation is flipped everywhere else.

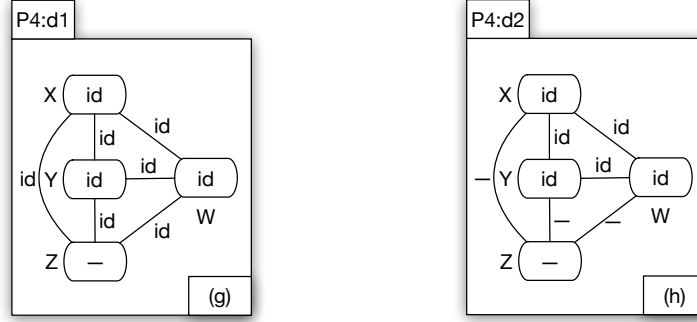

FIGURE 13. Cases C4:d

- C4:c1. The constellation induced by $Z \cup W$, treated in C2:b3, shows that f generates $\begin{pmatrix} l \\ \text{id} \end{pmatrix}$.
 C4:c2. The constellation induced by $Z \cup W$, treated in C2:b4, shows that f generates $\begin{pmatrix} u \\ \text{id} \end{pmatrix}$.

The case with $X > Y > Z$ and the fourth orbit W on the same level as Z is analogous to the previous case, Case C4:c, so we omit it. Figure 13 contains the relevant 4-constellations with three orbits $X > Y > Z$ and the fourth orbit W on the same level as Y . There are only two constellations to be checked as we assume that the behavior is identical on and between X, Y, W , flips the graph relation on Z , and that there is no full subconstellation. In particular, either the graph relation is kept everywhere else, or the graph relation is flipped everywhere else.

- C4:d1. The constellation induced by $Z \cup W$, treated in C2:b3, shows that f generates $\begin{pmatrix} l \\ \text{id} \end{pmatrix}$.
 C4:d2. The constellation induced by $Z \cup W$, treated in C2:b4, shows that f generates $\begin{pmatrix} u \\ \text{id} \end{pmatrix}$.

Figure 14 contains the relevant 4-constellations with orbits X and Y on the same level, Z and W on the same level, and $X > Z$. There are only four constellations to be checked, because we assume that the behavior is identical on and between X, Y, Z , flips the graph relation on W , and that there is no full subconstellation. In particular, either the graph relation is kept between X and W and between Y and W , or the graph relation is flipped between X and W and between Y and W . There are also two possibilities for the behavior between Z and W according to Subsection 5.5.2, Case C2.

C4:e1. Let B' be the constellation induced by $Y \cup Z \cup W$. Then B' is OP-fittable by Subsection 5.5.3. Consider $a \in W$, $b, c \in Z$, $d \in Y$, such that $a < b < c < d$ and no edges between vertices from $\{a, b, c, d\}$. Then $(a, b, c, d) \in S_4$, and B' violates S_4 on (a, b, c, d) . Thus, B' is full.

C4:e2. The constellation induced by $Z \cup W$, treated in C2:a7, shows that f generates $\begin{pmatrix} l \\ \text{id} \end{pmatrix}$.

C4:e3. The constellation induced by $Z \cup W$, treated in C2:a6, shows that f generates $\begin{pmatrix} u \\ \text{id} \end{pmatrix}$.

C4:e4. Let B' be the subconstellation induced by $Y \cup Z \cup W$. Then B' is OP-fittable by Subsection 5.5.3. Consider $a \in W$, $b, c \in Z$, $d \in Y$, such that $a < b < c < d$ and no edges between vertices from $\{a, b, c, d\}$. Then $(a, b, c, d) \in S_4$, and B' violates S_4 on (a, b, c, d) . Thus, B' is full.

Figure 15 contains the relevant 4-constellations with three orbits $X > Y > Z > W$. There are only two constellations to be checked as we assume that the behavior is identical on and

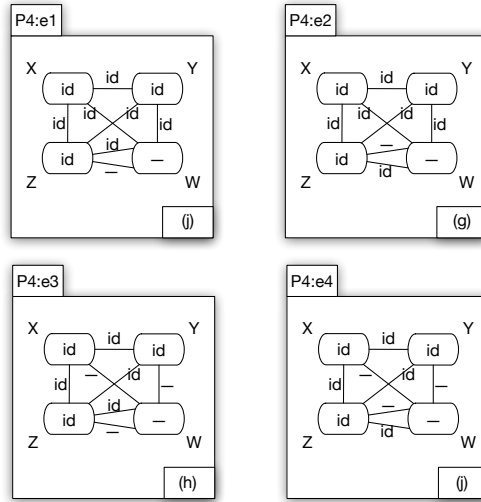

FIGURE 14. Cases C4:e

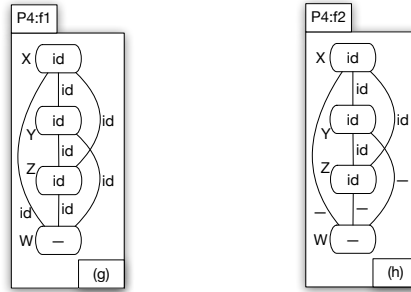

FIGURE 15. Cases C4:f

between X, Y, Z , flips the graph relation on W , and that there is no full subconstellation. In particular, either the graph relation is kept everywhere else, or the graph relation is flipped everywhere else.

C4:f1. The constellation induced by $X \cup W$, treated in C2:b3, shows that f generates $\binom{l}{id}$.

C4:f2. The constellation induced by $X \cup W$, treated in C2:b4, shows that f generates $\binom{u}{id}$.

6. THE 42 REDUCTS

We have so far established that every group in \mathfrak{L} is the join of groups in \mathfrak{JI} (Corollary 4); in particular, we already know that \mathfrak{L} is finite. The goal of this section is to obtain a precise picture of \mathfrak{L} , and a description of all 42 non-trivial proper reducts.

Since all elements of \mathfrak{L} are joins of groups in \mathfrak{JI} , we have in particular that the join irreducibles of \mathfrak{L} are contained in \mathfrak{JI} . Assuming that all elements of \mathfrak{JI} are also join irreducible in \mathfrak{L} , which we are going to see in this section, we then get that the elements of \mathfrak{L} correspond precisely to the *ideals* of \mathfrak{JI} .

Definition 64. A set $\mathcal{I} \subseteq \text{JI}$ is called an *ideal* iff it contains all elements of JI contained in $\bigvee \{H : H \in \mathcal{I}\}$.

It is well-known and easy to see that every finite lattice is isomorphic to the lattice of ideals of its join irreducibles. We therefore have the following.

Proposition 65. *The lattice \mathfrak{L} of closed supergroups of $\text{Aut}(\Delta)$ is isomorphic to the lattice of ideals of JI with the order of inclusion.*

It will be convenient to represent the ideals of JI by their maximal elements, which makes the following definition useful.

Definition 66. For a set $\mathcal{S} \subseteq \text{JI}$ we write $\text{dcl } \mathcal{S}$ for the *downward closure* of \mathcal{S} in JI , i.e., the subset of those groups in JI which are contained in some group in \mathcal{S} .

We will now systematically list all ideals of JI by their maximal elements. We also identify them by their name in Figure 3.

6.1. Ideals containing $\text{Aut}(D; E)$, $\text{Aut}(D; <)$, or $\text{Aut}(D; T)$. These ideals are easily determined using the existing classifications for the random graph, the rationals, and the random tournament. Recall the names of the elements of JI defined in Figures 1 and 2.

Lemma 67. *The ideals of JI containing $\text{Aut}(D; E)$ are the following:*

- (1) *the trivial ideal JI (ijk);*
- (2) $\text{dcl}\{\text{Aut}(D; E)\}$ (i);
- (3) $\text{dcl}\{\text{Aut}(D; E), \langle \binom{-}{\text{id}} \rangle, \langle \binom{-}{\leftrightarrow} \rangle\}$ (dfi);
- (4) $\text{dcl}\{\text{Aut}(D; E), \langle \binom{\text{sw}}{\text{id}} \rangle, \langle \binom{\text{id}}{\circ} \rangle, \langle \binom{\text{sw}}{\circ} \rangle\}$ (cei);
- (5) $\text{dcl}\{\text{Aut}(D; E), \langle \binom{-}{\text{id}} \rangle, \langle \binom{-}{\leftrightarrow} \rangle, \langle \binom{\text{sw}}{\text{id}} \rangle, \langle \binom{\text{sw}}{\circ} \rangle\}$ ($cdefi$).

Proof. This follows from Thomas' classification [Tho91] of the reducts of $\text{Aut}(D; E)$ and the obvious inclusions which hold between the elements of JI (e.g., $\langle \binom{\text{id}}{\leftrightarrow} \rangle \subseteq \text{Aut}(D; E)$). The groups in (3) are precisely those elements of JI which preserve $R^{(4)}$, (4) those which preserve $R^{(3)}$, and (5) those which preserve $R^{(5)}$. \square

Lemma 68. *The ideals containing $\text{Aut}(D; <)$ are the following:*

- (1) *the trivial ideal JI (ijk);*
- (2) $\text{dcl}\{\text{Aut}(D; <)\}$ (j);
- (3) $\text{dcl}\{\text{Aut}(D; <), \langle \binom{\text{id}}{\leftrightarrow} \rangle, \langle \binom{-}{\leftrightarrow} \rangle\}$ (bfj);
- (4) $\text{dcl}\{\text{Aut}(D; <), \langle \binom{\text{id}}{\circ} \rangle, \langle \binom{\text{sw}}{\circ} \rangle\}$ (aej);
- (5) $\text{dcl}\{\text{Aut}(D; <), \langle \binom{\text{id}}{\leftrightarrow} \rangle, \langle \binom{-}{\leftrightarrow} \rangle, \langle \binom{\text{id}}{\circ} \rangle, \langle \binom{\text{sw}}{\circ} \rangle\}$ ($abefj$).

Proof. This follows from Cameron's classification [Cam76] of the reducts of $\text{Aut}(D; <)$ and the obvious inclusions which hold between the elements of JI (e.g., $\langle \binom{-}{\text{id}} \rangle \subseteq \text{Aut}(D; <)$). The groups in (3) are precisely those elements of JI which preserve Betw , (4) those which preserve Cycl , and (5) those which preserve Sep . \square

Lemma 69. *The ideals containing $\text{Aut}(D; T)$ are the following:*

- (1) *the trivial ideal JI ;*
- (2) $\text{dcl}\{\text{Aut}(D; T)\}$ (k);
- (3) $\text{dcl}\{\text{Aut}(D; T), \binom{-}{\text{id}}, \binom{\text{id}}{\leftrightarrow}\}$ (ack);

- (4) $\text{dcl}\{\text{Aut}(D; T), \binom{\text{sw}}{\text{id}}, \binom{\text{id}}{\circ}\} \text{ (bdk)}$;
- (5) $\text{dcl}\{\text{Aut}(D; T), \binom{-}{\text{id}}, \binom{\text{id}}{\leftrightarrow}, \binom{\text{sw}}{\text{id}}, \binom{\text{id}}{\circ}\} \text{ (abcdk)}$.

Proof. This follows from Bennett's classification [Ben97] of the reducts of $\text{Aut}(D; T)$ and the obvious inclusions which hold between the elements of JI (e.g., $\langle \binom{-}{\text{id}} \rangle \subseteq \text{Aut}(D; T)$). The groups in (3) are precisely those elements of JI which preserve Betw_T , (4) those which preserve Cycl_T , and (5) those which preserve Sep_T . \square

6.2. Ideals containing $\langle \binom{l}{\text{id}} \rangle$ or $\langle \binom{u}{\text{id}} \rangle$. Recall the names of the elements of JI defined in Figures 1 and 2.

Lemma 70. *Let \mathcal{I} be an ideal of JI which contains $\langle \binom{l}{\text{id}} \rangle$ or $\langle \binom{u}{\text{id}} \rangle$. Then one of the following holds:*

- (1) $\mathcal{I} = \text{dcl}\{\langle \binom{l}{\text{id}} \rangle\} \text{ (g)}$;
- (2) $\mathcal{I} = \text{dcl}\{\langle \binom{u}{\text{id}} \rangle\} \text{ (h)}$;
- (3) $\mathcal{I} = \text{dcl}\{\langle \binom{\text{sw}}{\text{id}} \rangle, \langle \binom{l}{\text{id}} \rangle, \langle \binom{u}{\text{id}} \rangle\} \text{ (dgh)}$;
- (4) $\mathcal{I} = \text{dcl}\{\langle \binom{\text{id}}{\leftrightarrow} \rangle, \langle \binom{\text{sw}}{\text{id}} \rangle, \langle \binom{-}{\text{id}} \rangle, \langle \binom{l}{\text{id}} \rangle, \langle \binom{u}{\text{id}} \rangle\} \text{ (adegh)}$;
- (5) $\mathcal{I} = \text{dcl}\{\langle \binom{\text{id}}{\circ} \rangle, \langle \binom{\text{sw}}{\text{id}} \rangle, \langle \binom{l}{\text{id}} \rangle, \langle \binom{u}{\text{id}} \rangle\} \text{ (bdfgh)}$;
- (6) $\mathcal{I} = \text{dcl}\{\langle \binom{\text{id}}{\leftrightarrow} \rangle, \langle \binom{\text{id}}{\circ} \rangle, \langle \binom{\text{sw}}{\text{id}} \rangle, \langle \binom{-}{\text{id}} \rangle, \langle \binom{l}{\text{id}} \rangle, \langle \binom{u}{\text{id}} \rangle\} \text{ (abdefgh)}$.
- (7) \mathcal{I} contains $\text{Aut}(D; <)$.

Proof. We first show that $\langle \binom{l}{\text{id}}, \binom{u}{\text{id}} \rangle$ contains $\binom{\text{sw}}{\text{id}}$. It is clear that the group contains $\binom{-}{\text{id}}$. Let π be the irrational which defines both $\binom{l}{\text{id}}$ and $\binom{u}{\text{id}}$, and assume that $\binom{l}{\text{id}}$ and $\binom{u}{\text{id}}$ send the interval $(-\infty, \pi)$ onto itself. Then $\binom{-}{\text{id}} \circ \binom{l}{\text{id}} \circ \binom{u}{\text{id}}$ switches the graph relation between the intervals $(-\infty, \pi)$ and (π, ∞) , and keeps it otherwise. From this we see that $\binom{\text{sw}}{\text{id}}$ is contained in $\langle \binom{l}{\text{id}}, \binom{u}{\text{id}} \rangle$.

If $\mathcal{I} \subseteq \text{OP}$, then this implies that (1), (2), (3), or (7) holds. Otherwise, Propositions 12 and 29 imply that \mathcal{I} contains some $G \in \text{JI} \setminus \text{JI}^0$. From the obvious inclusions, it follows that \mathcal{I} contains either $\langle \binom{\text{id}}{\leftrightarrow} \rangle$, $\langle \binom{-}{\text{id}} \rangle$, $\langle \binom{\text{id}}{\circ} \rangle$ or $\langle \binom{\text{sw}}{\text{id}} \rangle$.

Note that \mathcal{I} contains $\langle \binom{\text{id}}{\leftrightarrow} \rangle$ if and only if it contains $\langle \binom{-}{\text{id}} \rangle$, since $\langle \binom{l}{\text{id}} \rangle$ and $\langle \binom{u}{\text{id}} \rangle$ both contain $\binom{-}{\text{id}}$. Moreover, if \mathcal{I} contains those functions, then it contains both $\langle \binom{l}{\text{id}} \rangle$ and $\langle \binom{u}{\text{id}} \rangle$. To see this, suppose it contains $\langle \binom{l}{\text{id}} \rangle$, and let π be the irrational defining $\binom{l}{\text{id}}$. Assuming that $\binom{l}{\text{id}}$ and $\binom{\text{id}}{\leftrightarrow}$ send the interval $(-\infty, \pi)$ onto itself, we then have $\binom{\text{id}}{\leftrightarrow} \circ \binom{l}{\text{id}} \circ \binom{\text{id}}{\leftrightarrow}$ behaves precisely like $\binom{u}{\text{id}}$.

If \mathcal{I} contains $\langle \binom{\text{id}}{\circ} \rangle$ or $\langle \binom{\text{sw}}{\text{id}} \rangle$, then it contains both $\langle \binom{l}{\text{id}} \rangle$ and $\langle \binom{u}{\text{id}} \rangle$: assuming that $\binom{\text{id}}{\circ}$ sends the interval $(-\infty, \pi)$ onto itself, we have that $\binom{\text{id}}{\circ} \circ \binom{l}{\text{id}} \circ \binom{\text{id}}{\circ}$ behaves like $\binom{u}{\text{id}}$; we obtain the same if we use $\binom{\text{sw}}{\text{id}}$ instead of $\binom{\text{id}}{\circ}$. Hence, in this situation \mathcal{I} also contains $\langle \binom{\text{sw}}{\text{id}} \rangle$, by our observation of the first paragraph. It follows that \mathcal{I} contains $\langle \binom{\text{id}}{\circ} \rangle$ if and only if it contains $\langle \binom{\text{sw}}{\text{id}} \rangle$, and the lemma is proven. \square

6.3. The remaining ideals. Finally we consider those ideals of JI which do not contain $\langle \binom{l}{\text{id}} \rangle$, $\langle \binom{u}{\text{id}} \rangle$, $\text{Aut}(D; <)$, $\text{Aut}(D; E)$, or $\text{Aut}(D; T)$; in other words, those ideals which are subsets of $\{\langle \binom{-}{\text{id}} \rangle, \langle \binom{\text{id}}{\leftrightarrow} \rangle, \langle \binom{-}{\text{id}} \rangle, \langle \binom{\text{sw}}{\text{id}} \rangle, \langle \binom{\text{id}}{\circ} \rangle, \langle \binom{\text{sw}}{\text{id}} \rangle\}$. Since they are numerous, we do not list them, but state the only restriction that holds for such subsets.

Lemma 71. *Let \mathcal{I} be an ideal of JI . Then:*

- \mathcal{I} contains none, exactly one, or all of $\left\{\binom{-}{\text{id}}, \binom{\text{id}}{\leftrightarrow}, \binom{-}{\leftrightarrow}\right\}$;
- \mathcal{I} contains none, exactly one, or all of $\left\{\binom{\text{sw}}{\text{id}}, \binom{\text{id}}{\circ}, \binom{\text{sw}}{\circ}\right\}$.

Proof. This is an easy exercise of composing functions, and we do not give the proof. \square

6.4. The final reduct count. Lemmas 67, 68, 69, 70, and 71 give us $4+4+4+6+(5 \times 5 - 1) = 42$ possible non-empty proper ideals. It remains to show that each of those sets is in fact an ideal. To this end, we list for every possible ideal \mathcal{I} a set of relations which is invariant under the group defined by \mathcal{I} (i.e., the group $\bigvee \mathcal{I}$). The relations show that all those groups are distinct. We need to define one relation which we have not encountered so far.

For a permutation σ of $\{1, 2, 3, 4\}$, write S_4^σ for the 4-ary relation

$$\{(a_1, a_2, a_3, a_4) \mid S_4(a_{\sigma(1)}, a_{\sigma(2)}, a_{\sigma(3)}, a_{\sigma(4)})\}.$$

Write D_4 for the dihedral group on $1, 2, 3, 4$. Set

$$S^D := \bigcup_{\sigma \in D_4} S_4^\sigma.$$

Figure 16 shows which ideals preserve which relations (presence of a cross in the table stands for “preserves”, and the absence for “violates”; the names of the elements of JI are defined in Figures 1 and 2). Checking the table can be automated and is left to the reader. We remark that the groups in OP correspond precisely to the rows in which the order relation $<$ is preserved.

6.5. The lattice inclusions. We finally describe how we have verified the edges in the Hasse diagram of \mathcal{L} in Figure 3. It is straightforward to verify that if there is an ascending edge from vertex u to vertex v in the diagram, then the group corresponding to u is contained in the group corresponding to v : we have labelled the vertices by the maximal elements of ideals of JI , and from those maximal elements one can calculate the ideals by adding $\{a, b\}$ when there is i among the maximal elements, $\{g, h, d\}$ when there is j , $\{c\}$ when there is g or when there is h , and $\{f, e\}$ when there is k . The containments between elements of JI we use here have been verified previously.

Next, we have to verify that whenever there is no edge between vertices u and v in the graph then either there is an ascending path in the diagram from one vertex to the other (and hence the edge is not displayed since it is in the transitive closure of the drawn edges of the Hasse diagram), or indeed the group corresponding to v does not contain the group corresponding to u . For this task we have used Figure 16; note that for a given u we only have to do the check for the v that are *maximal* with the property above, since then also all groups contained in the group corresponding to v will not contain the group corresponding to u as well (this reduces the work considerably).

We finally would like to comment on the visible symmetry of the lattice: besides the lattice automorphism that switches g and h and fixes all other elements of the lattice, there is also a lattice automorphism that acts as the permutation $(ik)(ae)(bf)(j)(g)(h)(c)(d)$ on JI . We have not found a concise argument for the existence of this automorphism without explicitly describing \mathcal{L} .

	E	$R^{(3)}$	$R^{(4)}$	$R^{(5)}$	$<$	Betw	Cycl	Sep	T	Betw $_T$	Cycl $_T$	Sep $_T$	R_3^l	R_3^u	S^D
a	x	x	x	x		x		x		x		x			x
b	x	x	x	x			x	x			x	x			x
c			x	x	x	x	x	x		x		x	x	x	x
d		x		x	x	x	x	x			x	x			x
e			x	x		x		x	x	x	x	x			x
f		x		x			x	x	x	x	x	x			x
g					x	x	x	x					x		x
h					x	x	x	x						x	x
i	x	x	x	x											
j					x	x	x	x							
k									x	x	x	x			
ab	x	x	x	x				x				x			x
ad		x		x		x		x				x			x
af		x		x				x		x		x			x
bc			x	x			x	x				x			x
be			x	x				x			x	x			x
cd				x	x	x	x	x				x			x
cf				x			x	x		x		x			x
de				x		x		x			x	x			x
ef				x				x	x	x	x	x			x
ace			x	x		x		x		x		x			x
bdf		x		x			x	x			x	x			x
abce			x	x				x				x			x
acde				x		x		x				x			x
acef				x				x		x		x			x
abdf		x		x				x				x			x
bcdf				x			x	x				x			x
bdef				x				x			x	x			x
abcdef				x				x				x			x
dgh					x	x	x	x							x
adegh						x		x							x
bdfgh							x	x							x
abdefgh								x							x
cei			x	x											
dfi		x		x											
cdefi				x											
aej						x		x							
bfj							x	x							
abefj								x							
ack										x		x			
bdk											x	x			
abcdk												x			

FIGURE 16. Preservation table. An x in an entry indicates that the relation of the column is preserved by the group G indicated by the row. Moreover, each group G equals the set of all permutations that preserve the relations that are marked by **x** in bold font.

REFERENCES

- [Ada79] Douglas Adams. *A hitchhiker's guide to the galaxy*. Pan Books, 1979.
- [AH78] Fred G. Abramson and Leo Harrington. Models without indiscernibles. *Journal of Symbolic Logic*, 43(3):572–600, 1978.
- [Ben97] James H. Bennett. *The reducts of some infinite homogeneous graphs and tournaments*. PhD thesis, Rutgers university, 1997.
- [BP] Manuel Bodirsky and Michael Pinsker. Schaefer's theorem for graphs. *Journal of the ACM*. To appear. A conference version appeared in the Proceedings of STOC 2011, pages 655–664.
- [BP11] Manuel Bodirsky and Michael Pinsker. Reducts of Ramsey structures. *AMS Contemporary Mathematics, vol. 558 (Model Theoretic Methods in Finite Combinatorics)*, pages 489–519, 2011.
- [BP14] Manuel Bodirsky and Michael Pinsker. Minimal functions on the random graph. *Israel Journal of Mathematics*, 200(1):251–296, 2014.
- [BPT13] Manuel Bodirsky, Michael Pinsker, and Todor Tsankov. Decidability of definability. *Journal of Symbolic Logic*, 78(4):1036–1054, 2013. A conference version appeared in the Proceedings of LICS 2011, pages 321–328.
- [Cam76] Peter J. Cameron. Transitivity of permutation groups on unordered sets. *Mathematische Zeitschrift*, 148:127–139, 1976.
- [Cam90] Peter J. Cameron. *Oligomorphic permutation groups*. Cambridge University Press, Cambridge, 1990.
- [Hod97] Wilfrid Hodges. *A shorter model theory*. Cambridge University Press, Cambridge, 1997.
- [JZ08] Markus Junker and Martin Ziegler. The 116 reducts of $(\mathbb{Q}, <, a)$. *Journal of Symbolic Logic*, 74(3):861–884, 2008.
- [LP14] Julie Linman and Michael Pinsker. Permutations on the random permutation. Preprint arXiv:1405.4297, 2014.
- [Mac11] Dugald Macpherson. A survey of homogeneous structures. *Discrete Mathematics*, 311(15):1599–1634, 2011.
- [NR83] Jaroslav Nešetřil and Vojtěch Rödl. Ramsey classes of set systems. *Journal of Combinatorial Theory, Series A*, 34(2):183–201, 1983.
- [NR89] Jaroslav Nešetřil and Vojtěch Rödl. The partite construction and Ramsey set systems. *Discrete Mathematics*, 75(1-3):327–334, 1989.
- [PPP⁺14] Péter Pál Pach, Michael Pinsker, Gabriella Pluhár, András Pongrácz, and Csaba Szabó. Reducts of the random partial order. *Advances in Mathematics*, 267:94–120, 2014.
- [Tho91] Simon Thomas. Reducts of the random graph. *Journal of Symbolic Logic*, 56(1):176–181, 1991.
- [Tho96] Simon Thomas. Reducts of random hypergraphs. *Annals of Pure and Applied Logic*, 80(2):165–193, 1996.
- [Tsa14] Todor Tsankov. Automorphism groups and their actions. Thèse présentée en vue de l'obtention de l'Habilitation à Diriger des Recherches, Université Paris Diderot, 2014. <http://webusers.imj-prg.fr/~todor.tsankov/papers/hdr.pdf>.

INSTITUT FÜR ALGEBRA, TU DRESDEN, 01062 DRESDEN, GERMANY

E-mail address: Manuel.Bodirsky@tu-dresden.de

URL: <http://www.math.tu-dresden.de/~bodirsky/>

INSTITUT FÜR COMPUTERSPRACHEN, THEORY AND LOGIC GROUP, TECHNISCHE UNIVERSITÄT WIEN, FAVORITENSTRASSE 9/E1852, A-1040 WIEN, AUSTRIA

E-mail address: marula@gmx.at

URL: <http://dmg.tuwien.ac.at/pinsker/>

LABORATOIRE D'INFORMATIQUE (LIX), CNRS UMR 7161, ÉCOLE POLYTECHNIQUE, 91128 PALAISEAU, FRANCE

E-mail address: pongeee@cs.elte.hu

URL: <http://www.lix.polytechnique.fr/~andras.pongracz/>