

World Maritime University

# The Maritime Commons: Digital Repository of the World Maritime University

---

World Maritime University Dissertations

Dissertations

---

1990

## Safe stowage and securing of cargo evaluation of training needs

Adolphe David Abiassi  
*World Maritime University*

Follow this and additional works at: [https://commons.wmu.se/all\\_dissertations](https://commons.wmu.se/all_dissertations)

---

### Recommended Citation

Abiassi, Adolphe David, "Safe stowage and securing of cargo evaluation of training needs" (1990). *World Maritime University Dissertations*. 1322.

[https://commons.wmu.se/all\\_dissertations/1322](https://commons.wmu.se/all_dissertations/1322)

This Dissertation is brought to you courtesy of Maritime Commons. Open Access items may be downloaded for non-commercial, fair use academic purposes. No items may be hosted on another server or web site without express written permission from the World Maritime University. For more information, please contact [library@wmu.se](mailto:library@wmu.se).

**WMU LIBRARY**

WORLD MARITIME UNIVERSITY  
MALMO, SWEDEN

SAFE STOWAGE AND SECURING OF CARGO  
EVALUATION OF TRAINING NEEDS

by

Adolphe David Abiassi

Benin

A paper submitted to the Faculty of the World Maritime University  
in partial satisfaction of the requirements for the award of a

MASTER OF SCIENCE DEGREE  
in  
MARITIME EDUCATION AND TRAINING (NAUTICAL)

The contents of this paper reflect my personal views and are not  
necessarily endorsed by the UNIVERSITY.

Signature:

Date:



Supervised and assessed by:

Co-assessed by:



Capt. S.J. Cross  
Lecturer  
World Maritime University

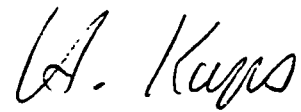

Prof. Capt. H. Kaps  
Deputy Head  
Dept. of Nautical Studies  
Hochschule Bremen  
F R G

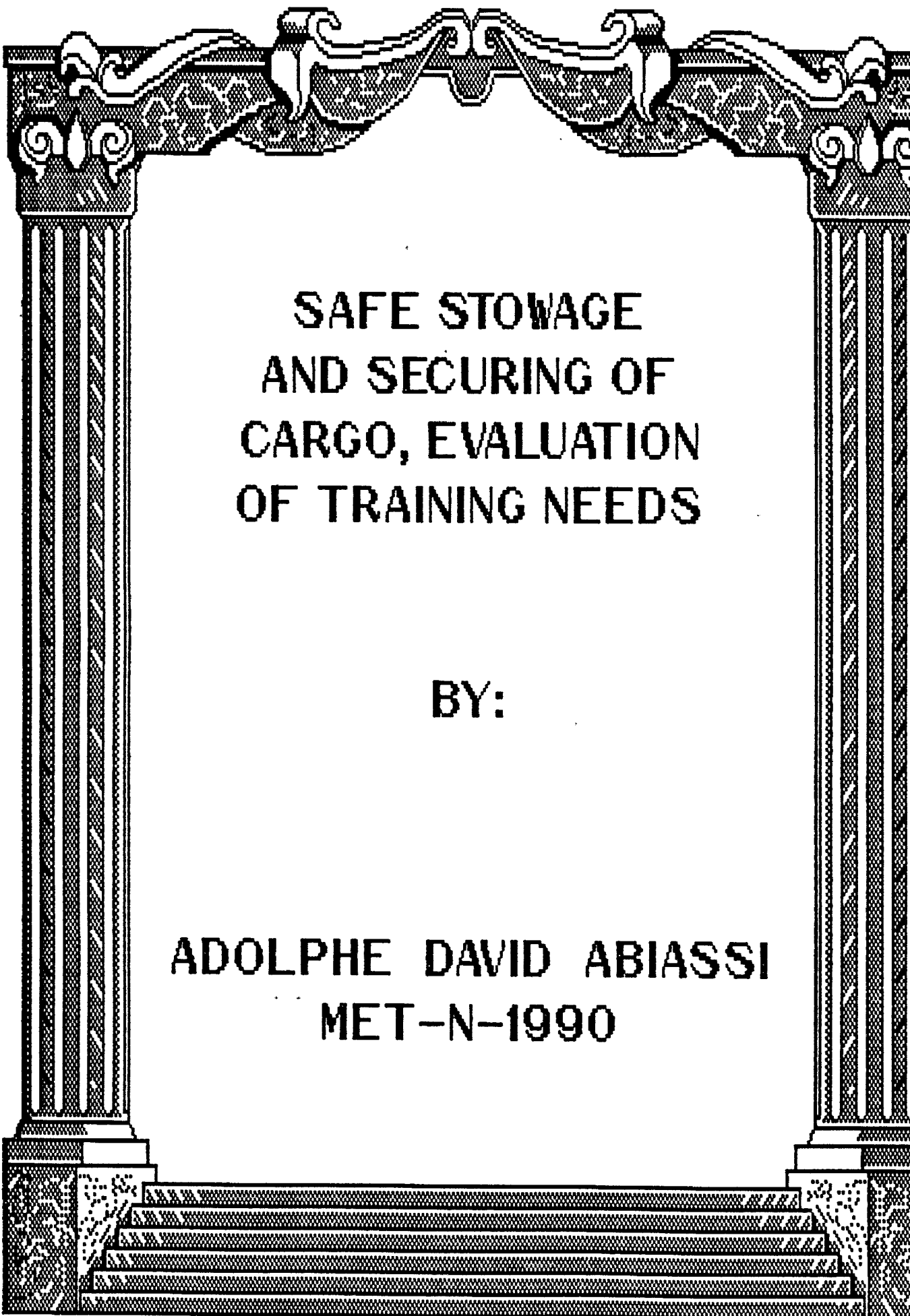

**SAFE STOWAGE  
AND SECURING OF  
CARGO, EVALUATION  
OF TRAINING NEEDS**

**BY:**

**ADOLPHE DAVID ABIASSI  
MET-N-1990**

**DEDICATIONS .**

**" AU NOM DE DIEU**

**LE CLEMENT**

**LE MISERICORDIEUX "**

In memory of the Reverend Pastor S.B.J. OSHOFFA.

In memory of my mother in law JACQUELINE MANSILLA de SOUZA who died while I was pursuing this two-year course.

For AGNES, DUENNA, DALHIA, and ALDA, who give me the moral support and cooperation during the two year study.



## **ACKNOWLEDGEMENTS .**

The Safe Stowage and Securing of Cargo will always be a topic to which many experts will put more and more attention, because of the several and serious accidents which have happened in the last two decades.

This paper represents my modest contribution to the topic.

The achievement of this project owes much to the contributions from many individuals and organizations to whom and to which I would like to express my gratitude.

Firstly I would like to thank Professor GUNTHER ZADE who advised me to choose this topic.

Much of this project would have been impossible without the regular assessment of Capt. STEPHEN CROSS and Professor Capt. HERMANN KAPS, who have accepted to direct this paper, and have employed all their efforts to bring it to this final stage. Therefore, I thank them for their sincere assistance.

My special thanks goes to my Course Professor, Professor JEF.H. MULDER for his advice and encouragement.

I am indebted to the United Nations Development Program (via the IMO), for its generosity in sponsoring me for this two-year study at the World Maritime University.

My sincere and profound gratitude goes to the Ministry of Transport and Equipment of BENIN and also to the Board of Governors of the "Academie des Sciences et Techniques de la Mer" for nominating me for this course.

I wish to thank all the resident and visiting Professors, Faculty Staff, and particularly the English Language Staff and the Librarian, Richard Poisson for their assistance during the two-year study.

I am grateful to Capt. WERNHULT and Capt. ERIKSSON who supplied me with the necessary documents and information for the accident analysis.

In my family, I owe a special debt of gratitude to my parents Mr. ABIASSI GODWIIL and Mrs. ABIASSI MARIE YOUTH who have always provided me with the necessary moral assistance and encouragement.

My thanks, also goes to my brothers and sisters, my family in law, and particularly to AMEN and his wife MAI whose help in one way or another contributed to the successful completion of my two-year study.

Finally, I wish I could have mentioned by name all my friends to whom I also owe gratitude.

A.A.D.

Nov. 90

Malmo.

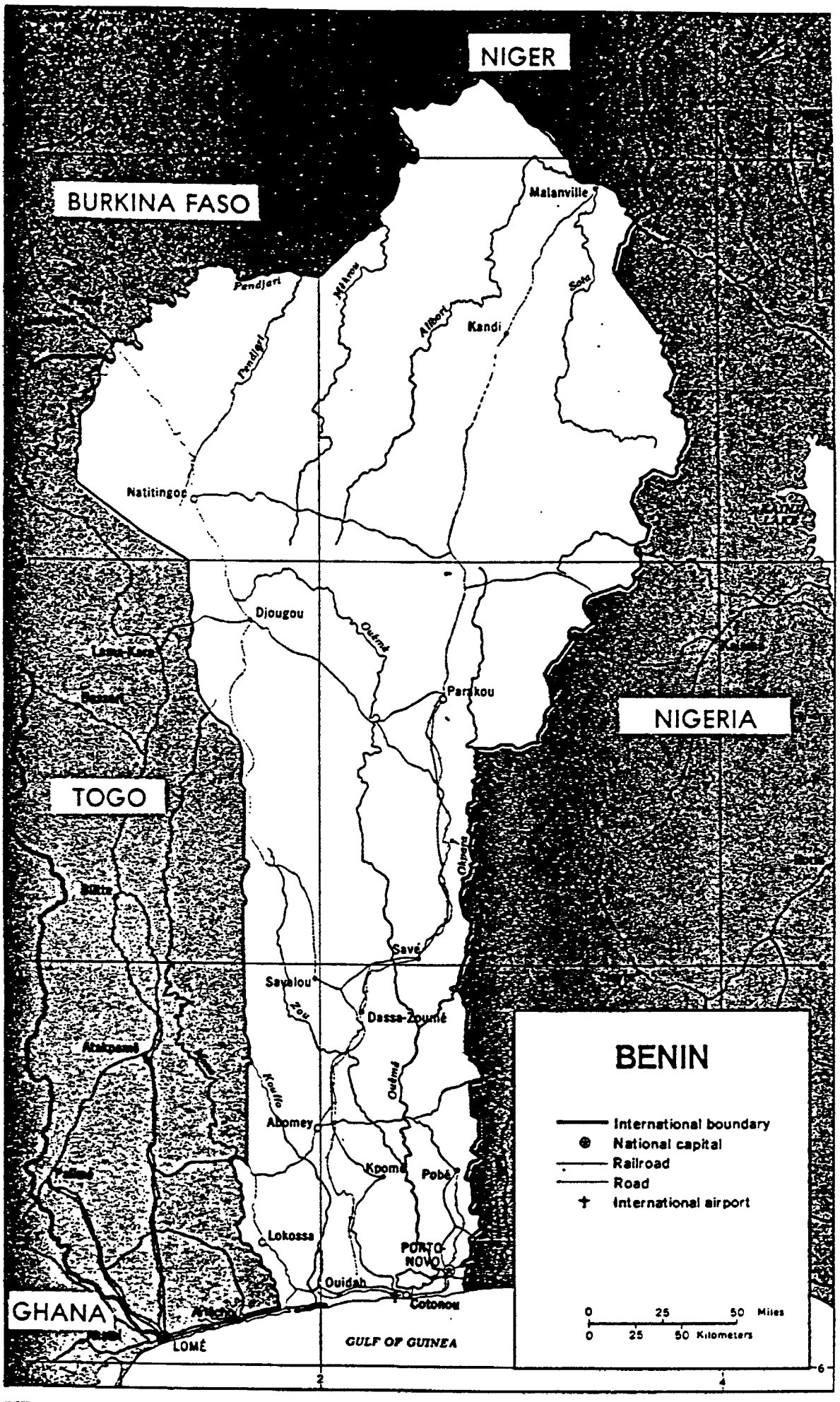

NIGER

BURKINA FASO

NIGERIA

TOGO

**BENIN**

- International boundary
- ⊙ National capital
- Railroad
- Road
- ✈ International airport

0 25 50 Miles  
0 25 50 Kilometers

GHANA

LOMÉ

GULF OF GUINEA

PORTO-NOVO

Ouidah

Cotonou

Abomey

Dassa-Zoumé

Savalou

Savé

Parakou

Diougou

Natitingou

Matanville

Kandi

Soto

Alibori

Mali

Pendjari

Pendjari

Bènin

Atakpame

Kpalimé

Atakora

# **TABLE OF CONTENTS**

**DEDICATION .**

**ACKNOWLEDGEMENTS .**

**ABSTRACT .**

**INTRODUCTION .**

**PART ONE :**

**IMPORTANCE OF SAFE STOWAGE AND  
SECURING OF CARGO IN THE  
MODERN TRANSPORTATION SYSTEMS .**

	<b>Pages.</b>
<b>CHAPTER 1: TRANSPORTATION SYSTEMS.</b>	<b>1 -18</b>
<b>1.1.VESSEL DESIGNS AND OUTFITS.</b>	<b>1 - 9</b>
1.1.1. Conventional General Cargo Ships.	1 - 2
1.1.2. Modern Multi Purpose Ships.	2 - 3
1.1.3. Container Ships.	3 - 4
1.1.4. Ro/Ro Ships.	4 - 5
1.1.5. Barge Carriers.	5 - 7
1.1.6. Special Heavy Lift Ships.	7 - 8
1.1.7. Bulk Carriers.	8 - 9
<b>1.2.CARGO CATEGORIES.</b>	<b>9 -18</b>
1.2.1. Conventional Stowed Cargoes.	9 -13
1.2.2. ISO-Containers.	13 -15
1.2.3. Rolling Cargoes.	15 -17
1.2.4. Heavy Lift Units.	17 -18
<b>CHAPTER 2: ANALYSIS OF ACCIDENTS. :</b>	<b>19 -40</b>

2.1.CASE STUDIES OF ACCIDENTS DUE TO CARGO SHIFTING.	20 -37
2.1.1. The Finneagle Case.	20 -29
2.1.2. Case of Vinca-Gorthon.	29 -37
2.2.SOME MORE EXAMPLES OF CASUALTIES IN THE LAST 30 YEARS.	37 -40

**PART TWO :**

**ANALYSIS OF PRACTICAL SOLUTIONS  
AND THE WAY OF PLANNING AND  
IMPLEMENTING THE SAFE STOWAGE  
AND SECURING OF CARGO.**

CHAPTER 3: ENVIRONMENT AS PARAMETER FOR FOR SHIP'S OPERATION.	43 -57
3.1.DESCRPTION OF THE ENVIRONMENT.	44 -53
3.1.1. Seaway	45 -48
3.1.2. Wind	48 -52
3.1,3. Dynamic Behavior in Wind	52 -53
3.2.WEATHER ROUTEING ELEMENTS.	53 -57
3.2.1. The Objectives of Ship-Routeing	53 -54
3.2.2. The Method used for Weather Routeing	54 -55
3.2.3. Classification of Routeing	55 -56
3.2.4. Regions of Weather Routeing	57
CHAPTER 4: THE TECHNICAL ASPECTS OF SAFE STOWAGE AND SECURING OF CARGO.	58 -94
4.1.CRITERIA FOR ESTIMATING THE RISK OF CARGO SHIFTING.	59 -61
4.1.1. The Dimensional and Physical Properties of the Cargo	59
4.1.2. The Location of Stowage on Board	60

4.1.3. The Suitability of the Ship for Particular Cargo	60
4.1.4. The Suitability of the Securing Arrangement for Particular Cargo	60 -61
4.1.5. The Expected Weather and Sea Condition	61
4.1.6. The Expected Ship Behavior During The Intended Voyage	61
4.2. REDUCTION OF RISKS THROUGH PROPER STOWAGE.	61 -66
4.2.1. General elements to be considered by the Master	61 -62
4.2.2. Cargo Information	62
4.2.3. Cargo Distribution	62 -64
4.2.4. The Use of Friction force for Cargo Securing	64 -66
4.3. SECURING OF CARGO UNDER SPECIAL CONDITIONS.	66 -78
4.3.1. Standardized Securing System	67 -73
4.3.2. Semi-Standardized Stowage and Securing	73 -75
4.3.3. Non-Standardized Stowage and Securing	75 -78
4.4. CARGO SECURING CALCULATIONS.	78 -93
4.4.1. External Forces to the Cargo	80 -82
4.4.2. Securing Forces to the Cargo	82 -85
4.4.3. Safety Factor (SF)	85 -87
4.4.4. Balance of Forces and Moments	87 -91
4.4.5. Worked Example	91 -93
 CHAPTER 5: THE PRACTICAL USE OF SECURING MATERIALS.	 95-115
5.1. THE DIFFERENT KINDS OF SECURING EQUIPMENT.	95-105
5.1.1. Fixed Securing Equipment	95 -97
5.1.2. Loose Securing Equipment	97-105
5.2. SOME PRACTICAL ADVICE REGARDING SECURING OF CARGO.	105-115
5.2.1. Sources of Failure in Lashing Arrangements	105-108
5.2.2. Some Practical Advice and	

Recommandations	108-112
5.2.3. Avoiding of Cargo Shifting by good Shiphandling in heavy Weather	113-115

**PART THREE :**

**EVALUATION OF THEORETICAL  
AND PRACTICAL TRAINING .**

<b>CHAPTER 6: BASIC TRAINING ON SAFE STOWAGE AND SECURING OF CARGO AT THE LOWER LEVEL.</b>	<b>118-127</b>
6.1. PEOPLE INVOLVED IN THIS TRAINING AND ITS OBJECTIVES.	119-120
6.1.1. The Objectives of this Training	119
6.1.2. The Involved Personnel	119-120
6.2. THE MAIN ASPECTS OF THIS TRAINING.	120-124
6.2.1. Standardization of Securing System	120-121
6.2.2. The Need of Skilled Dock and Industry Workers for Securing Tasks	121-122
6.2.3. The Particular Characteristics of Shore-based Workers Training	122-123
6.2.4. The Particular Characteristics of Ship's Crew Training	123-124
6.3. DETAILS OF THE TRAINING PROGRAM FOR CARGO SECURING PERSONNEL.	124-127
6.3.1. The Detailed Teaching Syllabus	124-125
6.3.2. Guidelines and Organization of the Training	125-127
<b>CHAPTER 7: HIGH LEVEL TRAINING FOR SHIP'S OFFICERS AND SURVEYORS.</b>	<b>127-139</b>
7.1. THEORETICAL ASPECTS OF THE TRAINING.	128-133
7.1.1. General Overviews	128
7.1.2. The Model of the Training Syllabus	129
7.1.3. Some Comments on The Different	

Points of The Syllabus	129-134
7.1.4. Some Remarks about The Teaching Methods	134
7.2.PRACTICAL ASPECTS OF THE TRAINING.	135-138
7.2.1. General Overviews	135-136
7.2.2. Some case studies developed as Example by Bremen Training Center	136-138
7.3.SOME BENEFITS OF THE TRAINING AND SOME RECOMMENDATIONS	138-139
 <b>CHAPTER 8: REFRESHER AND UPDATING COURSE.</b>	 <b>139-146</b>
8.1.THE NEED FOR A REFRESHER AND UPDATING COURSE.	140-141
8.2.DETAILED TEACHING SYLLABUS	141-144
8.2.1. Theoretical Aspects of this Training	141-142
8.2.2. Practical Aspects of this Training	142-144
8.3.SOME IMPORTANT POINTS OF THE TRAINING.	144-146
8.3.1. The Organization of the Training	144-145
8.3.2. Some Recommendations Regarding the Training	145-146
 <b>CONCLUSION.</b>	 <b>147-152</b>
 <b>APPENDICES .</b>	
 <b>BIBLIOGRAPHY .</b>	



## **ABSTRACT.**

Cargo has always been a problem for the safety of the ship, either in bad or good weather.

Any movement of the cargo e.g. lateral (sliding) or rotational (tipping) on board, can cause damage to the ship and sometimes can be a hazard to human life at sea.

In modern cargo handling, with large, relatively heavy cargo units, individually lashed on board, the shifting of cargo can be caused by one or several of the following factors:

- the cargo is not sufficiently secured inside the cargo unit;
- the cargo unit is not sufficiently secured to the ship;
- ⊗ the cargo unit is not designed for sea transportation;
- ⊗ the ship is unsuitable for the cargo unit;
- the cargo is inappropriately packed; etc.

A cargo unit which is not sufficiently secured to the ship, can cause shifting of cargo in larger or smaller areas of the ship. Especially serious consequences can arise if the shifting of cargo occurs in an area where dangerous cargo is stowed.

In recent years there have been a number of accidents involving shifting of semi-trailers and general cargo on Ro/Ro ships, especially in short-sea traffic. These accidents have highlighted the problem of securing of cargo on board ships, and this has led to research work within this field.

Many research works have been concentrated on particular means of cargo transportation such as:

- stowage and securing of containers, which is generally regulated by the classification societies;

- societies;
- road trailers suitable for sea transportation (MariTerm 1983);
  - securing of road trailers on board Ro/Ro ships (MariTerm AB 1984);
  - securing of goods on semi-trailers (Swedish Transport research Commission 1986);
  - the securing of cargo with special reference to Roll-on/Roll-off ships (by University of Lancaster UK); etc.

Some experts in the field have tried to bring the treatment of this problem into a broader perspective. The objective of this research paper is to analyse some of these works, and to emphasize this broader perspective which can give a more general and standardized approach to the problem.

To achieve this, the paper has been divided into three parts:

1.- Part one:

"Importance of Safe Stowage and Securing of Cargo in the Modern Transportation Systems", which is subdivided into two chapters.

It first points at the dependance of vessel designs and outfits with the categories of cargo to be carried.

The second chapter which deals with the analysis of accidents gives some case studies of serious casualties due to cargo shifting, and lists additionally some examples of accidents in the last 30 years.

2.- Part two:

"Analysis of Practical Solutions and the Way of Planning and Implementing the Safe Stowage and Securing of Cargo", consists of three chapters. It is the technical part of the paper which points out a general

approach to the problem in a scientific manner, by giving a simple solution, very easy to implement. It also describes some practical use of cargo securing systems and suggests some recommendations to the users of the securing devices.

3.- Part three:

"Evaluation of Theoretical and Practical Training", which is subdivided into three chapters. The first chapter shows the need of training in general and proposes a basic training for the people at the lower level who dealt directly with the problem of securing of cargo. The second chapter gives a proposal of a training model at a higher level in maritime academies for ship's officers and surveyors. Finally, the third one is the suggestion of a refresher and updating course at various levels for seafarers, shipping company personnel and surveyors.

## INTRODUCTION .

During the last 30 years, the world of shipping industry was shaken by many kinds of accidents directly or indirectly caused by shifting of cargo on board ship.

The most serious casualties of this series of accidents started in mid-1960s with the loss of:

- Heraklion (1966);
- Badger State (1969);
- Captain Niko (1973);
- Buskozdroj (1985);
- L.Nikoleos (1987);
- Lloyd Bermuda (1988) ect.

In the first six months of 1987, according to the statement of Mr. Hodd "We saw the loss of three container ships, the Oriental Faith, the Hanjin Incheon and the Tuxpan; six bulk carriers, the Testarossa, the Cathay Seatrade, the Hyundai New World, the Quatsino Sound, the Star Carrier and the Cumberland. Finally, of course we lost one passenger Ro/Ro, the Herald of Free Enterprise, a human tragedy which has appaled the maritime industry". Despite the great success of the modern maritime transport technologies, a very essential problem still remains: damage and losses of cargo and sometimes loss of human life.

By maritime transport accidents, the world trade suffers a yearly loss of billions of dollars.

This lost money cannot be invested in new projects and badly hinders economic progress.

Some 60% of the average cargo underwriters' nett premium income will be paid out as claims for damage to cargo insured in 1993. Of this, 24% of the nett premium income, relates to damage to cargo where the adequacy of stowage of cargo has been tested during transportation methods to the point where it failed.

The statistics of the main causes of loss published by CIGNA Philadelphia, estimate that handling and stowage of cargo

Philadelphia, estimate that handling and stowage of cargo constitute the most important reasons for damage and loss of cargo in the shipping industry.

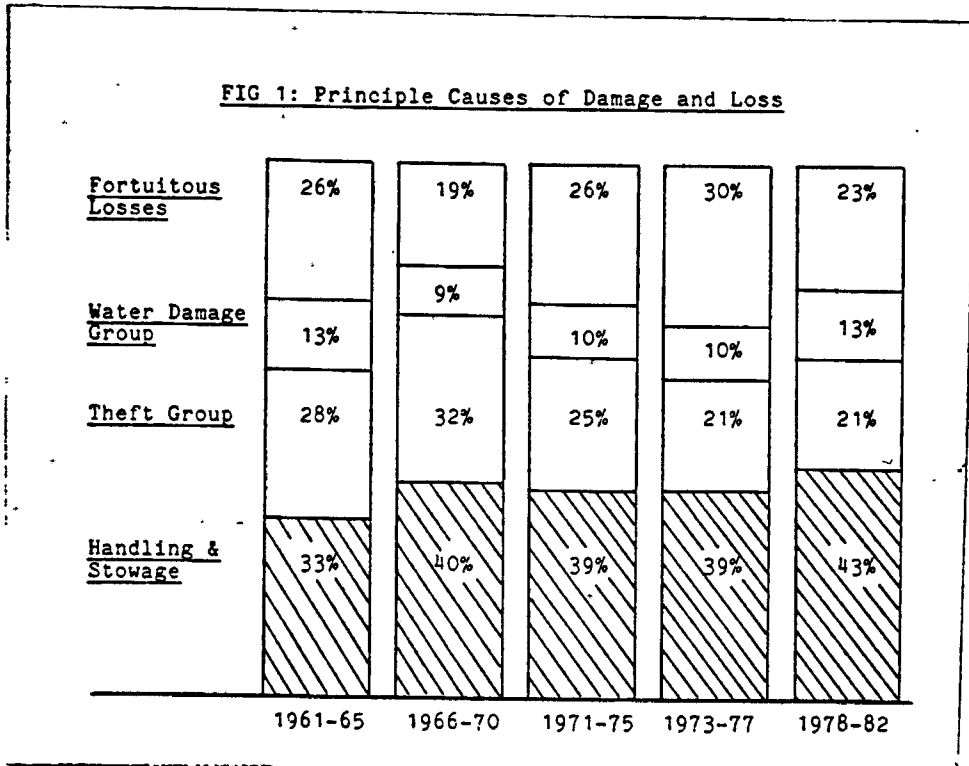

As it can be seen in this figure and by these data, handling and stowage of cargo as a cause has been grown since 1965 to 1982. Indeed, the shifting of cargo on board ships requires more and more attention. Cargo shifting together with operational causes, constitutes a larger part of the serious casualties than all other casualties: 16% as compared to 12%. The international organizations: ILO (International Labour Organization) and IMO (International Maritime Organization) have lately recognized the problems with combined transport of goods in cargo units in international traffic where sea transport is included.

Especially within IMO, the main purpose of which is to promote safety at sea and to protect the marine environment, they intend to present a common international safety system. The work within the area of cargo safety has until now

resulted in a "Code on Safe Practice for the Stowage and Securing of Cargo".

Proper stowage and securing of cargo is of the utmost importance for safety of life at sea.

Due to ship motions at sea e.g. in bad weather, it is necessary to secure the cargo in one way or the other on board ship to prevent casualties. In what manner the cargo is secured, depends first of all on the ship and the type of cargo to be shipped; and secondly on the lashing forces used to encounter the external forces arising from wind and ship's motions which are acting on the cargo.

To solve this problem (in order to assure the safety of life at sea), an international agreement is needed with a simple and scientific approach which would take into account the calculations of the different forces in lashing and those which are acting on the cargo (due to wind and ship's motions). This would release the isolated approaches of classification societies and national requirements which are actually the most popular in the shipping. In addition to that, good skilled personnel would be necessary to achieve this goal; therefore the introduction of the training in the field of cargo securing becomes a need.

The intention of this project is to study the Safe Stowage and Securing of Cargo from various publications and sources, and to propose a scheme of training for proper cargo securing. The project will consist of three parts:

- Part one which contains two chapters will show the importance of safe stowage and securing of cargo in the modern transportation systems;

- Part two which consists of three chapters will make the analysis of practical solutions and describe the way of planning and implementing the safe stowage and securing of cargo.

- Finally, Part three with also three chapters will give a training proposal to achieve a safe stowage and securing of cargo.

## PART ONE.

# IMPORTANCE OF SAFE STOWAGE AND SECURING OF CARGO IN THE MODERN TRANSPORTATION SYSTEMS.

## CHAPTER 1. TRANSPORTATION SYSTEMS.

A wide variety of goods are internationally traded, and many transportation systems are used to carry them. Those goods can be carried by air (air transportation system), by sea (maritime transportation system), by rail (railway transportation system), by road (trailer and lorries transportation system) etc. In this context the maritime transportation system which is the one that will be dealt with, has been through many changes regarding the outfits of the transportation means (ships) in the last 30 years. These tremendous changes in the ship's design and outfits justify the modernization of the maritime transportation system. In this chapter I will try briefly to describe the different categories of ships which are used today in the modern transportation system, the various categories of cargoes they carry and finally show their main features related to stowage securing and safety of cargo.

### 1.1. VESSEL DESIGNS AND OUTFITS.

#### 1.1.1. Conventional General Cargo Ships.

Conventional general cargo ships are multi-deck vessels and their holds are divided horizontally by one or two tween decks. Usually powerful cargo handling gear is available on this type of ship. Due to the problem of collecting cargoes at different ports and of loading/unloading time, the deadweight is limited to about 12000-25000 t. For economical reasons, relatively high speed is required.

t. For economical reasons, relatively high speed is required. According to their outfit, conventional general cargo ships have some main features relating to stowage, securing, safety of cargo, which are: [12]

- mostly two or three low tweendecks, moderate height of lower holds, which allows low or moderate height of stowage blocks and easier securing of cargo;
- hatches of moderate width which provides deep under deck stowage and favors stowage from side to side;
- moderate to high values of L/B-ratio thus good seakeeping can be expected;
- good to moderate equipment with lashing eyes on weather deck, cross bulkheads, tweendeck and lower hold sides, tank bottom. Conventional general cargo ships are no longer constructed nowadays, but are considered to stay in service for about another 10 years.

#### 1.1.2. Modern Multi Purpose Ships.

Multipurpose ships which came in use in the last 20 years, are ships capable of carrying different types of cargoes which require different methods of handling. In this context, the multipurpose ship derived from the conventional general cargo ship after the introduction of container shipping is meant. In this type of ship, only one tweendeck is left with a very large height. They are designed with large and wide hatches in which cargoes are only lowered instead of being stowed. Some of them are built with one wide hatch per hold and others with two parallel hatches per hold. They are more suitable for unit cargo than loose cargo. The large width of the hatches allows them to use the weather deck hatchcovers more for the cargo. Even with full deck cargoes their stability is adequate because of the large initial metacentric height, which would make them stiff in their seakeeping. Regarding stowage, securing, and safety of



cargo the main features are: [12]

- generally one tweendeck of considerable height and high;  
lower holds, thus resulting in high stowage blocks with;  
considerable stacking pressure and sometimes difficult cargo securing;
- one wide or two parallel hatches per hold, thus providing good spot loading capability but less means of horizontal separation; vertical separation of stowage blocks is preferred resulting in additional securing problems;
- moderate to low values of L/B-ratio and often high values of B/D-ratio resulting in high GM-minimum requirements, which lead to poor seakeeping;
- sometimes specially equipped with container loading and securing system according to accepted standards (classification society) in holds, and on deck and hatch covers, equipment which is not suitable for the lashing of other cargoes.

The Semi-container ship is actually a late variation of the conventional general cargo ship, but may be added to the multipurpose ships in this context. They used to carry general cargo in the holds and containers on deck, or had special container holds (with cell guide) in the square bottom section of the ship.

### 1.1.3. Container Ships.

A Container Ship is the vessel now most commonly used to transport containers across the seas. They are big in size and have a free hatchcover deck space for cargo. Their most obvious distinguishing feature is the arrangement of their holds which are in the most cases fitted with double hatches and ballast capacity on the bottom and on the side. They are single deckers and their holds and hatchways occupy

the same area, the dimensions of which are determined by the container sizes. Most container ships are capable of carrying a significant number of containers on deck. In a few cases container ships with certain sizes are fitted with anti-rolling fins or anti-roll tanks which can give them acceptable roll amplitudes. Their service speed is very high compared to the conventional general cargo ship (20-30 knots). Their main features related to stowage, securing, and safety of cargo are: [12]

- no tweendeck, no under deck stowage, but cell guides for containers in holds;
- stacking and securing system on deck and hatchcovers, according to accepted standard;
- ample tank capacity for ballasting, trimming and increasing poor stability, but seldom for reducing high stability;
- moderate to good seakeeping, anti-rolling fins or active roll tanks in a few cases.

Container ships lately seem to follow the trend for a high value of the B/D-ratio with all its consequences (high GM required, poor seakeeping qualities).

#### 1.1.4.- Ro/Ro Ships.

Ro/Ro ships originally evolved from the ferry ships. They are designed in various sizes and types. Until the early 1970s pure Ro/Ro ships were believed to be suitable only for short sea trades and many of them were operated as passenger/vehicle ferries. Most were therefore fairly small. Larger Ro/Ro vessels have recently been found suitable for a number of longer routes notably to the Middle East and West Africa, where inadequate port facilities have been less of a handicap to Ro/Ro ships than to conventional general cargo ships. Not only can they load and discharge quickly, but the angled ramps with which many of them are equipped make them independent of quayside handling equipment. They are ships which use their deck capacity for rolling cargo and the

containers can be stacked in different levels of the ship. These containers which are brought on board by fork lifts are stacked not in longitudinal direction, but across ship. This can be a problem for the structural strength of the container. Regarding the stowage, there is no more contact between the units which are standing alone. Each of them is single unit and they need to be secured, because there is no interconnection between them. Ro/RO ships are wasting stowage area or stowage capacity, because there is a lot of spaces which are unused under the vehicles, beside and above. These spaces must to be paid for. In order to compete with other types of cargo carriage, there must be an advantage in the Ro/Ro ship; this advantage is the time dispatch, which means loading and immediate sailing. For this reason, securing devices which are used take very little time to be fitted. The main features relating to stowage, securing and safety of cargo are: [12]

- cargo movement on wheels using stern ramp (sometimes bow ramp additionally);
- stowage of vehicles without any interlocking;
- stowage separation scheme in longitudinal lanes;
- appropriate securing equipment available
- very short time allowances for loading and securing of cargo;
- in many cases high stability by design and construction, in order to meet disadvantageous distributions of cargo, which results in poor seakeeping;
- anti-roll devices in some cases;
- the inevitable spaces between cargo units support the so-called "domino-effect" if the securing of one unit fails.

Ro/Ro ships are used in several variations as: - pure Ro/Ro vessels, Container Ro/Ro vessels (CONRO), Car-Passenger-ship (CAPA) and Passenger-Car ship (PACA).

### 1.1.5.- Barge Carriers.

There are now in service a number of vessels designed to carry standard barges, each with a capacity of several hundred tonnes. These barges, which are loaded with cargo often in a wide variety, are towed to the ship and lifted or in some cases, floated on board. This concept was designed to eliminate the need for specialized port equipment and to avoid transshipment with its consequent extra costs. In one design the LASH (lighter aboard ship) concept-loaded rectangular barges are towed to the anchored carrier which loads them over the stern by means of a massive mobile gantry. Once on board they are transported forward by the gantry and lowered into their designed stowage position. An alternative arrangement -the "SEABEE" concept - is also established in service. Here the rectangular lighters, which are larger than those used by LASH ships, are raised clear of the water by a hydraulic elevator situated at the carrier's stern. They are then transported on rails forward into the hull by way of a stern opening. The weather deck area may be used for containers loaded and discharged by crane in the usual manner.

A third smaller barge -carrying system known as BACAT (barge aboard catamaran) has also been introduced. In this arrangement, a catamaran carrier is used to carry barges between its hulls and on deck.

According to their outfits, the main features regarding stowage, securing and safety of cargo are: [12]

- stowage and securing of cargo inside the barges is not under supervision of ship's officers;
- barges have sufficient volume to permit dangerous shifting of cargo inside when not all the space has been filled, e.g. with cargoes of large specific weight;
- securing of cargo in barges cannot be checked and refitted during the voyage of the ship due

to inaccessibility;

- poor equipment of barges with respect to lashing points;
- some types of barge carriers have to be operated with large GM-values, which leads to poor seakeeping and consequently to considerable stress in cargo securing devices.

#### 1.1.6.-Special Heavy Lift Ships.

Heavy lift ships are designed to lift and carry exceptionally heavy loads such as railway locomotives. These are loaded and discharged by means of a heavy lift derrick fixed to the deck of the ship. It is only since the late 1960s that small vessels have been introduced exclusively for carrying heavy lift cargoes. There are now some ships in the 1000-7000 tdw-range with speeds up to 14 knots, either new buildings or conversions, available for charter to carry indivisible loads weighing up to 1000 tonnes apiece. Such loads include nuclear power plants, petrochemical and oil refining plants, electrical generating components etc. They are either hoisted on board, from quay or barge, by ship's derricks (capacity of lifting up to 700-1000 tonnes), or rolled aboard on heavy lift trailers. The ship's dimensions are selected to cater for loads which may be over 50m long and up to 14m wide. Arrangements vary between bridge forward, aft or on side, with derricks forward or on the side. All have as open a deck as possible. A large flush hatch is located in the weather deck so that all but the largest loads can be carried under cover. A similar deck is located in the tween-deck if fitted. Cargo may either be stowed on the inner bottom, if its height is below 6m so that, the weather deck covers can be closed; or if it is too high, either on the weather deck or not sometimes on the tween-deck covers with the weather deck covers unused. Their main features related to stowage, securing and safety of cargo are: [12]

- cargo is carried on deck or in the hold (without any tween-deck);
- positioning and securing of cargo are generally accomplished by skilled personnel, under supervision of experienced ship staff and shipping experts;
- the strength of cargo securing is often precalculated according to expected ship behaviour;
- ships have generally been designed with a large initial stability which in many shipments is of little use, but results only in poor seakeeping;
- ships are generally not operated at schedule. This allows adequate ship handling (course and speed) to avoid unacceptable stresses in cargo securing.

#### 1.1.7.- Bulk Carriers.

Bulk carriers are single deck ships designed to carry homogeneous unpacked dry cargoes such as grain, iron ore and coal. Their development has occurred since the 1950s with the need for ships to transport large quantities of bulk cargo. In many ore carriers longitudinal bulkheads are fitted in every hold in the way of the hatch side coamings, to enclose just enough volume to accommodate a full ore cargo. This results in a deeper stowage which is more readily discharged by grabs. The wing spaces, out board of the longitudinal bulkheads are used for water ballast. These wing spaces can be designed with small hold volume (for less dense bulk commodities) or with large volume.

Bulk carriers are sometime used for the shipment of goods which are generally carried on multipurpose ships. Their main features regarding stowage, securing and safety of cargo are:

[12]

- non tween-decks, thus deep holds resulting in

- high stacking pressure to any cargo;
- large initial stability with any heavy cargo resulting in poor seakeeping (except when in alternative loading mode);
- generally no lashing eyes in the holds.

## 1.2.CARGO CATEGORIES.

### 1.2.1.- Conventionally Stowed Cargoes

Many general goods which are sometimes manufactured or semi-finished, commonly constitute liner cargoes and they are traditionally transported in break bulk form. These cargoes represent the large variety of goods packages and units which have been shipped over the seas for centuries. Their only common feature is that they have to be handled, stowed and secured with individual techniques. They can be subdivided into - single units and stowage blocks of cargo.

#### 1.2.1.1. Single Units.

When cargo is not suitable, because of its size, shape, weight or other reason, it may sometimes be made up into a unit load suitable for handling with mechanical equipment. Cargoes which are handled like unit loads are called single units such as:

- ✓ heavy lift cases ✓
- ✓ ISO-containers (in other than container specific stowage);
- ✓ vehicles;
- ✓ unpacked heavy cargo units.

#### 1.2.1.2. Stowage Blocks of Cargo.

\* Cases, crates, fibre boxes.

Cases and crates are usually made of timber which may be plywood or thin low grade material. Heavier cases may be built up of planks with strengthening pieces internally and

externally. Cartons are usually made of single or multi wall fibre board. Cases and cartons hold a very wide range of commodities depending on the requirement of the particular cargo. Light cases and cartons should be stowed one upon the other so that each one below bears the full weight of the one above and particularly in the case of cartons of e.g. canned goods, no overhangs should occur which might distort the cartons and rupture the content. This allows also to provide the rigidity of the block regarding the securing of cargo.

#### 1.2.1.3. Bags made of jute, paper or plastic material.

The material from which bags are made will depend on a number of factor such as: the commodity to be shipped, its physical composition and its properties. The principal materials include:

- + paper (single or multi-ply) which may be sewn or glued;

- + plastic (which may be air tight);

- + jute, etc (traditional material and the type most likely to have repeated use, e.g. second hand bags). The most common filled weight of bags today is 50 kilograms. This allows rapid and easy calculation of weights taken on board into containers or to make up sling loads etc. Plastic bags have the tendency to slide. Therefore a good stowage of these bags is required in order to avoid an eventual cargo shifting when the ship encounters heavy weather.

#### \* Drums.

Drums may be made out of metal, fibre board or rigid plastic. They are used in carriage of liquid cargoes, powder, granules and chemicals. Some of them are used for packing of dangerous commodities. Drums stowed on their side should not have other cargo stowed on top. Drums holding liquids should always be at the bottom of the stow with the bungs or lid upmost.

When more than one tier of metal drums are be stowed, particularly into the container, where vibrations may be



experienced during transport, it is prudent to lay soft dunnage (wood, hard board, chipboard) between each tier.

\* Pallets with any of the above packages.

Pallets are small rectangular platforms usually made of wood, to which items of general cargo i.a. drums, cartons etc can be secured to form a unit that is easily handled by fork lift truck. They are made in various ways, strengths and sizes, depending on the goods to be supported and the use to which the pallet will be put. An attempt has been made by the International Standards Organization (ISO) to standardize pallet sizes. Some recommended sizes are:

- 1000x800mm(40"x32")
- 1200x800mm(48"x32")
- 1200x1000mm(48"x40").

A laden pallet handled by a fork lift truck constitutes a heavy combination and care must be taken to avoid exceeding point loading strengths allotted by classification societies to most vessels. Another type of pallet base or skid is the fibre board or plastic slip-sheet or slip-pad.

\* Long iron profile bars or bundles of these bars.

Long iron profile bars are usually no more than 12 metres in length, but some are considerably longer, calling for vessels with large, unobstructed hatchways. Athwartship stowage of long iron profile bars, is dangerous in that they are more likely to shift and hopper tanks can be punctured. Furthermore, dunnage sustaining such heavy weights will compress during passage, perhaps causing cargo to touch ship sides and care should be taken during loading to avoid this subsequently occurring. Consequently, longitudinal stowage is desired, with considerable quantities of dunnage (1tonne of dunnage for every 100 tonnes of cargo).

\* Pipes or bundles of pipes.

Pipes of smaller diameter may be shipped in bundles,

but larger steel pipes require more sophisticated attention, once again, large quantities of dunnage. The longest sections of seaborne steel pipes are around 20 metres, although many shipped are no longer than the standard 12 metres. Their weight varying accordingly up to 5 tonnes apiece for each of the longer sections. Even so, given broken stowage pipe are usually a cubic cargo. The carrying vessel becomes full before using all her available cargo deadweight tonnage. The exception to this is with specialized piping for certain uses e.g.: for the oil industry. Consequently, for the lighter uncoated pipes deck carriage may be required to make a cargo profitable to the carrier.

\* Metal sheets, bundles of sheets.

Alternatively, steel sheets may be carried in packs protected by bitumenised paper and steel sheeting, thereafter strapped on wooden skids, which serve the dual purpose of aiding air-flow when stowed and easing cargo-handling especially by fork-lift truck, without damaging the cargo.

\* Steel coils.

Most of the time, steel sheeting is manufactured, traded and carried in form of coils, these are frequently heavy, perhaps up to 20/25 tonnes each. Here it is vital that the coil edges remain undamaged throughout handling and carriage and that the coil point weight is spread evenly across a vessel's tanktops at the bottom of her holds by adequate use of dunnage. Many modern bulkcarriers and multi-purpose vessels have tanktops specially strengthened for these and similar heavy weighted cargo. Usually coils will be given a bottom stow in a vessel's holds, in rows athwartship (from port to starboard) and in line from fore to aft. Thick dunnage across tanktops will spread weights. It is desirable that only coils of similar size and weight be stowed together, but where mixed stowage is necessary smaller coils should be loaded last, atop the heavier units.

\* Wire rods.

They are produced principally through the process of drawing larger bars through dies, then rolled into coils, with four or five strapped together forming an unprotected, but unitized bundles. Unless carefully handled these straps are prone to shift together leaving the opposite side of the coil/bundle to splay open and to distort the rod. Such bundles are best stowed in a similar manner to coils, although not more than six tiers or so high.

\* Small metal bars.

Small section material is usually on passage for the manufacture of finished products such as: steel furniture, tools shelving etc. It is highly valuable and liable to damage from anything, therefore the handling and stowage have to be taken with care. It is commonly shipped in wrapped bundles and a top stowage position is recommended in order to prevent bending and permanent distortion of the product.

The above given subdivision and description may serve as a guide for identification of typical stowage and securing problems. The solutions for these problems can be recommended and displayed in a cargo securing manual with due regard to the ship type they are carried on.

1.2.2.- ISO-Containers.

The International Standards Organization has recommended series of external and internal dimensions for containers, together with gross maximum weights which the containers may achieve (complete with cargo). The most common sizes and weights are:

1.2.2.1. Sea Land Containers which may be 35ft long, as well as 40ft long. The 35ft-containers are 8ft 6.1/2in high, 8ft wide and with a gross rating 22,500kgs. The 40ft-containers which may be 8ft 6.1/2in high, 9ft 6.1/2in wide have a gross

rating of 27,000kgs.

1.2.2.2. ISO standards include 8ft and 8ft 6in high containers. Some operators are building containers 9ft and 9ft 6in high, which are increasingly being distributed throughout the system. Care must be taken when planning the ship load, particularly cellular ships.

1.2.2.3. Nowadays there is an increasing trend to build and rate 20ft containers in excess of ISO-recommendations. Many such containers are rated at 24 tonnes.

#### 1.2.2.4. Flats.

A flat is basically a floor of a container with container fittings at each corner, but no corner posts. Not suited to being lifted by conventional spreader, but easily handled by overheight frames, or frames with wire legs. Flats may have fork lift pockets and may be secured by the bottom corner castings.

#### 1.2.2.5. Sea Freighters.

They are similar to ISO flatracks and are particularly used in the Australian trades, with the following dimensions -length=4.39m 2.44m wide, 1.88m high gross weight 15.22 tonnes, with a tare of weight of 1.5 tonnes; this permits a payload of 13.72 tonnes.

Thus ISO-containers permit unitized stowage and securing on ships fitted with specific equipment. The corner fittings may be used in connection with stacking devices to prevent horizontal shifting, or with locking devices to prevent vertical lifting. The corner fittings may be used to connect lashing or coupling devices with limited lateral pull. The classification societies are dealing with the securing of ISO-containers. For this purpose they require ship specific pre-calculation of securing effort, provision of accepted equipment and plans for the correct attachment of securing

devices. Thus the necessary information for safe stowage and securing is already available on ships which are fully or partly designed for the transport of containers.

### 1.2.3.- Rolling Cargoes.

Rolling cargoes are considered to be fast shipping cargoes and are therefore mainly found on Ro/Ro ships. This specialized units can be divided into two distinct parts - that where the rolling units are themselves the cargo- and that in which the rolling units contain cargo.

#### 1.2.3.1. Vehicles representing themselves as cargo.

##### \* Cars, Busses, Trucks.

The carriage by sea of today's motor cars is a business which involves a lot of money. Many are exported over shortsea routes e.g. Spain to UK, in fairly small specialized pure car carriers (PCC), Ro/Ro type vessels capable of carrying about 500 units per trip. Most however, are moved across the oceans e.g. from Japan to Europe, in larger PCC's of up to 5,000 unit capacities on closely spaced deck of less than 2 metres clearance. When car demand slackens, the operators are forced to find less lucrative conventional bulk trades. Consequently, in an effort to diversify and to lessen total dependence on carriage of cars, manufacturers and shippers are today developing sales of high sided vehicles and trucks especially to the third world countries. These units are too tall and perhaps too heavy for the conventional PCC's. This leads to the introduction of the PCTC (pure car and truck carrier).

\* Rolling machines (railway engine and wagons, cranes, excavators).

In the deepsea market railway engines and wagons themselves form lucrative cargoes for those traders experienced in their shipment and for owners of ships able to transport them. Because of the considerable weight and size

of these units, it was one commonplace to carry them on deck using extensive dunnage. The introduction of twinhatch and openhatch ships, has however, opened up alternatives by which these bulky units can be lowered directly to their stowage positions and lashed/secured into place without too much interference or restriction of other goods. Unlike, the movement of railway units by train ferry, the seaborne transportation of wagons and engines tends to be over long distance from manufacturing areas to developing countries. The units tend to be large, a typical example, (Canadian wagons to East Africa) being:

length overall= 14m  
width overall = 2.5m  
height = 3.0m  
weight = 18 tonnes

Other wheeled vehicles transported by sea include bulldozers (12m x 3.6m x 4m with 16.96 tonnes), excavators (7.6m x 2.8m x 3.56m with 25.6 tonnes), busses (11.21m x 2.15m x 3.03m with 9.5 tonnes)

#### 1.2.3.2. Vehicles which carry the actual cargo.

##### \* Road trailers, trucks.

In its simplest form, heavy goods vehicles e.g. trucks towing containers and trailers, drive aboard ships equipped with suitable stern and/or bow ramp and decks, and then are secured before a short passage. It may be that some of the trailers are unloaded for stowage on board (e.g. pallets or containers lifted off and stacked); the trailers are then being moved ashore with their tractor unit. For deepsea Ro/Ro, usually the cargo is off-loaded on the quay from its truck and trailer unit and stowed conventionally for the sea passage; large fork lift trucks being utilized for this operation.

##### \* Roll trailers.

They are vehicles with their loads which are loaded on

board specialized ships such as Ro/Ro ships. For this purpose, deck height clearances must also be adequate, not only to allow the stowage of high-sided vehicles and their loads, but also, overheight vehicles in way of access ramps. Furthermore one must take into consideration vehicle "envelope" which is defined as the extra vertical area in excess of its normal height required by a vehicle as it negotiates, without fouling any obstruction above e.g. entrance, deckhead, trunking, etc.

Securing techniques suffer from a widespread lack of reliable securing points on the vehicles, which are needed for lashing them to the ship and furthermore from inadequacies in securing the goods within the road trailers. Road trailers are often loaded poorly with regard to the conditions in sea transportation.

Nevertheless, recommendations for securing do already exist and are widely used in practice. The relative uniformity of rolling cargoes permits some degrees of standardization of securing techniques. It may therefore be advisable to prepare ship specific information for safe transport of rolling cargo.

#### 1.2.4.- Heavy Lift Units.

Heavy indivisible loads may be defined as those weights, which, because of their mass and/or their shape cannot be handled by the normal gear available on board ship or on the quay alongside. The techniques for handling and transporting very heavy indivisible loads have changed and become more specialized with the growth of off-shore oil industry. For this market they are commonly divided into two categories: i.e. those, which are above 150 tonnes and those, which cannot be transported on the public highway. The base dimensions of the load also govern the number of axles which can be placed under it and hence the axle loading transmitted on to the ground. Many units were developed and built by shipyards to satisfy the need of transporting such heavy loads (see

paragraph 1.1. 6.). The stowage position of such units, must be selected which can best support the weight of the heavy lift. There may be also a requirement to have the heavy weight in such a position in the ship, that the acceleration forces generated by pitching and scending will not affect the loads or its securing. All lashings should utilize the appropriate and approved points on a load to give the support. Where necessary extra securing points will have to be welded to ship's frame. They require a thorough consultation on stowage and securing, which cannot easily be given by general recommendations. [12];[25];[26]



## CHAPTER 2: ANALYSIS OF ACCIDENTS.

The introduction of Container-ships and Ro/Ro-ships in the maritime transportation system brought revolution in the cargo handling methods. Over the last few years, the "Marine Underwriters" have been required to face the consequences of this revolution in the cargo handling. Not only has there been a change in handling; there has also been a major change in cause of loss and quantity of loss.

Vessels like Ro/Ro-ships have rear doors and large modern Ro/Ro-ships frequently have side loading doors in addition to the rear door. These present their own problems, because such doors have to be larger to allow large vehicles to enter, but of course they are a breach in the integrity of the hull. However well designed, they are a point of weakness in heavy weather and not only in heavy weather. : "HERAKLION" had her side loading door breached when a trailer broke loose in fine weather after course change, which causes a list to the ship. The conventional method of stowing cargo has been reconsidered and cargo on trailer or in vehicles has been driven on board. The trailers and the vehicles can be properly lashed for the voyage, but what happens inside the trailer or vehicles when the vessel encounters heavy weather? The scene changes as the Atlantic is crossed. The European underwriters report a number of casualties where vehicles and loaded trailers have sustained damage. Across the English Channel, 20 casualties involving 60 vehicles , trailers and their cargoes suffered loss or damage. In the Mediterranean 19 casualties involving 82 vehicles and loaded trailers were reported. In 60% of the events damage is directly attributed to shifting of cargo loaded on trucks or trailers, because of defective stowages or lack of lashings. Shifting of cargo occurs when elementary measures are not taken such as:

- cargo is not sufficiently secured in the cargo unit;
- the unit is not sufficiently secured to the

ship;

~~A~~ the cargo unit not designed for sea transportation

- cargo difficult to secure is stowed where large acceleration may occur and cargo is inappropriately packed

My intention in this chapter, is to study some cases of casualties due to cargo shifting and give some examples which occurred during the last 30 years.

## 2.1.CASE STUDIES OF ACCIDENTS DUE TO CARGO SHIFTING.

The purpose of these case studies, which will be described in this paragraph, is to point out how dangerous the cargo shifting in heavy weather can be and may lead to ship and cargo losses, and sometimes to human life loss when the securing of cargo is not properly done.

### 2.1.1.The Finneagle Case.

The Swedish Ro/Ro ship Finneagle owned by Skaerhamns Oljetransport AB and registered in Skaerhamns, was on a voyage from New-Orleans(USA) to Vallhamn(Sweden). On October 1, 1980 when the ship was North of Scotland, the bad weather caused a shifting of the cargo on second deck and a tank container containing trimethylphosphite shifted. The container was resecured but came loose again when the ship made some violent lurches. Once again, as the crew members were on the second deck to put more lashings on the tank container, a fire broke out followed some minutes later by a powerful explosion. The fire immediately increased in ferocity and the fire spread over the whole ship.

#### 2.1.1.1. The main particulars of Finneagle.

The Finneagle is a Ro/Ro ship built in 1979 as the last in a series of four. The ship's gross tonnage is 8,761 registered tons and net tonnage 4,623 tons. Her deadweight

is 14,497 tons on the summer freeboard mark. The ship's length overall is 183.14 meters and moulded breadth 24.0 meters. The ship's service speed is 17 knots. She is designed for the transport of containers, wheeled cargo, goods on pallets, heavy machines. Cargo is loaded on the tween deck by means of two flexible loading ramps in the stern. From the tween deck the cargo is taken up to the upper deck via a loading ramp. Cargo can be transferred by means of a hydraulic lift from the tween deck to the lower hold. The ship has superstructures both fore and aft, joined by an enclosed passage way on the port side. The enclosed aft superstructure mainly contains casings, stores and garage. The fore superstructure is open at the aft edge and is used as a garage.

#### 2.1.1.2. The loading.

The first port of loading was Vera Cruz and further loading took place in Houston, in Mobile and finally in New Orleans (the last port of call). In all 5,743 tons of cargo were taken on board. The cargo consisted mainly of unitized goods on platforms, stackmasters and in containers. There was also packaged timber, refrigerated trailers and a piece of machinery. All the cargo capacity was almost fully utilized, but not the deadweight. A part of the container cargoes were filled up with dangerous goods according to the IMDG code and they were listed in a chart drawn up by the captain. The trailers were new refrigerated trailers complete with cooling generators and their starting batteries.

#### 2.1.1.3. The cargo stowage for this voyage.

The cargo was mixed and distributed as follows:

- On upper deck.

Forward of frame 80 the ship was loaded with rolling cargo consisting of these new refrigerated trailers which were empty and some work machines. Between frames 60-80 some containers stowed up to three high, were loaded. On the

starboard side between frames 10-50(aft garage) packaged timber was stowed.

- On second deck.

The space forward of frame 89 was filled up with empty flats and containers. Packaged timber and roll trailers were stowed between frames 80-89; each trailer was loaded with two 40' containers and furthest out on the starboard side there were an empty reefer trailer and a crane arm. In the area, approximately frames 56-80, on the port side, containers, stack masters and flats were stowed in two long ship tiers, between frames 58-65 in three tiers, while empty reefer trailers were used to fill up the remaining place. Between frames 10-58 starboard of the engine casing there were flats and containers and on the port side of the engine casing there were various types of cargo: heavy machine goods on roll trailers, cargo on flats, large wooden boxes and packaged timber. The aft of frame 10 was filled up with empty refrigerated trailers and one crane.

- On the tank top.

The cargo was stowed in containers, stack masters or flats. In the area by the elevator there were moreover two empty reefer trailers.

#### 2.1.1.4. The ship's conditions at the beginning of the voyage.

\* The securing on the loaded cargo.

The loading ports called by ship are respectively: Vera Cruz Houston, Mobile and New Orleans.

Because of the loading and unloading sequence, however, certain container cargo on the tween deck had been loaded fore-and-aft without special securing devices. The units were set up on planks and fastened with chains. Among these was a tank container containing the inflammable liquid trimethylphosphite (IMDG goods, class 3.3.). The securing of cargo in each deck level was done as follows:

- Upper deck: the empty trailers forward were each

lashed with about 6 chains of 11 or 13mm, with tension levers. Most of the containers were secured by four sliding cones, the majority of which was equipped with loading pins. Some units were secured by three sliding cones only. In most cases there were twistlocks in all four corner castings between the top and lower units. The timber aft starboard of the engine casing was lashed with chain and tension levers.

- Second deck: the forward empty units were lashed with chains and the containers with sliding cones and twistlocks. The roll trailers between frames 80-89 were lashed to deck with chains. The containers were stowed in attachments on the trailers. The top and bottom containers were locked together with twistlocks. The units were secured by chains from the top container's lower corner castings to attachments in the deck. All empty reefer trailers were or appeared to have been lashed with 4-6 chains each. The containers which were placed in the tier furthest to the port side and the units aft of frame 61 were all secured by sliding cones, most of which were provided with locking pins. The units which remained in the second longship tier from the port side were placed on dunnage and lashed with chain diagonally in the fore and aft ends. The securing between the top and lower units in most cases consisted of four twistlocks. There were exceptions from this e.g. the flat which was stowed on top of stack master was only secured by two twistlocks. The cargo to the port of the engine casing was lashed with chain, wire and steel band. The cargo which was loaded on flats and stack masters was lashed on these with steel bands.

- The tank top: the tank top is not equipped with container securing arrangements. The cargo which almost exclusively consisted of containers and flats was secured in the larger part of the compartment by the units being stowed tight from side to side. In some parts the cargo was chocked up with square timber. Some units had been secured with several chains across the units along the long sides of

these. Most of the units on the tank top were placed on dunnage.

\* The ship's stability on departure.

According to the captain's statement " During the voyage the ship had a rolling period which reached about 25 seconds, indicating a metacentric height of between 0.4 and 0.5m."

In the inquiry commission's view, the ship had a satisfactory stability during the voyage.

Like most modern Ro/Ro ships, the Finneagle possesses such a hull line and other characteristics that the ship has a great tendency to heel and make violent movements in high sea, especially if the sea comes from astern or from the quarter. These characteristics make heavy demands on the securing of the cargo on board. Calculations as to the ships' stability on its departure from New-Orleans have not been preserved. On the other hand there are preliminary calculations of the ship's trim and stability, which point to a metacentric height coinciding with the minimum requirement of 15cm. The preliminary calculations show that the average draught was 7.32m, while the actual draught according to the sailing report was 7.80m This indicates that the ship was ballasted after the preliminary calculations of stability had been made. At the time of the accident the ship had a rough following sea which can result in a larger encounter period( $T_e$ ), a risk of Mathieu resonance( $T_e=T_o$  or  $T_e=T_o/2$ ) and finally in loss of stability including capsizing.

#### 2.1.1.5. The Voyage and the Weather conditions.

On board weather maps have been collected sent out by the Meteorological Office in Bracknell England, dated 28 September, GMT 00.00. The maps show "Surface" with high and low pressure areas entered, and combined sea and swell "analysis" and this for 24,48,72 hours prognoses. According to the forecast the wave height of over 8m was expected with an increasingly heaving sea in the area of N 57-00,W 021-30.

The ship left New Orleans after completing loading on 21 September 1980. During the voyage the securing of cargo was continually checked and slack chains tightened. During the night of 30 September Rockall(UK) was passed, wind and sea increased in strength. According to the master the weather was fine right up to the afternoon of 30 September, when the wind veered from South-west to West and increased in strength. Early the next morning(on 1st October), the master was awakened by the ship's rolling about 15degr to each side in the following sea. He estimated the wave height to 15-20 feet. Two hours later, he reduced successively the speed and the main engine's number of revolutions. A check in the cargo holds revealed that some platforms had shifted on the tween deck in the aft part. Measures were taken to remedy this situation. As the rolling increased all deck crew went down to the holds where they checked and improved lashings of the cargo. The wind increased in force reaching 10 to 12 the beaufort scale. The master continued the voyage as planned in a rough following sea with the height of about 40 feet. About mid-day the ship gave three powerful lurches and listed about 40degr. The master judged it would be imprudent to attempt to turn the because of a risk of cargo shifting. A check on the cargo revealed that two units, a platform and a stack master on the tween deck loaded with general cargo, had begun to slip. These loose units had broken off the fastenings on four other units, after which these also came adrift. These four units consisting of double-stacked platforms, stack masters and containers, broke away and shifted to starboard, against the empty refrigerated trailers there.

#### 2.1.1.6. The Shifting of Cargo.

Cargo shifting was observed in the following places:

- \* Upper deck.

Four tank containers stowed longitudinally two high between frames 65.5-70.5 in the outer tier on starboard side, had tipped over to the starboard side and were lying against

the bulwark. Two containers were stowed athwartship two high between frames 68-69. The bottom container had collapsed completely due to fire damage and the top container had fallen down on deck towards the starboard side.

\* Second deck.

Among the empty units forward of frame 80, some minor shiftings were noted. Between frames 80-89 the packaged timber had shifted towards the starboard side and rested against two of the roll trailers, each loaded with 40'-containers. These in turn had tipped over towards the empty reefer trailer which rested against the crane arm and the ship's side. Within the area of frames 59-75, the cargo on stack master and the flat stowed there, had collapsed towards starboard. Stack master(31) and container (33) had tipped over towards starboard, while container (28) had tipped over towards port side. Tank container (UTCU111 003-4) has shifted towards starboard and had been perforated against reefer trailer(8):see picture.

Starboard of the engine casing aft of frame 59 there was a considerable amount of palletized bagged cargo on flats. The flats remained in their twistlocks, while a number of pallets had collapsed both towards starboard and port. Port of the engine casing, most of the cargo had shifted towards starboard.

\* The tank top.

The shifting on the tank top can be summarized as follows: units 41 and 42 were, at the beginning of the voyage, stowed along the port bulkhead. Reefer trailer 47 stood on the elevator, but had possibly, in connection with the explosion on the tank top, been thrown towards port.

\* Forces in chain lashings.

On the ship's port side on second deck there were a number of containers, stack masters and flats stowed longitudinally two high which were not locked in fixed container fittings, but were lashed against deck with chains. At the beginning of the voyage all these units are said to



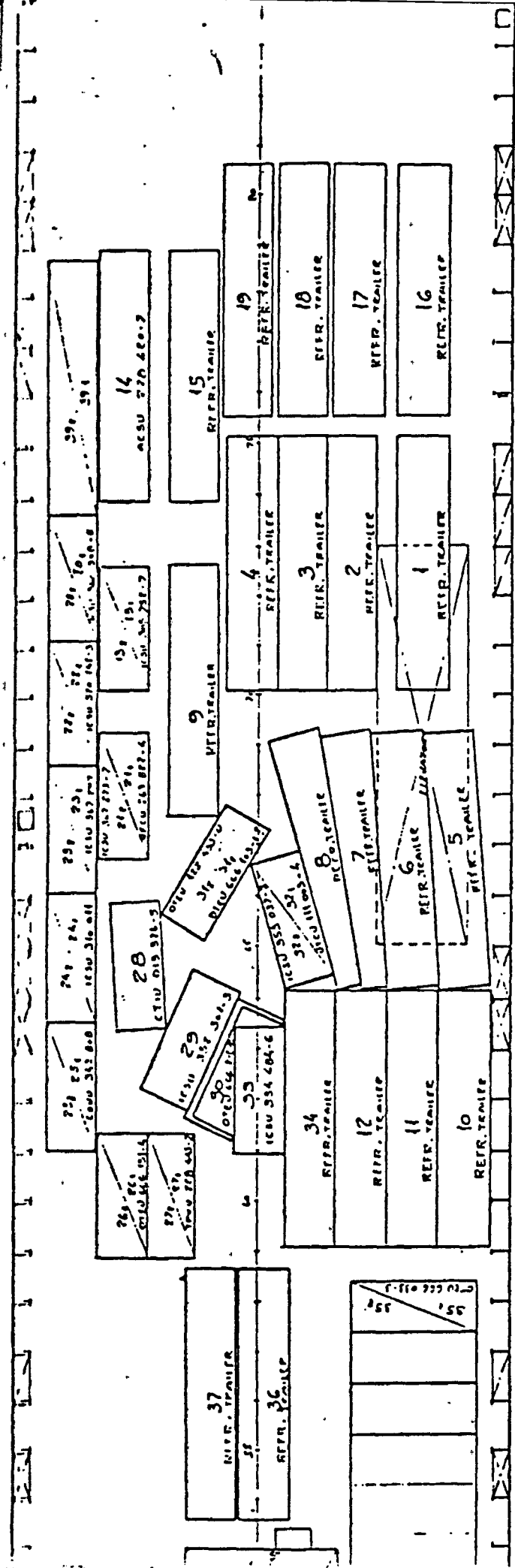

2ND DECK

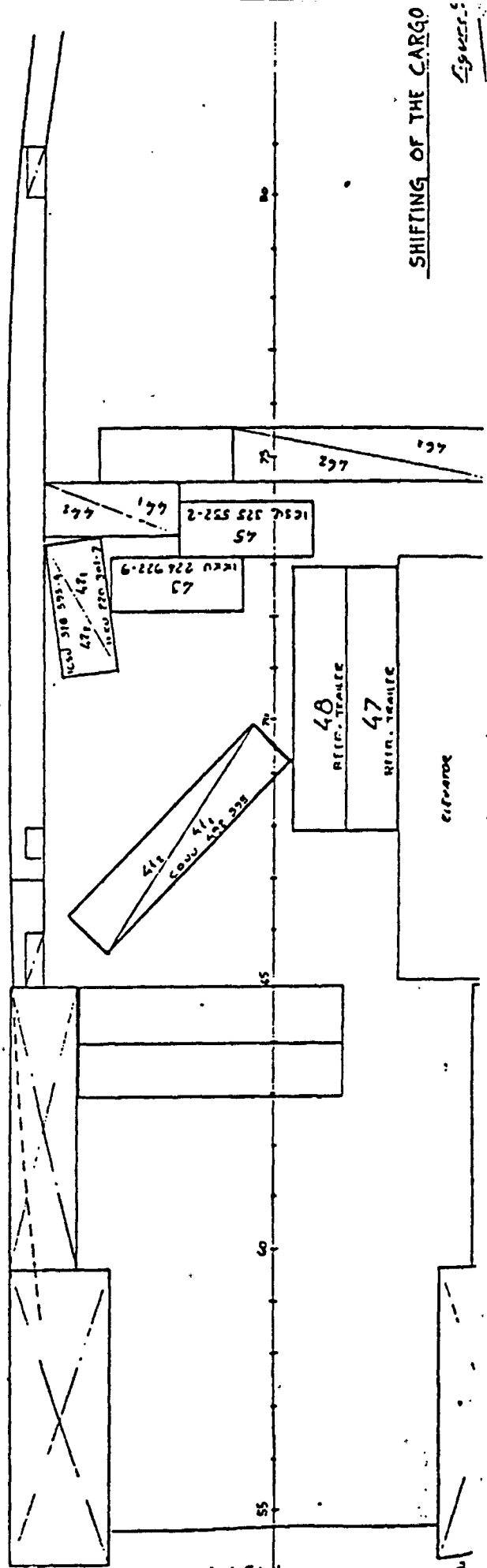

Cargo shifting on second and tank top at frames 55

SHIFTING OF THE CARGO  
Spones

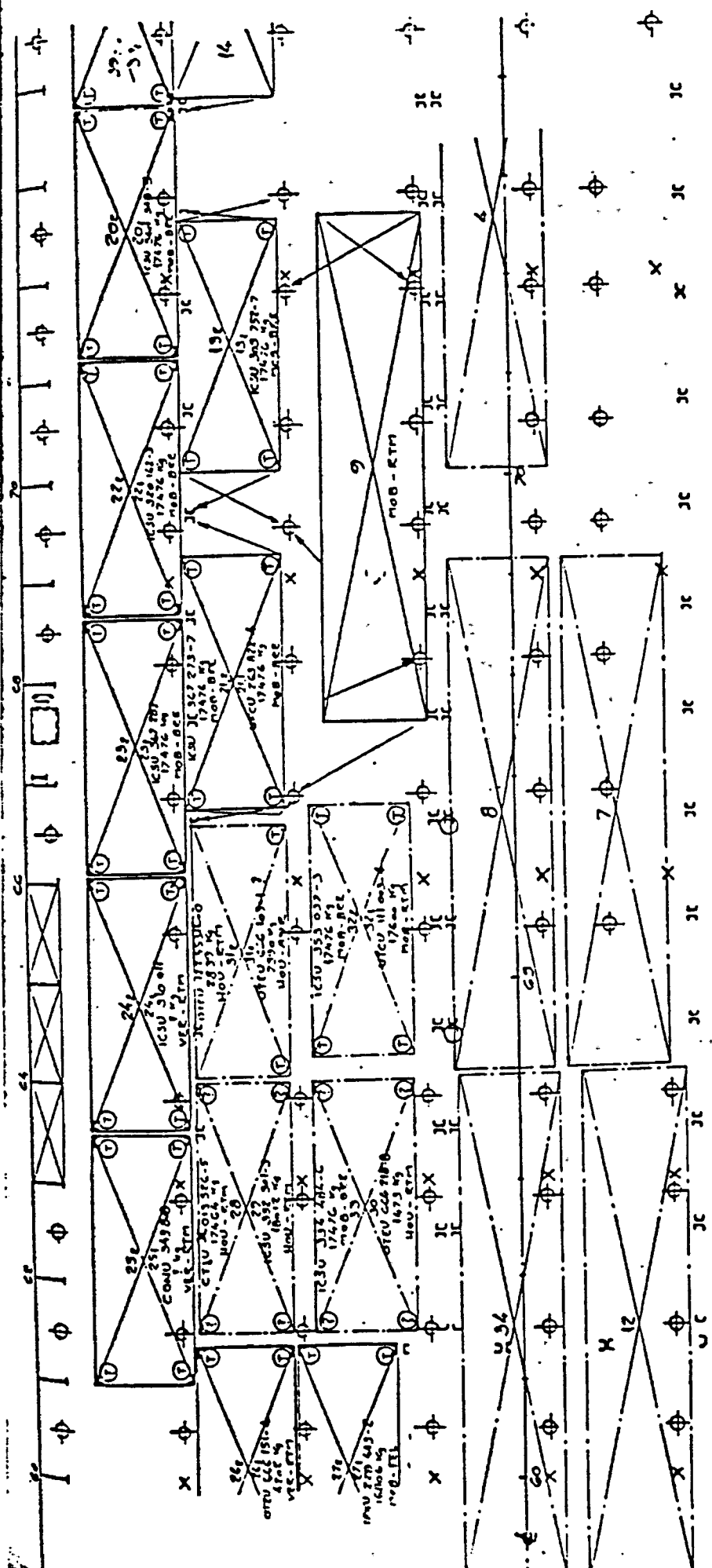

- ⊠ = Container fitting for sliding cone.
- ⊙ = Lashing fitting for elephant foot.
- X = Lashing fitting below deck.
- = Chain lashing 11/13 mm.
- ① = Twist lock between lower and upper units.
- ② = Locking between units unknown.
- ③ = Damaged container fitting.

2ND DECK

- 5' container : 13, 18, 20, 21, 21a, 22, 22a, 23, 23a, 24, 24a, 25, 25a, 26, 27, 28, 29, 30, 31, 33.
- 5' stackmaster : 30, 31, 261.
- 5' platform : 312.
- 5' tank container: 271, 321.
- fr. trailer : 4, 7, 8, 9, 12, 34.
- o' container : 14, 321a.

have been standing on dunnage.

According to information in manuals the coefficient of friction between dry wood and steel is 0.5-0.6. At two lashing chains in each end of the containers and with a cargo weight of 35 tons, distributed on two units of similar weight and with a ship's heel of 40degr, the force will be 11.7 tons in both lashings or about 6 tons per chain (see attached graph giving lashing force in function of heel angle and the coefficient of friction)

On board there were chains of the dimension 11mm as well as 13mm. The breaking point for these chains is 14.5 and 20 tons respectively.

In connection with the shifting of units 32 and 32', these probably slid off the dunnage, upon which the coefficient of friction has changed to 0.15 which is the reference value for static dry friction steel-steel. On the day of the accident, it was reported that the unit 32' containing synthetic rubber has leaked out. This has contributed to lubricating the deck and the coefficient of friction will probably had sunk to about 0.10. This low coefficient of friction is probably a contributing factor to the fact that it was impossible on board to keep these units(32 and 32') in their lashings after being able to catch and lash them tight twice. The units had been lashed to the deck. At a heel angle of 40degr and a coefficient of friction of about 0.1 a lashing force of 23.6 tons or about 12 tons per chain would be required. These values assume that no dynamic effects occur from slack chains or movable cargo inside the containers. The units 32 and 32' had been lashed only from the top container's upper corner casting up under deck. There was no possibilities to keep them in their stowage place by a heeling angle of 40degr and a coefficient of friction of 0.1.

\* Damage on lashing equipment.

Damage on lashing equipment, both fixed and loose, was noted in a number of places in the ship. Some legs of the U-shaped fixed container fittings had broken

in several places both on second deck and upper decks. In the area where the two containers had tipped towards starboard on upper deck, it was noted that the U-frames in the deck had opened and let go of their grip on the respective sliding cone. Some locking pins were bent and in some places the locking pins had slipped out of their own sliding cones. Damage on twistlocks was only noted in one case, namely at the two aft tank containers on the starboard side on upper deck. A great number of damaged tension levers were noted.

#### 2.1.1.7. Conclusion and Recommendations of the Maritime Investigation Commission.

The ship was seaworthy and had required stability during the voyage. She was properly manned. West of the Orkney Islands(UK) the ship was caught in a storm, hurricane-force winds and a rough sea. During the later part of the voyage, the ship rolled severely and on certain occasions with a heel angle of up to 40degr. The refrigerated trailers were equipped with charged starting batteries placed without protection. Certain units of the ship's cargo began to shift on second deck for not being satisfactorily secured. The commission has found that the fire was caused by the coming adrift of several cargo units on second deck in the rough weather. One of these, a tank container with trimethylphosphite, struck a reefer trailer and as a result the tank container was damaged to such an extent that its contents ran out on deck. These contents then reacted with acid from damaged batteries belonging to the refrigerated trailer. Inflammable vapours were thus generated. The fire had then begun, in all probability, through the creation of sparks from the damaged batteries. Because of the fire, heat, smoke and poisonous and irritating gases were developed to such a degree that the ship had to be abandoned. The puncturing of the tank container and the creation of sparks were caused by part of the cargo not having been satisfactorily secured.

The commission considers that the question of the securing of cargo on Ro/Ro ships, a question that has for some time been under examination by the Transport Research delegation with the support of shipowners and several other interested parties. Special attention should be paid to containers carrying dangerous goods. The National Swedish Administration of Shipping and Navigation should take action to ensure that the current work being done within IMO in relation to recommendations for the "Cargo Securing Manual" is completed as soon as possible and the recommendations put into force.

Truck batteries of accumulator type, such as the starting batteries on the refrigerator unit of reefer trailers, ought to be transported with maximum protection from external damage. [31]

#### 2.1.2. The Case of Vinca Gorthon.

The Swedish Ro/Ro-ship Vinca Gorthon capsized and sank in the North Sea on February 28-29, 1988. The accident, which caused no loss of life, has been investigated by the Swedish Maritime Investigation Commission which has produced a comprehensive report.

##### 2.1.2.1. The main particulars of Vinca Gorthon.

The Vinca Gorthon, a modern Ro/Ro ship was built in 1987 and delivered to the owner on April 1, 1987 after the approval of the stability book by the National Swedish Administration of Shipping and Navigation on March 27, 1987. The ship's length over all is 166.00m and moulded breadth 18.45m. Her gross tonnage is 18,773 registered tons and net tonnage 6,392 registered tons. The ship's deadweight is 10,945 tons on summer and the displacement on summer freeboard is 18,279 tons. The ship's normal speed is 16.5 knots. She is designed for the carriage of wheeled cargo, containers and goods on pallets. Her cargo capacity is:

- 160 units of roll trailers(40ft-12.3x2.5x4.3 max)

- 145 containers of 20ft on main deck and 24 on weather deck
- 100 Automobiles on upper deck

According to the stability book, the GM-value for the condition that gave the lowest value was 0.376m. The value of 0.8m was approved by the shipowners.

Vinca was equipped with a cargo computer on board. In order to reduce rolling at sea and to compensate for heeling during loading and unloading in port, there was a tank system which consists of three pairs of tanks located in the forebody on the outer side of the cargo hold on main deck. The anti-heeling function was initiated by a gyro which governed airvents on the tank tops. The anti-rolling function was based on a partly passive system where the water always reached the tank on the lower side when this was on its way up. The steering engine was hydraulic. Pressure oil was supplied by two electrically driven hydraulic pumps that could be operated each at a time or, for quick rudder movements both simultaneously.

#### 2.1.2.2. The loading on board at the departure.

Two loading ports were respectively called by Vinca: Husum and Oskarshamn. The cargo from Husum consisted of 173 rolltrailers of which 21 were 20ft trailers and 152 were 40ft trailers. On the weather deck there were also seven 20ft-containers and five MoDo tank units. In addition there was on board an automobile belonging to the boatswain. After the unloading and loading of rolltrailers at Oskarshamn, there were on board 170 rolltrailers, of which 21 were 20ft-trailers and 149 were 40ft-trailers plus the earlier indicated units on weather deck. Most of the roll-trailers were new with a steel frame and a plywood board as bottom. The cargo consisted mainly of upright paper rolls of different heights and diameters, palletted sheet paper in cardboard boxes and saw wood in bundles. The rows of roll-trailers had a transversal distance between them of 40-50cm.

### 2.1.2.3. The ship's condition before and during the voyage.

#### \* Securing of cargo.

The commission assigned "MariTerm" to make a computed study of the securing of the cargo on the rolltrailers and of the trailers to the deck. The report shows that the lashings that were used to secure the cargo on the ship had a very limited supporting effect, although they were applied properly and the tightening clasps were intact. The total effect of the lashing to prevent tipping is estimated to about 30% of the units' self-stability. The limited effect of the securing to prevent tipping applies for the lashing of the cargo to the trailer as well as for the lashing of the trailer to the ship deck.

The calculations show that the accelerations of the ship during the five hour period in question very likely reached value that implied that the critical stability point of the cargo and the trailer was exceeded and that a shifting of the cargo occurred.

\* The ship's stability conditions at the time of accident.

Cargo:	8,493 tons
Bunkers	230 tons
Fresh water	100 tons
Ballast	917 tons (130 tons in stability tank "A")

General addition 150 tons

Total DW.	9,890 tons
Light ship	7,334 tons
Displacement	17,224 tons

Draft at Oskarshamn (sea water density: 1010) : F= 6.47m and  
A= 7.02m

Cleared draft in Kiel canal 7m

GM-value = 0.75m

The position of the center of gravity has been calculated on the basis of the cargo plan, the rolltrailer reports, a transcription of the cargo-tallying instrument regarding tank contents. After these calculations, it is noted that the center of gravity for the cargo was 0.169m to port. In order to ascertain how much the transversal stability changes in a wave, righting-arm(GZ) curves have been calculated for different positions of the ship in a regular wave with a length of 105m, a height of 6m from trough to crest and coming in 45degr on the bow. The Vinca had the waves coming in 45degr-50degr on the starboard bow at the time of the accident. The calculations indicate the following:

- the ship will lose most righting moment when a wave crest is immediately abaft the center of the ship longitudinally;
- the righting moment will on an average be greater when passing through a wave than in a calm sea;
- when the waves come in on the bow, the ship loses righting moment compared to having the sea coming in straight ahead, up to about 35degr heeling. A 45degr sea on the bow gives the least righting moment in this heeling interval, but also gives the greatest moment for heeling angles above 35 degrees for the examined wave directions.

\* The course of events.

The Vinca left Oskarshamn on Friday February 26 and proceeded to Kiel Canal normally. She left Brunnsbuettel on Saturday night and passed out into the North Sea(via Elbe) on Sunday at 01.15hr and then followed the traffic separation towards Terschellingerbank. A northwesterly wind was blowing which, according to the master increased to 8-10 Beaufort when the Vinca got out into the shipping lane. The weather had gradually deteriorated during the voyage and a strong wind pressure from starboard caused a list of about 3degr to port. Around 15.35 hours both the chief officer and the officer on watch were on the bridge when they heard a thud.



They were doubtful about what had caused the thud. AT the same time the boatswain had heard also the thud, which he thought came from the cargo hold. The boatswain decided to check the cargo on the upper deck where he saw a trailer tumbling about the lashings, leaning 20degr to port and bumping again a bulkhead which connected to weather deck under the deckhouse. Suddenly he also saw rolls(paper) starting to fall from a trailer which was forward on the starboard side. The officer on watch was stated that the Vinca 3-5 minutes after the thud started heeling over to port 20degr, maybe 25degr, then to come back again to between 5-10 degr. According to the officer the Vinca then began to heel over slowly to port to a position between 35degr and 45 degr. A short while after the turn had been initiated, one of the hydraulic pumps to the steering engine stopped. After a further 40 minutes also the other pump stopped, which resulted in the rudder being locked in a starboard position. On board, the heeling was felt as increasing. In this situation the master decided that the ship should be abandoned. The evacuation of the crew was completed at around 18.45 hours. Vinca's list increased gradually. At 07.30 hours on February 29 Vinca was reported sinking slowly at the position N52degr46' and E04degr12'.

#### 2.1.2.4. The Commission Considerations.

\* Regarding the ship.

The calculations concerning the influence on stability in a static wave pattern indicate that the ship in a certain position vis a vis a big wave may lose its stability. In reality, great variations of stability due to waves are significant only when the encounter period is very long(following sea with comparatively short waves) or when the encounter period is half of the ship's natural period when rolling(risk of Mathieu resonance).

On the voyage in question Vinca had more cargo and less ballast than at any other earlier voyage. The GM-value was

slightly less than the shipowners had recommended(0.8m), but more than the requirement of the National Swedish Administration. Calculations made within the commission show that a greater GM results in increased lateral accelerations which increase the risk of cargo shifting. The resulting list after a shifting of the cargo is less, however. A lower GM reduces the lateral accelerations, but induces greater heeling angles during rolling and a greater list after a shifting of cargo.

\* Regarding the cargo.

The loading system that was used on Vinca was based on experience from many years' transport of similar cargo in other ships. The ships, that had been utilized before had also carried such trailers, but these had been lighter and had constituted a smaller part of the cargo which otherwise did not consist of rolling cargo. The lashing of the cargo to the trailer in MoDo's plant in some cases was done in a less appropriate manner. The tightening of the bands over that part of the angle was less effective. Through the vibrations the cargo was exposed to when it was brought on board the tightening was probably reduced. When the ship was sailing the tightening probably also deteriorated because of the motions of the ship. There were only limited opportunities of re-tightening the bands on board because of the narrow space between the trailer rows and the risk it implied for the crew to move about in the cargo hold when the ship was in motion(see Annex). Another weakness of the system, in the opinion of the Commission is the securing of the trailer to the deck. The chosen method of crossing the bands does not appreciably prevent tipping of the equipment. Because of the location of the lashing brackets, some lashings get too near each other, which makes it difficult to re-tighten the bands. By that the risk of tipping increases as the trailer is not rigidly secured to the deck.

According to the calculations made by MariTerm and the practical tests scale carried out by MoDo show that loaded trailers lashed as on Vinca, can tolerate a maximum tipping or sliding angle of between 15 degrees and 20 degrees depending on the type of cargo and the degree of tightening. When the shifting of the cargo occurred, Vinca had the sea and wind mainly on the starboard beam and was rolling according to the master's estimate between 4degr to starboard and 10 degrees to port. Because of the motions of the ship, the cargo was exposed to vertical as well as lateral accelerations. This may have implied that the cargo got a tendency of "creeping" towards port. As Vinca for several hours had been sailing in rough sea with some list to port because of the wind pressure, it is not unlikely that several cargo units had got their center of gravity slightly shifted towards port. It is relevant that already a shifting of the center of gravity by 0.1m corresponds to a reduced tipping angle of a couple of degrees.

The calculations made within the Commission show that significant lateral accelerations in the prevailing sea are within the range 0.7m/ss-1.0m/ss. The corresponding vertical accelerations have been calculated to be within the range 0.7m/ss-1.5m/ss, depending on the stowing of the cargo on the ship. The probable maximum value for the accelerations during the voyage up to the accident are estimated to be two time greater than the significant value.

Thus the Commission is of the opinion that the wave-induced accelerations on the cargo in the prevailing sea conditions at one moment became so high that a considerable part of the cargo worked loose and shifted towards port. This in its turn caused the center of gravity of the ship to move so that ,at a subsequent heeling to port, the rest of the cargo shifted and got stacked against the port side of the ship. This resulted in the list of 32 degrees-36 degrees.

According to the opinion of the Commission, the weather

conditions did not differ from what can be expected for navigation in the North Sea. That in spite of this the cargo did not endure the forces it was exposed to indicates that the cargo securing system was inferior. The cargo was imperfectly and inadequately lashed and secured with regard to the lashing of the cargo to the rolltrailers as well as the securing of the trailer to the deck of the ship.

#### 2.1.2.5. Conclusion and Recommendation of the Commission.

\* The result of the investigation.

- The ship was seaworthy and had the required stability;
- The ship was manned according to the regulations.
- No technical defects of the ship have been discovered;
- Vinca was exposed to strong northwesterly wind and heavy sea coming in on starboard beam or slightly on the forward beam;
- Due to wave-induced accelerations the cargo was exposed to such strain that it completely shifted towards port;
- The cargo was imperfectly and unsuitably lashed;
- The shifting of the cargo resulted in a list of 32-36 degrees;
- Due to the list water entered through the gooseneck ventilators into the hydraulic-pump room of the ship, knocked out the steering engine and put Vinca out of control;
- Vinca was gradually flooded and sank
- Those on board were rescued from Vinca by Dutch life-saving service;

\* The cause of the accident.

In rough sea, Vinca's cargo was exposed to such strain that it shifted. The shifting of the cargo resulted in Vinca taking such a pronounced list that water flowed into her, which caused the disablement of the steering engine and put

Vinca out of control. The continued inflow of water later led to it that Vinca sank. Conclusive for the accident have been:

- A An inadequate cargo securing system (shifting of cargo);
- A Inappropriately located ventilators to the room where the steering engine's hydraulic pumps were located (the water inflow).

**\* Recommendation.**

The Commission suggests that the National Swedish Administration of Shipping and Navigation should forcefully work towards it that the discussions about the IMO proposal are soon concluded so that the owner of every Ro/Ro ship will have a statutory duty to provide the ship with a manual approved by the proper authorities concerning the lashing and securing of cargo on board. [32]

**2.2. SOME MORE EXAMPLES OF CASUALTIES IN THE LAST 30 YEARS.**

In the last 30 years there are many examples of serious casualties and total losses of dry cargo ships caused by shifting of cargo. These examples which are representing a complement to the case studies are the following:

\* In 1966 the Greek passenger steamship "HERAKLION" which had been on her regular run from Canea, Crete to Piraeus capsized on December 8, at 02.05 a.m. with 264 passengers on board from whom only 47 were rescued. The Heraklion flooded immediately after a 16-tons refrigerated lorry broke free during the storm and smashed into the forward starboard side loading door, ripping it free.

\* In 1967 six crew members died and a further eight remained missing, presumed drowned, when the Norwegian general cargo motor vessel (1,112 gross tonnage) Dux capsized and sank due to her cargo of fertilizers shifting in heavy sea in Boknfjord, north of Stavanger, on September 3, 1967. The Dux had been on voyage from Glomfjord to Oslo at the time

of incident.

\* In 1969 on the American steamship "Badger State" twenty-five men were lost following an explosion and fire on board on December 26, 1969, about 580 miles north-east of Midway Island one hour after her cargo shifted in heavy sea.

\* In 1970 all 10 members of the crew of a West German motor vessel were rescued from rubber dinghies after she sank 13 miles south-west of Goeree Light-vessel in lat. 51degr51'N, long. 03degr35'E, on November 18, 1970, after developing a heavy list. She had just sailed from Antwerp bound for Rauma with a cargo of steel wire ropes which shifted in a heavy gale causing the loss of the vessel.

\* In 1972 on the Cyprus general cargo motor vessel "Cape Sable" thirteen crew members lost their lives when the ship sank about 100 miles west of La Coruna in lat. 43degr20'N long. 09degr20'W, on December 17, 1972, after her cargo shifted during a heavy swell and storm force winds. The Cape Sable had been on the voyage from Antwerp to Algiers with a general cargo.

\* In 1973 the Somalia general cargo motor vessel "Captain Niko, on voyage from Rotterdam to Alexandria loaded with a cargo of 9,100 tons of ammonium sulphate fertiliser, was abandoned by her 22-man crew in the English Channel off Guernsey on May 4, 1973, after her cargo shifted during gale-force weather.

\* In 1979 from a crew of 31, there were only eight survivals when the French general cargo motor vessel "Francois Vieljeux" of Societe Navale Chargeurs Delmas Vieljeux" sank about 30 miles off Vigo in lat. 42degr05'N, long. 09degr31'W, on February 14, 1979, after her cargo shifted during violent storm force 11 winds and mountainous seas. She had been on voyage from Mombassa to Antwerp, carrying a cargo of tea, coffee, Zambia copper and zinc.

\* In 1981 there was only one survival from a crew of 24 on board the West-German general cargo/container motor vessel "Elma Tres" (7,470 gross tonnage) when she capsized due

to loss of power and shifting of containers during heavy weather, and then sank 215 miles east of Bermuda lat. 32degr 17'N, long.60degr30'W, on November 26, 1981. The Elma Tres had been on voyage from Buenos Aires to Savannah, carrying 600 containers of general cargo.

\* In 1982 the Panamanian general cargo motor vessel "Brilliante" was on the voyage from Cayenne to Maracaibo, loaded with a cargo of lumber, when she sank in heavy weather conditions off the coast of French Guiana in lat.04degr56'30" N, long.52degr10'00"W, on November 25, 1982, after her cargo shifted and pierced her shell plating in way of her hold.

\* In 1983 the Greek general cargo motor vessel "Christoforos" was on voyage from Volos to Algeria, carrying a cement cargo, when she sank off Skopelos Island after her cargo shifted in heavy weather on October 3, 1983.

\* In 1984, while en route from Dean Quarry, near Porthoustock, southern Cornwall, for London, loaded with a cargo of granite chippings, the British general cargo motor vessel "Fylrix" sank in Jennycliff Bay, Plymouth Sound, at about 3 a.m. on November 22, 1984, after her cargo shifted in severe gale-force weather conditions when 10 miles off the Eddystone Lighthouse during the previous evening. No lives lost, but the vessel was declared as a constructive total loss, the wrecked vessel was abandoned.

\* In 1985 there was only one survival from a crew of 25 when the Polish general cargo motor vessel "Busko Zdroj" sank in the North Sea about 80 miles north-west of the island of Heligoland in lat.54degr52'N, long.06degr00'E, on February 8, 1985, after her cargo of steel products shifted in heavy weather conditions while she was on voyage from Gdansk to Porto Torres, Sardinia.

\* In 1986 the Dutch general cargo motor vessel "Angela Smits" was on voyage from Porsgrunn, Norway, to Rockhampton, Queensland, with a cargo of 6,000 tons of ammonium nitrate, when she developed a heavy list south-west of Penmarc'h, north-western France, in about lat.47degr38'N

long.07degr46'W, on February 26, 1986 after her cargo shifted in heavy seas.

\* In 1987 all seven crew members and three passengers died when the Greek general cargo motor vessel "Nikolaos L." capsized and sank in the Aegean Sea near the island of Thassos in lat.40degr40'N, long.25degr10'E, on January 18, 1987, after her cargo of 630 tons of bricks on pallets shifted in heavy seas and gale-force winds.

\* In 1988 the Cyprus container-ship "Lloyd Bermuda" was abandoned by her eleven crew members when she capsized 250 miles east of Delaware Bay on December 28, 1988 after the cargo on board the vessel had shifted in a storm. The Lloyd Bermuda was on voyage from Newark to Bermuda.

Due to ship motions at sea in bad weather, it is necessary to secure the cargo in one way or the other on board ship to prevent casualties. In what manner the cargo is secured depends on the ship and the type of cargo to be shipped. As can be seen in the case studies and the examples described the shifting of cargo on board ships (Ro/Ro-ships, Container-ships, General Cargo-ships etc.) is a reason for many casualties. For instance in the statistics of Ro/Ro-ships casualties, the cargo shifting, together with operational reasons, constitutes a larger part of the serious casualties, (16% of the total of serious casualties between 1965 and 1982. Also 43% of total losses of Ro/Ro-ships are caused by shifting of cargo. These statistics, valid for Ro/Ro-ships, are taken from "Det Norske Veritas" casualty statistics. [8]; [30]



## PART TWO

# ANALYSIS OF PRACTICAL SOLUTIONS AND THE WAY OF PLANNING AND IMPLEMENTING THE SAFE STOWAGE AND SECURING OF CARGO.

The proper stowage and securing of cargo is of the utmost importance for the safety of life at sea. Shifting of cargo on board a ship can cause damage to the cargo and risk to the safety of the ship. The ship can either have too high or too low stability due to unsuitable design or unsuitable cargo distribution and considerable accelerations may occur on board.

Improper stowage and securing of cargo has led to numerous serious ship's casualties, where many injuries and losses of life have been registered. In the recent years, there have been a number of accidents involving shifting of semi-trailers and general cargo in Ro/Ro ships, especially in short-sea traffic. As it was already mentioned in (Part One) of this paper cargo shifting, together with operational reasons, constitute a larger part of the serious casualties than of all casualties: 16% between 1965 and 1982 and 12% of the total loose. Furthermore, 43% of the total losses of Ro/Ro ship are caused by shifting of cargo or are due to operational reasons (e.g. discharging). Statistics valid for Ro/Ro ships are taken from Det Norske Veritas-casualty statistics.

In 1987, a working group within the BC. Sub Committee of IMO has formulated a draft of a new code of safe practice for stowage and securing of cargo. In this draft, the complex problem of securing the variety of today cargoes in different types of ships is organized in three distinguishing categories

- standardized stowage and securing systems in which the master should follow comprehensive instructions which are based on precalculations carried out by shipyard or suppliers

and accepted by authorities;

- semi-standardized stowage and securing arrangements which are similar to the standardized ones, but the instructions are less comprehensive due to the greater variety of semi-standardized units, therefore given more in form of typical examples. This demands some degree of interpreting ability from the master and his officers;

- non-standardized stowage and securing of cargo, with which the full decision process is left to the master and his officers to achieve a proper cargo stowage and securing at reasonable costs very often in disagreement with the charterer's supercargo.

From this situation, it seems good to come to an international agreed calculation method, which, in cases of doubt or discussion should provide results to be referred to. In order to deal with the problems and hazards arising from improper stowage and securing of certain cargoes on ship, IMO has given guidelines in the form of either assembly resolutions or circulars adopted by the Maritime Safety Committee (MSC); these are listed as follows and appear in full in the annexes to this code:

- Safe stowage and securing of cargo units and other entities in ships other than cellular container ships,  
Resolution A.489.XII (Annex1);
- Provisions to be included in the Cargo Securing Manual to be carried on board ship,  
MSC/CIR.385 (Annex2);
- Elements to be taken into account when considering the safe stowage and securing of cargo units and vehicles in ship,  
Resolution A.533.13 (Annex3);
- Guidelines for securing arrangements for the transport of road vehicles on Ro/Ro ships,  
Resolution A.581.14 (Annex4);
- IMO/ILO guidelines for packing cargo in freight containers or vehicles.(Annex5)

- Hazards associated with the entry into enclosed spaces, MSC/Cir.487 (Annex6);
- Measures to prevent overloading of containers, MSC/Cir.489 (Annex7).

All these guidelines or circulars are based on some general principles which can be summarized as follows:

\* All cargoes should be stowed and securing in such a way that the ship and persons on board are not put at risk.

\* The safe stowage and securing of cargo depend on proper planning, execution and supervision.

\* Personnel planning, and supervising the stowage and securing of cargo should have a practical knowledge of the application and content of the "Cargo Securing Manual", if provided.

\* In all cases, improper stowage and securing of cargo will be potentially hazardous to the securing of other cargoes and to the ship itself.

The aim of this second part of my project, is to analyse the practical solutions, which may be applied to the problem of proper stowage and securing of cargo and finally, find some ways of planning and implementing safe stowage and securing of cargo.

### CHAPTER 3. ENVIRONMENT AS PARAMETER FOR SHIP'S OPERATION.

The aim of ship operation is to carry goods between different points and arrive safely at destination.

This aim is greatly influenced by the environmental system, which is defined by the following variables: state of weather, sea, wave parameters, current, tidal streams, ice, sea temperature, depth and etc.

Ship's motions at sea have always been a problem for the naval architect. His responsibility has been to ensure not only that the ship can safely ride out the roughest storms, but that it can proceed on course under severe conditions with a minimum of delay, or carry out other

specific missions successfully. Maintaining the schedule now depends as much on ship motions in operational environment as on available power.

The understanding of ship motions at sea and the ability to predict the behavior of any ship or marine structure in the design stage, begins with the study of the nature of the ocean waves that constitute the environment of the seagoing vessel.

### 3.1. DESCRIPTION OF THE ENVIRONMENT.

#### 3.1.1.- Seaway.

The outstanding characteristic of open ocean waves is its irregularity, not only when storm winds are blowing, but even under relatively calm conditions.

On basis of the assumption that a large number of regular waves having different lengths, directions and amplitudes are linearly superimposed, oceanographers have found that, irregular seas can be described by statistical mathematics (mathematical models). The essential feature of these models is the concept of a spectrum, defining the distribution of energy among the different hypothetical regular components having various frequencies (wave length) and directions. It is shown that various statistical characteristics of any seaway can be determined from such spectra. It has been found that the irregular motions of a ship in a seaway can be described as the linear superposition of the responses of the ship to all the wave components of such a seaway. This principle of superposition requires knowledge of both the sea components and the ship responses to them. These ship responses or ship motions can be categorized into two different types:

- the longitudinal motions of pitch-heave-surge
- the transverse motions of roll-sway-yaw.

##### 3.1.1.1. Sea waves.

It is shown that, knowing the wave spectrum and the

characteristic response of a ship to the component waves of irregular sea, a response spectrum can be determined. From it various statistical parameters of response can be obtained, just as wave characteristics (wave period and height) are obtainable from wave spectra.

Analysis of wave records has also shown that, wave elevations read at regular time intervals have roughly a Gaussian or normal probability density function. However, for an overall understanding, as well as for solving some seakeeping problems, the variation in waves over long periods of time and over great distances cannot be overlooked. It is useful, therefore to review the physical processes of storm wave generation and of wave propagation in a general way. Storm waves are generated by the interaction of wind and the water surface. There are at least two physical processes involved, these being the friction between air and water and the local pressure fields associated with the wind blowing over the wave surface. Within the storm area, there will be wave interactions and wave-breaking processes that will affect and limit the growth and propagation of waves from the many local disturbances. A second important characteristic of water waves that affects the propagation of wave system is that in deep water the phase velocity of a simple regular wave, is a function of wavelength. Longer waves travel faster than shorter waves.

The energy in a train of regular waves consists of kinetic energy associated with the orbital motion of water particles and potential energy resulting from the change of water level in wave hollows and crests.

#### 3.1.1.2. Waves in the open Ocean.

The statistics of wave records are provided in two different terms:

- a long-term statistic, which is a combination of the wave period ( $T_w$ ) and wave height ( $H_w$ ), gives a statistic for all voyage over month, season and year;

- a short-term statistic which gives a statistic for hours, minutes and etc.

Particular attention is given to the short-term statistics of responses such as pitch, heave and roll both motions and accelerations.

\* Short-term statistics.

To be able to define a seaway, it is necessary to take sample records of the wave heights and frequency of the particular seaway concerned over a limited period.

In addition, the wave pattern will never be repeated. The statistical characteristics of the sea state, that is the energy spectrum or wave spectrum will remain the same. In other words, the sinusoidal components that approximate a record for a particular sea state are the same regardless of time and place and differ from one record to another only in phase orientation, thereby keeping the same energy of the wave system constant. It is often preferred to obtain the average wave characteristics for any given area by taking many samples of wave records. The spectral density curve may be approximated by an analytical expression based on probability theory.

$$S(\omega) = d\omega = \frac{1}{2} \sum \omega^2 \zeta_{ai}^2; \quad \zeta_{ai} = \text{wave amplitude}$$

The energy spectrum of the seaway does not have a Gaussian form, but the seaway record (histogram) for wave elevation does have the Gaussian form. The histogram for the wave heights of irregular seaway is considered to be more or less a Rayleigh distribution. The energy spectrum may have any functional form. To use the principle of energy spectrum for study, the quantitative values of the wave spectrum for different sea regions and for different climatic conditions should be known.

Generally speaking and to make easy the calculations, the spectral density is used to represent the full energy of the component waves. This energy is directly related to the square of the wave amplitudes, that means the spectral density  $S(\omega)$  can be directly related to the square of the

amplitude of the waves and the area under the curve is equivalent to the statistical variance. ( See graphs.)  
The following useful information can be derived from a wave spectrum:

- the range of frequencies that are important for the contribution of energy of the seaway;
- the frequency at which the maximum energy is supplied;
- the content of energy at different frequency bands;
- the existence of a swell at low frequencies. For the

open ocean, the International Towing Tank Conference (ITTC) has standardized the use of the following spectral formulation:

$$S(\omega) = A \omega^{-5} * \exp(-B/\omega^4)$$

is the circular frequency in radian per second.

$$A = 173(H)^2 / T_1^4 \quad \text{and} \quad B = 691 T_1^4$$

H = significant wave height  
T<sub>1</sub> = significant wave period

A and B depending on the seaway.

\* Long-term response.

In order to determine meaningful criteria for design purposes, estimates of wave induced responses are based on the probable maxima in the ship's lifetime. The long-term probability of a wave induced ship response is obtained by multiplying the short-term probability of that response at a particular sea-state by the probability of obtaining that sea-state and summing over the entire sea-state range. Output is in the form of a curve of response against probability which is used after correlation with measurements to estimate maximum values for particular return periods or in its entire, the load spectrum for fatigue analyses.

### 3.1.1.3. A ship in waves.

The absolute period of the waves may not be the same as the period of the waves encountered by a ship during its

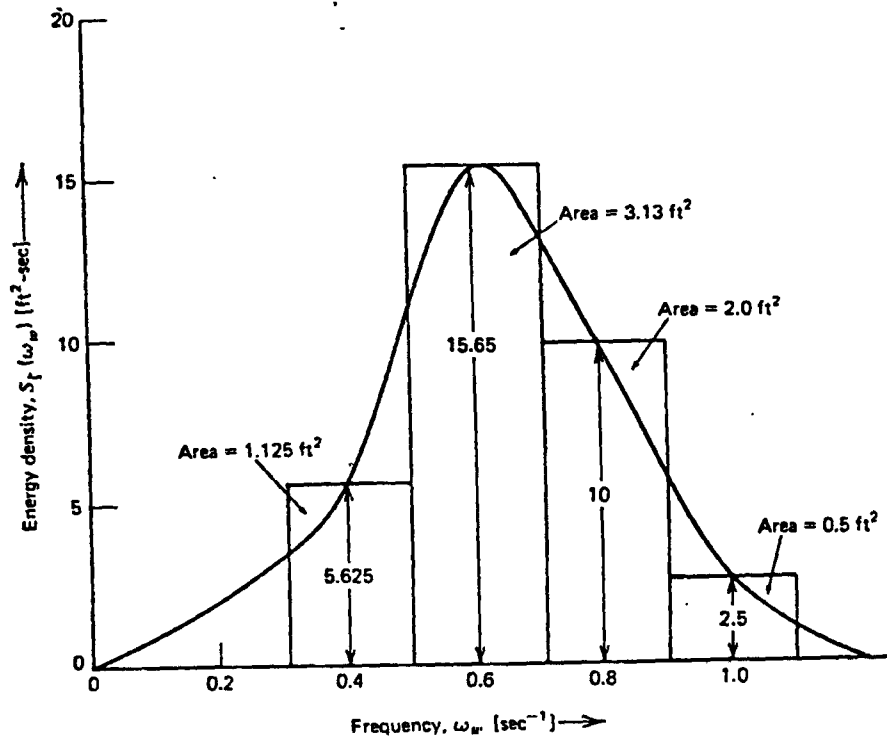

Figure 5.13 Wave spectrum for four waves.

47A

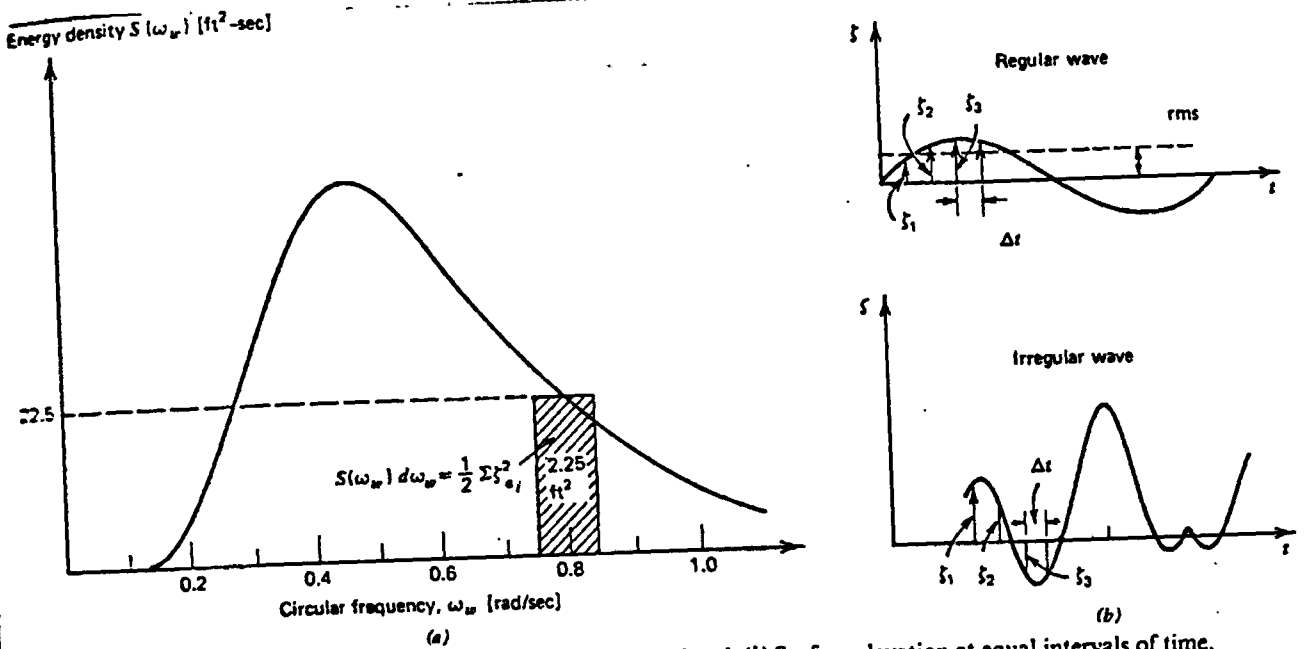
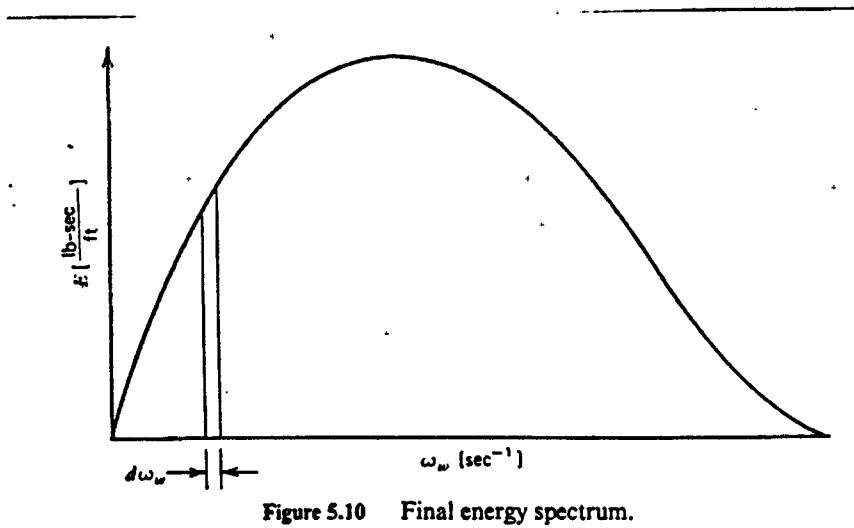
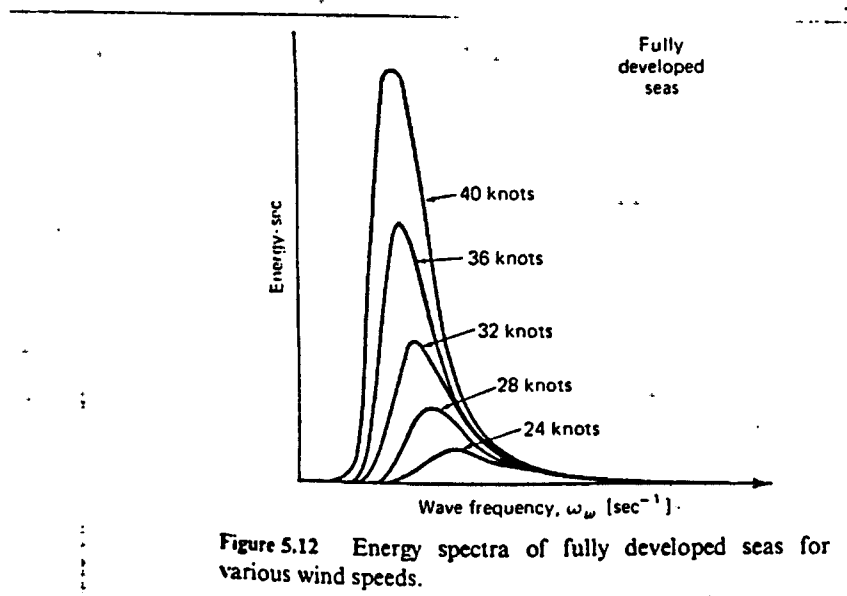
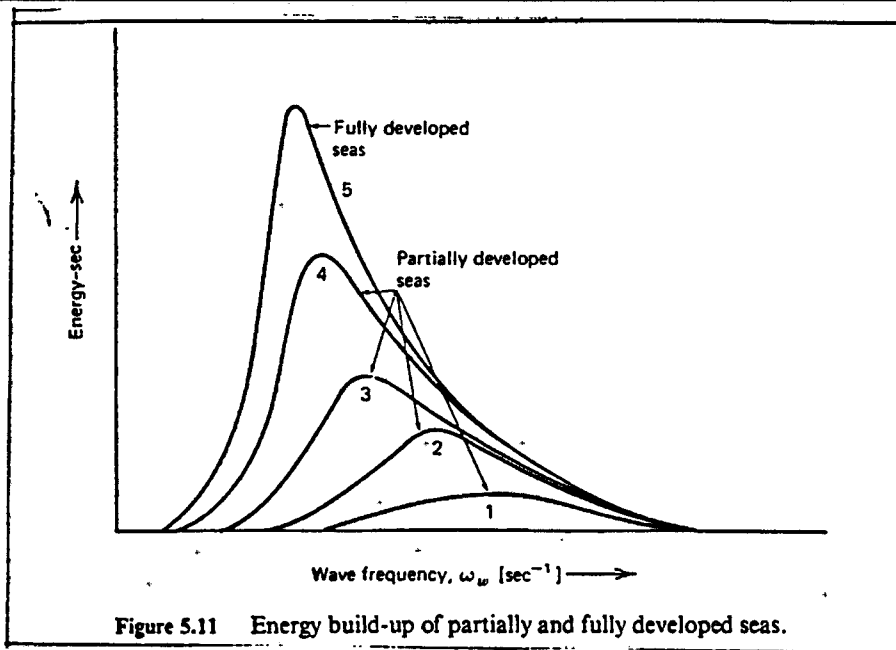

Figure 5.14 (a) Energy density for a particular frequency band. (b) Surface elevation at equal intervals of time.





travel. A ship heading directly into waves (ship in head sea) will meet successive waves quickly and the waves will appear to have a much shorter period.

On the other hand, a ship moving in sea coming from astern (ship in following sea) will move away from the waves, which will then appear to have a longer period. If the waves approach a moving ship from the broadside, there will be no difference between the absolute period of the waves and the apparent period of the waves which are encountered by the ship. This period is known as the encountering period ( $T_e$ ). It is a function of the absolute period of the wave, the ship speed and the angle between the direction of wave travel and the direction in which the ship is heading.

The encountering period  $T_e$  is the important consideration in regard to ship motion in waves, since it tells how the ship meets the waves which then affects the motion of the ship.

$$T_e = L_w / (V_w - V \cos \alpha)$$

$L_w$  = wave length,  $V_w$  = wave speed,  $V$  = ship's speed

$\alpha$  = encountering angle between the direction of the wave travel and of the ship's heading. [4];[20]

### 3.1.2. Wind.

#### 3.1.2.1. General.

Wind is defined as the horizontal movement of air across the surface of the earth. The direction from which it blows and its speed are its important characteristics. It is also the movement of air set up in the atmosphere by differences in atmospheric pressure between two localities. These differences in pressure are caused by variations of temperature in columns of air over different places. It is commonly observed that the wind blows direct from high to low pressure, but it tends to blow in circular manner around regions of low pressure or high pressure because of the influence of the earth's rotation.

The change of pressure over unit distance at right angles to the isobars is called the horizontal pressure gradient which is steep when the isobars are close together, and slack when they are far apart. The force due to the horizontal pressure gradient is called pressure gradient force. The geostrophic force (so called because it relates to the earth's rotation about its axis) causes an air particle to be deflected to the right of its line of motion in the northern hemisphere, and to the left of its line of motion in the southern hemisphere. The geostrophic force per unit mass is:

$$F_g = 2 * V * \Omega \sin \varphi .$$

$\Omega$  = angular velocity of the earth

$\varphi$  = latitude

V = speed of air.

At equator, this force is equal to zero because ( $\varphi$ )=0 at the equator.

### 3.1.2.2. Estimation of Wind Loads on the Ship Superstructure.

\* The character of the wind over the sea.

Wind velocity profiles above the land are governed by two major features of the flow. The velocity is zero at ground level and turbulence levels are highest close to the ground in the wake of distributed ground roughness. The major variable on land is the height of the distributed roughness, summarized by a roughness length ( $Z_0$ ) which is much smaller than it would be for wind above land covered by solid waves of corresponding height. For wind profiles over the sea the surface moves with the wind and the magnitude of the roughness presented by the waves varies with wind speed. From measurements over the Atlantic (e.g.) in open sea it is possible to express the value of  $Z_0$  in terms of wind speed  $U$  at 10 meters above sea level as:

$$Z_0 = 7.31 * 10^{-7} * U_{10}^2 + 8.68 * 10^{-8} * U_{10}^3 \quad (m)$$

Because the presence and motion of the ship can make ship

board measurement of relative wind velocity highly inaccurate, it is customary to offload the problems of estimating the speed in the approaching wind by basing the wind loading coefficient on wind speeds measured at the standard 10m height above sea level, as quoted in meteorological reports for each sea area.

\* The basis of the wind load estimation method.

For a ship moving forward at velocity (V) into a gradient natural wind whose plane is at an angle ( $\phi$ ) to the direction of motion, the relative wind at the ship is inclined to the longitudinal axis by an amount varying from zero at sea level to an angle less than ( $\phi$ ) at the bridge level (See Fig.3). This is borne out by consideration of the magnitude of the effective resultant relative wind speed for the ship in motion.

For each height above sea level the resultant relative velocity R, from motion at velocity V, through a plane wind of velocity U at an angle ( $\phi$ ) to the direction of motion, is given by the formulas:

$$R_h^2 = U_h^2 + 2U_h * V * \cos\phi + V^2$$

The effective relative wind speed for a ship in motion is virtually identical in magnitude and direction to the resultant of the vector combination of the velocity of motion and the effective wind speed U for the ship at anchor.

$$R_h^2 = U_h^2 + 2U_h * V \cos\phi + V^2$$

With the notations of Fig.3 the value of the effective wind angle under motion can be evaluated from:

$$\tan(\beta - 1/2\phi) = (\bar{U} + V) / (\bar{U} - V) * \tan\phi/2 .$$

$\bar{U}$  = effective windspeed for the ship at anchor.

\* Practical aspects of wind loading calculations

An essential part of wind load estimation is the calculation of conversion factors for each particular design. Simplified frontal and lateral projections of the superstructure above the required waterline are subdivided

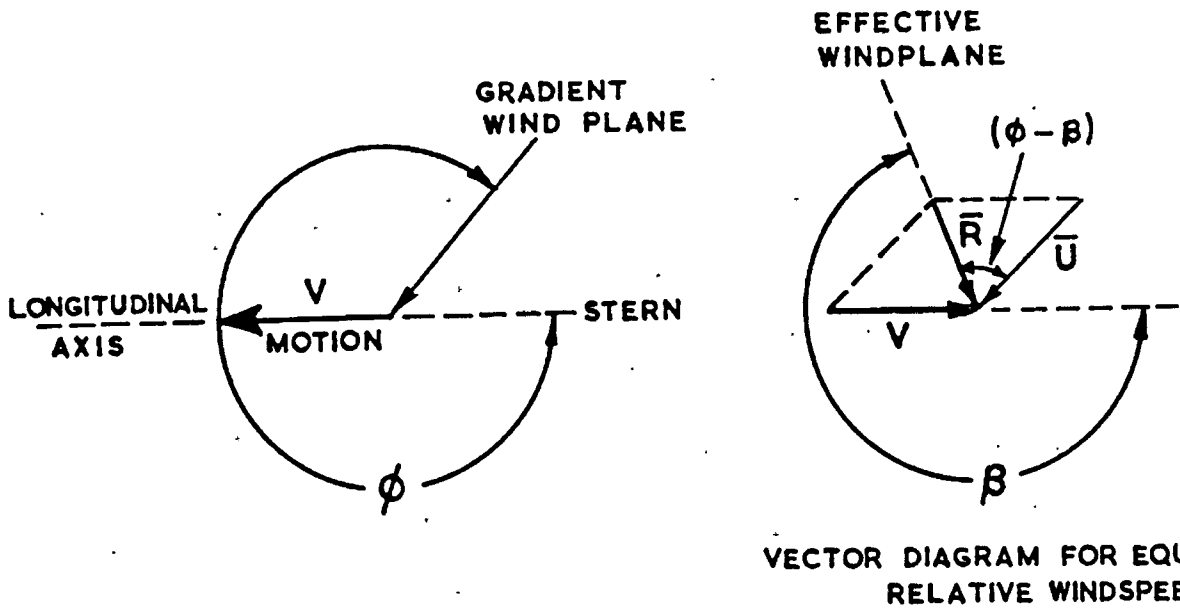

VECTOR DIAGRAM FOR EQUIVALENT RELATIVE WINDSPEED

Fig 3 NOTATION FOR COMBINING EFFECT OF NATURAL WIND AND MOTION

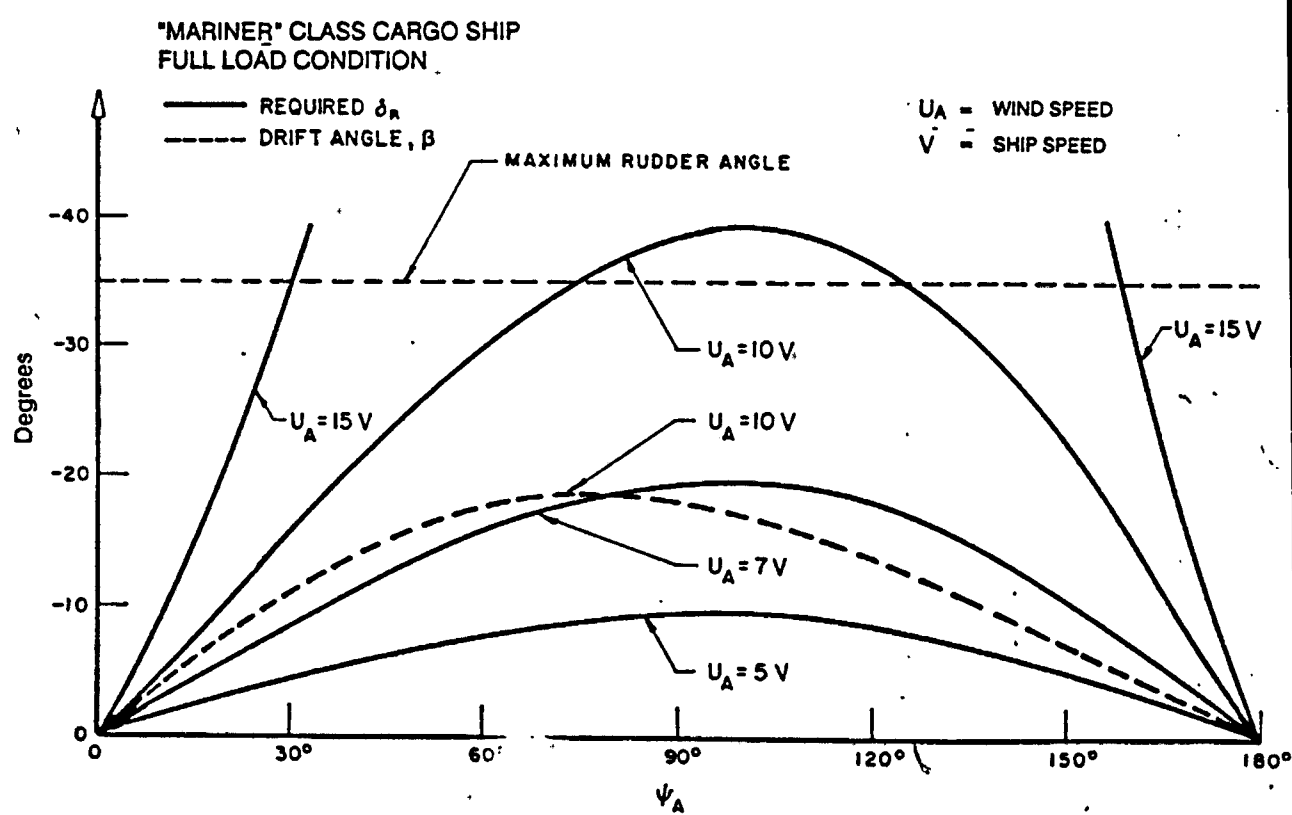

Fig. 5 Required rudder angle versus wind direction (Edo, 1966)

into convenient elements. Each of these elements is bounded by two vertical lines. It has a maximum height (H) and consists of a rectangle of height (rh) and width (b), surmounted by a trapezium of upper width (nb) which becomes a triangle for n=0. (See Fig.4)

The center of area of each universal element has to be located and its distance (X) from the bow recorded. The reference height (Href) at which its wind speed is quoted is usually specified by the client otherwise it is conventional to choose the meteorological reference height 10 meters. The main task is the estimation of the conversion factors:

$$\text{on the X-axis : } 1/2 \rho * A_x * U_x^2$$

$$\text{on the Y-axis : } 1/2 * A_y * U_y^2$$

Where  $A_x$  and  $A_y$  are respectively the projected areas of the superstructure normal to direction of force,  $U_x$  and  $U_y$  are respectively the longitudinal and lateral components of the effective wind speed ( $\bar{U}$ ) and ( $\rho$ ) is the air density.

For a ship at anchor, the uniform wind force coefficients were evaluated for head and side force in the form of:

$$C_f = F / (1/2 \rho U^2 * A_f) \text{ or } C_f = F / (1/2 \rho \bar{U}^2 * A_f) \text{ with } \bar{U} = \text{effective wind speed acting on the whole projected area } A_f.$$

For ships in motion, the user should strictly combine the vectorial  $\bar{U}_x$ ,  $\bar{U}_y$  (longitudinal and lateral components of  $\bar{U}$ ) separately with the velocity of motion  $V$  to provide individual conversion factors  $1/2 \rho \bar{R}_x^2 * A_x$  and  $1/2 \rho \bar{R}_y^2 * A_y$ .

Where the difference between  $U_x$  and  $U_y$  is small it is more convenient to combine an average value vectorial with  $V$  to provide an averaged value of  $1/2 \rho \bar{R}^2$  for combination with the areas  $A_x, A_y$  thereby implying a common wind angle.

From experience people have found that the calculated centre of pressure position  $X_o/L$  from the bow agree, within the uncertainty of estimation, with the measured ratio ( $C_{nbow}/C_y$ ) at  $\beta = 90$  degrees, where the yawing moment coefficient is defined as:

$$C_n = N / (1/2 \rho \bar{U}_y^2 A_y L) \text{ and the suffix (N) refers to the bow position of the moment axis (L=Ship's overall length).}$$

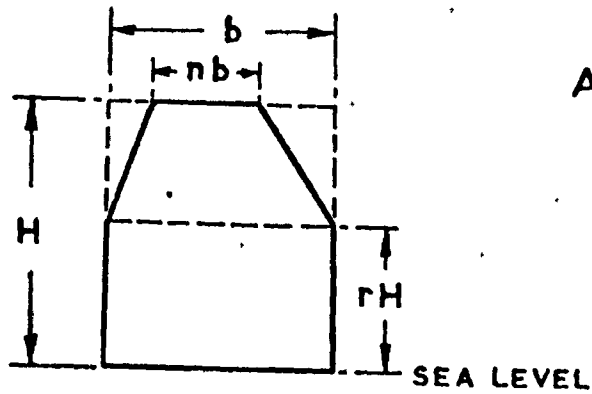

$$A\bar{U}^2 = bH \left\{ \frac{m}{m+2} \left[ 1 - \frac{r}{1-r} (1-n) \right] \left[ 1 - r^{\frac{m+2}{m}} \right] - \frac{m}{2(m+1)} \frac{(1-n)}{(1-r)} \left[ 1 - r^{\frac{2(m+1)}{m}} \right] \right\} U_H^2$$

WHERE  $\frac{U_h}{U_H} = \left(\frac{h}{H}\right)^{\frac{1}{m}}$

$m =$  Reciprocal of power law index for velocity profile

UNIVERSAL ELEMENT OF PROJECTED AREA

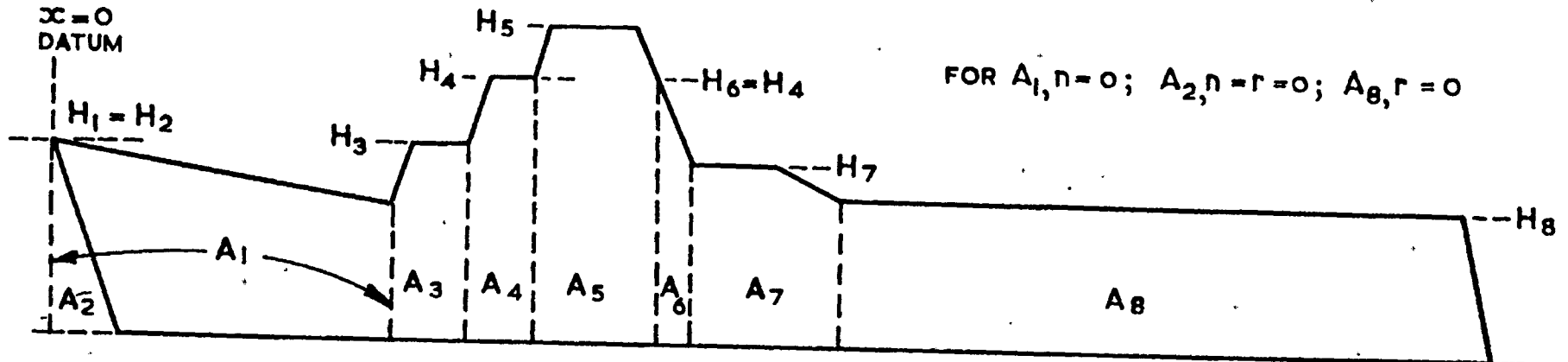

FOR  $A_1, n=0$ ;  $A_2, n=r=0$ ;  $A_8, r=0$

DIVISION OF LATERAL PROJECTION INTO UNIVERSAL ELEMENTS

FIG. 4 ESTIMATION OF VELOCITY-AREA PRODUCTS

The ahead force coefficient ( $C_x$ ), the side force coefficient ( $C_y$ ) and the differences  $X/L$  ahead of the effective centre of area position are given by the table 1 (See copy of table 1). The evaluation of ahead force( $X$ ), side force( $Y$ ) and the yawing moment( $Y.M.$ ) provides the wind forces and yawing moment on the superstructure for the condition considered and their expressions are:

$$X = C_x * (1/2 \rho \bar{R}_x^2 A_x)$$

$$Y = C_y * (1/2 \rho \bar{R}_y^2 A_y)$$

$$Y.M. = Y(\bar{X}/L - \bar{X}_0/L + \bar{X}_{ref}/L)$$

More details on those formulas will be given in the third part of my paper. [7]

### 3.1.3. Dynamic behavior in wind.

When the ratio of wind velocity to ship speed is large, wind has an appreciable effect on ship control. Even a moderate wind can make a ship advancing at slow speed difficult to control. To provide adequate control of ships in wind, it is necessary to develop information concerning wind effects on ship controllability under various situations. Effects of a given wind increase in a direct ratio to above water area, distance from the center of lateral area to the longitudinal center of gravity and aerodynamic drag coefficient. The low speed handling characteristics of some ships like automobile carriers, containerships and LNG-ships are critically influenced by wind because of their relative windage area due to high freeboard.

When the wind /ship velocity ratio is moderate, operation in such wind is possible, using the rudder to maintain a desired course. But, when this velocity ratio increases, stable course keeping may not be possible for wide ranges of wind. Therefore in order to maintain a predetermined straight course in moderate wind, some degree of rudder angle is required to counteract the aerodynamic and hydrodynamic forces and moments. When ship speed and heading, and wind velocity and direction are given, then the required rudder



TABLE 1 - WIND LOADING DATA FOR LISTED DESIGNS

Model	$A_y/A_x$	$2A_y/L^2$	$\theta^\circ$	0	10	20	30	40	50	60	70	80	90	100	110	120	130	140	150	160	170	180		
Cargo (A)	4.20	.162	Cx	.571	.580	.483	.467	.402	.421	.382	.207	.148	.105	.016	-.137	-.244	-.464	-.613	-.747	-.796	-.719	-.832		
			Cy	0	.199	.383	.592	.753	.873	.925	.982	.983	.968	.974	.972	.956	.887	.733	.610	.275	.128	0		
			$\bar{x}/L$		-.264	-.244	-.192	-.167	-.128	-.092	-.071	-.034	0	.026	.044	.069	.079	.087	.132	.172	.056			
Cargo (A)	3.64	.119	Cx	.578	.650	.632	.448	.386	.378	.484	.268	.122	.051	.004	-.183	-.356	-.565	-.719	-.803	-.824	-.747	-.854		
			Cy	0	.190	.386	.607	.814	.935	.948	1.011	1.010	.996	.995	.974	.935	.835	.660	.468	.263	.120	0		
			$\bar{x}/L$		-.264	-.196	-.184	-.160	-.111	-.057	-.047	-.019	0	.033	.047	.065	.068	.090	.147	.191	.234			
Cargo (A)	3.25	.097	Cx	.624	.665	.633	.592	.488	.329	.333	.289	.115	.075	-.040	-.190	-.416	-.622	-.799	-.874	-.904	-.819	-.890		
			Cy	0	.192	.375	.609	.832	.999	1.028	1.041	1.032	1.017	1.027	1.011	.958	.839	.665	.459	.253	.102	0		
			$\bar{x}/L$		-.240	-.170	-.165	-.127	-.107	-.062	-.043	-.042	0	.022	.034	.032	.054	.082	.118	.151	.253			
Cargo (B)	3.64	.119	Cx	.636	.655	.594	.473	.341	.238	.196	.172	.186	.087	-.054	-.209	-.359	-.573	-.732	-.824	-.803	-.898	-.865		
			Cy	0	.174	.399	.607	.781	.890	.923	.922	.943	.953	.952	.910	.890	.788	.661	.433	.248	.100	0		
			$\bar{x}/L$		-.241	-.178	-.150	-.141	-.116	-.079	-.047	-.021	0	.025	.039	.056	.072	.088	.128	.199	.268			
Cargo (C)	3.64	.119	Cx	.691	.630	.583	.415	.341	.251	.199	.170	.147	.087	-.049	-.195	-.353	-.464	-.676	-.759	-.741	-.692	-.840		
			Cy	0	.166	.361	.569	.732	.814	.806	.820	.838	.846	.847	.815	.758	.694	.567	.412	.258	.112	0		
			$\bar{x}/L$		-.254	-.161	-.134	-.099	-.085	-.069	-.047	-.024	0	.003	.024	.047	.042	.065	.118	.167	.198			
Cargo (D)	3.64	.119	Cx	.738	.621	.583	.452	.363	.285	.228	.272	.243	.124	0	-.068	-.287	-.505	-.677	-.762	-.734	-.761	-.834		
			Cy	0	.182	.382	.579	.718	.811	.884	.870	.878	.876	.886	.864	.842	.760	.601	.435	.247	.100	0		
			$\bar{x}/L$		-.185	-.134	-.100	-.101	-.075	-.074	-.046	-.023	0	.005	.051	.057	.067	.084	.132	.185	.252			
Cargo (E)	3.22	.144	Cy	.557	.562	.488	.299	.193	.166	.291	.235	.243	.153	.056	-.044	-.264	-.407	-.515	-.592	-.671	-.693	-.808		
			Cx	0	.193	.368	.526	.604	.708	.782	.812	.845	.851	.854	.833	.809	.746	.614	.443	.249	.113	0		
			$\bar{x}/L$		-.312	-.251	-.197	-.186	-.162	-.110	-.071	-.027	0	.014	.043	.050	.061	.076	.135	.199	.231			
Cargo (E)	3.04	.091	Cx	.606	.637	.534	.449	.219	.105	.279	.303	.213	.077	.001	-.128	-.328	-.511	-.638	-.649	-.728	-.744	-.883		
			Cy	0	.204	.385	.557	.742	.884	.814	.805	.829	.862	.856	.827	.794	.682	.541	.361	.199	.081	0		
			$\bar{x}/L$		-.303	-.212	-.165	-.146	-.108	-.080	-.034	-.004	0	.027	.031	.046	.067	.091	.127	.206	.112			
Container (A) (deck clear)	5.75	.145	Cx	.607	.640	.610	.514	.290	.055	-.089	-.260	-.340	-.351	-.390	-.390	-.318	-.445	-.555	-.607	-.580	-.605	-.670		
			Cy	0	.169	.355	.558	.725	.852	.938	.986	1.013	1.017	.997	.965	.924	.840	.705	.525	.310	.143	0		
			$\bar{x}/L$		-.235	-.202	-.170	-.143	-.118	-.094	-.061	-.030	0	.029	.054	.064	.065	.074	.112	.170	.232			
Container (A) (deck full)	6.28	.145	Cx	.611	.620	.850	.912	.720	.390	.120	-.190	-.400	-.490	-.480	-.452	-.435	-.520	-.515	-.645	-.760	-.725	-.664		
			Cy	0	.160	.140	.543	.780	.920	1.014	1.045	1.070	1.094	1.090	1.080	1.068	.920	.740	.516	.292	.143	0		
			$\bar{x}/L$		-.295	-.224	-.170	-.140	-.124	-.089	-.060	-.031	0	.030	.056	.070	.083	.108	.143	.150	.152			

Cont'd

angle can be determined to produce the necessary sideslip of the ship for a straight course, (See graph of Fig.5). The figure shows that for a given wind-to-ship velocity ratio greater rudder angles are required when the wind is from the beam. Since the maximum rudder angle of many ships is limited to 35 degrees, the ship will not be generally controllable in a wind that requires a rudder angle close to this limit. [20]

### 3.2.WEATHER ROUTEING ELEMENTS.

Weather routeing is an application of oceanographical and meteorological information to produce a forecast for favorable route for ocean crossing by vessels. The master of a ship is ideally the best person to choose the route that his ship will follow, if weather conditions have no influence on the situation. However, for many centuries ships have moved under the forces of the environment alone and today the master is still obliged to take careful note of weather. In the practical ship weather routeing actual (observed and analysed) and predicted environmental data are used, and the effectiveness of weather routeing largely depends on the accuracy of the forecast data.

In the 1960's routeing services were established in many countries but prior to these navigators had depended on seasonal mean tracks and followed climatological routes.

#### 3.2.1. The Objectives of ship routeing.

The objectives of ship routeing may be expressed as follows:

- time saving,
- fuel saving,
- minimising storm damage to the ship and cargo,
- attaining punctuality, to maintain schedule,
- meeting special requirements of the

individual voyage.

One of the prime objectives of weather routing is to avoid encounters with the following:

- heavy head seas,
- shipping of water on deck,
- slamming, heavy rollings.

All of them are the main causes of shipboard and cargo damages. Therefore, weather routing is widely used in the ocean navigation all over the world, at all times of the year.

As illustration to the need of weather routing, following example can be given:

It has been calculated that, when a medium size ship is operating in head seas in the region of 5 metres or more (wave height), the potential damage repair costs proportional increase for each one metre increase in sea height. The hull structure and propelling machinery is liable to suffer damage due to vibration and propeller racing seriously affect the vessel's speed. Knowing the weather ahead together with vessel's performance speed curves, it is possible with some accuracy to provide an updated ETA at any time during the voyage.

### 3.2.2. The Method used for Weather Routing.

The ship's response to various wave fields is determined by extracting sufficient data from the ship's deck log book to construct a performance curve (See fig.6). The wind and wave fields must be predicted for as far ahead as possible; at present this is about 72 hours. All the data are subjected to rigorous quality control by the computer, and are used to produce machine analyses of fields of temperature, humidity, winds and contour heights of pressure levels over the whole of the globe. A forecast for the next 72 hours is then computed using the meteorological office forecast level. These forecast winds are used to determine a sea wave forecast model.

Fig. 6 Ship performance curve graph.

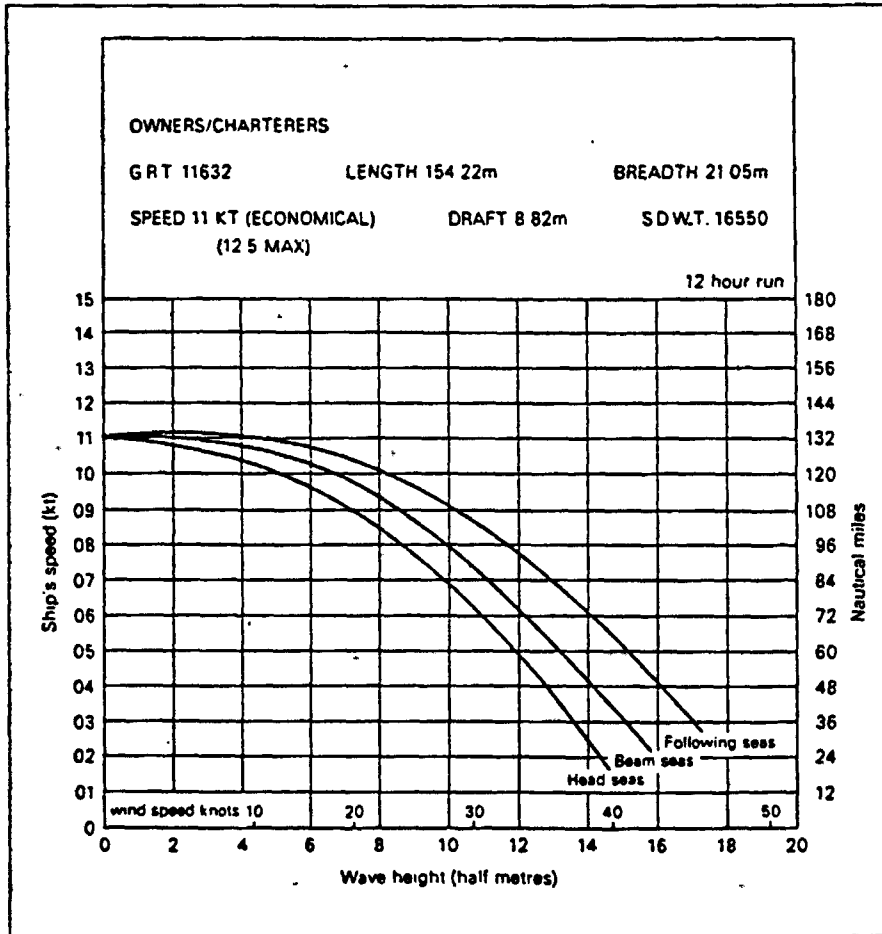

The forecast wave height and direction is then applied to the ship performance curve to determine how far the vessel will travel in the next 12 hours over a number of possible courses. These points are then joined to form a time-front. From selected points on this time-front the process is then repeated in successive 12 hour steps and results in a least-time track for that part of the route, which would normally be the course that the vessel would be advised to follow (See fig.7).

At this stage, subjective consideration must be given to other parameters. The router has to consider if the course is navigationally feasible, if the state of loading makes the heading inadvisable, if the time thus gained would be lost through adverse ocean currents and if the course would take the vessel into an area of fog or ice. A message is then sent to the master advising him to follow the selected route, and includes a forecast of wind force and sea direction and height along the route. This routine is continued daily throughout the passage and the surveillance of the ship's progress is achieved by plotting its position on successive six hourly weather charts.

The value of ship routeing advice depends in the first place on the existence of adverse weather conditions and secondly on whether such conditions can be avoided. The potential economic benefits such as the saving of fuel costs and heavy weather damage can be realized only if conditions along the shortest route are adverse and there is a choice of a more favorable route. [21]

### 3.2.3. Classification of Routeing.

Taking into account seasonal climate fluctuation and weather changes, the following classification may be suggested:

- climatic routes;
- strategic routes; and
- tactical routes .

Fig. 7.

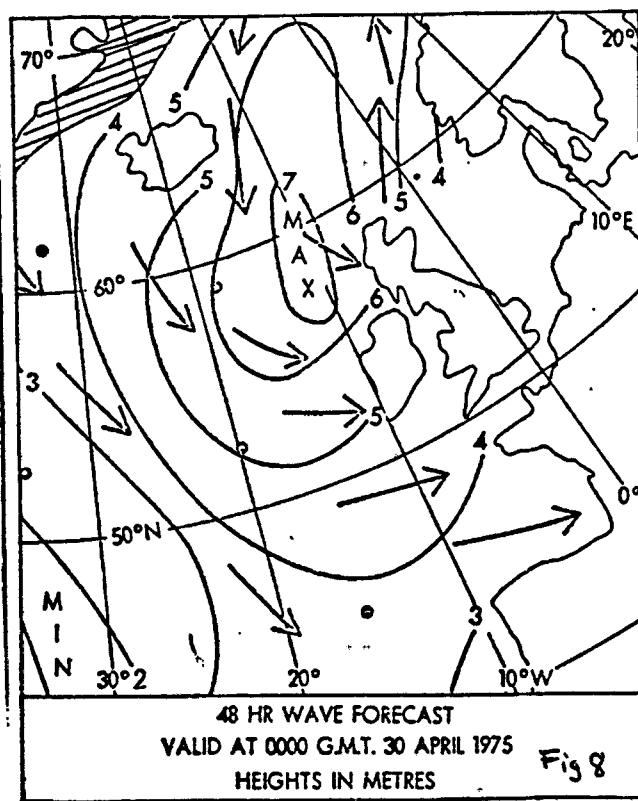
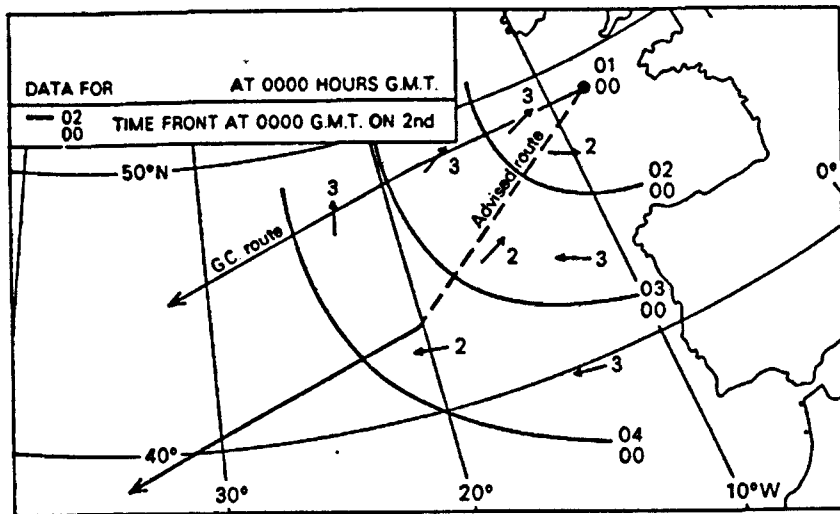

### 3.2.3.1. Climatic routes.

In middle latitudes, routes are advised on seasonal basis. For a particular season the historical routes are based on statistical past data concerning winds, current and other meteorological and hydrographical information. Such traditional routes are described in monthly pilot charts or presented in Ocean Passages for the world. The general information about the track chosen concerns the following:

- the mean depression tend to track;
- a mean position of the high pressure in the oceanic regions;
- favorable current data;
- the extensions and ice limits.

Climatological oceanic routes heavily depends on real winds and waves conditions existing during the period over which the passage is to be planned.

### 3.2.3.2. Strategic routes.

Some passages may have special requirements. These concerned the criteria or limitation. Fuel economy or damage avoidance may be considered. Such routes are planned for that special passages and have been termed as strategical routes. Method of routeing is based on weather analysis. The long period forecast and some idea of further outlook are taken into consideration. Also seasonal weather probabilities are analysed.

### 3.2.3.3. Tactical routes.

According to developments of the synoptic situation the time of departure is established. Such method is described as tactical routeing. The short term forecast (12-24 hours) are analysed. Weather maps concerning wave height and wind direction are considered, gale warning are taken into account.

#### 3.2.4. Regions of Weather routeing.

There are five main areas where weather routeing may be of benefit to the master in ocean navigation and which are:

- the North-Atlantic Ocean;
- the North-Pacific Ocean;
- the South-Indian Ocean;
- the South-Atlantic Ocean; and
- the South-Pacific Ocean.

Weather condition in the ocean navigation north of 35 N and south of 40 S are such that the tactical ocean routes between point A and B in this area is very much dependent on the weather conditions existing during the passage. The weather becoming more accurate as better weather reports and forecast become available on board.



## CHAPTER 4. THE TECHNICAL ASPECT OF SAFE STOWAGE AND SECURING OF CARGO.

The safe stowage and securing of cargo units and vehicles on board ships, has a very high priority on the agenda of the Sub-Committee on Containers and Cargo within the IMO.

In 1980, the first draft resolution was prepared by the Sub-Committee, setting out guidelines for safe stowage and securing of cargo and other entities in non-containership. This resolution for the first time, addressed items such as:

- details for fixed securing arrangements and their locations (pad-eye, eye bolts, elephant feet, etc);
- location and stowage of portable securing gear;
- details of portable securing gear including an inventory of items provided and their strength;
- correct application of portable securing gear on various cargo units, vehicles and other entities carried on the ship; and indication of the variation of transverse, longitudinal and vertical accelerations to be expected in various positions on board the ship.

Some administrations have published general recommendations and guidelines for the securing of cargo on board ships. No rules have, as far as known, been established.

When it comes to securing of general cargo and cargo units on board ships, up to now very few rules and recommendations have been published. Some classification societies: Lloyd's Register of Shipping (LR), Germanischer Lloyd (GL), Bureau Veritas (BV) and Det Norske Veritas (DNV) have developed regulations for containers securing arrangements. Within these rules, formulae for calculations of the vertical, transverse and longitudinal accelerations have been established.

The analysis of all these different approaches points out the need of an internationally agreed method for

the examination of non-standardized stowage and securing arrangements. An appropriated proposal of such a method is presented consisting of:

- system of basic data plus correction factors for attaining assumptions of external forces;
- recommendations for the assessment of strength of securing material and securing devices including the establishment of an individual safety factor;
- balance of forces and moments for the final examination of suitability.

What I intend to do in this chapter, is first to analyse the different criteria for estimating the risk of cargo shifting, to describe the proper stowage needed, the securing of cargo under special conditions and finally give an approach of cargo securing calculations.

#### 4.1. CRITERIA FOR ESTIMATING THE RISK OF CARGO SHIFTING.

When estimating the risk of cargo shifting, the following should be considered:

##### 4.1.1. The dimensional and physical properties of the cargo.

A good information on the size, the shape and the weight of the cargo will serve as a guide for identification of a typical stowage and securing problems. For instance, steel coils, wire rods which are some heavy units (20-25 tons) are not easy to handle regarding the securing. The rolling cargoes subdivided into two categories (vehicles representing themselves as cargo and vehicles which carry the actual cargo) can be heavy with a high center of gravity (the second category) and they can be a problem for the securing techniques, considering size, weight and their uniformity. Some cargoes have a tendency to deform or compact themselves during the voyage which will result in a slacking of their securing gear.

#### 4.1.2. The location of stowage on board.

\* When considering the location for stowing a heavy cargo item, the typical distribution of accelerations on the ship should be kept in mind:

- .1 lower accelerations occur in the midship sections and below the weather deck;
- .2 higher accelerations occur in the end sections and above the weather deck.

\* When heavy items are to be stowed on deck, the expected weather side of the particular voyage should be taken into account.

\* Heavy items should preferably be stowed in the fore-and-aft direction.

#### 4.1.3. The suitability of the ship for particular cargo.

It is the case of modern multi-purpose ships with generally one tweendeck of considerable height and high lower holds, thus resulting in high stowage blocks with considerable stacking pressure and sometimes difficult for cargo securing. The barge carriers transport general cargo and break bulk which are stowed in barges in a conventional manner. The barges have sufficient volume to permit dangerous shifting of cargo inside when not all the space has been filled (with cargo of large specific weight). The bulk carriers which have been designed for the carriage of dry bulk cargo in the first place, are sometimes used for the shipment of other goods. Also the inevitable spaces between cargo units on Ro/Ro ships, support the so-called "domino-effect" if the securing of one unit fails.

#### 4.1.4. The suitability of the securing arrangements for particular cargo.

On the modern multi-purpose ships, sometimes we can have poor equipment with respect to lashing eyes on deck and in the hatch. It is also the case for the barge carriers

which are poorly equipped with lashing points in the barges and bulk carriers which have no lashing eyes in the holds.

#### 4.1.5. The expected weather and sea condition.

Taking into account first seasonal climate fluctuation and weather changes for the different routeing classification (climatic routes, strategic routes and tactical routes) and finally the different regions of weather routeing (See paragraphs 3 and 4 of the previous chapter).

#### 4.1.6. The expected ship behavior during the intended voyage.

Ships behave differently in a seaway, depending on size, hull, speed, mass distribution and etc. In some cases, shipowners ask for a ship design with limited motion accelerations. For instance, the barge carriers have to be operated with large GM-values which leads to poor sea behavior, and consequently to considerable stress in cargo securing devices.

These criteria should be taken into account when selecting suitable stowage and securing methods and whenever reviewing the forces to be resisted by the securing equipment.

Besides these criteria, the master should accept the cargo on board his ship only if he is satisfied that it can be safely transported. [12];[22]

### 4.2. REDUCTION OF SOME RISKS THROUGH PROPER STOWAGE.

#### 4.2.1. General Elements to be considered by the Master.

Having evaluated the risks of cargo shifting, by taking into account the criteria set out in the previous paragraph of this chapter 2, the master should ensure prior to loading any cargo, cargo unit, or vehicle that:

- the deck area intended for its stowage is as far as practicable, dry and free from oil and grease;
- the cargo, cargo unit or vehicle appears to be in

good condition suitable for transport by sea, and can be effectively secured;

- all necessary cargo securing equipment is on board and in good working condition;
- cargo in or on cargo units and vehicle is to the extent practicable, properly stowed and secured to the unit or vehicle.

#### 4.2.2. Cargo Information.

Before accepting a cargo for shipment, the shipowner or the ship operator should obtain all necessary information about the cargo and ensure that:

- the different commodities to be carried are compatible or suitably segregated;
- the cargo is suitable for the ship;
- the ship is suitable for the cargo ;
- the cargo can be safely stowed and secured on board the ship and transported under all expected conditions of the intended voyage.

The master should be provided with adequate information in advance regarding the cargo to be carried so that its stowage may be properly planned for handling and transport; (Annex to the draft of the Code on Safe Stowage and Securing of Cargo).

#### 4.2.3. Cargo Distribution.

Some cargoes as I already pointed out in the previous paragraph ( paragraph on estimating of shifting risks), have a tendency to deform or compact themselves during the voyage, while some with low friction coefficient, when stowed without proper friction increasing devices such as dunnage, soft boards, etc, are difficult to secure unless tightly stowed across the ship. These measures are needed to prevent cargo movements during the voyage such as:

- sliding and tipping, which are respectively lateral and rotational movement of the cargo, constitute its

major behavior;

- racking which is a deformation of cargo;

- collapsing which is a total breakdown of cargo, etc.

The ability of a vessel to return to the upright is dependent upon the resultant forces within the vessel (center of gravity), and those outside the vessel, the buoyant forces of the water. The position of the center of gravity is affected by the disposition of the cargo within the vessel, as well as by the condition of fuel, ballast and fresh water tanks. It is important that these have to be so arranged and organized that the vessel remains in a stable condition throughout the voyage.

Therefore, it is of utmost importance that the master takes great care in planning and supervising the stowage and securing of cargoes in order to prevent cargo sliding, tipping, racking, collapsing, and etc, during the voyage.

The cargo should be distributed so as to ensure that the stability of the ship throughout the entire voyage remains within acceptable limits so that the hazards of excessive accelerations are reduced as far as practicable.

Cargo distribution should be such that the structural strength of the ship is not adversely affected. Distribution of cargo can induce unacceptable bending moments, sheering forces and torque particularly in larger vessels.

This cargo distribution can be achieved through three different stowage methods:

- the single stowage, where the cargo which does not touch any side of the ship, is standing free and should be fully secured with full transversal securing to both sides;

- the side stowage, where one side is secured by the ship side wall, while the other side is free and must be secured fully (full transversal securing to one side); and

- finally the cross stowage which is a combination of both (single and side stowage) and gives an efficient holding together of the stow.

#### 4.2.4. The Use of Friction Forces for Cargo Securing.

The deployment of friction forces for cargo securing is common standard to keep the cargo under dynamic loads aboard the ship in place. Friction forces act in the direction of the sliding surface and depend on the vertical pressure force between both sliding areas and on their surface roughness. The formula for the friction force (assuming as a linear relationship) is expressed as follows:

$$R = \mu * N$$

R = friction force;

N = normal force (normal to sliding area)

$\mu$  = friction coefficient.

From this formula, we can conclude that:

- the friction force depends on the magnitude of the pressure force (N) normal to the contacting surfaces;

- the friction force depends on the coefficient ( $\mu$ ) which is governed by the materials, their surface structure and the state of motion between the two contacting areas, i.e. no motion or sliding.

##### 4.2.4.1. Friction Coefficient ( $\mu$ ).

The friction coefficient is usually taken as a property of the two contacting materials. The smallest friction coefficients are for surfaces steel-steel (less than 0.2), the largest for rubber-wood (up to 0.8) and with metal-wood somewhere in between, (See fig.5.1). With surfaces such as steel-steel, the friction coefficient is very small and in cargo securing such surfaces have to be avoided in order to increase the friction coefficient. This is achieved by attaching or putting other material with larger friction coefficient (e.g. wood), in between the contacting surfaces of deck and cargo. Due to the large "spectrum" of the friction coefficient, a considerable uncertainty comes in. Furthermore, grease and wetness reduce

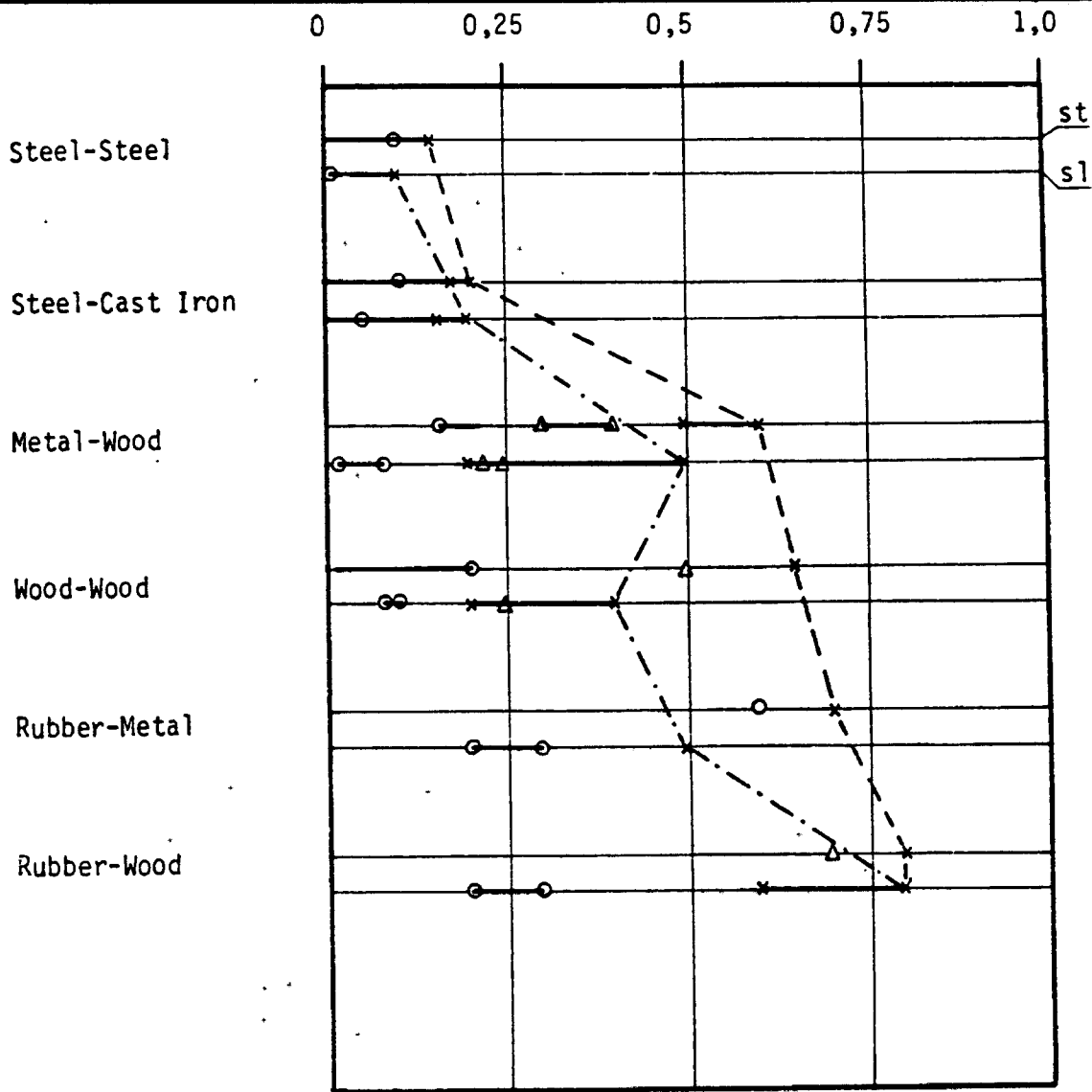

x dry  
o greased  
Δ wet

Upper Limit:

static: 0,15 ..... 0,80  
sliding: 0,10 ..... 0,80.

Fig. 5.1:

Graph of Friction Coefficients

(values taken from IMO BC 25/7/5/Add.1,  
13 January 1984, Mariterm AB)



the friction coefficient (down to about one third). The values given for the friction coefficient in the most of tables, which are used for application in lashing calculations, and they show the wide spectrum of data. It might be advisable to check:

- how friction coefficients have been derived;
- how the different surface roughness found in practice has been included.
- what spectrum must be taken into account to be sure on the data for calculation;
- how the friction coefficients are affected by ship motions, and vibrations from the main ship propulsion, or slamming impacts;
- what effect friction forces have on different cargo units, such as e.g. road vehicles, against packed goods.

#### 4.2.4.2. Force Normal to Friction Surface.

According to the mathematical expression of the friction force  $(R) = \mu * N$ , it is a common practice to increase the value of the force normal to the contacting frictional surfaces to help cargo securing. A certain force is already given by the weight of the cargo resting on the deck. By lashing the cargo unit down to the deck surface, the normal force will be increased.

It is important to point out that, practically, lashing does not just press the cargo down to the deck surface, or transfer only normal forces from cargo to the ship structure, but lashing attacks the cargo unit at some angle in space, and only its vertical component to the deck comes in to assure friction. The fig 5.2 illustrates the lashing of a road vehicle. The lashing at angle  $(\alpha)$  to the deck is meant to fulfill two purposes:

- .1 prevention of parallel sliding;
- .2 prevention of overturning (around the point O1).

Assuming a friction coefficient rubber-wood of about 0.5, the

Sliding

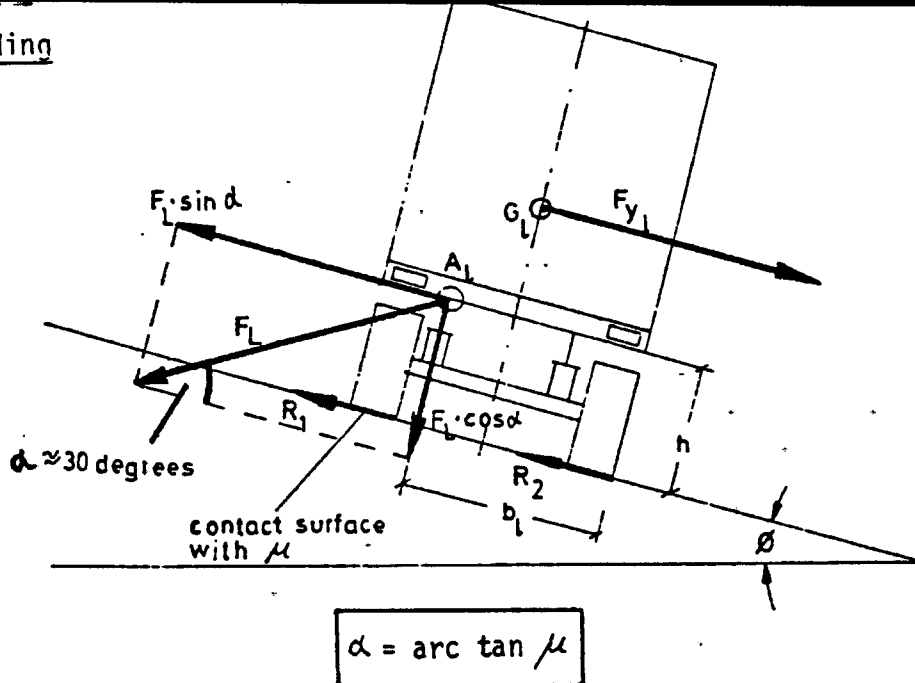

Case 2  
Overturning

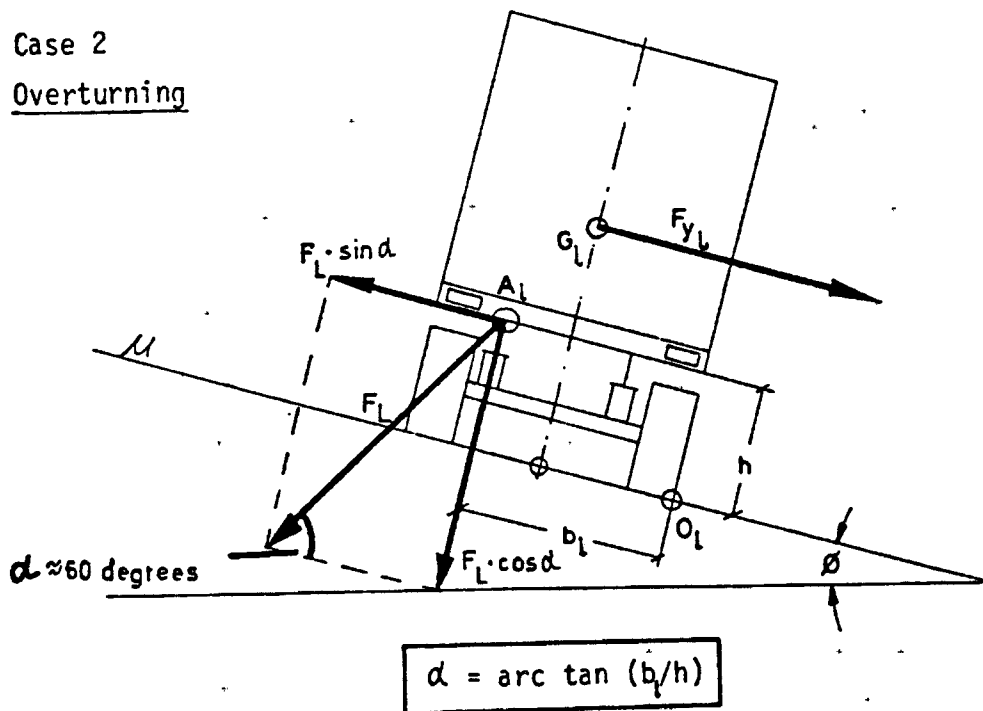

Fig. 5.2:

Different Angle of Lashing for Minimum Force against either Sliding or Overturning  
(compare with Fig. 5.3)

optimum angle of attack ( $\alpha$ ) against sliding is supposed to be around 30 degrees, but against overturning ( $\alpha$ ) is approximatively 60 degrees, (for more information see fig.5.3)

Some conclusions may be drawn from the given example:

- any required pressure force or angle of attack for lashing can only be based on the size, mass and on the geometry of a particular typical unit, and on the needed motion prevention of the cargo, such as sliding, either transverse or overturning;
- recommendations or requirements on lashing cannot be given in general, but relate very much to the particular cargo unit (type of cargo unit).

#### 4.2.4.3. Dynamic effects on friction forces.

Until now, the considerations above, have been based only on a static treatment of the problem, the time variation of the dynamic loads at sea has not been taken into account. However, acceleration forces vertical to the deck change considerably in time, depending on the ship motion. Accelerations can cause uplifting of the cargo at some point of the contacting surface between cargo and deck. Obviously, the force against sliding will then substantially be diminished. Also hull vibrations may cause reduction of the friction force. [12];[22]

#### 4.3. SECURING OF CARGO UNDER SPECIAL CONDITIONS.

Securing and lashing is a complimentary term relating to the use of cargo gear. To be sure that a cargo stow is safe it needs the application of a variety of safeguarding equipment according to its type, method of packaging and disposition in the ship.

Lashing and securing of cargo aboard general cargo vessels is as old as seafaring is. This kind of work was already necessary on the very first vessel that ever started

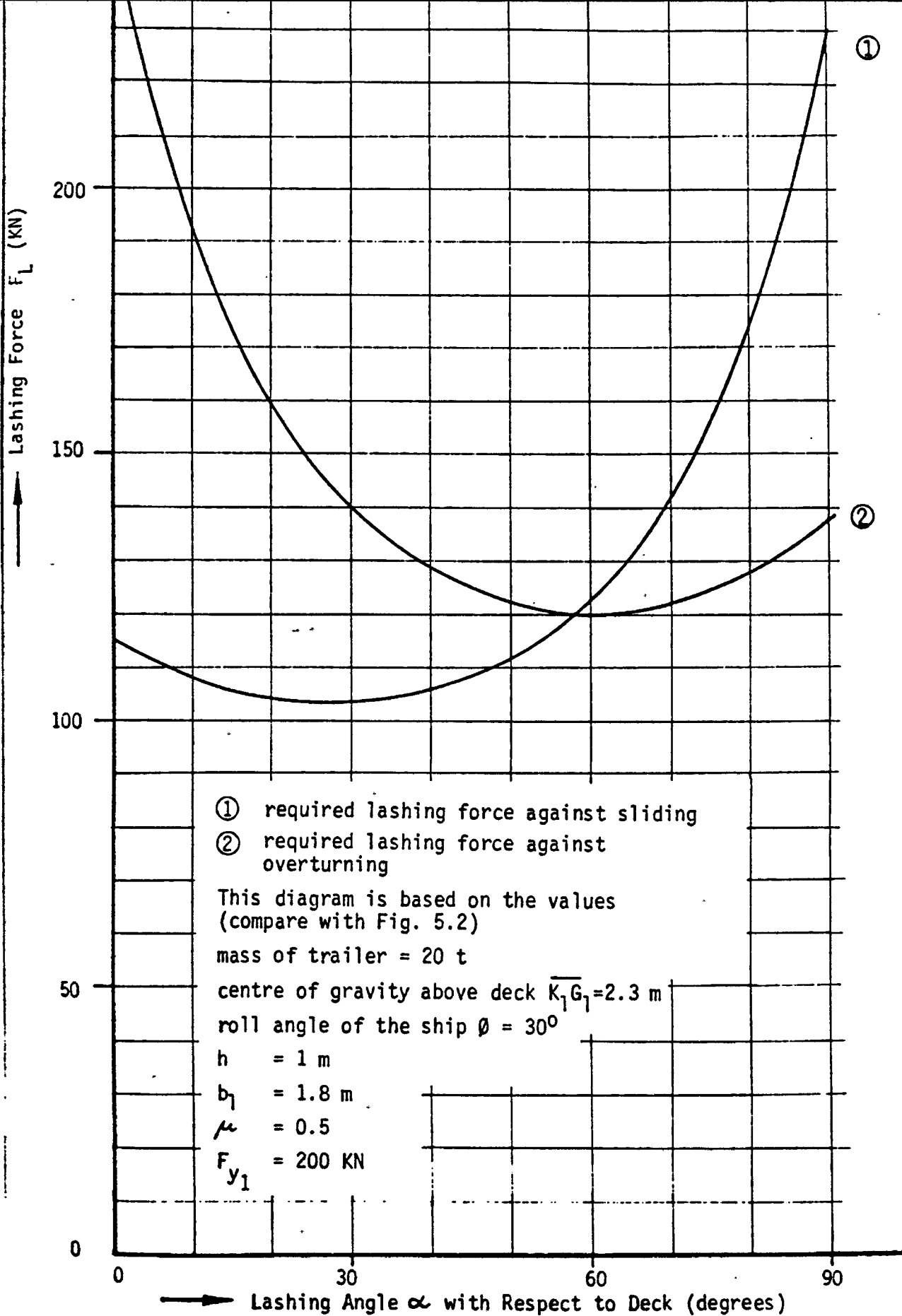

Fig. 5.3:

Required Lashing Force Versus Lashing Angle,  
 Compared for Sliding and Overturning of Trailer

to sail and lashing and securing of cargo was over the centuries a part of seamanship. The increase in size of the vessels, the reducing of crew and the great change in the kind and packing of cargo has brought forward an outstanding and complete change. Cargo securing has become a shore-based job. Additionally it must be taken into consideration, that the traditional knowledge and experience are partly worthless when thinking of the seatransport of full palletized cargoes, containers, construction parts, deck cargo and vehicles/trailers, which need a careful and safe securing more than cargo existing of bags, cases and drums. Nowadays, we can put these different kind of cargoes in three categories as follows:

- standardized cargoes such as : containers, rail wagons, shipborne barges etc;
- semi-standardized cargoes such as: road vehicles, automobiles, on RO/RO ship, trailers etc;
- non-standardized cargoes such as: portable tanks, tractors, buses(carried on a ship not designed and fitted for their transport), heavy cargo(such as locomotives, transformers), coiled metal sheet , heavy cargo items of metal products(such as bars, pipes, plates rods wire coils, etc), timber cargoes(such logs, packaged timber etc) and unit loads.

For the first and second categories of cargo a variety of forms of securing and lashing has been introduced and continues to be developed, while for the third category, there is not a uniform method.

#### **4.3.1. Standardized Securing System.**

##### **4.3.1.1. Securing of containers.**

Several of classification societies have published rules for container securing arrangements in both cellular and non-cellular ships.

All container lashing systems have some common aspects which can be summarized in two main finalities:

- to avoid the shifting of containers by means of foundations welded to the ship;
- to absorb the produced forces, which arise from the ship's motions, by means of rigid or flexible lashing devices or steel structures.

The containers are stowed on board generally in longitudinal direction, because the racking strength in transversal direction is greater than in longitudinal direction, and the greatest forces are thus produced by the rolling motion acting therefore in transversal direction.

The forces acting on the containers due to the ship's motions are absorbed by means of lashing rods, wires, chains or by more sophisticated elements and structure, as we shall see in this paragraph.

There are four well-known container lashing systems (the conventional system, the combined twistlock/conventional system, the transversal lashing system and the cellular system).

#### \* The Conventional System.

During the first years of container transportation, most of the vessels were not properly conditioned for container cargo, since they were designed to carry general cargo. Only on few vessels some preparations had been made in order to guarantee a safe container cargo, especially by welding of base foundations and hull structure reinforcement so as to support point loads transmitted to the ship through the corner fittings. Containers were transversely connected by double stackers between tiers and bridge fittings on top of upper tiers. The lashing was made of steel rods, wires or chains diagonally arranged with tensioners welding lashing eyes onto deck (See fig.).

The lashing cables of 20 to 36 tons breaking load and chains of 20 tons breaking load were standardized as securing devices, with their corresponding tensioners. The lashing and

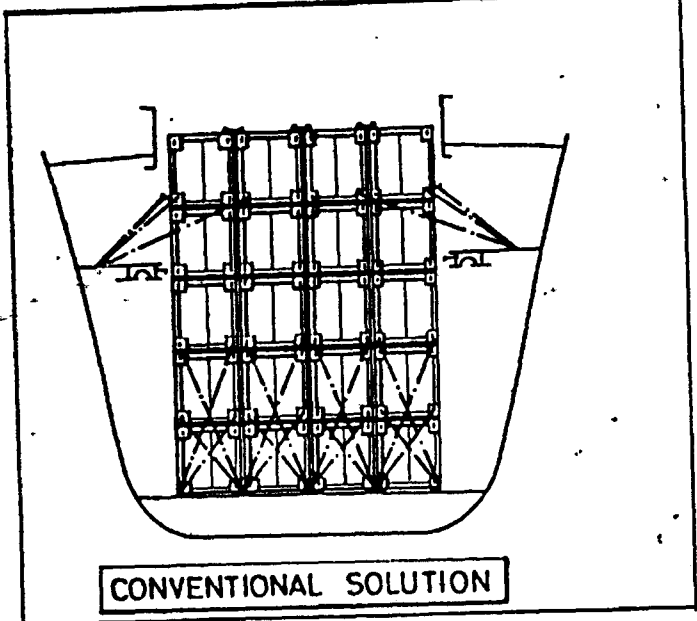
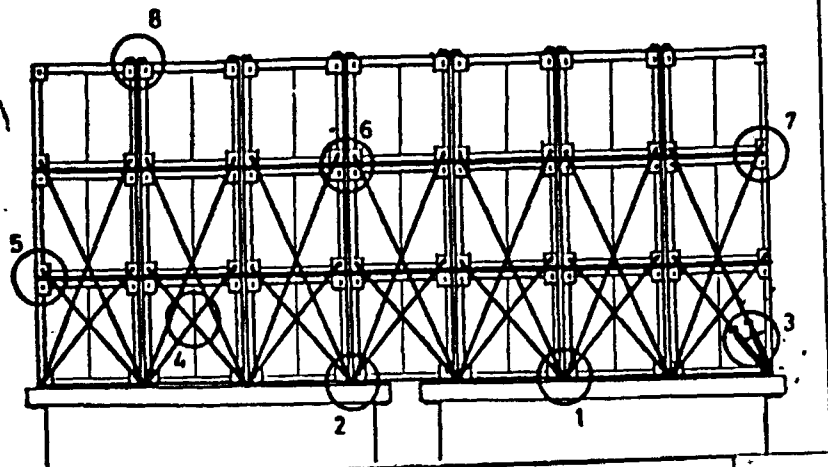

**TWISTLOCK SYSTEM**

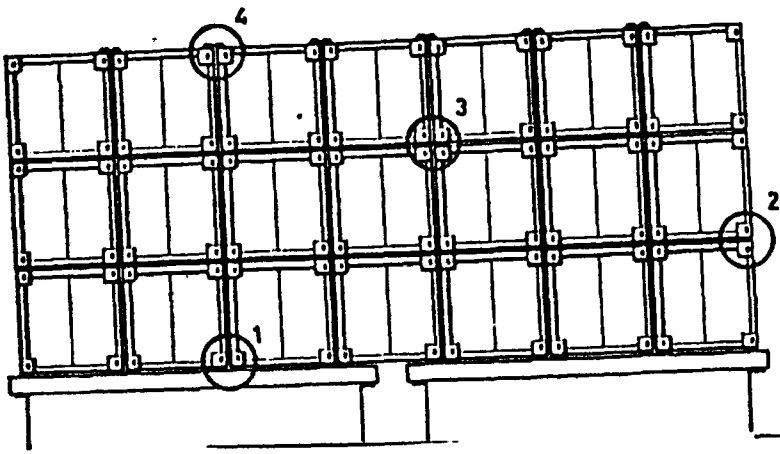

securing of containers in holds of cargo liners was specially complicated due to the number of stowed tiers (4 to 5 in some cases) and the length of cables or bars used, which in most of the situations were difficult to fit. Reductions in weight of loaded containers had to be considered due to the impossibility of absorbing all forces without overpassing the racking on containers with these lashings. Further, due to space limitations, lashing had to be arranged almost vertically, which represents not at all an ideal lashing. Consequently, the disadvantages of the system against other more sophisticated are clear and can be listed as follows:

- High cost of equipment due to big quantities of lashings in respect to the number of carried containers;
- Reduction in weights, specially in holds;
- Long lashing time for the containers and difficult access in fitting the lashing devices;
- Large number of different loose fittings.

\* The Combined Twistlock/Conventional System.

The introduction of the twistlock in the field of the container lashing system was one of the most important innovations in this field. As sophisticated intermediate stacking cone, the twistlock, allows the vertical connection between two containers, avoiding the rising movements of the container or stack. Further, this element allows the fitting of two containers coupled together at the same time during loading/unloading process, thus saving considerable time. Container stacks stowed with twistlocks are in principle independent stacks, which means that some type of forces as those produced by the wind, which in case of interbridged stacks would be absorbed by all the containers abreast, now are absorbed by the outer stack only, the inner stacks are free from the action of the wind. However, when necessary, the stacks can transversely be connected by linkage plates fitted onto the twistlocks once in position on the lower



containers. This allows twistlocks to work as double stackers transmitting the forces evenly through all the stacks placed side by side.

The use of twistlocks in combination with conventional systems presents important advantages:

- it allows a great reduction of lashings with subsequent economical savings;
- the lashing of containers is easier and quicker thus economizing stevedoring time;
- it should also be observed that on the upper deck, under certain conditions approximately 60 tons/stacks of 20 feet containers with only twistlocks can be loaded(See fig.).

\* The Transversal Lashing System.

Together with the creation and quick expansion of multi-purpose vessels, around 1975, for bulk, general cargo, even crude and in addition containers, a new lashing system was developed. The transversal system which solves a lot of lashing problems when used in certain types of vessels. The principle of this system is to transmit all horizontal forces owed to the ship's motions to the hull structure, which is accordingly reinforced. The transmission of forces is realized by connecting the containers transversely by means of double intermediate stacking cones or twistlocks with linking plates, obtaining a solid block. Then, and taking into account the magnitude of the acting forces, a suitable transversal element transmits the forces to the ship's structure, collocated to avoid, that the forces acting on the corner fittings exceed the maximum admissible value. Depending on the number of tiers and stacks stowed abreast, as well as on the available resistance of supports in the ship's structure, the arrangements of the transversal elements may differ, in order to obtain the most suitable distribution of forces.

When two tension-pressure transversal elements are placed at

the same level, one in front of the other, in each side of the block, the force transmitted by the container block to the ship's structure at this level is splitted in half in such way that each element will absorb only half of this whole force.

The advantages of the system are:

- a great reduction of the quantity of both fixed and mobile equipment, since it allows in most cases, the suppression of all diagonal and vertical lashings (up to 50% of saving in cost in comparison to the conventional system);
- furthermore it allows the loading of bigger stack weights;
- no difficulties for positioning of lashings for the upper tiers;
- it allows a greater standardization of equipment reducing the number of different types of fittings and 6 tiers of containers in holds can be safely loaded (See fig.).

\* The Cellular System.

The cellular system is based on the transmission of the forces acting on containers to the hull by means of a steel structure consisting of vertical profiles, generally steel angles, which are placed in the four corners of the containers and keep them in position. The used profiles are generally of 120x120x13 mm and are furnished with top funnels of moulded steel in order to facilitate the entry of containers. The lower ends are usually fitted with doubling plates in order to reinforce the container supporting area and fixed to the tank top by welded or screwed on bolts. The vertical guides are transversely connected by horizontal beams which are to resist the transversal forces acting on containers and transmit them to the ship sides. These horizontal beams are to be placed, whenever possible at the container corner fitting level, in order to absorb the

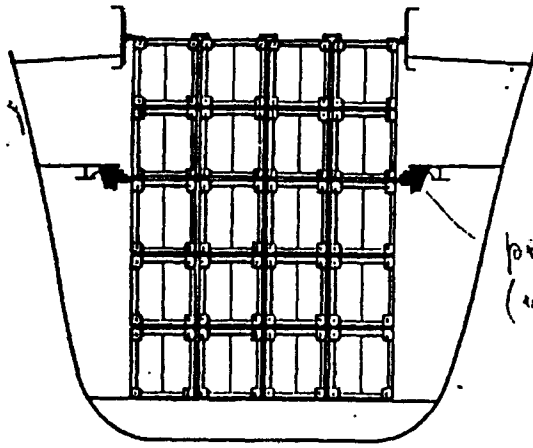

pressure-tension element  
(use of linkage plate)

TRANSVERSAL SOLUTION

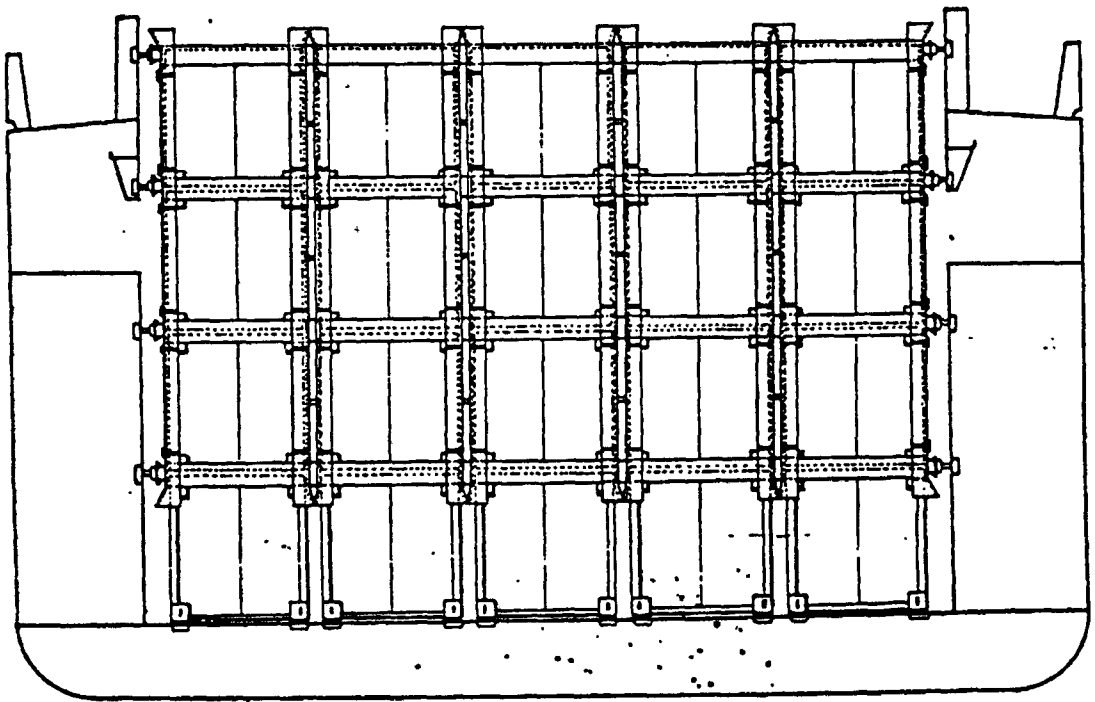

DEMOUNTABLE CELL GUIDE SYSTEM

transversal forces without inducing pernicious bending moments in the vertical guides. The longitudinal forces due to pitching motions are to be absorbed either by the athwartships beams, provided that they have enough strength, or by longitudinal tubes connecting the transversal beams with the transversal bulkheads of each hold. The forces transmitted by these longitudinal elements to the ship or to the transversal end beams are considerably lower than the transversal forces, because the longitudinal accelerations of pitching are smaller than the rolling acceleration, and at the other hand, the number of rows of containers in one hold is inferior to the number of stacks placed athwartships.

This system gives a great deal of advantages such as:

- alternative loading of containers of different length (40' and 20') in the same hold by installing fixed cells for 40'- containers with a removable panel in the middle for 20'- containers which has to be connected to the ends of the 40' guides;
- it represents the quickest and most practical way of container securing, since it eliminates completely the use of loose fittings and requires nobody in holds for lashing;
- for the guides which are demountable, the mounting operation requires a maximum of 8 hours with a team of 8 men aided by an auxiliary crane;
- the main characteristic of the system is the versatility. [19]

#### 4.3.1.2. Securing of seaborne barges.

The barges are secured by means of screw-lashing assemblies on the upper deck, while pneumatically operated screw jacks are lowered from the deck head on the main and lower deck levels to hold the barges securely during transit. Two rows of lashing rings are fitted around the barge deck itself for securing cargo. Between these rows, a row of combined cargo lashing cleats and pedestal sockets is fitted.

Portable pedestals are fitted in these sockets to support up to ten 30-ft containers.

#### **4.3.2. Semi-Standardized Stowage And Securing.**

##### **4.3.2.1. Securing of road vehicles and automobiles.**

Road vehicles of different kinds are shipped in an increasing number at sea, on short trades as well as on long international voyages. So far, for example, cargo-carrying vehicles with or without driver are shipped over the North Sea and the Channel. A big number of brand new vehicles such as cars, trucks, buses are also transported on sea. On board the first RO/RO ship, traditional lashing systems such as point lines tensioned with a timber pin, the so called Spanish windlass, were employed for road vehicles securing. Gradually the lashings are made of chain or a material of equivalent strength(wire), with a tension regulating device or a rigging screw. Their minimum strength without permanent deformation is not less than 120 kN. The lashing ends are fitted with hooks or any other devices designed in such way that they cannot come apart from the lashing points on the ship or tie down on the vehicle when the latter is exposed to the various stresses of the voyage. Cars are secured by means of four plastified cable tensioners of about 1000 kgs breaking load provided with two hooks, fitting to the lower structure of the cars and into the fixed foundations welded on deck respectively. Some pure car-carrier vessels have adopted a system consisting of chains distributed in longitudinal and transversal direction welded onto the deck in such way, that wherever a car is stowed a lot of lashing points are available avoiding thus any other fixed elements. The advantage of this system consists in the flexibility to secure any type of non standardized cargo.

##### **4.3.2.2. Securing of trailers and mafis.**

\* Securing of trailers and semi-trailers.

Securing of trailers could be divided into two areas: the securing of the goods on the trailer, and the securing of the trailer itself on board the ship. The shipowner can influence the second area only on which the emphasis in this section will also be put. Trailers are stowed in the fore and aft direction of the vessel forming longitudinal lanes, fixed flush foundations are distributed all along them. These flush foundations, specially designed to fit chain accessories called elephant feet, are usually about 3 meters distance from the adjacent, thus allowing the lashing of trailers of 6 and 12 metres long. The trailers are secured by use of trestle support with fixed height (1.25m) for the front side and two vertical adjustable supports for the rear part, which shall protect the trailer from the cyclinal forces which may occur due to the effect of the ship's motions on the suspension system of the trailer. Further the ensemble is secured to the fixed foundations by a number of lashing devices usually 11 or 13 mm diameter long link chains of 15/22 tons breaking loads respectively varying from 4 to 8 chain assemblies per trailer. Chain hook up units, chain turnbuckles or pneumatic tensioners allow to tighten the lashings correctly. Another system, developed in recent years, to reduce the handling time is the so called Roloc-box, which is used on the US West-Coast, but can not be used together with roll trailers. For additional precaution and to avoid unexpected rolling displacement of the cargo, wooden or rubber wheel chocks should be placed under, at least one wheel at each side. [2];[19]

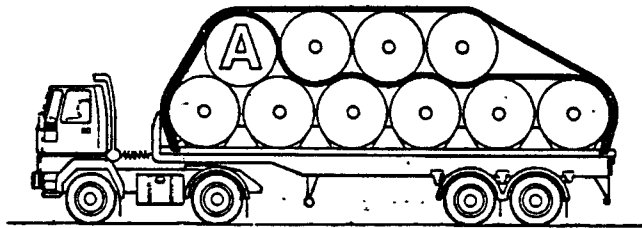

A tarpaulin sheet is normally added to assist with lateral restraint and give weather protection. - see FIG 5

FIG. 4

FIG. 5

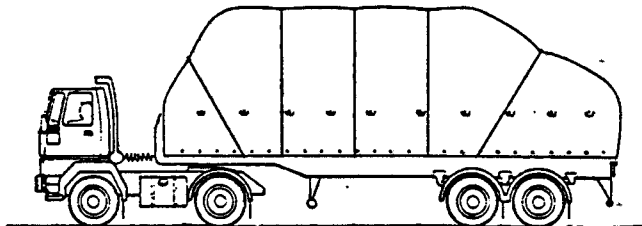

#### \* Securing of Mafis.

The so called mafis are low rolling platforms of about 75cm height which are moved by means of special trucks provided with so called goose necks. These platforms do not require any trestles or supports, but only frontal lashing chain fitted to the lower corner of the upper container (in case being two containers high carried), or to the upper corners of the first tier (case of only one). In case two containers high are placed on the mafi trailer, lashing chains should be preferably arranged from deck to the lower corner of the upper container, in order to avoid an excessive instability factor of the total loaded unit. Twistlocks between lower and upper corner should be provided to form a more rigid block. In the case of other cargo e.g. machinery, the load should be restrained against forward, backward and sideways movement by chain, steel wire or webbing lashings attached to anchorage points on the mafis. All lashings should incorporate some form of tensioning device.

#### 4.3.3. Securing of Non-standardized units.

As these cargoes can consist of any commodity in any shape or form, only general common sense recommendations can be given. The basic aim is to secure the cargo to prevent any movement in any direction, to avoid damage to cargo or ship. The methods used have been: lashing, bracing or combination of these. Corner protectors are used to protect goods as well as lashing equipment. Bracing is accomplished with timber or air cushions. The idea is to fill the voids in between the cargo units. The cargo is kept in position by compressive forces rather than tractive forces (See fig.8.11). Timber and board could also be used to protect the units of goods from scraping against each other.

##### 4.3.3.1. Securing of pallet load.

Cargo should be secured onto the pallet by one of the following methods:



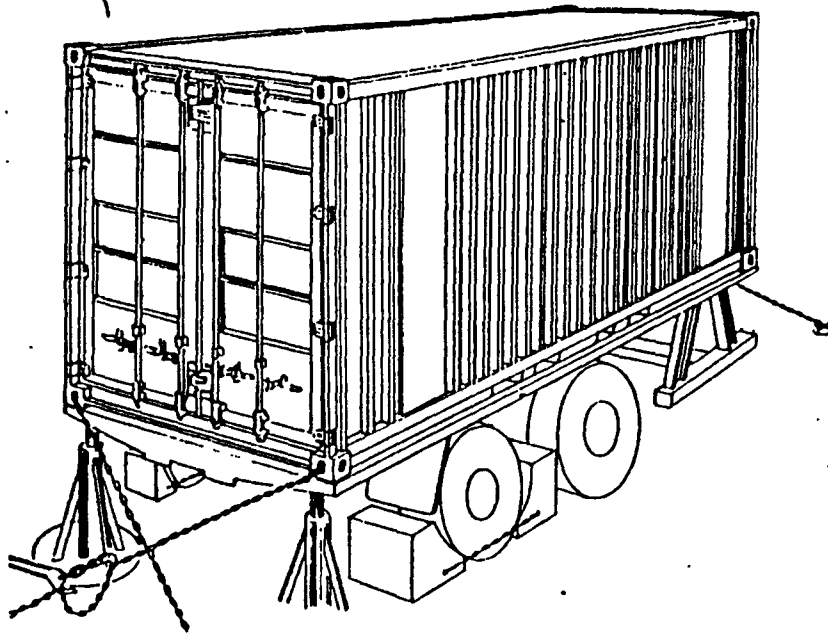

SEMI-TRAILER AND TRAILER LASHING

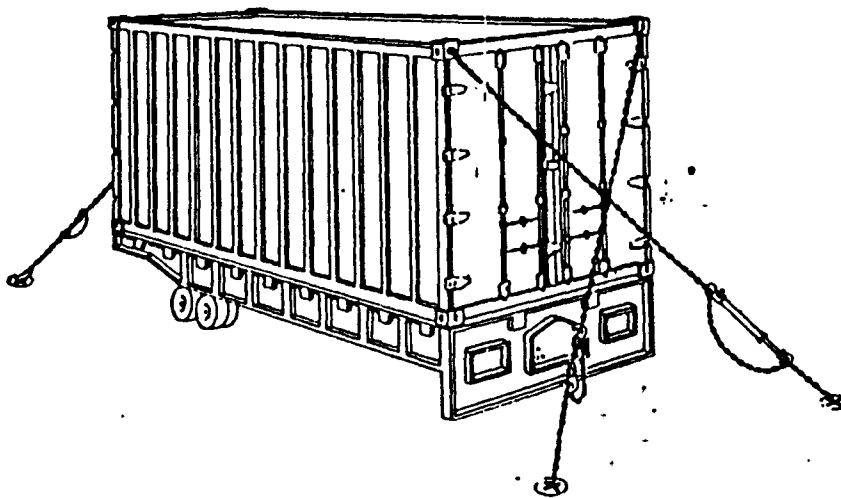

LASHING FOR MAFIS

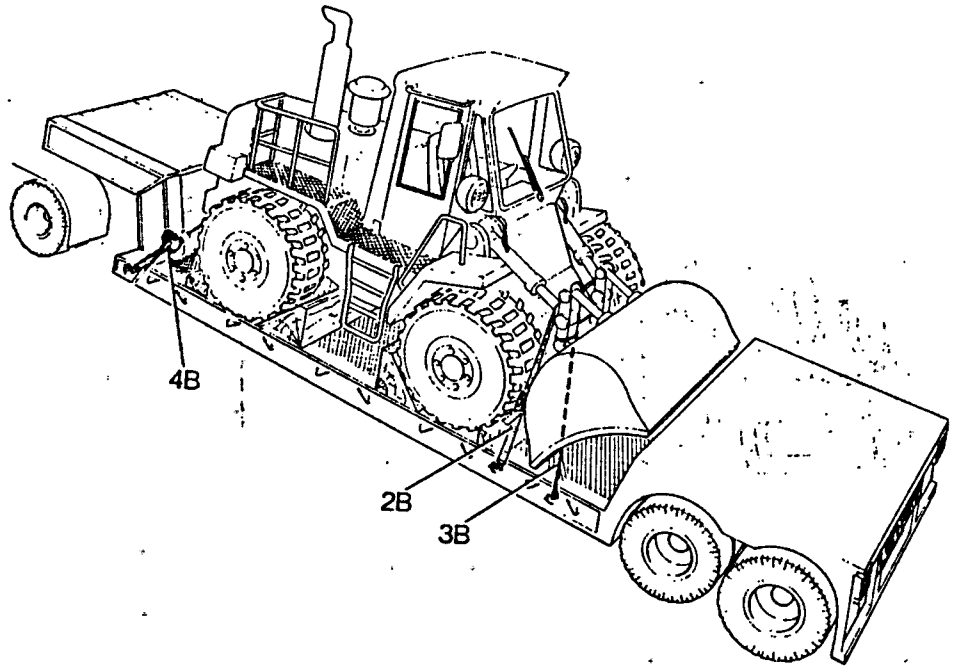

Wheeled Tractor Shovel

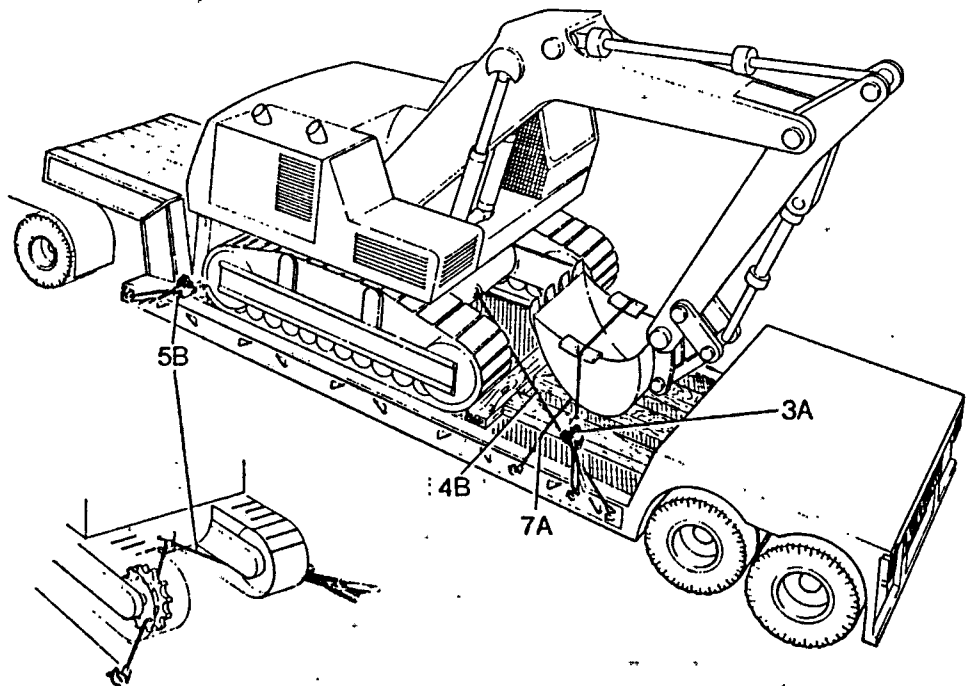

Hydraulic Excavator (Tracked)

- strapping: man made fibre or steel. Banding should pass under the top deck of the pallet. Some cargo may require protection from the point loading of the strapping which may be achieved with dunnage;
- a net usually of polypropylene, and used to secure awkward shaped packages onto a pallet;
- glue for securing regular stows of cartons or bags;
- shrinkwrap: a plastic (transparent) cover over the pallet load which is heat shrunk into place. But this can be a slippery surface for putting other goods on top the pallet. To increase the friction coefficient dunnage is needed;
- locking pattern: unit loads may be built up on pallets with plan dimensions suitable to the modules being handled.

#### 4.3.3.2. Securing of steel products.

- Securing of pits, plates, billets, bars  
When stowed loosely, they can shift during heavy  
her unless effectively secured. The most effective ways to  
secure these cargoes is to level them and overstow them with  
other suitable cargoes;

- Steel coils, ingots, moulds etc, should all whenever possible be stowed in regular tiers side to side of the vessel. Bottom tiers of coils are best supported by two layers of good dunnage placed athwartship to provide drainage for any moisture and protect the tank top. Individual coils in the top tier of the stow are normally secured by driving wedges between the adjacent coils on either side and fore and aft. If loaded in square of the hold, they can be secured by a few wooden blocks against the outermost coils and two steel wire ropes stretched taut across the hold to prevent movement.

- round bars and pipes will not always be adequately

secured by simple leveling off the stow. They can be secured firmly against shifting by using strong wires adequately set up by careful tomming. [25];[26]

#### 4.3.4. Securing of Deck Cargoes.

In this paper, "deck cargoes" refer to items and/or commodities carried on the weather deck of a ship and thereon exposed to sun, wind, rain, snow, ice and sea, so that the packaging must be fully resistant.

Deck cargoes will be subjected to velocity, and to acceleration stresses which, in most instances are greater than on cargo stowed below decks. The lashing and securing of such cargo therefore requires special attention.

According to a seaman's rule of thumb, for securing cargoes with a tendency to move during the voyage is simply that the sum of the minimum breaking loads of all lashings should be not less than twice the static weight of the item of cargo to be secured. This rule may be adequate, or even too much below decks, but it will be adequate on the weather deck only in instances where a fair weather passage can be guaranteed. By voyage with e.g. winds force 6 upwards, together with the wave heights, this rule will not be adequate enough.

In such cases, the sailor's rule of thumb tends to be that, the sum of the "safe working load" of all lashings shall equal the static weight of the cargo item to be secured; the safe working load being arrived at by dividing by 3 the minimum break or slip load. When the intended deck cargo consists of heavy individual units, such as vehicles, trailers, rail cars and large boxes etc, and when severe weather conditions are likely to be expected, the deck cargo securing arrangements should:

- be made of suitable physical means such as: cross bracing at sides and ends using chain lashings fitted with rigging screws;
- consist of lashings used to secure cargo which should have a breaking load of at least 3 times

the design load (designed load being the total weight of the cargo or cargo plus vehicle subjected to acceleration (athwartships, vertical and longitudinal));

- possibly make use of webbing slings and webbing lashing for cargo securing purposes. Webbing is frequently used in conjunction with, and part of lashing formed of chain and less commonly of wire;
- for the attachments, make use of shackles and turnbuckles. [17]

By securing deck cargo the coefficient of friction should be considered: metal on steel or timber on steel etc. This coefficient can be increased by using adequate means e.g. dunnage between the two contacting surfaces. In case of deck cargo, the friction coefficient can be reduced by water.

#### 4.4. CARGO SECURING CALCULATIONS.

As it is already pointed out in the previous paragraph of this chapter, the question of cargo stowage and securing systems on board ship can be divided into three different categories: standardized systems, semi standardized stowage and securing and non-standardized stowage and securing.

While the main distinguishing features of these three categories are the level of standardization of cargo units plus the level of adaptation of the particular ship to the cargo, they also imply different ways of practical decision on proper stowage and securing. The randomness currently associated with non-standardized stowage and securing can now be ironed out with simplified yet accurate models of reality. The necessary simplifications mainly involves:

- Replacing the dynamic process by which forces arise with a static situation in which the equilibrium of forces and load moments can be examined;
- Replacing probabilistic calculations of the distribution of external forces with assumption of peak values;

- Introducing a homogeneous calculation for the distribution of securing forces with an added safety factor.

With standardized systems of cargo stowage and securing, the master can rely on comprehensive instruction based on precalculations acceptable to relevant authorities. Even for semi standardized systems, the master and his crew, have to exercise a measure of interpretative skills, but they can depend on a corpus of empirical evidence. The situation is completely different with non-standardized systems, where the entire decision process is thrown onto the shoulders of the master and his officers, to obtain correct stowage and securing at reasonable cost and often this brings the master into conflict with owners and charterers.

There are several calculation models existing, in use or proposed. Most of them serve specific purposes, as the securing of containers on adapted ships, or the securing of trailers in RO/RO ships. Only a few are designed for the use with non-standardized situations.

The intention in this paragraph, is to take the guesswork out of this most difficult area of cargo safety on board ship, and the numerical and graphical data related to that, are composed of three major components:

- \* A system of basic data plus correction factors for attaining assumptions of external forces acting on cargo;
- \* A recommendation for assessing the strength of securing material and securing devices, including the establishment of an individual safety factor;
- \* The balance of forces and moments for the final examination of the suitability of any stowage/securing system chosen.

The aim can best be met with an approach being in line with shipboard procedures. Stowage and securing arrangement is established by common sense or thumb rule in the first place. Calculations may then be used in order to examine the

suitability of the arrangement. This basic approach can be distinguished from others which give as a result the required number of particular securing devices or the required strength of a given number of devices, and these aims will impair the required flexibility.

#### 4.4.1. External Forces to the Cargo.

The existing mathematical models for calculating external forces were unable to deal effectively with the fact that many new built vessels, particularly those with large B/D relations, tended to be somewhat stiff. Such vessels need a higher initial stability in order to gain a sufficient range of positive righting levers and therefore considered as stiff in minimum stability conditions. In practice, they are very often above the required minimum GM which makes them even stiffer. The rump model for calculating a transversal acceleration (ay) allows some influence for short periods of roll, but gives adequate weight to roll amplitude.

$$a_y = g \cdot \sin \phi_m + Z * \ddot{\phi}_m * (2 \pi / T_\phi)^2 \quad \text{m/s}^2$$

$$g = \text{acceleration of earth (9.81 m/s}^2\text{)}$$

$$\phi_m = \text{assumed maximum amplitude of roll}$$

$$Z = \text{vertical distance between cargo unit and roll axis}$$

$$T = \text{period of roll (s)}$$

$g \cdot \sin \phi_m$  = static (ay) and  $\ddot{\phi}_m * Z$  = dynamic (ay). (See separate sheet).

#### Example.

$$\phi_m = 25^\circ$$

$$Z = 11\text{m}$$

$$T = 12\text{s}$$

$$g = 9.81\text{m/s}^2$$

$$\sin 25 = 0.4226 \text{ and } 25^\circ \text{ in radian are: } 25/57.3 = 0.4363$$

$$2 \pi = 6.2832$$

$$a_y = g \cdot \sin \phi_m + \ddot{\phi}_m * Z * (2 \pi / T_\phi)^2$$

$$a_y = 9.81 * 0.4226 * 0.4363 * 11 * (6.2832 / 12)^2$$

$$a_y = 5.46\text{m/s}^2 = 5.5\text{m/s}^2 \text{ or } a_y = 5.5/9.81 = 0.56g$$

Some existing calculation models are based on a fixed amplitude of roll and take into account stiffness only by an increase of the dynamic part of  $(a_y)$  in relation with the reduced T .

It is commonly known to seamen, that, stiffer ships are much more often in near resonance roll motion with remarkably increased roll amplitudes than ships with normal stability. A realistic model for the determination of ship acceleration should not use a constant value for  $(\phi_m)$ , but one which varies appropriately with the stiffness of the ship and points out influences both the statical part and additionally the dynamic part of  $(a_y)$ . Only this explains the remarkable difference in the behavior between stiff ships and those with normal stability. For sake of simplicity, the model should include only important parameters such as: ship size, location of the stowage in ship, loaded capacity of the ship stability conditions, area and season of operation and the effects of the wind and sea. Other minor influences would be omitted. The model should be presented in numerical or graphical form rather than as a set of formulae. Regardless of the complexities, experts should face up to the challenge of breaking the results down into a clear display of basic acceleration data together with correction factors for the relevant operational parameters (See Fig. 1 and 2). These data in the figures are valid for the following conditions:

- In the case of marked roll resonance with amplitude above + 30 degrees, the given values of transversal accelerations may be exceeded. Effective measures should be taken to avoid this condition;
- In the case of heading the sea at high speed with marked shocks, the given values of longitudinal and vertical accelerations may be exceeded. An appropriate reduction of speed should be considered.



Longitudinal acceleration =  $3 \text{ m/s}^2$

Transversal acceleration in  $\text{m/s}^2$ :

	7.9	7.6	7.4	7.3	7.3	7.5	7.8	8.3	8.9	
	7.7	7.4	7.2	7.1	7.1	7.3	7.7	8.1	8.7	
	7.4	7.0	6.8	6.7	6.7	6.9	7.3	7.7	8.4	
	7.1	6.7	6.6	6.4	6.4	6.6	7.0	7.5	8.0	
0	0.1	0.2	0.3	0.4	0.5	0.6	0.7	0.8	0.9	LBP

Vertical accelerations in  $\text{m/s}^2$ :

5.6 4.3 3.3 3.0 3.4 4.2 5.3 6.7 8.1

FIG2 Correction factors for accelerations

<p>1. <u>Correction Factors for Area</u></p> <p>Semi-restricted area: 0.87</p> <p>Restricted area: 0.70</p>	<p>2. <u>Correction Factors for Season</u></p> <p>Summer-season: 0.92</p> <p>Tropical-season: 0.78</p>
<p>3. <u>Correction Factors for Length</u></p> <p>Length: 100 80 60 m</p> <p>Factor: 1.04 1.15 1.30</p>	<p>4. <u>Correction Factors for Deadweight</u></p> <p>Deadweight: 80 60 40 20</p> <p>1.02 1.06 1.12 1.20</p>

5. Correction Factors for Period of Roll to Breadth Relation

Relation	0.3	0.4	0.5	0.6	sec/m
Weatherdeck high	1.37	1.35	1.26	1.09	
Weatherdeck low	1.24	1.27	1.21	1.08	
Tweendeck	1.08	1.19	1.16	1.06	
Lower Hold	0.92	1.11	1.13	1.04	

factors to be used for transversal acceleration only.

- In the case of running before large stern or aft quartering seas with a stability, which does not amply exceed the accepted minimum requirement, large roll amplitudes must be expected with transversal accelerations greater than the values given. An appropriate change of heading should be considered. Forces by wind and sea to cargo units above the weather deck should be accounted for by a simple approach:

- \* force by wind pressure (1kN/m)

- \* force by sea sloshing (1kN/m).

Sea sloshing forces need only to be applied to a height of deck cargo up to 2 metres above the weather deck or hatch top. For voyages in restricted area, sea sloshing forces may be neglected. Forces from wind and sea obtained by this rule should be added both to transversal and longitudinal forces from accelerations. Form sheet may be used for the compilation of forces (see fig. 3). It seems acceptable to do a securing calculation only on the transversal forces, which can produce transversal sliding and/ or tipping of a cargo units. The effect of vertical forces may be respected by estimation of the loss of friction combined with transversal and longitudinal forces of 60% of the given values.

#### 4.4.2. Securing Forces to the Cargo

By talking about the securing of cargo principally three types of securing devices can be distinguished: namely

- lashings which absorb tractive forces;
- shores or stanchions absorbing pressure forces;
- locking devices absorbing sheer forces ( friction may be considered as a kind of locking with a friction coefficient between steel and timber or steel and rubber not exceeding 0.3).

Securing devices may be characterized by their load-deformation, behavior or elasticity and their breaking load.

FIG 3 Formsheets for compiling external forces

Ship data: LBP = \_\_\_ m; B = \_\_\_ m;  $T_{\phi}$  = \_\_\_ s  
 $T_{\phi}/B$  = \_\_\_; loaded to \_\_\_ % tdw

Cargo data: dimensions: l = \_\_\_ m; w = \_\_\_ m; h = \_\_\_ m  
 mass = \_\_\_ t

Stowage data: x-location at \_\_\_ LBP; z-location: \_\_\_

Operation data: season: \_\_\_; area: \_\_\_

Loads by acceleration.

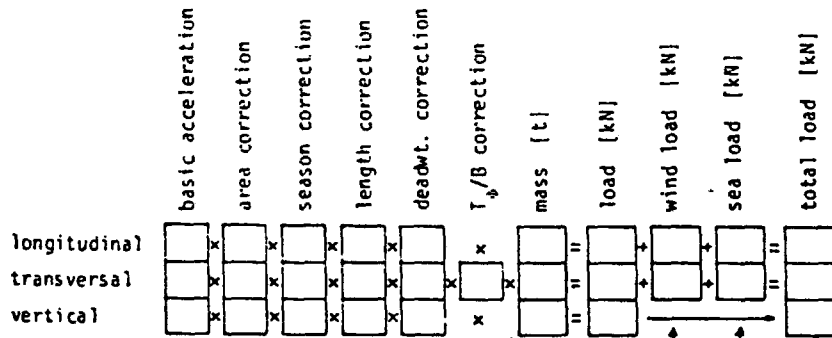

Wind loads

longitudinal  $w \times h \times l =$  =

transversal  $l \times h \times l =$  =

Sea sloshing loads\*

longitudinal  $w \times 2 \times l =$  =

transversal  $l \times 2 \times l =$  =

\* if  $h < 2$ , then put h instead of 2

The breaking load given by the manufacturer on sample tests, is not a suitable strength norm for maritime purposes, because materials which are exposed to frequent loads in bad weather (in contrast with road or rail traffic), tend to deteriorate after frequent use even when loaded well below the breaking load. With certain securing elements such as: shackles, turnbuckles and chains, it is in the case of reusable material certainly the yield strength which should not be exceeded. For these reasons the "Bremen Port Training Centre" uses a "Maximum Securing Load" (MSL) as a more accurate yard stick value worked out in Bremen for different materials including: polyester and polypropylene rope, wires rope of different thickness, shackles, turnbuckles and deck rings (See table No.1 where some typical MSL-values for different materials can be obtained with the diameter (d) in centimeter. It should not be forgotten that the strength of securing devices is further influenced considerably by the quality of implementation i.e., number and tightness of wire clips, avoidance of sharp corners, cross-stiffening of timber shores etc. According to the Hooke's law, elasticity varies considerably. Particularly between securing devices in non-standardized applications, it is advisable to use only devices of similar elasticity in parallel applications. Lashings very often have to be installed in a direction which fails to realize their maximum efficiency. The tractive force (L) can be divided into three components within the ship's coordinate system using the vertical lashing angle ( $\alpha$ ) and the horizontal lashing angle ( $\beta$ ) (See fig.4). However, the tractive force (L) itself is a function of various parameters, which can be shown for a simple transversal lashing with a vertical angle ( $\alpha$ ) by the following formula:

FIG 4 Components of lashing force

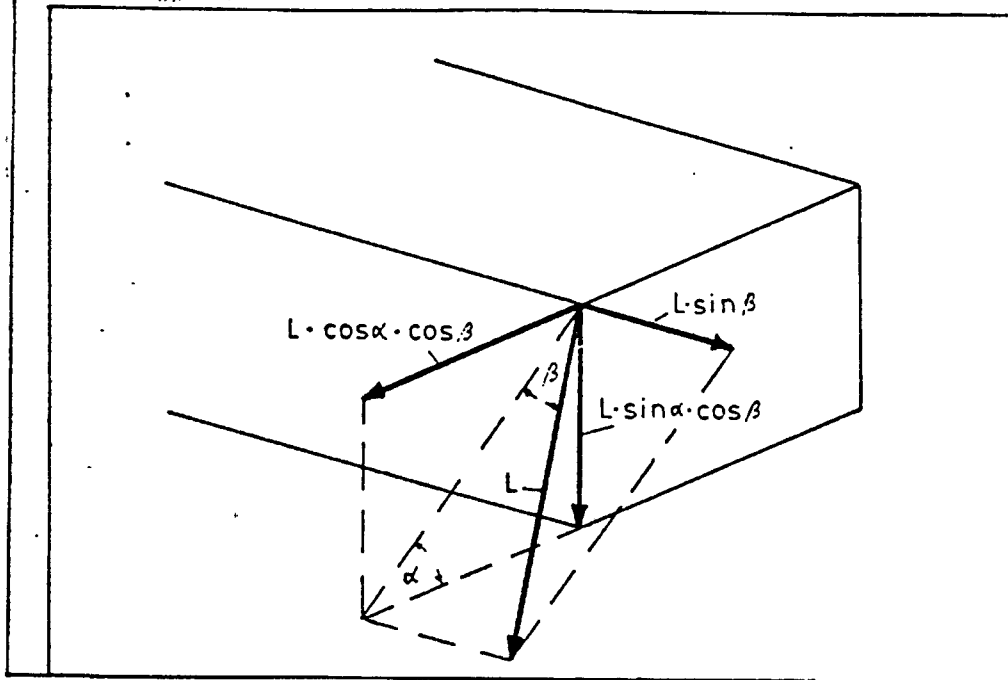
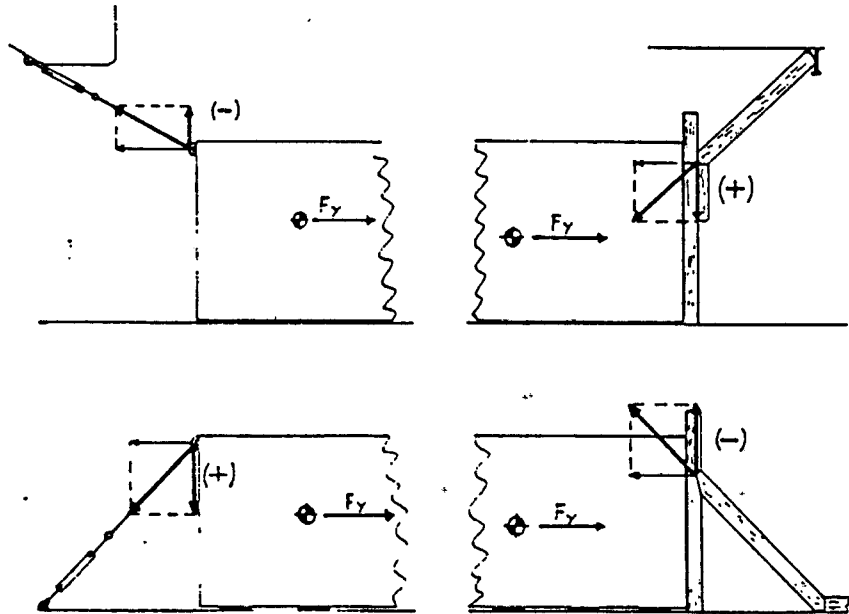

FIG 5 Sign of vertical component of securing force



$$L = E \cdot A \cdot \frac{\Delta y \cdot \cos \alpha}{l} + P$$

- E = modulus of elasticity (kN/cm)  
 A = cross-section (cm<sup>2</sup>)  
 α = lashing angle (rad)  
 y = transversal shift of cargo (m)  
 l = length of the lashing (m)  
 P = pretension (kN)

**Example.**

$$L = E \cdot A \cdot \frac{\Delta y \cdot \cos \alpha}{l} + P$$

P = 0  
 E = 1 \* 10<sup>4</sup> kN/cm  
 A = 2 cm<sup>2</sup>  
 α = 30°  
 l = 6 m  
 y = 1 cm = 0.01 m

$$L = 1 \cdot 10^4 \cdot 2 \cdot \frac{0.01 \cdot \cos 30^\circ}{6} = 28.9 \text{ kN}$$

It is purely impossible to attain a homogeneous distribution of securing forces within a complex securing arrangement.

But it can be aimed for by:

- Using uniform types of devices in terms of cross-section and elasticity;
- Installing them at similar angles and lengths in so far as possible;
- Cancelling unavoidable differences by applying pretensioning variations.

For ship board securing calculations any sophisticated analysis of the before mentioned particulars of securing devices must be omitted and replaced by a plain approach.

using the (MSL) and allowing for various uncertainties by an appropriate safety factor. The calculated strength of a lashing or securing device is its "Maximum Securing Load" (MSL) divided by a safety factor, to allow for adverse events such as( non-homogeneous distribution of forces within the securing arrangement, external forces above assumed levels, bad assembly of securing device, etc). [10]

#### 4.4.3. Safety Factor (SF).

The safety factor for the securing of cargo on board ships has to cover uncertainties in the calculation of the lashing force, as well as uncertainties in the strength of the lashing equipment. The safety factor can be divided into three parts:

- The first part is the safety factor, which shall cover the uncertainties in accelerations and forces acting on the cargo due to ship motions and wind forces at sea;
- The safety factor covering uncertainties in cargo parameters (location of centre of gravity, geometry of lashing to deck, coefficient of friction, pretension of lashing etc);
- The safety factor covering uncertainties in the lashing equipment (inhomogeneous distributed forces within the securing arrangement, strength of device reduced due to bad assembly etc). The safety factor is defined as:

$$SF = \frac{\text{Maximum Securing Load}}{\text{Calculated Lashing Strength}}$$

(See fig.6)

The probabilistic character of these events permits the use of the Root Mean Square Formula to compute an overall safety factor from separately defined safety factors:

Polyester rope		d · d · 5
Polypropylene rope		d · d · 4
wire rope 6 x 19 + 1F	one-way use	d · d · 40
wire rope 6 x 29 + 1F	re-usable	d · d · 15
wire rope 6 x 19 + 7F	one-way use	d · d · 20
shackle (mild steel)	} no deformation desired	d · d · 12
turnbuckle ("-" )		d · d · 12
deck ring ("-" )		d · d · 12

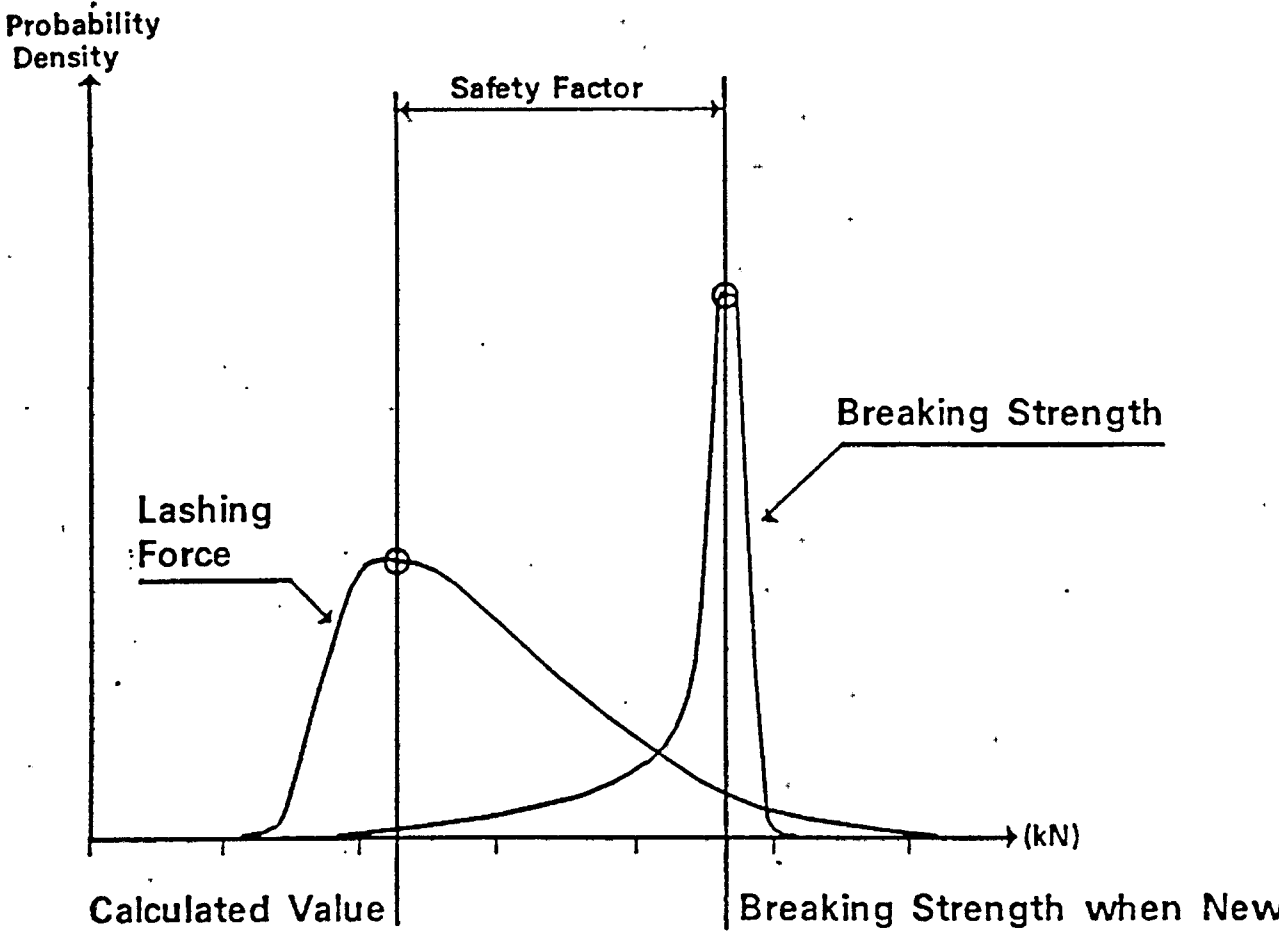

Safety factor of securing equipment



$$SF = 1 + \sqrt{(S1-1)^2 + (S2-1)^2 + (S3-1)^2 + \dots}$$

SF = overall safety factor

S1,2,3,n = separately defined safety factor.

It should be reminded that a safety factor determined in that way must not be used against breaking strength, but only against maximum securing load, because the difference between breaking strength and maximum securing load should not be considered as probabilistic in this particular sense.

There are some factors which influence the safety factor such as: the ship's accelerations, the cargo parameters and the lashing parameters. [10]

**\* The ship's acceleration.**

The common practice in shipping is that accelerations and forces acting on the cargo at sea are calculated using a probability level of  $10^{-8}$ , which means that maximum accelerations and forces will occur once every 20th year of continuous service at sea. These rather extreme values mean in themselves a high degree of safety against getting higher values.

**\* The Cargo parameters.**

The type of cargo, and its possibility to be lashed on deck is of course one of the most important factors resulting in the lashing force. The important parameters are: total weight of the unit, location of the centre of gravity, angles of lashing, coefficient of friction and pretension of the lashing. Most of the parameters seem to be obvious and well known. However, when going in the detail of their true figures of each parameter it becomes quite soon clear that, the expected value usually varies. This variation should be compensated by an appropriate safety factor.

**\* Lashing parameters.**

The lashing parameters can be defined as the influence of the lashing itself on the securing. The most important factor is thus the capacity of lashing. Traditionally, the only way to specify the capacity has been the breaking load of the

equipment. Although, lashing can be tested when new, it is essential to determine the capacity of the lashing after some time of operation. This will need a statistical evaluation of the capacity of the lashing equipment in use on board the ship. A usage factor will then enter the picture. [1]

#### 4.4.4. Balance of Forces and Moments.

Turning to the question of balancing forces and moments ( where an external force from either side is counterbalanced by securing forces from the respective opposite side, while any "lee side" lashings are slack), the equations can be simplified by ignoring longitudinal forces and any horizontal lashing angles ( $\beta$ ) which would give rise to longitudinal components of securing forces. This requires a sufficient amount of longitudinal components of securing devices as well as friction to cover external longitudinal forces. It should be noted, that longitudinal components increase with  $\sin\beta$ , while the appropriate transversal and vertical components decrease with  $\cos\beta$ .

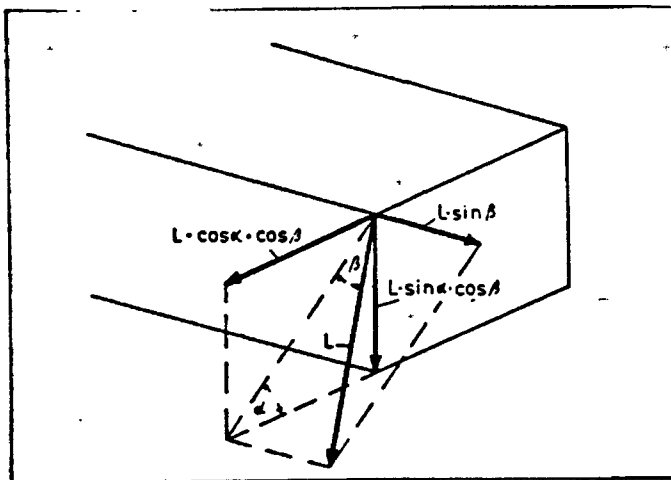

Thus any horizontal securing angle should be limited to a maximum of 30 degrees, otherwise an exclusion from the balance calculation should be considered.

A vertical securing angle ( ) greater than 60 degrees will cause a remarkable lower loading of the particular securing device when the cargo unit slides. Therefore, it is advisable

that the devices should be disregarded from the balance of forces unless the necessary load is gained by a tipping tendency and this throughout the voyage.

The first mathematical approach of the balance of forces and moments, is the consideration of the friction. The friction between stowage surface and cargo unit bottom contributes strongly to the absorption of transversal forces. This friction force may be obtained by the formula:

$$R = \mu * [ 0.8 * m * g + \sum_{i=1}^n (L_i \cdot \sin \alpha_i) ]$$

with :

R = friction force [kN]

$\mu$  = dynamic friction coefficient

m = mass of the cargo unit [t]

g = gravity acceleration of earth = 9.81m/s

n = number of securing devices

$L_i$  = calculated strength of securing device(i) [kN]

$\alpha_i$  = vertical securing angle of securing device.

The term ( $L_i \cdot \sin \alpha_i$ ) represents the vertical component of the securing force contributed by the particular securing device. When this component is directed downward, it should be a positive value, otherwise as a negative value (See fig.5).

#### 4.4.4.1. Balance of Forces.

Once we have calculated the friction force, it is will be used within the balance of forces which can be expressed as follows:

$$F_y \leq R + \sum_{i=1}^n (L_i \cdot \cos \alpha_i) \quad (1)$$

with :

$F_y$  = transversal force from load assumption [kN]

R = friction force [kN]

$L_i$  = calculated strength of securing device(i) [kN]

$\alpha_i$  = vertical securing angle of device (i)

n = number of securing devices

The basic formula (1) means that the system will be in equilibrium when the sum of all calculated lashing devices strengths in addition to the friction force (R) will be equal

or greater than the transversal force from load assumption ( $F_y$ ).

The balance of forces should generally be calculated for both sliding to port and sliding to starboard. In the case of side stowage or with a symmetric securing arrangement in the case of single stowage, one appropriate calculation will be sufficient.

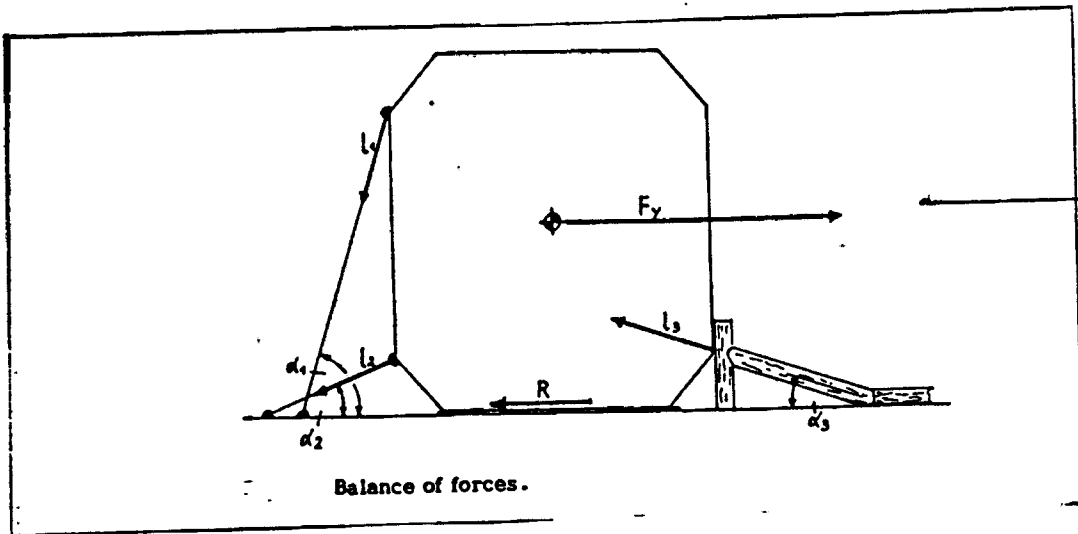

**Example.**

A 54t transformer is loaded into the lower hold in "single-stowage" patterns. The transformer will be secured by four lashings to each side having a MSL of 130 kN each. Determine the balance of forces of this lashing system.

Safety factor(SF) = 1.7

Load assumption  $F_y = 351$  kN. Friction coefficient ( $\mu$ ) = 0.3  
 $(\alpha_i) = 55^\circ$ .

1. Determination of the friction force (R)

$$R = \mu \cdot [ (m \cdot g \cdot 0.8 + \sum_{i=1}^n l_i \cdot \sin(\alpha_i)) ]$$

The calculated strength(l) = MSL/SF = 130/1.7 = 76.5 kN

$$l_i = n \cdot l = 4 \cdot 76.5$$

$$(\alpha_i) = 55^\circ \quad \sin(\alpha_i) = 0.819 \quad m = 54t, \quad g = 9.81m/ss$$

$$R = 0.3(54 \times 9.81 \times 0.8 + 4 \times 76.5 \times 0.819) = 202.3 \text{ kN}$$

2. The balance of the forces.

$$F_y \leq R + \sum_{i=1}^n l_i \cdot \cos(\alpha_i)$$

$$F_y = 351 \text{ kN}, R = 202.3 \text{ kN}, \cos(55^\circ) = 0.574$$

$$351 \leq 202.3 + 4 \times 76.5 \times 0.574 = 377.8 \text{ kN}$$

$$351 \text{ kN} \leq 377.8 \text{ kN}$$

#### 4.4.4.2. Balance of Moments.

The same would be applied to the balance of moments.

If this balance is not fulfilled, this may lead to a tipping of the cargo unit. The basic formula for balance of moments is expressed as follows:

$$a \cdot F_y \leq b \cdot 0.8 \cdot m \cdot g + \sum_{i=1}^n (C_i \cdot L_i)$$

$a \cdot F_y$  represents the tipping moment of the cargo unit.

$a$  = lever-arm of tipping [kN]

$F_y$  = transversal force from load assumption [kN]

$b$  = lever-arm of stability [m]

$m$  = mass of the cargo unit [t]

$g$  = gravity acceleration of earth =  $9.81 \text{ m/s}^2$

$n$  = number of securing devices

$C_i$  = lever-arm of securing force of device(i) [m]

$L_i$  = calculated strength of securing device(i) [kN]

N.B.

$$\sum_{i=1}^n$$

is an algebraic sum.

The factor  $C_i \cdot L_i$  represents the securing moment and its sign should be positive with a rotation contrary to that of the external moment ( $a \cdot F_y$ ), negative with a like-wise rotation. It is important to remind that, for practical calculations the lashing angles ( ) and the levers ( $C_i$ ) do not need to be determined for each particular lashing, an average figure for group of similar lashings will be sufficient.

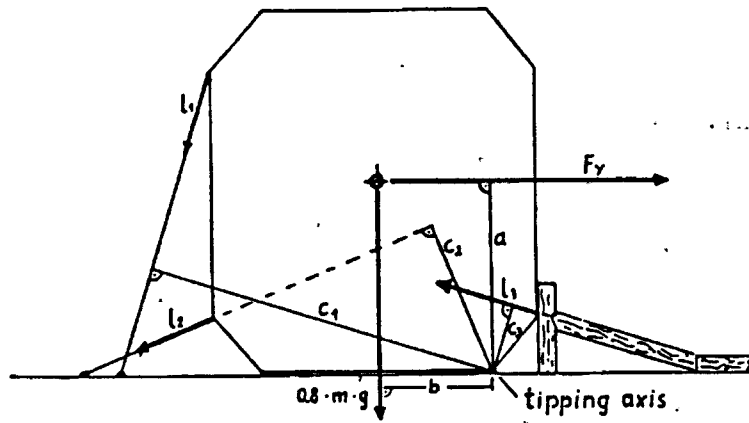

Balance of moments.

**Example.**

$m = 40t$

$L1 = L2 = 70 \text{ kN}$

$a = 2.9m$

$b = 2.0m$

$C1 = 6.6m$

$C2 = 0.5m$

$n = 10 =$  number of the securing devices

$Fy = 1282.5 \text{ kN}$  is a calculated value of  $Fy$

Balance of moments:

$$a * Fy \leq b * 0.8 * m * g + \sum_{i=1}^n (Ci * Li)$$

$2.9 * 1282.5 < (2 * 0.8 * 140 * 9.81) + 10(70 * 6.6) - 10(70 * 0.5)$

$3719.3 \text{ kN} < 2197.4 + 4620 - 350 = 6467.4 \text{ kN}$

The cargo unit according to the balance of moments will not tip away. [10]

**4.4.5. Worked example.**

A harbour launch of 80t is to be shipped on top of hatch No.2 of a multipurpose vessel.

The vessel's data are the following:

LBP (length between perpendiculars) = 140m, B = 21.5m the roll period ( $T\phi$ ) = 13s the ratio  $T\phi / B = 0.6$

The vessel is loaded to 60% of its tdw.

Cargo data:  $m=80t$ ,  $l=28m$ ,  $w=6m$  and  $h=5m$ .

Stowage data: x-location at 0.7 of LBP and Z-location deck

high. Operation-data season: summer, area: unrestricted. For the compilation of external forces, the appropriate form sheet is used (See separated sheet).

The safety factor is calculated as follows:

- Load assumption may be exceeded by the factor 1.2;
- Variation of strength of securing material shall be respected by the factor 1.2;
- Reduction of strength by unfavourable assembly of securing devices shall be accounted for by the factor 1.3;
- Excessive loads due to inhomogeneous load distribution within the arrangement shall be accounted for by the factor 1.5

The overall safety factor (SF) is calculated:

$$SF = 1 + \sqrt{(S1-1)^2 + (S2-1)^2 + (S3-1)^2 + \dots}$$

$$SF = 1 + \sqrt{(0.2)^2 + (0.2)^2 + (0.3)^2 + (0.5)^2} = 1.65$$

The launch is intended to be stowed on a wooden cradle and lashed by wire-rope lashings, assembled with clips and tightened by turnbuckles. The 16mm wire-rope of standard design is used doubly and will account for an MSL of 200 KN per lashing which is to be reduced to 140 KN due to unavoidable sharp bends of the wire-rope. The MSL of the attached deck eyes, shackles and turnbuckles is well above 140 KN.

MSL	140	
Calculated strength =	-----	= 85 KN
SF	1.65	

The securing arrangement is symmetrical regarding the port and starboard side (See separate sheet)

Thus for the following calculation only one side needs to be considered. The dynamic friction coefficient ( $\mu$ ) between timber and painted steel is taken as 0.3 with respect to wetness and vibration. It is intended to fit 4 upper

✓

lashings at an angle of  $(\alpha_1) = 34^\circ$  and 4 lower lashings running nearly parallel to the deck on each side with  $(\alpha_2) = 2^\circ$ . Thus the friction force (R) is calculated:

$$R = 0.3 * [0.8 * 80 * 9.81 + 4(85 \sin 34^\circ) + 4(85 \sin 2^\circ)]$$

$$R = 249 \text{ kN and } F_y \text{ taken from the form sheet is: } F_y = 859 \text{ kN}$$

Balance of forces will be:

$$859 < 249 + 4(85 * \cos 34^\circ) + 4(85 * \cos 2^\circ)$$

$$859 < 871 \text{ kN}$$

The calculation shows the balance tending to the favourable side. Balance of moments reads:

from the drawing we have the following data:

$$a = 1.4\text{m, } b = 2.5\text{m, } C_1 = 5.0\text{m } C_2 = -0.6\text{m}$$

the balance will then be:

$$1.4 * 859 < 2.5 * 0.8 * 80 * 9.81 + 4(85 * 5.0) - 4(85 * 0.6)$$

$$1202 < 1570 + 1700 - 204 = 3066$$

Balance of moments:

$$1202 < 3066$$

The calculation shows that tipping is most unlikely with an intact timber cradle.

If the cradle would be washed away, the tipping axis would be at the keel of the launch showing the following lever-arms:  $a = 2.0\text{m, } b = 0\text{m, } C_1 = 4.1\text{m, } C_2 = 0\text{m}$ .

The balance would immediately prove an imminent risk of tipping by:

$$2.0 * 859 > 4(85 * 4.1)$$

$$1718 > 1394 \text{ kN.m}$$

Thus some securing of the cradle would be strongly advisable. Because of the temporary reduction of the normal force subsequently the reduction of the friction, an adequate longitudinal securing is therefore necessary.

As conclusion, we can say that, the proposed techniques are highly flexible by reason of the numbers of parameters used in the assumption of external forces, the ways to arrive at an overall safety factor, and because the balance calculation is not restricted to any particular arrangement of securing devices. On the other hand they have the disadvantage of not



giving any advice on how to start implementing the securing arrangement. This is still left to the experience and skill of ships' crews and lashing gangs. [10]

Ship data: LBP = 140 m; B = 21.5 m; T<sub>0</sub> = 13 ;  
 T<sub>0</sub>/B = 0.6 ; loaded to 60 t  
 Cargo data: dimensions: l = 28 m; w = 6 m; h = 5 m  
 mass = 80 t  
 Stowage data: x-location at 0.7 LBP; z-location: deck high  
 Operation data: season: Summer ; area: unrestricted

Loads by acceleration

	basic acceleration	area correction	season correction	length correction	deadwt. correction	T <sub>0</sub> /B correction	mass (t)	load (kN)	wind load (kN)	sea load (kN)	total load (kN)
longitudinal	3.0	1	.92	1	1.06	=	80	= 238	30	12	= 276
transversal	7.8	1	.92	1	1.06	= 1.07	80	= 663	140	56	= 859
vertical	5.3	1	.92	1	1.06	=	80	= 443			= 443

Wind loads

longitudinal	$w \times h \times l = 6 \cdot 5 \cdot 1 = 30$
transversal	$l \times h \times l = 28 \cdot 5 \cdot 1 = 140$

Sea sloshing loads\*

longitudinal	$w \times z \times l = 6 \cdot 2 \cdot 1 = 12$
transversal	$l \times z \times l = 28 \cdot 2 \cdot 1 = 56$

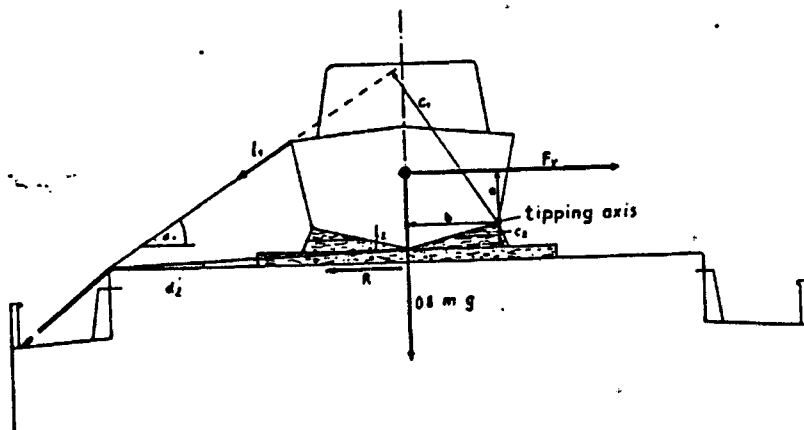

Illustration to worked example.

## CHAPTER 5: THE PRACTICAL USE OF SECURING MATERIALS.

It is the duty of shipowner and master to ensure that all items of cargo on board are secured in a manner which, will, as far as is practicable, prevent their movement relative to the ship in the worst weather conditions which may normally be expected on any intended voyage.

In making this statement however it is fully recognized that it is extremely difficult to state with any certainty the number and strength of lashings needed to secure any particular item of cargo safely to the deck of the ship. The reason for this difficulty is the number of variable factors which need to be established before an accurate assessment of the lashing requirements can be made. These variable factors include: the weather conditions and ship's heading, the forces to which the cargo unit will be subjected, the size and the weight of the unit and the position of its centre of gravity, the position and angle at which the lashings are inclined, the coefficient of friction between the various bearing surfaces, and the safe working load of the lashing equipment.

Probably, the method of dealing with this complex problem was to rely on experience and past practice. Nowadays, the most effective method is the new scientific approach to this problem, which enables the use of lashing arrangements which have proved successful at times when very severe weather conditions have been encountered. These lashing arrangements are divided into two categories of equipment: the fixed securing equipment and the loose securing equipment. This chapter is intended to describe first of all the different kinds of securing material, their possible failure when they are used and finally to give some practical advice regarding the securing of cargo and the required behavior in heavy weather conditions.

### 5.1.- THE DIFFERENT KINDS OF SECURING EQUIPMENT.

### **5.1.1.Fixed Securing Equipment.**

When a ship is contracted to a shipyard and the cargo to be carried is specified, a stowing pattern, as well as amount, strength and location of fixed securing equipment is decided upon. Fixed securing equipment are i.a: lashing terminals and container supports.

#### **5.1.1.1. D-rings and lashing plates.**

D-rings, lashing plates and deck sockets are used as lashing terminals. These terminals could be fixed or foldable, single or double and they could be protected against overturning either by a protective disk or by being fitted flush to the deck. Folding rings could be used in more directions than fixed rings and double rings are used if lashings are to be applied in several directions at the same time. The lashing plates which could be fixed or foldable are used when several lashings are to be fixed in the same lashing terminal and the lashing directions are predictable, and the lashing plates could be more cheaper.  
(See separate sheet).

#### **5.1.1.2. Container supports and deck sockets.**

Container supports on deck are designed differently, and they vary from each other according to the hole shape, height above deck and whether they can be locked or not. Deck sockets are often used as container supports and could also serve as lashing terminals. They are fitted flush to the deck or projected above deck, either completely or with low profile. The key-shaped sockets are flush, whereas the other sockets are welded on the deck. Deck sockets can further be locking or non-locking. A locking socket provides vertical restraint as well as horizontal restraint.  
(See separate sheet).

#### **5.1.1.3. Corner guides.**

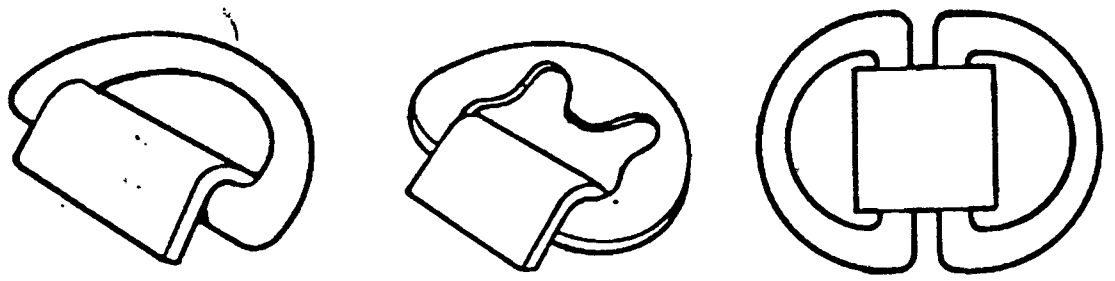

3 Different types of D-rings

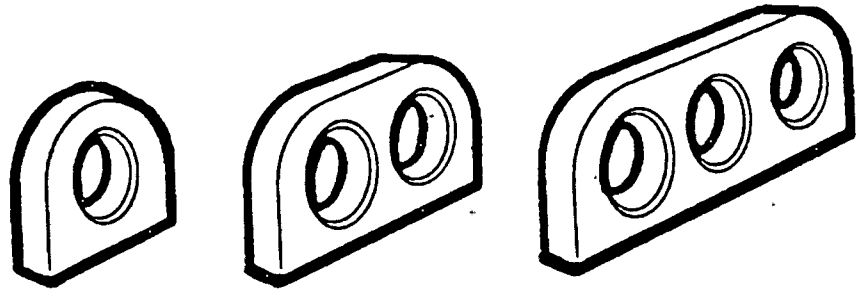

4 Lashing plates

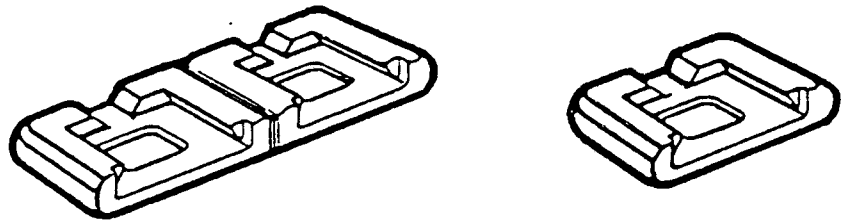

5 Locking deck sockets

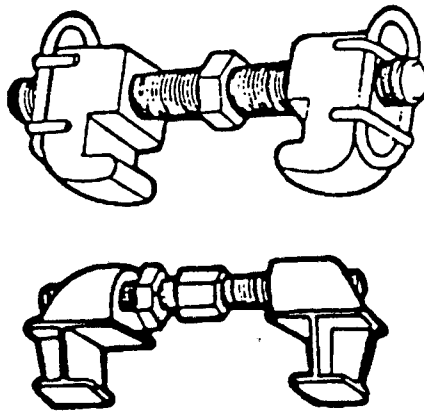

6 Bridge fittings

Corner guides are a special type of container supports. They are used along the angled sides to guide the container into its position. Corner guides, which are mostly welded onto the deck, are often heavier and more expensive than deck sockets which are more common.

(See separate sheet). [2]

#### 5.1.2.- Loose Securing Equipment.

Loose securing equipment includes: lashing equipment such as wire, rod, web and chain equipment for the stacking of containers, tensioners etc. Different types of hooks are used for rods, web, wire, and chain. The use of twistlocks becomes more and more common.

##### 5.1.2.1. The hooks.

Different types of hooks are used for rods, wires and chains. Four types of hooks can be distinguished:

- elephant's foot
- a chain hook
- eye-hook
- penguin-hook.

**MariTermAB**

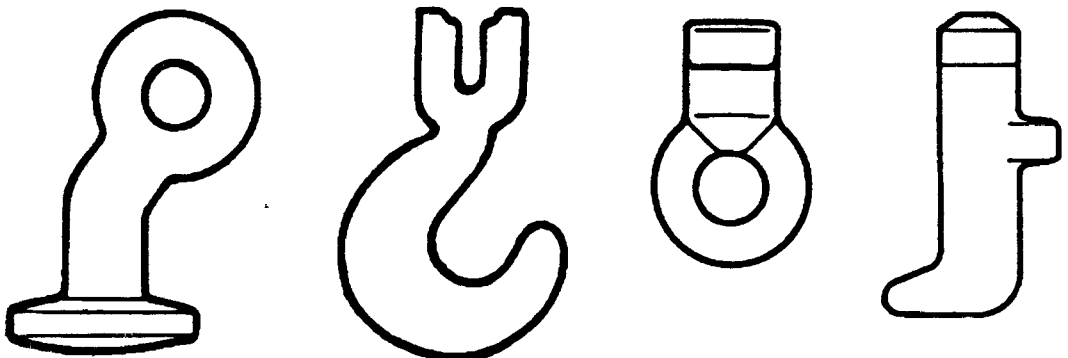

Hooks

### 5.1.2.2. Stackers.

Stackers or stacking cones are the vertically connecting links between the deck and the container or between containers. They are fitted with one end into the deck socket the other into the corner casting of the container. There are several types of stackers:

- the non-locking stackers (the ISO-stackers and the double intermediate stacker cones);
- pinlocking stackers;
- twistlocking stackers.

The pinlocking stacker is simply a stacker cone locked to the corner casting by a pin, which could be inserted either from side or from the end of the corner casting. Pinstackers are simpler and cheaper than twistlocks, but are not as strong.

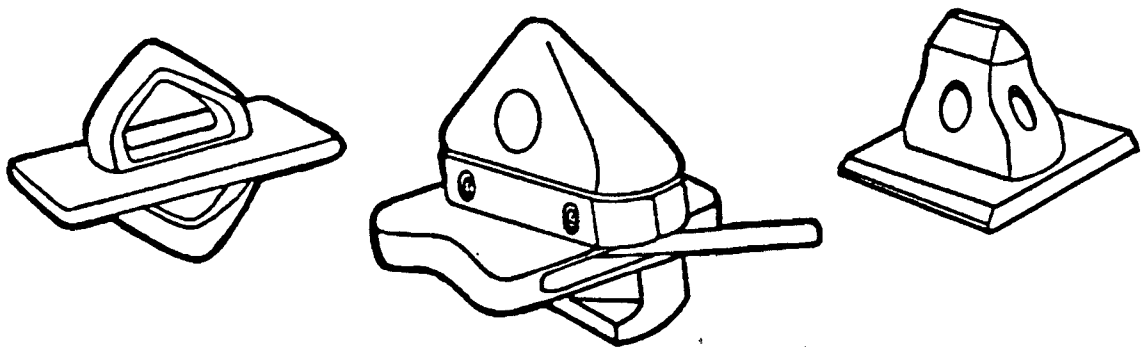

Stacking cones

### 5.1.2.3. Twistlocks.

Twistlocks are sophisticated intermediate stacking cone

allowing the vertical connection between two containers, and avoiding the rising movements of the containers or stack. It consists of a steel body in which centre a shaft with cones at each of its ends is located; a shaft which can be rotated approximately 90 degrees by means of a protruding lever so as to lock together two containers in vertical sense. The lower cone of the shaft is generally displaced 25 degrees in respect to the upper cone and thus giving place to three lever positions:

- The first one keeps the lower cone aligned with the body, allowing to fit the twistlock on top of the lower container in its position;
- In the second position the lever locks the lower cone and leads the upper cone to its aligned position, so that the upper container can be placed;
- Finally, the third position of the lever locks the upper and lower cone connecting thus the two containers together.

New twistlock standard is planned by some countries such as UK, Australia and USA in order to prevent many accidents. The main objective of a new twistlock standard, is to ensure that, even in poor visibility conditions, lashers can easily see whether twistlocks are the correct way up and whether or not they are locked. The standard would also include a requirement that all twistlocks in use on board ship lock in the same direction.

There are also automatic twistlocks. These are locked automatically under the pressure of the container and unlocked when a knob is knocked by a rod. In practice, automatic twistlocks have not worked satisfactory.

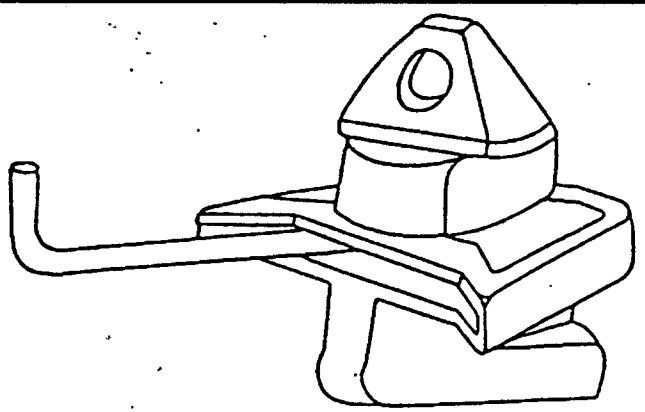
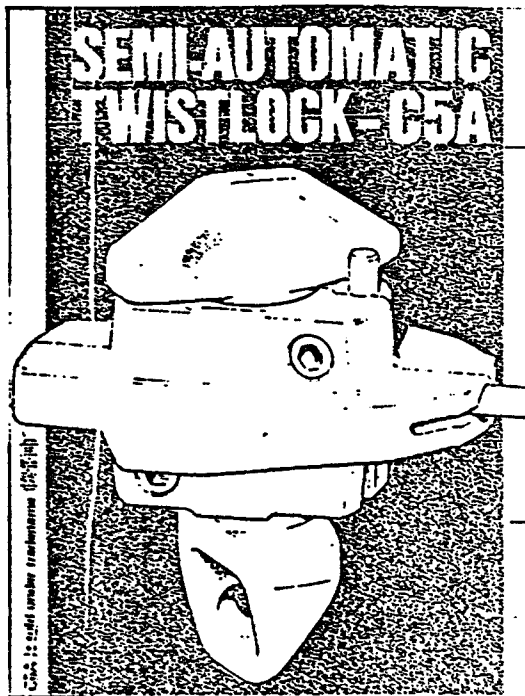

Twistlock

#### 5.1.2.4. Tensioners.

There are many types of tensioners on the market. Some of them can be used together with several kind of lashings, others with one type of lashing only.

##### 5.1.2.4.1. Turnbuckles.

The turnbuckle or bottle screw is the oldest type of tensioner and therefore known by operators all over the world. It can be threaded at one end or both, it can be open or closed and it can be equipped with a fixed or detachable hand wheel for tensioning. Turnbuckles are simple and safe and therefore quite common, in particular when securing containers with rods. They are also flexible and can be used with chain, as well as wire. They are comparatively heavy and expensive and if the thread is damaged, they easily get stiff. Therefore they have to be greased regularly.



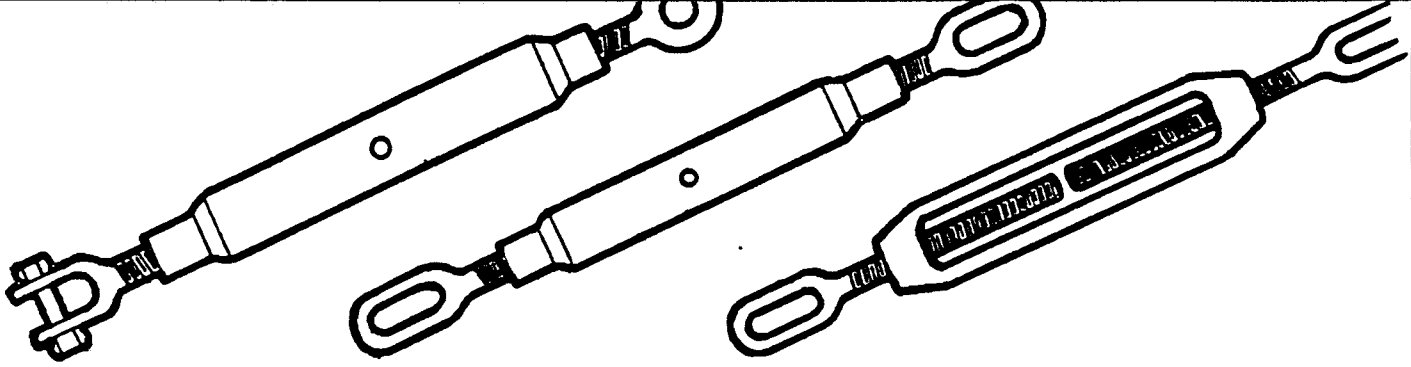

2 Different types of open and enclosed turnbuckles

#### 5.1.2.4.2. Lever tensioners.

Lever tensioners are used with chain only and they are the most common tensioners for trailer lashings. The weight is low, they are comparatively cheap and they do not need much maintenance. They require a lot of space and they are dangerous to tension in rough weather. The reason for this is that they first have to be slackened and then tightened. In the meantime, the cargo is not secured which is a risk. They can cause injuries by springing when being released. Many types with different quality exist on the market:

- The quick release tensioner is designed for use with wire lashing. It is quick to use and cheap to manufacture, because all the components are cast. The quick release tensioner also requires more space than e.g. the turnbuckle. As the lever tensioner, the quick release tensioner has to be slackened before retightened which can cause injuries in bad weather.
- In recent years, several new tensioners have been introduced. Among these hydraulic and pneumatic tensioners can be noted. They require less applied force and it is possible to apply the same tension in all lashings. They are, however, more expensive than the traditional tensioners. They have become popular because they are light, quick and safe to use.
- The quick tight- tensioner can be tensioned pneumatically as well as with an hydraulic hand pump. Turnbuckles too, can be tensioned pneumatically e.g. by using the speed lash tensioner, which can tension up to 4-5 tons, is safe quick and requires little

space. But the source of power is often a problem.

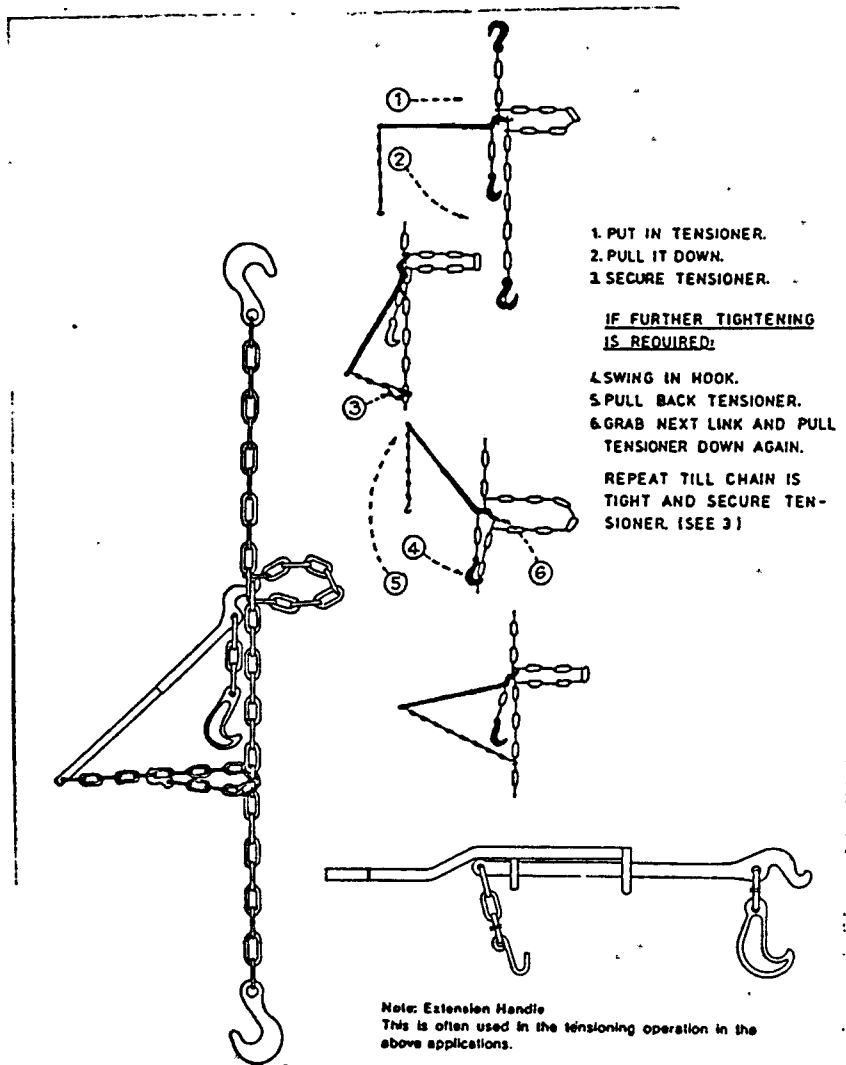

#### 5.1.2.5. Chain Lashings.

The use of chain alone for the securing of general deck cargoes is not widespread. Hence, it is widespread used in the securing of freight containers, vehicles and trailers. For general purposes it is used most effectively in relatively short lengths in conjunction with and as part of lashings otherwise composed of wire or webbing. Chains used alone as lashing equipment are long-linked. The reason for this being that there must be space between the links so that a tensioning lever, or other equipment for tensioning the lashing can be used. One advantage of this is that the weight will be less than of a short-linked chain.

The normal dimension used in lashing equipment is a 13 mm diameter with a guaranteed breaking load above 20 tonnes. Another normal dimension is a 11 mm diameter with a guaranteed breaking load of 15 tonnes. A chain is characterized by its break load, a proof load which is a two-thirds of the break load and finally a safe working load which is one half of the proof load. It is the safe working load which must be the prime governing factor. (See separate sheet). [17]

#### 5.1.2.6. Wire Lashing Equipment.

In the early days of container lashing, wire was quite common. Later on, when rods, twistlocks, etc had been developed, wire as lashing equipment became obsolete, although today it can often be found on board ships as straps in different lengths. For goods that are lashed to a roll trailer, flat rack or semi-trailer, wire is still being used quite frequently. The main reason for wire being unpopular as lashing equipment is that it is difficult to work with and also dangerous. The manner in which the wire is locked with wire clips is slow and indeed not very safe. The wire will be impaired if bent in a small radius and thus lose some of its ability to resist fatigue. The advantages are its low weight and its flexibility and elasticity.

An assembled wire lashing consists of wire, sufficient wire clips and a bottlescrew to pretension the lashing. For efficient lashing purposes, wire ropes should be round-strand, flexible and not so great in diameter. The most common of such general purpose wires is 16 mm diameter of 6\*12 construction galvanized round-strand with a minimum breaking load of 7.74 tonnes.

#### 5.1.2.7. Rod Lashing Equipment.

Rods are very common as container lashing equipment. They came as replacement for wire and the advantages are many. They are easy to use, their weight is acceptable and

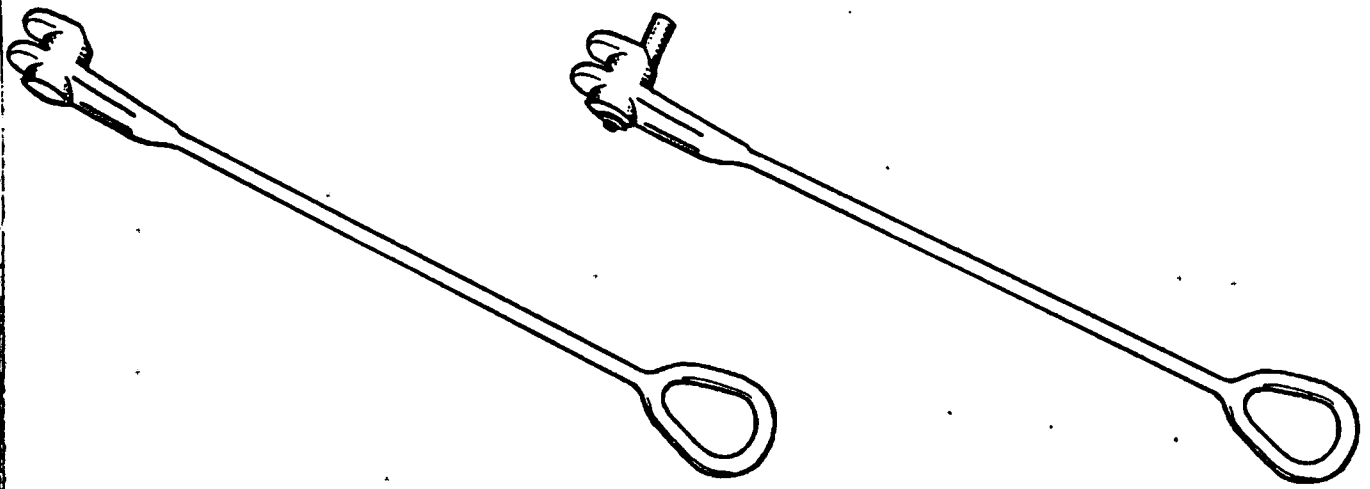

Rods for the securing of containers

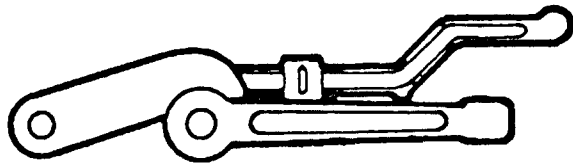

Quick release tensioner

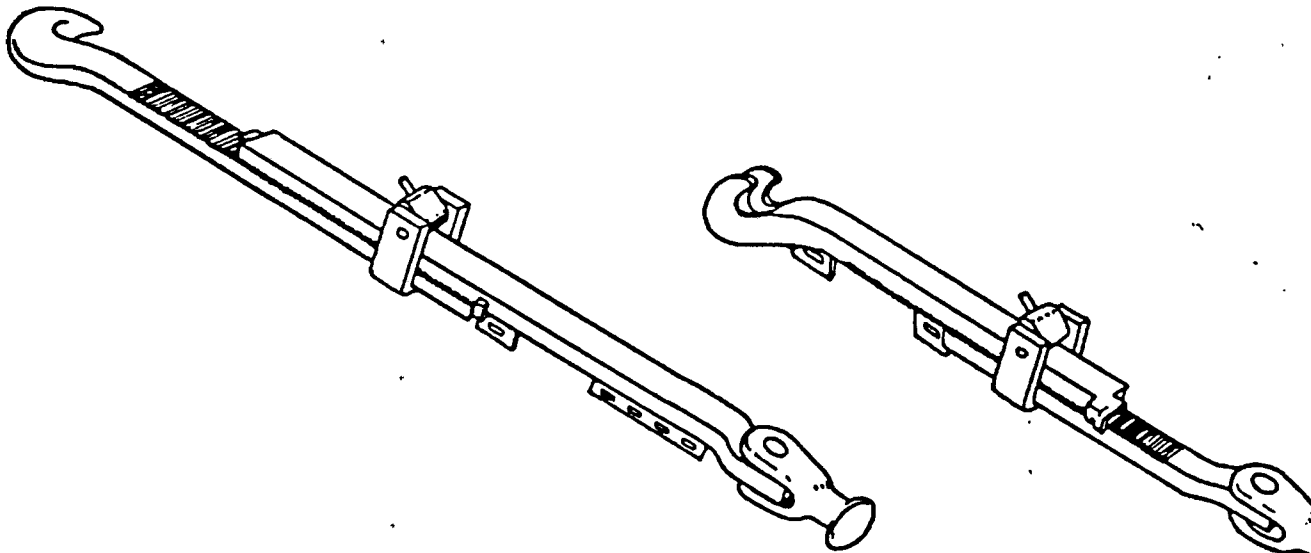

Quick tite tensioner for rods and and chain respectively

they are very resistant to wear and tear. Their E-modulus is very high, the elongation is about 0.2% at the yield point if no original bending is given to the rod. The rod should be used in combination with some sort of tensioner of which there are several types on the market. The rod is made of high-tension steel which gives it a poor resistance to high load amplitudes concerning the question of fatigue. (See separate sheet).

#### 5.1.2.8. Web Lashing Equipment.

There are a number of different types of web lashings available on the market both with regard to quality and design, as well as the specified minimum break load capacity. The normal type for heavier cargo is polyester straps. This type has the highest resistance to oil, chemicals, sea water and sunshine. However, even though it has the highest resistance, it is not completely resistant. Sand and dirt between the fibres decrease the strength and therefore the straps are painted and treated in different ways to increase the ability to withstand sand and dirt. The resistance ability decreases as the strap is being used.

The main advantages of web lashings are:

- Easy to handle because of its low weight and its tension winch;
- Low E-modulus which would decrease the lashing forces (about 18% elongation at break load);
- Worn out and damaged lashing straps can be found by visual inspection.

The disadvantages of web lashing are:

- poor resistance to wear and tear. The web lashing quickly loses a substantial part of its breaking load;
- for some types of winches, poor resistance to withstand the pressure when run over by vehicle wheel;
- Low E-modulus which may lead to too large elongation before the actual lashing forces have been taken up. (See separate sheet). [17]

#### **5.1.2.9. Self-tightening (and slacking) lashing system for trailers.**

The last invention for cargo securing is a self-tightening and slackening lashing unit for trailers. This tensioning device which is used to tie down and secure trailers to the deck of Ro/Ro or Container vessels, will work with wire rope, chain or webbing or any other material. The tensioning buckle is therefore designed so that it will automatically increase the tensioning as the load increases in line with the increased movements of the ship and cargo. As the weather becomes calmer and the movements reduced, the buckle will slowly release tension. The buckle has two chambers: 5a and 5b (See figure on separate sheet). There is a bar (No. 28 on the figure) at the bottom of which there are one way valves, which will let the oil pass from chamber 5a to 5b. This happens when the spring is activated by movements creating slack in the system, slack which is immediately taken up by the spring. As the cargo moves, the slack appears and the buckle continues to take up such slack thus continuously adding tension. The oil flowing from chamber 5a to chamber 5b is prevented from moving in the opposite direction by the one way valves. When the vessel meets improved weather conditions, the movement of the cargo is reduced and the oil is allowed to slowly filter back to chamber 5a. In this way, the tension is slowly reduced, that enables a easier final release in port. [27]

#### **5.2. SOME PRACTICAL ADVICE REGARDING SECURING OF CARGO.**

##### **5.2.1.- Sources of Failure in Lashing Arrangements.**

The cargo unit must be secured against the dynamic load. There are different ways of setting up securing arrangements, and this depends on the type of cargo unit (barge, container trailer car, packed goods pallets etc.) According to the cargo unit type, the securing devices can be

FIG 10 Web lashing for securing of trailer

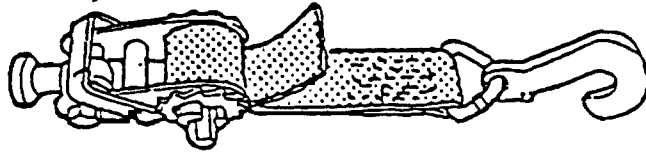
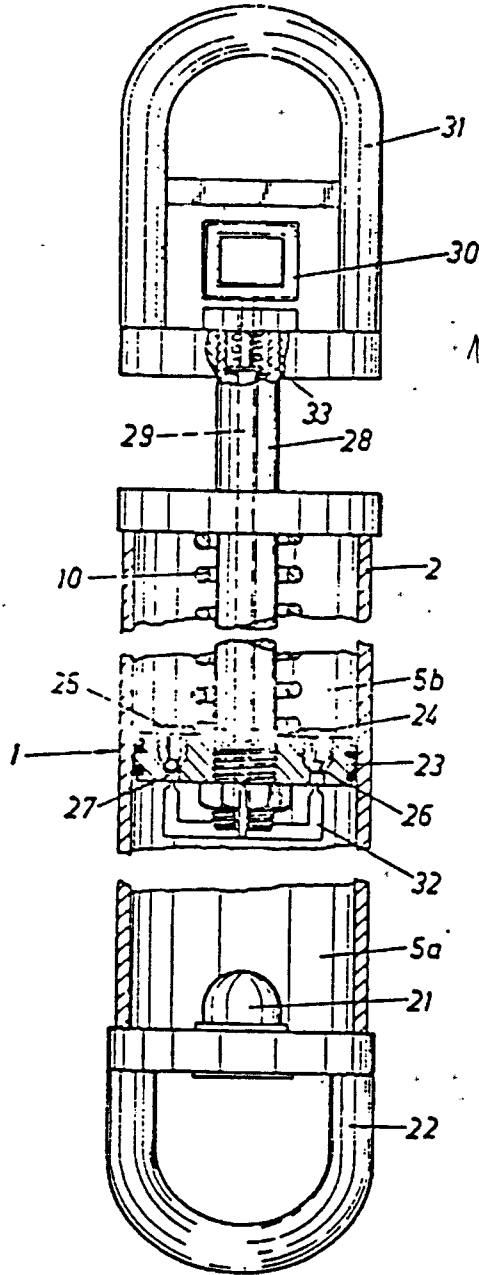

FIG 1 SELF-TIGHTENING (and SLACKENING)  
LASHING-SYSTEMS FOR TRAILERS.



subdivided into:

- Ready-made cargo securing devices which are the most efficient arrangements for permanent use (e.g. racks and guide structures for containers);
- Assembled cargo securing devices used for securing of various types of cargo units which size and amount are not foreseeable, special short-term devices for securing have always to be set up.

The failure of any cargo securing device can be caused by two reasons:

- \* breakage due to overload at insufficient strength which is one of the properties of securing device;
- \* unfavourable arrangement of securing devices this property of the securing device may be called its "physical efficiency".

The physical efficiency of the securing device depends on various physical parameters beyond its strength and they may be judged by considering the share of load taken by the particular device in a specific securing arrangement. The strength of the lashing material diminishes during its lifetime and depends on certain parameters such as:

- \* magnitude of tension load;
- \* frequency and size of load variations in time;
- \* size and direction of bending on lashing material;
- \* turning radius of lashing when changing tension force direction;
- \* mechanical wear;
- \* corrosion.

But what is important in this part of the paper, is to sum up some diminishing of the strength and physical efficiency by inefficient workmanship and faulty arrangement of lashings which can reduce the general holding capacity (some examples for illustrating the idea, see separate sheet).

According to the experts estimation, lashing directed around sharp corners can have 25% of its strength diminished. Guiding around sharp corners, welding failures, improper use



of clamps and improper application of lashing eyes are also sources of lashing strength reduction. Where no general devices have been prepared at the design stage (for instance with container and Ro/Ro ships), it is possible to have more failures in the securing devices.

#### 5.2.1.1. The ready-made securing devices.

They are commonly used for the securing of container and Ro/Ro units and are designed for full life-time of the ship. The sources of the strength reduction are:

- \* frequency of loads;
- \* several peak loads;
- \* mechanical wear;
- \* corrosion.

Regarding their physical efficiency, it depends highly on the design of the individual securing system where the required strength of each device should be calculated according to the actual required load with respect to the load distribution, lashing angles, elasticities and dynamic behaviour of the secured unit. The physical efficiency of the whole system is affected by the uncertainty of the user, who introduces pre-tensioning in the lashing. As a result, low pre-tensioning gives reason to slack and unexpected movement of the unit, while high pre-tensioning may result in extreme high loads. In both cases failure of the system may follow.

#### 5.2.1.2. Assembled securing devices.

Where required sizes, strength and applications are not foreseeable, the assembled securing devices, which consist of lashings and blocking arrangements (e.g. timber) are used. Wire ropes, shackles, clips and turnbuckles are for example the elements of such lashing devices. To evaluate the strength of the lashing system, the strength of the weakest element will be taken into consideration, including securing points too (rings, eyes). The strength can be highly reduced due to several specific reasons which result in a poor

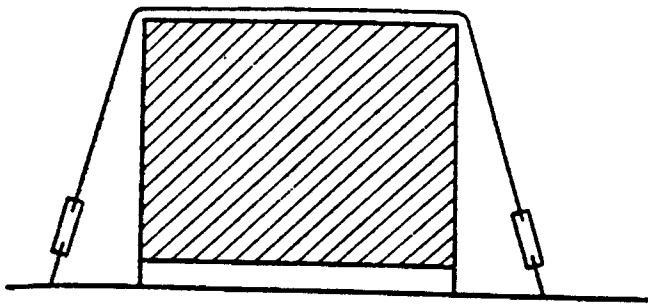

Lashing Side-to-Side  
not advisable

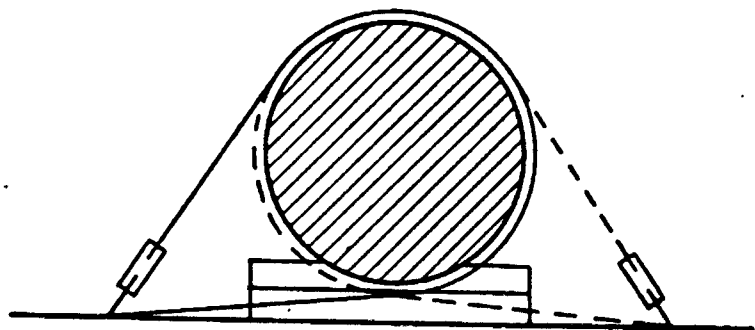

One-Sided-Half-Turn Lashing for  
defined holding direction  
advisable

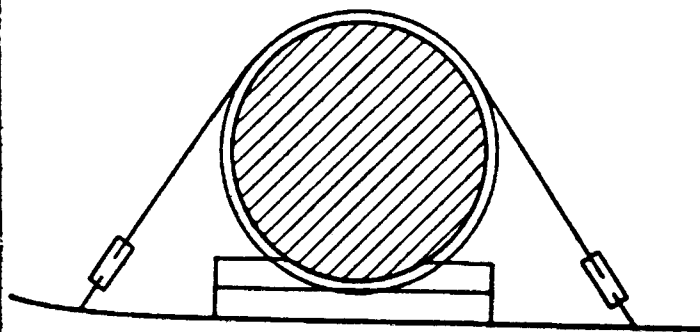

Lashing Side-to-Side with Roundturn  
not advisable

Fig. 7.1:

Examples of Lashing Wire Attachments

workmanship(e.g. wrong attachment of clips, insufficient number of clips, guiding of wire-ropes round narrow bends or even sharp corners).

The strength can be reduced when the securing elements are re-used. In most of cases, elements like wire-ropes, fibre-ropes, timber and sometimes turnbuckles and shackles are only used as one-way material.

The physical efficiency of assembled securing devices may be affected most of the time by:

- \* unfavourable lashing angles;
- \* unfavourable attachment to the unit regarding its centre of gravity;
- \* wrong attachment to a unit without securing points (side-to side or side -to side with round turn);
- \* unsuitable or different elasticities with respect to length and size of lashings;
- \* unsuitable pre-tensioning of lashing;
- \* insufficient lateral supporting of timber arrangements. [11]

## 5.2.2. Some Practical Advice and Recommendations.

### 5.2.2.1.Regarding container securing.

- The securing of containers on deck is the responsibility of the ship's staff, although not necessarily carried out by them.

It is important that all rod and wire lashings are sufficiently tight but not too tight to strain fittings, containers etc.

The correct bridging pieces, twistlocks etc should be checked in position between tiers. It should be clearly ascertained and understood which way twistlock handles are put for the locking position, which should be in the same direction for all twistlocks on the ship so that a quick glance is all that is needed to ensure that the locks are indeed engaged.

- In cellular vessels, containers are put down cell

guides and landed one on top of the other. No further securing is required in these circumstances. Some ships exist with guides above deck for similar purposes.

Containers stacked one above the other without the benefit of cell guides must be secured one to the other with twistlocks and /or a combination of locating cones, bridging pieces, lashing rods, wires etc, to prevent any form of shifting. The blocking in of containers in a stow with unitized or general cargo is important. To facilitate this and to spread the load on the container sides, or walls, large dunnage, bags might be used to advantage. Containers that are not blocked in as above must be properly secured with wire, rod or chain lashings to prevent any movement and to reduce the strain of racking on the container. This is particularly important if two or more containers are stowed in a vertical stack. It is also important that the corner castings are used to secure the container. A wire lashing for instance passed over the top middle section of the container does not secure it adequately and can only damage the container.

Extra lashings are recommended to the bottom of the second container tier during heavy weather conditions or where ship motions are severe. In the stack with 3 or 4 tiers, long and short cross lashings are required while for 2 tiers or 1 tier short cross lashings only are necessary.

#### **5.2.2.2. Regarding vehicles and other wheel-based cargo securing.**

- When stowing and securing wheel-based cargoes at sea, the cargo holds in which wheel-based cargo is to be stowed must be clean and the surface must be free from grease and oil.

- Vehicles and loads presented for shipment should be in acceptable satisfactory condition(ship officer responsibility to be satisfied on this).

- Securing points and appropriate trestles, or trailer horses etc should be used to by-pass the springing system of

vehicles, so that during the movement of the vessel at sea the vehicles remain rigidly secured.

- By securing trailer with load, the lashing should pass over the top of the load and encompass both load and the trailer together in order to avoid the cargo to move away from the trailer.

- With particularly heavy vehicles it may well be necessary to add to the normal securing devices frictional resistance material placed beneath the unit on to the deck.

- Vehicles carrying dangerous goods should be segregated from other vulnerable cargoes and closely located to firefighting provisions.

- Vehicles with flats, open sided bogies or trailers must be loaded and secured in such a way that the contained cargoes should not move, or slip against the movement of the vessel.

- Lane stowage fore and aft ship is the more desirable procedure with vehicles with brakes on and the engine in gear.

- Tall high vehicles loaded so that their centre of gravity is relatively high, require a particular degree of security and lashing provisions.

- Wheel-based cargo which is not provided with rubber wheels or tracks with friction increasing lower surface should always be stowed on wooden dunnage or other friction increasing material such as softboards.

#### 5.2.2.3. Regarding some break-bulk and unitized cargo securing.

- The stowage and securing of all deck cargo is under the supervision of an appointed deck officer.

On Ro/Ro ships or Ferries, bow and stern or side hull loading doors should be effectively secured and adequately protected against possible damage from vehicles which may break loose.

- Steel plates, guides and plastic-faced boards should be given extra strong securing, preferably chains, and should

be located in position where they can do the least harm.

- Pipes, cylinders and similarly shaped units of cargo require special attention, and the successful securing method for these items is the use of a pipe rack, nesting frame or cradle in association with chain lashings and tightening devices. This type of cargo should always be effectively segregated from the area used for stowing vehicles.

- Individual coils in the tier of the stow are secured by driving wedges between the adjacent coils on either side and fore and aft. Particular attention should be given to cargo in the forward compartment of a ship where the effects of heavy pitching are more pronounced.

- Cargo units and other entities should be stowed in a safe manner and secured as necessary to prevent tipping and sliding. Cargo on pallet should be secured onto the pallets.

#### 5.2.2.4. Some general advice regarding the securing.

- Chains should only be attached to the ship in the permanent fittings. They should never bear over or round sharp structural corners.

- Tensioners should whenever practical be placed so they are easily accessible for retightening at sea.

- Lashings must only terminate in the specially designed lashing points in the ship.

- By using clips for wire lashing, the threads must be greased before putting the nuts on. This increases the holding capacity by being effectively tightened. Wire-clips have to be set with the curve into the slack end of the lashing wire.

- Steel band must not be used where slackening is to be expected of more than 0.5% of length of lashing.

- Where space or commodity does not allow tomming off, a solution is to fill up the space with anything suitable. Hardwood wedges can efficiently be used in a stow of bundles copper ingots. An empty pallet can be used to bridge a gap and or locking a stow. Timber can be used to fill up a gap

between horizontal steel coils.

- Individual pieces may require cross-vertical and spring lashings. Blocks of cargo may require intermediate lashings as well as a secured face.

- A horizontal lashing holds the cargo unit directly in position, any tension is reducing the working capacity. A vertical lashing must have the highest tension possible, because the tension increases the friction on deck. Vertical lashings should mainly be used to prevent tipping over.

### 5.2.3. Avoiding of cargo shifting by good ship handling in heavy weather(good seamanship).

There are several kinds of hazards and damages a ship can encounter during a voyage in heavy weather. Some of these hazards and damages are e.g.

- Total loss where by the ship can capsize or break apart, flood or strand;
- The rolling of the ship can result in damage to cargo by ship's motions(breaking of cargo, shifting of cargo);
- The cargo can be damaged by water when the ship is flooded;
- The ship's bottom and shell can be damaged sometimes the ship's deck as well;
- Also the technical equipment on board can be damaged in heavy weather;

Heavy weather can also cause accidents to persons, accidents which are due to ship's motions(e.g.roll, pitch and heave) or to overcoming of sea (when persons are on deck).

Some remarkable events are necessary to avoid when encountering heavy weather, such as:

- \* an inhomogeneous distribution of buoyancy which can result in loss of stability, stress to the ship(hooging and sagging);
- \* heavy motions of hull(in rolling and pitching);
- \* collision with heavy seas(it is a matter of speed and direction of the sea);
- \* finally, loss of control of ship's way(it is advisable to leave the ship alone to find her way and to keep the speed very low).

Extreme roll motion is the most dangerous motion for cargo and ship. The long-term magnitude of the roll angle amplitude has been taken into account in all requirements and respective formulae on lashing loads.

In order to avoid dangerous roll motion, some basic requirements are necessary.



- a.- Exact information on the total loading status of the ship (i.e. GM, righting lever curve, natural roll period, actual ship speed and heading) is important for the ship master;
- b.- A sharp and concentrated look on the sea environment is needed. Period and height of characteristic waves must be roughly estimated by experienced nautical personnel.
- c.- Dangerous situations from roll resonance must be known not only from former experience of the ship master (which is important though), but must be also comprehensible by simple diagrams given on board ship. The several steps can be taken on board to face the environment whilst at sea; such as: change of ballast, change of ship speed and change of ship's heading towards the waves.

By developing a simple diagram to avoid roll resonance, it is necessary to understand the two possible ways in which resonance can occur:

- Resonance with external exciting forces and moments, mainly in beam seas, from time variations of the excitations-term in the equation of roll motion;
- Mathieu resonance from time variations of hydromechanic properties of the ship in a seaway, mainly in following and quartering sea, and from non-linear coupling with heave and pitch.

Beam sea resonance occurs at the ratio of wave period ( $T_w$ ) to natural roll period of the ship close to one ( $T_w = T_o$ ).

The Mathieu resonance occurs when the wave period of encounter ( $T_e$ ) is nearly one half of the natural roll period ( $T_o$ ), or when they both are nearly equal ( $T_e = T_o/2$  or  $T_e = T_o$ ). Taking all these into consideration, the simple way to avoid roll resonance (which is a dangerous situation for cargo and ship e.g. risk of cargo shifting) would be: the value of the

encounter period wave-ship( $T_e$ ) in following or aft quartering sea must not be equal or half of the natural roll period( $T_o$ ). (See separate sheet for graph).

Some examples showing the use of the graph.

**Example No.1.**

$(\beta)$  = heading wave-ship = 120 degrees

V = ship's velocity = 14 kn

$T_w$  = wave-period  $T_w$  = 10 s.

From the graph, we can get the encounter period of  $T_e = 13$  s

**Example No.2.**

At which heading ( $\beta$ ) do you have resonance when the encounter period ( $T_e$ ) = 12s, the wave period  $T_w$  = 9s and the ship's velocity V = 15kn?

By plotting these different data on the graph, we find:  $(\beta) = 112.5^\circ$

In this case, the resonance may be avoided by altering the heading to the wave ( $\beta$ ) about 15 degrees to port or starboard, depending on the actual situation.

Another way to reduce motion acceleration loads upon cargo and its lashing in the ship's life-time is the use of "Passive and Active Roll Damping".

Most ships have been fitted with passive roll damping devices such as bilge keels. Besides the bilge keels, the uncontrolled and controlled tank stabilizing systems are in use. The passive type is ideal for ships lying on the same spot for some time or moving at reduced speed. Frahm anti-rolling tanks have been provided mainly to ships with acceleration sensitive loads, such as Ro/Ro vessels.

However, agreement must be reached on the standard and reliability of the respective system and device to be asked for. [11];[16]

Diagram for the determination  
of the Encounter Period

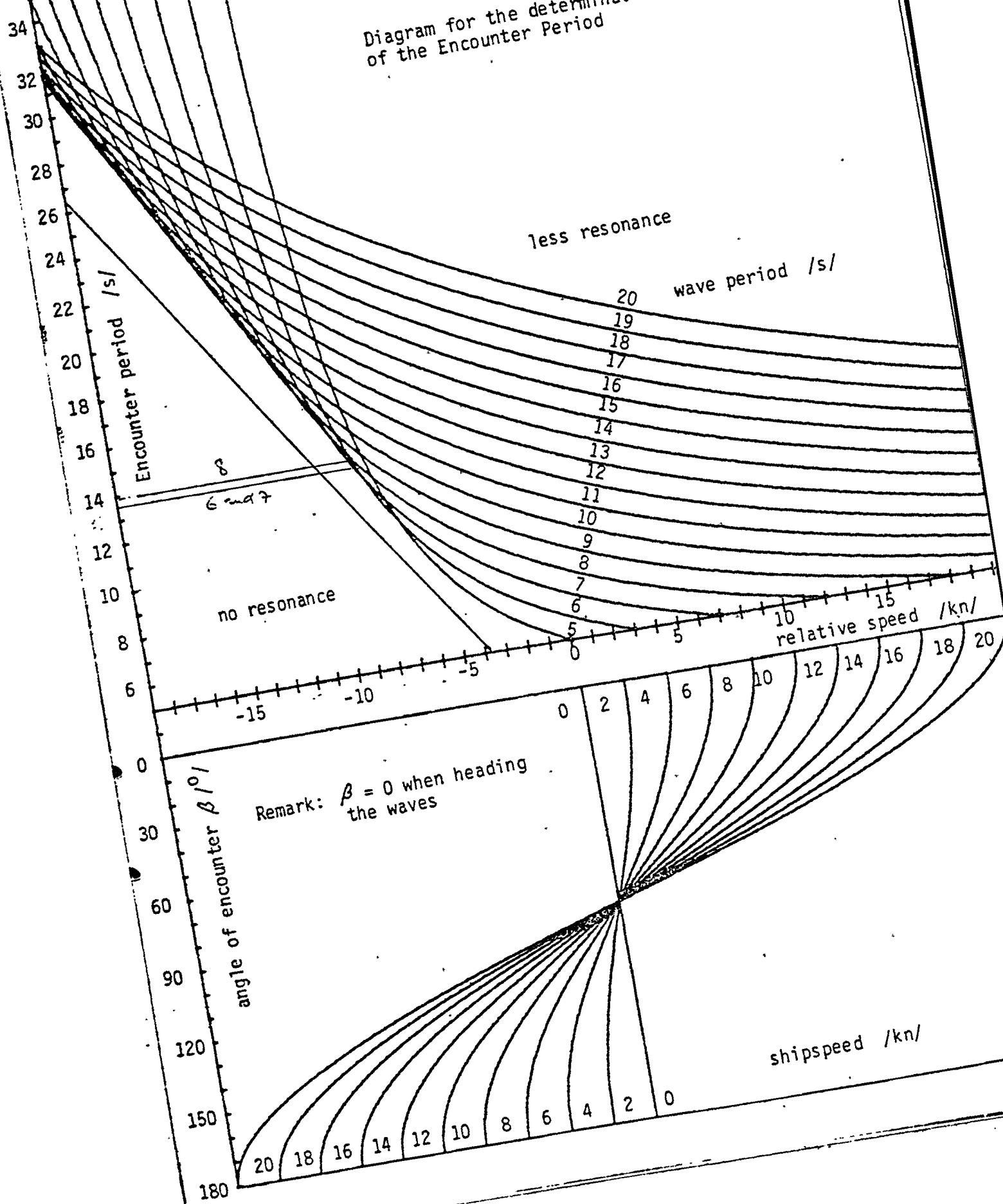

### PART THREE

## EVALUATION OF THEORETICAL AND PRACTICAL TRAINING.

The growing of the vessels, the reducing of crew and the great change in the kind and packing of cargo has brought forward an outstanding and complete change, and cargo securing has become a shore-based job. Lashing of cargo is executed before vessel's departure and only in case of emergency or lack of corresponding shore facilities, this job is done by ship's crew. There are very few shipowners who still leave this work for their own crew.

During the first time, as cargo securing became a shore-based job, it was done by skilled labourers with sea experience under supervision of experts who sailed for years as mate or master mariners.

Nowadays, this job is mainly executed and supervised by labourers and men without any sea experience. Besides this, the sea transportation of full cargoes on pallets, containers, construction parts, deck cargo and vehicles/trailers, which needs a careful and safer securing than cargo existing of bags, cases and drums, must be taken into consideration. The education and training of officers and masters worldwide does not realize the problem of lashing and securing. Also many port experts are still of different opinions whether proper handling of lashing wires, bottlescrews should be taught in training courses for port-labourers. A look through the well known books on cargo handling, stowage, ship's handling and seamanship, has never dealt with the subject "cargo securing" completely in its details.

Many suppliers and producers of various lashing material are publishing a lot of printings about the safe working load, breaking power, wire sizes of their products. They hardly ever give any indication how to handle their products properly. A great number of persons involved in the maritime transportation system of cargo rely on the skill of the

person packing and securing goods into the containers or vehicle/trailers such as:

- road vehicle drivers and other highway users when the unit moves by road;
- rail workers and others, when goods are carried by rail;
- dock workers when the unit is loaded or discharged;
- crew members and passengers of ships at sea;
- marine cargo underwriters.

All may be at risk from a poorly packed container or vehicle in particular one that is carrying dangerous goods.

Therefore, only well trained personnel should carry out all essential precautionary measures with regard to the preparation of stowage areas, vehicles, or holds, the proper loading and stowage and securing, all other vital measures, which will not only guarantee the safety of the goods, but the safety of the ship and her crew. This shows the necessity and importance of the training for all the persons involved in the maritime transportation of goods on securing of cargo as stated by Capt.S.A. Ulin, Director of survey organization Swedish Association of Marine Underwriters:

" The modern and very effective door to door transport of goods is here to stay and I think the combined mode of transport will develop to more and more sophisticated solutions and all goods will be stowed and secured by the shipper or his forwarder. Therefore, there is no use standing here complaining about what is wrong and what has happened before. We must act and in many different ways. One way is to tackle the people of the industry, not only by information, but also by proper education and training".

However, the training can not be the same for all people, because of the different levels of the persons involved in goods transportation.

Therefore, the differentiation of two levels ( basic training for the workers and high level training for the cadets of

maritime academies) for this training will be a solution for solving the inequality of the levels. Additionally to these two categories of training, refreshing and updating courses can be useful for all levels.

## CHAPTER 6. BASIC TRAINING ON SAFE-STOWAGE AND SECURING OF CARGO AT THE LOWER LEVEL.

The cargo securing problem has to be considered in different points according to the ship designs and outfits. It is not the same problem for instance on Ro/Ro ships and on the conventional ships where the problem of securing is different. On Ro/Ro vessels, the problem has to be seen from two different points:

- the one is the securing of the trailers, containers trucks, ect;
- the other one is the cargo securing on top of flats and trucks.

Most of the expectations put into the modern transport technologies have been realized, but a very essential problem still remains: damage and loss. The principal cause of damage and loss is the misevaluation of transportation risks and the wrong procedures based thereon, such as:

- selecting wrong or deficient packing;
- selecting and using non- suitable transport modes;
- failures by wrong handling methods or procedures;
- inexpertized in stacking, stowing and securing of goods
- disregarding of static, dynamic, climatic, chemical or biological transport stresses etc.

An effective and economical, as well as a damage-free forwarding of goods can only be achieved when all those participating in the project exhibit the necessary knowledge and skills. This can only be reached by intensive and

oriented training.

## 6.1. People Involved in this Training and its Objectives.

### 6.1.1. The objectives of this training.

The main objectives which may be achieved by a better training are:

- avoidance of cargo damage or loss during the transport;
- achievement of more economical securing techniques;
- assurance of safety of life and cargo for the mode of transportation;
- increase of competitiveness and better service.

An important point to be considered by achieving those goals, is the existence of rules, regulations, recommendations and particularly the IMO's Code of Safe Practice for Cargo stowage and securing.

### 6.1.2. The involved personnel.

The transport chain today, consists of many single links and these links fit one into the other, although each link is a separate entity. It is necessary that the training is not restricted to single links, but should cover the total complex of the transport chain. Only through such complete training efforts can a substantial increase in the efficiency of forwarding be achieved. The range of the training measures must be oriented to the professional and personal conditions existing in the particular fields such as:

- ship board;
- dock side;
- industry side.

Even today, the problem of securing is a more shore-based job, the efficiency of the securing particularly when the ship is at sea depends on the crew, who according to the weather conditions must check or add or retighten the lashing

when it is needed. Therefore, it is worthwhile that they have a good basic training in order to act in the positive way. The largest part of this efficiency is a job of the shore-based people (dock stevedores and workers of industry). The dock side stevedores are the ones who secure the cargo on board the ship. They have to be skilled people in order to bring a substantial increase in the efficiency of cargo securing which can be able to reduce damage to cargo and its loss. Cargo has not only to be secured on board the ship, but by looking at the modern transportation system nowadays, (vehicle/trailer, container, pallets etc) on board container/Ro/Ro vessels, the goods have to be secured on the trailer, or vehicles by industry-side workers. As the working group SAGIT (Safety of Goods in Trailer) stated: "The sea voyage required much more in way of securing measures than the road transport. However, in order to establish a minimum requirement which would at least improve the prevailing situation also at sea, we informed the shippers that the Swedish Road Safety Office required by law that cargo in the interest of third parties, should be secured on the trailer in such a fashion that it was prevented from causing damage to persons or property on or along roads".

## 6.2. The Main Aspects of this Training.

### 6.2.1. Standardization of securing system.

Everyone is aware, that only a normalized technical transport system can be used world-wide. As stated by Capt. H. Stradt: "The International Maritime Organization (IMO) has come already to the conclusion that there is a need to improve standards of stowage and securing of cargo units and other entities in ships other than cellular container ships". A standardization of systems will enable a great normalization of a multitude of other aids and equipment, and additionally will reduce and simplify the number and complexity of operating steps.



The classification societies have their own sets of rules, and those within the industry are not always identical. The similarity between these sets of rules will bring an improvement in the securing system. Due to the similarity of those sets of rules and similar methods of handling and securing, the personnel undertaking the securing is accustomed to use similar operating and securing procedures, and thereby the loss or damage as a consequence of the cargo shifting, container or trailer breaking away will greatly be reduced.

However, when the wrong system is used or when a suitable system is not correctly applied a great deal of damage can occur, this is usually a result of the fact, that the personnel is not sufficiently qualified.

It is also the fact that there are no appropriate loading and securing regulations regarding the stowage procedures, the normalization and use of securing materials. The personnel must show then a great deal of initiative and knowledge to undertake these necessary procedures successfully.

Even rules and regulations can not lead to improvement when the people using there are not accustomed to them. Well trained personnel are in a position to control the implementation of such rules and regulations which is in any case essential.

#### **6.2.2. The need of skilled dock and industry workers for securing tasks.**

By speaking about cargo securing, the dockworkers or industry workers( who are used for the stowing and securing goods on trailer or in container) must understand all methods used to prevent the cargo against static and dynamic transport stresses such as:

- compact securing or compact load which is accomplished by stowage without gaps or through padding out of all gaps;
- individual securing which is the securing of

single pieces, larger consignment, and/or units. The most used methods are lashing, timber blocking, or a combination of both.

Obviously, the compact securing seemed to be easy, but a lot of mistakes could be made, leading to cargo damage or loss if some important aspects are not taken into consideration, for instance: weight of superimposed packages, lack of dunnage, residual materials from previous cargo, failures to keep stack straight, use of net, timber etc. In any case, a qualified stowage and securing of cargo will bring about a reduction of cargo securing expenditures, whether by direct or indirect savings of material in consequence of selecting a more favourable location or by more economical use of working hours.

#### 6.2.3. The particular characteristics of shore-based workers training.

Due to the constantly changing quantity and types of cargo, the different modes of transport and the types of traffic together with the different types of equipment and handling, it is not possible for the port authority to obtain specialistes for every area. A flexibility is necessary for stevedores in order to face those problems. A possible practical solution also to cope with those problems may be:

- \* A high standard specialization for the operation of particular equipment and the undertaking of constantly repeating work and also a key position in the efficiency of the port;
- \* For all functions, for which a high specialization is not required, but a general knowledge and application, a multipurpose dock-worker or skilled dock-worker may be trained in order to carry out a multitude of different types of tasks;
- \* Unskilled labour or those with lower level of qualification should be given a basic training so that they are in the position to understand the main ideas

so that the orders given to them have a meaning and the methods of working are apparent. This includes persons who undertake standard securing methods such as securing of containers, trailers and vehicles etc. As consequence the better trained and qualified employees are more stable, and the employers interest in the better qualified and more flexible persons. The Trade union is also interested in defending higher wages for the labour-workers. A higher training will not bring more productivity. This occurs only when a payment is involved.

#### 6.2.4. The particular characteristics of the ship's crew training.

Some years ago, there were more possibilities to avoid cargo damage or loss due to the fact that the ship's crew were more involved in the loading, securing and discharging operations such was the case of the cargo officer who was able to undertake, with the assistance of hatch-watchman, a safe control of the cargo. Also, the securing of cargo yesterday was better than today because the vessels of yesterday had a better seagoing capability and it was easier to understand cargo structure and more personnel and time were available. Today the situation is different due to rapid and more sophisticated development of the shipping and only a better training and distribution of information can help to counteract this change.

Due to the increase of ship's capacity, the loading and discharging speed of the ship in port, the employment of many working groups distributed in many loadind areas becomes necessary and prevents the ship's crew from having a clear overview of the operation. Only trained personnel are in the position to coordinate and undertake the necessary control functions for the safety of the vessel so that no consequential errors remain unidentified. In case of controlling container and Ro/Ro loads, the statistical check is often used, because of the speed of loading. Therefore, it

is most important for this task that a qualified eye is available to quickly and accurately discover a failure. Only a trained person is in a position to eliminate this failure in the best way or is able to give technical instructions for preventing such failure.

The change of the securing tasks to stevedores or cargo securing agencies can only be well achieved when the ship's crew is in a position to give clear and comprehensive instructions to them. These tasks can only be carried out technically and economically (by thinking of the shipowners) when the ship's crew is well trained and informed. [28]

### **6.3. Details of Training Program for Cargo Securing Personnel.**

#### **6.3.1. The detailed teaching syllabus.**

##### **6.3.1.1. Theoretical training.**

- .1 Basic knowledge of transport medias, goods and types of packing;
- .2 Basic knowledge about the use of friction as force for securing;
- .3 Basic knowledge about ships stability and their reaction in seas: the main different motions of ships which can be dangerous for cargo and ship such as rolling, pitching, heaving, vibration etc;
- .4 Basic knowledge about the stresses encountered by the vehicles during road or rail transport ( from factories to the port of shipment);
- .5 Knowledge about different cargo securing equipment such as: ropes, wires, chains, shackles, steel-strips, straps, belts, turnbuckles and other tensioning devices, lashing eyes, timber, wire-clips etc;
- .6 The elastic and plastic qualities related to the deformation of the materials, as well as the tensile strength are just as important and should

- be also handled;
- .7 Knowledge about possible thumb rules for daily use;
  - .8 Types of lashing in daily use and how they should properly be used;
  - .9 Basic lashing methods should be shown and their different advantages and disadvantages should be discussed;
  - .10 All elements used in the lashing systems e.g. lash-bars, twistlocks, bridge fittings, stockers etc and their correct use: are just as important;
  - .11 General theoretical knowledge in lashing techniques, such as: vertical and horizontal lashing system, the connection between pretensioning, and residual strength, homogeneity of lashing and the influence of the lashing angle to the effective forces.

#### 6.3.1.2. Practical training.

- .1 Safe use of tools, e.g. chain-saw, wire cutter;
- .2 Correct amount of lashing by using different materials of different strength and in different situations;
- .3 Building up of various types of timber blocking and other wooden constructions;
- .4 Securing simulation of diverse commodities differently stowed such as: cars, cases, coils, construction parts, cable-reels, crates, drums, pipes, spare-parts, machinery etc, loaded onto trailers, trucks, in containers in ship's holds, cargo shipped on deck etc;
- .5 The securing of the trailers, containers, chassis etc is to be taken.

#### 6.3.2. Guide-lines and organization of the training.

A training for cargo securing personnel should be organized under swome guide-lines such as:

- \* Determination of number of trainees: it would not be economical to run this kind of training without a large number of trainees, and also in some cases it will be advisable to use external institutes for the lessons;
- \* Choise of possible candidates: they can be from the field of able-bodied seamen, carpenters and similar wood working trades etc;
- \* Decide the teaching methods in general: the theory should be taken into account and should be made at least interesting for the participants.  
Complicated subjects must be broken down in different easier stages for the trainees. The use of slides, films, experiments is advisable to explain the subjects;
- \* Preparation of exrecises for practical lessons: the preparation for practical lessons must cover a wide range of daily work which the securing specialist could be confronted with. So that he can be familiarized with nearly all possible problems that could arise. The well trained person, when fully trained, should be able to work under his own responsibilities;
- \* Procuring the necessary tools, commodities, cargo securing media and equipment: enough different types of the necessary tools, materials, commodities or cargo must be at hand to guarantee that nearly all variations of securing methods can be effectively and sufficiently pratized or similated with the trainees as well as possible;
- \* The training system of skilled dock workers can last between 45 and 90 days this depends on the entrance level of the trainees( for instance, in the Port of Bremen Training Center, this lasts 45

to 70 days). But in the Port of Bremen Training Center, modification to the length and content of the courses is made to accommodate the requirements of the different trade groups. From the total training period at the Training Center, about 20 to 35 days are used to instruct on stowage and securing techniques.

#### **CHAPTER 7: HIGH LEVEL TRAINING FOR SHIP-OFFICERS AND MASTERS.**

Before introducing this chapter, which should be of great importance for the maritime academy syllabi, I would like to give a brief report on an accident, which happened on April 11, 1985.

" On April 11, 1985 on board a German coaster, on a voyage from Belfast to Le Havre a very serious accident happened. The vessel had loaded some heavy lifts lashed and secured by professional riggers before sailing. It is mentioned that, the crew retightened the bottlescrews when the weather got worse. But apparently they did not retighten the bulldog-clips. The wires were fastened with 3 bulldog-clips only to the ends of heavy container bottlescrews. In the heavy seaway, one of the heavy lifts started to move and the sailors had to go down to set additional lashing. One sailor was injured badly and died. The German Maritime Court has recommended in its decision: The vessel's command could not be able to calculate the arising stresses as well as the number of lashing and bottlescrews required. They only had available their own experiences in seamanship. The Court continues: Seamanschool, Nautical Highschools, and Labour Insurances are requested to develop simple rules and regulations which even mates and masters of smaller vessels are able to understand and to act accordingly. Some publications in special magazines, even if they are very good, cannot be replaced by proper instruction to those who are sailing the ships ". ( reported by Capt H. Stradt Marine Surveyor). This quotation is not only to introduce the

chapter, but also to point out the necessity of " High Level Training" in the maritime academy.

## 7.1.Theoretical Aspects of the Training.

### 7.1.1.General overviews.

- \* The cargo securing has been empirically done by most of seafarers who based their knowledges on previous experiences at sea, and by some experts( most of the time seafarers) who used also their sea experience.
- \* But in the last two decades, this problem has been mathematically approached by Classification Societies for standardized units such as containers, tanks etc.
- \* For few years, concerning the semi-standardized units( vehicles/trailers), some efforts have been made to approach the problem scientifically. It is the case of the report of MariTerm in 1983 on the "Securing of Road Trailers on board Ro/Ro ships".
- \* Finally, some experts( Professors H.Kaps and S.Kastner from Bremen Polytechnic, and Mr. P. Anderson from MariTerm-Sweden etc) are trying to approach the problem in a global manner that means to find some applicable solutions for non-standardized units.
- \* This has provided IMO the necessary punch for developing a new Code on securing of cargo( the statistics of accidents due to cargo shifting were also determinant for this IMO-decision.
- \* For these reasons, it becomes necessary and even compulsory to train the cadets in the maritime academies at the high level in order to give them the opportunity to be familiarized with those mathematical models with which they can be able to handle on board current problems posed by securing of cargo, to keep the IMO-spirit: " Safer shipping".

### 7.1.2.The model of the teaching syllabus.



- .1 Basic knowledge of the sea environment;
- .2 Knowledge of the different ship's motions in Ocean waves;
- .3 The typical motions affecting the securing of cargo. The accelerations caused by those motions;
- .4 Large motion acceleration;
- .5 The estimation of the risks of cargo movements;
- .6 Position of cargo with respect to turning center of motion;
- .7 The different assumption of external forces to cargo
- .8 The strength of the securing material;
- .9 The basic knowledge of safety factors;
- .10 The use of friction forces assecuring means;
- .11 Balance of forces and moments;
- .12 The analysis of the phenomenon of fatigue and sources of failures in lashing;
- .13 Distribution of operational stability, and measures for its improvement;
- .14 Practical handling of the ship in heavy weather.

### 7.1.3. Some comments on the different points of the syllabus.

\* to 1)

Brief study on the characteristics of a seaway and assumption to the seaway equation ( spectrum energie of the wave) as developed already in part two chapter 3 of this project. Estimation of the wind load on the superstructure of the ship ( as e.g. developed by R.W.F. Gould of the Royal Institution of Naval Architects in his booklet No.8 of Maritime Technology Monograph: "The Estimation of Wind load on Ship Superstructures"

The problem of weather routeing has to be discussed as it is done in part 3.2. of the chapter 3.

\* to 2)

A ship at sea has six modes of motions. The designation of these are: roll, pitch, yaw, sway, surge and heave. Above all, heave and pitch movements have to be emphasized as the most important, because of their magnitudes which are of great means to the strength of the hull beam. However, when speaking about cargo securing, the rolling as ship motion is the worst.

\* to 3)

The different accelerations generally speaking, due to the six movements can be divided on board the ship as follows: the transversal, the longitudinal and the vertical accelerations which are directed across, along and normal to the deck.

- The transversal acceleration is chiefly caused by roll, but also comes from yaw and sway motions;
- The longitudinal mainly from pitch, but also from surge and yaw movements;
- The vertical acceleration from heave and pitch, but also from roll motions.

Emphasis has to be put on the different approaches developed by some research papers such as: Safe Stowage and Securing of Cargo by (Professors H.Kaps and S.Kastner) and by Peter Andersson of MariTerm, to assess this difficult topic.

\* to 4)

The inevitable roll motion of a ship at sea can in its extremes result in either one of the following effects:

- capsizing at extreme roll with insufficient righting lever capability;
- large roll amplitude in a quick time sequence i.e. at a high roll motion frequency, leading to high motion accelerations acting on the cargo, which might end up with danger from capsizing

due to shifting of cargo.

It is well known, that measures to reduce the danger from capsizing by increasing the uprighting moment leads to larger roll accelerations, according to the simple formula:

$$(\ddot{\phi})_{\max} = \omega^2 * (\phi)_{\max} = \frac{g * GM}{(i_T)^2} * (\phi)_{\max}$$

where:

$(\ddot{\phi})_{\max}$  = roll acceleration

$(\phi)_{\max}$  = maximum amplitude

g = gravity acceleration

$(i_T)$  = roll radius of gyration

(From Prof. S.Kastner Bremen-Polytechnic) [13]

\* to 5)

The problem of risk estimation is an important factor for the determination of the material to be used for securing. This has already been discussed in the chapter 4 part 4.1 of this paper.

\* to 6)

The position of the cargo on board the ship must be given in ship's body fixed coordinates and independent of the loading condition of the ship. Its coordinates should preferably be given with respect to the aft-perpendicular (longitudinal coordinates e.g.  $X_a$ ), and with respect to the bottom keel (vertical coordinates e.g.  $Z_a$ ). With respect to the cargo, the mass centre unit considered should be used. (from Prof. S.Kastner in his Proposed framework for the calculation of lashing forces for practical use on board ship and action to be taking in heavy seas).

\* to 7)

Definition of forces acting on cargo:

- longitudinal force parallel to deck  $F_l$ ;
- transversal force parallel to deck  $F_t$ ;
- force vertical to deck  $F_v$ .

Different approaches have been developed to assess the problem of external forces to the cargo. The one developed in this paper is the one discussed by Professors H.Kaps and S.Kastner. There are also some other approaches which have been used for many years to assess the external forces to standardized units ( e.g.containers) by the classification societies. Another approach developed by experts working with Mr. P. Andersson in MariTerm was a mathematic model for calculation of Trailer lashing forces on board ship.

\* to 8)

The strength of the securing materials has been assessed by the Port of Bremen Training Center and extensively developed by Prof. H.Kaps and S.Kastner in their research paper. This study is important for the estimation of the use of lashing devices, and the difference between the breaking load given by the manufacturer and the maximum securing load (MSL) as it is named by Bremen Training, can be

recognized.

\* to 9)

The problem of safety factor has been already discussed in the chapter 4 part 4.3 of this project in which the assumption to the safety factor as developed by Prof. H.Kaps and S. Kastner, has been described. More details on this topic can be obtained in the research report written by P.Andersson on "Optimum Safety Factor For Securing Of Cargo On Board Ships".

\* to 10)

Friction forces as securing means have been already discussed in the chapter 4 part 4.2 of this paper as assessed by H.Kaps and S.Kastner. By teaching this part of the syllabus, the assumption on it done by some classification societies and by the experts of MariTerm has to be taken into account.

\* to 11)

Balance of forces and balance of moments are used to evaluate the necessary number of lashings. This has been assessed by H.Kaps and S.Kastner (as discussed in this paper), and also by classification societies and MariTerm. These various approaches must be taught in such training.

\* to 12)

Referring to chapter 5 part 5.2.3 of this project, the problem has been discussed by Mr. P.Andersson of MariTerm in his research report on "Safe Stowage and Securing of Cargo on board Ships". The sources of lashing failures have be investigated by H.Kaps and S.Kastner as developed in the chapter 5 part 5.2.1. of this paper.

\* to 13)

Referring to chapter 5 part 5.2.3 of this project, the problem as been discussed as it was assessed by Prof. H.Kaps and S.Kastner.

\* to 14)

Actual probability distributions of the operational stability can be found from the evaluation of ship log books.

However, it is not mandatory to take notes on the actual stability status of the ship. Thus operational stability remains within the practical experience of the ship master, but regular notes and evaluation according to an agreed "probability density for operational (GM)" are highly recommended. (Partly handled by Prof. S.Kastner in his booklet on "Operational Stability of Ships and Safe transport of Cargo").

#### 7.1.4. Some remarks about the teaching methods.

- Demonstrations are necessary to get the cadets being used to the topic. For this purpose, simulation can be in the practice, the theory must be based on many case studies or worked examples;
- Projection of transparencies, slides series even films and other visual and audio-visual teaching aids must be prepared well in advance;
- The training should have the aim that the student not only learns how to secure, but also why he has to do it;
- The use of practical exercises must be available to illustrate what the student has learnt during the theoretical lectures;
- The use of models and proven pattern will give more efficient results than only long theories;
- The analysis of some accidents which have happened in the last 20 years, will be helpful as support to

lecturers to emphasize the importance and need of a high level training in the maritime academies.

## 7.2. Practical Aspects of the Training.

### 7.2.1. General overviews.

- \* The cadet must know what materials or equipment are necessary to achieve a good securing according to his theoretical lectures;
- \* He has to be aware of the different materials which vary according to the cargo units to be secured and the securing methods used;
- \* The different lashing methods which are currently used on board the different types of vessels;
- \* The practical use of the different securing materials in order to get the maximum strength of the lashing and a good physical efficiency of the lashing;
- \* The different kind of lashings and their lashing angles:
  - horizontal lashing when it has to be used and its aim;
  - vertical lashing when it has to be avoided and its aim.
- \* Practical training on board vessel when it is possible to make the future junior officer more familiarized with the problem of cargo securing;
- \* The minimum attention which has to be given by using all these materials e.g. the clips as Capt. Stradt has pointed out in his report on the "Bulldog- clips: Standards are needed";
- \* Why and how particular attention has to be given to deck cargo and the recommendations of IMO in the "Code of Timber Transport as Deck Cargo". Some recommendations have also been given by Capt. J.R. Knott in his booklet on "Lashing and Securing of Deck Cargoes"

\* The survey and the maintenance of securing devices or equipment is important, because the efficiency of the lashing depends on the conditions of the materials.

#### 7.2.2. Some case studies developed as examples by Bremen Training Center.

Case No.1. Goods loaded in containers deteriorate, rust, get mouldy or damaged by direct contact with water, because too wet timber or with snow or frosted are used as securing materials to increase friction forces, and they are not removed before stuffing the containers. Only well trained personnel is able to carry out all essential precautionary measures with regard to the preparation of stowage areas or holds.

Case No.2. The shipment of large sheet metal packages of high weight. The large consignment of sheet metal packages of high weight is to be stowed between the shell plate and a longitudinal bulkhead. The dimensions of the packages do not allow an absolutely compact load.

Non-skilled stevedores will possibly stow the packages in one block, leaving the gap either at the shell plating or at the longitudinal bulkhead's side. A timber blocking in this case must be based on the full cargo weight and will be double the strength of using a stowage method leaving the gap in the middle of the consignment. The favourable method is providing equivalent securing by half cost.

Qualified personnel will not only realize the relation between stowage and cargo securing expenditures, they also will bear in mind other important aspects: using dunnage, timber plank or square wood between tiers which not only will ease the putting of the packages, while loading or discharging by means of stevedoring gear and forklift, but also the higher friction will guarantee more security when using the same amount of timber for the blocking.



FIG. 4,5 and 6 : Stowing and Securing of Metal Sheet Packages

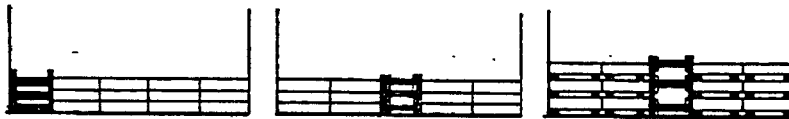

Case No.3. A larger consignment of drums shipped on deck is used as an example:

Time-wasting fixing of wires, nets and other securing materials under narrow conditions can be avoided, if these securing aids are fixed to the ship's deck and thrown over the rail before loading operation starts.

Case No.4. The homogeneity of securing materials. Regarding the economy of safe cargo, the homogeneity of securing materials is very significant.

A cargo is to be said homogeneously secured, if the working load of all lashings, timber blockings and other elements are adjusted to each other and in proportion to the calculated forces and determined safety factors.

FIG. 7: Inhomogeneous Lashings and inhomogeneous secured

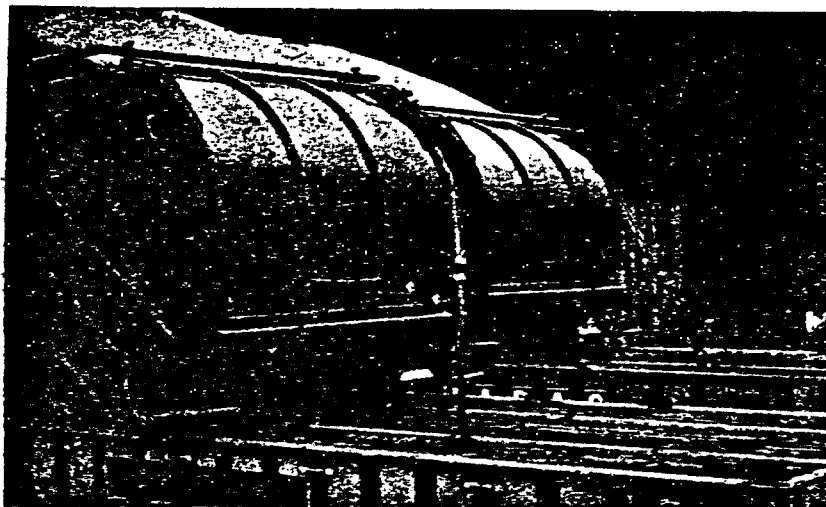

The above shown securing method is absolutely inhomogeneous. By expert use of the wires, turnbuckles, wire-clips and the shown shackles a working load of nearly 10tons could have been obtained. Using a wrong number of clips in a wrong way reduces the working load to less than 50% of the achieved rate. The flat's lashing eyes have a breaking strength of nearly 5 tons, their working load should be calculated within the range of 3 tons, because they will deform at nearly 60% of their breaking strength. The weakest elements in the total system are the handles of the commodity to which the lashings are fixed. They may have a breaking strength of 1-2 tons, and their deformation will start considerably earlier. When preparing a homogeneous lashing, all these facts would have been taken into consideration by trained personnel, and they would have come to an economical solution without wasting material and time.

### 7.3. Some Benefits of the Training and some Recommendations.

- \* This combination of both (theoretical and practical) training will enable the junior officer to fulfill his task as supervisor by checking with basic knowledge the job done by the shore-lashing gang, and to decide if additional lashings are needed once the vessel is en route, and the weather conditions are becoming worse.
- \* Also after some time of sea experience, the junior officer with this knowledge will be in the position to give some constructive criticisms on the current systems for their future improvement in order to avoid accidents generally due to inefficiency of some securing systems.

- \* The training of cadets in maritime academies on safe stowage and securing of cargo can not be at all the time possible without research center in the various maritime academies. Therefore, it becomes an urgent necessity for the shipping industry to help the maritime academies to keep up more research in this field in order to achieve the slogan of IMO: "Cleaner Oceans and Safer Shipping".
- \* It can be useful to organize in the maritime academies forums for having discussion between the cadets and some senior officers ( in function or not), in order to give the opportunity to the former to share the experiences gathered by the latter on this topic during their seetime.

#### CHAPTER 8 : REFRESHER AND UPDATING COURSE.

As it was stated by the Secretary General of the International Maritime Organization (IMO), I would like to introduce this chapter by a part of his statement. "Since its inception the International Maritime Organization has recognized the importance of human resources in the development of the maritime industry:

Following the earlier adoption of the International Convention on Standards of Training, Certification and Watchkeeping for Seafarers, 1978, a number of IMO Member Governments had suggested that IMO should develop model training courses to assist in the implementation of the Convention and in achieving a more rapid transfer of information and skills regarding new developments in maritime technology.

In addition, it was appreciated that a comprehensive set of short model courses in various fields of maritime training would supplement the instruction provided by maritime academies and allow administrators and technical specialists already employed in maritime administrations, ports and shipping companies to improve their knowledge and

skills in certain specialized fields."

This statement of the Secretary General of IMO explains well the need of a refreshing and updating course in one of these specialized fields: the securing of cargo.

#### 8.1. The Need of the Refresher and Updating Course.

- Since the lack of knowledge in this subject is spread over all, dock personnel, industry workers, seafarers at all levels, adequate training would require different courses with different contents for the various levels of employees.

- Ship's masters and officers as well as the shipping management should be educated and informed, because the ships of today require a new kind of seamanship.

In particular:

- . disregard to weather routing;
- . full speed without any regard to weather conditions because the ship owner wants his master to keep the schedule;
- . insufficient regard to the stability characteristics.

All these points often lead to damage or loss of cargo, ship and life.

- The training of a company's own personnel is essential to prevent claims and keep the company competitive.

But very limited improvements can be achieved, if only isolated training is carried out. Worldwide improvements can only be obtained by joint efforts to reduce cargo damage and losses, that means especially by organizing an adequate training not only in the own company, but also with other companies at many levels in order to gain more improvements.

- Within the exporting countries, a real and urgent need in training is extremely necessary for firms whose personnel work outside the seaports, but are responsible for securing loading of barges,

containers, trailers, flats etc, which must be transported overseas, and they can not estimate the risks of cargo shifting at sea.

## 6.2. Detailed Teaching Syllabus.

### 6.2.1. Theoretical aspects of this training.

#### .1 Common for all levels.

- \* State the necessity of securing cargoes in terms of
  - . safety of the ship;
  - . prevention of damage to cargo;
  - . prevention of loss overboard, thereby endangering the environment:
  
- \* Explain that one means of securing cargo is correct stowage:
  - . full cargoes will not shift;
  - . stowage across the full width of the ship will prevent shifting through rolling;
  - . Securing the exposed athwartship face of a stow will prevent shifting through pitching and heaving;
  - . stowage of steel directly on steel facilitates sliding and must be avoided;
  - . list securing materials as timber, stanchions, wires and clips, chains, nets, turnbuckles metal straps and etc;
- \* State the importance of having lashing points of adequate strength:
  - . on the cargo;
  - . on the ship's structure
- \* The reduction of friction
- \* Homogeneity of cargo lashing strength.

#### .2 Additionally for ship's masters and mates.

- \* For ship's masters and mates and shipping managers,

(as the Bremen Polytechnic, Department of Nautical Studies has started to organize), an updating course is needed in the area of cargo securing and stability. This will cover:

- . particulars of ship' motions in the sea;
- . handling of ships in heavy seas, in order to avoid resonance;
- . external forces on cargo;
- . securing of cargo, calculations and tests on ship-stability;
- . reduction of stability and accidents due to loss of stability;
- . the failure in the lashing and the problem of fatigue in lashing.

\* Measures to ensure safe transport without damage to ship and cargo can be divided into two:

- . reducing of loads acting on cargo achieved by ship design, operation, stowage, ballasting and etc;
- . dealing with the inevitable loads action on the cargo at sea from the environment by securing the cargo.

N.B. This is necessary and important, because many of the capsizing incidents, damage by heavy weather may be attributed to poor stowage or cargo securing measures or as an error on the part of the ship's management.

#### 8.2.2. Practical aspects of this training.

\* Emphasis has to be put on the practical use of the securing devices:

- the strength of the material and its breaking load;
- the physical efficiency of the lashing arrangement;

\* The appropriate types of securing devices for the different kinds of cargoes;

- \* The practical use of such materials in order to have efficient lashing arrangements ( for instance the right way to put bulldog-clips on the wires, as Capt.H.Stradt has stated about the bulldog-clips: "The quality and stability of each lashing wire connection is only as good as the kind of assembling and the number and pressure of bulldog-clips");
- \* The crew on board has to know that, if the lashings are getting slack, the main reason for it is that wires slip through the clips;
- \* By using the wire clips, which are most of the time new and dry, they must be used with greased threads which will increase the pressure on the wire, consequently the nut of the wire;
- \* How to increase the friction between surfaces through dunnage, plywood, rubber, timber etc;
- \* Failure in the lashing system and how to avoid it;
- \* Practical aspects of different securing methods:
  - in case of standardized units;
  - in case of semi-standardized units;
  - in case of non-standardized units;
- \* When and where horizontal or vertical lashing has to be used;
- \* For ship's crew, the maintenance of securing devices on board, and the regular survey of their life-time;
- \* For ship's masters and mates the practical measures to avoid resonance ( general steps to meet in such circumstances developed by Prof. S.Kastner from Bremen Polytechnic)
- \* Action to be taken when cargo has shifted for ship board management:
  - alterations of course to reduce accelerations;
  - reductions of speed to reduce accelerations

and vibrations;

- monitoring the integrity of the ship;
- restowing or resecuring the cargo and where possible increasing the friction;
- diversion of route in order to seek shelter or improved weather and sea conditions;
- tank ballasting or deballasting operations should be considered only if the ship has adequate stability.

N.B. All these actions are part of the IMO recommendations in the Code of Safe Practice for Stowage and Securing (Annex 2).

### 8.3. Some Important Points of the Training-Program.

#### 8.3.1. The organization of the training.

\* The different groups concerned:

The categories of employees who can be involved in this training may be considered under four(4) groups

- .1 the shipping management ( senior and middle management);
- .2 dock workers ( lashing gangs and some special-purpose personnel);
- .3 industry workers ( are people who secure the cargo in containers or on trailer);
- .4 the seafarers ( ratings, ship's officers and masters).

\* Organization of the training at each level.

. to 1)

The shipping management is responsible for a wide area. They can not be expected to know all technical details, but require sufficient consciousness of the involved dangers, so that the introduction of appropriate and adequate safety measures are initiated. A theoretical



training in form of a short seminar would be suitable. The duration may be 2 or 3 days. The principal approach will be a seminar with lectures on theoretical aspects, question period panel discussion and some case studies.

. to 2 and 3)

As the job of securing of cargo has become a shore-based job, the largest group of personnel requiring securing training are the dock workers and industry workers. A very basic awareness training has to enable them to achieve a safe stowage and securing of cargo. Their training should be repeated from time to time to serve as a reminder. The duration may be one week (5 days) during which, 2 days can be allocated for basic theoretical aspects and 3 days on the practical aspects. The emphasis must be put on the practical use of securing devices and the different methods of securing the use of the friction, and an adequate application of lashing etc.

. to 4)

For the ratings, the training will be the same as the one of the dock workers. The training of ship's officers and masters, covering all the theoretical and practical aspects, must be scheduled for one week.

#### 8.3.2. Some recommendations regarding the training.

- \* The refreshing and updating training would be of an extended duration and it needs to be updated.
- \* Attendance of special events (seminars, symposia etc) should be promoted. Particularly by making shipowners aware on the problem of cargo securing in order to allow them to take more care of this matter by giving enough time for the securing of cargo before the departure of the ship. Films on capsizing experiments are necessary for this purpose and some tests of models in towing-tanks.

- \* Sample and evaluate experience; accidents must be considered.
- \* Use of observation chart on severe ship's motions and extreme lashing forces as proposed by Prof. S.Kastner (See separate sheet).
- \* Case studies with discussion or projection of slides on the reconstruction of the cases if available.
- \* Teaching techniques:
  - lectures with selected audio-visual teaching aids, such as: projections of slides, films etc;
  - Evaluation through written examination for the personnel of groups 2, 3, 4 with issue of certificate.

## CONCLUSION.

Heavy weather will always arise and possibly cause damage and losses. However, it is reasonable to believe that the incidents of losses could be greatly reduced by well designed, properly implemented stowage and securing systems.

Damage as a result of the goods moving in the means of transport (e.g. containers, barges, vehicles, etc) constitutes however, a serious problem in maritime transport today, and has involved all parties concerned (operators, shippers, shipowners, marine underwriters, etc) in heavy financial way.

Maritime commerce has always been considered as a most tradition-bound part of economic trade, but has undergone great transformations during the last decades.

With the emerging of new methods of transport (containers, barges, vehicles, etc), conventional handling of goods on the jetty and in the vessel's holds ceased on many routes. The workload which in the past had been carried out on board and in the vessel's hold was transferred to the terminals and industries. These new methods of transport had however, not succeeded in eliminating damage to the goods in the way one might have expected. Instead, the extent of the damage has in many respects grown worse. The reason for this is largely insufficient techniques when consolidating and securing the goods in the means of transport.

Of all the problems associated with the safety of Ro/Ro ships perhaps the one which gives most concern is that of cargo stowage and security, i.e. the security of vehicles and the goods in containers and other units carried on Ro/Ro trailers.

Securing is very much a consequence of stowage. A tight stow within a restricted compartment between rigid steel structures does not need any lashing at all.

Several Classification Societies have published rules for container securing arrangements in both cellular and non-

cellular ships. As stated by the Chairman of Lloyd's Register in his Review of 1986, "the prime purpose of the Classification Societies is to enhance the safety of life and property both at sea and on land". But the approaches used by the Classification Societies are isolated and a need of international standardized approaches is urged for the maritime industry. The objective of this standardization, one cannot repeat it too often, is safety; safety of the cargo, of the ship, and of the personnel operating the system.

A safe transportation of cargo, a proper stowage and securing of cargo will be helpful for the achievement of this aim. Safe Stowage and Securing of cargo can be summarized in three levels of standardization:

- the standardized stowage and securing system;
- the semi-standardized stowage and securing;
- the non-standardized stowage and securing.

According to the International Maritime Organization (IMO) "Code of Safe Practice for Cargo Stowage and Securing", the main principles on which the safe stowage and securing of cargo must be based are:

- \* suitability of cargo for transport;
- \* cargo distribution;
- \* cargo securing arrangements;
- \* residual strength after wear and tear;
- \* friction forces;
- \* shipboard supervision;
- \* entering enclosed spaces
- \* general elements to be considered by the master;
- \* cargo stowage and securing certificate.

The procedure by which these principles can be carried out is in four steps as summarized in the attached diagram (See the diagram on separate sheet) as follows:

- 1.- The vessel designs and outfits together with the cargo categories which the vessels have to carry;
- 2.- Cargo securing calculations which include the environmental system, the technical aspects of

system and the cargo securing material;

- 3.- The international and national legislation (ILO/IMO guidelines, IMO-Code of Safe Practice for Cargo Stowage and Securing, and some national regulations relating to this field);
- 4.- Finally, the training of the personnel involved in the field of securing of cargo.

\* to 1.

The vessel's designs and outfits must be appropriate to the category of cargo they are supposed to carry. The basic design would have to take into account all the aspects of the cargo to be carried in order to provide the ship with suitable securing arrangements at the building stage. This will enable a proper stowage and securing of the cargo as it would be expected to encounter the external forces which can arise during the voyage.

\* to 2.

The cargo securing calculations are the most important element of the whole process. An easy approach as suggested in the IMO-Code of Safe Practice for Cargo Stowage and Securing and also in this project can be seen as a standardized approach for these calculations, particularly in the case of semi-standardized and non standardized cargoes. As already mentioned in the Introduction, this will help to release the isolated approaches of Classification Societies and national regulations. These calculations which should be included in the "Cargo Securing Manual", can be helpful to the master or the chief officer who would like to control the securing arrangements of the cargo on board his ship.

\* to 3.

International Organizations such as ILO (International Labour Organization) and IMO (International Maritime Organization) have presented common guidelines on the Safe

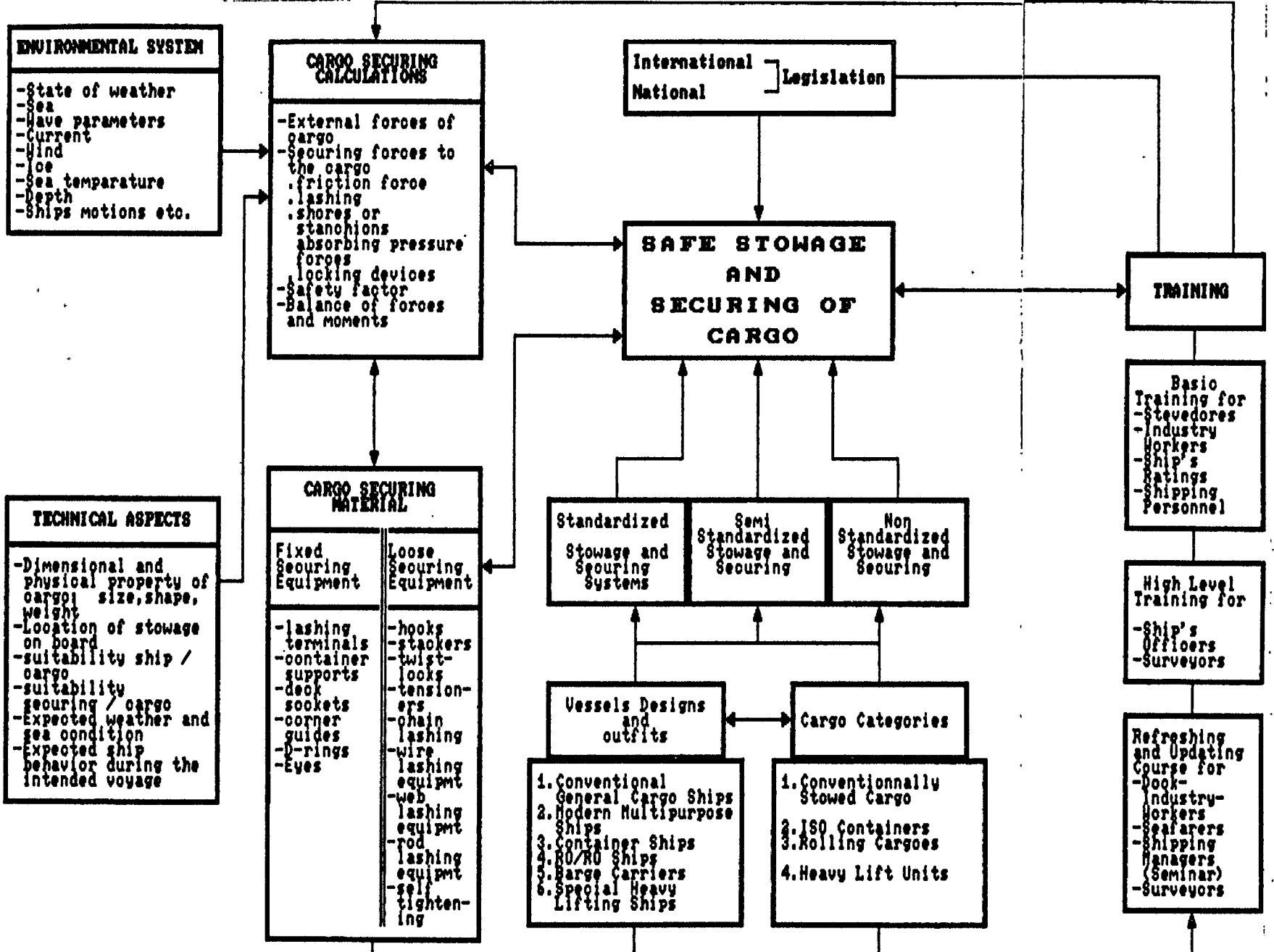

Stowage and Securing of Cargoes in Containers and Vehicles.  
(MSC-Cir.383, January 1985).

Especially, within IMO, the Maritime Safety Committee has, through its Sub-Committee on Containers and Cargoes, developed a "Code of Safe Practice for Cargo Stowage and Securing" which comes out first as MSC-Circular N.530, before its adoption by the IMO-General Assembly in Autumn 1991. The purpose of this Code, as it has been already stated in this project, is to provide an international standard to promote the safe stowage and securing of cargo by:

- drawing the attention of shipowners and ship operators to the need to ensure that the ship is suitable for its intended purpose;
- providing advice to ensure that the ship is equipped with proper cargo securing means;
- providing general advice concerning the proper stowage and securing of cargoes to minimize the risks to ship and personnel;
- providing specific advice on those cargoes which are known to create difficulties and hazards with regard to their stowage and securing;
- advising on actions which may be taken in heavy sea conditions;
- advising on actions which may be taken to remedy the effects of cargo shifting.

It should be borne in mind that the master is responsible for the safe conduct of the voyage and the safety of the ship, its crew and its cargo.

The basic principles of the code are that cargo should be stowed in such a way that safety of the ship is not put at risk by the cargo shifting.

In addition to all these purposes and principles, the code requests a "Cargo Stowage and Securing Certificate" which will be issued by the shipper for goods on vehicle, trailers and in containers. (See in Appendices the example of this certificate).

\* to 4.

Finally, no matter how sophisticated the equipment or how refined the operating procedures, safety in the end depends on people. It is generally accepted that the sophistication of Ro/Ro ships require highly trained and qualified crew to handle them in a proper and safe way.

IMO recognizes that the vast majority of maritime accidents is due to human error and it has been concentrating for many years on the improvement of crew standards. The entry into force on 28 April 1984 of the 1978 STCW-Convention (International Convention on Standards of Training, Certification and Watchkeeping for Seafarers), and its worldwide implementation has made a considerable impact in the reduction of maritime accidents.

Coming back to the Safe Stowage and Securing of Cargo, many persons will rely on the skill of the person packing and securing goods into the containers or vehicle (road vehicle drivers, rail workers, dock workers, ship's crew and passengers on board, cargo underwriters, shipowners, etc). All may be at risk from a poorly packed container or vehicle, in particular one that is carrying dangerous goods.

Speaking about cargo securing, the dock workers, the industry workers, ship's crew and shipping personnel (who are involved in the stowing and securing of cargo on trailers, in containers or in barges, on ships, etc), must understand all methods used to prevent the cargo against any movement (sliding, tipping etc) during its shipment. One way to get these people understanding the safe stowage and securing of cargo is to provide them not only with information, but also with proper education and training.

According to the attached diagram, this training which is the last element of the chain representing the Safe Stowage and Securing of Cargo, can be seen on three levels:

- the basic training for stevedores, industry workers, ship's ratings and shipping personnel;



- the high level training for ship's officers and surveyors (who are mostly used by the marine underwriters);
- and finally, the refresher and updating courses for dock and industry workers, seafarers, shipping managers and surveyors.

Apart from adequate training, the provision of proper advice is an essential step also towards achieving the well known slogan of IMO: "Cleaner Oceans and Safer Shipping". The adoption and the implementation of the "Code of Safe Practice for Cargo and Securing will contribute perhaps as well to clarify the stated discrepancies in the different lashing rules since it is most important to provide manufacturers and shipowners with clear regulations in order to guarantee safe and operational lashing and securing. This of course as well will permit development of new optimum systems, always required to improve ship's safety and economy in operation.

Finally, a good computer program which can properly combine the two (stowage and securing), not only for standardized units (such as containers), but for all kinds of cargoes, will be advisable and possibly the topic for a next research paper.

APPENDIX

Example

[Cargo stowage and securing certificate

Vehicle No. ....  
Place of loading .....  
Date of loading .....  
Commodity(ies) .....

I hereby certify that the cargo on the above-mentioned vehicle has been stowed and secured in accordance with the IMO/ILO Guidelines for packing cargo in freight containers or vehicles.

Name of Signatory .....  
Status .....  
Place ..... Date .....  
Signature on behalf of Shipper .....

Remarks: .....  
.....  
.....  
.....  
.....

## CODE OF SAFE PRACTICE

9. Observation chart  
on severe ship motion and extreme lashing forces

During voyages, ship masters are advised to take notes on extreme events regarding the safety of ship and cargo. However, taking notes is not mandatory, but highly recommended, in order to advance experience on the behaviour of ship and cargo.

Notes should be taken according to the following form:

NAME OF SHIP ----- SHIP TYPE -----

0 No. of observation	
1 date/time of day	
2 route/position of ship environment:	15 type of cargo & lashing
3 wave height observed	16 special lashing operation
4 wave period observed	17 cargo behaviour
5 heading ship-waves (0 following, 90 deg.stb. beam, 180 head sea, 270 port beam)	ship handling measures:
6 wind /Bft/	18 change heading
7 wind direction	19 " speed
8 duration of extreme events	20 " ballast
ship parameters:	21 " others
9 GM /meters/	22 stabilizers
10 $\phi$ /degrees/	23 remarks
11 $\theta$ /degrees/	24 graphical plot of observed $\phi$ versus GM
12 $T_{\phi}$ /secs/	(all observations within one year in one single graph, preferably 1 m GM = 5 cm paper 10 degr = 2 cm paper)
13 $T_{\theta}$ /secs/	
14 $a_L, a_T, a_V$ /m $\frac{m}{s^2}$ / if available	

ANNEX 3

APPENDIX 1

Figure 1:

Method A

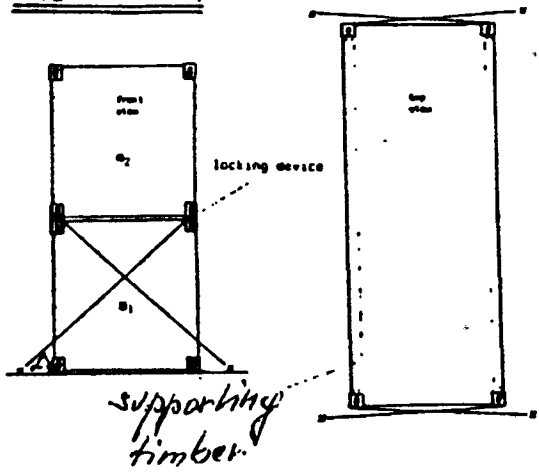

Method B

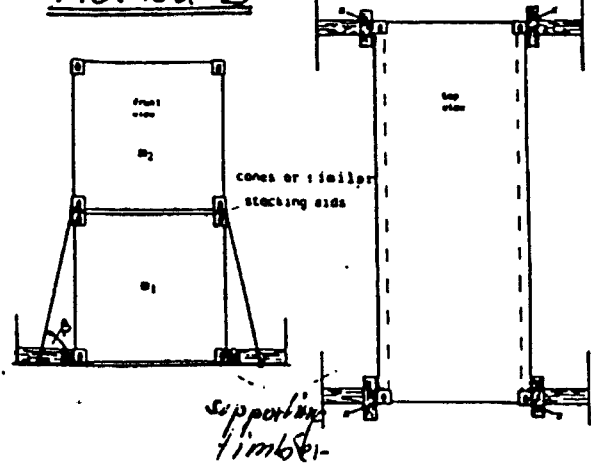

Method C

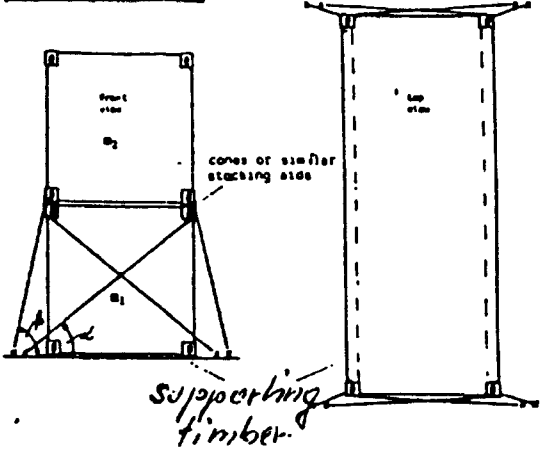
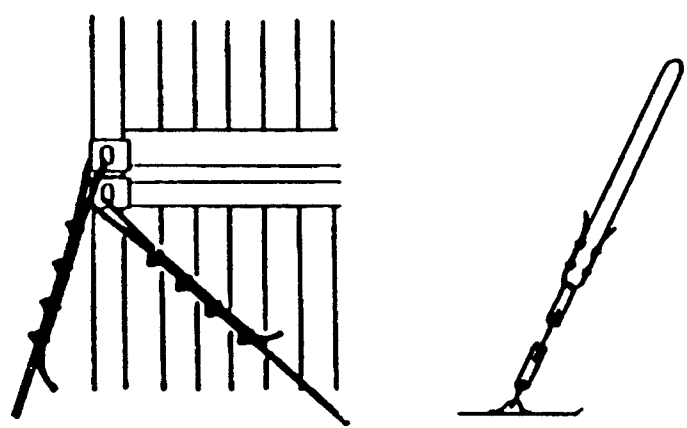

Figure 2

fastening of wire lashings to corner fittings;  
correct setting and number of wire clips;  
alternative constructions of wire lashings



PENDIX 2

Fig. 1  $\alpha_1$  - Favourable angle against sliding  
 $\alpha_2$  - Favourable angle against tipping

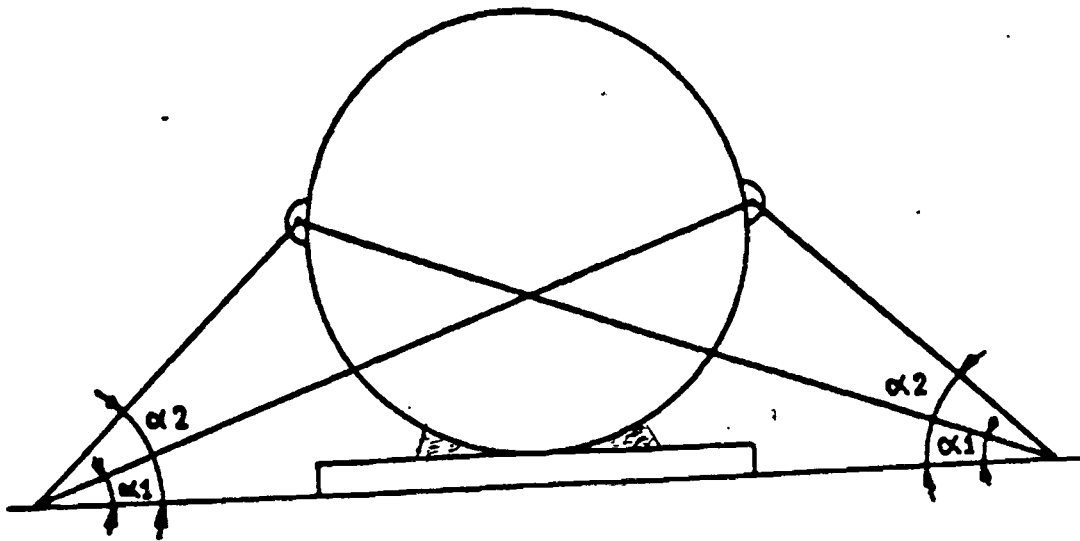
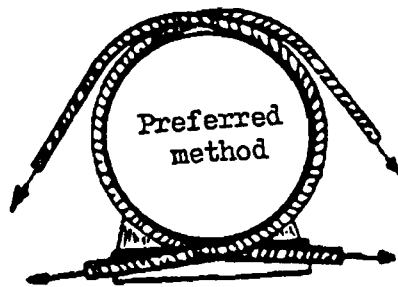

Fig. 2



APPENDIX 5

Figure 1: Lashing angles

$\alpha_1$  = favourable angle against sliding  
 $\alpha_2$  = favourable angle against tipping

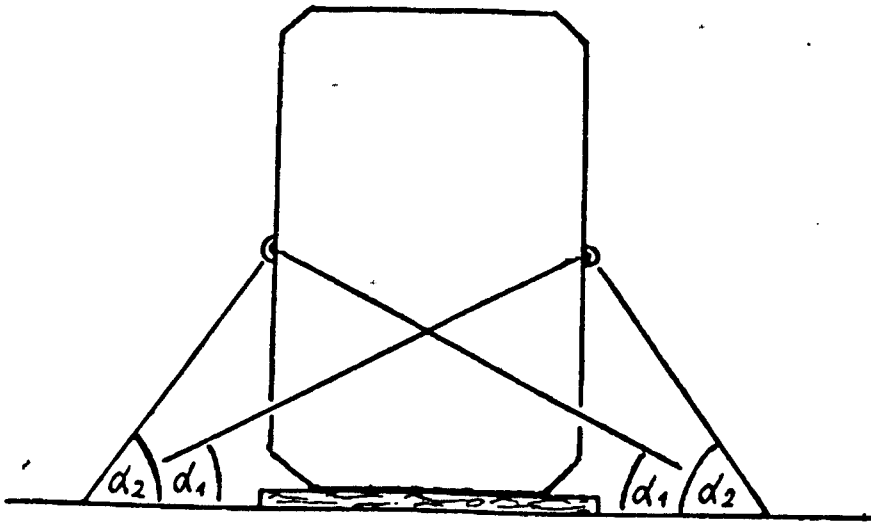
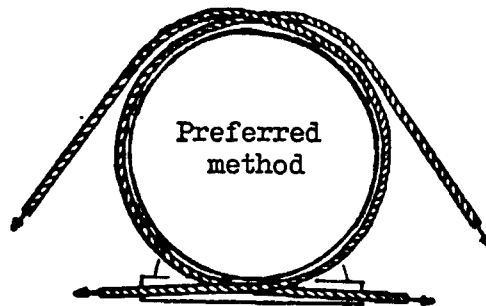

Figure 2: Principles of securing heavy items which have no securing points



APPENDIX 6

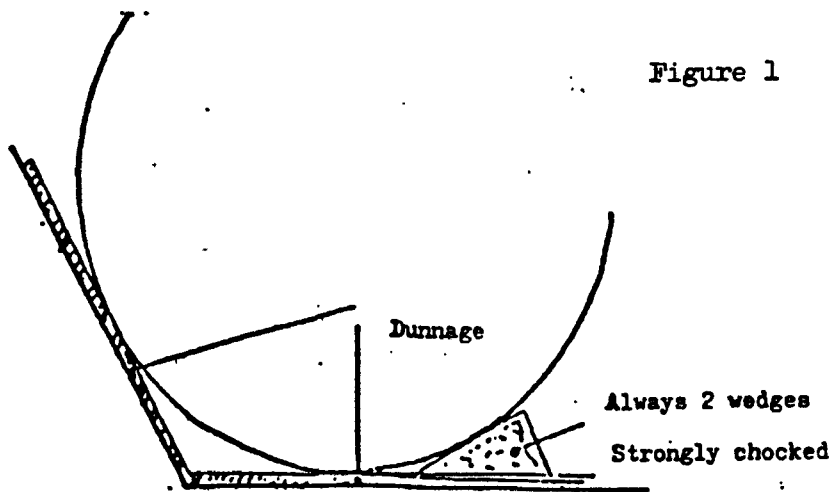

Figure 2:  
Locking coils

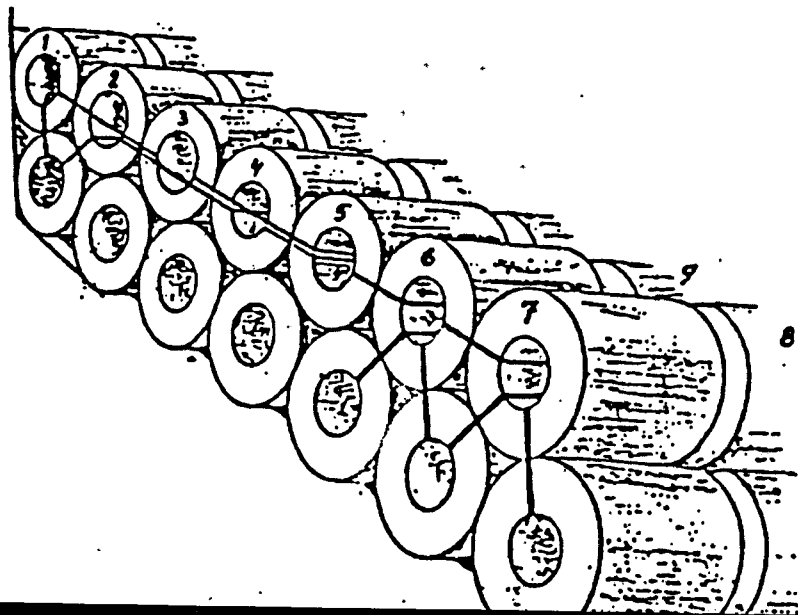
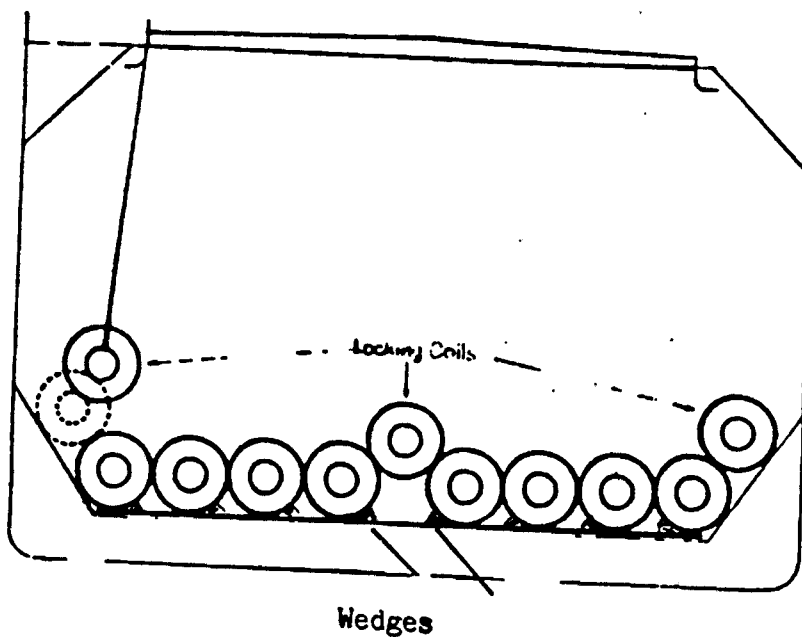

Fig. 3

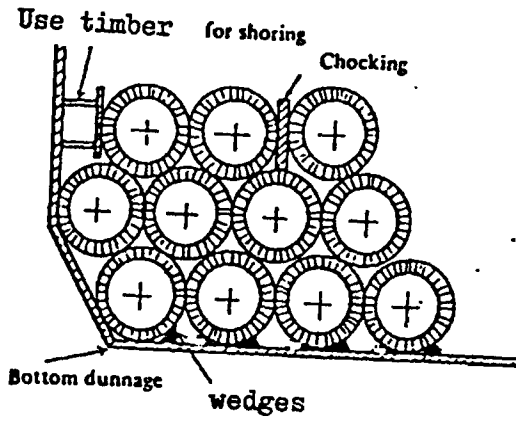

Fig. 4

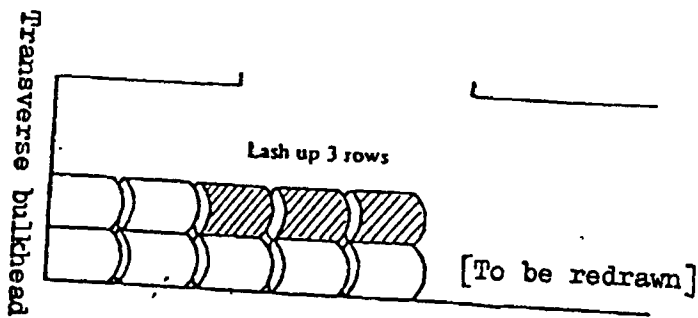

Fig. 5

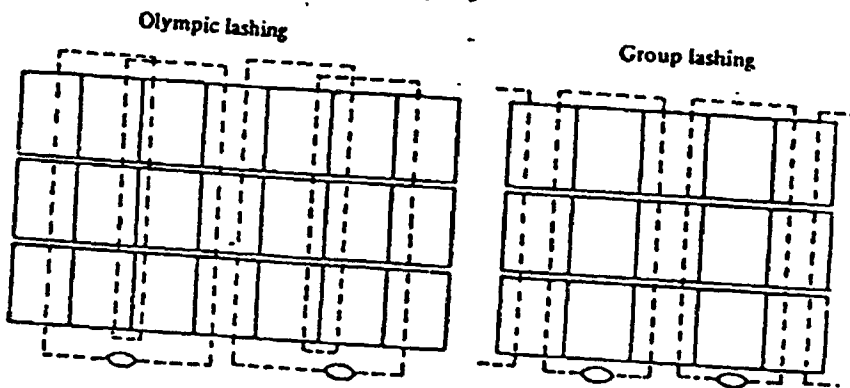



Fig. 6

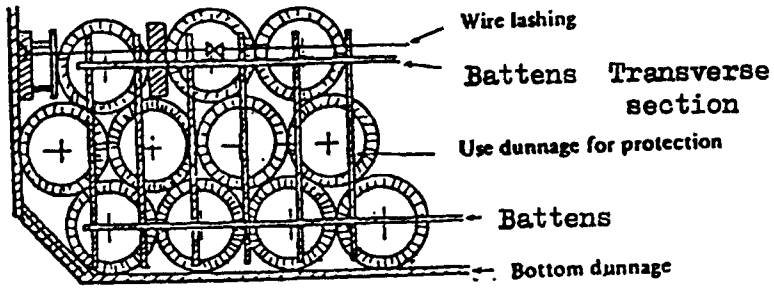
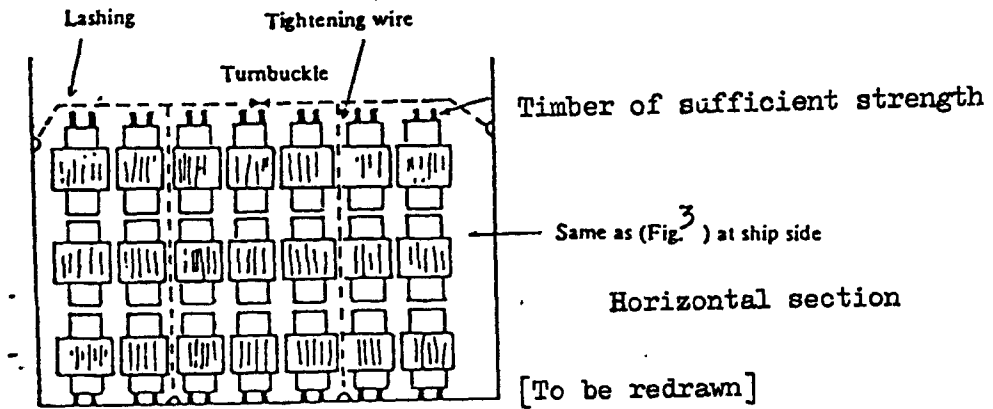
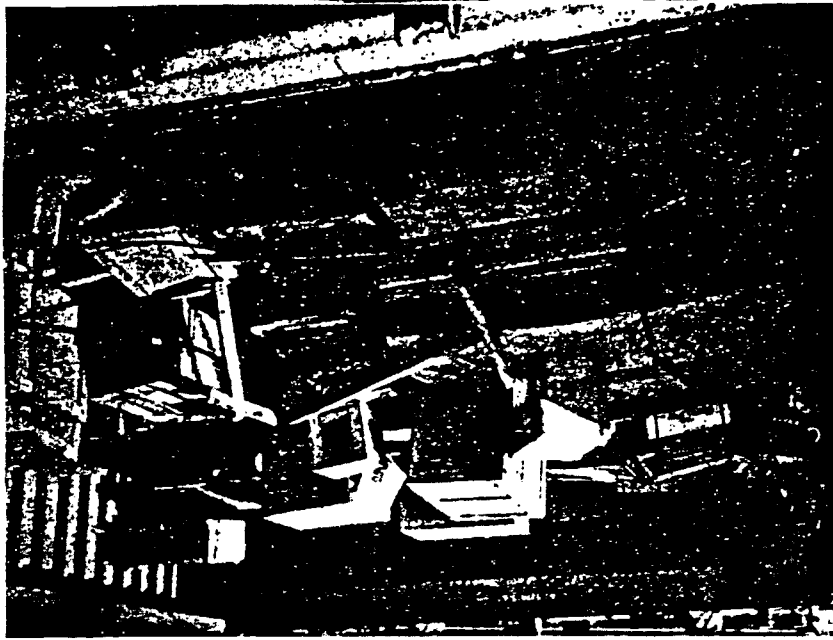
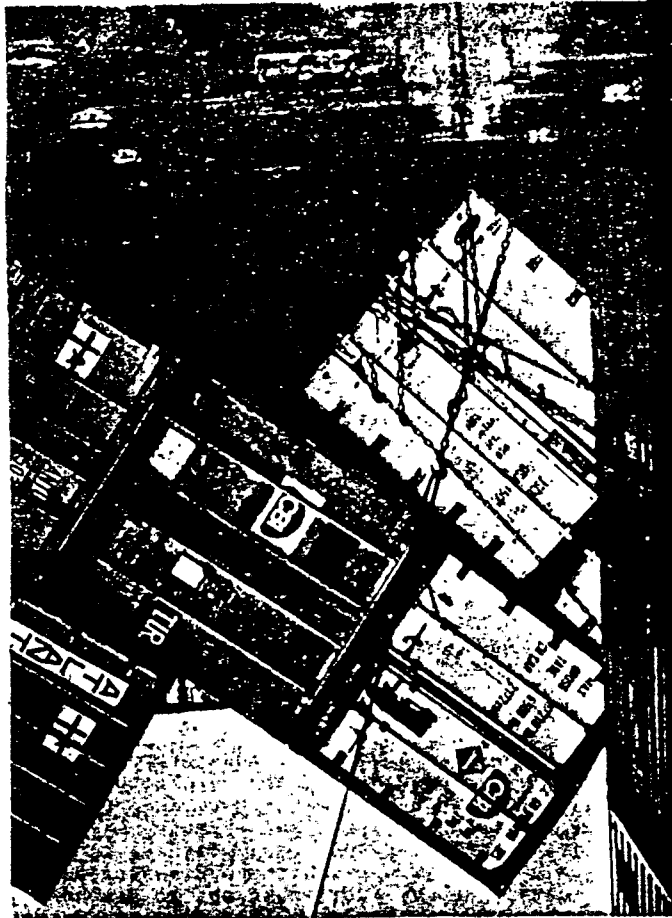

Fig. 7





Lash-barge - non-professional stowed and secured cargo



Severe Damage by Using Inadequate Securing Systems

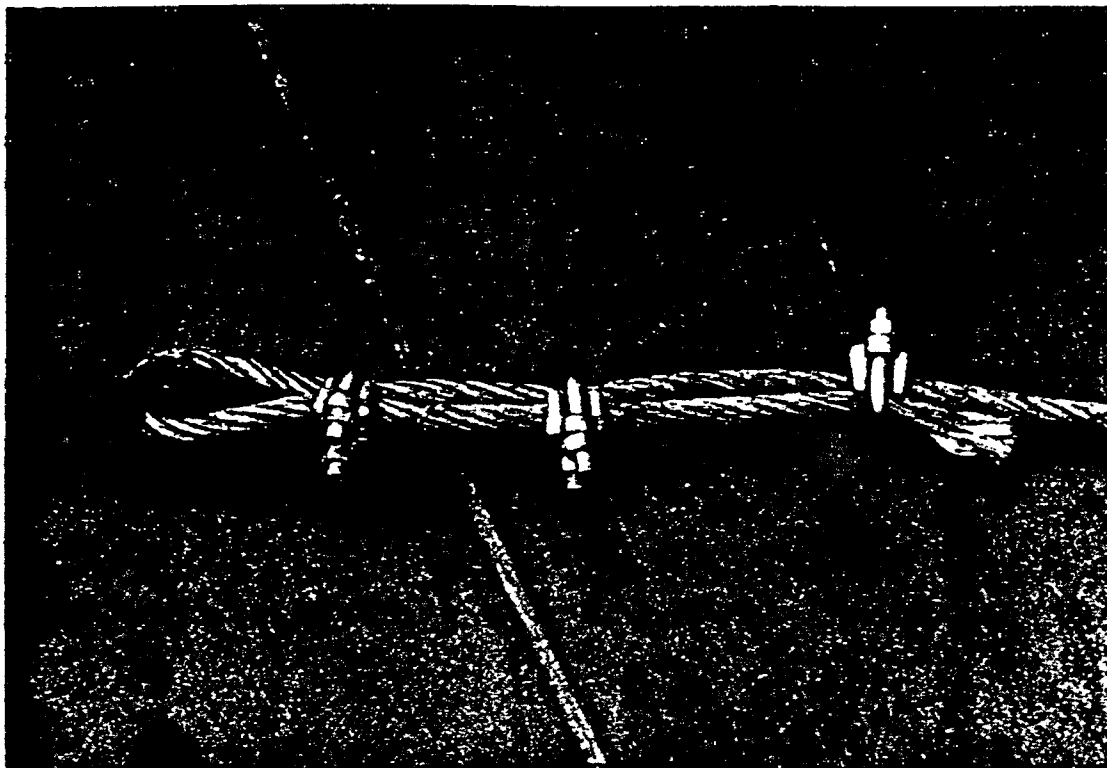

ix.

The first two grips are the right distance apart, but applied the wrong way round; the third grip is the correct way round but too far from the second grip and is attempting to clamp wire which is opening up at the non-whipped cut end. Slippage will occur suddenly at loads in the 2 tonne range.

x.

An acceptable method of creating a loop or strop in 16mm wire using four bulldog grips at each cut end, all applied with the bridges on the two "working" parts of the system. This arrangement will hold to the full break load of the wire.

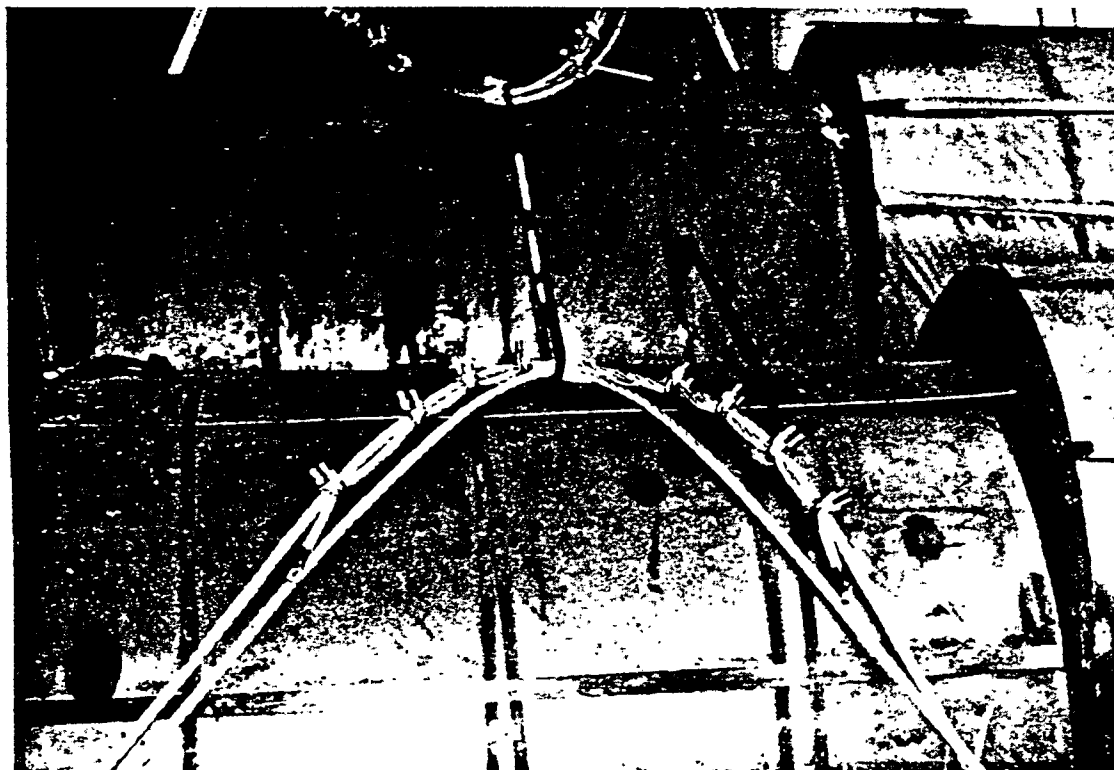

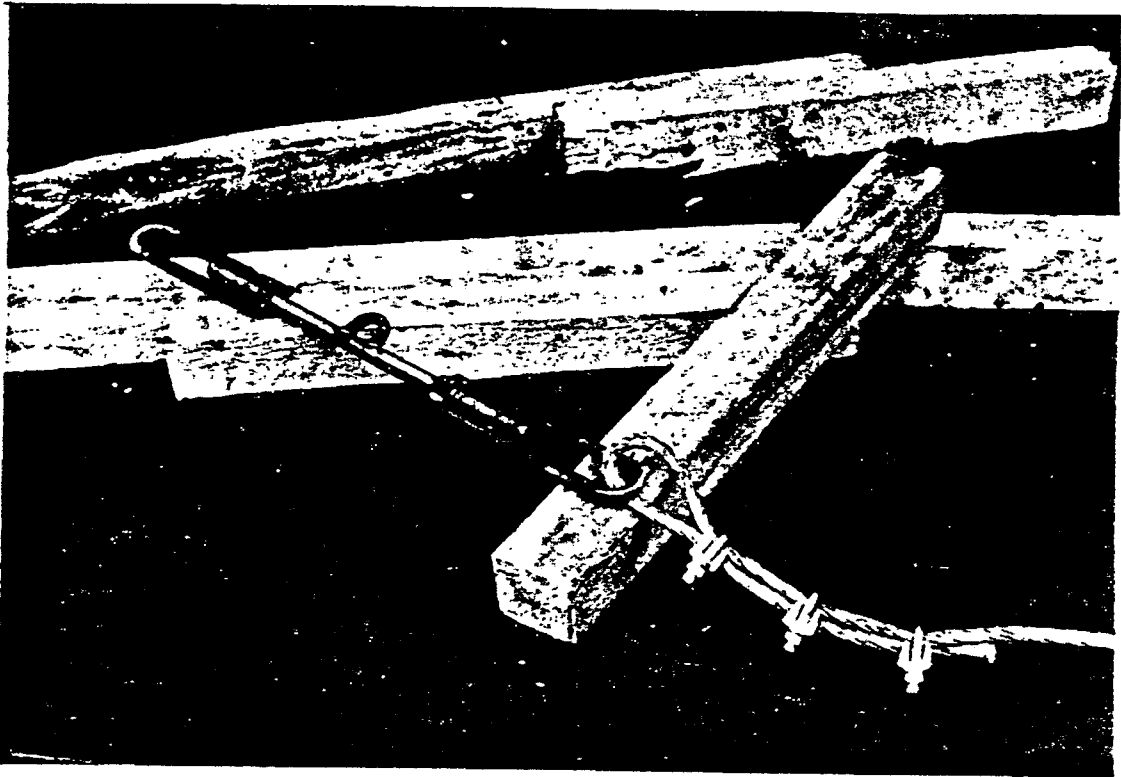

vii.

Three grips applied all in the wrong direction and the cut end not whipped or taped. This eye will slip suddenly at loads below 3 tonnes.

viii.

Three grips in the wrong direction, the second and last applied to wire which has opened up through lack of whipping. This eye will slip at loads below 2 tonnes.

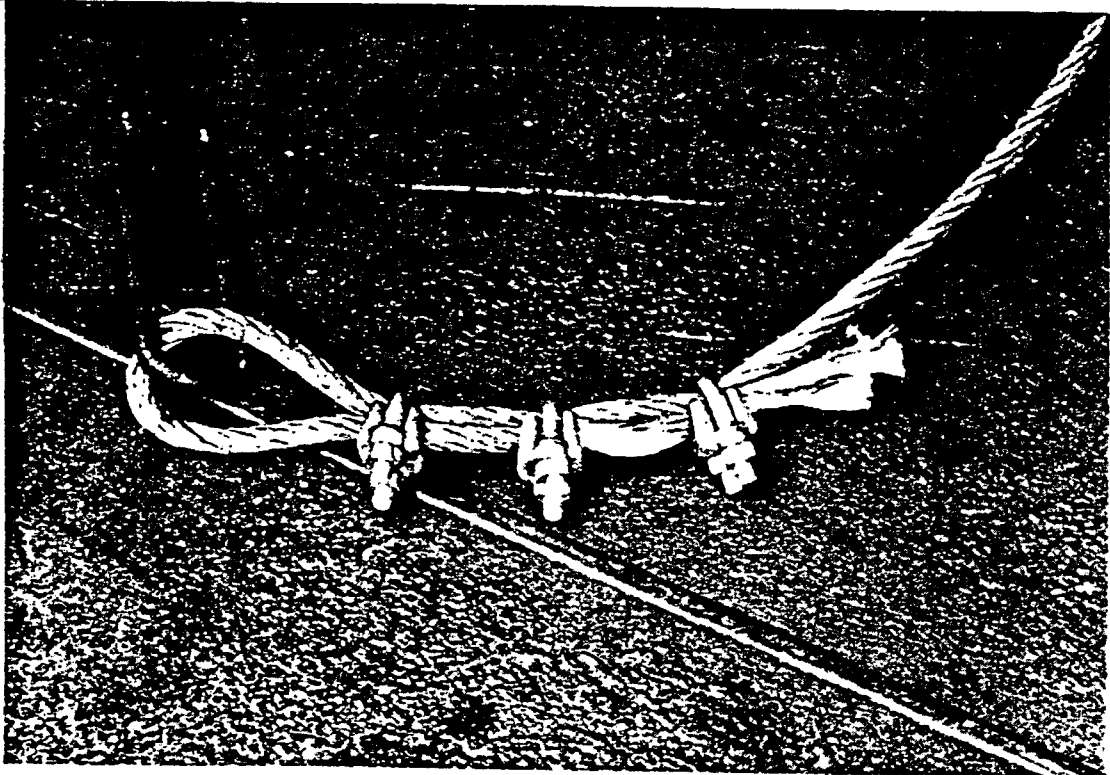

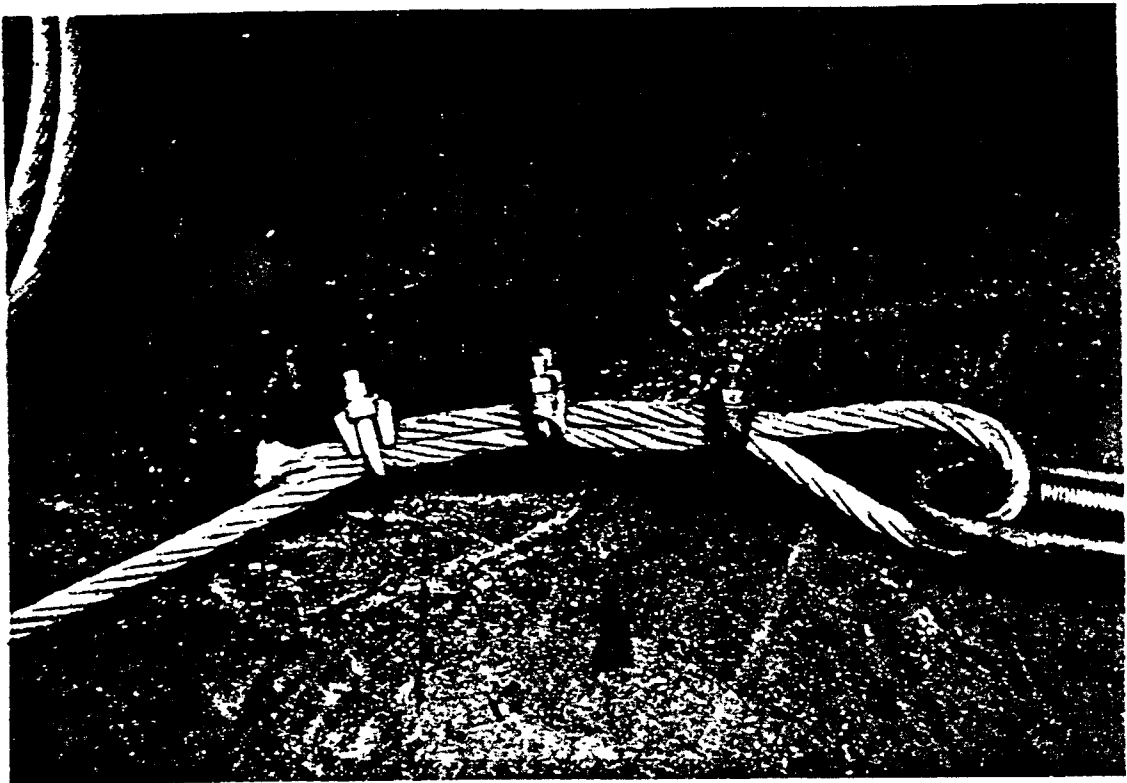

v.

Three grips all applied in the wrong direction, the end clip too near the cut end and the cut end not whipped or taped. This eye will hold to about 3 tonnes, but will slip suddenly as cut end unlays.

vi.

Three grips used in the wrong direction, the end grip pressing on wire which has opened up, and the cut end not whipped or taped. The eye shown here will slip suddenly at loads below 3 tonnes.

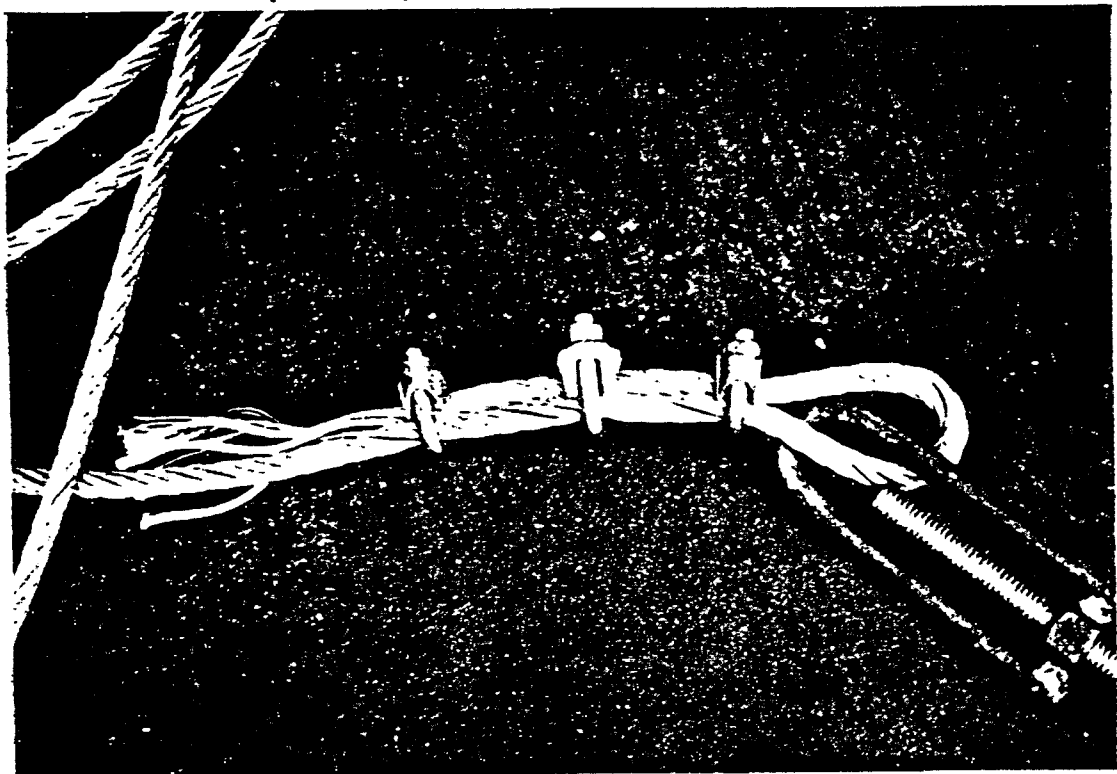

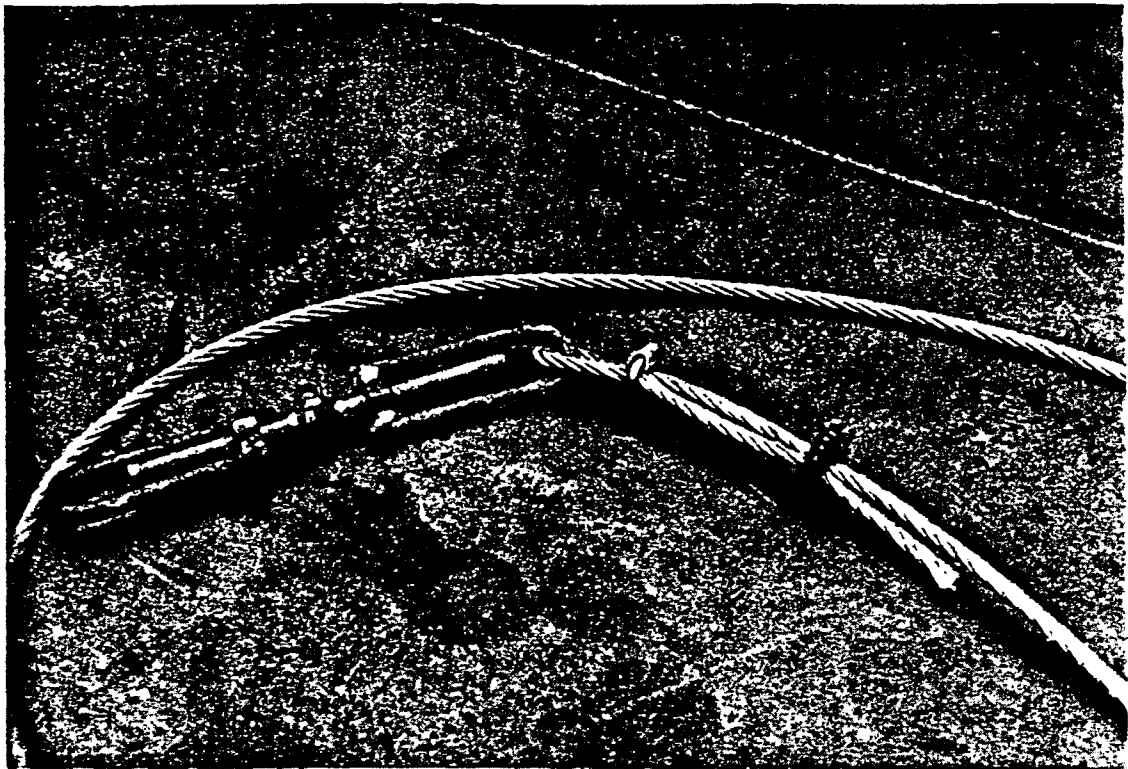

iii.

Two grips, only, applied in the correct direction but too far apart and the cut end not whipped. The eye will hold about 2 tonnes to start with, but will slip suddenly as the cut end unlays.

iv.

Three grips applied in the correct direction, too close together, and over dead wire which has opened up and is not whipped. This eye will slip suddenly at loads of between 1 and 2 tonnes.

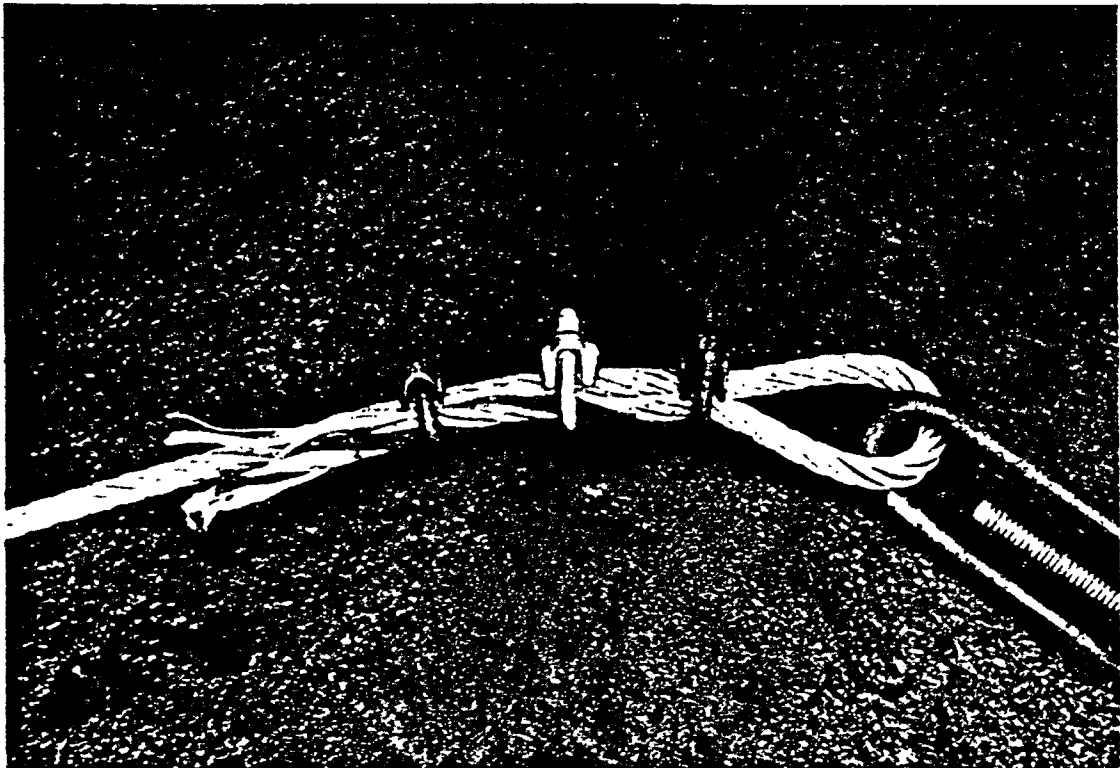

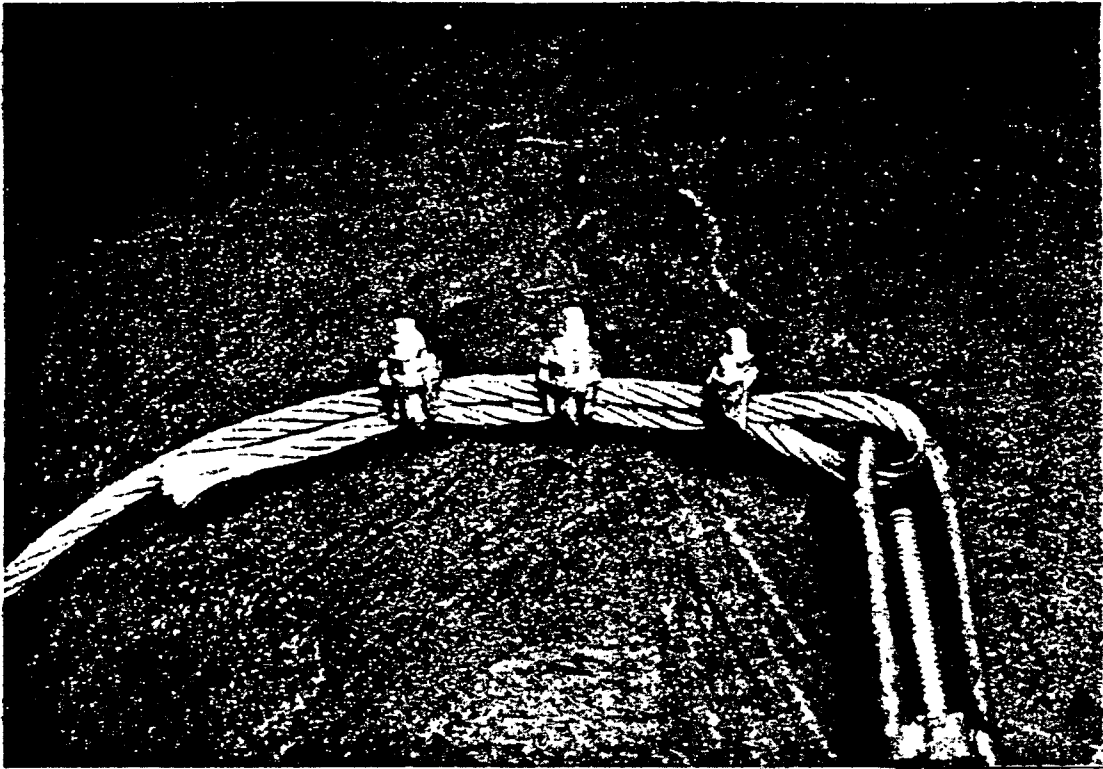

i.

Bulldog grips applied in the correct direction, but slightly too close together (they should be 4" apart for this size of wire), and the cut end has not been whipped or taped. Will hold well to start with, but will slip suddenly under low load as cut end unlays.

ii.

The worst of all worlds: 2 grips in opposite directions and the cut end opening up. This eye will slip at loads of 1 tonne or less.

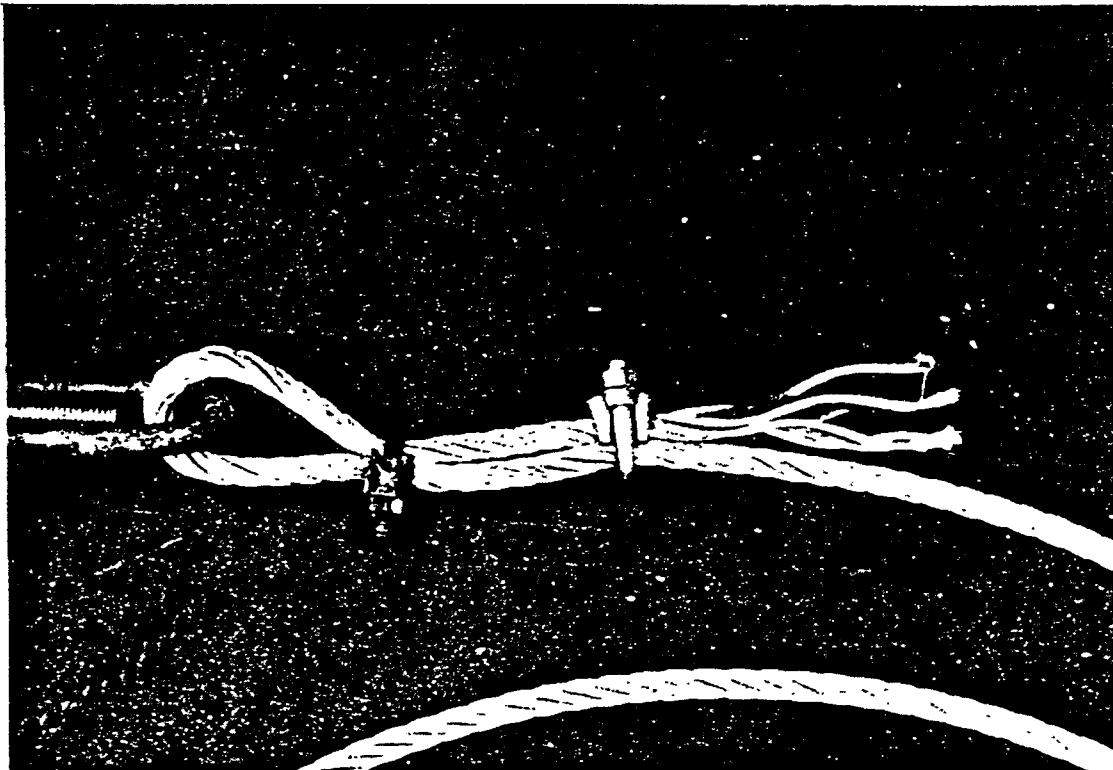

## BIBLIOGRAPHY .

- [11] ANDERSSON, PETER; KOCH, MICHAEL; SJOEBRIS, ANDERS.  
"Optimum Safety Factors for Securing of Cargoes  
on Board Ships".Kompendietry-Kaellared Goeteborg 1986.
  
- [12] ANDERSSON, PETER; ALLENSTROEM B., NIILEKSELAE, MARTTI.  
"Safe Stowage and Securing of Cargo on Board Ships".  
MariTerm AB Goeteborg 1982
  
- [13] ANDERSSON, PETER.  
"Securing of Road Trailers on Board Ro/Ro Ships".  
MariTerm AB Geborg 1983.
  
- [14] BHATTACHARYYA, RAMESWAR.  
"Dynamics of Marine Vehicles"  
John Wiley and Sons Interscience Publication.  
New York 1978.
  
- [15] BUXTON I.L., DAGGITT R.P.  
"Cargo Access Equipment for Merchant Ships".  
Mac Gregor Publications Ltd.  
London 1978.
  
- [16] FRAMPTON R.M. and UTTRIDGE P.A.  
"Meteorology for Seafarers".  
Brown, Son and Ferguson LTD.  
Glasgow 1978.
  
- [17] GOULD R.W.F.  
"The Estimation of Wind Load on Ship Superstructures".  
The Royal Institution of Naval Architects 1982.
  
- [18] HOOKE, NORMAN.  
"Modern Shipping Disasters ( 1963-1987)".  
Lloyd's of London Press LTD 1989.



- [9] IMMER, JOHN R.  
"Cargo Handling".  
Work Saving International. Washington 1984.
- [10] KAPS, HERMANN.  
"Cargo Securing Calculations". Bremen 1987.
- [11] KAPS, HERMANN; KASTNER, SIGISMUND.  
"Safe Stowage and Securing of Cargo, Cargo Units  
and Vehicles".  
Forschunghaben Ladungssicherheit Seeverker An.7E.  
Bremen November 1984.
- [12] KAPS, HERMANN; KASTNER, SIGISMUND.  
"The Phisical and Operational Background of  
Cargo Securing Aboard Ships".  
Annex to IMO-Paper BC 26/4/7.
- [13] KASTNER, SIGISMUND.  
"Operational Stability of Ships and  
Safe Transport of Cargo".  
Third International Conference on Stability of Ship  
and Ocean Vehicles ( Gdnask September 1986 ).
- [14] KASTNER, SIGISMUND.  
"Proposed Framework for the Calculations of Lashing  
Forces for Practical Use on Board Ships,  
and on Actions to be taken in Heavy Weather.  
Ship Hydromechanic Laboratory. Bremen July 1985.
- [15] KASTNER, SIGISMUND.  
"Ship Response to Ocean Waves".  
Laboratory for Ship Hydromechanics/Ocean Engineering.  
Bremen August 1988.

- [16] KASTNER, SIGISMUND.  
"Stability of Ships in Following Seas".  
Laboratory for Ship Hydromechanics/Ocean Engineering.  
Bremen August 1988.
- [17] CAPTAIN KNOTT, JOHN R.  
"Lashing and Securing of Deck Cargoes".  
The Nautical Institute. London 1985.
- [18] KOTSCH, J. WILLIAM.  
"Weather for Mariner".  
Naval Institute Press (3rd edition). Annapolis 1983.
- [19] LECHUGA, MANUEL PALAO.  
"Considerations for Modern Container, Trailer and  
General Cargo Securing Systems".  
Planmarine.
- [20] LEVIS, EDWARD V.  
"Principles of Naval Architecture" Second Revision.  
(Vol.3: Motions in Waves and Controllability).  
The Society of Naval Architects and Marine Engineers.  
Jersey City 1989.
- [21] CAPTAIN MACKIE G.V.  
"Avoiding the Heavy Weather Route".
- [22] MSC-CIRCULAR No.530.  
"Code of Safe Practice for Cargo Stowage and Securing".
- [23] CAPTAIN MOTTE R.  
"Weather Routeing of Ships"  
Maritime Press. London 1972.

- [24] **PACKARD, V. WILLIAM.**  
"Sea Trading: The Ships (Vol. 1), The Cargoes (Vol.2).  
Fairplay Publications. London 1984 and 1985.
- [25] **CAPTAIN TAYLOR L.G.**  
"Cargo Work:the Care, Handling and Carriage of  
Cargoes".  
Brown, Son and Ferguson Ltd (Eleventh Edition).  
Glasgow 1985.
- [26] **CAPTAIN THOMAS R.E.**  
"Thomas' Stowage: The Properties and Stowage of  
Cargoes".  
Brown, Son and Ferguson Ltd. Glasgow 1983.
- [27] **CARGO SYSTEMS INTERNATIONAL.**  
"Proceedings of the Safe Ship/ Safe Cargo Conference".  
Vol.2. Held in London 29-30 September 1987.  
Cargo Systems Publications Ltd. Surrey 1987.
- [28] **CARGO SYSTEMS INTERNATIONAL.**  
"Safe Cargo Conference".  
Vol.1 held in Helsingborg 16/17/April 1985.  
Cargo Systems Publication Ltd. Surrey 1985.
- [29] **GREAT BRITAIN METEOROLOGICAL OFFICE.**  
"Meteorology for Mariners".  
London H.M. Stationery Office 3rd. 1978.
- [30] **LLOYD'S REGISTER.**  
"CASUALTY RETURN: 1984, 1985, 1986, 1987, 1988".  
Lloyd's Register of Shipping London.

**[31] SWEDISH MARITIME INVESTIGATION COMMISSION.**

"Marine Accident Report: Fire on Cargo Deck  
in Ro/Ro Vessel Finneagle in October 1980".  
Released February 1982.

**[32] SWEDISH MARITIME INVESTIGATION COMMISSION.**

"Marine Accident Report concerning the Heeling  
and Capsizing of the Swedish-flagged Ro/Ro Ship  
Vinca Gorthon in the North Sea 1988". September 1989.

**[33] THE ROYAL INSTITUTE OF NAVAL ARCHITECTS.**

"International Symposium on Wave and Wind,  
Climat Worldwide".  
London 12 and 13 April 1984.