

World Maritime University

The Maritime Commons: Digital Repository of the World Maritime University

World Maritime University Dissertations

Dissertations

1989

Safe transport operations, handling and storage of dangerous cargoes in the ports of Pakistan

Rahmat Ali

World Maritime University

Follow this and additional works at: https://commons.wmu.se/all_dissertations

Recommended Citation

Ali, Rahmat, "Safe transport operations, handling and storage of dangerous cargoes in the ports of Pakistan" (1989). *World Maritime University Dissertations*. 1311.

https://commons.wmu.se/all_dissertations/1311

This Dissertation is brought to you courtesy of Maritime Commons. Open Access items may be downloaded for non-commercial, fair use academic purposes. No items may be hosted on another server or web site without express written permission from the World Maritime University. For more information, please contact library@wmu.se.

WORLD MARITIME UNIVERSITY
MALMÖ, SWEDEN

SAFE TRANSPORT OPERATIONS, HANDLING AND STORAGE OF
DANGEROUS AND HARMFUL CARGOES IN THE PORTS OF PAKISTAN

by

Rahmat Ali

Pakistan



A paper submitted to the Faculty of the World Maritime University
in partial satisfaction of the requirements for the award of a

MASTER OF SCIENCE DEGREE
in
MARITIME EDUCATION AND TRAINING (NAUTICAL).

The contents of this paper reflect my personal views and are not
necessarily endorsed by the UNIVERSITY.

Signature:

Date: 17 October, 1989

Supervised and assessed by:

Stephen J. Cross
Lecturer
World Maritime University

Co-assessed by:

Capt Karsten Brünings
Director Projects
Port and Transport Consulting GmbH
Visiting Professor World Maritime University

I dedicate this to the memory of late father,
Qazi Hifazat Ali who meant so much to me and whose
love always encouraged me to work hard in life.

CONTENTS

Title	Page No.
Acknowledgements	iv
Abstract	vi
Preface	vii
Definitions	xi
List of Abbreviations	xiii
Chapter 1 INTRODUCTION	
1.1 History	1
1.2 Role of United Nations	3
1.3 Chapter VII of SOLAS (1974) Convention	6
1.4 International Maritime Dangerous Goods (IMDG) code	10
1.5 Role of Competent Authority	17
1.6 Summary	17
Chapter 2 PAKISTAN A BRIEF OVERVIEW	
2.1 Introduction to Pakistan's economy	20
2.2 Trade	20
2.3 Ports and Facilities	21
2.4 Port Mohammad Bin Qusim	21
2.5 Karachi Port	22
2.6 Handling of Dangerous Goods in Port and adjacent areas (Exports)	23
2.7 Problems of Karachi Port	36
Chapter 3 LEGISLATION	
3.1 Purpose of Legislation	40

3.2	Current Legislation/Regulations	48
3.3	Summary	63
Chapter 4	EDUCATION AND TRAINING	
4.1	Introduction	65
4.2	Reasons for Education and Training	67
4.3	Situation in Ports	72
4.4	Type of Training	75
4.5	The Composition of Target Groups	79
4.6	Training Opportunities/Facilities	81
4.7	Training Implementation	82
4.8	Proposed Dangerous Goods Course	86
4.9	Training and Instructors	91
Chapter 5	CONCLUSIONS AND RECOMMENDATIONS	92 <i>92</i>
List of References		(4)
Annex I	Explosives	(7)
Annex II	Quantity Limits of Dangerous Goods in Port	(1)
Annex III	Dangerous Goods Warehouse	(1)
Annex IV	Recommended Minimum Segregation of Dangerous Goods in Port Areas	(1)
Annex V	Fire in T.P.X and Port Areas	(5)
Annex VI	Statement of official (Daily Dawn)	(1)
Annex VII	Gazette Notification S.R.O 43 (KE)84	(2)
Annex VIII	Fires (Newspaper Clippings. February, 89)	(1)
Annex IX	Map of Dangerous Goods Shed	(1)
Annex X	Map of Karachi Port showing Western Backwaters Complex	(1)

ACKNOWLEDGEMENTS

All praise and gratitude belong to the Almighty God for sustaining me during the period of my post-graduate studies at the World Maritime University.

I wish to express my deep gratitude and sincere thanks to:

- Rear Admiral Sajjad Akbar, Director General Ports and Shipping, Ministry of Communication and Commodore Shahid Afzal, Commandant Pakistan Marine Academy for my nomination at WMU;
- International Maritime Organization for awarding me the fellowship;
- Sasakawa Foundation of Japan for sponsoring me;
- Mr. R.J. Fazellani, The Traffic Manager of K.P.T. for providing me all assistance and useful information;
- Captain Hubert E.H.S. Wardelmann, Head, Cargoes Section, Maritime Safety Division (IMO) for giving me ideas and providing me useful material;
- Professor Gunther Zade, for providing initial guidance and help in all stages of my studies;
- my Assessor, Captain Stephen Cross for his guidance whilst directing the paper;

- my Co-Assessor Captain Karsten Brunings, Director Projects, Port and Transport Consulting, West Germany. for his guidance, critical and useful comments whilst assessing the paper;
- Frank L. Wiswall, Jr. Proctor and Advocate in Admiralty, Meadow Farm, Castine, Maine U.S.A. for advising me on various aspects of Maritime Law;
- members of the Library of WMU and specially Mr. Richard Poisson for his help in the location of most needed reference material;
- all those individuals, institutions and organizations in Pakistan, West Germany, Holland and United Kingdom who have provided me with the necessary information for the completion of this paper; and
- my fellow colleague and friend, L.O.F. Beriweriso of Nigeria for friendly advice and motivation.

In closing, I would like to thank my loving wife, Nuzhat, my children Asad, Saad, Nageen and Omar for providing me with encouragement and unfailing support.

ABSTRACT

This study deals with the subject of dangerous goods and safety in the ports of Pakistan and in particular, Port of Karachi. The purpose is not an attempt to highlight the short comings nor could it rectify short comings. This is purely an attempt at underscoring the risk factors inherent to industry under normal operating conditions and is suggesting, that by adaptation and implementation of International regulations And following practices of established systems and procedures of other developed countries, shall create a safer environment and prevent unwanted occurrences.

It is evident that in some instances a false sense of security, fortunately due to the lack of very serious incidents, has been created in certain areas of the industry. This feeling of complacency is harmful and needs to be changed. Prudent operations at all levels, though sometimes difficult, will create and continue to evolve a healthy and safe environment.

One of the most important tasks of Port Management is to implant a high degree of safety consciousness into its organization. Governing Bodies, Port Authorities, may invest vast sums on all types of high technology and expensive accident preventive appliances, yet in the absence of safety consciousness at all levels of the organization, this investment is merely wasted.

SAFE TRANSPORT OPERATIONS, HANDLING AND STORAGE OF

DANGEROUS AND HARMFUL CARGOES IN THE PORTS

OF PAKISTAN.

PREFACE:

With the technical progress, the advent of new substances and materials and the exigencies of modern transport systems have considerably increased the potential risks and hazards attached there to. Thus the carriage of dangerous substances has become a major concern for all those involved in sea transport because of safety and pollution.

To meet these challenges, new international regulations have come into force and shall continue to develop further. The maritime law has moved far beyond its traditional base and includes a number of important aspects of the law of the sea, environmental law and law on policy for dangerous and harmful cargoes.

In developing countries the education and training have not kept pace with these developments in the maritime industry as a whole and particularly in the field of dangerous substances.

These factors have caused or contributed to the following problems in the ports of developing countries including Pakistan:

- Enormous increase in quantity and varieties of dangerous substances passing through the ports;
- Outdated regulations and administrative procedures;
- Lack of awareness on the part of port policy makers and planners;
- Hesitation on the part of officials for framing new regulations in view of encountering enormous difficulties in the process;
- Unskilled labour due to lack of training;
- Lack of specialized facilities and equipment;
- Lack of training facilities and trained instructors; and
- Extension of ports which occasionally is not in line with the intended planning.

In the light of the above mentioned difficulties, the purpose of this paper is to make a comprehensive study of the existing situation in Pakistan and then to bring the concerned authorities, port personnel and port users to an awareness of safety requirements for the transportation, handling and storage of dangerous and harmful cargoes in the ports. Furthermore, Education and training is a prerequisite for developing better approaches and improvements in the over all existing conditions and to bring current practices in line with international

standards and thus ensuring the safety of people, property and the environment.

Dangerous substances are transported either in bulk, or in packaged and containerized form. Bulk cargoes are excluded from this study as it would go beyond the scope of this work due to volume restrictions. Hence, this study is restricted to dangerous and harmful cargoes in packaged and containerized form. The objectives of this paper are:

- .1. To create awareness about potential dangers associated with dangerous cargoes and safety requirements;
- .2. To improve the ~~the~~ existing practices in transportation, handling and storage of dangerous goods in ports compatible to international standards;
- .3. To emphasize the need of proper storage facilities;
- .4. To have an up-to-date maritime legislation on the handling and storage of dangerous goods;
- .5. To implement an appropriate legislative frame work within which storage and handling of dangerous goods in ports and other complementary activities of maritime transport can be handled or carried out;
- .6. To develop training programmes for seafarers, port personnel, and other users of the port for the transportation, handling and storage of dangerous goods; and
- .7. To achieve the safety of Port and her environments.

In the ~~the~~ light of the above, chapter one of this paper is a general introduction which gives a historical background of the transportation of dangerous goods, the role of United Nations and, other specialized agencies and especially of IMO in the transportation, handling and storage of dangerous goods.

Chapter two deals with the handling of dangerous goods in Pakistan, especially in Port of Karachi. It gives the general overview, the Port facilities and the present problems of handling, and storage of dangerous goods.

Chapter three concentrates on the legislation and the need for Pakistan to have an upto date legislation and regulations on the transportation, handling and storage of dangerous goods both on ships and shore as compatible practices are essential for a safe land and sea interface.

chapter four stresses on the need for specialized Training and Education programmes on dangerous goods for a generic group of trainees comprising of port personnel, seafarers and other users of port. This will result in better approaches by understanding each others problems and shall result in good cooperation between them.

chapter five contains recommendations and conclusions.

DEFINITIONS

For ease of reference and clarity, definitions in IMO Publications are included.

DANGEROUS GOODS

means any receptacle, portable tank, freight container or vehicle. The term includes an empty, receptacle, portable tank or tank vehicle which has previously been used for the carriage of a dangerous substance unless such receptacle or tank has been cleaned and dried, or, when the nature of the former contents permit with safety, has been securely used. 1?

DANGEROUS GOODS IN PACKAGED FORM

This covers inter alia small receptacles, or cylinders upto 1000 liters, bags, boxes, cans, drums upto 450 liters, unit loads, intermediate bulk containers, portable tanks, road and rail vehicles and other cargo transport units and shipborne barges.

BULK DANGEROUS SUBSTANCES

means any dangerous substance, carried without any intermediate form of containment, in a tank or cargo space which is a structural point of a ship or in a tank permanently fixed in or on a ship.

DANGEROUS SUBSTANCES

means any substance, whether packaged or in bulk intended for carriage or storage and having properties coming within the classes listed in the IMO "International Maritime Dangerous Goods" (IMDG) Code.

Furthermore, it means any substances shipped in bulk not coming within the IMDG Code classes but which is subject to the requirement of the IMO "Code for the Construction and Equipment of Ships Carrying Dangerous Chemicals in Bulk", or Appendix B of the IMO "Code of Safe Practice for Solid Bulk Cargoes" in so far as such a substance may constitute a hazard to those in the Port Area or the Port Environment. It must be noted that there are certain substances which do not constitute a hazard when stored ashore but which may create problems affecting safety subsequent to their loading into a ship's hold. In this connection the necessity of complying with the provisions of the IMO "Code of Safe Practice for Solid Bulk Cargoes" is stressed.

Risk

means the rate of exposure to undesirable situations expresses the probability of occurrence of such situations combined with the detrimental effect of them on lives and/or properties.

LIST OF ABBREVIATIONS

AFFF	Aquas Film Forming Foam
BC Code	Code of Safe practice for Solid Bulk Cargoes
BCH Code	Code for the construction and Equipment of Ships carrying Dangerous Chemicals in Bulk
CSC	International Convention for Safe Containers
D.G. Shed	Dangerous Goods Shed
ECE	Economic Commission of Europe
ECOSOC	Economic and Social Council of the General Assembly of the United Nations
EmS	Emergency Schedules: The Emergency Procedures for Ships Carrying Dangerous Goods
FCL	Full Container Load
IAEA	International Agency for Atomic Energy
IBC	International Code for the Construction and Equipment of Ships Carrying Dangerous Chemical in Bulk.
IBCs	Intermediate Bulk Containers
ICAO	International Civil Aviation Organization

ILO	International Labour Organization
IMCO	International Maritime Consultative Organization
IMDG Code	International Maritime Dangerous Goods Code
IMO	International Maritime Organization
K.P.T.	Karachi Port Trust
LCL	Less Container Load
MARPOL	International Convention for the Prevention of Pollution from Ships, 1973 as modified by the Protocol of 1978 relating thereto
MEPC	Marine Environment Protection Committee (of IMO)
MFAG	IMO/WHO/ILO Medical First-Aid Guide for use in Accidents Involving Dangerous Goods
M.I. Yard	Mansfield Yard
MSC	Maritime Safety Committee (of IMO)
NMB	Napier Moll Boat (Wharf)
NOS	Not Otherwise (Schedule)
RID	International Regulations for the Transport of Dangerous Goods by Rail

SOLAS International Convention on the Safety of Life
 at Sea

STCW International Convention on Standards of
 Training, Certification and Watchkeeping for
 Seafarers, 1978

T.P.X. Thole Produce Yard (area)

UNCTAD United Nations Conference on Trade and
 Development

WHO World Health Organization

WMU World Maritime University

CHAPTER 1

INTRODUCTION

1.1. HISTORY

Transportation of dangerous goods by sea is an age old phenomenon. In the sailing era, the ships were small and usually one type of dangerous cargo was carried. It was very seldom that two cargoes of such kind were carried together. So the dangers due to cargo alone were negligible in comparison to the perils of sea.

With the development of technology, the trade patterns have changed. The development of new chemicals and their use are on the increase, the ships have grown in size and specialized in trade.

Now a days, more than 50% of cargoes transported are classified as dangerous. They could be either in bulk or packaged form. It is estimated that about 10-15 % of the above cargo is carried in break bulk form either in general cargo, multipurpose or container ships.

The rapid industrialization in the last three decades has caused the excessive use of chemicals which involved their transportation and increased the attached potential hazards of safety and pollution. Now these dangers made it inevitable to have some kind of legislation to regulate the flow of cargo in an orderly manner.

Dangerous goods were first mentioned in the British Merchant Act 1894, Article 301 "Dangerous goods and carriage of cattle". The article stipulated that an

emigrant ship shall not proceed to sea if she carries an explosive within the meaning of Explosive Act 1875 or any vitriol, lucifer, matches, guano or green hides or.... any article....which by reasons of nature, quantity or mode of storage.... is likely to endanger the health or lives of the passenger or the safety of ship or....".It is interesting to mention that the above Act of 1894 is still in force in Pakistan.

1.1.1. EVOLUTION OF SOLAS

The first international convention on the safety of life at sea SOLAS 1914, considered, and was influenced by, the British Merchant shipping Act 1894. The convention prohibited the carriage of goods which by reason of their nature, quantity or mode of storage, were likely to endanger the lives of the passenger or the safety of ship. It was obligatory on each contracting party to decide from time to time which goods should be considered dangerous and precautions to be indicated for safe packing and stowage. Although this convention never came into force, the principle of relying on national administration to decide on the definition and treatment of dangerous goods was established and resulted in diversified regulations and practices in different countries.

SOLAS 1929 convention was more or less on the same lines of which Article 24 about dangerous goods was mentioned together with life saving appliances. The SOLAS 1929 came into force in 1933. In principle the above convention forbade the carriage of dangerous goods which by their nature, quantity and mode of stowage endangered the lives of passengers and safety of ship. So the dangerous criteria depended on quantity, nature and mode of

transport. It was left to contracting governments to mutually decide among themselves as to which cargoes should be classified as dangerous. This regulation was very broad and depended on parties mutual interpretation /agreement, hence different rules and practices came into existence. AS the trade grew, it was recognized that the regulations are inadequate to meet the requirements.

1.1.2. NEW DEVELOPMENT IN SOLAS

In SOLAS 1948 convention a new chapter "Carriage of Grain and Dangerous Goods" was incorporated. It stated that the dangerous criteria should be established by virtue of their properties and characteristics and not by nature, quantity and mode of stowage. Additionally, a labelling system should be developed with distinctive colours and symbols to indicate clearly the dangers involved. They adopted recommendation 22, recognizing the need for international uniformity in safety precautions. The convention also agreed that further studies shall be undertaken for the development of new regulations. These recommendations were not acted upon immediately because IMO (then IMCO) convention called in 1948 did not come into force until 1958.

1.2. ROLE OF UNITED NATIONS

Meanwhile, in 1953 the United Nations (UN) committee of experts on the transport of dangerous goods was set up under the (UN) Economic and Social council (ECOSOC). The committee considered the international aspect of the carriage of dangerous goods by all modes of transport and submitted its report in 1956. (Anonymous, May 1988)

The recommendations are based mainly on the existing national regulations and on the studies undertaken by various agencies dealing with the transport of dangerous goods by a specific mode of transport. The report described a general framework, broad and flexible enough into which national and international regulations could be incorporated and further developed. (Wardelmann, 1988 a)

The recommendations covered principles of classification and definitions of class, listing of principle dangerous goods, general packing requirements, testing procedures, marking, placarding and documentation.

The aim is to give a basic scheme of provisions so as to allow national and international regulations to grow within a framework and thus attain a uniformity in regulations for all modes of transport, ultimately leading for unhampered multimodal transport operation. The rules framed are to eliminate or reduce to a minimum the risks of accidents to persons, property and other means of transport. The underlying principles for framing regulations is not to impede the movement of dangerous goods, except those cargoes, which are too dangerous to be accepted for transport. Hence, a balance was drawn between safety and facilitation of transport.

The UN classification is based on scientifically achieved analysis and the classes 1 to 9 are not in the order of the degree or magnitude of hazards of the dangerous good, rather the classification is one by the type of risk involved in order to meet technical conditions of transport. Today, this classification is incorporated in Regulation 2 of chapter VII of SOLAS 1974.

However, these UN recommendations are not suitable for direct implementation as they lack the details required for modal application. This detail is expected to be provided by International Maritime Organization, IMO being the recognized authority for adopting details for the maritime mode. (Henry, 1985)

1.2.1. OTHER INTERNATIONAL ORGANIZATIONS

There are few other international agencies which are dealing with dangerous substances and among them are:

- Economic Commission of Europe (ECE);
- The International Agency for Atomic Energy (IAEA);
- The International Regulations for the Transport of Dangerous Goods by Rail (RID);
- United Nations Commission on Trade and Development (UNCTAD);
- International Labour Organization (ILO);
- World Health organization (WHO);
- International Civil Aviation Organization (ICAO);
- International Airlines Transport Association (IATA);
- and
- The Organization of the Socialist Countries.

Finally, it can be concluded that the carriage of dangerous substances has been dealt with in various international forums and is regulated by a large number of international instruments.

1.2.2. INTERNATIONAL MARITIME ORGANIZATION (IMO)

IMO (then IMCO), a specialized agency of UN system,

It is a highly technical body and effects international legislation for maritime safety, through conventions, protocols, resolutions, standards, guidelines, codes, and recommendations. She held her first assembly in 1959. Her main objective was to revise 1948 SOLAS. The conference took place in 1960 and adopted the SOLAS 1960 convention which came into force on 26th May, 1965. The chapter V11 of that conference contains only "Carriage of Dangerous Goods" and deals with both dangerous cargoes in packed form as well as with bulk cargoes. Additionally, chapter V11 was supplemented by resolution 56 of the conference recommending the governments to adopt a uniform international code for the carriage of dangerous goods by sea.

Another conference held in 1974, revised the 1960 SOLAS and chapter V11 of SOLAS 1960 was replaced by chapter V11 of SOLAS 1974, which entered into force on 25th May, 1980. Further amendments to SOLAS 1974 were adopted in November 1981 and June 1983, which came into force in September 1984 and July 1986 respectively.

In pursuant to the decision of the assembly of IMO at its fifteenth session and the Maritime Safety Committee at its fifty-fifth session, a diplomatic conference was convened and adopted on 11th Nov 1988, "Protocol of 1988 Relating to International Convention for the Safety of Life at Sea, 1974".(HSCC/CONF/11). This will replace SOLAS Protocol 1978, if and when it comes into force.

1.3. CHAPTER VII OF SOLAS (1974) CONVENTION

Present chapter V11 of SOLAS 1974 deals with carriage of dangerous goods: Part A-Carriage of dangerous goods in

packaged form and in solid bulk form; Part B-Construction and equipment of ships carrying dangerous liquid chemicals in bulk; and part C-Construction and equipment of ships carrying liquefied gases in bulk.

Regulation 1.3 of chapter VII prohibits the carriage of dangerous goods except when carried in accordance with the provisions of part A of chapter VII, which are amplified by the International Maritime Dangerous Goods (IMDG) Code.

Regulation 2 of part A of chapter VII divides the dangerous goods into the following classes.

- Class 1 - Explosives.
- Class 2 - Gases: Compressed, liquified or dissolved under pressure.
- Class 3 - Flammable liquids.
- Class 4 - Flammable solids.
- Class 4.2 - Substances liable to spontaneous combustion.
- Class 4.3 - Substances which, in contact with water, emit flammable gases.
- Class 5.1 - Oxidizing substances.
- Class 5.2 - Organic peroxides.
- Class 6.1 - Poisonous (toxic) substances.
- Class 6.2 - Infectious substances.
- Class 7 - Radio active material.
- Class 8 - Corrosives.
- Class 9 - Miscellaneous dangerous substances, that is any other substance which experience has shown, or may show, to be of such dangerous character that the provisions of this part shall apply.

The other regulations of part A, 3-7 of chapter V11 deal with packing, marking, labelling and, placarding, documents, stowage requirements and explosives in passenger ships. These regulations are further supplemented by Regulation 54 of chapter 11-2 of the SOLAS 1974 convention which specifies the special requirements for a ship intended to carry dangerous goods, the keel of which is laid or which was at a similar stage of construction on or after 1st July, 1986.

In summary, Part-A of chapter V11 of SOLAS 74 with all up to date amendments provides the necessary legal basis for the international regulations for the transportation of dangerous goods at sea.

1.3.1. INTERNATIONAL CONVENTIONS OF IMO OTHER THAN SOLAS RELATED TO DANGEROUS GOODS

Another major convention of IMO is known as International Convention for the Prevention of Pollution from ships, 1973 as modified by the protocol of 1978 relating thereto (MARPOL 73/78), deals with various aspect of marine pollution.

Annex III to the MARPOL convention contains the mandatory provisions concerning the prevention of pollution by harmful substances carried at sea in packaged form. Regulation 1 (1.3) prohibits the carriage of harmful substances in ships except when carried in accordance with the provisions of Annex III. However, this Annex III will not come into force unless ratified by governments representing 50 % of world's merchant tonnage. Currently, the number of acceptances of MARPOL Annex III stands at 37 states with a total of 48.23 percent, but it is not clear

when the final 1.7 percent will be achieved. It is therefore uncertain when the legal requirements of the Annex will enter into force. (Anonymous, September 1989)

Now a new way is envisaged to implement the provisions of Annex III. The marine pollutants have been included in the IMDG Code. So, it is the IMDG Code which will be the vehicle for implementing the requirements of MARPOL Annex III. Taking into consideration the recommendation of the IMO Marine Environment Protection Committee at its twenty seventh session (13 to 17 March, 1989) to implement the marine pollution provisions with Amendment 25-89 to the IMDG Code, even if MARPOL 73/78 Annex III had not entered by that date, the Maritime Safety Committee unanimously agreed that Amendment 25-89 to the Code, which has been prepared with all the necessary provisions to implement the regulations embodied in Annex III, the text of which has been revised to incorporate recent changes together with other safety related changes should be implemented not later than 1st January, 1991.

Annex III comprises seven regulations and an appendix and the revised text will be included in the General Introduction to the IMDG Code. It contains requirements regarding packing, marking and labelling, documentation, stowage, quantity limitations and exceptions, but it does not list the substances to which it applies. Instead, regulation 1, which deals with application, states that they are those substances which are identified as marine pollutants in the IMDG Code. This means, if the substance is not listed by name in the IMDG Code, it is not a marine pollutant as far as Annex III is concerned.

Regulation 2 is concerned with packing and simply states that it should be adequate to minimize the hazard to the marine environment. Tests are currently being conducted to determine the durability of different types of packagings when immersed in seawater. The results may eventually lead to more detail specification of what is meant by "adequate".

Regulation 3 deals with marking and labelling and requires that packages are marked with correct technical name and labelled to indicate that the substance is a marine pollutant. The method of marking shall be such that the information will still be identified on those packagings which are capable of surviving three months immersion in the sea. This requirement, which is contained in Regulation 3(2) of Annex III, is identical to Regulation 4(3) on packaged dangerous goods of the revised Chapter VII of the SOLAS 1974 convention which entered into force on 1st July, 1986. Provision is made for packages containing small quantities of harmful substances to be exempted from these marking requirements.

Regulation 4,5,6 deals with documentation including a stowage plan of pollutants, proper stowage and "Quantity Limitations" respectively.

Regulations 7 provides for exceptions where it is necessary for the safety of the ship or its crew to allow the jettisoning of harmful substances or for washing spillages overboard.

1.4. INTERNATIONAL MARITIME DANGEROUS GOODS (IMDG) CODE

The IMDG code was introduced in 1965 by IMO assembly

resolution A.81(IV). This came as a consequence of SOLAS 1960 recommendation that governments should adopt a uniform international code for the carriage of dangerous goods. This task was achieved by its maritime safety committee through years of dedicated hard work.

The IMDG Code is recommended to Governments for adaptation or for use as the basis for national regulations in pursuance of their obligations under regulation VII/ 1.4 of the SOLAS 1974 Convention, as amended. Observance of the Code harmonizes the practices and procedures followed in the carriage of dangerous goods by sea and ensures compliance with the mandatory provisions of the SOLAS 1974 Convention, as amended.

So far, 45 countries including Pakistan whose combined merchant fleets totals more than 86 % of world's gross tonnage have informed IMO that they are applying the Code. The legal system of a country determines in detail whether IMDG Code becomes mandatory or is applied as a recommendation. Appliance of the Code as a recommendation does not detract in any way from the obligations imposed by SOLAS 1974 Convention, as amended, but merely provides a greater flexibility. (Anonymous, August 1989)

The present 1988 consolidated edition which includes all amendments upto 24-86 is in five volumes and basically designed to give guidance to comply with the general requirements of SOLAS 1974 Convention. It explains in detail the requirements applicable to each individual substances, material or article and has undergone many changes, both in layout and content, in order to keep pace with the expansion and progress of industry. The IMO Maritime Safety Committee is authorized by the assembly to

adopt amendments to the Code, thus enabling the IMO to respond promptly to transportation developments.

A completely new edition of the IMDG Code will be published by the IMO in January 1990. The new consolidated four-Volume 1990 edition incorporates the extensive revisions made by Amendment 25-89 adopted by the Maritime Safety Committee at its fifty-seventh session in April, 1989. The wide ranging and extensive changes to the code prompted by the inclusion of Amendment No 25 have provided the opportunity to implement a substantial reorganisation of the Code. For practical reasons, the General Index and Numerical Index of the IMDG Code have been incorporated with the General introduction and Annex 1 in Volume 1. The supplementary publications to the Code, i.e. Emergency Procedures (EMS), Medical First Aid Guide (MFAG), Solid Chemicals in Bulk (BC Code), Reporting Procedures, Packing cargo transport units have, for ease of reference, been consolidated in the supplement.



1.4.1. LEGAL ASPECTS OF THE IMDG CODE

SOLAS 1974 Convention, as amended, is a part of international legislation which is available for adaptation in national legislation for implementation. However, SOLAS 1974 Convention itself does not contain guidelines for implementation. The IMDG Code referred in the foot notes to regulations 1(4) and 4(4) in Part of Chapter VII of SOLAS 1974 Convention is an implementation instrument for compliance with requirements of Part A of Chapter VII. It could be said that these foot notes do not have the same legal force equal to that of a convention but these foot notes provide guidance for implementation of a part of SOLAS 1974 Convention.



1.4.2. CLASSIFICATION

The IMDG Code Classification is based on UN Classification system. While regulation 2 of chapter VII of SOLAS 1974 Convention, as amended, only gives a classification parameter, the IMDG code contains more details of those classes and provides direction to practical application on ships and in port areas. The IMDG code classification and definition of each class are contained in the general introduction of the code.

The definition of the classes given in the SOLAS convention or IMDG code are not precisely to the scientific sense of the words but rather aims to define the dangerous or hazardous nature of the cargoes and their placement into a class is according to their properties and characteristics. This means that the placement of a substance in a class is not by the degree of danger but by the type of danger only.

For the purpose of carriage of dangerous goods by sea, the classification has been made mandatory by Part-A of Chapter VII of SOLAS 1974 Convention, as amended, which deals with the carriage of dangerous goods in packaged form or in solid form in bulk and came into force on 1st July, 1986. (Wardelmann, 1989 b)

1.4.3. IMPROVEMENTS/CHANGES IN THE IMDG CODE

The 25th amendment to the code is one of the most important ever adopted because for the first time it extends its application to marine pollution. These provisions, together with the safety related changes, have

resulted in the largest amendment ever made to the code-
so large that a new IMDG Code 1990 version is produced.

The main features include:

- Provisions for marine pollutants (implementation of MARPOL Annex III);
- Intermediate Bulk Containers;
- Revision of all classes; and
- Entry into force of Annex I which refers to mandatory testing of packages (end of Grandfather Clause).

.1. Existing section 23 was introduced in the present IMDG Code by Amendment No 23- 86 which came into force on 6th April, 1987. It was meant solely for reporting purpose of packaged marine pollutants. The appendix to the current IMDG Code Section 23 lists about 170 such substances which must be identified in the transport documents as marine pollutants. All this will be replaced in an expanded Section 23 of the new IMDG Code (1990). It will not actually contain a list of marine pollutants as it is at present because it is thought that this duplicates the identification in the Code's index. The total number of entries has been greatly expanded (to over 400) but this is partly due to the identification of new substances as marine pollutants. Many of the additions stem from the fact that all "not otherwise specified" (NOS) schedules have been identified as potential marine pollutants. Obviously, not all cargo shipped under the provisions of an NOS schedule will have to be declared as a marine pollutant because many such cargoes do not contain IMDG listed substances. Nevertheless, every NOS schedule and its corresponding entry in the Code's index has been identified so that products which do qualify as marine pollutants are subject to the appropriate provisions.

Most marine pollutants are already entered as dangerous goods in the hazard class 2 to 8, but those that do not possess any such other hazard will be covered by one of the new entries in class 9 (miscellaneous dangerous goods).

These Are:

- environmentally, hazardous substances, solid, NOS, UN No 3077; and
- environmentally hazardous substances, liquid, NOS, UN No 3082.

Both these schedules will have appendices listing those substances which have been identified.

.2. Section 26 will be about Intermediate Bulk containers. It will contain:

- a preamble for a new section 26 to the code;
- general requirements applicable to all type of IBCs;
- specific requirements for metallic prismatic and flexible IBCs along with criteria for substances unsuitable for transport in these type of IBCs; and
- a list of substances suitable for transport in flexible IBCs.

Criteria establishing the nature of those substances unsuitable for transport in rigid plastics, composite, fibreboard and wooden IBCs is also identified.

.3. The packaging requirements of Annex 1 to the IMDG Code, i.e. which effectively reflects those of the UN system, become mandatory with the implementation of Amendment No 25 on 1st January, 1991. The implementation of Annex III of MARPOL on the same date will not impose

any additional packing standards on marine pollutants over and above of those required by compliance with the UN system.

In hazard class 2 to 8 packagings in the IMDG Code are based upon safety considerations, and so marine pollutants in these classes may require containment of Packing Group I, II, III standard. Similarly, carriage in portable tanks and intermediate bulk containers (IBCs) will depend upon safety factors rather than pollution potential. In class 9, however, the two schedules for environmentally hazardous substances will specify Packing Group III, and any effectively closed package complying with IMDG Annex I will be allowed. For all products carried under these two schedules, IMO Type 2 portable tanks and suitable IBCs will be allowed.

.4. Although the IMDG Code requires many dangerous substances to be placed on deck because of their hazard potential, marine pollutants should preferably be stowed under deck when ever practicable. In the final analysis safety aspects shall always be given precedence.

1.4.4. APPLICATION OF IMDG CODE

Though the IMDG code is designed primarily for mariners, its provisions have direct bearing on industries, warehouses, handlers and transporters. Complementary services such as rail, road, inland craft and harbour services are guided for classification, identification and labelling. Port authorities make use of the code for segregation in loading, discharging and storage areas.

1.5. ROLE OF COMPETENT AUTHORITY

The competent authority is usually nominated by the Maritime Administration. There are always some problems in practice for shipments of goods. Such problems in practice are referred to competent authority for clarification and decision. Occasionally, as in IMDG Code reference is made for competent authority approval, such interpretations and approvals have to be made by the nominated competent authority. It is this person/department who has to be contacted for anything concerning dangerous goods.

There had been problems in practice for acceptance of an approval unilaterally issued by originating competent authority. Now, it has been agreed and incorporated in section 22 of the general introduction to the IMDG code which spells out the terms with reference to competent authority approval. It stipulates that:

- An approval permit issued by a competent authority or a body authorized by a competent authority should be recognised by other countries;
- Such approvals and permits to comply with provisions of SOLAS 74 convention, as amended, MARPOL (73/78) Convention, as amended, and standards of IMDG code; and
- Addresses in individual countries to be provided to which inquiries regarding competent authority approval can be referred and shall have to be kept up to date.

1.6. SUMMARY

The production, movement and use of dangerous goods has increased rapidly in the last three decades.

Goods are considered dangerous because of their physical nature. But the extent of risks in the carriage of dangerous goods depends also on the packing of goods, means of transport, mode of stowage and segregation.

Since carriage of dangerous goods at sea is international, therefore uniform international regulations are required. The UN Recommendations for the transport of dangerous goods are in general form and have world-wide relevance for all modes of transport. These are international recommendations on which national and other international modal regulations are being based. The aim is to achieve unhampered multimodal transport operation. In an actual transport operation the applicable modal regulations need to be followed.

The IMO is the recognized authority for providing modal regulations for the maritime mode. It effects international regulations through international conventions, protocols, resolutions, standards, guidelines, codes and recommendations.

The Part-A of chapter VII of SOLAS (1974) Convention, as amended, provides the necessary legal basis for international regulations of dangerous goods at sea. The IMDG Code is based on UN Recommendations and is an implementation instrument to effect compliance with Part-A of Chapter VII of SOLAS (1974) Convention. The adoption of Amendment 25-89 has caused a whole revision of IMDG Code and resulted in the form of a new IMDG 1990 Code. It has extended its application to marine pollutants, enforcement of Annex I (mandatory packaging requirements), IBCs. The supplementary publications to the code, i.e. EMS, MFAG, BC Code, Reporting Procedures, Packing cargo transport

units have for ease of reference, been consolidated in the code.

The competent authority is the regulatory authority for safe transportation of dangerous goods at sea and provides guidance, clarification where references are made for competent authority approval.

It is obligatory on the part of an administration as a consequence after its ratification of SOLAS convention, the adaptation and implementation of the IMDG code, and with reference to competent authorities to set up a standing advisory committee of experts on the national level. This committee would advise the governing authorities in an administration to resolve the problems which may arise in operational practice. Since the Administration could not have all the expertise needed on the staff, such a group fills the gap. In this way Maritime Administration can effectively fulfill her legal obligations.

CHAPTER 2

PAKISTAN A BRIEF OVERVIEW

2.1. INTRODUCTION TO PAKISTAN'S ECONOMY

Pakistan is basically an agriculture country. In the export sector the main items are, cotton, cotton yarn, rice, fertilizer, molasses, petroleum product/ alcohol and neptha.

Though the industrial sector is constantly improving, still further efforts have been made to improve the economy by expanding the industrial base and boost the manufacturing output.

Chemicals are one of the most essential raw materials of industries. There is no sizeable chemical industry which exists in Pakistan to cater the domestic demand. Only about 10 % of the demand is met locally. Therefore all the major industries depend on the imported chemicals. Some of these chemicals are extremely hazardous and of dangerous nature. Besides these chemicals, there are other dangerous cargoes imported and exported through the ports of Pakistan. Bulk cargoes are excluded from this thesis as it would go beyond the scope of this work due to volume restrictions. Hence, this study is restricted to dangerous and harmful cargoes in packaged and containerized form only.

2.2. TRADE

Trade is sine-qua-non for economy and development of the country. To achieve this, reliable and efficient transport

systems with efficient ports and associated facilities are of paramount importance. The port is the strategic point and the most important factor for the success of maritime transport systems. The reason being:

- .1. It is an interface between sea and hinterland because here the sea transport is connected to land transport (rail, road, inland water transport system);
- .2. It is the handling point of transshipment of cargoes; and
- .3. It acts as a temporary warehouse for intermediate storage of cargoes.

Hence, summing up the above points it can be said that a port is the vital link of an inter-modal transport system.

2.3. PORTS and FACILITIES

To facilitate it's trade, there are two major ports in Pakistan, i.e. port of Karachi and port Mohammad Bin Qasim. The port of Karachi prior to 1973 was the only main port of Pakistan catering the entire need of the country and in addition, for transit cargo to Afghanistan. Although, in addition there are some very small ports, but those are basically fishing harbours. Hence, an additional major port (Port Mohammad Bin Qasim) was planned and developed which became operational in September, 1980.

2.4. PORT MOHAMMAD BIN QASIM

It is located about 50 kilometers south west of Karachi. It evolved as a result of a master plan with multi purpose facilities. It is an industrial port. Besides iron ore and coal berth there are seven multi purpose berths. This port

is not handling any dangerous cargo of any significance and as such this port shall not be dealt in any detail except in general context with reference to ports. Besides being a new port, it can adopt to any new trend of cargo flow including dangerous substances. However, it would be wise on the part of port planners to keep their options open and keep in mind for future plans about the handling and storage of dangerous and hazardous cargoes in port areas.

2.5. KARACHI PORT

It is a natural port and started functioning in about 1838. Over the period it has grown gradually to its present position. It has four tanker berths for the imports of crude oil, fuel oil, refined oil, petroleum products, edible oils, chemicals and export of molasses and neptha. These tanker berths are located in the lower part of the harbour and quite separate from dry cargo berths. There are 28 dry cargo berths situated in the upper part of the harbour out of which 17 berths are located on the east wharf and 11 berths on west wharf. All general cargo in break bulk, containers, ro-ro vessels, etc, are handled there. In addition there are few mooring and a vessel has to discharge her commercial cargo of explosives (class 1) before moving in to the upper part of the harbour.

The amount of cargo tonnage handled in Karachi port has been increasing over the years and as per statistics chart of Traffic department of Karachi Port Trust is as follows:

1976 - 77	9590762	M.Tons
1981 - 82	15137376	M.Tons

1987 - 88 17718035 M.Tons

Consequently due to the above trend of increased handling of cargo tonnage the port has experienced a big growth of dangerous and hazardous cargo tonnage as well, as can best be seen from the extracts of the above mentioned chart.

	1976-77	1981-82	1987-88
Liquid bulk	4270439	7127092	7957760 M.Tons
(petroleum products)			
* cotton	23180	186607	397286 M.Tons
* Oil cake	49971	-	10762 M.Tons
* Chemicals(imports)	11042	15410	46433 M.Tons
Totals	4354632	7329009	8412241 M.Tons

2.6. HANDLING OF DANGEROUS GOODS IN PORT AND ADJACENT AREAS (EXPORTS)

Pakistan's main export is cotton and only a negligible quantity of other dangerous goods are exported, therefore only cotton shall be discussed in detail.

The procurement agents (buyers) obtain cargo from ginning factories and bring cargo to Thole Produce Yard (T.P.X) area and hand over the cargo to cotton export corporation, which manages the bulk of cotton exports. The cotton can be exported by private parties also.

Exporters or shippers hire clearing and forwarding agents who complete all formalities. The shipping agency books the cargo. The cargo movement is forwarded to Karachi Port Trust (K.P.T) and terminal operators. The fire fighting

arrangements are made by K.P.T. The cargo loading programs are submitted by the shipping agency to mercantile marine department who specifies laid down conditions for stowage on board. Inspections are carried out on board by government surveyors to certify conditions prior departure for safety.

2.6.1. THOLE PRODUCE YARD (T.P.X) AREA

This is a restricted area, located near the port and serves as a warehouse prior shipment. There are few sheds on plinths which mostly are very old. The remaining plinths do not have covered sheds. There is an additional open area allocated nearby known as new T.P.X. The present capacity is for 662376 bales (120432 m.tons). It is connected to hinterland by rail and road.

PROBLEMS

.1. The T.P.X. was designed in 1913 when all the transportation was done by railway wagons. The transport pattern has changed and now 90 % of cargo is brought by trucks, trailers and only 10% by railway wagons. The loaded weight of a truck is 13-15 tons and of loaded trailer about 40-50 tons. They cannot easily maneuver because of narrow passages. Sometimes excess is in such a way that they have to improvise ways by putting planks and bags in between rail tracks to pass the truck or trailer. Occasionally due to excessive load of trailers the rail track gets deshaped or deformed and subsequently causes derailment of engine and wagons.

.2. The approach road widths are very narrow. Only one trailer is allowed and possible to pass. In case of fire,

the fire tender cannot pass through unless the trailer in way moves out which is difficult at times and takes quite a while. The time factor is very crucial in such emergencies.

.3. Most of the cotton bales are not fully covered by hesian cloth, hence fluffs can be seen all over the yard. This is contrary to the rules which require that the bales should be covered with hesian or cloth and that no bales should emit loose cotton. There is a fire hazard with these loose fluffs.

.4. Most of the cotton lies in the open, contrary to the rules which require that they shall be stored in fully covered, solid, fire proof and well ventilated sheds. Godowns constructed or situated at a distance of 45 feet from one another. When the cotton lies in the open, it absorbs moisture from atmosphere in humid conditions specially in the night and if, for long periods it is stored in varying conditions, the chemical, microbial reactions generate heat which may result in rise of temperature or ignition. If condition of heat is hampered due to any reason the chances of ignition of fire increase.



.5. All engines locomotives, trucks, machines as per rules in the restricted area are required to have muffled exhausts to arrest the sparks and excessive smoke but there had been many fires due to none existence of fire arresters on engines as the distance of plinth is not sufficient to prevent the sparks to die out before reaching the cotton bales stowed on the plinth.



.6. Not more than 2000 bales at one time are supposed to

be at east wharf or west wharf area before loading for safety against fire but it is observed that the limit is permitted to exceed at times.

.7. The cotton bales are moved by private contractor's trucks from T.P.X. to east wharf or west wharf for shipment. The trucks earn by the number of trips/bales they carry from T.P.X. to these wharves. The truck drivers being illiterate do not realize the danger and if the cargo is not unloaded immediately then they dump the cargo and rush for the next trip.

.8. The labour and other irresponsible persons are seen smoking sometimes in near vicinity of this cotton in port where stuffing in containers is carried out. No agency arrests them or penalizes them against such acts.

However, there are comprehensive set of rules for the safety, security, storage, and stowage of cotton in the port of Karachi issued by the administration through government notification by statutory regulatory order (S.R.O) 29 (KE9)/72 dated 8th December, 1972. But the actual practices are far from satisfactory and much desired is still to be accomplished.

2.6.2. DANGEROUS GOODS SHED (IMPORTS)

There is a special area on Napier Moll Boat (N.M.B) wharf to receive all the dangerous cargo and is called as Dangerous Goods Shed (D.G. Shed. See Annex IX). It is located on the northern tip of the harbour on east wharf. This used to be a relatively isolated area but as the port grew, it has become an area bristling with activities all around and is not any more an isolated area. This shed is

very inadequate for the dangerous cargo received. In fact the capacity is over utilized. The present D.G. Shed will continue to operate with limited capacity; till such time the baggage shed in adjoining area could be spared for the purpose. Even after, if this baggage shed is acquired, it will hardly be adequate to accommodate the entire quantity of dangerous substances expected to arrive at the port. Moreover, there are no facilities to receive any export commodities in D.G. Shed. It is expected that export cargoes will increase and that will have to be accommodated in D.G. Shed prior to shipment in future.

The D.G. Shed is reasonably equipped with all fire fighting equipment and has 30 automatic dry chemical extinguishers in the ceiling and walls which actuate automatically in case of fire. There is a sub-fire station adjacent to the D.G. Shed. A fire tender is always on stand-by near the D.G. Shed.

DECLARATION AND INWARD PROCEDURE

The port rules require that the master of a vessel through his agent must inform port authorities at least 48 hours prior to arrival, the complete description of dangerous substances as to it's type, quantity and stowage, etc. and same to be confirmed through ship's cargo manifest on arrival.

According to the port rules, all dangerous cargo is required to be discharged overside into K.P.T barges. The barges then come alongside the D.G. Shed where the cargo is discharged and stored before delivery. There are four barges of different capacities from 100 to 300 tons capacity each. One is self propelled and the other 3

barges have to be towed. These barges are unable to cope up with the present demand. Sometimes even country barges are allowed and used. This shortage of barges cause delay to ships. In order to prevent the delay of the ships the operations division of the port has categorized the dangerous substances into four groups:

- Group 1. Very high risk cargo. IMDG class 1 (explosives);
 - Group 2. High risk cargo of IMDG class 2 and 3 (inflammable liquids);
 - Group 3. Low risk cargo of IMDG class 4,5,6,8,9 (inflammable solids, oxidizing agents, corrosives and miscellaneous); and
 - Group 4. IMDG class 7 (radio active material)
- (Baundry, 1988)

The handling of these cargoes is done as follows:

Group 1. Explosives (commercial use). Vessels are not allowed to come alongside the berth. The vessel is moored first on the southern most fixed mooring near the entrance of the harbour. The explosives are then discharged into special explosive barges which will in turn be moored into an isolated area (sandspit channel) pending clearance. The barges are then towed for delivery of cargo to a special area at berth no 24. It is then directly loaded on wagons/ trailers and immediately cleared from the port area. The explosives are not allowed to land on the wharf itself. The whole area is cleared of any other cargo and cordoned off.

Explosives (Defense). In view of various qualities imported in a single shipment, the explosives cannot be handled in normal port rules. The port rules are relaxed

and such vessels carrying defense explosives may be berthed at berth no 21 and 24, west wharf, and the explosives are loaded into wagons or trucks for immediate removal. For this purpose the government of Pakistan has indemnified the Karachi port vide letter No.12/62/80/Log.3 (B-665)/D-4 (A-4) dated 31-3-82 issued by the ministry of defense against all clause damages etc.

(Fazellani, 1985 a)

Group 2. Dangerous cargoes of IMDG Code class 2 and 3 are discharged from ship to over-side barges by the stevedores labour under supervision of K.P.T. inspectors. There after the cargo is handled by K.P.T. labour. The barges are brought near the D.G. Shed and then the cargo is redischarged and stowed into D.G. Shed. Though this process involves double handling of cargo, it is said to be more safe as it avoids congested traffic of the port.

But this process could be argued as it involves double handling and additionally, increases the period of stay of dangerous goods in the port and both factors contribute to additional risks. A closer look, would reveal a number of disadvantages which normally off set the advantages: swell, wind and tide cause ship and barges to move, thus providing unsafe working platforms and occasionally producing sparks; the cargo has to be worked with ship's gear; and barges could be wet and a segregation of the class may be difficult to observe, difficult access for the emergency services in case of an accident. Double handling would also increase costs and a port should provide an economical service to its users. Therefore the Karachi Port Management is well advised to re-examine this practice. Nevertheless, certain dangerous goods would require special loading or discharging place, in

particular some explosives.

Group 3. The cargo is required to be discharged overside into K.P.T. barges, but as there is a shortage of barges, so it is allowed to discharge the IMDG class 4,5,6,8 and 9 cargoes direct into the trucks and then taken to D.G. Shed for storage and subsequent delivery.

Group 4. All radio active material of IMDG class 7 is discharged and given direct delivery to consignee under the supervision of Atomic Energy Commission of Pakistan.



Although dangerous goods are classified in different classes in IMDG Code, the class is not in relation with the degree of danger, but only with the type of danger. There are extremely dangerous substances in all classes, and the degree of danger is indicated either by sub-classes (in class 1) or packaging groups:

- I. High hazard;
- II. Medium hazard; and
- III. Low hazard

EXAMPLES

.1. Explosive substances and articles of class I, division 1.4 are certainly less dangerous than many other substances in other classes.

.2. A tank vehicle carrying liquefied Propylene exploded in Spain (Los Alfaques, July 1978) because it was overfilled. The explosion resulted in fireball some 200 yards in diameter which was so intense than that more than

yards in diameter which was so intense than that more than 150 people in a camp site next to the road were burnt to death. The devastation spread for 400 yards in all directions.

Such an accident would be fatal to a ship or in a port area, while a container of substances or articles of divisions 1.3 or 1.4 would only present a "minor" hazard of explosion, even if involved in a fire, and the fire could probably be extinguished.

.3. Similarly, Methyl Isocyanate class 3.2 is inflammable, highly toxic and may cause explosion and much more dangerous than substances of divisions 1.3 or 1.4. (Bhopal Gas incident)

.4. Hydrocyanic Acid Aqueous solutions class 6.1 are highly toxic substances, specially those which are toxic by inhalation, are extremely dangerous. Although a leakage or a fire would not entail damage to the ship or harbour installations, it would entail the death of many human lives, and on board a ship, of all those who are not using a self contained breathing apparatus at that time, if they breath the vapour.

.5. Organic Peroxide Type B, Liquid class 5.2 is at least as dangerous as a substance of class division 1.3.

.6. Sodium with water (which is likely to occur in a sea environment) may cause explosion of the whole cargo.

.7. Dinitrophenolates, Wetted, Class (4.1). If there is a leakage the substance dries and becomes a division 1.1 substance with a mass explosion hazard. In addition, it is

cargo than many cargoes in class 2 or 3.2.

These examples of various classes show that the way this categorization is done into four groups of IMDG Code Classes is wrong. It is strongly suggested that this Grouping should immediately be cancelled, otherwise, it could cause a disaster.

2.6.4 STORAGE AT DANGEROUS GOODS SHED

Pakistan has adopted the IMDG Code with all amendments and implemented them in September 1973, accordingly the Code has been incorporated in the port rules too. So all dangerous cargo which is brought to D.G. Shed is supposed to be segregated, stacked and stowed in proper compartments according to the IMDG Code. Though efforts are made by the supervisory staff to follow the IMDG Code but due to shortage of space the actual practices observed are far from desirable. Certain cargoes which are supposed to be in separate compartments were seen stowed just few feet away from each other. Some cargoes of class 2 and 3 which were brought by barges, overflowed due to space shortage and seen stowed near the compound wall in the open on loose ground and near by through traffic was passing. Nitro cellulose base compound, highly inflammable, and used in films was lying in the open in ambient temperature where as it should be stowed in cooling compartments. TEL and TML compound drums (anti knocking compound used in petrol in special drums) which are supposed to be one high were seen over stowed by a second tier. For the containers which are brought near D.G. Shed for de-stuffing, no orderly segregation of containers was seen as required by the IMDG code.

D.G. Shed being a transit point the storage of cargo for any length of time is discouraged. Consignees are urged to take quick delivery of their cargo. The demurrage charges are high for the cargo which is not cleared within 24 hours of landing. The average period of goods remaining in D.G. Shed is about 5 to 6 days. But there are cases where goods stay for longer periods of even about 6 to 8 weeks, mainly because of custom formalities, documentation, etc.

2.6.5 CARBIDE HUTS

It is located in Mansfield Yard (M.I. Yard) at West Wharf. These huts are specially designed with reinforced concrete structures with blast proof capability. The calcium carbide discharged from ships is stowed here pending clearance.

2.6.6. DAMAGED DANGEROUS GOODS

The port does not accept any damaged packages of dangerous substances as a safety measure. The damaged packages are retained on board until repaired or leakage stopped. Then these packages are surveyed and certified for acceptance by a surveyor. Badly damaged packages are generally rejected. This practice endangers the safety of a ship which has much more limited resources than the port itself and is contrary to the norms of an efficient port.

2.6.7. FIRE FIGHTING

The port has a very efficient fire fighting unit. There are seven fire stations located at suitable points and provide complete coverage of Port and adjoining areas.

- The fire fighting unit has sufficient fire tenders (water, foam and dry powder type), foam monitors of 200 gallons, mobile foam units of 40 galls, high expansion foam generator, mini high expansion foam generator.
- Carbon di oxide (CO2) installations in power houses and in all sub-stations.
- Each workshop, shed, office is protected by various types of fire extinguishers. About 5000 fire extinguishers are maintained.
- Anti contamination protective clothing, fire fighting suits, self contained breathing apparatus, etc.
- Towing vehicle and special equipment carrier.
- Multi jet foam inductors, Variable in-line foam inductors.
- Light trailer pumps, Heavy trailer pumps.
- Hydraulic platforms, Light fire engine.
- Fire fighting snorkel to reach a height of 85 feet.
- Sabil is a fire fighting floating unit. It can operate up to 50 miles at sea. It is a complete fire fighting station with a capacity of 5000 gallons Of foam (protein foam).
- Fire hydrants are available at every 50 feet distance throughout the port.
- A ring main system exists in the T.P.X. area which remains pressurized from the over head tank of 40000 gallons capacity. About 172 hydrants are installed at suitable distances on the ring main system. This ring main system is further extended to new T.P:X. area with an addition of 32 hydrants.
- A ring main system is also on East Wharf with 308 fire hydrants, suitably spaced on all plinths and roadways.
- An automatic ring main system has been installed in the West Wharf with 90 fire hydrants from berth 21 to 24 suitably spaced. Additional hydrants are added to the

system extending to other berths.

- Radio fire alarm system have 80 points located in port areas and T.P.X. and if at one point the button is pressed the alarm goes on with light indications on board and sound activates on V.H.F. system of fixed and mobile units.
- Elaborate fire fighting arrangements have been provided on Oil piers as well. However, aquas film forming foam (AFFF) is not available at the moment.

2.6.8. DEVELOPMENT PLANS OF KARACHI PORT

The current development plan for the port is the 5th development project and is known as Western Backwaters Complex (See Annex X). It is planned to build a modern container terminal here. A peripheral trunk road is also planned to be built under this scheme which will connect it directly with Super Highway (main highway) and thus shall have direct access to inner part of the country.

The operation department responsible for handling of all cargo in port area realized the difficulties and problems of dangerous substance handling and stowage at D.G. Shed and had drawn the timely attention of the planning and development division of the port and had suggested to keep provisions while under taking the works of fifth development project (Western Backwaters Complex) for a suitable dangerous cargo jetty associated with a suitable warehouse for handling the dangerous cargo. But it seems that no serious consideration is given to their suggestion as apparently there does not exist any such plan.

Secondly, cotton is the main export and main foreign exchange earning component. Yet no plans are made to

re-develop the T.P.X. of which conditions are explained earlier.

In brief the planning and development division of K.P.T. has not kept any provisions in their development plans for dangerous substances, neither for exports nor for imports.

2.6.9. FIRE ACCIDENTS/INCIDENTS IN KARACHI PORT AREA

.1. There was a serious fire in Dangerous Goods Shed in 1977. The fire was in Dinitroso Penta Methylene Tetramine (D.P.T) drums which is used as a blowing agent in rubber industries. Apart from the loss to property and cargo worth millions of rupees, there was great danger to general public residing in the vicinity due to explosion and chemical reaction caused by fire. The thick clouds of smoke, a combination of mixed chemicals, endangered public health and caused panic among them (T/C-6/33/1390 dated 12.2.1981)

.2. Fires in T.P.X.

Year	No of cotton bales Damaged	Approximate value.
1983	300	Rs. 1500000
1984	82	Rs. 410000
1985	2731	Rs.13655000
1986	1104	Rs. 5520000
1987	12	Rs. 60000

(The value of one bale is taken as Rs.5000 approximately)

(Statistics from T.P.X. records)

.3. Fires in T.P.X. and port (see Annex V)
(from K.P.T. Fire Service Station records)

These incidents reflect the way we manage our port. Even these figures go nowhere describing, what is actually happening in our port but do go a long way in describing that something might be seriously wrong. The losses of cargo and property in recent years should give us all reason to pause and reflect as just what must be done. What is more disconcerting is the fact that when comparing these practices found in the other ports of the world with that of our own port, it seems to me to be a very large difference in concept and practice. The above tables give some idea of what we are faced with. These losses should be unacceptable to us and lessons must be learnt from these incidents. (See Annex VIII)

2.7. PROBLEMS OF KARACHI PORT

.1. General

As noted by Karsten Brunings (1988 a) in his paper on "Personnel training in the transport of dangerous goods in port of developing countries", the port of Karachi like any other port in a developing country has faced three major influencing factors in the last three decades which have had a decisive effect on the safe transport, handling and storage of dangerous substances:

- There have been drastic changes, innovations and developments in maritime transport technologies, e.g. containerization and other types of specialized ships to carry special port handling facilities;

- Advancement in technologies especially in the chemical field have caused an enormous increase in different types of chemicals, also their qualities and other dangerous substances carried at sea.
Another problem which became chronic is lack of skilled labour and the lack of specialized training of port personnel at all levels to meet the challenges of new technologies; and
- Extensions of ports very often change the general layout of the port which mostly do not conform to the original planning. This sometimes changes the utility concept of certain areas within the port, i.e. an isolated remote area of port used for dangerous cargo became the center of operational activities and thus became unsuitable for that purpose. These factors caused problems. Now in order to keep the port in competitive operational conditions the port management had concentrated the port investments in adoption to these changes in technologies and left safety matters to secondary interest or over looked.

.2. Specific Problems:

- Out dated Government and port regulations;
- Inadequate legal framework and administrative procedures;
- Hesitation on the part of officials responsible for proposing legislation and framing regulations (because of encountering enormous difficulties in the process) to propose new legislation/regulations to meet the modern demands.
These points about legislation/regulations shall be discussed in detail in the next chapter;
- Lack of awareness on the part of port policy makers and

planners;

- Extension of port which was not in line with the original planning;
- None availability of special training programs;
- Unskilled and illiterate labour/transporters;
- Out dated storage and transport facilities at T.P.X;
- Improper location and lack of storage facility at D.G.Shed;
- No facility to accommodate export commodities of dangerous substances in D.G. Shed, i.e. sulphuric acid, etc;
- No safety department. No safety officer with any judicial powers;
- No contingency plans;
- No stowage plan or manifest is provided to port fire service, to know the nature of cargo and the type of fire to be fought in case of an emergency;
- Use of other barges specially the country craft; and
- Country craft loading cotton in vicinity of D.G. Shed and fluffs scattered all around.

CHAPTER 3

LEGISLATION

3.1. PURPOSE OF LEGISLATION

The purpose of legislation for the carriage of dangerous substances is to provide the legal framework to conduct operations in a safe manner for:

- The safe transportation, handling, and stowage on ships and in ports;
- To fulfill her legal obligations as a port state and as a flag state;
- To facilitate foreign trade; and
- To achieve part of a country's economic objectives.

To achieve these objectives:

It is necessary to regulate the relationship of all parties involved in maritime transport. Thus rule should cover all concerned interests, i.e. safety of port, cargoes, ships, and all personnel involved in transportation, handling and stowage. For this purpose, it is important that a state adopt laws on two aspects:

- .1. The safe transportation, handling and stowage in ports; and
- .2. The carriage of dangerous substances by various types of ships.

Finally, it is important to provide for rules of procedure, e.g. the detention of vessels for non compliance as a measure of safety and to solve other

possible conflicts between the parties involved, etc.

The purpose of laws and regulations for the transportation , handling and stowage of dangerous substances can only be achieved with adequate knowledge of these regulations by all parties concerned. It would then enable them to discharge their individual responsibilities with utmost care and would mean an effective implementation.

Thus in brief these laws would then enable a country to achieve her economic objectives, carrying out of her trade, comply with her legal obligations and achieve safety of port, ships, environment and personnel involved in transportation, handling and stowage.

3.1.1. LEGISLATIVE STRUCTURE IN DEVELOPING COUNTRIES.

Developing countries lack the legislative structure. The old legislation/regulations for the carriage of dangerous substances were made to serve the needs of that time with conventional ships, small ports, and very little variety of dangerous substances. In the first half of this century international maritime law in the form of international conventions, protocols, and other legal instruments were not so much in existence as today and a country did not have to comply with so many legal obligations.

The present concept and mode of maritime transport has been totally changed by various types of specialized ships, special purpose built ports, i.e. container terminals, oil terminals, etc. requiring specialized handling facilities and in addition large quantities of ever evolving new dangerous substances.

In order to cope with the demands of these modern developments various international conventions, protocols, and other legal instruments have come into existence, making it obligatory for compliance by parties to these conventions. This could only be achieved by making them a part of a national legislation in one form or the other.

The old legislation/regulations which usually contained provisions for explosives and petroleum to a limited extent are totally outdated. Therefore the handling operations and storage practices which are based on outdated administrative and regulatory procedures have to be updated or changed. In all fairness any administration with lack of adequate legal support can not achieve safety and efficiency in transportation, handling and stowage of dangerous substances. Karsten Brunings (1988 a) noted in his paper that, "Developing countries and their ports often lack the legislative, educational and administrative structure which would enable them to keep pace with the presently experienced radical changes of technology".

So there is a need which could not be over emphasized that a country should have a legislative frame work and upto date regulations for her ports and ships to meet the present day requirements and the two must have compatibility and harmonization to meet her legal requirements and smooth operational practices.

3.1.2. DRAFTING OF NEW LEGISLATION

Maritime administrations of developing countries must fulfill their obligations/responsibilities and draft either new appropriate legislation or revise/update the existing one for the carriage, handling and stowage of

dangerous substances which subsequently should be followed by a subsidiary legislation for details and application. International conventions provide material which may be adopted into national legislation. Additionally examples could be followed from maritime legislation for dangerous substances in other countries. Care must be taken that foreign laws are not necessarily designed to serve the same purposes. A foreign law may be very clear, complete and consistent; yet there is no guarantee that it will serve the national objectives.

3.1.3. BASIC APPROACH FOR LEGISLATION

It is important that relevant policy issues are clearly defined and brought into line before drafting any new legislation for the carriage of dangerous substances. This will help the policy makers to set their priorities, and if required, establish a hierarchy of policy objectives. This will provide required consistency of both policy and law and therefore prevent situations whereby a particular law serves a particular policy objective, but runs counter to other objectives.

After the policy has been developed the question would be whether the policy requires a legislative action or not. The answer would then depend on the country's legal system and the policy matter at stake.

It would be an advantage, if the approach is systematic and to avoid as much as possible an ^{Temporary} ad-hoc legislation designed for problems at hand. An ad-hoc legislation usually inhibits an overall policy and may create just the situation of serving an objective while running counter to another. Additionally, its existence may be impediment to

future legislation.

The legislation for dangerous substances of a country can either be made in the form of a code or alternatively by separate acts. A code has the practical advantage that all provisions are contained in a single text and available for easy reference and consultation. But drafting of a code is an elaborate job and requires time and this may cause delay in passing the legislation by law makers.

Separate acts have the advantage that legislation can be enacted quickly for subjects which require urgent attention. But this method has the problem in practical application as the legislation and regulations are scattered in bits and pieces which makes it difficult to find which acts are in force and which acts have been repealed or substituted. However, if this system already exists, then it would be advisable that each separate act be prepared according to a coordinated maritime legislative program and different subjects be dealt with in an agreed sequence.

In both cases it would be advisable to separate the basic provisions which should be embodied in primary legislation (Act) and for technical details and practical application it should be covered by a secondary legislation (regulations). This has an advantage that the regulations can be amended and updated as and when required without having to amend the primary legislation.

Many countries due to enormous complication have decided to resort to the former method, by making comprehensive sets of regulations passed by an act and this act would then replace all the old acts. Once passed and enforced,

this becomes more practical and simple for easy reference. To make these regulations more understandable and simple the administration further issues guidelines to these regulations which are easy and simple to understand and could easily be followed by all parties involved in the carriage of dangerous substances. United Kingdom can be quoted as an example which has enacted an act in such a way.

"The Dangerous substances in Harbour Areas Regulations 1987", which came into force on 1.6.1987. These regulations are further clarified in a booklet "A Guide to Dangerous substances in Harbour Areas Regulations 1987". This publication HS(R)27 is from the Health and Safety Division.

Then there is a booklet "An Approved Code of Practice for the Dangerous Substances in Harbour Areas Regulation 1987" This code has been prepared following joint discussions between representatives of the confederation of British Industry, the Trade Union Congress, local authorities, The British Ports Association, Government Departments and the Health and Safety Executive (HSE).

To supplement further, there is another booklet "Guidelines for Safe Warehousing". This publication is from Chemical Industries Association for safe warehousing of hazardous substances. These publications all together are very comprehensive, easy for reference and could be followed as a model.

3.1.4. LAW AND CONVENTION

If the law is related to areas covered by an international

convention then it should be drafted to facilitate possible adaptation and implementation of those conventions and their subsequent amendments. In the adaptation of a convention two situations may occur:

- According to monastic view of international law, the convention becomes part of the law through the act of ratification or accession. Principally the implementing regulation required is then limited; and
- In the dualistic concept of international law, the convention becomes part of the national legislation only after full scale implementing legislation has been adopted.

Again the matter may be different depending on the convention. Some conventions contain self executing provisions, i.e. the obligation there in rests on the private parties in a state party to the convention, once the convention has entered into force. Therefore, in principle no implementing legislation is required for self executing provisions to become binding on all concerned nationals. It is prudent to consider this while ratifying of a convention and its subsequent implementation. It could be possible that an international convention may not be self sustaining, in which case it is necessary to enforce rules so as to render the convention fully applicable. If separate national legislation is needed for implementation, then the best way would be to annex to the act the technical rules adopted under the relevant convention as a schedule to the act. This would then facilitate the incorporation of subsequent amendments to the convention into national legislation. But the approach may not be feasible in all legal systems. Other possibilities could be to draft subsidiary legislation in

which the technical rules are incorporated. In order to facilitate the future adaptation of the legislation to amendments of the convention, it would be advisable to change as little as possible in substance and order of the technical rules of a convention when incorporating them in national legislation. (Economic and social Commission for Asia and Pacific, 1984)

3.1.5. JURISDICTION

When the laws and conventions are considered then the concept of jurisdiction has to be clearly understood. Jurisdiction have different concepts in private international law and in public international law.

In private international law, jurisdiction refers to the question which court in which country may adjudicate a case and which law applies to the case.

In public international law, the legislative jurisdiction denotes the power of a state to set rules on certain matters and persons, and enforcement jurisdiction denotes the power a state has to enforce the national regulations including the power of physical interference and the competence of a state's courts to prosecute violation. It is hardly possible that a country would have enforcement jurisdiction without legislative jurisdiction. The enforcement jurisdiction emphasizes the power to enforce rules set by a country, which rule could only be enacted if a country has the power to do so, i.e. legislative jurisdiction.

3.2. CURRENT LEGISLATION/REGULATIONS

The handling of dangerous substances in the ports of Pakistan is governed under six different pieces of legislation. These are:

- Explosives Act 1884 (IV of 1884);
- Port Act XV of 1908;
- Petroleum Act 1934;
- The Dangerous Cargo Act 1953;
- Merchant Shipping Act 1894; and
- Merchant Shipping (amendment) Act 1923.

The government, under the powers conferred by these acts, makes regulations and enforces them through gazette notification. These regulations are usually in the form of statutory regulatory order with a serial number.

3.2.1. EXPLOSIVE ACT 1884 (IV of 1884)

According to section 4 of the Pakistan Explosive Act 1884 the term "Explosive" means :-

Gun Power, Nitro Glycerine, Dynamite, Gun Cotton, Blasting Powder, Fulminate of Mercury or of other metals, Coloured fires, and every other substance whether similar to those above mentioned or not, used for manufacture with a view to produce a practical effect by an explosion, or a pyrotechnic effect and includes Fog Signals, Fire Works, Fuse Rockets, Percussion Cap Detonator, Cartridges, Ammunition of all descriptions and every adaptation or preparation of any explosive as defined above and as mentioned in the IMDG Code.

Section 5 of Explosive Act 1884, empowers the Government to promulgate regulations. The Ministry of Industries by notification No 1(11)-8(7)/54 dated 17th September, 1954 made rules relating to the transportation and importation of explosives in the port of Karachi and are called "The Karachi supplementary rules 1954". The rules are in addition to Karachi supplementary explosive rules, 1940. The provisions of the rule contain which in brief are:

- The rules apply to Port of Karachi and shall come into force at once;
- Specifies that provisions of the rule shall not apply to safety cartridges, Chinese crackers, magic wire magnesium, brilliant matches and candles, etc;
- The Master is to give 48 hours notice prior to arrival and is to submit a written declaration in case weight exceeds 100 lbs;
- Vessels loading or discharging explosives in excess of 100 lbs shall be berthed at an explosive's mooring;
- Explosives in transit can be retained on board if magazines are properly constructed and approved by surveyor of mercantile marine department, with a police guard to be on board and the key of the magazine to be with the port authority;
- Vessels should display signals; by day a red flag and by night a red light. Additionally all barges and vessels are required to carry on deck a buoy 1.75 feet in length 1.11 feet in diameter with 15 fathoms of rope;
- Explosives in boats shall be carried in approved decked boats and weight not to exceed 25 tons at any one time in the boat; and
- Explosives shall only be landed at, loaded from or deposited upon lighterage wharf no 22 or such other

specified space.

(The Karachi Port Trust Manual, 1981)

Explosives in class 1 are subdivided into 5 classes according to the hazards and are further divided into 12 Compatibility groups. There are altogether 34 classification Codes. Figures 1.1, 1.2 and 1.3 are Flow charts which show how the classification is done. The Compatibility group to a substance is assigned by UN Committee of Experts on the basis of tests and criteria. The explosives of today are complex and require special rules and regulations. The contents of Annex I will indicate the complexity and the various special measures required in transportation and handling of explosives.

As can be seen, the above mentioned regulations only set the parameters for operations in a very general sense and do not deal with explosives in any depth as required for explosives with different sub-divisions of today. Hence these regulations are totally outdated.

Many points need further consideration and among them are a few mentioned below, i.e. after taking into account the existing Explosive rules, IMDG Code and K.P.T manual:

- .1. Specific requirement for the handling of explosives should be established, having regard to the hazards involved and the population density in the vicinity of the port area and any other relevant circumstances.
- .2. Regulations to differentiate handling with reference to compatibility and hazard division.

SCHEME OF PROCEDURE FOR CLASSIFYING A
SUBSTANCE OR ARTICLE.

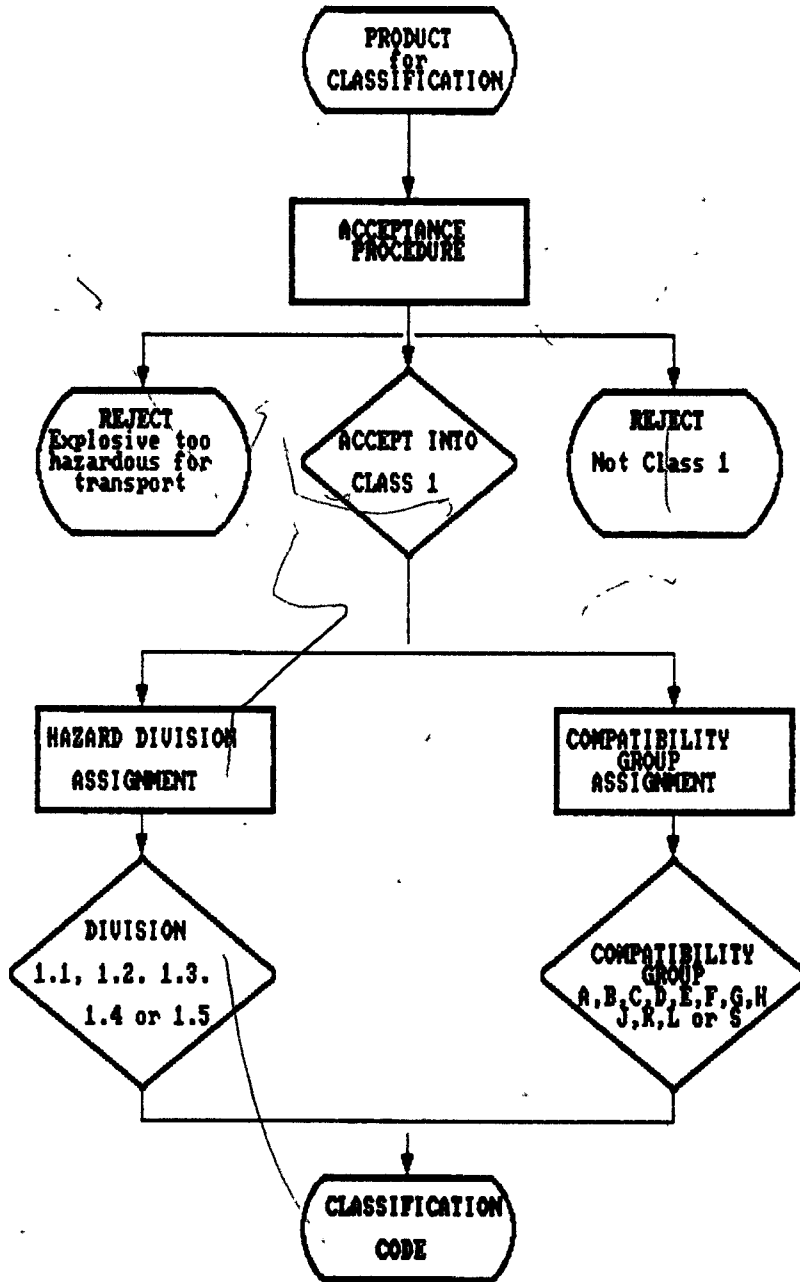

Figure 1.1

Acceptance procedure

The acceptance procedure is used to determine whether or not a product as offered for transport is a candidate for Class 1. This is decided by determining whether a substance is too insensitive or too sensitive for inclusion in Class 1 or whether the article(s) or packaged article(s) are too sensitive for Class 1

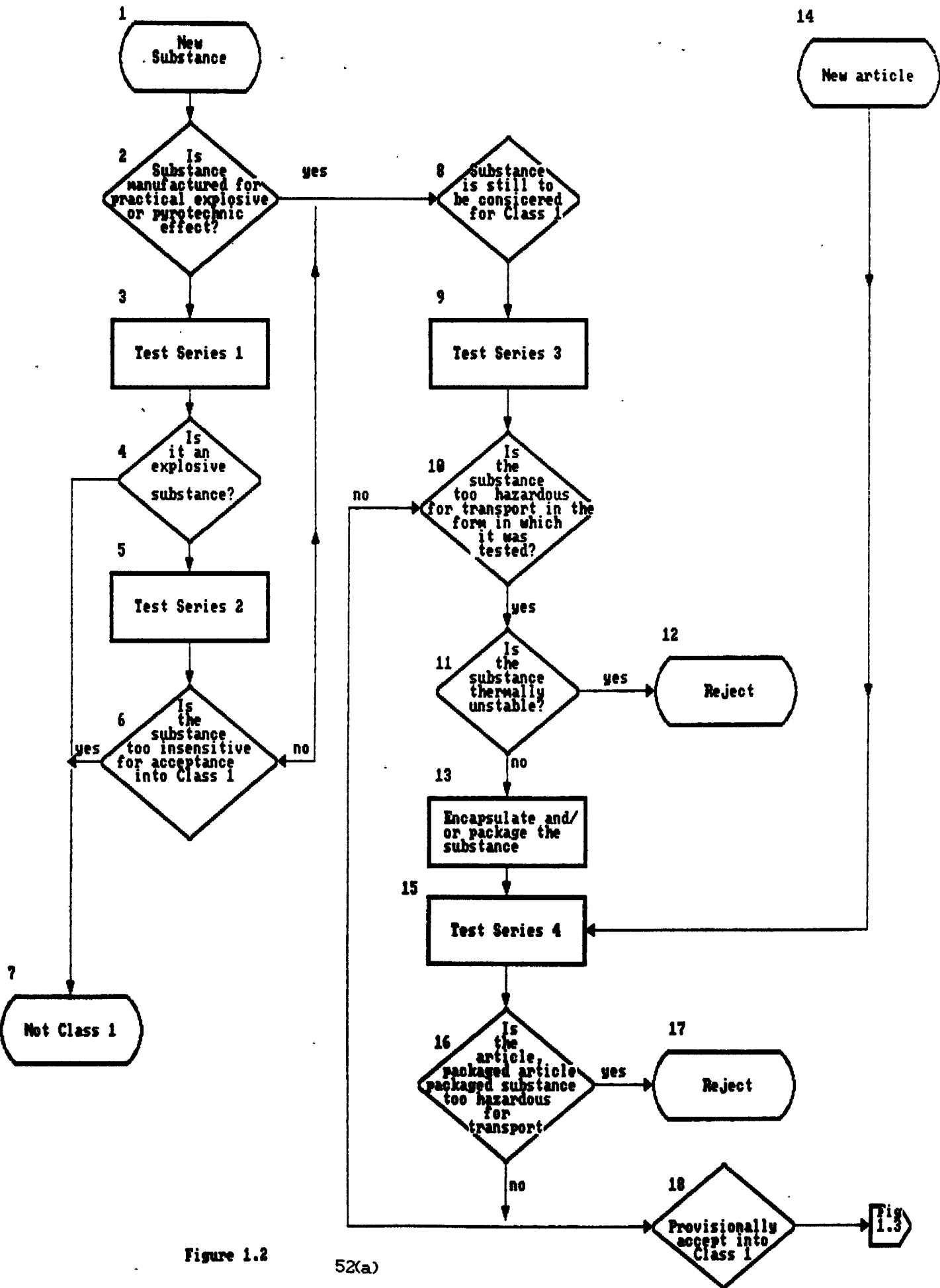

Figure 1.2

52(a)

Procedure for assignment of hazard division

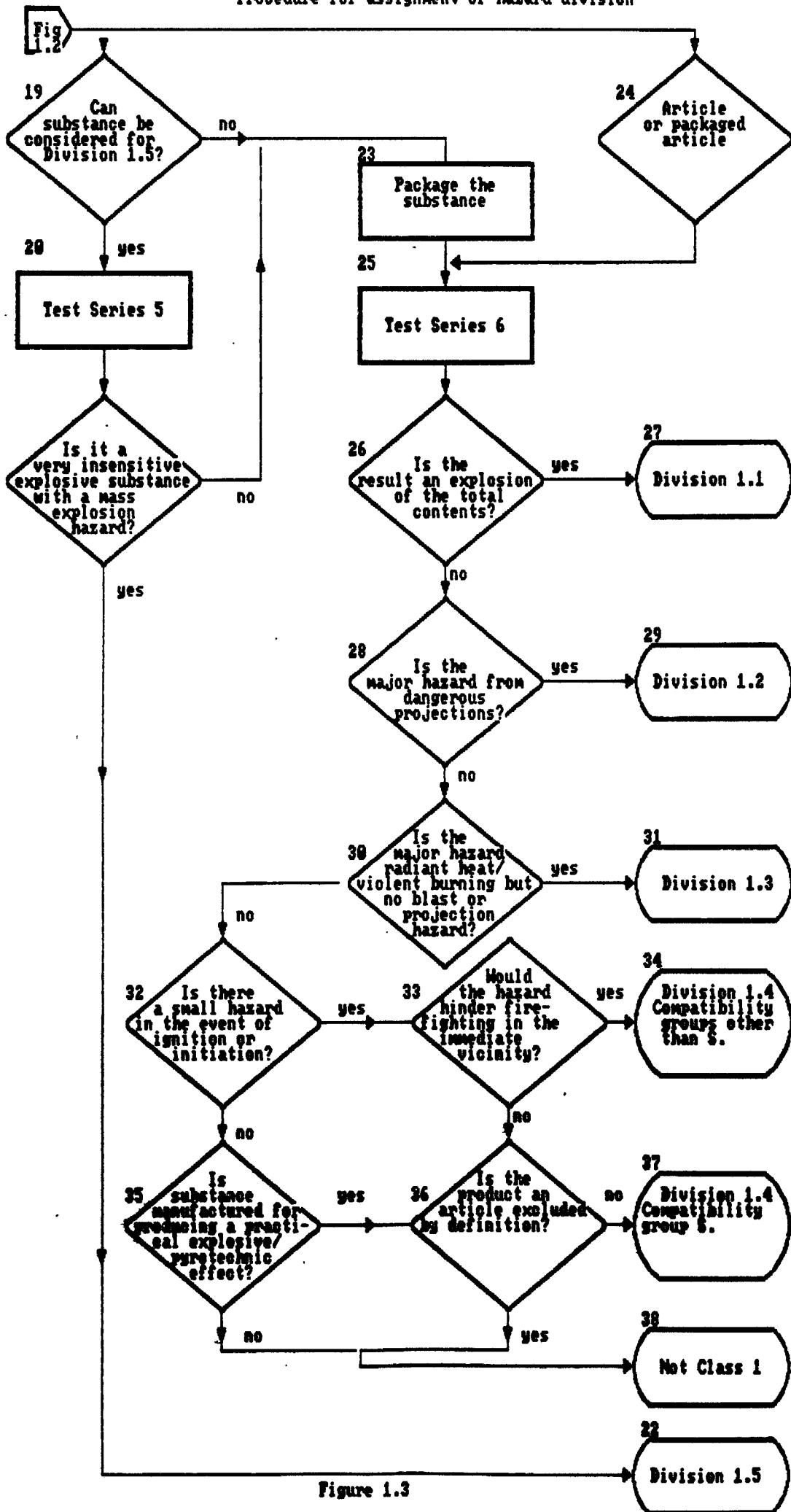

Figure 1.3

- Explosives of compatibility group L not to be handled without a license in port area;
- Explosives of Compatibility group A,B,C,D,E,F,G,H, and K not to require a license unless the total quantity of explosives exceed 10 Kilograms; and
- Explosives of Compatibility group S and hazard division 1.4 shall not be required to have a license.

.3. Handling of deteriorated Explosives.

Because of the sensitivity of many explosives, special conditions should be considered and agreed before any explosives, which for any reason may have deteriorated or undergone a change of condition that may materially increase the hazards attended upon their conveyance or handling, are moved in the port area. Such special conditions should be agreed in written between the designated port officer and the responsible person having charge of the explosives. (IMO Publication, 1983)

.4. Electro explosive devices not to be allowed in port unless so constructed and packed as to be safe for carriage.

3.2.2. PORT ACT, 1908 (XV of 1908)

Under the powers conferred by this act, the Federal Government through gazette notification of the ministry of communication (ports and shipping wing) usually issues a statutory regulatory order while framing or amending any regulation concerning the port.

- Explosives of compatibility group L not to be handled without a license in port area;
- Explosives of Compatibility group A,B,C,D,E,F,G,H, and K not to require a license unless the total quantity of explosives exceed 10 Kilograms; and
- Explosives of Compatibility group S and hazard division 1.4 shall not be required to have a license.

.3. Handling of deteriorated Explosives.

Because of the sensitivity of many explosives, special conditions should be considered and agreed before any explosives, which for any reason may have deteriorated or undergone a change of condition that may materially increase the hazards attended upon their conveyance or handling, are moved in the port area. Such special conditions should be agreed in written between the designated port officer and the responsible person having charge of the explosives. (IMO Publication, 1983)

.4. Electro explosive devices not to be allowed in port unless so constructed and packed as to be safe for carriage.

3.2.2. PORT ACT, 1908 (XV of 1908)

Under the powers conferred by this act, the Federal Government through gazette notification of the ministry of communication (ports and shipping wing) usually issues a statutory regulatory order while framing or amending any regulation concerning the port.

The powers conferred by section 5 of Port Act, 1908 (XV of 1908) the Government through notification no. 12-P (85)/39-1 dated 2nd May, 1940 defined the Karachi Port limits.

The powers conferred by clause (a) to (c) of sub section (1) Of section 6 of Indian Port Act, 1908 (XV of 1908), the Federal Government through notification of Ministry of Communication dated 1.10.1984 issued Statutory Regulatory Order 43 (KE)/84, incorporating the IMDG code in Karachi port rules. The same having been previously published as required by sub-section (2) of said section, namely:-

In the aforesaid rules, after rule 91- A, the following rule inserted:-

"91- B". All dangerous goods shall be handled at the port of Karachi as per IMO International Maritime Dangerous Goods Code (IMDG Code) Classifications, as amended from time to time, in accordance with the following rules:-

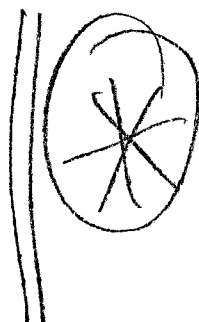

.1. Class 1 category goods pertains to the explosives only and shall, as at present continue to be discharged at Berths no 24 and 21 which berths are indemnified by the Government.

.2. Dangerous goods of class 2 and 3 which pertain to inflammable liquids and gases should continue to be transported to the dangerous goods shed here-in-after in this rule referred to as D.G. Shed, by barges only.

.3. Dangerous goods of class 4, 5, 6, 8 and 9, if in containers (20 feet or 40 feet FCL or LCL) may be transported to D.G. Shed direct by trucks or trailers except dangerous cargo having Flash Point below 91 degrees F which may be transported by barges only.

Full text of rule 91-B is shown in Annex VII.

The Karachi Port Trust is an autonomous body and is run by a Board, which also has the powers under the same Port Act of 1908 to make any bye-laws for its working procedures, administrative rules, etc. The K.P.T. manual designed for the traffic department was approved by the K.P.T. Board vide resolution no. 391 dated 31.12.1970. The manual was initially compiled from the rules and regulations contained in various authorised publications and departmental orders/circulars issued from time to time. The manual contains the procedures and practices followed by the traffic department and there are six chapters on dangerous substances.

Chapter XVIII deals with dangerous/hazardous goods excluding explosives and petroleum. This chapter covers:

- .1. Definitions of dangerous goods;
- .2. Dangerous cargo register to maintain the record of dangerous cargo; and
- .3. Procedures for landing and shipment of dangerous goods in Karachi port is laid down in rule 91 (a) framed under the Port Act (XV) of 1908 duly amended which contains in brief:
 - The master of an arriving vessel shall declare the dangerous goods, display the signals, make arrangements for K.P.T. barges to discharge cargo and all such goods shall be transported to N.M.B. wharf or places as the traffic manager may generally direct. In

the event of a K.P.T. barge not available for the above purpose the traffic inspector will make arrangements to discharge the goods into other barges then to be discharged at D.G. Shed;

- Vessels with dangerous goods to proceed to wharf or swinging mooring subject to the conditions laid down under the rule;
- 48 hours notice before arrival of dangerous goods either from sea or inland;
- The agents of vessel and the owners of boats and barges are responsible to comply with the regulations; and
- Other general provisions to include precautions against pilferage of dangerous cargo, reception of dangerous goods into patrol barge, storage of dangerous goods, preparation of landing report, delivery of dangerous goods and examination of dangerous goods.

(Fazellani, 1985 b)

Chapter XIX deals with Arms and Ammunition. The provisions are for landing and shipment of packages of arms and ammunition, care to be exercised in unloading and storage of calcium carbide in the carbide hut.

Chapter XX deals with handling of calcium-carbide. The provisions contain a preliminary note for procedures of handling of the calcium carbide on the wharf. The precautions prescribed under Government notification general department no 2692, dated the 4th May, 1906.

Chapter XXI deals with handling of matches. The provisions contain for discharging, subject to the provisions of Bye-law no 6 of the K.P.T. General Bye-laws for packages

containing matches, process of discharge, demurrage dates documentation and delivery.

Chapter XXII deals with the handling of Explosives which has already been discussed.

Chapter XXIII deals with the handling of Petroleum which shall be mentioned later.

The manual is basically designed for the operational requirements for the staff of traffic department and serves the purpose well. It can be said that it is more of a commercial oriented nature, i.e. dealing with discharge, delivery, demurrage, documentation, etc. But it lacks in technical depth as the regulations mentioned there in are mostly outdated. However, it does not pre-empt the excellent work put into the manual otherwise. In fact this is the only comprehensive document where most of the regulations are compiled together. It could have been a very useful document, if the regulations mentioned there were not outdated.

3.2.3. THE DANGEROUS CARGO ACT, 1953.

An Act (to make further provisions) the safety of ports in respect of the transit, working and storage of dangerous cargoes and matters incidental there to;

Where as it is expedient (to make further provisions for) the safety of ports in respect of transit, working and storage of dangerous cargoes and matters incidental there to;

It is hereby enacted as follows:

- .1. (1) This act may be called the dangerous cargoes Act, 1953;
- (2) It extends to whole of Pakistan; and
- (3) It shall come into force at once;

.2. In this act:

(1) "Dangerous cargoes", means any cargoes containing;

- (a) Any goods shown as explosives which are included in the classified list of Government Explosives compiled and issued by the Explosive Stowage and Transport committee which has been accepted and approved by the Central Government or any ammunition; or
- (b) Petroleum as defined in clause (a) of section 2 of the Petroleum Act, 1934, when the flash point (F.P) of such petroleum is below 150 degrees Fahrenheit (XXX of 1934);
- (c) Prohibited dangerous goods, which are classified as dangerous in the Government Stowage Industries as revised from time to time by Board of Trade or the Ministry of Transport in the United Kingdom and accepted, modified or supplemented by the Central Government; or
- (d) Any cargoes which are liable to fire or explosion and which are declared by the Central Government by notification in the official Gazette to be dangerous cargoes for the purpose of this Act.

(2) Definition of Fortress Commander.

- .3. The Central Government may make such orders as appears to it to be necessary or expedient for securing the safety of any port and preventing or dealing with explosions and fires on vessels carrying dangerous cargoes within the limits of any port, and generally for the transit working and storage of dangerous cargoes and matters incidental there to.
- .4. (1) The Central Government may by notification in the official Gazette, make such rules as appear to it to be necessary or expedient for carrying the purposes of this Act into effect.
- (2) Without prejudice to the generality of the foregoing power such rules may provide for all or any of the following:
- (a) The constitution, mobilization, enrollment, discipline, equipment, duties, privileges and protection of fire brigades and fire services in or near any port;
- (b) The powers to be conferred and duties to be imposed on any officer or authority for the purposes of this Act; and
- (c) The mobilization and control of any Government, State or Municipal service, or private organization, by the Fortress Commander in the event of the declaration of any emergency or apprehended emergency due to fire or explosion.
- .5. Declaration of an emergency.
- .6. Powers of the Commander-in-Chief of the Pakistan navy.
- .7. Delegation of power by Commander-in-Chief of the Pakistan Navy.

.8. Powers of deputy Conservator of the port.

.9. (1) Any contravention of or attempt to contravene, and any abetment of or attempt to abet the contravention of any provision of this Act, or the rules made thereunder or any order under this rules shall be punishable with imprisonment for a term which may extend to two years or with fine which may extend to five thousand rupees or with both.

(2) For the purposes of this section failure to obey the the provisions of any rule or order under this Act shall be construed as a contravention of the rule or order.

.10. The police may arrest without warrant any person committing an offense under this Act.

.11.(1) No order made in exercise of any power conferred by or under this Act be called to question by any court.

(2) When an order purports to have been made and signed by any officer or any authority in exercise of any power conferred by or under this Act the court shall, within the meaning of the Evidence Act, 1872, presume that such order was so made by that officer or authority.

.12. Protection of action taken under this Act.

(Manager Publications, 1967)

The regulations for the handling of cotton in the port

area are also made under this act, which stipulate:

The powers conferred by section 3 of the Dangerous Cargo Act, 1953 (v of 1953) , the Government through notification of Ministry of political affairs and communication (Directorate General of Ports and Shipping) issued Statutory Regulatory Order S.R.O 29 (KE) 72, for the safety, security, storage and stowage of cotton/other goods in the port of Karachi.

These are very comprehensive set of regulations and all aspects for cotton handling in port area including T.P.X. are nearly covered.

3.2.4. THE PETROLEUM ACT 1934 (XXX OF 1934)

An Act to consolidate and amend the law relating to the import, transit, storage, production, refining and blending of petroleum and other inflammable substances. The act is further supplemented by petroleum rule 1937.

The subject of petroleum is briefly mentioned here as it is not within the scope of this work. However, it was necessary to mention as legislation has to be mentioned in the context of dangerous substances to point out the missing requirements. The rules as described in K.P.T. manual for the handling of petroleum are very outdated and extensive improvements are desirable, i.e. the regulations do not cover requirements for the fitness of the vessel with reference to, "IMO Code of Safe Practices for Solid Bulk Cargoes", "Gas Carrier Code for existing Ships", "IMO Code for the Construction and Equipment of Ships carrying Dangerous Chemicals in Bulk", "IMO Code for the Construction and Equipment of Ships Carrying Liquified

Gases in Bulk".

Though Pakistan is not yet a party to to MARPOL 73/78 convention which require the above mentioned codes but IBC and IGC codes are also mandatory for new ships under SOLAS 74 regulation 2/54 and chapter VII. Since Pakistan is a party to SOLAS 1974 Convention, so the fitness of the vessel under SOLAS 1974 has to be covered.

3.2.5. MERCHANT SHIPPING ACT 1894.

The carriage, handling and stowage of dangerous goods on board ships are done under the Merchant Shipping Act. The first act which dealt with dangerous goods was British Merchant Shipping Act 1894 of which Art 301 states:

- .1. Subject to the provisions of this part of this Act as to military stores, an emigrant ship shall not clear outwards or proceed to sea, if there is on board:
 - (a) as cargo, any article which is an explosive with in the meaning of the Explosives Act, 1875, or any vitriol, lucifer matches, guano, or green hides, or
 - (b) either as cargo or ballast, any article or number of articles which by reason of the nature, quantity, or mode of stowage thereof are; either singly or collectively, in the opinion of the emigration officer at the port of clearance, likely to endanger the health or lives of the steerage passengers or the safety of the ship, or
 - (c) as cargo, horses or cattle or other animals mentioned in the Thirteenth Schedule to this Act, except they

are carried on the conditions stated in that schedule, which shall have effect as if contained in this section.

.2. If any requirement of this section is not complied with in the case of any ship, the owner, charterer or master of the ship or any of them, shall for each offence be liable to a fine not exceeding three hundred pounds.

This Act is still in force in Pakistan and occasionally referred as the mother Act. Various amendments to this Act were made, which are in the form of Merchant shipping (Amendment) Act 1923.

3.2.6. MERCHANT SHIPPING (AMENDMENT) ACT 1923.

The amendments made in Merchant Shipping (Amendment) Act, 1894 are described in this Act. So the amendments are in fact regulations in addition to Merchant Shipping Act of 1894.

Sections 225 and 226 of Merchant Shipping Act, 1923 are substituted by section 12 of Act, 8 of 1954 (Amendment to dangerous cargo Act 1953). This came into force from 1.5.1967 vide S.R.O (K) 167 dated 15.4.1967. Section 225 deals with the carriage of dangerous goods and states:

"225. (1) The central Government may make rules for regulating in the interests of safety the carriage of dangerous goods in ships to which this section applies;

(2) This section applies to:

(a) Ships registered in Pakistan;

- (b) Other ships while they are within any port in Pakistan or are embarking or disembarking passengers within the territorial waters of Pakistan or are loading or discharging cargo or fuel within these waters; and
- (c) If any of the rules made in pursuance of this section is not complied with in relating to any ship, the owner or master of the ship shall be liable to a fine which may extend to three thousand rupees and the ship shall be deemed for the purpose of this part an unsafe ship.

Merchant Shipping Acts of 1894 and 1923 are totally outdated and has resulted in outdated Administrative procedures. Most nations (ex British colonies) who were following these Acts have repealed and replaced them with new ones. Pakistan should also adopt a new comprehensive Merchant Shipping Act to cope with modern demands. It is important that this Act should not be an Amendment Act but rather it should be a fully new comprehensive consolidated Act to replace the old Acts.

3.2.7. PROPOSED DRAFT BILL 1987.

As can be seen that these provisions are far too short to meet the present day requirements. Hence, the administration has drafted a proposed draft bill 1987. Art 412-417 of this bill deals with the carriage of dangerous goods.

Exporters (consignor) of dangerous goods should be required to accept the legal responsibility for the identification, classification, packing, marking, labelling, placarding and documentation of their

consignment. Because consignor is obviously the person who knows the nature of the goods and their potential hazards. Their responsibilities are usually laid down according to the mode of transport used in national and international regulations. This part is not covered in the proposed draft bill 1987. So, the following text is proposed to be added after article 417 as article 418 in the proposed draft bill 1987.

SPECIAL RULES ON DANGEROUS GOODS.

.1. The shipper must mark or label in a suitable manner dangerous goods as dangerous.

.2. Where the shipper hands over dangerous goods to the carrier or an actual carrier, as the case may be, the shipper must inform him of the dangerous character of the goods and, if necessary, of the precautions to be taken. If the shipper fails to do so and such carrier or actual carrier does not otherwise have knowledge of their dangerous character:

(a) the shipper is liable to the carrier and any actual carrier for the loss resulting from the shipment of such goods, and

(b) the goods may at any time be unloaded, destroyed or rendered innocuous, as the circumstances may require, without payment of compensation.

.3. The provisions of para 2 of this Article may not be invoked by any person, if during the carriage he has taken the goods in his charge with the knowledge of their dangerous character.

.4. If, in case where the provisions of para 2, sub-para. (b), of this Article do not apply or may not be invoked, dangerous goods become an actual danger to life or property, they may be unloaded, destroyed or rendered innocuous, as the circumstances may require, without payment of compensation except where there is an obligation to contribute in general average or where the carrier is liable in accordance with the provisions of article 5. Article 5 refers to Basis of Liability under Hamburg rules.

(Hardy, 1988)

3.3. Summary

Maritime transport like all other sectors of modern life is facing a whole variety of new revised regulatory complexities and quite simply, a lack of awareness of these would make an even an efficient maritime administration, port management and finest mariner ill prepared for the challenges of new law and changing marine policy.

A high level Ministerial conference on maritime safety held in Paris in 1982, resulted in the signing of the Memorandum of Understanding on Port State control by 14 European states. Under the memorandum the signatory states have agreed to carry out substantial inspections of vessels in each other's ports to check on all safety matters. Inspection rigor is escalated in accordance with deficiencies found. Particular attention is given to vessels carrying pollutant, dangerous, hazardous and noxious cargoes (Gold, 1989).

With these developments and reasons mentioned earlier, it is highly desirable that maritime administration must make comprehensive set of regulations or revise, update the existing regulations, not leaving any gaps or loop holes, so that these regulations could cater the modern aforesaid developments, match regulations of other developed nations and to keep pace with new technology.

It is worthwhile to mention that the extended base of maritime law has moved far beyond its traditional commercial base and today, includes a number of important aspects of the law of the sea, environmental law and law an policy for dangerous and hazardous cargoes.

Maritime education and training curricula in place in most states have not kept pace with this expansion. It is stressed that maritime education and training must today include a greatly increased portion of legal knowledge in order to ensure the overall complacency of those who operate vessels or manage ports in an even more complex maritime era. The subject of education and training is dealt with more in depth in the next chapter. However, it it is stressed here that with the development of laws and regulations, there should simultaneously be, education and training carried out at all levels to achieve highest safety standards and give practical meaning to the new regulations.

CHAPTER 4

EDUCATION AND TRAINING

4.1. INTRODUCTION

4.1.1. Before discussing anything about Education and Training, a common understanding of what is the basic difference between Education and Training is important. Besides a mere definition, which might be superfluous, the awareness of complexity of training is necessary to follow the arguments and proposals stated in this work.

Education is the basic knowledge about any subject imparted or given to an individual or group of people. For example, if you tell to some one that this type of cargo is dangerous and that there are certain risks attached to it which should be taken care off. Then this is an education about that cargo. Where as, "Training is the systematic development of attitudes, knowledge and skills required by an individual in order to perform adequately a given task or job." (Stammers and Patric, 1975). Taking the same above mentioned example of dangerous cargo, if you explain further that this type of cargo cannot be loaded with such and such cargoes and the type of packing, labelling, placarding, quantity, segregation and precautions to be taken then this can be said as training. However, most people will agree that a broader frame about training should be considered.

Fig 1: Allocation of Training to the safety and service.
Figure 1 shows the allocation of training to the

Fig. 1

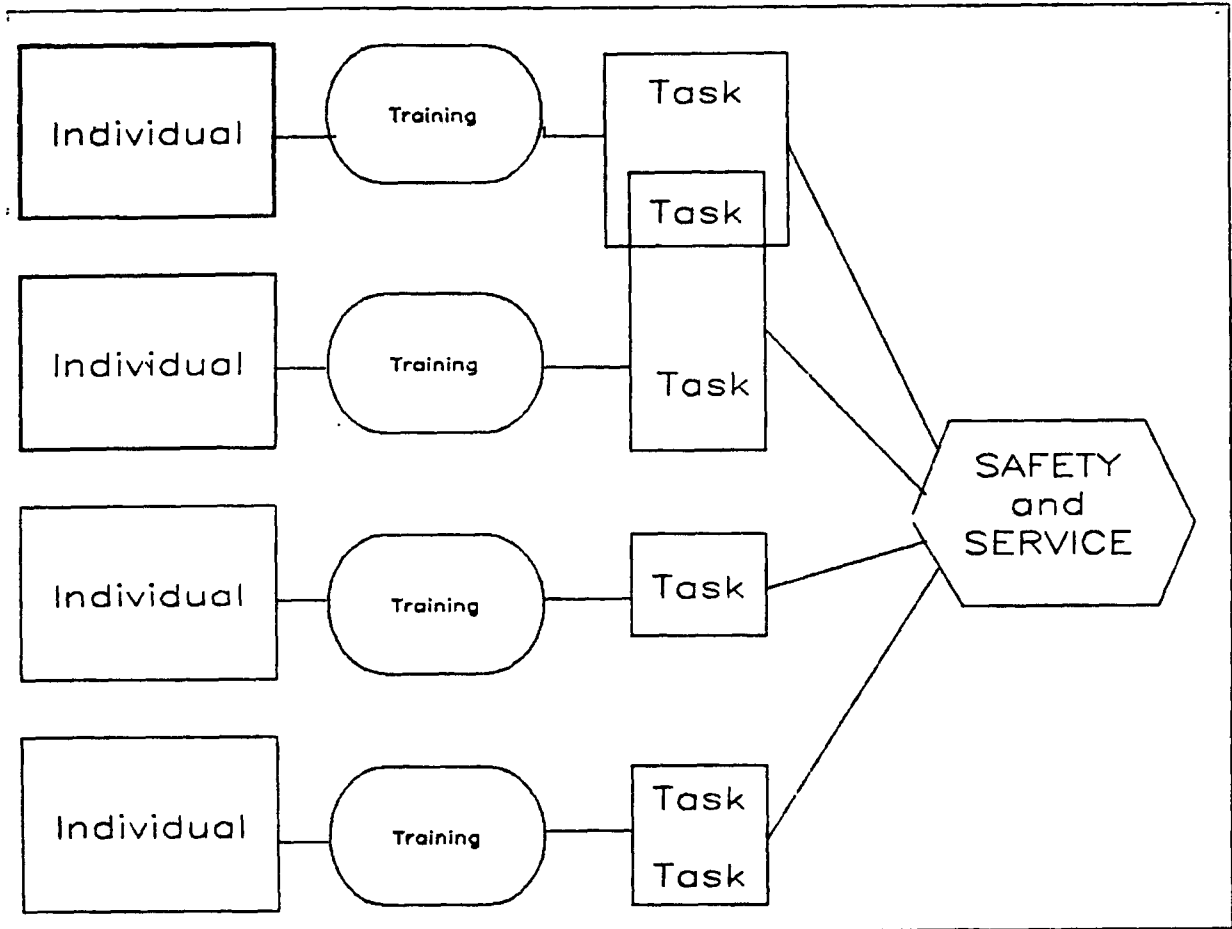

objectives according to the common understanding and it is evident that training should be governed by task requirements. But looking at the real training environment it can be seen that there are some other influencing factors, too.

Fig 2: Governing Parameters of Training

Besides the objective and task requirements exist such factors as:

- educational background;
- disposition and background of trainees
- costs;
- job benefits;

- future safety/job/task development;
- Resources;
- National Interest;
- National/International obligations;

- Existing training devices;
- Existing Organizational Structure;
- Instructors available; and
- Applied methods

and, according to specific circumstances many others. If and to what extent these factors could and should be considered in training design depends on an individual situation. Many thoughts are needed to design training but most come after central question has been answered "What requirements have to be fulfilled by an individual to cope with a defined job or task and which deficiencies have to be compensated by training efforts?" (Froese, 1989)

Fig 2

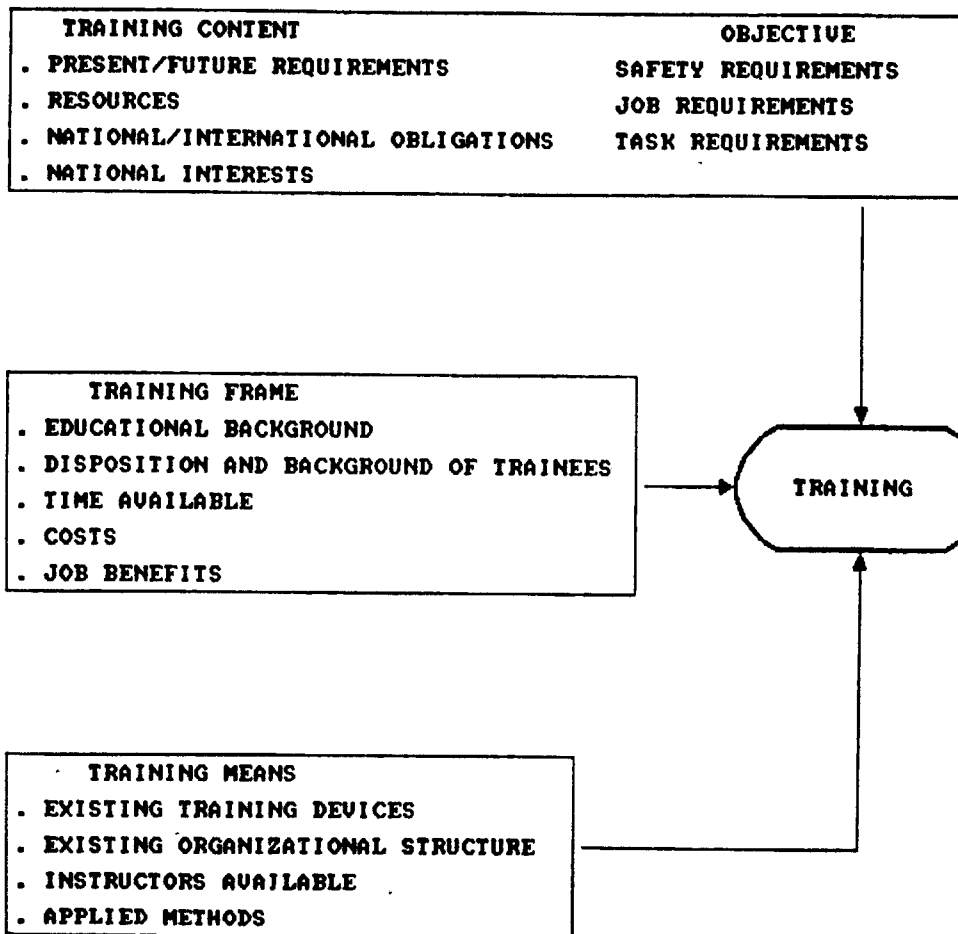

4.1.2. The education and training of port personnel and seafarers to meet the ever growing demands of a changing situation in the handling of dangerous goods whether it is a port or ship, which in its development continues to become more sophisticated is a challenge which must be faced by maritime nations whether developed or developing.

In developed Maritime States which are characterized by vast experience in the handling of dangerous goods have even felt the desirability of education and training in this particular specialized field. In Federal Republic of Germany, a law is in pipeline whereby a responsible person in a high position shall be assigned to deal with the training of dangerous goods in companies which are transporting more than 50 tons per year. It is expected that training schemes shall be implemented by law and people will be trained at special training centers for dangerous goods which are not in existence as yet. This necessity of training is being felt because of continuous modification and adjustments in the systems of handling of it's components in efforts to meet the changing demands occurring in this Sector of maritime industry. These changes not only affect the education and training procedures, curricula, training methodologies but also the human resource involved as may relate to the educational, academic and psychological capability of trainee to cope with the changing technologies and the ability of trainers to impart the required information effectively. This factor of human resource is the most crucial element of the whole training system.

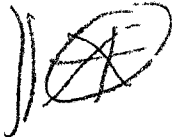

4.2. REASONS FOR EDUCATION AND TRAINING

4.2.1. INTERNATIONAL RECOMMENDATIONS ON TRAINING FOR PORT PERSONNEL

There are no standard recommendations by any international organization regarding training aspects on the transport, handling and storage of dangerous goods as yet. However, IMO is preparing a short course on dangerous goods in solid form in bulk and in packaged form for Shipboard personnel which could be used for port personnel also, which is expected to be published by the end of 1989 or in the beginning of next year.

The International Conference on Training and Certification of Seafarers, 1978 as per conference resolution 13 urged the then IMCO to study the matter for training and qualifications of officers and ratings of ships carrying dangerous and hazardous cargo other than in bulk. As a consequence of this request, IMO assembly adopted resolution A 537(13) on 17th November 1983. The annex 2 to this resolution contains recommendations on training of officers and ratings responsible for cargo handling on ships carrying dangerous and hazardous substances in packaged form and it provides an indirect provision for such a training to port personnel also. A training for port personnel could be developed by using these provisions as a basic structure.

The only specific reference of training for port personnel is mentioned in the IMO recommendations on safe transport, handling, and storage of dangerous substances in port areas, in Section 3.4.4 training. It states, "The Master of a ship and the berth operator within their respective areas of responsibility should ensure that personnel involved in the handling or storing of dangerous

substances are properly trained commensurate with their respective duties." However, this recommendation falls short of providing any detailed structure of provisions for training. So, detailed recommendations are required on international level to cover this type of training for port personnel.

4.2.2. SITUATION IN PORTS

There has been an exceptional evolution in maritime transport technologies, e.g. the containerization, ro-ro ships, lash barges and the specialization with many other types of ships, requiring special port handling facilities. These changes in transport technologies have forced the port managements to allocate the bulk of their investments in acquiring these technologies. As a logical consequence there was not much left to invest on safety matters. In brief, short term profit ability over rules safety in developing countries.

In the same era, there has been an enormous increase in the amount as well as in different types of dangerous cargoes which are handled in ports. As the variety and quantity of dangerous goods shipped in a port increases, so does the responsibility of the terminal and port authority. Their specialist knowledge of the handling and the risks inherent to those goods may not have grown likewise. This situation predominantly exists in the ports of developing countries.

Occasionally the extension of ports in developing countries has been haphazard and unplanned to meet the ad-hoc requirements which was beyond their control and mostly not in line with the original ideas by which the lay-out

not in line with the original ideas by which the lay-out of ports was planned. This situation further creates difficulties in the handling of dangerous goods.

In developing countries the education and training have not kept pace with these developments in the maritime industry as a whole and particularly in this specialized field of dangerous goods. Further due to lack of education on the types of dangerous goods and insufficient training in handling of such cargoes by the port personnel, the transport and handling of dangerous goods is not matched by the appropriate awareness.

All the above mentioned factors have contributed to the present situation and resulted in:

- Inadequate legal frameworks and administrative procedures;
- A lack of appropriate port facilities;
- Unsafe operational performances; and
- None availability of special training programmes.

4.2.3. INVESTIGATIONS OF ACCIDENTS

Interconnection between technological achievements and safety level should be considered with due account taken of the human factor. The human factor is the weakest link in the man - technique - environment system. Therefore an information support of the human link is a matter of great importance. The human factor manifests itself in what is called making a fetish of new techniques, that being sometimes the cause of fatal accidents. (Yakushenkov, 1988). Investigations of accidents involving dangerous cargoes show that 65% of accidents happen due to direct

knowledge, inadequate handling procedure or by lack of safety precautions. This factor of human error can never be fully eliminated no matter how good the training be, but can be largely reduced and minimized to an accepted standard with a margin in level of safety by proper education and training of port personnel and seafarers.

4.2.4. STATEMENTS OF OFFICIALS

In the light of the above mentioned problems the then Minister of State for Communications in Pakistan, Sardar Fateh Mohd Hasni in his inaugural speech on the occasion of Seminar on the transport of dangerous substances held at Karachi Port Trust Staff College, 18th to 22nd September, 1988 emphasized the need of training of port personnel and of port users. (See Annex VI).

On the same occasion, the Director General of Ports and Shipping, Rear Admiral Sajjad Akbar remarked that, "Training and education of handling dangerous goods by port personnel or port users can play a vital part in the safety, strategy and pattern of a break bulk port; basic training for members of the safety division, and all those who are regularly responsible for dealing with dangerous goods at administrative, operational and storage stage." He further stated, "Advanced training courses for those port employees who are directly and daily involved in the transport of dangerous goods cover subjects in more detail and with the objective of achieving a higher sense of awareness and responsibility in applying all necessary safe measures and the ability of using initiative of one's own whenever required." (IMO Mission Report, 1988)

In the closing address of the same Seminar Secretary of

Communications, Haq Nawaz Akhtar stated, "The fact that needs to be emphasized is that more than 90% accidents took place because of lack of knowledge and in-sufficient measures taken when landing the dangerous cargo at the time of its transportation either at ports or ships or by other modes of inland transportation. It is, therefore, essential that there should be a net work for training of port personnel, seafarers, managers and operators of transport sector in this field. (IMO Mission Report, 1988)

These statements by the policy makers show that there is an awareness and concern for the handling of dangerous cargoes in ports of Pakistan and it has been realized that there is a need for education and training of port personnel at all levels to meet the potential hazards of transport handling and storage of dangerous goods.



4.3. SITUATION IN PORTS

4.3.1. The present situation of safety in transport needs very definite improvements. The safety in the handling and storage of dangerous goods is a part of overall safety of the port, but this factor is perhaps the most crucial one. Any measures taken in the handling of dangerous goods would enhance the overall safety of port.

4.3.2. To achieve a comprehensive safety situation in the port two areas of personnel have to be trained:

- .1. The port personnel related to shore based industry; and
- .2. The Shipboard personnel or the seafarers.

The most effective way of improving the prevailing

conditions in the port is by raising the education/ knowledge level of personnel working in the port. This is not any easy task and the existing conditions shall not improve in short term specially not as regards to safety as for dangerous goods are concerned. Therefore, special training of various kinds is desirable to achieve positive definite results. Since the port personnel at all levels lack knowledge in this specialized field of dangerous goods, adequate training would require different courses for the different level of personnel. The contents of syllabi will also be different for different type of dangerous cargoes. This would create financial as well as organizational problems. Hence, reasonable means have to be found to achieve desirable objectives.

The training for the seafarers and port personnel shall be aimed as a minimum to meet the mandatory, minimum training requirements of IMO as specified in Regulation II/2, Appendix, paragraph 10 (c) and (d), of the International Convention on Standards of Training, Certification and Watchkeeping for Seafarers (STCW), 1978.

4.3.3. There exists different conditions in ports and terminals due to the handling of packaged dangerous goods and of bulk dangerous substances, i.e. liquified gases, liquid petroleum, products and petrochemicals which require different handling equipment and procedures because of their varying nature. This situation demands a bifurcation in training for the concerned personnel. However, in ports where both types of cargoes are handled, certain common subjects could be combined for different courses. In general, the following subjects will be covered depending on the level;

- .1. Safety risks and hazardous,
- .2. International/National Regulations and requirements,
- .3. Theoretical background,
- .4. Practical application,
- .5. Financial implications,
- .6. Contingency plans.

4.3.4. The level and type of training will depend on the educational background, nature of the job and responsibilities of the personnel from various sectors of industry to meet the appropriate aims and objectives. The trainees may be divided into four groups to make the training more practical:

- Top management;
- Middle management;
- Safety Personnel and junior management; and
- Dock workers/ other labour.

4.3.5. The entities involved are governmental, semi-governmental and private. The governmental and semi-governmental personnel include, personnel from port directorate, mercantile marine, dock labour board, custom, police, marine safety, coast guard, medical center and fire-brigade. The private personnel are from shipping companies, stevedores, forwarders, agents, etc. It would be prudent to organize joint training courses in a port for all port related personnel. This integrated training will promote better understanding and cooperation by giving an inside vision of others problem, thus enhancing the safety through better Communication within the port. Gunther Zade, Vice Rector and Academic Dean of WMU stated , " A short course on dangerous and hazardous cargo



," A short course on dangerous and hazardous cargo (other than in bulk) e.g. could be used to bring together all those concerned with the subject. Although their needs may partly differ but there is a common core knowledge on dangerous and hazardous cargo which is required by all those who are concerned with the handling and transport of such cargo.

A short course with an active participation of experts dealing with dangerous and hazardous goods on ship and shore will help further communication that can be expected to result in a better understanding of each others activities, mutual recognition, co-operation and, eventually, in an increase in safety and pollution prevention standards." (Zade, 1988)

4.3.6. In summary, the enhancement of safety in the handling of dangerous goods in the port will best be achieved by conducting training courses. Firstly, different courses are required in packaged dangerous goods and bulk dangerous substances. Secondly, four different types of integrated training courses, i.e. for all port related industries will cover the various hierarchical levels.

4.4. TYPE OF TRAINING

4.4.1. The training can be done in the form of short course, seminars, symposiums and workshops. However, type of forum depends on objectives, availability of resources, background and education level of trainees, availability of time, etc.

4.4.2. As stated earlier in para 2.1.1 that I.M.O. is

form in bulk or in packaged form for shipboard personnel which could be adopted for providing suitable training for port personnel also. The provisions of this course could formulate a basic structure. Then the knowledge of local conditions will be taken into considerations in order to design a suitable course.

4.4.3. Course Framework

.1. Scope

This course is intended for masters, officers and key ratings having special responsibilities for the receiving, handling, stowage or care on board ship of dangerous or hazardous cargoes in solid form in bulk or in packaged form.

The course incorporates and augments the mandatory minimum training requirements prescribed by Regulation II/2, Appendix, paragraphs 10(c) and (d), of the International Convention on Standards of Training, Certification and Watchkeeping for Seafarers (STCW), 1978.

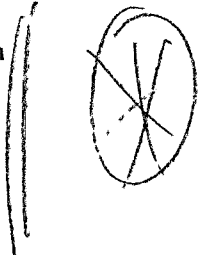

The course has been prepared in accordance with resolution A.537(13) on the Training of Officers and Ratings responsible for Cargo Handling on Ships Carrying Dangerous and Hazardous Substances in Solid Form in Bulk or in Packaged Form, adopted by the IMO Assembly on 17 November 1983 pursuant to resolution 13 adopted by the International Conference on Training and Certification of Seafarers, 1978.

Part 1 of the course covers the principles involved and Part 2 the application of such principles to ship

operations.

This course may be adapted to provide suitable training for all concerned with the handling or storage at terminals and in port areas of dangerous or hazardous cargoes. It may also be adapted to provide suitable training for personnel involved in the administrative aspects of multimodal transport operations. The adaptations recommended for these purposes are set forth in the Instructor Manual, Part D of the Course.

The training provided by this course should be supplemented by practical experience at sea or, where appropriate, in shore-based operations.

.2. Objectives

Ship's personnel successfully completing this course should thereby be enabled to understand the legal implications of and to correctly apply or verify compliance with:

- the mandatory requirements of part A of chapter VII of the International Convention for the Safety of Life at Sea, 1974 (1974 SOLAS Convention, as amended);
- the mandatory requirements of regulation II-2/54 of the 1974 SOLAS Convention, as amended, in respect of ships intended to carry dangerous goods;
- the mandatory requirements of annex III, as amended, of the International Convention for the Prevention of Pollution from Ships, 1973, as modified by its Protocol of 1978 (1973/78 MARPOL);

- the mandatory requirement that incidents involving harmful substances be reported pursuant to Protocol I to MARPOL 73/78, as amended, and the associated reporting procedures set forth in resolution A. ... (16) on General Principles for Ship Reporting Systems and Ship Reporting Requirements, Including Guidelines for Reporting Incidents Involving Dangerous Goods, Harmful Substances and Marine Pollutants, adopted by the IMO Assembly on .. October 1989;
- the detailed instructions on safe packing and stowage of dangerous goods including the precautions necessary in relation to other cargo as set out in the International Maritime Dangerous Goods (IMDG) Code, its Annex I on Packing Recommendations, the Emergency Procedures for Ships Carrying Dangerous Goods (EmS), and the Medical First Aid Guide for the Use in Accidents Involving Dangerous Goods (MFAG);
- the Recommendations on the Safe Use of Pesticides in Ships;
- the International Convention for Safe Containers, 1972 (CSC);
- the IMO/ILO Guidelines for Packing Cargo in Freight Containers or Vehicles;
- the Recommendations on the Safe Transport, Handling and Storage of Dangerous Substances in Port Areas; and
- Code of Safe Practice for Solid Bulk Cargoes (BC Code).

4.5. THE COMPOSITION OF TARGET GROUPS

4.5.1. A cost effective training has to be feasible and practical. The employees of port related industries with different hierarchy level may be combined for training purposes into four target groups with a further subdivision for packaged and bulk dangerous goods as stated earlier in para 3.4.

4.5.2. The top or senior management have very wide responsibilities. They cannot be expected to know all technical details, but require sufficient consciousness of the dangers and risks involved so that appropriate and adequate safety measures are introduced. Their policy decisions, financial, organizational and administrative procedures must have very sound basis. A theoretical training in the form of a short seminar to be repeated approximately every 4 years is suitable.

4.5.3. The Middle management, who make the day to day decisions of a practical nature which have a considerable learning on safety. These employees may work in operation, administrative and other areas and are marginally involved in the handling of dangerous cargoes, thus dangerous goods are only part of their responsibilities but of a very important nature. They need not be technical experts but intensive awareness course is essential. It is important that middle management keeps herself abreast of new developments and hence a repetition of course regular intervals approximately every three years is desirable.

4.5.4. The junior management and safety personnel whose sole responsibility are the dangerous cargoes and also

personnel from emergency services have to receive the most extensive training because they have to supervise the enforcement of safety. They have to have the technical expertise and they should have theoretical, practical and on job training. This training would be of longer duration but need not be repeated. The participants of this course should be encouraged to keep themselves upto date of all modern developments by giving them the chance to participate in national and international seminars, symposiums.

4.5.5. The largest group of port personnel requiring safety training in dangerous cargoes are the dock workers and stevedores. Truck drivers who also have no training in dangerous goods and are involved in transportation of dangerous goods in port areas should be encouraged to join along with dock workers to enhance safety. An example is quoted below but to highlight the point.

The following example of an incident with dangerous goods refer to a truck driver who in general have no training and probably it would not be difficult to find similar incidents, examples in port areas while handling such cargoes. In order to preclude such incidents in the future, a very basic awareness training would enable this group to handle dangerous goods safety, to behave properly in the vicinity of such cargoes and to take appropriate first action in case of an accident like a small spillage or an unusual smell, the detection of a damaged package etc. Their appropriate first action may present a major disaster. Their training should be repeated from time to time to remind them of safety.

Example: On a rainy day, some inadequately secured drums

of METHYL ISOCYANATE which is flammable liquid and irritant properties had fallen from a truck. The driver seeing the drums falling, stopped and attempted to recollect the drums, some of which had damaged and were leaking. He saw some kind of smoke and while recollecting he inhaled the toxic fumes, collapsed and fainted. To his good luck there were some people around who saw the incident and raised alarm. The emergency services rushed to the scene and saved him. Actually the smoke was highly toxic nitric fumes given off by violent reaction between the liquid and accumulated rain water. He knew at least vaguely, that the particular substance in his case was flammable but he had no idea of its toxicity, even though thorough documentation was included with the load.

4.6. TRAINING OPPORTUNITIES/FACILITIES

4.6.1. In developing countries, the training for port personnel at local port training centers is not available due to none availability of qualified and trained personnel. The Trainer project of UNCTAD is based on centrally developed training modules which concentrate on economy related topics which are locally adopted to the existing conditions and safe transport handling and storage of dangerous goods has not yet become part of their training activity. IMO from time to time does organizes short seminars in different regions on dangerous cargoes at the request of a developing country but they are too few. There are some free lance consultants available but commercial principle and considerations come in the way, additionally they have other priorities too. Training abroad is possible but it is very expensive and requires assistance in terms of fellowships/scholarships.

4.6.2. The lack of training facility at a reasonable cost is apparent in developing. More opportunities shall come through if port's top management press for such a demand. The assistance is possible from international organizations and man power development projects of industrialized countries. But such projects have to be initiated on government to government basis.

4.6.3. The most critical influences on new training schemes are the existing training means. Organizational structure, available staff, organization, methods and devices normally have a stronger impact on a new scheme than all thoroughly evaluated training contents. And if one fails to carry through what is needed at the very beginning of a new program, one will need many years to compensate for the shortcomings, if at all.

4.7. TRAINING IMPLEMENTATION

4.7.1. The training program has to be planned addressing the needs of all the four previously mentioned groups and to be based on major objectives, training period, principle approach, type of instructors, the venue, teaching methods, examinations, evaluation and incentives. For each group these questions shall be briefly dealt with as follows:

.1. Target group: Top and senior managers

Main objectives: Related to legal (port regulations), financial, administrative and organizational questions.

Duration: One to two days (could be part of a seminar covering other topics as well).

Principal approach: Symposium or seminar with lectures, question periods, panel discussion.

Lecturers or instructors: Lecturers with international experience and of repute.

Place and venue: National event with suitable location.

Teaching techniques: Lectures with selected audio-visual teaching aids, discussions.

Examination: None

Evaluation: Not suitable; if at all then verbal.

Incentives: None

.2. Target group: Middle management

Main objectives: Safety risks and principles, international requirements, national/local regulations and practice and their improvement, port relationship and cooperation.

Duration: Thirty to forty hours (one week).

Principle approach: Seminar or course with lectures, working groups, question periods, site tours.

Lecturers or instructors: Well experienced lecturers with a practical background.

Place and venue: Locally organized with suitable course

facilities.

Teaching techniques: Lectures with selected audio-visual teaching aids; informal atmosphere; working groups could be formed to deal with locally important questions; a practical approach should be aimed at and questions should be permitted at all times.

Examination: Not recommended; if though necessary as incentive and control, the multiple-choice tests should be used.

Evaluation: Written course/seminar evaluation on an anonymous basis.

Incentives: Certificate of attendance; tea and snacks provided.

.3. Target group: Managers with sole responsibility for dangerous cargoes, safety and emergency personnel.

Main objectives: Some theoretical and detailed practical knowledge of all related aspects; basic methodologies of imparting knowledge to others.

Duration: Depending on possibilities, but two weeks are the absolute minimum, better would be two months. 4-6 weeks.

Principle approach: Intensive course and study tour in with small groups covering theory and practice; on-the-job training.

Lecturers or instructors: Experienced and practical lecturers and instructors with appropriate professions,

including a chemist, a master mariner, a fireman, a port operations and safety expert, a port instructor.

Place and venue: Different localities; if possible, part of the training should be performed abroad; to expose on-the-job training at home.

Teaching techniques: Some lectures; working groups; role play; site visits; attachment to port safety departments in industrialized countries where exclusive amount of dangerous cargoes are handled; participation in specialized courses (e.g. fire fighting); individual approach.

Examination: Selected multiple-choice tests after certain parts of the training.

Evaluation: End-of-Training evaluation in writing.

Incentives: Certification; living allowance etc.

.4. Target group: Dockworkers and stevedores

Main objectives: Basic operational safety awareness;
immediate emergency actions.

Duration: About 25 hours

Principle approach: Practically orientated instructions,
based on working environment of trainees.

Lecturers or instructors: Port instructors of the training center or officer of safety services.

Place and venue: Locally organized; any suitable place within the port and near the working places of the trainees. (Dock Labour Training Center)

Teaching techniques: Simple instructional lessons and audio-visual aids; simple demonstrations; blackboard drawings; discussions.

Examination: Oral test.

Evaluation: None

Incentives: Certificate of attendance; paid-for tea and lunch; normal pay; course to be part of skilled worker status.

(Brunnings, 1988 b)

4.8. PROPOSED DANGEROUS GOODS COURSE

The designed course broadly outlines and is suitable for port personnel as well as sea-going officers. The course is an intensive one week course of 40 hours duration. The course is planned to cover all IMO requirements. However, this proposed course will be further improved after IMO publishes its course module on dangerous goods mentioned earlier in para 2.1.1.

4.8.1. COURSE AIMS

The main aim is to give the participants knowledge and descriptions of various aspects of dangerous goods in packaged form and to enable them to understand the properties and characteristics of dangerous cargoes, their potential hazards, classification, packing, labelling,

handling, storage, segregation and securing in break bulk as well as containerization form. They will also be educated about International and National regulations which regulate the handling of dangerous cargoes in port areas as well as at sea. The overall aim of the course is to enable those concerned with the transport of dangerous goods to have a better understanding of the hazards involved and the steps to be taken to control those hazards.

The objectives of the course are expressed as follows:

.1. Basic Chemistry

Leading to an understanding of the terms used in the IMDG Code and other transport documents, and an understanding of the hazards to ship cargo and personnel in relation to:-

Fire; explosion; corrosives and poisons.

.2. The Classes of Dangerous Goods and the Risk Associated

with Each Class

Leading to a knowledge of what hazardous goods are and how they are identified.

.3. Dangerous Goods Legislation

Leading to an awareness of the requirements under law and the correct shipping and receiving procedures to make the transport of hazardous goods safe, including the requirements for declaration, packaging, labelling

and segregation as per IMDG Code.

.4. The Shipboard Responsibilities

Leading to a positive shipboard attitude to the safe transport of hazardous goods and the establishment of correct procedures.

.5. How to Deal With Emergencies

Leading to the development of pre-planned procedures for dealing with fires and spillages and a knowledge of how to obtain further information or assistance from ashore.

4.8.2. COURSE STRUCTURE

Day 1:

- Introduction to course.
- Objectives.
- Definitions of Dangerous substance, Dangerous goods, pollutants,
- Types of Reactions.
Combination, replacement, double decomposition and thermal decomposition.
Oxidation and reduction.
Acids and bases.
Dilution and neutralization.
Exothermic and endothermic reactions.
- Organic Chemistry
Alkanes, alkenes and alkynes. Aromatics.
Hydrocarbons. Ideas of functional groups.
Systemic naming.

Polymerisation.

Physical changes, solid, liquid and gases. Cryogenics.

Combustion.

Flash point, ignition temperature and SIT. Spontaneous combustion.

- Explosions.

Propellants, detonators, high explosives. Meaning of terms such as "brisant".

Explosion of a closed container in a fire.

Radioactivity, what it is, harmful effects, measurement.

Poisons: form, methods of entering the body, physical and chemical action. Harmful or injurious substances, narcotic effects.

Day 2:

- The classification of hazardous goods.
- The IMO classification and the hazards associated with each class.
- Materials hazardous only when in bulk.
- Conventions, regulations and recommendations. STCW 1978 requirements.
- Dangerous Goods legislation in Pakistan..

Day 3:

- Familiarization with the IMDG Code
- Declaration, documentation, packing, labelling and placarding.
- Freight container and vehicle packing, portable tanks, tank containers and road tank vehicles and units for transporting dangerous goods.
- Multimodal transport aspects.
- The philosophy of separation segregation and quantity

limits.

- Packing standards.
- Dangerous goods in port areas.
- Shipboard responsibilities

Day 4:

- General requirements for stowage on various classes of vessel.
- General cargo, Ro-Ro, container, lash, seebee and combination carrier.
- Specific handling, stowage and segregation requirements for each class of dangerous goods.
- Syndicate exercise in the acceptance and stowage of dangerous goods.
- Pollution by dangerous cargoes. Introduction of computer usage for Dangerous goods.

Day 5:

- Emergency procedures.
Action to be taken in the event of fire, leakage and spillage.
- Personnel protection.
Breathing apparatus, protective clothing, measuring instruments, use and interpretation of results.
Precaution to be taken for entry into enclosed spaces which may have an oxygen deficient, toxic, harmful or flammable atmosphere. Pre-planning emergency action in port and at sea.
- IMO Emergency procedures for ships carrying dangerous goods.
- IMO medical first aid guide for use in accidents involving dangerous goods, cross references.

- Case histories.
- Other sources of information and information and assistance from ashore. Practical incident drills and decontamination procedures.
- Course evaluation.

4.9. TRAINING AND INSTRUCTORS

4.9.1. Training is an expensive affair with no immediate returns. However, benefits of training will be felt in the long run. It is unfortunate that in developing countries, whenever budgetary strains are felt, the first thing which is axed is training. The managements do not realize that by doing so, they put their own development plans in reverse direction.

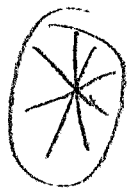

4.9.2. The dangerous goods subject is one of the technically most difficult subjects of port training curricular. It is not possible for a normal instructor to teach all subjects of dangerous cargoes with all technical details unless he has special training. A practical approach would be that special trained staff of safety services take part in the course and takes over the more technical parts, where as the less technical parts should be handled by normal instructors. It is suggested that there should be a full-time instructor for only dangerous cargoes who is trained abroad.

CHAPTER 5

CONCLUSIONS AND RECOMMENDATIONS

5.1. The most important single element contributing to safe handling and transport of dangerous goods is a good organization and good management. The good management is one that will appreciate the risks, ensure compliance with the laws, international recommendations and good operating procedures, and will ensure that the business is furthered by a well trained and competent staff in all cadres.

For reorganization and improvement of safety in port, it is necessary to assess the present situation, identify the needs, propose improvements in existing practices and procedures and other areas where deficiencies are observed.

5.2. With the rapid expansion of trade and transport of dangerous goods, the importance of having internationally accepted regulations or standards and guidelines for their transport, handling, storage and stowage, etc. becomes obvious.

Whereas for maritime transport the requirements in SOLAS convention and the provisions of the IMDG Code, with its Annexes and Supplements were initially very much directed for sea mode of transport, the majority of these provisions are apposite also to dangerous goods in port areas, particularly those concerning safety aspects, e.g. storage, segregation, safe handling, emergency response procedures, first aid and medical treatment.

By adoption of IMDG Code the Maritime Administration has partially fulfilled its obligations under Chapter VII Part-A of SOLAS 1974 Convention. However, unless effective implementation of the code is achieved her obligations are still not fully fulfilled. The competent authority designated by Maritime Administration must clearly interpret the vague terms such as "sufficient", and "adequate", and where references to competent authorities are referred to in the IMDG Code. Such clarification can be done by publishing a supplement which must be read in conjunction with IMDG Code and should be effected by statutory regulatory order through Gazetted notification.

The IMDG Code is related to safety at present but its application has been extended to marine pollutants with the adoption of 25th amendment which will come into force from January 1, 1991. The Maritime Administration must prepare itself to accept further legal obligations.

It has been identified that there is a need for setting up a standing advisory committee of experts from various agencies/ departments concerned with dangerous substances on the national level, who shall base their decisions on scientifically achieved results and also take decisions where conflict arises. Such a committee is recommended internationally as one of the most effective tools of management to assist in the handling of dangerous goods. The competent authority shall take guidance for implementation of effective measures from their decisions. No single Administration could have all the expertise needed on the staff. As such this group fills the gap. This is in practice in most of the developed countries.

5.3. Export of cotton is one of the main sources of earning foreign exchange needed badly for the development the of economy of the country. As such, incidents of fire losses should be minimized. It has been identified that the storage facilities of cotton at T.P.X. area are poor. It is strongly recommended that the K.P.T. management should draw up re-development plans of T.P.X. and should incorporate it in their next development plan. Aid for such development can be sought from international agencies, i.e. World Bank, UNDP, etc through Ministry of Communication and Ministry of Planning. The development of T.P.X. shall greatly enhance safety against fire, increase efficiency and also help in preventing quality deterioration of cotton.

5.4. The siting of berths where dangerous goods are handled determines virtually all subsequent actions to be taken in port operations in order to achieve the desired level of safety.

For existing harbours like Karachi Port where dangerous goods are to be handled together with other goods the site is prefixed. Here recommended safety distances cannot be met by distance alone. The lack of space and the ensuing lower level of safety has to be compensated for through:

- .1. Constructional features: e.g. in shed buildings, temporary storage area, etc; (see Annex III) and
- .2. Operational procedures: e.g. handling regulations, special watchkeeping by fire brigade, maximum allowable quantity at specific berths and in port area, etc. (see Annex II)

It has been identified that the D.G. Shed which serves as a temporary storage area is totally inadequate for space and is unsuitably located.

Until, another suitable location with adequate space is found for the D.G. Shed, the following measures are proposed:

- The baggage shed in the adjoining area should be spared for dangerous goods to overcome for space requirements;
- Solid concrete walls should be erected from boundary wall of D.G. Shed to the pier to prevent it from being used as a public thoroughfare;
- Inside the dangerous goods storage zone separation and division according to IMDG-Classes should be strictly observed. Annex IV shows the recommended IMDG Code regulations translated for port areas. This could be used for practical application;
- Separate sewer system for each IMDG-Class; and
- Containers storage area should be sufficient to allow for storage on ground level of all containers containing dangerous goods, i.e. (no stacking).

5.4.1. It is against the norms of an efficient port not, to accept damaged packages of dangerous goods from ships. Hence, a damaged goods section should be provided where all dangerous goods arriving at the terminal in abnormal condition (fuming, burning, leaking, heated, etc) may safely be placed awaiting:

- Chemical experts intervention;
- Fire fighting brigade; or
- Total perishment of goods.

Adequate protection of other installations (earth bunds), separate sewer system, water washing installation for clean-up of the area, supervision, fire fighting equipment should be provided.

5.4.2. The Operations Division of the Karachi Port has categorized the dangerous cargoes into four groups:

- .1. A very high risk cargo namely explosive;
- .2. High risk cargoes of gases and inflammable liquids
IMDG-Class 2 and 3;
- .3. Low risk cargo, i.e. IMDG-Class 4, 5, 6, 8 and 9;
and
- .4. Radio active material IMDG-Class 7.

It has been identified that this categorization is wrong. It shows lack of awareness, and it appears that the philosophy and principle behind the classification of dangerous goods is not understood.

The various Classes in the IMDG Code are not in relation with the degree of danger, but only with the type of danger involved. There are extremely dangerous substances in all classes and the danger is indicated either by sub-classes (in Class 1) or by packaging groups:

- I High hazard
- II Medium hazard
- III Low hazard

As an example, explosive substances and articles of Class 1, division 1.4 are certainly less dangerous than many other substances in other classes.

It is strongly recommended that this categorization of groups must be immediately cancelled through an administrative circular and all concerned in the shipping industry are notified.

ALTERNATIVE PROPOSAL

It is highly desirable that any system of classification adopted follows closely the system recommended by the United Nations Committee of Experts on the transport of Dangerous Goods and which is widely applied throughout the world.

The UN Recommendations, the IMDG Code and the Air Transport Regulations place substances and articles of most classes into packaging groups I, II and III according to the degree of danger they present. The new RID/ADR Regulations use the letters (a), (b), or (c) in a similar way.

Packing group I	-letter (a)	RID /ADR	-highly dangerous (x)
II	-	(b)	-dangerous (y)
III	-	(c)	-minor danger (z)

The principle of dividing dangerous goods into the above mentioned three packaging groups does not cover classes 1, 2, 6.2 and 7.

The degree of danger for explosives are according to the sub-class. However, special requirements for the above mentioned 4 classes are given in detail in the IMDG Code and reference should be made to individual schedules for their placement into a class.

The diverse properties and characteristics of the substances and articles covered by class 9 also do not permit a form of packing which would be generally applicable. So, no grouping criteria have been developed for this class. The packaging group of a substance or article has, therefore, been assigned on the basis of assimilation with goods having similar properties and character. Individual requirements are given for each substance or article in its individual schedule.

The dangerous goods may still be divided into four groups, however the principle of categorization would be entirely different. In addition to the actual dangers of the good, acceptance conditions may also have to take quantities into account. Particularly, the amount of certain explosives and other highly Dangerous Goods in a port at any one time should be limited. Annex II shows the method by which the port of Hamburg is dealing with this problem.

(Brunings, 1988)

Group 1: Radio active substances, certain explosives and some goods of packaging group 1, loading/ discharging at a remote berth or mooring and would be subject to direct delivery.

Group 2: Other dangerous goods of high or medium danger, would be permitted to be handled at an ordinary pier but would be subject to direct delivery. Again, some explosives, radio active materials and some goods of packaging group 1 and 11 may fall into this category.

Group 3: Dangerous goods of packaging group 11. These

goods may be allowed for storage in the port area for a limited period only. For their segregation see Annex IV.

Group 4: Dangerous goods of packaging group 111. These may be allowed for storage in the port area for a limited period.

5.4.3. As far as dangerous goods are concerned it appears that short term profitability rules over safety and pollution, financial resources and the attention of management is focussed on investments which effect productivity increase. The long term effects of safety investments on a positive productivity development are not or do not appear to be appreciated. This situation becomes more clear when it is identified that the Planning Department of K.P.T. has not made any provisions for a suitable dangerous cargo jetty with an appropriate warehouse in her 5th development project which is known as Western Backwater Complex.

It is recommended that immediate steps should be taken to incorporate provisions for a suitable dangerous cargo jetty and a warehouse in the current development plan. This measure will enhance greatly the overall safety of port and environment. (for guidance see Annex III)

The port planners are reminded that accident statistics show that the overwhelming majority of accidents in and around ports are caused by human error or failure. Therefore, if a well conceived port design is not complemented by a port work organization that is safety conscious - and information is vital to this - no safe port operation can be obtained.

5.5. The movement of dangerous substances both by land and sea should be a careful, safe, smooth and a well monitored operation. Legislation for dangerous substances is meant to provide the legal framework to carry out this activity. If the legislation/ regulations are outdated then they cannot serve the purpose. In Pakistan, dangerous substances are covered under six different pieces of legislation. It has been identified that some of these legislation are totally outdated, i.e. Explosive Act 1884, Merchant Shipping Act 1894, etc. Furthermore, most of the regulations made under these Acts are obsolete as well. This has caused and resulted in inadequate legal frameworks and administrative procedures.

As shipping is an international activity, it is equally of international interest that port regimes are similar wherever possible. Rules and regulations should thus show an easily recognizable resemblance. Special requirements due to local circumstances however cannot be avoided but the risks should be perceived that such special requirements in ports may lead to unsafe operating conditions.

It is recommended that the Maritime Administration should propose new legislation and must formulate either new or revise/update the existing regulations to provide a sound infrastructure to cope with the modern developments and present day demands and match regulations of other developed nations. Guidance may be sought from UN, IMO publications and maritime legislation for dangerous substances of developed countries. As for example, United Kingdom which has published and enforced national Regulations for Dangerous Substances in Harbour Areas with

the Associated Guides and Code of Practices may be followed.

Explosives require special consideration because of their hazardous nature. They have to be considered in the context of compatibility group and hazard division. Quantity/distance tables have been established which take into account such parameters as shock waves by blast, propagation of an explosion, heat radiation, etc. They range from 48 meters to 4200 meters. This of course depends on quantity of explosives and protection required. (see Annex I)

The carriage, handling, and stowage of dangerous substances on board ships is governed by Merchant Shipping Act 1894. As stated earlier this Act is outdated and most nations which were following this Act have repealed and replaced it with new ones. Now, the Maritime Administration in Pakistan has also proposed a new Merchant Shipping Bill, which when approved shall replace the old Act.

5.5.1. The Port should also formulate its own new port regulations and should specify operational procedures. Transport of dangerous goods is regulated in order to prevent, as far as possible, accidents to person or property, means of transport and now also for marine pollution. At the same time, regulations are framed so as not to impede the movement of such cargoes, other than those which are too dangerous to be accepted for transport. With this exception, the aim of the regulations are to make transport feasible by eliminating risks or reducing them to a minimum. It is a matter therefore of

safety no less than one of facilitating transport. New regulations should also take care of multi-modal transport aspect which is bound to be the ultimate future.

Regulations should subdivide dangerous goods as to direct delivery, special berths, quantity limitations on berths and in port, allocation of storage areas, documentary and administrative requirements, operational procedures and other criteria. New port regulations for dangerous substances need to be discussed with all port users and port related bodies as it shall affect them directly.

It is recommended that ports should establish a safety cell, which should monitor, supervise and enforce regulations. Such departments/cells are practically in existence in all major ports. The power of the law ensures that offenders are prosecuted and would be offenders warned and hopefully deterred. It is not important how much regulations are formulated but how effective those regulations are.

5.6. Dangerous goods are unique within the flow of goods. The handling has to be then from a two pronged approach, logistics and safety. This calls for good documentation procedures from the point of initial handling to the point of departure and the necessary action in between to cope with spillage, containment, treatment of casualties and ultimate destruction/disposal of cargo. This ensures:

- A reasonable safety level; and
- Minimum delay and least cost in handling.

A port authority must have precise and quickly accessible information on how a certain substance should be handled.

The handling of dangerous goods, therefore, is first a matter of information processing and secondly a matter of physical handling.

For information processing, the port has already a traditional manual office system. This role in future has to be taken over by computers. The computers are already in use for dangerous goods in dangerous goods sections of shipping companies, port dangerous goods terminals, port control centers in the developed ports of western nations. (e.g. Hamburg, Bremen, Rotterdam, Gothenburg, etc)

The highest possibility for an accident exists during handling activities. In this regard proper equipment to do the job is very important. For example: the use of pallets in combination with a net for polycans or drums, the use of "drum hooks" in case of loose drums. It is evident that the use of proper equipment, responsible handling and trained men will not only reduce the chances of an accident but also the amount of damage in case of an incident and consequently their effect.

5.7. Due to revolutionary developments in transport technologies and enormous increase in number of chemical substances transported at sea, the subject of safety and pollution has become a global concern.

The storage and distribution function of a port has gained significant importance as it is an interface between sea transport and land transport. It is empirically stated that the risks involved in shipping of dangerous goods and the associated hazards are maximum within the port itself, where loading/discharging takes place or at the location of storage facilities. Risks and safety are inter-related.

By increasing safety measures risks are reduced. One of the important components of achieving safety is education and training.

It has been identified that the education and training of port personnel and seafarers has not kept pace with the developments in the field of dangerous substances. As such, the transport and handling is not matched by the appropriate awareness.

It has been identified also that the investigation of accidents involving dangerous goods show that 65% of accidents happen due to direct human error. The human error may be by lack of knowledge, inadequate handling procedure or by lack of safety precautions.

In view of the above, and for reasons mentioned in earlier chapters, it is obvious that the present situation of safety in port requires definite improvements.

The enhancement in safety can best be achieved by conducting training courses. It is recommended to conduct two types of separate courses, for packaged dangerous goods and bulk dangerous substances (some common subjects may be combined). Secondly, a "generic group of trainees" divided into 4 groups with different hierarchical levels may be the best way to satisfy the appropriate aims and objectives.

5.7.1. IMO is preparing a short course on dangerous goods in packaged form for shipboard personnel which could also be used for port personnel. I have also proposed a dangerous goods course in chapter 4. It is proposed that either of the courses or a mixture of both could provide a

basic structure and then the course could be further developed to satisfy the appropriate aims and objectives with different levels of trainees.

The training for the seafarers and port personnel shall be aimed as a minimum to meet the mandatory, minimum training requirements of IMO as specified in Regulation II/ 2, Appendix, paragraph 10(c) and (d), of the International Convention on Standards of Training, Certification and Watchkeeping for seafarers (STCW), 1978.

IMO assembly resolution A 537 (13), Annex 2 contains recommendation on training of officers and ratings on ships carrying dangerous and hazardous substances in packaged form. It is recommended that the course mentioned above on dangerous goods should be made a mandatory requirement as a part of Class 3 Certificate of Competency (Nautical) for seafarers. This will greatly enhance the capability of ship officers to deal with any emergency onboard ships at sea where conditions are much more severe.

5.7.2. The ship's officers usually have experience in handling of dangerous goods. Occasionally they have proper training too in dangerous goods. This human resource with experience and at times with training, is available on the market. The ports and shipping companies in the developed ports take advantage of this available resource and employ them in their operations department and especially in dangerous goods cell. It is highly recommended that the ports in Pakistan should also take advantage of their experience by employing them in their operation/traffic department.

5.8. That there has been no very serious accident since 1977 stemming from dangerous goods handling in port is indeed fortunate. However, it is necessary to look at the "what if" situation and of course the resulting "then what" procedures.

Although the K.P.T has a very efficient fire fighting unit, which is commendable, in case of a major crisis, outside support from other bodies will be required for which there should be, in writing, a pre planned contingency plan. However, no such plan exists at present.

It has been identified that there is no routine for providing information to the port fire services about the quantity and type of dangerous substances in the port. Availability of such a routine would provide a first minute information which in case of an emergency, would allow prompt knowledge of the type of fire to be fought. Since advance information is vital, it is recommended that such information should be provided to them.

It is also recommended that the port establishes an emergency coordinating centre, which has all the data of dangerous substances in the port and all necessary, relevant publications, etc. The port must set up a contingency plan in cooperation with other bodies like the police, coast guard, armed forces. local hospitals, chemical laboratory, municipal corporation, etc. All action which is to be followed must be laid down in writing. It should organize simulation exercises and educate personnel to meet any eventuality.

5.9. Finally, the port management is reminded that its most important task is to implant a high degree of safety

consciousness into its organization. The management has to show concern for safety, otherwise, men handling dangerous goods in the port cannot be expected to do so either. By providing training and a suitable working environment, the people will be motivated to do their utmost. This will achieve not only safety, but efficiency as well -something that should always be remembered.

LIST OF REFERENCES

1. Akbar, Sajjad: Annex 3, IMO Mission Report, Regional Seminar on Transport, Handling, Storage of Dangerous and Harmful Substances at Sea and in Port Areas and their onward transfer by other modes of transport, Pakistan, September 1988; pages 1-2.
2. Akhtar Haq Nawaz: Annex 11, IMO Mission Report, Regional Seminar on Transport, Handling, and Storage of Dangerous and Harmful Substances at Sea and in Port Areas and their onward transfer by other modes of transport, Pakistan, September 1988; page 2.
3. Anonymous, "The Safe Transport of Dangerous, Hazardous or Harmful Cargoes by Sea", Focus on IMO, publisher IMO, May 1988; page 4.
4. Anonymous, "The Safe Transport of dangerous, Hazardous, or Harmful Cargoes by Sea", Focus on IMO, publisher IMO, August 1989; page 8.
5. Anonymous, "Making way for pollutants", Hazardous Cargo Bulletin, Vol 10 NO 9, September 1989; pages 7-9.
6. Baundry, Karim: Annex 7, IMO Mission Report, Regional Seminar on Transport, Handling and Storage of Dangerous and Harmful Substances at Sea and in Port Areas and their onward transfer by other modes of transport, Pakistan, September 1988; pages 1-6.

7. Brunings, Karsten: "Personnel training in the transport of dangerous goods in port of developing countries", paper 7.2, Seminar on Dangerous Goods, Sweden, WMU, September 1988; pages 1-2 (a), 6-15 (b).
8. Brunings, Karsten: "The Safe Transport, Handling and Storage of Dangerous Goods in Ports", paper 12.1, Seminar on Dangerous Goods, Sweden, WMU, September 1988; pages 9-12
9. Economic and Social Commission for Asia and Pacific, Guidelines for Maritime Legislation, 1984?, pages 1-7.
10. Fazellani, R.J: Karachi Port Trust Manual for the Traffic Department, published by Karachi Port Trust, July 1985; pages 155-156 (a), 134-141 (b)
11. Froese, Jens: "Training for Advanced Ships", Maritime Training Forum' 89, Amsterdam, June 1989; pages 11-12.
12. Gold, Edgar: "International maritime law in transition, New challenges for education and training", Fifth International Conference on Maritime Education and Training, Sydney, Nova Scotia, Canada, September 1988; page 15.
13. Henry, Cleopatra Elmira: The Carriage of Dangerous Goods by Sea, The Role of International Organization in International Legislation, Graduate Institute of International Studies, Geneva, 1985; page 95.
14. IMO Publication: Safe Transport, Handling and Storage of Dangerous Substances in Port Areas, 1983; pages 20, 34.

15. Ivamy, E.R. Hardy: Encyclopedia of Shipping Law Sources (U.K), Lloyd's of London Press, 1988; Art 13 (c-26) page 402.
16. Letter from Traffic Manager to General Manager (P and D) of Karachi Port Trust, reference No T/C-6(1)33/1390 dated 12.2.81.
17. Manager of Publications, Government of Pakistan: The Pakistan Code, Volume XII, 1967; pages 22-26.
18. Stammers and Patrick, The Psychology of Training, in Jens Froese, Training for Advanced ships, Maritime Forum' 89, June 1989; page 1.
19. The Karachi Port Trust Manual, Part IV, August 1981; pages 52-56.
20. Wardelmann, Hubert E.H.S: "The Transport of Dangerous Substances by Sea", paper 3.1, Seminar on Dangerous Goods, Sweden, WMU, September 1988; page 6.
21. Wardelmann, Hubert E.H.S: "Classification, Grouping and Packing of Dangerous, Hazardous and Harmful Cargoes", Seminar on Dangerous Goods, Sweden, WMU, September 1989; page 22.
22. Yakushenkov, A: "The Role of Technology in the Development of Maritime Safety", Fifth International Conference on Maritime Education and Training, Sydney, Nova Scotia, Canada, September 1988; page 12.
23. Zade, Gunther: "Short Courses, Their Role in Maritime Education and Training, Their Implementation and

Evaluation", Seminar for Senior Personnel of WMU
Branches, Sweden, WMU, October 1988; page 15.

Description of substance or article to be classified	Compatibility Group	Classification Code
Primary explosive substance	A	1.1A
Article containing a primary explosive substance and not containing two or more effective protective features	B	1.1B 1.2B 1.4B
Propellant explosive substance or other deflagrating explosive substance or article containing such explosive substance	C	1.1C 1.2C 1.3C 1.4C
Secondary detonating explosive substance or black powder or article containing a secondary detonating explosive substance, in each case without means of initiation and without a propelling charge, or article containing a primary explosive substance and containing two or more effective protective features	D	1.1D 1.2D 1.4D 1.5D
Article containing a secondary detonating explosive substance, without means of initiation, with a propelling charge (other than one containing a flammable or hypergolic liquid)	E	1.1E 1.2E 1.4E
Article containing a secondary detonating explosive substance with its own means of initiation, with a propelling charge (other than one containing a flammable or hypergolic liquid) or without a propelling charge	F	1.1F 1.2F 1.3F 1.4F
Pyrotechnic substance, or article containing a pyrotechnic substance, or article containing both an explosive substance and an illuminating, incendiary, lachrymatory or smoke-producing substance (other than a water-activated article or one containing white phosphorus, phosphide or a flammable liquid or gel)	G	1.1G 1.2G 1.3G 1.4G
Article containing both an explosive substance and white phosphorus	H	1.2H 1.3H
Article containing both an explosive substance and a flammable liquid or gel	J	1.1J 1.2J 1.3J
Article containing both an explosive substance and a toxic chemical agent	K	1.2K 1.3K
Explosive substance or article containing an explosive substance and presenting a special risk needing isolation of each type	L	1.1L 1.2L 1.3L
Substance or article so packed or designed that any hazardous effects arising from accidental functioning are confined within the package unless the package has been degraded by fire, in which case all blast or projection effects are limited to the extent that they do not significantly hinder or prohibit fire fighting or other emergency response efforts in the immediate vicinity of the package	S	1.4S

TABLE 4.2 SCHEME OF CLASSIFICATION OF EXPLOSIVES, COMBINATION OF HAZARD DIVISION WITH COMPATIBILITY GROUP

Hazard Division	Compatibility group												A-S
	A	B	C	D	E	F	G	H	J	K	L	S	Σ
1.1	1.1A	1.1B	1.1C	1.1D	1.1E	1.1F	1.1G		1.1J		1.1L		9
1.2		1.2B	1.2C	1.2D	1.2E	1.2F	1.2G	1.2H	1.2J	1.2K	1.2L		10
1.3			1.3C			1.3F	1.3G	1.3H	1.3J	1.3K	1.3L		7
1.4		1.4B	1.4C	1.4D	1.4E	1.4F	1.4G					1.4S	7
1.5				1.5D									1
1.1-1.5 Σ	1	3	4	4	3	4	4	2	3	2	3	1	34

3. Quantity-Distances

Quantity-Distances to be observed by vessels when carrying, loading or unloading explosives at piers, jetties, wharves or anchorages are given in Table I-IV and are to be applied as detailed below for the Net Explosives Quantity concerned to ensure adequate protection of the Exposed Site (ES) :

- a) Measurements are made from the nearest point of compartments in which explosives are stored to the nearest point of the Exposed Site.
- b) Due allowance is to be made for the movement of ships due to tides when anchored or berthed at the single buoy. The radius of the swinging circle is to be taken into account in the overall distance, and the position of the aftermost compartment containing explosives taken as the point from which the quantity-distances should be measured.
- c) If it is necessary to berth two or more vessels containing explosives at less than the appropriate separation distances the total Net Explosives Quantity of all the cargoes is to be used to determine quantity-distances to other Exposed Sites. If berthing of two vessels together is unavoidable, they should be moored in tandem as the bows and sterns will afford additional protection and the exposed areas will be correspondingly reduced. Such vessels should be secured by the bows and sterns to prevent swinging. If explosives are stowed in fore or aft holds only, this should be taken into consideration when berthing ships in tandem to achieve maximum separation distances.

TABLE I

QUANTITY-DISTANCE TABLE FOR VESSELS HAZARD DIVISION 1.1, 1.2 and 1.3									
Net Explosives Quantity Q kg	Quantity-Distances m								
	D1	D2	D3	D4	D5	D6	D7	D8	D9
1.000	60	48	135	180	335	185	270	60	65
2.000		61			420	210	270		80
5.000		83	140	255	570	245	320	70	110
10.000	69	105	175	320	720	280	360	90	140
20.000	87	135	218	405	905	320	410	120	174
50.000	120	180	295	550	1230	375	480	160	240
100.000	150	225	375	690	1550	410	560	200	300
200.000	190	285	470	870	1950			250	375
500.000	255	380	640	1175	2645			340	505
1.000.000	320	480	800	1480	3330			430	640
2.000.000	405	605	1010	1865	4200			540	805
	$D = 3,2 \cdot Q^{1/3}$	$D = 4,8 \cdot Q^{1/3}$	$D = 8 \cdot Q^{1/3}$	$D = 14,8 \cdot Q^{1/3}$	$D = 33,3 \cdot Q^{1/3}$	$D = 53 \cdot Q^{0,18}$	$D = 68 \cdot Q^{0,18}$	$D = 4,3 \cdot Q^{1/3}$	$D = 6,4 \cdot Q^{1/3}$

TABLE II

SUMMARY OF QUANTITY-DISTANCES TO BE OBSERVED FOR SEAGOING VESSELS LOADED WITH OR LOADING OR UNLOADING EXPLOSIVES					
HAZARD DIVISION 1.1					
Exposed site	Potential explosion site	Vessels loaded with explosives		Vessels loading or unloading explosives	
		barri-caded	unbarri-caded	barri-caded	unbarri-caded
Vessels loaded with explosives		D2	D2	D3	D3 (135m min)
Vessel loading or unloading explosives		D3	D3	^a D3	^a D3
Inhabited buildings (f)		bce D5	bce D5	bce D5	bce D5
Public traffic routes and main shipping routes		D4	D4	D4	D4
POL jetties		^d D4	^d D4	^d D4	^d D4

NOTES :

- a) Ships moored in tandem may use D2-distances.
- b) Double D5-distances should be used for hospitals, schools and large office blocks of vulnerable construction.
- c) D4-distances may be used for isolated dwellings.
- d) A minimum distance of 450 m to be observed from aboveground POL storage tanks.
- e) A minimum distance of 400 m should be used to built-up areas.
- f) Administrative buildings within the port area should be located at "Inhabited Building"-distance.
- g) D3-distances may be used for holding areas.
- h) If the ammunition to be handled is classified as Hazard Division 1.1 and is of the fragmenting type, the quantity-distance should be taken from both table II and table III and the greater of these should be used.

TABLE III

SUMMARY OF QUANTITY-DISTANCES TO BE OBSERVED FOR SEAGOING VESSELS LOADED WITH OR LOADING OR UNLOADING EXPLOSIVES

HAZARD DIVISION 1.2

Exposed site	Potential explosion site	Vessels loaded with explosives		Vessels loading or unloading explosives	
		barri-caded	unbarri-caded	barri-caded	unbarri-caded
Vessels loaded with explosives		135/90 m(*)	135/90 m (*)	135/90 m (*)	135/90 m (*)
Vessels loading or unloading explosives		135/90 m	135/90 m	135/90 m	135/90 m
Inhabited buildings		bc D7	bc D7	bc D7	bc D7
Public traffic routes and main shipping routes		a D6	a D6	a D6	a D6
POL jetties		180 m	270 m	180 m	270 m

NOTES :

- a) A minimum distance of 90 m may be used for rounds up to 60 m.
- b) A minimum distance of 180 m may be used for rounds up to 60 mm.
- c) D6-distances may be used for isolated dwellings.
- d) A minimum distance of 90 m to be observed for holding areas.

(*)see text

TABLE IV

SUMMARY OF QUANTITY-DISTANCES TO BE OBSERVED FOR SEAGOING
VESSELS LOADED WITH OR LOADING OR UNLOADING EXPLOSIVES

HAZARD DIVISION 1.3

Exposed site \ Potential explosion site	Vessels loaded with explosives		Vessels loading or unloading explosives	
	barri-caded	unbarri-caded	barri-caded	unbarri-caded
Vessels loaded with explosives	60 m	60 m	60 m	60 m
Vessels loading or unloading explosives	60 m	60 m	60 m	60 m
Inhabited buildings	^a D9	^a D9	^a D9	^a D9
Public traffic routes and main shipping routes	D8	D8	D8	D8
POL jetties	60 m	240 m	60 m	240 m

NOTES :

- a) D3-distance may be used for isolated dwellings.
b) A minimum distance of 60 m to be observed for holding areas.

QUANTITY LIMITS FOR THE STORAGE
AND DIRECT DELIVERY OF DANGEROUS GOODS
IN A SEAPORT

Class	Sub-Class/Substances	Storage	Direct Delivery
1	1.1/1.5	0.4 tons	5 tons
	1.2	5 tons	20 tons
	1.3/1.4	60 tons	none
2	2.1	200 tons	none
	2.2	none	none
	2.3	80 tons	none
3	3.1	200 tons	none
	Carbon Disulphide UN 1131 Acrolein UN 1092 Acrylonitrile UN 1093	Total of 200 tons	2000 tons
	3.2	200 tons	none
	3.3	none	none
4	4.1	100 tons	none
	4.2	300 tons	none
	4.3	300 tons	none
5	5.1	300 tons	none
	Hydrogen Peroxide UN 2015	100 tons	none
	5.2	60 tons	60 tons
	5.2 plus explosive risk	Only with special permit	5 tons
	Acetyl Cyclohexane Sulphonyl Peroxide UN 2082		20 tons
6	6.1	1500 tons	none
	Hydrocyanic Acid UN 1023 Hydrogen Cyanide UN 1614 Acetonitrile UN 1648 (now Class 3) Acetone Cyanohydrin UN 1541 Epichlorohydrin UN 2023 Dimethyl Sulphate UN 1595	Total of 500 tons	none
	Category I	Special permit	Special permit
	Category II	Special permit;	Special permit;
	Category III	Transport index ≤ 200	Transport index ≤ 200
	8		none
9		none	none

From: Port of Hamburg Rules - Summarising Example

For smaller quantities and limited storage only

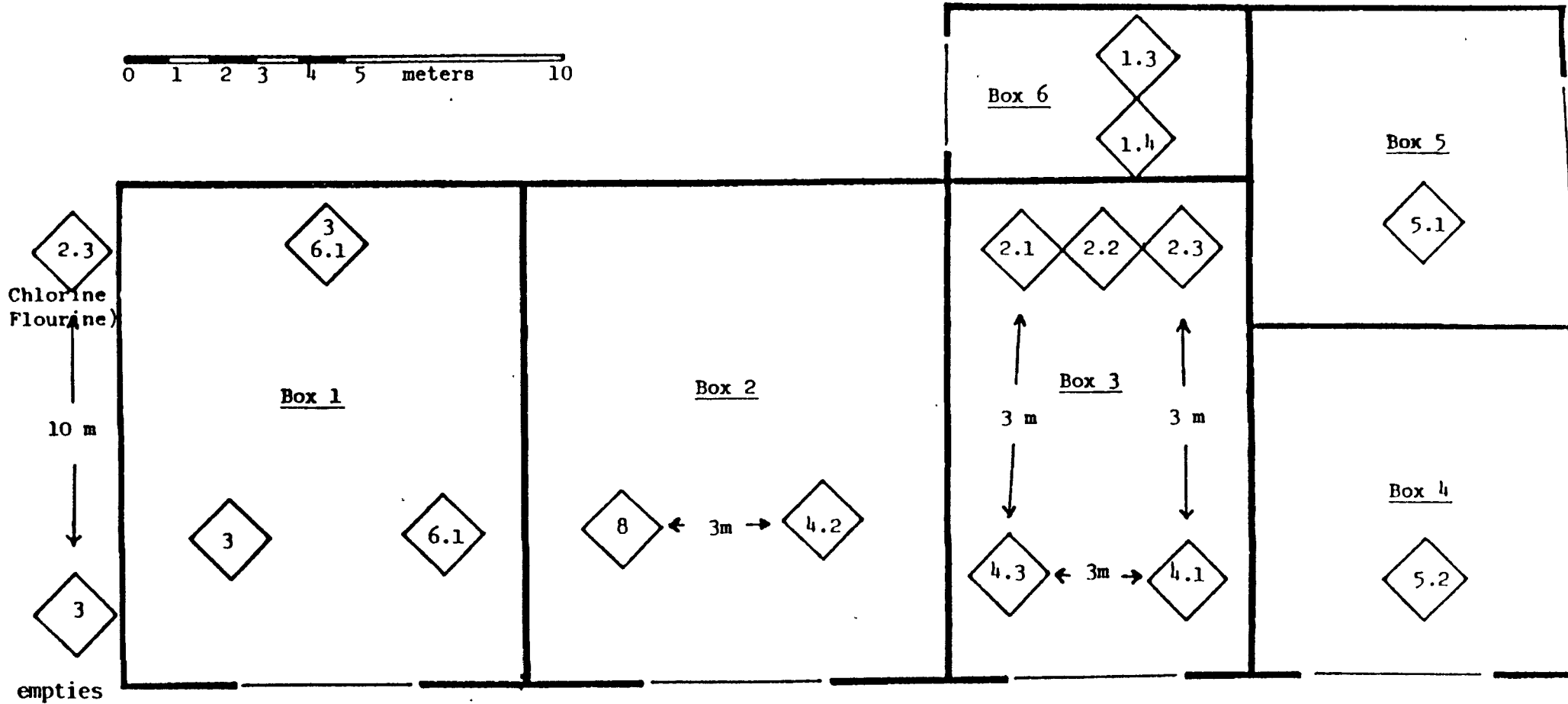
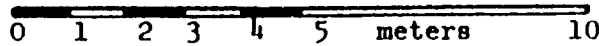

Construction: Solid floor
 Fire resistant walls
 Metal doors
 Light roof
 Closed drainage system

Safety Equipment: Mechanical ventilation)
 (ex-proof))
 (In part Fire detection (fixed))
 alternatively) Fire fighting (water spray)
 and foam)
 Portable extinguishers)
 (chemical)
 Warning signs
 Floor and wall markings

) Controlled from
 outside,
 separately for
 each box

RECOMMENDED MINIMUM SEGREGATION OF

DANGEROUS GOODS IN PORT AREAS

		1.1	1.2	1.3	1.4	2.1	2.2	2.3	3.1	3.2	3.3	4.1	4.2	4.3	5.1	5.2	6.1	7	8	
Explosives	1.1	•	•	•	•	4	2	4	4	4	4	4	4	4	4	4	2	2	4	
Explosives	1.5	•	•	•	•	4	2	4	4	4	4	4	4	4	4	4	2	2	4	
Explosives	1.2	•	•	•	•	4	2	4	4	4	4	4	4	4	4	4	2	2	4	
Explosives	1.3	•	•	•	•	4	2	4	4	3	3	4	4	4	4	4	2	2	2	
Explosives	1.4	•	•	•	•	2	1	2	2	2	2	2	2	2	2	2	X	2	2	
Inflammable gases	2.1	4	4	4	2	2	X	2	2	1	2	1	2	1	2	4	X	2	1	
Other than inflammable gases	2.2	2	2	2	1	X	2	2	X	1	X	X	2	X	2	X	1	X		
	2.3	2	2	2	1	X	2	2	X	1	X	X	2	X	2	X	1	X		
Inflammable liquids	3.1	4	4	4	2	2	2	2	2	2	2	2	2	2	2	3	X	2	2	
	3.2	4	4	4	2	2	2	2	2	2	2	2	2	2	2	3	X	2	2	
Inflammable liquids	3.3	4	4	4	2	2	2	2	2	2	2	1	2	2	2	3	X	2	1	
Inflammable solids	4.1	4	4	3	2	1	X	2	1	2	1	2	1	1	1	2	X	2	1	
Spontaneously combustible substances	4.2	4	4	3	2	2	1	2	2	1	2	1	2	1	2	2	X	2	1	
Substances which are dangerous when wet	4.3	4	4	4	2	1	X	2	2	1	1	2	1	1	2	2	X	2	1	
Oxidizing substances	5.1	4	4	4	2	2	X	2	2	1	2	1	2	2	2	2	1	1	2	
Organic peroxides	5.2	4	4	4	2	4	2	3	3	2	2	2	2	2	2	2	1	2	2	
Poisons	6.1	2	2	2	X	X	X	X	X	X	X	X	X	X	1	1	X	X	X	
Radioactive substances	7	2	2	2	2	2	1	2	2	2	2	2	2	2	1	2	X	2	2	
Corrosives	8	4	4	2	2	1	X	2	1	1	1	1	1	1	2	2	X	2	2	
Miscellaneous dangerous substances	9	No general segregation recommended; individual schedules should be consulted.																		

- 1. 3 m
- 2. 10 m
- 3. 30 m
- 4. In different warehouses or separated by fire resistant walls; in the open at least 30 m distance
- X No general segregation recommended; individual schedules should be consulted.

Dangerous goods with toxic properties should be stored at least 10 m from all foodstuffs.

For segregation of Class 7 - radioactive substances - see Appendix 3 of the IMO Recommendations on the Safe Transport, Handling and Storage of Dangerous Substances in Port Areas.

GRAPH SHOWING FIRE INCIDENT ATTENDED BY
K.P.T. FIRE SERVICE FROM 1981 TO 1988

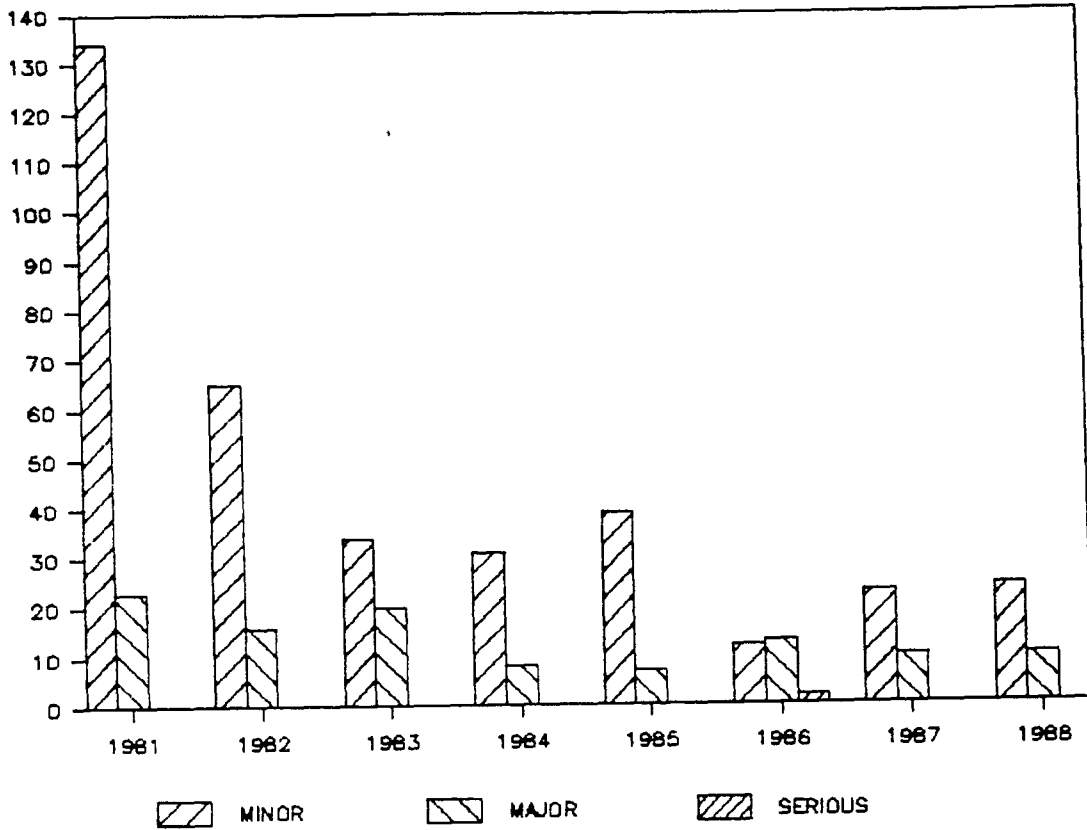

STATEMENT SHOWING THE LOSS OF LIFE
AND PROPERTY BY FIRES

S/NO.	DATE & TIME	ADDRESS AND FULL PARTICULARS OF PROPERTY AFFECTED.	NO. AND TYPE OF APPLIANCES DEPLOYED.	NO. OF PERSONS TRAPPED.	NO. OF PERSONS RESCUED.	NO. OF PERSONS INJURED/DEAD.	VALUE OF PROPERTY SAVED.	VALUE OF PROPERTY DESTROYED.	CAUSE OF FIRE	REMARKS
1	2	3	4	5	6	7	8	9	10	11
1.	07.01.1988 at 15.38 Hours.	Field No.2 of s.v."PROSPERITY" berthed at No.4, East Wharf.	3 Fire Tenders.	Nil.	Nil.	Nil.	Million of Rupees.	Rs.10,00,000/- approx	Could not be ascertained.	
2.	20.01.1988 at 01.05 Hours.	Naval Stores Dockyard	2 Fire Tenders.	Nil.	Nil.	Nil.	Millions of Rupees.	Damage will be assessed by the Naval Authorities.	Could not be ascertained.	(Outside the limit)
3.	15.01.1988 at 10.40 Hours.	Railway Track loop lines near Calico Terminal, Kasmari in Railway Tenders full of H.S.D. Oil.	7 Fire Tenders from from K.P.T. 2 Fire Tenders of K.M.C. 2 Fire Tenders of Pakistan Navy and 1 from Pakistan Rly. Total 12 Fire Tenders.	Nil.	Nil.	Nil.	Millions of Rupees.	Rs.80,00,000/- approx.	Could not be ascertained.	(Outside the limit)
4.	20.02.1988 at 04.45 Hours.	Railway Engine No.ALU-12- 3717 at Berth No.10, East Wharf.	2 Fire Tenders.	Nil.	Nil.	Nil.	Millions of Rupees.	Rs.10,000/- approx.	Overheating of Cables.	
5.	14.3.1988 at 19.06 Hours.	Plinth No.F-3, TPX in Cotton Bales.	9 Fire Tenders.	Nil.	Nil.	Nil.	Millions of Rupees.	Rs.1,00,000/- approx.	Could not be ascertained.	
6.	17.3.1988 at 11.35 Hours.	Plinth No.B-12, TPX. in Cotton Bales & Licorice Roots.	12 Fire Tenders.	Nil.	Nil.	Nil.	Millions of Rupees.	Rs.20,00,000/- approx.	Could not be ascertained.	
7.	30.3.1988 at 05.00 Hours.	Plinth No.B-10,TPX in Cotton Bales.	12 Fire Tenders.	Nil.	Nil.	Nil.	Millions of Rupees.	Rs.15,00,000/- approx.	See Could not be ascertained.	

STATEMENT SHOWING THE LOSS OF LIFE
AND PROPERTY BY FIRE.

S/NO.	DATE & TIME	ADDRESS AND FULL PARTICULARS OF PROPERTY AFFECTED.	NO. AND TYPE OF APPLIANCES DEPLOYED.	NO. OF PERSONS TRAPPED.	NO. OF PERSONS RESCUED.	NO. OF PERSONS INJURED/ DEAD.	VALUE OF PROPERTY SAVED.	VALUE OF PROPERTY DESTROYED.	CAUSE OF FIRE.	REMARK
1	2	3	4	5	6	7	8	9	10	11
1.	05.4.1988 at 18.10 Hrs.	Railway Engine No. DE-3739 at Berth No. 18, West Wharf.	2 Fire Tenders	-	-	-	Millions of Rupees.	Rs. 10,000/- approx.	Overheating of the Cable.	
2.	04.5. 1988 at 17.10 hours.	Life Boat of M.V. "OIRMUZED" AT Berth No. 17, East Wharf.	4 Fire Tenders.	-	-	-	Millions of Rupees.	Rs. 20,000/- approx.	Could not be ascertained.	
3.	04.5.1988 at 17.10 Hours.	Rly. Wagon No. KC-68771 in Raw Sulphur at Rly. Yard, N.M.B. Wharf.	2 Fire Tenders.	-	-	-	Millions of Rupees.	Rs. 5,000/- approx.	Could not be ascertained.	
4.	06.6. 1988 at 19.40 hours.	Sui-Gas Pipeline, near Sagaras Chowk, Maughopir Road, Karachi.	2 Fire Tenders.	-	-	-	assessed by the Civil Authorities.	Assessed by the Civil Authorities.	Could not be ascertained.	Outside the Port Limits.
5.	23.6.1988 at 05.12 Hours.	Condemned Boat of Fibre near P.W.I's Stores, Opp: Coast Guard Head Quarter, Keamari.	4 Fire Tenders.	-	-	-	-do-	-do-	Could not be ascertained.	

3/88
Port Fire Officer,
KARACHI PORT TRUST

STATEMENT SHOWING THE LOSS OF LIFE
AND PROPERTY BY FIRE:

Period from: 01-7-1988 to 30-09-1988.

S/NO.	DATE & TIME	ADDRESS AND FULL PARTICULARS OF PROPERTY AFFECTED:	NO. AND TYPE OF APPLIANCES DEPLOYED.	NO. OF PERSONS TRAPPED:	NO. OF PERSONS RESCUED.	NO. OF PERSONS INJURED/DEAD.	VALUE OF PROPERTY SAVED:	VALUE OF PROPERTY DESTROYED.	CAUSE OF FIRE.	REMARKS
1	2	3	4	5	6	7	8	9	10	11
1.	27.7.1988 at 10.31 Hours.	Oil Pier-I Jetty in insulation of wires/cables of Electric Pole.	1(Foam Tender)	-	-	-	Million of Rupees.	Rs.5,000/- approx:	Short Circuiting.	
2.	27.7.1988 at 22.29 Hours.	Flinth C-7,TPX on Main Road in insulation of wires/cable.	Four(Fire Tenders)	-	-	-	Millions of Rupees.	Rs.5,000/- approx:	Short Circuiting.	
3.	06.8.1988 at 11.00 Hours.	M.V."ALI-NOWSKI" berthed at Berth No.21,West Wharf.	2(Fire Tenders)	-	-	-	Million of Rupees.	Rs.10,00/- approx.	Short Circuiting.	
4.	10.8.1988 at 21.40 Hours.	Transit Shed No.2,East Wharf in Search Light Tower.	1(Fire Tender)	-	-	-	Million of Rupees.	NIL.	Short Circuiting.	
5.	10.8.1988 at 14.45 Hours.	Nairang Shopping Centre, Liaquatabad, Karachi.	4(Fire Tenders)	-	-	-	Assessed by the Civil Authorities.	Assessed by the Civil Authorities.	Could not be ascertained.	
6.	11.8.1988 at 18.00 Hours.	M.V."SUNDERBAN" at S.R.B..	4(Fire Tenders)	-	-	-	Million of Rupees.	Rs.10,000/- approx:	Cutting & sliding Sparks.	
→ 7.	05.9.1988 at 11.45 Hours.	M.I.Yard in Cotton Bales.	1(Fire Tender)	-	-	-	Million of Rupees.	Rs.500/- approx:	Friction by the Iron Hoops.	
→ 8.	06.9.1988 at 13.25 Hours.	Trailer No.LS-1795 stationed outside TPX Gate No.1 in cotton bales.	1(Fire Tender)	-	-	-	Million of Rupees.	Rs.50,000/- approx:	Could not be ascertained.	
9.	20.9.1988 at 20.05 Hours.	Outside the Boundry wall, M.T.Khan Road, in rubbish.	8(Fire Tenders)	-	-	-	-	-	Could not be ascertained.	
→ 10	27.9.1988 at 00.31 Hours.	Flet No.W-13, New TPX in Cotton Bales	9(Fire Tenders)	-	-	-	Million of Rupees.	Rs.5,00,000/- approx:	-do-	

5/x/88.
PORT FIRE OFFICER
KARACHI PORT TRUST.

STATEMENT SHOWING THE LOSS OF LIFE AND PROPERTY BY FIRE:

S/NO	DATE & TIME	ADDRESS AND FULL PARTICULARS OF PROPERTY AFFECTED.	NO. AND TYPE OF APPLIANCES DEPLOYED:	NO. OF PERSONS TRAPPED:	NO. OF PERSONS RESCUED.	NO. OF PERSONS INJURED/DEAD.	VALUE OF PROPERTY SAVED:	VALUE OF PROPERTY DESTROYED.	CAUSE OF FIRE	REMARKS:
1	2	3	4	5	6	7	8	9	10	11
1.	03-10-1988 at 21.10 Hours.	Seaside opp: M/S. H.P.I. Lulk Terminal Complex, Keamari in rubbish.	One Fire Tender.	-	-	-	-	-	Could not be ascertained.	
2.	05-10-1988 at 16.15 Hours.	Sea side opp: M/S F & B Terminal, Keamari in rubbish.	Two Fire Tenders.	-	-	-	-	-	do	
3.	08-10-1988 at 09.32 Hours.	D.C. Shed, N.M.B. Wharf in sand mixed with various types of solid chemical.	One Fire Tender.	-	-	-	-	-	Chemical Reaction.	
4.	10-10-1988 at 10.12 Hours.	Custom Office at Transit Shed No.16, East Wharf in sample of the Petroleum Benzine Extra pure in the Liquid form (smouldering)	Dry Chemical Fire Extinguisher.	-	-	-	-	-	Ignition by the Candle.	
5.	30-10-1988 at 01.40 Hours.	Sanitary Office, KPT Hospital.	One Fire Tender.	-	-	-	Rs.50,000/-	Rs.2,000/-	Overheating of wires & switches.	
6.	02-11-1988 at 20.38 Hours.	Open rainn opp: S.R.B. in Scrap Rubber Tyres & Tubes etc.	Five Fire Tenders.	-	-	-	Million of Rupees.	Rs.1,00,000/- approx:	Could not be ascertained.	
7.	28.11.1988 at 16.42 Hours.	Vacant Plot, Oil Installation area, Keamari in rubbish.	One Fire Tender.	-	-	-	-	-	do	
8.	03-12-1988 at 01.20 Hours.	Quay Crane No.1 at Berth No.1, East Wharf.	One Fire Tender.	-	-	-	Million of Rupees.	Rs.04,000/- approx:	Short Circuiting.	
9.	03-12-1988 at 14.25 Hours.	Pipeline Trench opp: M/S. Pakistan Lubricant (Pvt) Ltd, Keamari in pipeline.	Five Fire Tenders.	-	-	-	Million of Rupees.	Rs.1,00,000/- approx:	Welding Sparks.	
10.	12-12-1988 at 05.51 Hours.	Wooden Railway Slippers, opp: Pakistan Coast Guards Office, Keamari.	One Fire Tender.	-	-	-	-	-	Could not be ascertained.	
11.	27.12.1988 at 16.40 hours.	Private Car at West Wharf.	Two Fire Tenders.	-	-	-	Millions of Rupees.	Rs.1,000/-	Short Circuiting.	

[Signature]
7/1/89
FOOT FILE OFFICER

ANNEX 1
PAGE 9

Big rise in dangerous cargoes 'key concern'

KARACHI, Sept. 18: The Minister of State for Communications Sardar Fa'ez Mohammad Hasni on Sunday called for taking appropriate measures for ensuring safety during handling and carriage of dangerous cargoes.

He was inaugurating a seminar on the subject of transport, handling and storage of dangerous and harmful substances at sea and in port areas and their onward transfer by other modes of transport at Karachi Port Trust Staff College.

The seminar was held under the auspices of International Maritime Organisation (IMO) and the United Nations Development Programme (UNDP).

Mr Hasni said that the carriage of dangerous cargoes by sea has become major concern for all those involved in sea transport, whether it is the shipper, the carrier, the port the consignee or any other member of the shipping industry.

This concern, he said, was due to the fact that the transport of dangerous cargoes had changed its pattern during the last three decades. Not only has the quantities of dangerous cargoes carried in ships multiplied, but the variety of these cargoes has also increased tremendously.

Mr. Hasni said that the statistical figures of all dangerous cargoes, indicated that of today's world trade of well over billion tons of cargo which passes through ports and terminals every year, more than 50 per cent falls under the category of dangerous and

hazardous cargo.

The increase in quantity and quality of shipments of dangerous goods by sea has not only shown considerable impact on the carrying vehicle—the ship — and caused concern as to its safety but has also consequences for the connecting link between the sea mode of transport and the various land modes ~~of transport~~ transportation.

The Minister said that experience has shown that accidents which are triggered off by the cargo transported normally happened at the handling stages. The port is the main place for transshipments.

The Minister said that ports in developing countries particularly suffer from the problems based on the following:

a) changes in technology and transport specialisation, resulting in the need for specialised facilities and equipment.

b) increased in amount and variety of dangerous substances transhipped through their ports.

c) lack of proper storage facilities for dangerous goods:

d) unskilled labour and lack of training facilities, training funds and specially trained instructors:

e) outdated port regulations:

f) extensions of ports which very often are not in line with the original ideas conceived when the layout of the port was planned and where remote areas dedicated as "hazardous corners" of the port become the centre of activities due to expansion outside the control of the port.—APP

REGISTERED No. S. 1033

The Gazette of Pakistan

EXTRAORDINARY
PUBLISHED BY AUTHORITY

KARACHI, MONDAY, NOVEMBER 19, 1984

PART II

Statutory Notifications containing Rules and Orders issued by all Ministries and Divisions of the Government of Pakistan and their Attached and Subordinate Offices and the Supreme Court of Pakistan

GOVERNMENT OF PAKISTAN
MINISTRY OF COMMUNICATIONS

(Ports and Shipping Wing)

NOTIFICATION

Karachi, the 1st October 1984

S.R.O. 43(KE)84:

In exercise of the powers conferred by clauses (a) to (o) of sub-section (1) of section 6 of the Ports Act, 1908 (XV of 1908), the Federal Government is pleased to direct that the following further amendment shall be made in the Karachi Port Rules, the same having been previously published as required by sub-section (2) of the said section, namely:—

In the aforesaid Rules, after rule 91-A, the following new rule shall be inserted, namely:—

“91-B” All dangerous goods shall be handled at the Port of Karachi as per IMO International Maritime Dangerous Goods Code (IMDG Code) Classifications, as amended from time to time, in accordance with the following rules:—

- (1) Class 1 category of goods pertains to the explosives only and shall, as at present, continue to be discharged at Berths No. 24 and 21 which berths are indemnified by the Government.
- (2) Dangerous goods of Class 2 and Class 3 which pertain to inflammable liquids and gases should continue to be transported to the Dangerous goods shed hereinafter in this rule referred to as D.G. shed, by barges only.
- (3) Dangerous goods of Classes 4, 5, 6, 8 and 9 if in containers (20 ft. or 40 ft. PCL or LCL) may be transported to D.G.

Price : Rs. 20

Shed direct by trucks or trailers except dangerous cargo having Flash Point below 91 degrees F which may be transported by barges only.

- (4) All such containers allowed by road shall be put in trucks or trailers from the ship for transportation direct to D.G. Shed. No container shall be allowed to be kept on the plinth. All containers should be transported to D.G. Shed before dark hours and parked temporarily for the night at places within the compound of D.G. Shed at NMB Wharf or as directed by the Traffic Manager, KPT, up to the maximum of 25 containers. Such containers should be destuffed immediately the following day. All arrangements at D.G. Shed shall be made by the Shipping Agents prior to discharge of containers from the vessels.
- (5) Dangerous goods of Class 7 which pertains to radio-active substances shall be handled in accordance with the instructions of the Pakistan Atomic Energy Commission.
- (6) Poisonous substances, i.e., pesticides and insecticides of Class 8 in solid form may be allowed to be stacked on open plinths and may be allowed direct delivery to the consignees. Poisonous substances i.e., pesticides and insecticides of Class 8 in solid form and non-inflammable corrosive substances falling under Class 6 shall be allowed to be stacked at the North-end-overflow plinth of NL Berth, West Wharf, in an area specially earmarked for this purpose by the Traffic Manager. On these goods storage charges shall be levied as for the D.G. Shed on East Wharf.
- (7) Direct delivery of all classes of dangerous cargo shall be allowed from barges to the consignees on fulfilment of requisite formalities and after taking due precautions as provided in the rules applicable to explosive dangerous cargo, from Berth No. 18-A and 24 SE, West Wharf, which are duly notified for the purpose of handling of commercial explosives and dangerous cargo.
- (8) DPT (Blowing Agent) discharged overside into barges shall remain in the dangerous cargo barges till such time as the consignees arrange direct delivery of same from barges. Normal rules applicable to explosive cargo shall also apply to DPT consignments. However, these would be subject to storage charges under normal rules applicable to D.G. Shed cargo.
- (9) Hydrogen Peroxide (H_2O_2) which falls in Class 5 and IMDG Code shall be stored under Leanto of Transit Sheds at East and West Wharves in order to provide covered shelter to this commodity so as to prevent its exposure to water and atmosphere."

[File No. P. IH-1(4)'84.]

M. NAEEM BEG.

S. BT.,

Commodore P.N.

Joint Secretary and Director General.

Navy store gutted

By Our Staff Reporter

KARACHI, Jan 31: Fire broke out in a Navy store at West Wharf around 7 p.m. on Tuesday.

Consequently, over two dozen fire tenders from all KMC stations, KPT and Navy, were rushed to the scene.

Since chemical drums including that of paints and varnishes were stored, Fire Brigade sources said foam was used to quell the flames which were still raging midnight.

City fire not yet extinguished

By Our Staff Reporter

KARACHI, Feb 1: Acute water shortage in Karachi hampered fire-fighting efforts at West Wharf, off the port, where a huge dump of Pakistan Navy paints are on fire for the past 31 hours.

About 30 fire tenders from all the civic agencies, including KMC and KPT, and Pakistan Navy were involved in extinguishing the fire.

Almost all KMC sources went dry during the acute water shortage because of closure of main supply from Indus sources for the past many weeks and KMC fire tenders remained idle and did

not participate in fire-fighting efforts.

Repeated requests from KMC high officials, particularly by senior fire officers, officials of the KPT and Pakistan Navy did not allow the tender to refill the tankers from KMC for hours. As a result, the fire continued to rage and went out of control on Tuesday night.

The fire broke out around 6 p.m. on Tuesday and the KMC tenders were permitted to use water from other sources by 10 p.m. by that time, much damage was caused to

the paints dumps and the building itself.

Similarly, the fire tenders from all other agencies, started using sea water in extinguishing the fire.

The fire was, however, contained on Wednesday mid-night and officials claimed that they would be able to extinguish it by Thursday forenoon.

Property worth about tens of millions of rupees had been destroyed and the building extensively damaged. No official version of the fire was available from the concerned authorities.

5,000 cotton bales gutted

By Our Staff Reporter

KARACHI, Feb 2: Hundreds of cotton bales were gutted as fire broke out in a textile mills in Landhi on Thursday.

Over 0.1 million bales of cotton were dumped in an open plot within the premises of the mills where fire broke out in the morning and soon raged to high flames. About a dozen fire tenders rushed on the spot and extinguished the fire after seven hours operation.

According to preliminary estimates, around 5,000 cotton bales were gutted in the fire.

CHEMICALS: The fire, which was raging in the Pakistan Navy's chemical store, off the port, in West Wharf area was brought under control.

Most of the 30 fire tenders of KMC and KPT were withdrawn af-

ter it was considerably contained within the store limits. However, the fire tenders of the Pakistan Navy were busy in extinguishing the fire till Thursday afternoon.

The cause of fire could not be known.

Meanwhile, the KMC officials were found busy in cleaning the pumps of the fire tenders which suffered damage while extinguishing the fire in West Wharf.

PETROL PUMP: A petrol pump caught fire on the Hub River Road late on Thursday night. The cause of fire could not be known immediately.

A number of KMC fire tenders were busy in extinguishing the fire till our going to press on Thursday night.

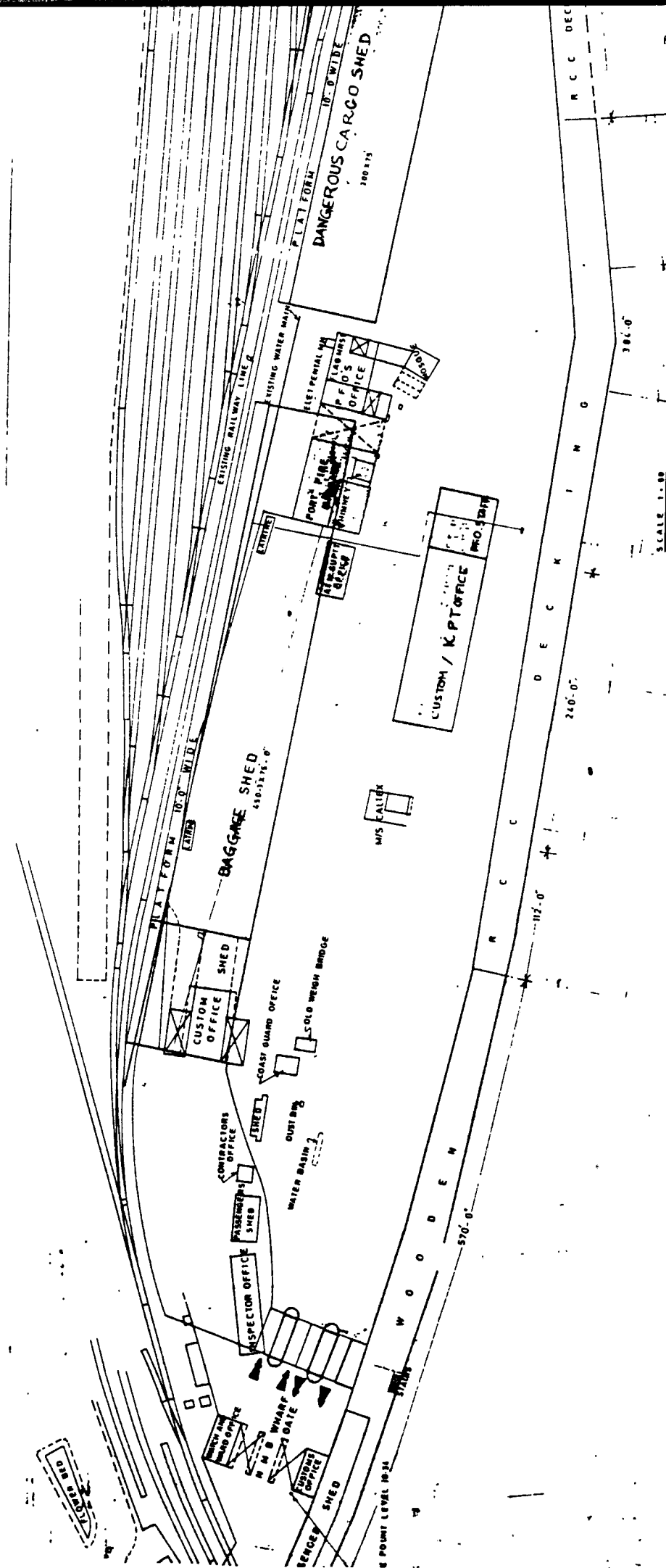

R C C DEC

D E C K I M G

R C C

W O O D E N

S POINT LEVEL 10-21

SCALE 1:100

