

The University of Akron

IdeaExchange@UAkron

Williams Honors College, Honors Research
Projects

The Dr. Gary B. and Pamela S. Williams Honors
College

Spring 2020

E-Z Door: Hands-free Front Door Unlocking and Opening Mechanism

Caleb Dyck
cjd97@zips.uakron.edu

Follow this and additional works at: https://ideaexchange.uakron.edu/honors_research_projects



Part of the [Controls and Control Theory Commons](#), [Other Electrical and Computer Engineering Commons](#), and the [VLSI and Circuits, Embedded and Hardware Systems Commons](#)

Please take a moment to share how this work helps you [through this survey](#). Your feedback will be important as we plan further development of our repository.

Recommended Citation

Dyck, Caleb, "E-Z Door: Hands-free Front Door Unlocking and Opening Mechanism" (2020). *Williams Honors College, Honors Research Projects*. 1157.

https://ideaexchange.uakron.edu/honors_research_projects/1157

This Dissertation/Thesis is brought to you for free and open access by The Dr. Gary B. and Pamela S. Williams Honors College at IdeaExchange@UAkron, the institutional repository of The University of Akron in Akron, Ohio, USA. It has been accepted for inclusion in Williams Honors College, Honors Research Projects by an authorized administrator of IdeaExchange@UAkron. For more information, please contact mjon@uakron.edu, uapress@uakron.edu.

Honors Research Project Proposal

Please Print

Name: Caleb Dyck	Student ID: 4006699
Email (@zips.uakron.edu): cjd97	
Title of Proposed Project: E-Z Door	
Major: Electrical Engineering	Graduation (semester/year): Spring 2020

Please include a brief (maximum 200 words) summary of your proposed project

This project is to design a hands-free system to unlock and open the front door of a house using 2-factor authentication.

The E-Z Door senior design project is to help people with physical limitations to be able to take advantage of technology to make entering the house significantly easier.

Approval:

Honors Course No.:	No. of Project Credits:									
<table style="width: 100%;"> <tr> <td style="width: 20%;">Honors Project Sponsor</td> <td style="width: 30%;"><i>Maleki</i></td> <td style="width: 50%;">10/1/2019</td> </tr> <tr> <td>Signature/Date</td> <td></td> <td></td> </tr> <tr> <td>Print name</td> <td>Maleki</td> <td>Email: mm158@uakron.edu</td> </tr> </table>		Honors Project Sponsor	<i>Maleki</i>	10/1/2019	Signature/Date			Print name	Maleki	Email: mm158@uakron.edu
Honors Project Sponsor	<i>Maleki</i>	10/1/2019								
Signature/Date										
Print name	Maleki	Email: mm158@uakron.edu								
<table style="width: 100%;"> <tr> <td style="width: 20%;">Reader</td> <td style="width: 30%;"><i>[Signature]</i></td> <td style="width: 50%;">9/20/19</td> </tr> <tr> <td>Signature/Date</td> <td></td> <td></td> </tr> <tr> <td>Print name</td> <td>Bregory A. Lewis</td> <td>Email: glewis@uakron.edu</td> </tr> </table>		Reader	<i>[Signature]</i>	9/20/19	Signature/Date			Print name	Bregory A. Lewis	Email: glewis@uakron.edu
Reader	<i>[Signature]</i>	9/20/19								
Signature/Date										
Print name	Bregory A. Lewis	Email: glewis@uakron.edu								
<table style="width: 100%;"> <tr> <td style="width: 20%;">Reader</td> <td style="width: 30%;"><i>[Signature]</i></td> <td style="width: 50%;">30 Sep 2019</td> </tr> <tr> <td>Signature/Date</td> <td></td> <td></td> </tr> <tr> <td>Print name</td> <td>R Veillette</td> <td>Email: veillette@uakron.edu</td> </tr> </table>		Reader	<i>[Signature]</i>	30 Sep 2019	Signature/Date			Print name	R Veillette	Email: veillette@uakron.edu
Reader	<i>[Signature]</i>	30 Sep 2019								
Signature/Date										
Print name	R Veillette	Email: veillette@uakron.edu								
<table style="width: 100%;"> <tr> <td style="width: 20%;">Honors Faculty Advisor</td> <td style="width: 30%;"><i>Maleki</i></td> <td style="width: 50%;">9/26/2019</td> </tr> <tr> <td>Signature/Date</td> <td></td> <td></td> </tr> <tr> <td>Print name</td> <td>Maleki</td> <td>Email: mm158@uakron.edu</td> </tr> </table>		Honors Faculty Advisor	<i>Maleki</i>	9/26/2019	Signature/Date			Print name	Maleki	Email: mm158@uakron.edu
Honors Faculty Advisor	<i>Maleki</i>	9/26/2019								
Signature/Date										
Print name	Maleki	Email: mm158@uakron.edu								

Your approved cover sheet and proposal must be submitted to the Williams Honors College through IdeaExchange

E-Z Door

Caleb Dyck (Honors), Brice Brenneman, Justin Gnatiuk, Mitch Wilson

Department of Electrical Engineering

Honors Research Project

Submitted to

*The Williams Honors College
The University of Akron*

Approved:

Date:

Honors Project Sponsor (signed)

Honors Project Sponsor (printed)

Date:

Reader (signed)

Reader (printed)

Date:

Reader (signed)

Accepted:

Date:

Honors Department Advisor (signed)

Honors Department Advisor (printed)

Date:

Department Chair (signed)

Department Chair (printed)

Reader (printed)

Senior Design Project Individual Responsibilities

Caleb Dyck

- Embedded Coding - I have written all of the embedded code for the senior design project, including:
 - Pulse Width Modulation code
 - Bluetooth Communication Protocol code on the microcontroller
 - LCD display code
 - Analog to Digital Conversion code (to read in raw data from a microphone)
- Circuit design - worked with my team in developing circuit designs for the DC-DC Buck converter circuit and the Solenoid lock circuit.
- Circuit Implementation – helped solder the DC-DC Buck converter circuit and the DC H-Bridge motor circuit.
- Phone Application – began work creating an application that would connect to the board via Bluetooth – when the other team member took over the application design, I had just figured out how to connect the application to the board successfully.
- Project Lead – delegation of subsystems, integration, time, and sub-teams for the entire project.

E-Z Door Project

Project Design Report

Design Team 11

Brice Brenneman, EE

Caleb Dyck, EE

Justin Gnatiuk, CPE

Mitch Wilson, CPE

Faculty Advisor: Mehdi Maleki Pirbazari

April 2, 2020

Table of Contents

Abstract.....	8
1. Problem Statement.....	9
1.1. Need.....	9
1.2. Objective.....	9
1.3. Background.....	10
1.4. Marketing Requirements.....	15
2. Engineering Analysis.....	16
2.1. Electromechanics.....	16
Equation 2.1.1:.....	16
Equation 2.1.2:.....	17
Equation 2.1.3:.....	17
2.2. Power.....	20
2.3. Embedded Systems & Communications.....	20
2.4 Digital Signal Processing.....	24
3. Design Requirements Specification.....	25
3.1. Engineering Requirements.....	25
4. Engineering Standards Specification.....	26
Communication.....	26
• Universal Serial Bus (USB).....	26
• Bluetooth.....	26
• IEEE 802.11.....	26
• RS-232.....	26
Programming Languages.....	26
• Bash.....	26
• C (Embedded).....	26
• Python.....	26
Connector Standards.....	26
• USB.....	26
5. Accepted Technical Design.....	27
5.1 Hardware Design.....	27

5.2. Software Design.....	34
6. Mechanical Sketch	45
7. Team Information.....	46
8. Parts List.....	47
8.1 Accepted Technical Design Parts List.....	47
8.2 Bill of Materials.....	48
9. Project Schedule.....	49
10. Conclusions.....	50
11. References.....	51
12. Appendix.....	53
A. Explorer 16/32 Product Information.....	53
B. Servo Motor Datasheet	53
C. Buck Converter Datasheet	53

List of Figures

Figure 1: Objective Tree	10
Figure 2: Door Opening Diagram	18
Figure 3: Hardware Block Diagram - Level 0	27
Figure 4: Hardware Block Diagram - Level 1	27
Figure 5: Power Supply Schematic	32
Figure 6: Voice Recognition Module Schematic	33
Figure 7: Software Block Diagram - Level 0.....	34
Figure 8: Software Block Diagram - Level 1.....	35
Figure 9: Software Block Diagram - Level 2.....	36
Figure 10: Mechanical Sketch	45
Figure 11: Gantt Chart DT11, Fall Semester 2019	49

List of Tables

Table 1: Wireless Communications	22
Table 2: Engineering Requirements.....	25
Table 3: Bluetooth Receiver Functional Requirement.....	28
Table 4: Microphone Functional Requirement	28
Table 5: Power Supply Functional Requirement	28
Table 6: Battery Backup Functional Requirement.....	29
Table 7: Lock/Unlock Functional Requirement.....	29
Table 8: Open/Close Servo Functional Requirement.....	29
Table 9: Microcontroller Functional Requirement	30
Table 10: Parts List	47
Table 11: Bill of Materials.....	48

Abstract

JG - Automatic door entry systems are a technology that have been employed for many years, most notably in commercial/public buildings. Their significance may be overlooked by an able-bodied person outside of convenience, but for the disabled community they are significantly useful. There is one subset of buildings where automatic door entry systems are not employed, and that is within residential buildings. This project aspires to implement a residential, two-factor security authentication system with a hands-free automatic door opening mechanism.

1. Problem Statement

1.1. Need

CD - In an age of technology where so much has changed in the past 3 decades, there is still a realm of everyday life that, for the normal person, has remained unaffected - most houses and buildings have doors that are still equipped with a physical handle, lock, and key. This method of securing and opening a door is a hindrance in many different situations for many different people. There are multiple situations where this could be an issue: if an elderly person with a wheelchair/walker wants to open their closed and locked door, it can be a major challenge to move in such a way as to be able to open the door from the wheelchair. Another situation is for people who are moving large boxes or furniture - if someone lives in a location where it isn't viable to keep the door unlocked or open for periods of time, it can be very difficult to try to unlock and open a door while moving awkward or heavy items.

1.2. Objective

BB - This proposal, presented to solve the problems as stated above, is to design and implement a door locking/unlocking and opening system that removes the need for any key or physical interaction with the lock. This would be accomplished through the means of a two-phase unlocking system. One would be through some method of identification - that could be through a Bluetooth connection with the user's phone, or with some kind of geolocation using the GPS location of the user, or with the use of an RFID tag or some other method of identification. The other method would be through specific user input - this might be accomplished through a keyword password (through the implementation of a microphone input). The opening of the door, automatically, could be achieved in a variety of ways, one of which being the use of a mechanical arm/device mounted to the door.

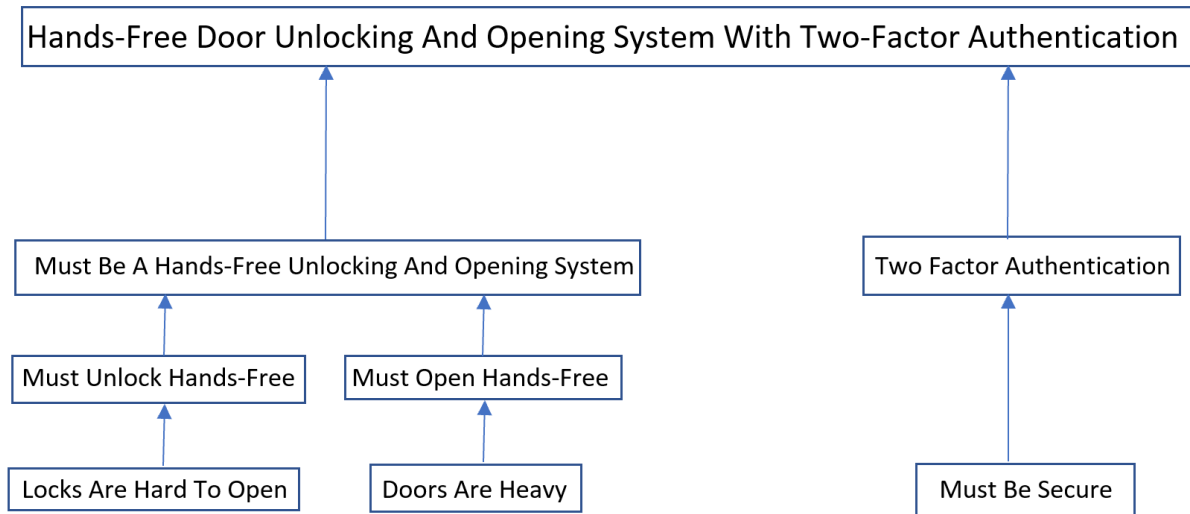

Figure 1: Objective Tree

-CD

1.3. Background

BB - The basic theory behind the E-Z Door concept is to create a system that will replace the mechanical locking mechanism of a household door with an electromechanical locking/unlocking device that will also physically open the door for the user. This device will utilize a two-step verification process through which the user would be able to unlock the door and have the door open automatically. The specific means of identity authentication would allow for hands-free, user access to the door for a specific group of people. There are many examples of where this system would be superior to the standard mechanical key locks most doors are currently using. First, this system would be beneficial for elderly/handicapped individuals who might have limited dexterity or other physical limitations. Second, this system would allow for the elimination of physical keys, which have the tendency to get lost or misplaced. Third, this system would also allow the user to unlock and open their door while having their hands full.

These are just a few of the many scenarios where the E-Z Door system would be superior to current mainstream mechanical locking mechanisms. In addition, this system could offer customizable security options, multiple person access, and many other features depending on the needs and desires of the user.

CD - There are a few similar device concepts existing that pertain to the use of phones and speech recognition to unlock a door, but research shows that the systems that have been designed before have all ended up falling short in the realm of pure hands-free technology. A proposal from a group of researchers from the ARPN Journal of Engineering and Applied Sciences has this to say on the subject: “Rather than using a key, it uses a command that is delivered digitally via Bluetooth on Smartphone and other mobile devices.”^[1] This approach implements the idea of remotely unlocking a door through the use of Bluetooth technology, but it still requires a PIN code to be entered by the user. Another approach, this one from a 2014 IEEE conference, is to use “Short Message Service Text Messaging (SMS) as a mechanism to control the system via mobile phone to lock and unlock the door.”^[2] This approach has the same drawbacks as the previous approach, in that it still lacks the true hands-free approach sought after in this proposal. The technique of using speech recognition is used in conjunction with a user-entered PIN to unlock the door, but as in the previous case, there is still a lack of hands-free use.

CD - There are some limitations with the current existing system concepts. The first type of drawbacks in existing systems can be seen in the aspect of security. From a report in the 2018 International Conference on Information and Communications Technology, “The authentication is using speech command or pin code. Users can choose one of it [them] from the android application.”^[3] This is a security weakness, as there are more ways for people to get into the system. Another drawback in current systems can be found in a paper from IEEE, published in 2009. “Once the person is authenticated through password or RFID tag, the door lock is opened.”^[4] Again, this is a security risk - if someone found the RFID tag, they would be able to get into the house with no other measures of authentication.

CD - Another type of drawback comes from the ways the user must interact with the system. As a report published in the ARPN Journal of Engineering and Applied Sciences states, “Controlling

[is] conducted by sending a command via Bluetooth to the Arduino circuit that acts as a connection between Android smart phone and solenoid.” [1] The user must physically send a PIN from the Bluetooth app on the user’s phone, which can then be used as a means of accepting the PIN and opening the solenoid lock. This method of entering a PIN on the user’s phone has two negative impacts; it requires the user to pull out their phone every time to unlock the door, and it lacks a second form of authentication.

JG - The system proposed differs from the current systems by implementing voice recognition technology in order to make the system hands free. In almost all of the other solutions proposed, there is still a physical user input, normally through a PIN entered on the user’s smartphone. In order to accommodate those who might have difficulties with this, the proposed system is being designed to ensure that it is completely hands free and will not need physical input. This system may be designed around the concept of a home automation system, as explained in the source, "Android-based home door locks application via Bluetooth for disabled people". The article discusses how “it [Bluetooth] was seen as a simple, low cost and secure solution for wirelessly connecting a mobile device to a home automation system”[2]. The system being proposed can utilize some of the ideas from this source and others to ensure that the right balance of utility, usability, and security will be found.

MW - As many technologies are becoming more readily available to the public, various designs and implementations have arisen to make life easier. More specifically, an individual’s smartphone could run a multitude of applications, and these applications can easily control older and newer technologies remotely. Therefore, a smartphone can be utilized to control any or all aspects of a system, whether mechanical or electrical. In recent years, many designs and products have been developed for household automation. In the attempt to design such a remotely controlled system comprised of hands-free accessibility of a household door via an advanced smartphone-integrated door locking mechanism, it is necessary to understand the current technologies being used in such an area.

MW - In regard to a system capable of opening and closing a door via some external signal, very few such systems exist in residential/household environments. However, a garage door with

automatic open/close capabilities is a similar such system that is commonly used in residential applications. Many factors must be accounted for to understand the lack of such a system in other areas of a household, wherein it would appear useful. In a patent by Eccleston [9], some limitations pertaining to an automatic operator are as follows: “Many door operators are pneumatically, hydraulically, or electro-mechanically driven, and typically require substantial modification to the door, the doorframe, and indeed the structure wherein the door and doorframe are mounted. Installation of such an operator frequently requires a building permit and the services of a skilled professional technician installer. As a result, “do-it-yourself” installation is generally precluded. The resultant cost of permits, equipment, and labor often prevents handicapped individuals from purchasing door operators for use at home and at work. In addition, conventional door operators often are expensive to maintain” [9].

MW - Furthermore, Eccleston describes a remotely controllable operator system to be mounted to a door frame and a movable door to control positioning of the door. The system encompasses a motor assembly, linkage device, slip clutch assembly, and a remote-control interface [9]. While the system described would provide basic operation that E-Z Door seeks to provide, complete hands-free operation of the door would not be achieved. While maintaining remote operation of the door positioning, as well as, manual operation functionality; with various changes and critiques to a system such as Eccleston’s, it may prove to be a viable path for wirelessly controlling the position of a door.

MW - One system that was found that opens and closes residential doors - the Residential Automatic Door Opener, or RADO. [10] This is a prototype of a system that was designed to open a residential door in a way that is both simple and cheap. This is done using a pulley and mechanical arm system mounted to the side of the door. This system, when activated, opens the door automatically. In addition, the system has a built-in slip clutch system in order to let the system still function if the user was to manually move the door while the system is opening the door. This system is very much still in the design stages, but it seems to be a very cost-effective solution to the problem of an automatic door-opening system.

MW - Patents by Buzhardt [7], and Johnson [8] describe two implementations to remote door access. Although similarities exist between the proposed designs, a key difference occurs between the adaptation to an existing lock in a door. Buzhardt describes a design that is as follows: “A self-contained locking apparatus is disclosed which collects, stores, displays, and/or transmits information each time the apparatus is opened, closed or merely handled” [7]. Johnson’s design, on the other hand, involves the retrofitting of an existing door lock mechanism to enable user remote access [8]. To that extent, some consumers in the market for such products may have a preference for a device that does not require the modification of the current locking mechanism in the door. This may also be said for the designing of a new system, that it might be free from the limitations of the old mechanism.

MW - The implementations described in patents by Buzhardt and Johnson are useful to address design concerns such as security, functionality, and potential technologies. Johnson’s application involves a two-step locking or unlocking scenario in which two physical locks exist. For either lock to change current position, the user’s remote device while near the dwelling must accept input based on haptic or motion feedback [8]. This concept is no doubt a secure approach; however, if a theoretical hands-free system is desired, concerns arise from the necessary physical contact involved. A variant to Johnson’s design in which two locking mechanisms exist and proximity detection involving Bluetooth might prove suitable. While Buzhardt’s approach is not too concerned with security, the specific functionalities presented are intriguing. Buzhardt’s approach involves a system able to log various sets of data such as event date, time of access, location of user, and picture or video identification [7]. Buzhardt’s design also uses a smartphone to interface with the lock and hardware, which includes but is not limited to: a sensor, an event counter, a clock, a GPS, memory, a processor, a display, RFID, and a manual control panel [7].

1.4. Marketing Requirements

1. The system will provide hands free opening of the door.
2. The system will have multiple levels of security.
3. The system will open/close remotely while user is inside their residence.
4. The system will prevent unauthorized access.
5. The system will only allow specific users to open the door.

-BB

2. Engineering Analysis

CD- The following section is organized to look closer at each engineering requirement, and to provide analysis as to why it is needed for this project and how it was decided upon. In addition, there are sections placed in relevant places to discuss in further detail the different broad subsystems of the project, such as power supply research, communication, or motor choice and specifications.

2.1. Electromechanics

CD, MW- After conducting research on the weights of the typical front door of a house, the average front door of a house (80 inches by 36 inches, 1 ¾ inches thick) is around 80 pounds. The center of mass is 40 inches off the ground, 19 inches from the edge.

When the arm of the mechanism rotates 90 degrees, the door opens approximately 90 degrees as well.

The moment of inertia of a door about its hinges is as follows:

Equation 2.1.1:

$$I = (m * w^2) / 3$$

$$I = (\text{mass} * (\text{width of door})^2) / 3$$

$$I = (36\text{kg} * (.96\text{meters})^2) / 3$$

$$I = 11.05 \text{ m}^2 \cdot \text{kg}$$

In order to find the required amount of torque to open the door, some assumptions are made. To allow for some amount of losses due to friction on the hinges, and air resistance, it is assumed to have the door open 90 degrees in approximately 5 seconds. With this, angular acceleration may be calculated as follows:

Equation 2.1.2:

$$\alpha = (\omega_2 - \omega_1) / (t_2 - t_1)$$

$$\alpha = (\text{final angular velocity} - \text{initial angular velocity}) / (\text{final time} - \text{initial time})$$

$$\alpha = (.314 \text{ rad/sec} - 0 \text{ rad/sec}) / (5 \text{ sec} - 0 \text{ sec})$$

$$\alpha = 0.0628 \text{ rad} / \text{sec}^2$$

Required torque is calculated as follows:

Equation 2.1.3:

$$\mathcal{T} = I * \alpha$$

$$\mathcal{T} = \text{moment of inertia} * \text{angular acceleration}$$

$$T = 11.05 \text{ kg} \cdot \text{m}^2 \cdot 0.0628 \text{ rad} / \text{sec}^2$$

$$T = 0.6939 \text{ N} \cdot \text{m}$$

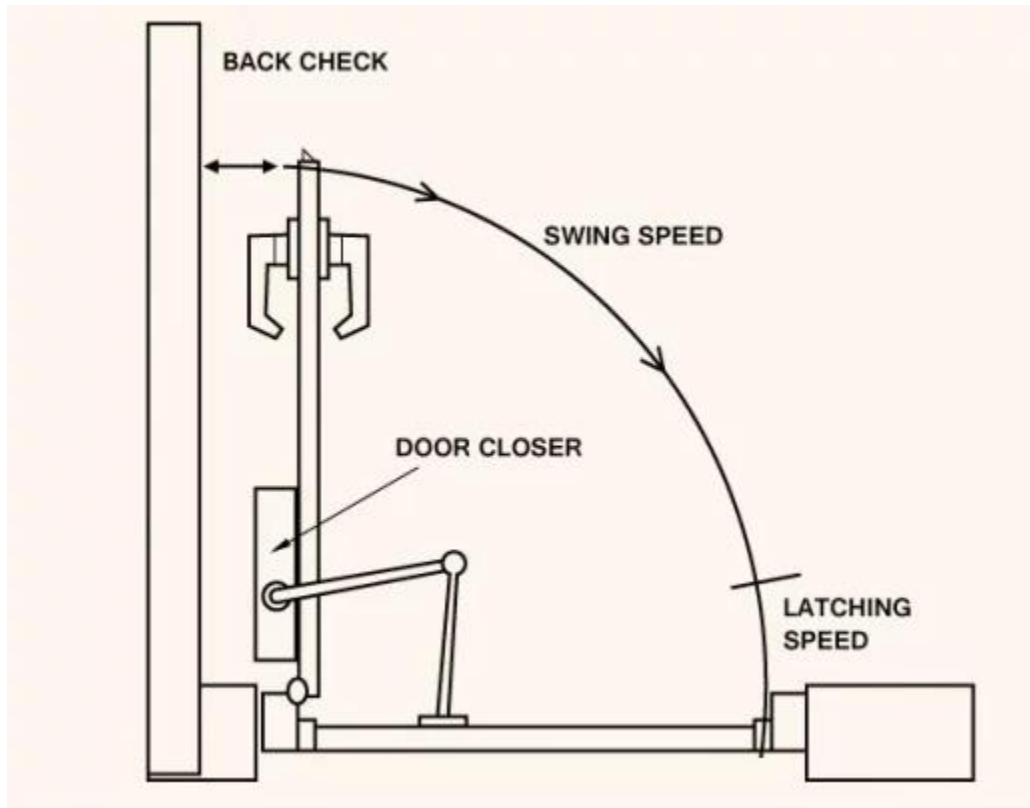

Figure 2: Door Opening Diagram

MW- Some considerations have been made in regard to the mechanism that will open and close a door. For any e-motor providing the necessary torque to open the door, the following criteria must be met; Motor and gearing must be sized to produce at least 1 Nm of torque, the motor must be reliable, the motor must be efficient, and finally, the motor must allow for control of speed and direction.

Many types of e-motors are available; however, one type must be selected to meet the needs of the system. A brushless DC motor (BLDC) may prove beneficial in this application. BLDC

motors are generally reliable, highly efficient / high output power to size ratio, and smaller form factor with higher speed ranges and lower electronic noise generation. As far specific selection of the motor is concerned, pricing is often the determining factor. It is typically expensive and outside the budget of the project to obtain a motor capable of more than 1 Nm of torque.

Control of a BLDC generally requires a driver circuit, and rotor position feedback. The driving circuit typically consists of some serial interface, pulse width modulation and MOSFETs to control the speed, position and direction of the rotor. Several options are available for rotor position feedback, most often encoder or hall effect sensors are used, however, sensorless systems are growing as well. Sensorless control is computationally heavy, therefore, if used in this system, a larger processor may be necessary.

For reasons due generally to the scope of this project, the decision is made to seek other motor options for the opening and closing of the door. For the complexity of control for a BLDC motor outweighs the need in this application. Therefore, other options are considered.

BB- After further research and analysis a servo motor has been chosen rather than a BLDC motor. Furthermore, the output shaft of the servo can be moved to an angle, position and velocity that a BLDC motor, without an added driver circuit and position feedback, cannot achieve. Also, the servo motor utilizes gearing coupled to a relatively small DC motor that allows for greater output torque compared to the DC motor operating alone.

MW- The servo motor is selected by first realizing the characteristics that need to be satisfied. While supplying ample torque, the servo should have more simplistic control than a BLDC motor, and provide feedback such as rotor speed and position. All of which are crucial to the system. The feedback is necessary in order to roughly sense the current that the motor is pulling from the power supply. If the door were to be obstructed upon opening, and the motor achieves maximum load, then the maximum current available will be pulled by the motor for the duration of obstruction. Without any feedback from the servo, the motor could potentially continue to pull current until the system is overwhelmed and fails.

2.2. Power

BB - The systems power supply will need to provide power to four main components, the microcontroller, opening/closing mechanism, locking mechanism and the backup power supply. The microcontroller that will be used in this design will be the Explorer 16/32 Developer Board which can be powered one of two ways, by external 9Vdc supply or USB power. The motor for the open/closing mechanism, as stated earlier will be a 12Vdc BLDC motor that will draw no more than 15A. As for the locking mechanism the exact design has not yet been determined but will need power for a small actuator to lock and unlock the modified deadbolt. From the power needs discussed above a 12Vdc power supply with an input of 120Vac 60Hz will be needed to supply the desired components. Also, as for the backup power supply, it will need to be properly sized to provide power to the locking mechanism and microcontroller for at least 24 hours. Once specific hardware is determined further power analysis for the system can be conducted.

2.3. Embedded Systems & Communications

According to a research paper by the International Journal of Science in 2016, the effective range of a HC-05 Bluetooth module is around 10 meters.

Another variable to consider is that the Bluetooth modules take a significant amount of time to connect - for example, according to reporting by users, the HC-05 module normally takes between 1 and 2 seconds to connect reliably once the devices enter the range.

Combining these two facts, a reasonable range to expect from the system would be that the Bluetooth module would connect successfully before coming within 5 meters of the door. This would give the module time to connect, even if someone were to drive up or walk up reasonably fast to the door.

User Interface

Once the successful connection has been made between the user's phone and the door system, serial communication between a phone application and the system should be straightforward to create and configure. This is all contingent on the connection between the phone and the Bluetooth module of the system.

Communications

CD- The decision to include two factors of authentication has been the main distinction between the E-Z Door system design and the existing systems on the market. As shown in the background research section, all the systems found while researching have only had one factor of authentication. To set the E-Z Door system apart, and to ensure that the system was very hard to hack or set apart, the decision for two factors was made. When deciding which two factors of authentication, they had to be hands free. This limited the choices to sound or wireless communication protocols. By examining the different wireless protocols out there, it was seen that RFID would be convenient, but the range was too limited, with a maximum range of 18 inches. The design tradeoffs between Wi-Fi, Bluetooth, and Zigbee are shown in the figure below, as seen from a paper published in 2012 on the benefits of Zigbee compared to the other two. [11]

	ZigBee	Wi-Fi	Bluetooth
Range	10-100 meters	50-100 meters	10 – 100 meters
Networking Topology	Ad-hoc, peer to peer, star, or mesh	Point to hub	Ad-hoc, very small networks
Operating Frequency	868 MHz (Europe) 900-928 MHz (NA), 2.4 GHz (worldwide)	2.4 and 5 GHz	2.4 GHz
Complexity (Device and application impact)	Low	High	High
Power Consumption (Battery option and life)	Very low (low power is a design goal)	High	Medium
Security	128 AES plus application layer security		64 and 128 bit encryption
Typical Applications	Industrial control and monitoring, sensor networks, building automation, home control and automation, toys, games	Wireless LAN connectivity, broadband Internet access	Wireless connectivity between devices such as phones, PDA, laptops, headsets

Table 1: Wireless Communications

The decision to choose Bluetooth was a combination of the above design tradeoffs, as well as the ability to natively connect to a phone through Bluetooth.

The other factor of authentication was chosen to be a voice input, as it is totally independent of the Bluetooth method of input. This means that even if someone had access to the phone, they still wouldn't be able to gain access into the house without the voice password. The design choice of how to compare the voice input with the password still needs to be made, but the choices have been talked through. There could be an open-source library downloaded to convert the voice input to a string, or the voice input could be compared to the correct password using some technique like autocorrelation.

Battery Backup

BB- System security and stability are two of the most important design parameters for the EZ Door. Furthermore, the system will be controlling the locking/unlocking and opening/closing of the user's home entrance, thus if loss of power occurs the system should still be secure and operate as designed. Specific design choices were analyzed in order to determine what portions of the systems will be provided power by the uninterruptible power supply (UPS) and for how long. Due to budget constraints the open/close electromechanical portion of the system will not be supplied by the UPS when loss of power occurs. The locking mechanism and microcontroller will be powered by the UPS for approximately 24 hours. These portions of the system were chosen because of their low power consumption. Therefore, allowing the milli-amp-hours provided by the UPS to be lower and consequently the price of the UPS to be cheaper.

Operates During Power Outage

CD- This requirement is an important factor to consider when implementing an electrical replacement for a system which is normally mechanical. There should be a backup whereby the owner of the house can gain access to the house, even if all power is out and the backup power supply is depleted. This can be accomplished by maintaining the use of a manual key within the new electronic locking mechanism.

Security

CD- When using communications and electronics, there is an inherent risk of a breach of security. If there was just one level of authentication (Bluetooth on the user's phone, for example), if someone had access to the homeowner's phone, the door would open for whoever had the phone. This is a problem for security in the system. In order to resolve this, the system must have at least two factors of authentication. For the design of the E-Z Door system, the two

factors of authentication are a Bluetooth input as the first level of authentication, and a voice password input as the second level of authentication.

BB- With security and system integrity being an integral part of this design, access to components from outside the residence is a topic of great concern. In order for the system to perform as desired for an extended period of time, it is important that the location of the mechanical portion of the opening mechanism must be located on the inner side of the door. If it was located on the outside of the door, the system could be easily tampered with and even compromised, allowing unauthorized access to the user's home.

2.4 Digital Signal Processing

[JG] The voice recognition module of the project uses digital signal processing in order to recognize passwords from human speech. Different algorithms were considered that can be broken down into two categories, speech-to-text and auto-correlation.

Speech-to-text can utilize a range of DSP algorithms such as “Fast Fourier Transform” or “Hidden Markov Model” to convert human speech into a corresponding string of text.

Auto-correlation is another technique that utilizes DSP algorithms to essentially compare the waveform of the set password to another user’s password waveform and accepts the user’s password if it is within a certain margin of error of the original password waveform.

Speech-to-text is preferred given that auto-correlation would need a relatively low margin of error set in the waveform if you want multiple people to be able to use the password. Two different people can say the same password and still produce different waveforms and a low margin of error for the speech recognition takes away from the system’s secure nature. A mix of a DSP algorithm as well as a machine learning algorithm is the most secure option for the speech recognition module.

3. Design Requirements Specification

3.1. Engineering Requirements

Marketing Requirements	Engineering Requirements	Justification
1	1. Opening mechanism will provide a minimum of 1 Nm of torque.	A certain threshold of force will need to be applied to the door to open it.
1	2. The system will require approximately 5 seconds to open, 5 seconds to close, and allow user to configure the length of time the door is open.	This would give the motor time to open the door with room for error, while still being reasonably fast.
3	3. The system will be powered by typical 120Vac 60Hz outlet.	Allows for easy household installation and testing.
2, 3, 4, 5	4. Wireless communication should connect within 5 meters.	Allows for latency time during connection, with regards to the ranges of the two modules.
4, 5	5. Phone Application which successfully connects to the system, and acts as a UI.	Once a successful connection has been made, the app must control the system easily.
2, 4	6. Battery backup will provide power for 24 hours to the locking mechanism and microcontroller.	If power loss occurs system should still allow authorized user access to the house.
4, 5	7. Deadbolt will be able to be mechanically operated with loss of power.	Will still allow for the system user to actuate the lock in case of complete power loss.
2, 5	8. The system will have at least two factors of authentication.	The system must provide additional security when compared to a typical lock.
4	9. Mechanical portion of the system will not be accessible from outside the door.	Prevents the system from being tampered with and increases the security of the system.

Table 2: Engineering Requirements

CD, BB, JG, MW

4. Engineering Standards Specification

Communication

Universal Serial Bus (USB)

Bluetooth

IEEE 802.11

RS-232

Programming Languages

Bash

C (Embedded)

Python

Connector Standards

USB

5. Accepted Technical Design

5.1 Hardware Design

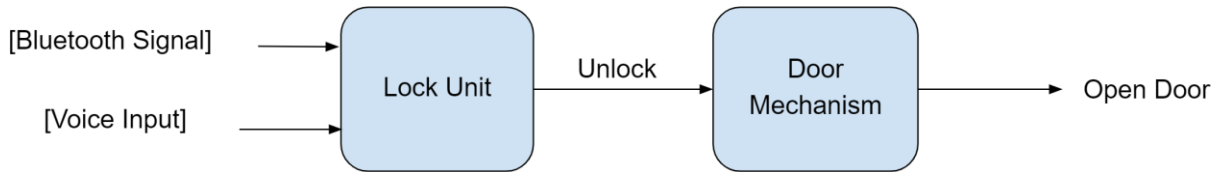

Figure 3: Hardware Block Diagram - Level 0

-JG

CD- The very high-level view of the E-Z Door system includes two factor authentications as the input to the system, and the door opening as the output. This is done using two different blocks - the locking unit and the door opening mechanism.

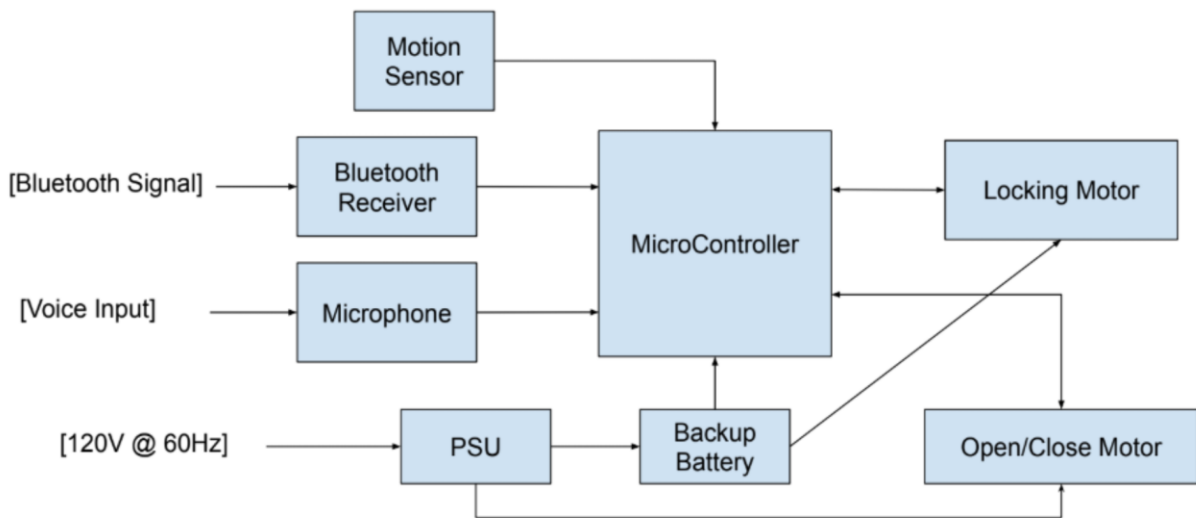

Figure 4: Hardware Block Diagram - Level 1

-MW

CD- Looking at the level 1 block diagram, it can be seen through comparison with the level 0 diagram that there are additional inputs to the system. This includes the motion sensor and the

power supply. The motion sensor adds the assurance that the door will not open if there are any disturbances in the path of the door. The next addition to the inputs, the power supply, is also necessary for us to keep in mind when it comes to design, especially as the system is to be able to run on battery power for a minimum of 24 hours.

<i>Module</i>	Bluetooth Receiver
<i>Inputs</i>	<ul style="list-style-type: none"> - Bluetooth Signal - Power: 3.3V DC
<i>Outputs</i>	<ul style="list-style-type: none"> - Connection / Authentication Status
<i>Functionality</i>	Provides a secure form of communication with the user's phone, used as an authentication factor.

Table 3: Bluetooth Receiver Functional Requirement

-MW

<i>Module</i>	Microphone
<i>Inputs</i>	<ul style="list-style-type: none"> - User's Voice - Power: 3.3V DC
<i>Outputs</i>	<ul style="list-style-type: none"> - User's Voice as an Audio Signal
<i>Functionality</i>	Takes in the user's voice as the password for the second form of authentication.

Table 4: Microphone Functional Requirement

-MW

<i>Module</i>	Power Supply Unit
<i>Inputs</i>	<ul style="list-style-type: none"> - Power: 120Vac at 60Hz
<i>Outputs</i>	<ul style="list-style-type: none"> - Power: 12V, 5V, 6V DC
<i>Functionality</i>	Steps down the input power to charge a battery and supply sub-components.

Table 5: Power Supply Functional Requirement

-MW

<i>Module</i>	Backup Battery
<i>Inputs</i>	- Power: DC from PSU for charging
<i>Outputs</i>	- 5V DC, 500mA
<i>Functionality</i>	If main power to the system is lost, the battery will supply enough charge for the microcontroller and lock/unlock mechanism to function for at least 24 hours.

Table 6: Battery Backup Functional Requirement

-MW

<i>Module</i>	Lock/Unlock Solenoid
<i>Inputs</i>	- Power: 12V DC, 212mA - Actuate Control Signal
<i>Outputs</i>	- Lock/unlock position
<i>Functionality</i>	The microcontroller will change the solenoid position based on the lock/unlock state of the system.

Table 7: Lock/Unlock Functional Requirement

-MW

<i>Module</i>	Open/Close Servo Motor
<i>Inputs</i>	- Power: 6V DC, 4 Amperes - One PWM Control Signal
<i>Outputs</i>	- Torque - Rotor speed/position feedback signal
<i>Functionality</i>	The microcontroller will change the motor position based on the open/close state of the system.

Table 8: Open/Close Servo Functional Requirement

-MW

<i>Module</i>	Microcontroller (Explorer 16)
<i>Inputs</i>	<ul style="list-style-type: none"> - Power: 5V DC - Bluetooth - Audio Signal - Open/Close State - Lock/Unlock State
<i>Outputs</i>	<ul style="list-style-type: none"> - Lock/Unlock Door Signal - Open/Close Door Signal
<i>Functionality</i>	Handles all the inputs/outputs, authentication, processing, and the states of the overall system.

Table 9: Microcontroller Functional Requirement

-MW

Hardware Selection

MW - In order to select a layout and physical hardware for the system, overall functionality and operating conditions are reconsidered. In general, three major hardware systems are required.

The first being a control sub-system. This sub-system currently comprises the Explorer 16 board and its subsystems including Bluetooth and a microphone. For simplicity, a possible second microcontroller for signal processing is included into the control system. The main consideration for these components is power. If 120VAC at 60Hz is available, something needs to happen for the control system to be powered sufficiently. The first step is to invert and regulate the incoming power to 12VDC with a max of 7 amps of current. This may easily be achieved with a standard wall adapter typically used for charging laptops. Using this approach, the Explorer board may be powered directly. For the possible signal processing board, a raspberry pi is a reasonable consideration. Powering such a board requires a minimum of 4.5VDC and upwards of

3 Amps of current. To account for this, a DC/DC buck converter is used to regulate to 5VDC with enough current.

The second subsystem to consider is the locking/unlocking mechanism. For this, a solenoid that mounts to the inner door frame is selected. Such a mechanism allows for existing door handles/locks to be used. This reduces installation time and cost. The selected solenoid also conveniently requires 12VDC and only a 212mA of current, therefore power may be supplied indirectly through the wall adapter. However, a switching component is required to change the position of the solenoid via software. Using an n-channel MOSFET, along with some passive components the switching of the solenoid is achieved.

The third subsystem comprises the necessary hardware to open and close the door. It is determined that a servo motor capable of approximately 3.5 Nm of torque will be used. The torque specification requires the motor to be supplied with a minimum of 4 Amps at 6VDC. This is accomplished by using another buck converter to regulate the incoming supply. Figure 5. depicts a schematic for the board that provides power to the subsystems.

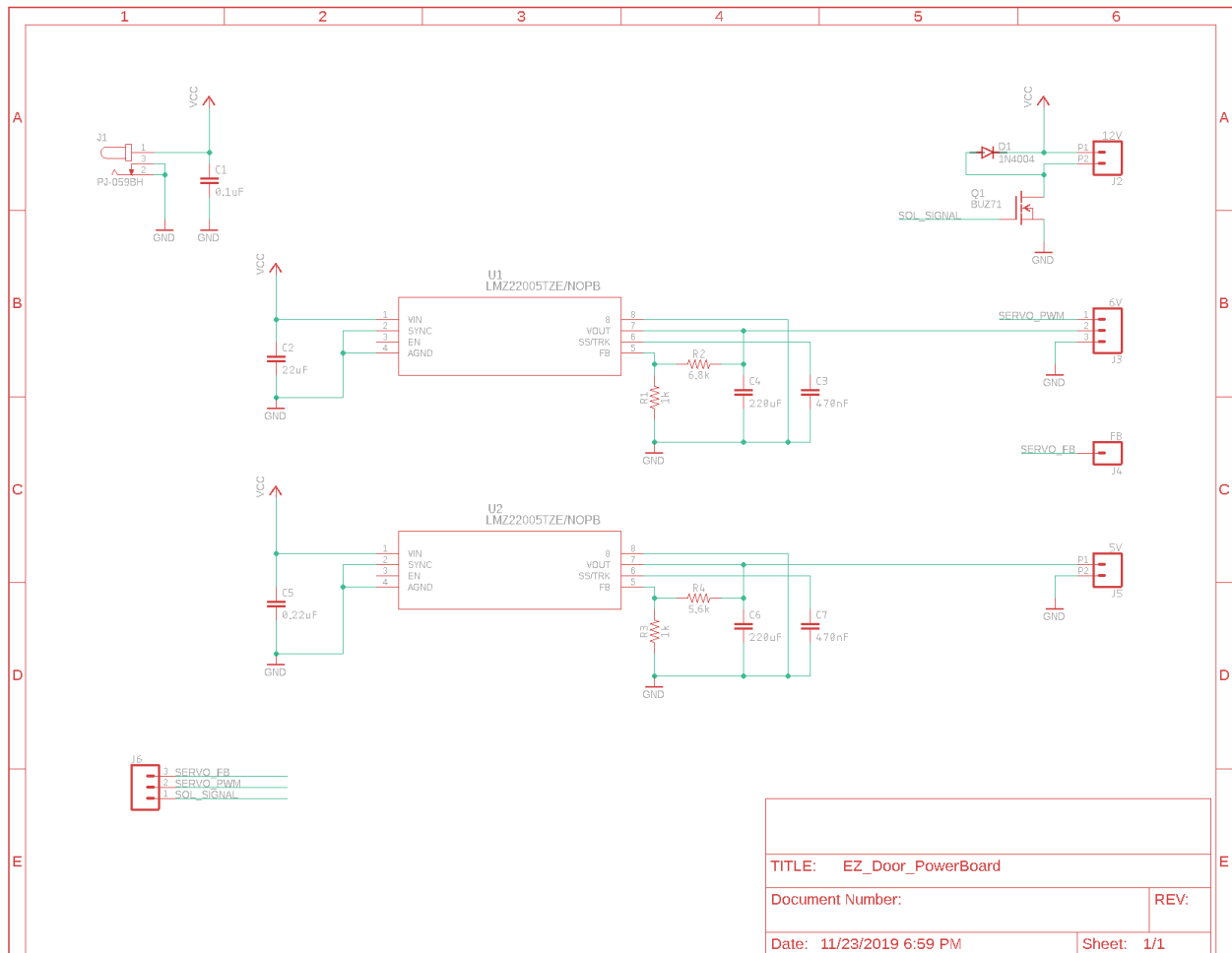

Figure 5: Power Supply Schematic

JG - The fourth subsystem is the voice recognition module, which contains a microphone/pre-amplifier circuit. It is wired up to the ADC on the dsPIC33, which in turn transmits the voice signal values to either a Raspberry Pi via a wired UART communication channel, or possibly a server via UART.

The microphone/pre-amplifier circuit, as well as the raspberry pi, are powered on a 5V rail.

A range of digital signal processing algorithms have been discussed though they can be broken into two categories, speech-to-text and auto correlation.

Both options for digital signal processing are discussed in section 3.4.

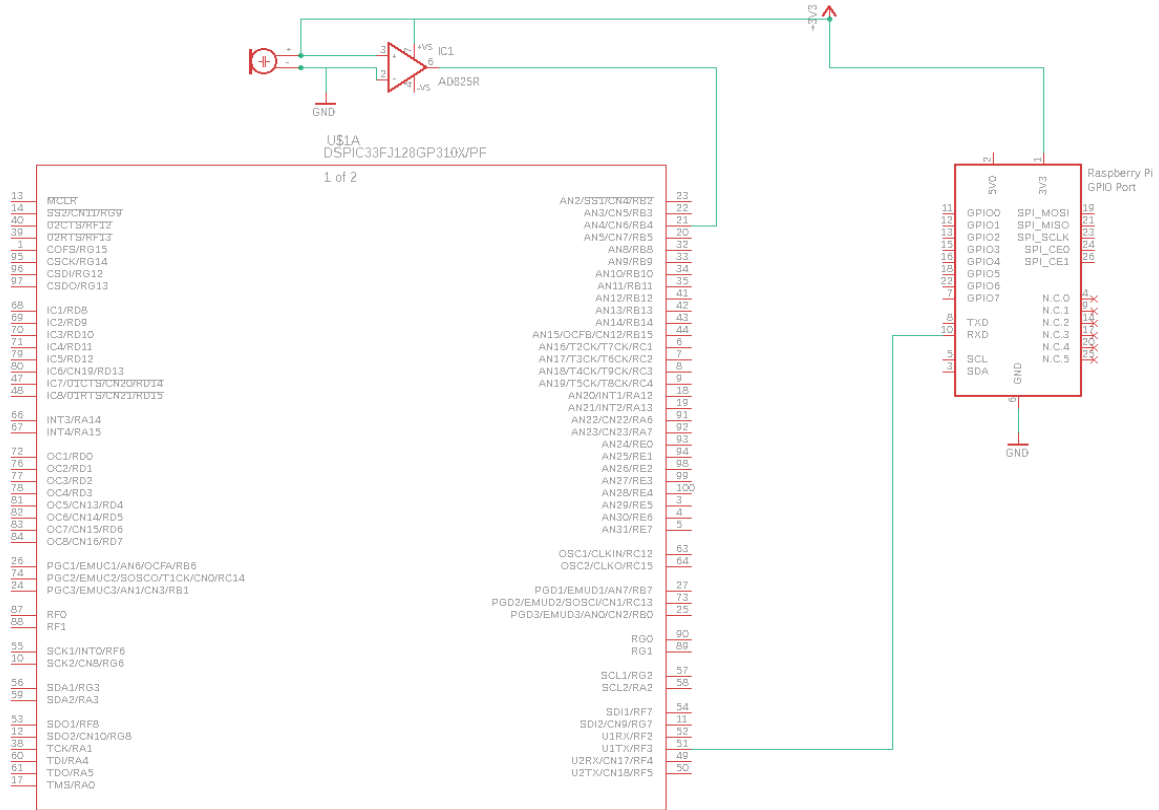

Figure 6: Voice Recognition Module Schematic

5.2. Software Design

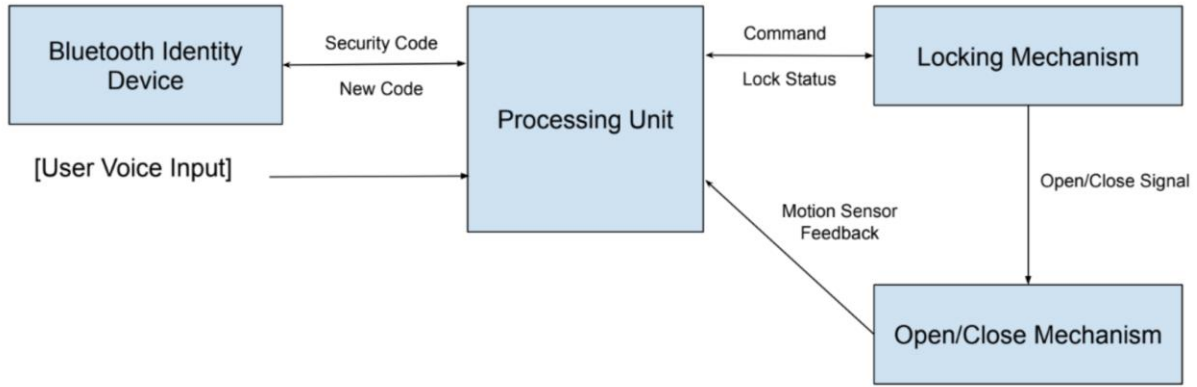

Figure 7: Software Block Diagram - Level 0

-MW

CD - The central processing unit of the system will be responsible for controlling the inputs and outputs of all the peripherals, as well as the internal calculations required to determine what to do with the incoming information to the system. It controls the locking mechanism, monitoring its state and sending it an electronic signal to lock or unlock. The CPU also controls the mechanical opening and closing of the door, and when/how fast it should do that.

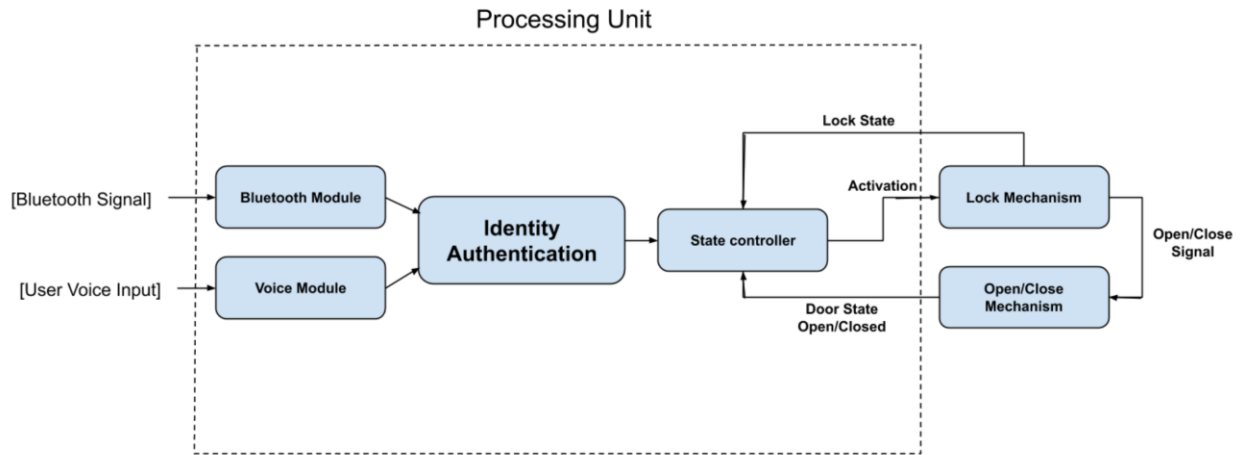

Figure 8: Software Block Diagram - Level 1

-JG

CD - At this level in the software design, there is more detail in how the controller makes decisions on when to lock, unlock, open, and close the door. It waits for the locking mechanism to unlock before sending the control signal to the door mechanism to open. In addition, the inputs to the system are more clearly identified as the methods of identity authentication which then send the green light to the state controller to unlock and open the door.

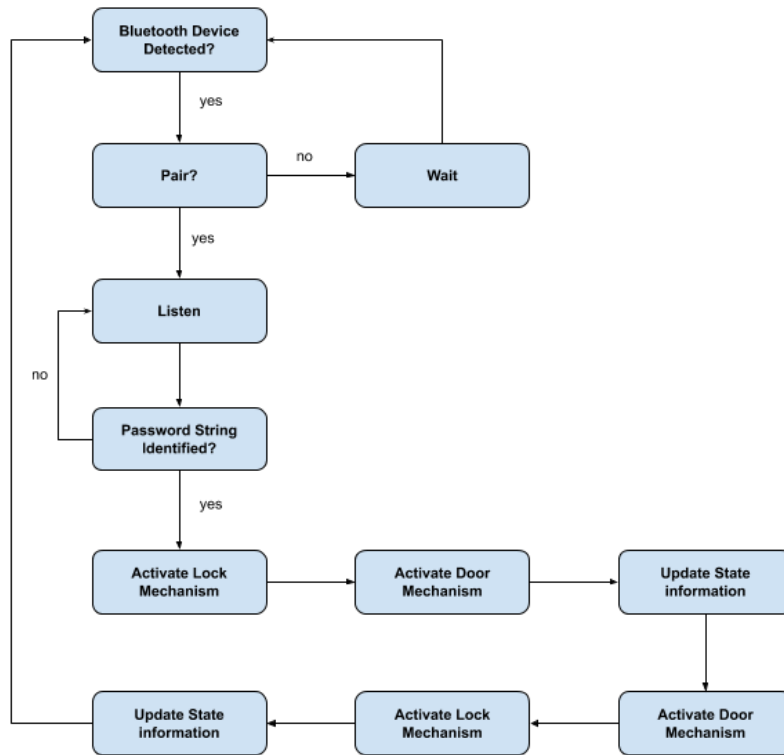

Figure 9: Software Block Diagram - Level 2

-JG

CD - This level 2 Software Block Diagram is when the real logic of the system can be seen.

There are two continuous loops in the system, with the two inputs - one with Bluetooth, and one with the microphone. If the system doesn't sense a recognized Bluetooth module to connect to, the system will never advance to the next stage of identification, voice input. Likewise, if the voice password is never recognized, the unlocking mechanism will never be activated. Once the door has been unlocked and opened, the system will then remain in an idle state for a configurable amount of time. After the amount of time allotted has passed, the system will then

close the door, activate the lock, disconnect the Bluetooth module, and resume normal operation for a different Bluetooth device.

Software Selection

The dsPIC33 chip is running Embedded C code, which is the backbone of this project. The C code for the dsPIC controls the following main parts of the E-Z Door system.

- Bluetooth Communication with the user's phone over UART
- 12-bit Analog-to-Digital Conversion (ADC) of microphone input data
- UART Serial communication with the Raspberry Pi
- Pulse Width Modulation (PWM) to control the servo motor

The dsPIC33 is configured to have an instruction clock cycle speed of 40MHz. The system is using two internal timers of the dsPIC33 to control 2 different functions - TMR1 is used as a millisecond delay function, and TMR3 is used to trigger sampling of the microphone data at a rate of 16KHz.

When the microphone data is sent over serial communication to be processed, there are multiple steps required to be able to analyze it. The data is first read into a file as a list of integers in C, then using a library in python the integers are scaled and converted into a .wav sound file. Once it is in a sound file, the deepspeech program is used to analyze the .wav file, and determine what words were spoken. Lastly, the data is then placed into a string of standardized length to send back to the dsPIC33 over UART to be displayed on the LCD and used for password verification.

All this code is used for the three steps of the system software. The first step is to verify the user's identity through the Bluetooth connection and voice password authentication. Second, the signal will be sent to activate the solenoid to unlock the door. Lastly, once the door has been unlocked, the PWM signal to control the servo motor will be sent to open the door.

The code used to implement this system is shown below, in the appropriate subsystem.

- **ADC Sampling subsystem**

To get the most possible information from the PIC board, 12-bit ADC sampling is used to get a maximum resolution of 0 - 4095. The sampling rate chosen is 16KHz, based on the fact that the program/algorithm used to interpret the data into speech requires that the data be converted into a .wav file with 16-bit integers at a rate of 16KHz. If the rate is chosen as 16KHz, then no audio conversion is necessary - the integers can be scaled and saved directly into a .wav file in the next subsystem.

C functions to initiate and use ADC with the microphone

```
#include "ADC.h"
#include <p33FJ256GP710.h>
int ReadADC(int ch) {
    AD1CHS0bits.CH0SA = ch; // 1. select analog input channel
    // start sampling, automatic conversion will follow
    AD1CON1bits.SAMP = 1; // 2. Start sampling.
    while (!AD1CON1bits.DONE); //5. wait for conversion to complete
    AD1CON1bits.DONE = 0; // 6. clear flag. We are responsible see text.
    return ADC1BUF0; // 7. read the conversion results
} // ReadADC

void InitADC(int amask) {
    AD1PCFGH = amask; // select analog input pins
    AD1CON1 = 0x00E0; // auto convert @ end of sampling, Integer Data out.
    // see Text pg. 179 & Sec. 17 on AD1CON1.
    AD1CON2 = 0; // use MUXA, AVssand AVddused as Vref
```

```

AD1CON3 = 0x1F01; // Tad = 2xTcy = 125ns. 31*Tad for conversion time.
AD1CSSL = 0; // no scanning required
AD1CON1bits.AD12B = 1;
AD1CON1bits.SSRC = 2;
T3CON = 0x8010;
PR3 = 312;
AD1CON1bits.ADON = 1; // Turn on the ADC
} // InitADC

```

- **C code to use LCD display for debugging and displaying**

```

#include "LCD.h"
#include <p33FJ256GP710.h>
#include "Timer.h"
#define LCDDATA 1
#define LCDCMD 0
#define PMDATA PMDIN1
#define RW LATDbits.LATD5 // LCD R/W signal
#define RS LATBbits.LATB15 // LCD RS signal
#define E LATDbits.LATD4 // LCD E signal
#define RW_TRIS TRISDbits.TRISD5
#define RS_TRIS TRISBbits.TRISB15
#define E_TRIS TRISDbits.TRISD4
#define busyLCD() readLCD( LCDCMD) & 0x80
#define addrLCD() readLCD( LCDCMD) & 0x7F
#define getLCD() readLCD( LCDDATA)
#define clockLCD() {E = 1; Nop();Nop();Nop();Nop();Nop();Nop();Nop();Nop();Nop();Nop();Nop();Nop(); E
= 0;}
#define putLCD( d) writeLCD( LCDDATA, (d))
#define cmdLCD( c) writeLCD( LCDCMD, (c))
#define homeLCD() writeLCD( LCDCMD, 2)
#define clrLCD() writeLCD( LCDCMD, 1)
#define setLCDG( a) writeLCD( LCDCMD, (a & 0x3F) | 0x40)
#define setL CDC( a) writeLCD( LCDCMD, (a & 0x7F) | 0x80)

void initLCD(void) {
// PMP initialization
PORTE = 0;
TRISE = 0xFF00;
RW = 0;
RS = 0;
E = 0;
RW_TRIS = 0;
RS_TRIS = 0;
E_TRIS = 0;

```



```

ms_delay(10);

//initiate the HD44780 display 8-bit init sequence
RS = LCDCMD; // command register
PORTE = 0b00111000; // 8-bit interface, 2 lines, 5x7
clockLCD();
ms_delay(10);

PORTE = 0b00001100; // display ON, cursor off, blink off
clockLCD();
ms_delay(10);

PORTE = 0b00000001; // clear display
clockLCD();
ms_delay(10);

PORTE = 0b00000110; // increment cursor, no shift
clockLCD();
ms_delay(10);
} // initLCD

char readLCD(int addr) {
    int dummy;
    TRISE = 0xffff;
    RS = addr; // select the command address
    RW = 1;
    clockLCD();
    dummy = PORTE;
    TRISE = 0;
    return ( (char) dummy); // read the status register

} // readLCD

void writeLCD(int addr, char c) {
    TRISE = 0xff00;
    ms_delay(2);
    RW = 0;
    RS = addr;
    PORTE = c;
    clockLCD();
    TRISE = 0xffff;
} // writeLCD

void putsLCD(char *s) {

```

```

    while (*s) putLCD(*s++);
} //putsLCD

```

- **C code to initiate and use UART communication**

```

#include "UART.h"
#include <p33FJ256GP710.h>

#define BRATE 22//11 for 921600//86 for 115200 baud//990 for 9600 baud // 9600 baud (BREGH=1)
#define U_ENABLE 0x8808 // enable the UART peripheral (BREGH=1)
#define U_TX 0x1400 // enable transmission
#define BACKSPACE 0x8 // ASCII backspace character code

void initUART(void) {
    U2BRG = BRATE;
    U2MODE = U_ENABLE;
    U2STA = U_TX;
    //TRISFbits.TRISF12 = 1; // make RTS output
    //RTS = 1; // set RTS default status
    //TRISFbits.TRISF13 = 0; // make RTS output
} // initUART

int putcharUART(int c) {
    //while (CTS); // wait for !CTS, clear to send
    while (U2STAbits.UTXBF); // wait while Tx buffer full
    U2TXREG = c;
    return c;
} // putcharUART

void putstringUART(char *s) {

    while (*s) // loop until *s == '\0' the end of the string

        putcharUART(*s++); // send the character and point to the next one
        putcharUART('\r'); // terminate with a cr / line feed
        putcharUART(0x0A);
} // putstringUART

// wait for a new character to arrive to the UART2 serial port

char getcharUART(void) {
    //RTS = 0; // assert Request To Send !RTS
    while (!U2STAbits.URXDA); // wait for a new character to arrive
    //RTS = 1;
    //printf("U2RXREG = %d\n\n", (int)U2RXREG);
}

```

```

//PORTA = U2RXREG;
//char temp = U2RXREG;
//putstringUART("Received: ");
//putcharUART(temp);
//putcharUART('\r');
return U2RXREG; // read the character from the receive buffer
} // getcharUART

```

```

char *getstringUART(char *s, int len) {
char *p = s; // copy the buffer pointer
do {
*s = getcharUART(); // wait for a new character
putcharUART(*s); // echo character
if ((*s == BACKSPACE)&&(s > p)) {
putcharUART(' '); // overwrite the last character
putcharUART(BACKSPACE);
len++;
s--; // back the pointer
continue;
}
if (*s == '\n') // line feed, ignore it
continue;
if (*s == '\r') // end of line, end loop
break;
s++; // increment buffer pointer
len--;
} while (len > 1); // until buffer full

*s = '\0'; // null terminate the string

return p; // return buffer pointer
} // getstringUART

```

- **Code to read in integers over serial UART communication**

The dsPIC33 handles the ADC sampling, but the processor on the PIC is not powerful enough to interpret that as sound. This must be done externally, and to do that, the data must be sent over serial communication. The following code reads in the incoming information, and outputs in into a text file with the name provided by the user upon running.

C code to read integers from serial communication

```
#include <stdio.h>
#include <string.h>

#define max 16000
int i;
int nums[max];

int main(int argc, char *argv[])
{
FILE *fp;
fp = fopen(argv[1], "w");
int i = 0;
while (i < max)
    {
scanf("%d", &nums[i]);
i++;
}
i = 0;
while (i < max)
    {
fprintf(fp, "%d\n", nums[i]);
i++;
}
int fclose( FILE *fp );
}
```

- **Python to create .wav file**

The integers are read into a text file using C, but now these integers must be converted into a file that can be interpreted as audio. This is done using python, and two libraries in python – numpy and scipy. These two libraries combined have the functions to convert the integers into a format that can be read as a .wav file.

Python code to convert string of integers into a .wav file

```
import numpy as np
import scipy.io.wavfile
import math
import sys
data2 = []
def read_integers(filename):
    with open(filename) as f:
        return [int(int(x) - 2024)*16 for x in f]

data2 = read_integers(sys.argv[1])
```

```
rate = 10000
k = 0;
data = np.array(data2).astype('int16')
scipy.io.wavfile.write(sys.argv[2],rate,data)
```

- **Combining all of the functions into a complete system, running continuously**

To get all of these functions and programs to run without prompting, a powerful program must be used to run all of the programs in succession. This is accomplished using a bash script – it can have an infinite loop that reads in the samples, converts it into a .wav file, and analyzes that file.

Bash script to compile and run C code, Python code, and deepspeech program in an infinite while loop, and send the speech recognition output back to the dsPIC33

```
#!/bin/bash
while true; do
    gcc -o go ReadInIntsFromPIC.c
    sudo ./go < /dev/ttyACM0 in.log
    python CreateWavIntsFromInts.py in.log Downloads/speech/audio/1.wav
    deepspeech --model Downloads/speech/deepspeech-0.5.1-models/output_graph.pbmm --alphabet
Downloads/speech/deepspeech-0.5.1-models/alphabet.txt --lm Downloads/speech/deepspeech-0.5.1-
models/lm.binary --trie Downloads/speech/deepspeech-0.5.1-models/trie --audio
Downloads/speech/audio/1.wav > output.log
    gcc -o o Output.c
    ./o > /dev/ttyACM0 output.log
Done
```

- **Servo Motor Subsystem**

The Servo motor system is controlled via Pulse Width Modulation. A demonstration of PWM was created in order to show that the Explorer board is capable of controlling a motor – this code will need to be modified in order to control the specific servo motor chosen.

6. Mechanical Sketch

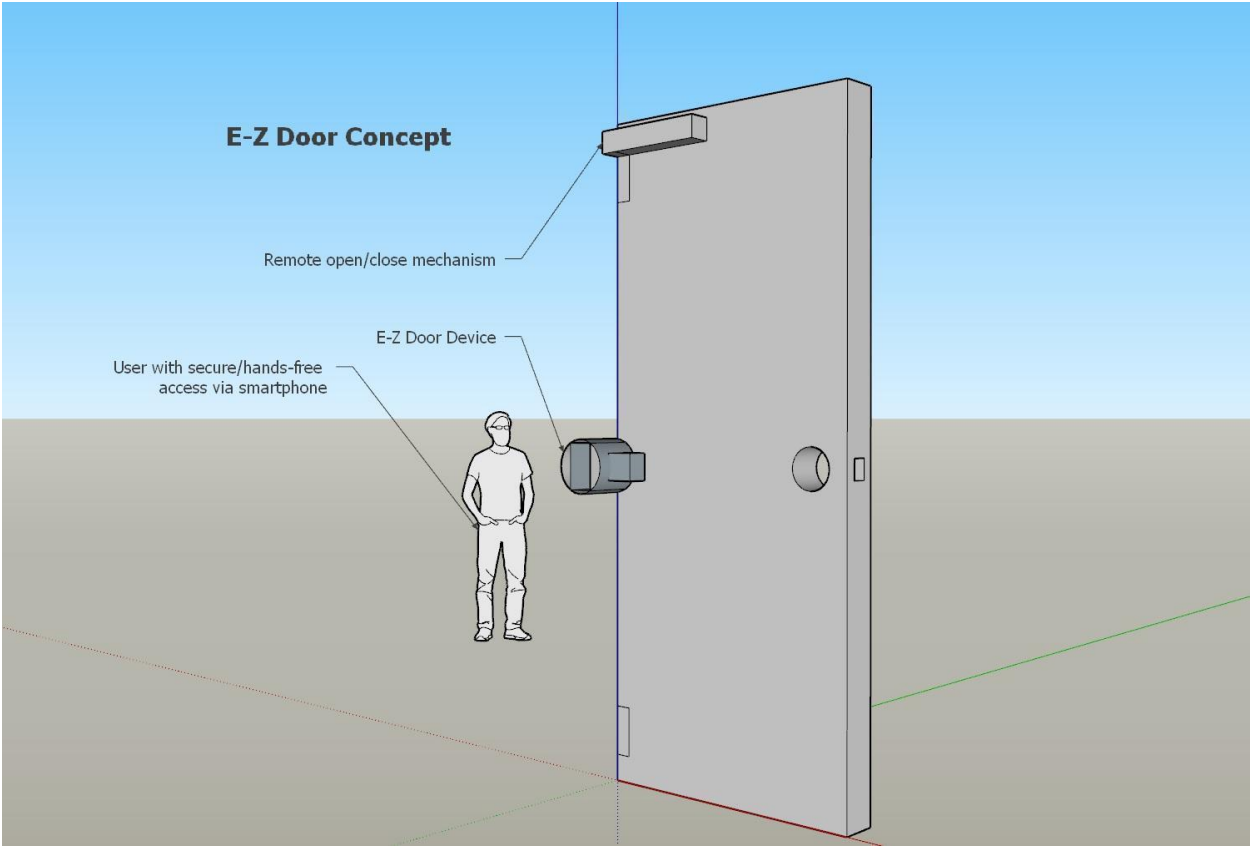

Figure 10: Mechanical Sketch

-MW

7. Team Information

There are 4 main sections of work that need to be accomplished to successfully complete this project. The 4 sections are: Electronics, Communications, Electromechanics, and Embedded Systems.

The 4 sections will each have two people assigned to it, a primary and a secondary, although all members will also aid the others in the project, and the roles may change in the future.

- **Electronics**
 - *Primary: Mitch Wilson*
 - *Secondary: Brice Brenneman*
- **Communications**
 - *Primary: Justin Gnatiuk*
 - *Secondary: Caleb Dyck*
- **Electromechanics**
 - *Primary: Brice Brenneman*
 - *Secondary: Mitch Wilson*
- **Embedded Systems**
 - *Primary: Caleb Dyck*
 - *Secondary: Justin Gnatiuk*

8. Parts List

8.1 Accepted Technical Design Parts List

Qty	Ref Des	Part Number	Description
1	C1		0.1uF Capacitor
1	C2		22uF Capacitor
2	C3, C7		470nF Capacitor
1	C4, C6		220uF Capacitor
1	C5		0.22uF Capacitor
2	R1, R3		1k Ω Resistor
1	R2		6.8k Ω Resistor
1	R4		5.6k Ω Resistor
1	D1	1N4004	Diode
1	Q1	BUZ71	N-Channel Power MOSFET
1	J1	PJ-059BH	CONN PWR JACK 2.5X5.5MM SOLDER
2	U1, U2	LMZ22005TZE/NOPB	DC/DC Converter

Table 10: Parts List

9. Project Schedule

1	SDP I 2019				
2	Project Design	88.38 days	Fri 8/30/19	Tue 11/26/19	Brice Brenneman, Caleb Dyck, Justin Gnatiuk, Mitch Wilson
3	Midterm Report	39.38 days	Fri 8/30/19	Tue 10/8/19	Brice Brenneman, Mitch Wilson, Caleb Dyck, Justin Gnatiuk
4	Cover page	39.38 days	Fri 8/30/19	Tue 10/8/19	Brice Brenneman, Caleb Dyck, Mitch Wilson
5	T of C, L of T, L of F	39.38 days	Fri 8/30/19	Tue 10/8/19	Caleb Dyck, Mitch Wilson
6	Problem Statement	39.38 days	Fri 8/30/19	Tue 10/8/19	Brice Brenneman, Caleb Dyck, Justin Gnatiuk, Mitch Wilson
7	Need	39.38 days	Fri 8/30/19	Tue 10/8/19	Caleb Dyck
8	Objective	39.38 days	Fri 8/30/19	Tue 10/8/19	Brice Brenneman
9	Background	39.38 days	Fri 8/30/19	Tue 10/8/19	Brice Brenneman, Caleb Dyck, Justin Gnatiuk, Mitch Wilson
10	Marketing Requirements	39.38 days	Fri 8/30/19	Tue 10/8/19	Brice Brenneman
11	Engineering Requirements Specification	39.38 days	Fri 8/30/19	Tue 10/8/19	Brice Brenneman, Caleb Dyck, Mitch Wilson
12	Engineering Analysis	39.38 days	Fri 8/30/19	Tue 10/8/19	Brice Brenneman, Caleb Dyck, Justin Gnatiuk, Mitch Wilson
13	Circuits (DC, AC, Power, ...)	39.38 days	Fri 8/30/19	Tue 10/8/19	Brice Brenneman, Mitch Wilson
14	Electronics (analog and digital)	39.38 days	Fri 8/30/19	Tue 10/8/19	Brice Brenneman, Mitch Wilson
15	Signal Processing	39.38 days	Fri 8/30/19	Tue 10/8/19	Caleb Dyck, Justin Gnatiuk
16	Communications (analog and digital)	39.38 days	Fri 8/30/19	Tue 10/8/19	Caleb Dyck, Justin Gnatiuk
17	Electromechanics	39.38 days	Fri 8/30/19	Tue 10/8/19	Brice Brenneman, Mitch Wilson
18	Computer Networks	39.38 days	Fri 8/30/19	Tue 10/8/19	Caleb Dyck, Justin Gnatiuk
19	Embedded Systems	39.38 days	Fri 8/30/19	Tue 10/8/19	Caleb Dyck
20	Accepted Technical Design	39.38 days	Fri 8/30/19	Tue 10/8/19	Caleb Dyck, Justin Gnatiuk, Mitch Wilson, Brice Brenneman
21	Hardware Design: Phase 1	39.38 days	Fri 8/30/19	Tue 10/8/19	Caleb Dyck, Justin Gnatiuk, Mitch Wilson, Brice Brenneman
22	Hardware Block Diagrams Levels 0 thru N (w/ FR tables)	39.38 days	Fri 8/30/19	Tue 10/8/19	Mitch Wilson, Brice Brenneman
23	Software Design: Phase 1	39.38 days	Fri 8/30/19	Tue 10/8/19	Caleb Dyck, Justin Gnatiuk, Mitch Wilson
24	Software Behavior Models Levels 0 thru N (w/FR tables)	39.38 days	Fri 8/30/19	Tue 10/8/19	Caleb Dyck, Justin Gnatiuk, Mitch Wilson
25	Mechanical Sketch	39.38 days	Fri 8/30/19	Tue 10/8/19	Mitch Wilson
26	Team information	39.38 days	Fri 8/30/19	Tue 10/8/19	Caleb Dyck
27	Project Schedules	39.38 days	Fri 8/30/19	Tue 10/8/19	Caleb Dyck, Justin Gnatiuk
28	Midterm Design Gantt Chart	39.38 days	Fri 8/30/19	Tue 10/8/19	Caleb Dyck, Justin Gnatiuk
29	References	39.38 days	Fri 8/30/19	Tue 10/8/19	Brice Brenneman, Caleb Dyck, Justin Gnatiuk, Mitch Wilson
30	Midterm Parts Request Form	39.38 days	Fri 8/30/19	Tue 10/8/19	Brice Brenneman, Mitch Wilson
31	Preliminary Design Presentations	0 days	Thu 9/19/19	Thu 9/19/19	Brice Brenneman, Caleb Dyck, Justin Gnatiuk, Mitch Wilson
32	Project Poster	12.38 days	Thu 10/10/19	Tue 10/22/19	Brice Brenneman, Caleb Dyck, Justin Gnatiuk, Mitch Wilson
33	Final Design Report	47.38 days	Thu 10/10/19	Tue 11/26/19	Brice Brenneman, Caleb Dyck, Justin Gnatiuk, Mitch Wilson
34	Abstract	47.38 days	Thu 10/10/19	Tue 11/26/19	Caleb Dyck
35	Hardware Design: Phase 2	47.38 days	Thu 10/10/19	Tue 11/26/19	Brice Brenneman, Mitch Wilson
36	Modules 1...n	47.38 days	Thu 10/10/19	Tue 11/26/19	Brice Brenneman, Mitch Wilson
37	Simulations	47.38 days	Thu 10/10/19	Tue 11/26/19	Brice Brenneman, Mitch Wilson
38	Schematics	47.38 days	Thu 10/10/19	Tue 11/26/19	Brice Brenneman, Mitch Wilson
39	Software Design: Phase 2	47.38 days	Thu 10/10/19	Tue 11/26/19	Caleb Dyck, Justin Gnatiuk
40	Modules 1...n	47.38 days	Thu 10/10/19	Tue 11/26/19	Caleb Dyck, Justin Gnatiuk
41	Code (working subsystems)	47.38 days	Thu 10/10/19	Tue 11/26/19	Caleb Dyck, Justin Gnatiuk
42	System integration Behavior Mo	47.38 days	Thu 10/10/19	Tue 11/26/19	Caleb Dyck, Justin Gnatiuk
43	Parts Lists	47.38 days	Thu 10/10/19	Tue 11/26/19	Brice Brenneman, Mitch Wilson
44	Parts I list(s) for Schematics	47.38 days	Thu 10/10/19	Tue 11/26/19	Brice Brenneman, Mitch Wilson
45	Materials Budget list	47.38 days	Thu 10/10/19	Tue 11/26/19	Brice Brenneman, Mitch Wilson
46	Proposed Implementation Gantt Char	47.38 days	Thu 10/10/19	Tue 11/26/19	Caleb Dyck
47	Conclusions and Recommendations	47.38 days	Thu 10/10/19	Tue 11/26/19	Brice Brenneman, Caleb Dyck, Justin Gnatiuk, Mitch Wilson
48	Final Parts Request Form	10.38 days	Tue 10/15/19	Fri 10/25/19	Brice Brenneman, Mitch Wilson
49	Final Design Presentations Part 1	0 days	Thu 11/14/19	Thu 11/14/19	Brice Brenneman, Caleb Dyck, Justin Gnatiuk, Mitch Wilson
50	Final Design Presentations Part 2	0 days	Thu 11/21/19	Thu 11/21/19	Brice Brenneman, Caleb Dyck, Justin Gnatiuk, Mitch Wilson
51	Parts Request Form for Spring Semest	8.38 days	Wed 11/27/19	Thu 12/5/19	Brice Brenneman, Mitch Wilson

Figure 11: Gantt Chart DT11, Fall Semester 2019

10. Conclusions

MW - The intended goal for this paper is to research, design and prove the theory of operation for a completely hands-free door entry system. The objectives for the project are to develop the required hardware and software components necessary to accomplish voice actuated locking/unlocking, opening/closing, and security to standard household doors. The supporting hardware and control of the system have been realized, while also cohering to the underlying objectives. With this in mind, further development and testing of the system is necessary to fully implement the design. Furthermore, active prototyping of the E-Z Door will advance operation and functionality.

11. References

- [1] Lia Kamelia, Alfin Noorhassan S.R, Mada Sanjaya and W.S., Edi Mulyana, "Door-automation system using bluetooth-based android for mobile phone", *ARPJ Journal of Engineering and Applied Sciences*, Vol. 9, No. 10, Oct. 2014.
- [2] N. H. Ismail, Z. Tukiran, N. N. Shamsuddin and E. I. S. Saadon, "Android-based home door locks application via Bluetooth for disabled people," *2014 IEEE International Conference on Control System, Computing and Engineering (ICCSCE 2014)*, Batu Ferringhi, 2014, pp. 227-231.
- [3] R. Dinar Hayu Arifin and R. Sarno, "Door automation system based on speech command and PIN using Android smartphone," *2018 International Conference on Information and Communications Technology (ICOIACT)*, Yogyakarta, 2018, pp. 667-672.
- [4] Y. T. Park, P. Sthapit and J. Pyun, "Smart digital door lock for the home automation," *TENCON 2009 - 2009 IEEE Region 10 Conference*, Singapore, 2009, pp. 1-6.
- [5] Pradnya R. Nehete, J. P. Chaudhari, S. R. Pachpande, K. P. Rane, "Literature Survey on Door Lock Security Systems." *International Journal of Computer Applications (0975-8887)*, Vol. 153, No. 2, Nov. 2016.
- [6] Anjali Bala, Abhijeet Kumar, Nidhika Birla, "Voice Command Recognition System Based on MFCC and DTW", *International Journal of Engineering Science and Technology*, Vol. 2, 2010.
- [7] J. F. Buzhardt, "Smart door lock," U.S Patent 0170447, Jun. 18, 2015.
- [8] J. Johnson, "Intelligent door lock system retrofitted to existing door lock mechanism," U.S Patent 9767632, Sep. 19, 2017.

- [9] J. E. Eccleston, "Remotely controllable automatic door operator and closer," U.S Patent 6891479. May. 10, 2005.
- [10] S. Downs, A. Pollo, E. Bredemeier, "Residential Automatic Door Opener", *Washington University Open Scholarship*, Fall 2018
- [11] Gutierrez Pascual, M. Deseada. (2012). Indoor Location Systems based on ZigBee networks. 10.13140/2.1.4300.1126.

12. Appendix

A. Explorer 16/32 Product Information

https://www.microchip.com/developmenttools/ProductDetails/PartNo/DM240001-2?utm_source=MicroSolutions&utm_medium=Article&utm_content=DevTools&utm_campaign=StandAlone

B. Servo Motor Datasheet

<https://www.pololu.com/file/0J1434/FT5335M-specs.pdf>

C. Buck Converter Datasheet

<http://www.ti.com/lit/ds/symlink/lmz22005.pdf>

D. Microphone Datasheet

<https://cdn-shop.adafruit.com/datasheets/MAX4465-MAX4469.pdf>