



University of Groningen

## A new microdialysis probe for continuous lactate measurement during fetal monitoring

Tigchelaar, Froukje; Groen, Henk; Westgren, Magnus; Huinink, Kirsten D.; Cremers, Thomas; van den Berg, Paul P.

*Published in:*  
Acta Obstetricia et Gynecologica Scandinavica

*DOI:*  
[10.1111/aogs.13865](https://doi.org/10.1111/aogs.13865)

**IMPORTANT NOTE: You are advised to consult the publisher's version (publisher's PDF) if you wish to cite from it. Please check the document version below.**

*Document Version*  
Publisher's PDF, also known as Version of record

*Publication date:*  
2020

[Link to publication in University of Groningen/UMCG research database](#)

### *Citation for published version (APA):*

Tigchelaar, F., Groen, H., Westgren, M., Huinink, K. D., Cremers, T., & van den Berg, P. P. (2020). A new microdialysis probe for continuous lactate measurement during fetal monitoring: Proof of concept in an animal model. *Acta Obstetricia et Gynecologica Scandinavica*, 99(10), 1411-1416. <https://doi.org/10.1111/aogs.13865>

### **Copyright**

Other than for strictly personal use, it is not permitted to download or to forward/distribute the text or part of it without the consent of the author(s) and/or copyright holder(s), unless the work is under an open content license (like Creative Commons).

### **Take-down policy**

If you believe that this document breaches copyright please contact us providing details, and we will remove access to the work immediately and investigate your claim.

*Downloaded from the University of Groningen/UMCG research database (Pure): <http://www.rug.nl/research/portal>. For technical reasons the number of authors shown on this cover page is limited to 10 maximum.*

# A new microdialysis probe for continuous lactate measurement during fetal monitoring: Proof of concept in an animal model

Froukje Tigchelaar<sup>1</sup> | Henk Groen<sup>2</sup> | Magnus Westgren<sup>3</sup> | Kirsten D. Huinink<sup>4</sup> | Thomas Cremers<sup>5,6</sup> | Paul P. van den Berg<sup>7</sup> 

<sup>1</sup>Faculty of Medical Sciences, University of Groningen, Groningen, the Netherlands

<sup>2</sup>Department of Epidemiology, University of Groningen, University Medical Center Groningen, Groningen, the Netherlands

<sup>3</sup>Clintec, Karolinska Institutet, Stockholm, Sweden

<sup>4</sup>Brainlink B.V., Groningen, the Netherlands

<sup>5</sup>CAN Holding B.V., Groningen, the Netherlands

<sup>6</sup>Department of Pharmaceutical Analysis, Faculty of Science and Engineering, University of Groningen, Groningen, the Netherlands

<sup>7</sup>Department of Obstetrics & Gynecology, University of Groningen, University Medical Centre Groningen, Groningen, the Netherlands

## Correspondence

Paul P. van den Berg, Department of Obstetrics & Gynecology, University Medical Centre Groningen, HPC CB20, PO Box 30 001, 9700 RB Groningen, The Netherlands.  
Email: p.p.van.den.berg@umcg.nl

## Abstract

**Introduction:** Cardiotocography (CTG) is currently the most commonly used method for intrapartum fetal monitoring during labor. However, a high false-positive rate of fetal acidosis indicated by CTG leads to an increase in obstetric interventions. We developed a microdialysis probe that is integrated into a fetal scalp electrode allowing continuous measurement of lactate subcutaneously, thus giving instant information about the oxygenation status of the fetus. Our aim was to establish proof of concept in an animal model using a microdialysis probe to monitor lactate subcutaneously.

**Material and methods:** We performed an in vivo study in adult male wild-type Wistar rats. We modified electrodes used for CTG monitoring in human fetuses to incorporate a microdialysis membrane. Optimum flow rates for microdialysis were determined in vitro. For the in vivo experiment, a microdialysis probe was inserted into the skin on the back of the animal. De-oxygenation and acidosis were induced by lowering the inspiratory oxygen pressure. Oxygenation and heart rate were monitored. A jugular vein cannula was inserted to draw blood samples for analysis of lactate, pH, pCO<sub>2</sub>, and saturation. Lactate levels in dialysate were compared with plasma lactate levels.

**Results:** Baseline blood lactate levels were around 1 mmol/L. Upon de-oxygenation, oxygen saturation fell to below 40% for 1 h and blood lactate levels increased 2.5-fold. Correlation of dialysate lactate levels with plasma lactate levels was 0.89 resulting in an R<sup>2</sup> of .78 in the corresponding linear regression.

**Conclusions:** In this animal model, lactate levels in subcutaneous fluid collected by microdialysis closely reflected blood lactate levels upon transient de-oxygenation, indicating that our device is suitable for subcutaneous measurement of lactate. Microdialysis probe technology allows the measurement of multiple compounds in the dialysate, such as glucose, albumin, or inflammatory mediators, so this technique may offer the unique possibility to shed light on fetal physiology during the intrapartum period.

**Abbreviations:** CTG, cardiotocography.

This is an open access article under the terms of the Creative Commons Attribution-NonCommercial-NoDerivs License, which permits use and distribution in any medium, provided the original work is properly cited, the use is non-commercial and no modifications or adaptations are made.

© 2020 The Authors. *Acta Obstetrica et Gynecologica Scandinavica* published by John Wiley & Sons Ltd on behalf of Nordic Federation of Societies of Obstetrics and Gynecology (NFOG)

## KEYWORDS

cardiotocography, cesarean, delivery, fetal acidosis, fetal monitoring, fetal scalp electrode, lactate, prenatal care

## 1 | INTRODUCTION

During labor, the well-being of the fetus is monitored to identify those fetuses that may become hypoxic and might benefit from interventions such as cesarean section or instrumental delivery. When perinatal hypoxia persists, it may result in perinatal asphyxia, a major cause of neonatal death and morbidity.<sup>1,2</sup>

Cardiotocography (CTG) is currently the most commonly used method for continuous fetal monitoring during labor. However, there is no good evidence that supports the benefits of this method. Also, use of CTG during labor is associated with a significant increase in cesarean sections. Other disadvantages include subjectivity in the interpretation of the results and decreased mobility for the woman during labor.<sup>3</sup>

Fetal scalp blood sampling for pH or lactate analysis is used in addition to CTG and may reduce the risk of cesarean section compared with CTG alone.<sup>4</sup> Although this method is referred to as the reference standard for investigation of fetal acidosis in labor, it has not been shown to result in significantly lower cesarean section rates or to improve fetal outcome.<sup>5-7</sup>

Other alternatives have been suggested. These include ST-segment analysis of the fetal electrocardiography, fetal pulse oximetry, and near-infrared spectroscopy.<sup>3,8</sup> However, a convincing significant benefit over CTG has not been shown for any of these methods.<sup>9-11</sup> Therefore, a method for intrapartum fetal monitoring that more accurately discriminates between absence and presence of hypoxia should be developed.

During prolonged hypoxia, anaerobic glycolysis as energy source causes metabolic acidosis and lactate accumulation in peripheral blood; a high blood lactate concentration at birth is a predictor of poor outcome in children.<sup>11</sup> To measure fetal lactate, blood sampling from the fetal scalp can be performed during labor as a single or repeated procedure.<sup>12</sup> There is evidence suggesting that measurement of lactate is more feasible than of pH.<sup>13,14</sup>

We developed a microdialysis probe integrated into a fetal scalp CTG electrode allowing continuous measurement of lactate and giving instant information about the oxygenation status of the fetus (European Patent No. 15726201.5, 2015).<sup>15</sup>

The aim of this study was to establish proof of concept by investigating whether our microdialysis probe can be used to monitor lactate subcutaneously in vivo in the hypoxic rat.

## 2 | MATERIAL AND METHODS

### 2.1 | Description of the device

We modified electrodes used for CTG monitoring in human fetuses to incorporate a microdialysis membrane. A hypodermic

### Key message

In a rat model, lactate levels in subcutaneous fluid collected by microdialysis closely reflected blood lactate levels upon transient oxygen deprivation. This method could potentially be used as a tool for intrapartum human fetal monitoring.

needle (25G×5/8, B. Braun) was modified to accommodate a microdialysis membrane (regenerated cellulose, L = 3.0 mm, pores: 18 kDa). The end of the microdialysis membrane was glued shut (Pattex). Sterile saline or phosphate-buffered saline was infused along the membrane via fused silica tubings (Polymicro, TSP040105) and returned to the outlet via another fused silica membrane. The microdialysis probe was connected to a sterile syringe filled with sterile saline or phosphate-buffered saline using PEEK tubing (internal diameter 127 μm, outer diameter 508 μm; Western Analytical).

Figure 1A shows the position of the needle at the tip of the CTG electrode, which has a coiled electrode wire to attach it to the skin by turning it with gentle pressure. The microdialysis needle is positioned in such a way that the point of the needle does not extend beyond the coiled electrode, preventing damage to the deeper structures by the needle. Upon insertion of the CTG electrode in the scalp, the needle pierces the scalp, enabling sampling of the extracellular fluid.

Figure 1B shows the principle of the dialysis setup. Briefly, dialysate fluid enters the dialysis setup through fused silica tubing and returns via the membrane to the outlet. Exchange of small molecules will occur between dialysis fluid and the subcutaneous fluid in the skin through an open surface of 3 mm when dialysis fluid runs along the microdialysis membrane. After passing the dialysis membrane, fluid can be collected for analysis of lactate.

### 2.2 | In vitro experiments

Before the in vivo experiments, the microdialysis setup was tested in vitro to determine optimum flow rates with respect to recovery of lactate. For this purpose, the device was attached to a syringe pump (CMA 102; CMA Microdialysis AB) and perfused with saline at flow rates of 1.5 μL/min (n = 4) and 5 μL/min (n = 2). The dialysis device was then suspended in a 50-mL beaker containing stirred lactate solutions with a concentration of 10 mmol/L. The observed relative recoveries of lactate at flow rates of 1.5 and 5 μL/min were 24.7%

( $\pm 2.3$ ) and 8.9% ( $\pm 0.6$ ), respectively, and the lowest flow rate was chosen for the in vivo experiments.

## 2.3 | In vivo experiments

Three adult male wild-type Wistar rats, each weighing approximately 500 g, were used for the experiments. The animals were ventilated through a breathing mask to regulate the supply of oxygen and nitrogen (baseline: oxygen 0.8 L/min, nitrogen 0 L/min) and were anesthetized using isoflurane. After shaving, the microdialysis probe was inserted in the skin of the back of the animal and fixed in place with a suture. A pulse oximeter was clamped to the tail of the animal to monitor oxygenation and heart rate. A jugular vein cannula was inserted to draw blood samples of 100  $\mu$ L each, every 10 min, for analysis of lactate, pH,  $p\text{CO}_2$ , and saturation.

After stabilization for 15 min, dialysis sampling was started and acidosis was induced by simultaneously increasing nitrogen flow (0.8 L/min) and decreasing oxygen flow (0.05 L/min). De-oxygenation lasted for 60 min, after which restoration of saturation was induced using 0.8 L/min oxygen. Lactate and saturation were monitored for a further 20 min while saturation was restored.

Dialysis was performed using sterile saline solution at 1.5  $\mu$ L/min. Samples were collected in 300- $\mu$ L polypropylene vials, for lactate analysis. Lactate, pH,  $p\text{CO}_2$ , and saturation in blood samples were analyzed using a handheld Abbott analyzer (Abbott analyzer; Abbott Diagnostics). Lactate from dialysis samples was quantified with an enzymatic assay in a 96-well plate (reagents from CMA Microdialysis AB).

## 2.4 | Ethical approval

All experiments were in accordance with Dutch law and were approved by the animal ethics committee of the University of Groningen (31.04.2015, 5810A).

## 3 | RESULTS

### 3.1 | In vivo experiments

#### 3.1.1 | Peripheral lactate, oxygenation, pH, and $p\text{CO}_2$

Figure 2 shows the course of oxygen saturation and lactate over time. Upon de-oxygenation ( $t = 0$  minute), saturation fell to below 40% for 1 h. Baseline blood lactate levels were around 1 mmol/L. Blood lactate levels increased 2.5-fold upon de-oxygenation, starting within 10 min after initiation of de-oxygenation. Upon restoration of oxygenation, lactate levels returned to baseline levels rapidly.

Blood pH slowly decreased over the course of the experiment, and did not return to baseline within 20 min after oxygenation was restored. Similarly,  $p\text{CO}_2$  slowly increased, starting after 40 min of de-oxygenation, and kept rising upon re-oxygenation (Figure 3).

#### 3.1.2 | Skin microdialysis of lactate

Figure 4 depicts the lactate levels measured in dialysate and blood. Dialysate levels increased in a similar way to plasma levels

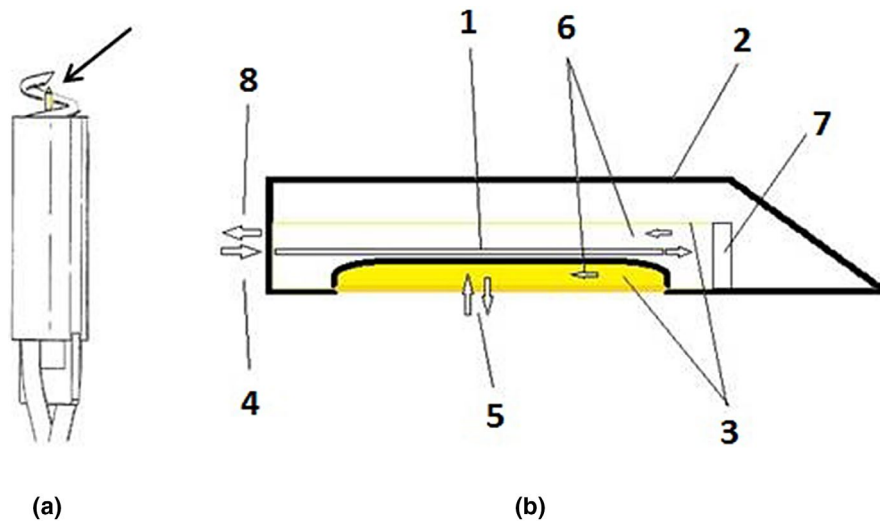
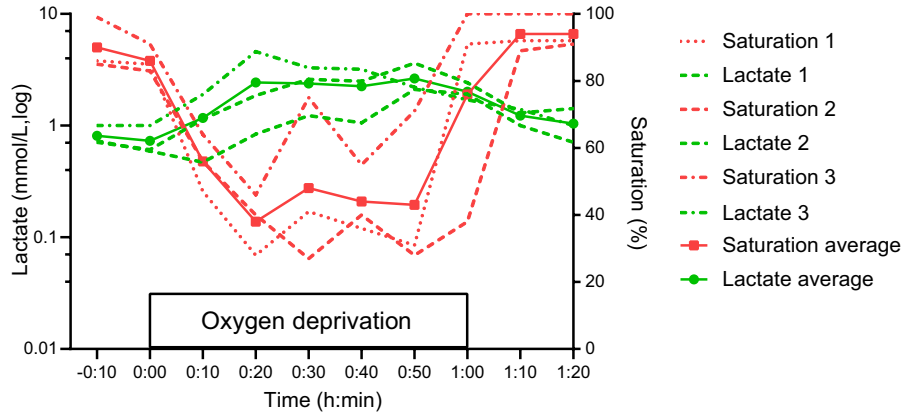

**FIGURE 1** A, A schematic representation of a cardiotochography (CTG) electrode modified to incorporate a needle-type microdialysis setup. The arrow denotes the positioning of the needle. B, A semi open needle (2), in which a microdialysis membrane is inserted (3), in which thin fused silica tubing is inserted (1). When dialysis fluid is pushed through the fused silica (4), the flow will leave the fused silica at the other end and be forced back (6), because the membrane is blocked by glue (7). While running back along the microdialysis membrane, exchange (5) of small molecules will occur between the dialysis fluid and the external fluid space. Fluid can be collected for analysis when leaving the dialysis membrane (8)

upon de-oxygenation. When dialysate levels were corrected for in vitro recovery, plasma and dialysate levels were comparable (data not shown). Correlation of dialysate lactate levels with plasma lactate levels was 0.89, resulting in an  $R^2$  of .78 in the corresponding linear regression.

## 4 | DISCUSSION

In this study, we investigated whether microdialysis can be used to monitor subcutaneous lactate concentrations in the hypoxic rat. We were able to measure and compare the changes over time in



**FIGURE 2** Oxygen saturation and blood lactate levels upon de-oxygenation for 60 min. Red lines depict saturation levels in 3 animals (percentage, right y-axis), green lines represent corresponding blood lactate levels (mmol/L, left y-axis). Red squares represent average oxygen saturation, green circles represent average blood lactate

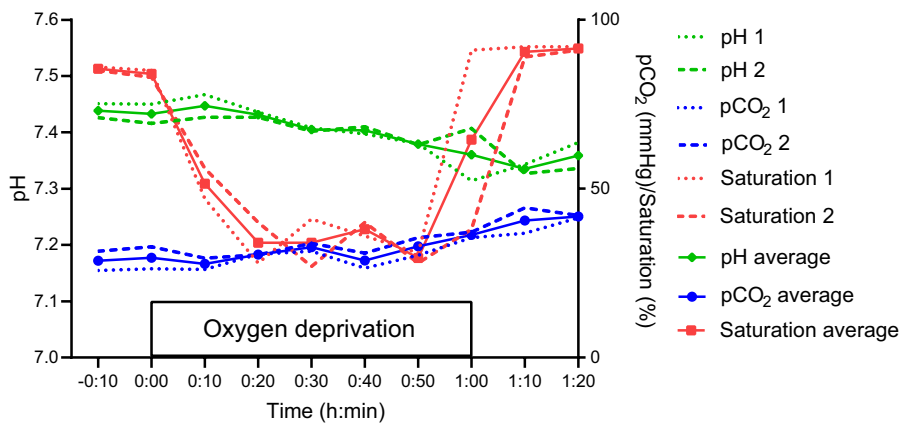

**FIGURE 3** Oxygenation,  $pCO_2$  and pH upon de-oxygenation for 60 min. Red lines depict saturation in 2 animals (percentage, right y-axis), blue lines depict corresponding  $pCO_2$  levels (mm Hg, right y-axis) and green lines represent corresponding pH values (left y-axis). Red squares depict average saturation, blue circles depict average  $pCO_2$  values and green diamonds depict average pH

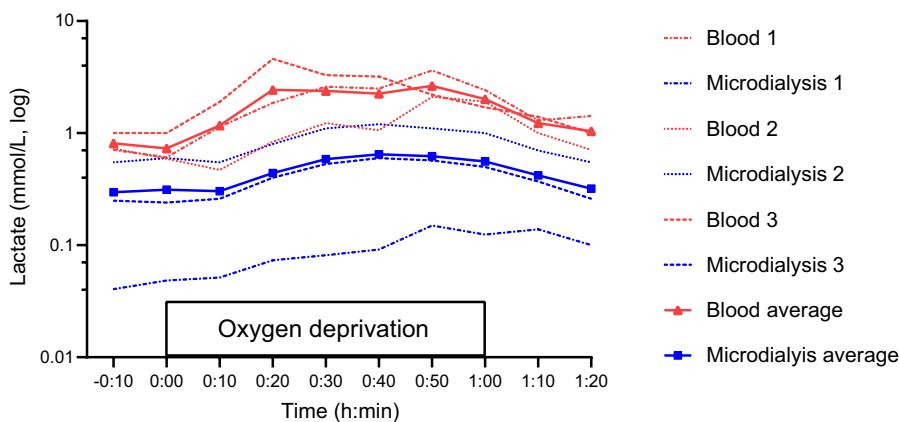

**FIGURE 4** Blood and dialysis lactate levels upon de-oxygenation for 60 min. Red lines depict blood lactate levels in 3 animals, blue lines represent corresponding dialysis lactate levels (mmol/L). Red triangles depict average blood lactate, blue squares represent average lactate in dialysate

subcutaneous and blood lactate levels. The observed agreement between both methods of lactate measurement supports further studies to determine the suitability of this method for clinical applications, for example, intrapartum human fetal monitoring.

We found an *in vitro* recovery of 24.7% for lactate in dialysate at a flow rate of 1.5  $\mu\text{L}/\text{min}$ . This corresponds to values found for a flow rate of 1  $\mu\text{L}/\text{min}$  in previous studies.<sup>16,17</sup> A higher flow rate of 5  $\mu\text{L}$  resulted in a recovery of 8.9%. Although a lower flow rate improves recovery, it increases the lag time between lactate measured in blood and dialysate.

Our results showed a good agreement between plasma and dialysate lactate levels. Lactate levels from microdialysis followed blood lactate levels with a lag time of about 10 min, increasing and decreasing similarly over time, and showing comparable values after correction for recovery. This suggests that microdialysis in subcutaneous tissue can be used to monitor lactate as an alternative to blood analysis in the jugular vein.

Our microdialysis probe offers a new approach to continuous measurement of lactate and other compounds. Microdialysis as a sampling technique to measure the concentrations of different metabolites in the interstitial fluid in the skin has been used for several purposes. In diabetes, in conjunction with a biosensor, it has been shown to be a reliable method to continuously measure glucose with high accuracy and very little discomfort for the patient.<sup>18,19</sup>

A study by Poscia et al.<sup>20</sup> showed that the glucose monitoring system based on biosensor technology can be modified for continuous measurement of lactate in rabbits. Preliminary data suggest that this technique can be used for lactate measurement in humans for up to 16 h. Other studies show that microdialysis probes in the upper dermal tissue of the skin can measure lactate accurately, and that microdialysis lactate and glucose concentrations correspond to plasma concentrations.<sup>21,22</sup>

Clinical device requirements for a biosensor monitoring lactate in human tissue are manifold. The materials used should be biocompatible. Any chemicals used for sensing must be affixed in a way that ensures that they do not separate from the sensor surface. Manufacturers will need to demonstrate that chemical leakage into surrounding tissue poses no health risk. Accuracy and stability of the sensor can be affected by bio-fouling, which can be caused by protein absorption, cellular adhesion, thrombus formation, and more.<sup>23</sup> The microdialysis technique we used adheres to these qualifications.

Biosensors are designed to measure one specific compound. The microdialysis probe technology used in the present study allows the measurement of multiple compounds in the dialysate, such as glucose, albumin, or inflammatory mediators.<sup>24</sup> However, compounds can only be measured if their molecules can cross the microdialysis membrane. We used a membrane with pores of 18 kDa that small molecules (lactate: 90 Da) can easily pass through.

With the current design of our probe, placement of the probe is not more invasive than placement of a conventional CTG electrode. The flow rate required for the measurement is very low and comparable to studies in other fields, for example, in a clinical study

on neurosurgical patients by Hutchinson et al.<sup>25</sup> As no transfer of fluid occurs with microdialysis due to tissue pressure, this method induces no tissue trauma during sampling. Additionally, in case of blockage of the outflow tract and leakage of the microdialysis membrane, the cumulative amount of fluid perfused into the fetal scalp is very low (90  $\mu\text{L}/\text{h}$ ), and so not likely to harm the fetus or influence the birthing process in any way. In all, the current sampling technique would provide a safe and versatile method for monitoring the metabolic status of the fetus.

This is the first study investigating a novel application of microdialysis for possible future use in the field of obstetrics. With the setup of this study, we were able to measure and compare the changes in lactate levels in subcutaneous tissue and in blood over time in hypoxic rats. The observed agreement between both methods of lactate measurement supports further studies to determine the suitability of this method for several clinical applications.

Because it was a study in rats, we should be careful to generalize the results to human beings. Clinical studies in human settings are necessary to establish feasibility and validity. Lag time between lactate in serum and in subcutaneous tissue and stability of the measurements are issues that we are addressing in ongoing studies.

## 5 | CONCLUSION

In this animal model, lactate levels in tissue fluid collected with microdialysis reflected blood lactate levels upon transient deprivation of oxygen. These results confirm that our microdialysis device is suitable for subcutaneous measurement of lactate. As the microdialysis probe technology allows measurement of multiple compounds in the dialysate, this technique may offer the unique possibility to shed light on fetal physiology during the intrapartum period.

## CONFLICT OF INTEREST

Th. Cremers is CEO of Can Holding BV and KD Huinink is CEO of Brainlink BV. The other authors declare no conflicts of interest.

## ORCID

Paul P. van den Berg  <https://orcid.org/0000-0003-2241-3001>

## REFERENCES

1. Ahearne CE, Boylan GB, Murray DM. Short and long term prognosis in perinatal asphyxia: an update. *World J Clin Pediatr.* 2016;5(1):67-74.
2. Fattuoni C, Palmas F, Noto A, Fanos V, Barberini L. Perinatal asphyxia: a review from a metabolomics perspective. *Molecules.* 2015;20(4):7000-7016.
3. Alfirevic Z, Devane D, Gyte GM. Continuous cardiotocography (CTG) as a form of electronic fetal monitoring (EFM) for fetal assessment during labour. *Cochrane Database Syst Rev.* 2013;5:CD006066.
4. Van den Berg P, Schmidt S, Gesche J, Saling E. Fetal distress and the condition of the newborn using cardiotocography and fetal blood analysis during labour. *Br J Obstet Gynaecol.* 1987;94(1):72-75.
5. East CE, Leader LR, Sheehan P, Henshall NE, Colditz PB, Lau R. Intrapartum fetal scalp lactate sampling for fetal assessment in

- the presence of a non-reassuring fetal heart rate trace. *Cochrane Database Syst Rev.* 2015;5:CD006174.
6. Jorgensen JS, Weber T. Fetal scalp blood sampling in labor – a review. *Acta Obstet Gynecol Scand.* 2014;93:548-555.
  7. Mahendru AA, Lees CC. Is intrapartum fetal blood sampling a gold standard diagnostic tool for fetal distress? *Eur J Obstet Gynecol Reprod Biol.* 2011;156(2):137-139.
  8. Cahill AG, Spain J. Intrapartum fetal monitoring. *Clin Obstet Gynecol.* 2015;58(2):263-268.
  9. Belfort MA, Saade GR, Thom E, et al. A randomized trial of intrapartum fetal ECG ST-segment analysis. *N Engl J Med.* 2015;373(7):632-641.
  10. East CE, Begg L, Colditz PB, Lau R. Fetal pulse oximetry for fetal assessment in labour. *Cochrane Database Syst Rev.* 2014;10:CD004075.
  11. Mozurkewich E, Wolf FM. Near-infrared spectroscopy for fetal assessment during labour. *Cochrane Database Syst Rev.* 2000;3:CD002254.
  12. Fine-Goulden MR, Durward A. How to use lactate. *Arch Dis Child Educ Pract Ed.* 2014;99(1):17-22.
  13. Ramanah R, Martin A, Clement MC, Maillet R, Riethmuller D. Fetal scalp lactate microsampling for non-reassuring fetal status during labor: a prospective observational study. *Fetal Diagn Ther.* 2010;27(1):14-19.
  14. Kruger K, Hallberg B, Blennow M, Kublickas M, Westgren M. Predictive value of fetal scalp blood lactate concentration and pH as markers of neurologic disability. *Am J Obstet Gynecol.* 1999;181(5 Pt 1):1072-1078.
  15. Van den Berg P. European Patent No. 15726201.5, 2015; Retrieved from European Patent Office website. 2015. <https://worldwide.espacenet.com>.
  16. Hutchinson PJ, O'Connell MT, al-Rawi PG, et al. Clinical cerebral microdialysis – determining the true extracellular concentration. *Acta Neurochir Suppl.* 2002;81:359-362.
  17. Lietsche J, Gorka J, Hardt S, Karas M, Klein J. Custom-made microdialysis probe design. *J Vis Exp.* 2015;101:e53048.
  18. Maran A, Crepaldi C, Tiengo A, et al. Continuous subcutaneous glucose monitoring in diabetic patients: a multicenter analysis. *Diabetes Care.* 2002;25:347-352.
  19. Varalli M, Marelli G, Maran A, et al. A microdialysis technique for continuous subcutaneous glucose monitoring in diabetic patients (part 2). *Biosens Bioelectron.* 2003;18(7):899-905.
  20. Poscia A, Messeri D, Moscone D, Ricci F, Valgimigli F. A novel continuous subcutaneous lactate monitoring system. *Biosens Bioelectron.* 2005;20(11):2244-2250.
  21. Jansson PA, Krogstad AL, Lonroth P. Microdialysis measurements in skin: evidence for significant lactate release in healthy humans. *Am J Physiol.* 1996;271(1 Pt 1):E138-E142.
  22. Petersen LJ. Interstitial lactate levels in human skin at rest and during an oral glucose load: a microdialysis study. *Clin Physiol.* 1999;19(3):246-250.
  23. Cummins G, Kremer J, Bernassau A, et al. Sensors for fetal hypoxia and metabolic acidosis: a review. *Sensors.* 2018;18(8):2648.
  24. Khan F, Pharo A, Lindstad JK, Mollnes TE, Tonnessen TI, Pischke SE. Effect of perfusion fluids on recovery of inflammatory mediators in microdialysis. *Scand J Immunol.* 2015;82(5):467-475.
  25. Hutchinson PJ, O'Connell MT, Al-Rawi PG, et al. Clinical cerebral microdialysis: a methodological study. *J Neurosurg.* 2000;93(1):37-43.

**How to cite this article:** Tigchelaar F, Groen H, Westgren M, Huinink KD, Cremers T, van den Berg PP. A new microdialysis probe for continuous lactate measurement during fetal monitoring: Proof of concept in an animal model. *Acta Obstet Gynecol Scand.* 2020;00:1–6. <https://doi.org/10.1111/aogs.13865>