

University of Nebraska - Lincoln

DigitalCommons@University of Nebraska - Lincoln

UCARE Research Products

UCARE: Undergraduate Creative Activities &
Research Experiences

Spring 4-1-2020

POOL BOILING INVERSION ON FEMTOSECOND LASER SURFACE PROCESSED 304 STAINLESS STEEL AND ITS IMPACT ON STEADY-STATE TIME CONSTANTS

Justin Costa-Greger

University of Nebraska-Lincoln, jcosta-greger@huskers.unl.edu

Alfred Tsubaki

University of Nebraska-Lincoln, s-atsubak1@unl.edu

Josh Gerdes

jgerdes@huskers.unl.edu

Mark Anderson

University of Nebraska-Lincoln, mark.anderson@huskers.unl.edu

Craig Zuhlke

University of Nebraska-Lincoln, czuhlke@unl.edu

See next page for additional authors

Follow this and additional works at: <https://digitalcommons.unl.edu/ucareresearch>

 Part of the [Heat Transfer, Combustion Commons](#), and the [Nanotechnology Fabrication Commons](#)

Costa-Greger, Justin; Tsubaki, Alfred; Gerdes, Josh; Anderson, Mark; Zuhlke, Craig; Alexander, Dennis; Shield, Jeff; and Gogos, George, "POOL BOILING INVERSION ON FEMTOSECOND LASER SURFACE PROCESSED 304 STAINLESS STEEL AND ITS IMPACT ON STEADY-STATE TIME CONSTANTS" (2020). *UCARE Research Products*. 245.

<https://digitalcommons.unl.edu/ucareresearch/245>

This Poster is brought to you for free and open access by the UCARE: Undergraduate Creative Activities & Research Experiences at DigitalCommons@University of Nebraska - Lincoln. It has been accepted for inclusion in UCARE Research Products by an authorized administrator of DigitalCommons@University of Nebraska - Lincoln.

Authors

Justin Costa-Greger, Alfred Tsubaki, Josh Gerdes, Mark Anderson, Craig Zuhlke, Dennis Alexander, Jeff Shield, and George Gogos



POOL BOILING INVERSION ON FEMTOSECOND LASER SURFACE PROCESSED 304 STAINLESS STEEL AND ITS IMPACT ON STEADY-STATE TIME CONSTANTS

Justin Costa-Greger, Alfred Tsubaki, Josh Gerdes, Mark Anderson, Craig Zuhlke, Dennis Alexander, Jeff Shield, and George Gogos

MOTIVATION

- Increase heat transfer performance through passive surface modification
- Increased heat transfer can occur with changes in surface morphology
- Heat transfer enhancement has been seen through modified surface roughness, wettability, chemistry, and patterned micro/nanoscale features
- Femtosecond laser surface processing (FLSP) has been shown to significantly impact heat transfer performance
- Boiling inversion has recently been shown to dramatically enhance heat transfer coefficients at elevated heat fluxes

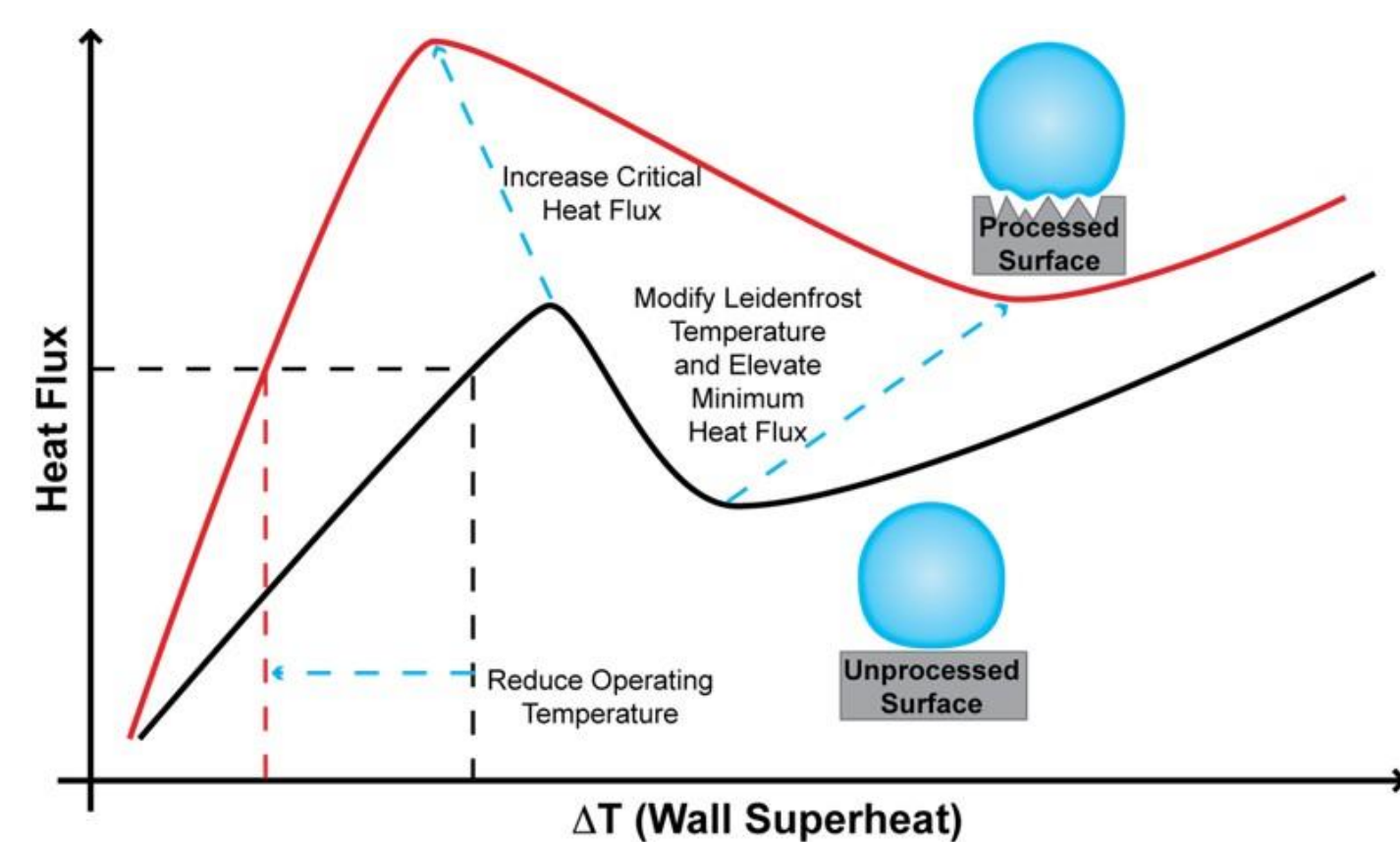

Fig. 1: Typical and enhanced boiling curves.

EXPERIMENTAL SETUP

- Processed surface (25.4 mm diameter) is heated using embedded cartridge heaters and two-phase heat transfer occurs at surface/liquid interface
- Heat flux is calculated using temperature gradient measured by thermocouples in copper block
- Surface temperature is extrapolated using the calculated heat flux
- Superheat is calculated by subtracting the liquid saturation temperature from the surface temperature
- Heat flux is plotted with respect to surface superheat

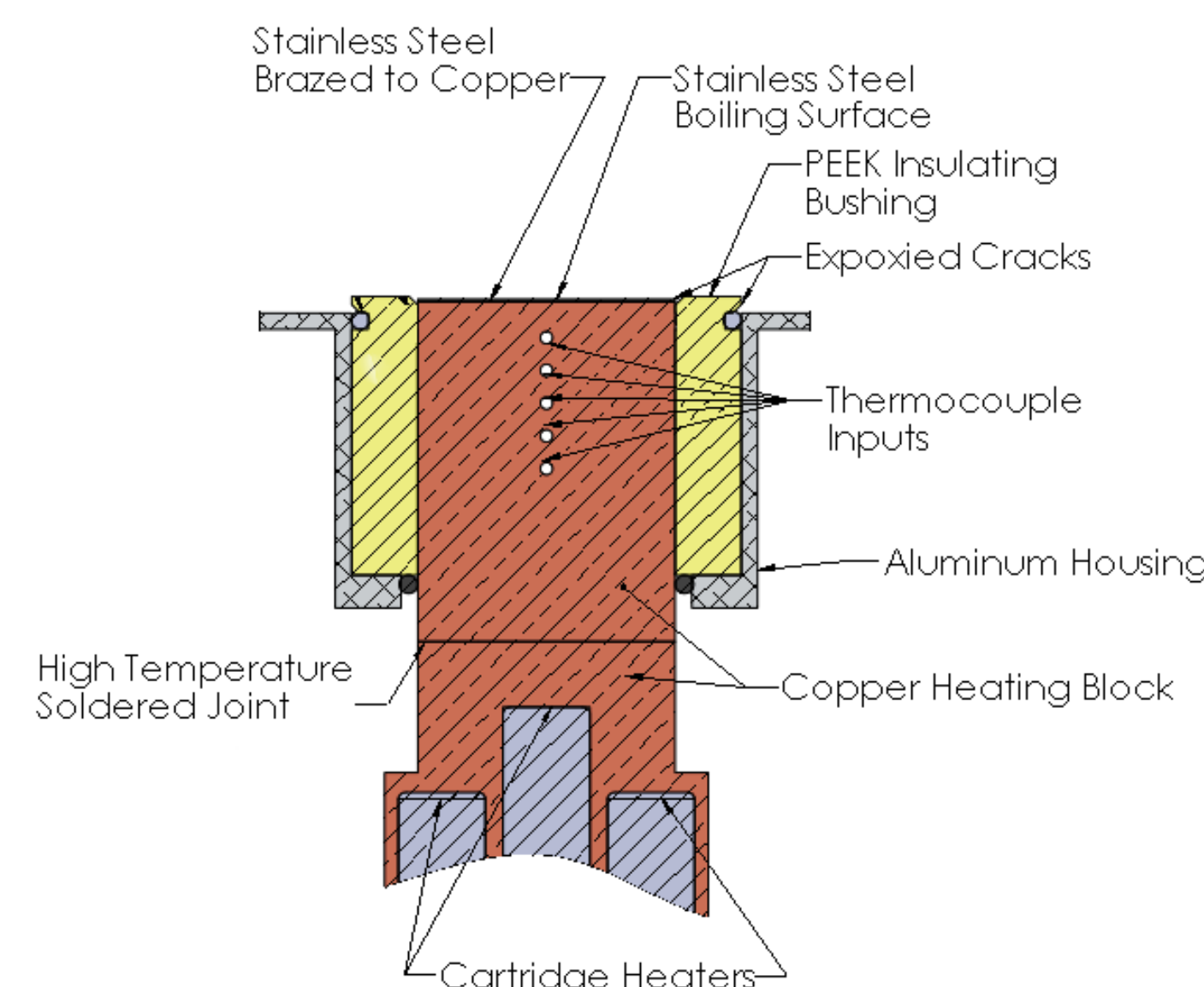

Fig. 4: Schematic of cross-section of pool boiling sample.

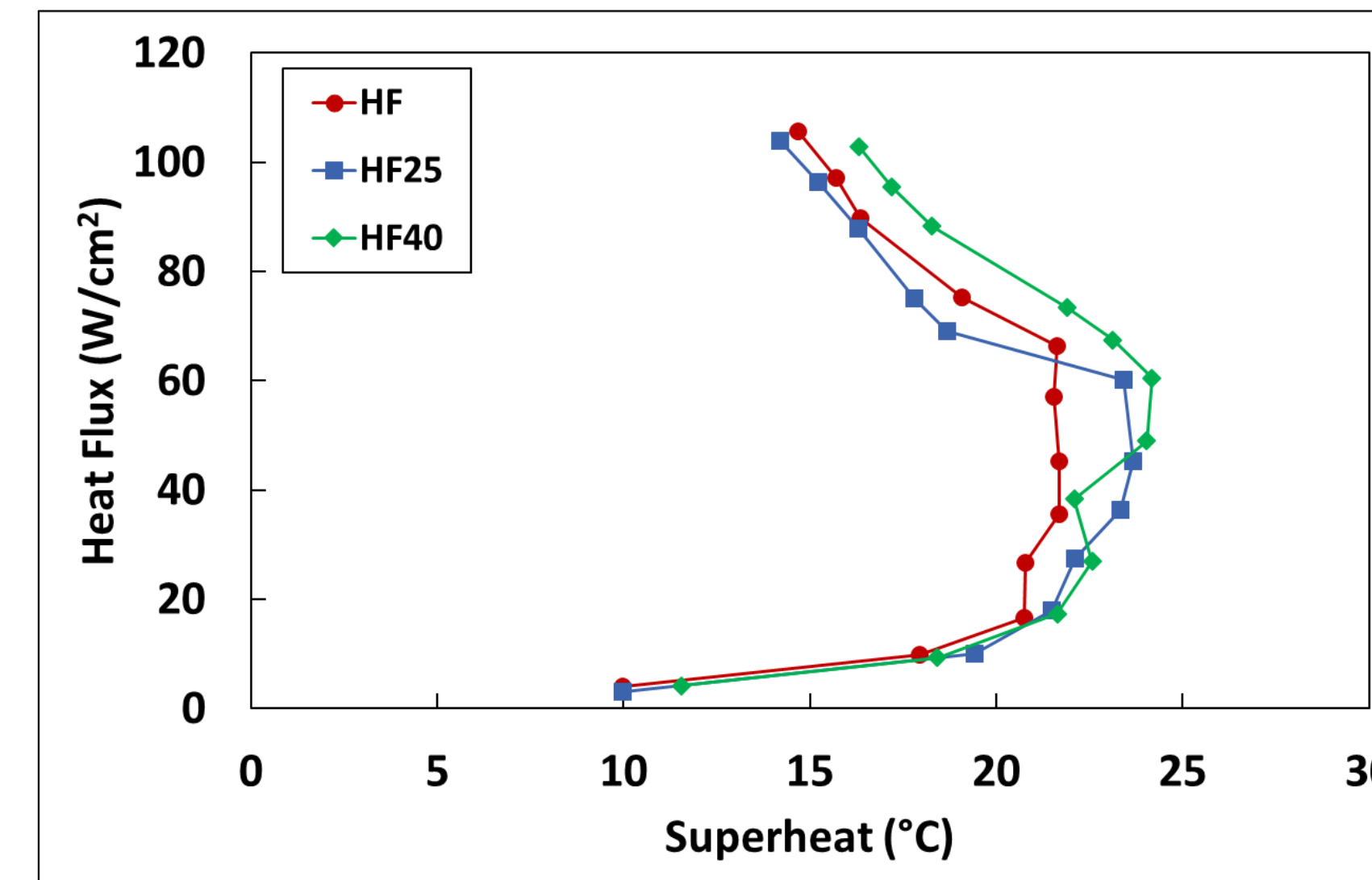

Fig. 5: Increasing heat flux curves for extended boiling at heat fluxes below boiling inversion point.

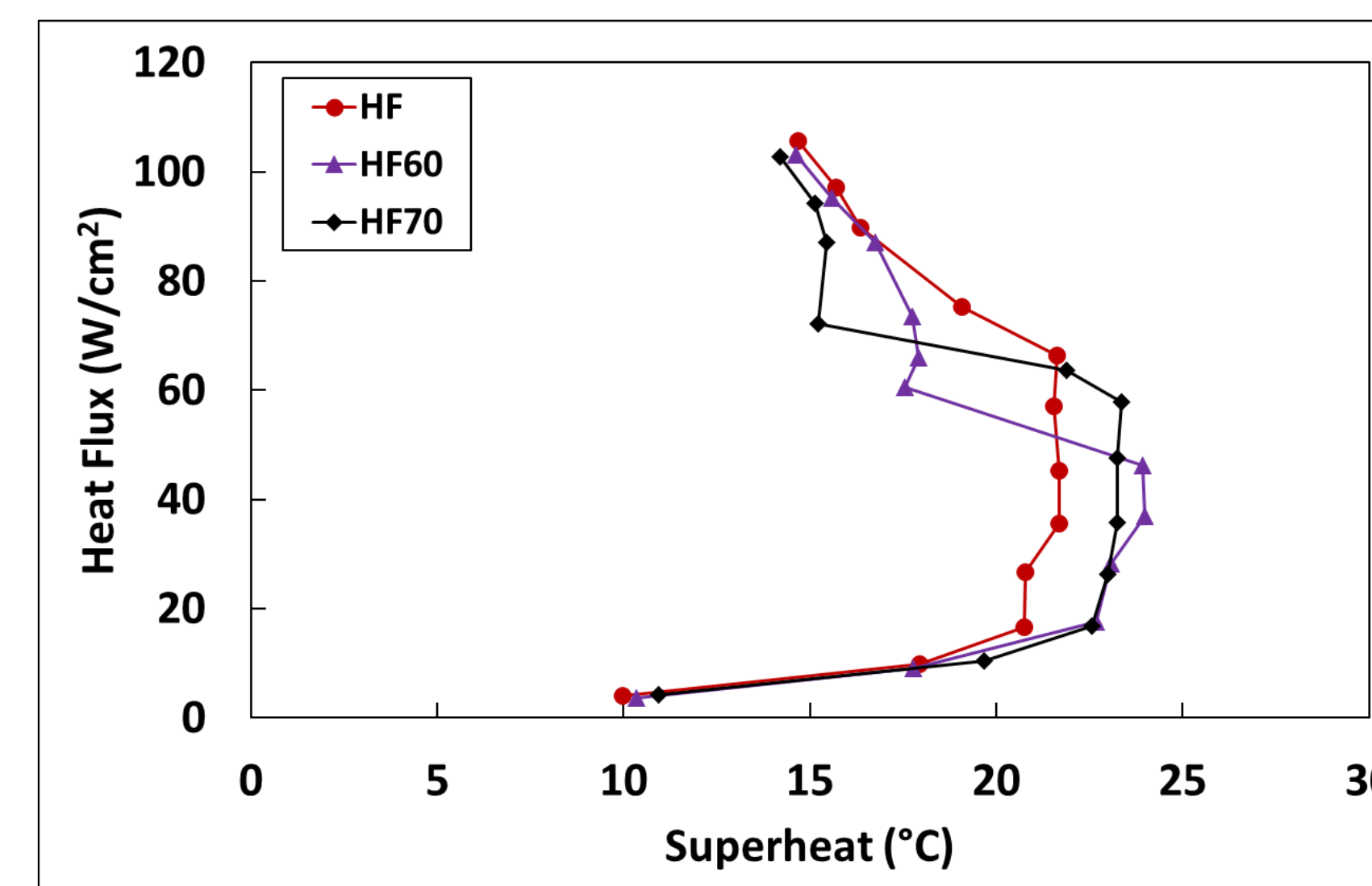

Fig. 6: Increasing heat flux curves for extended boiling at heat fluxes above boiling inversion point.

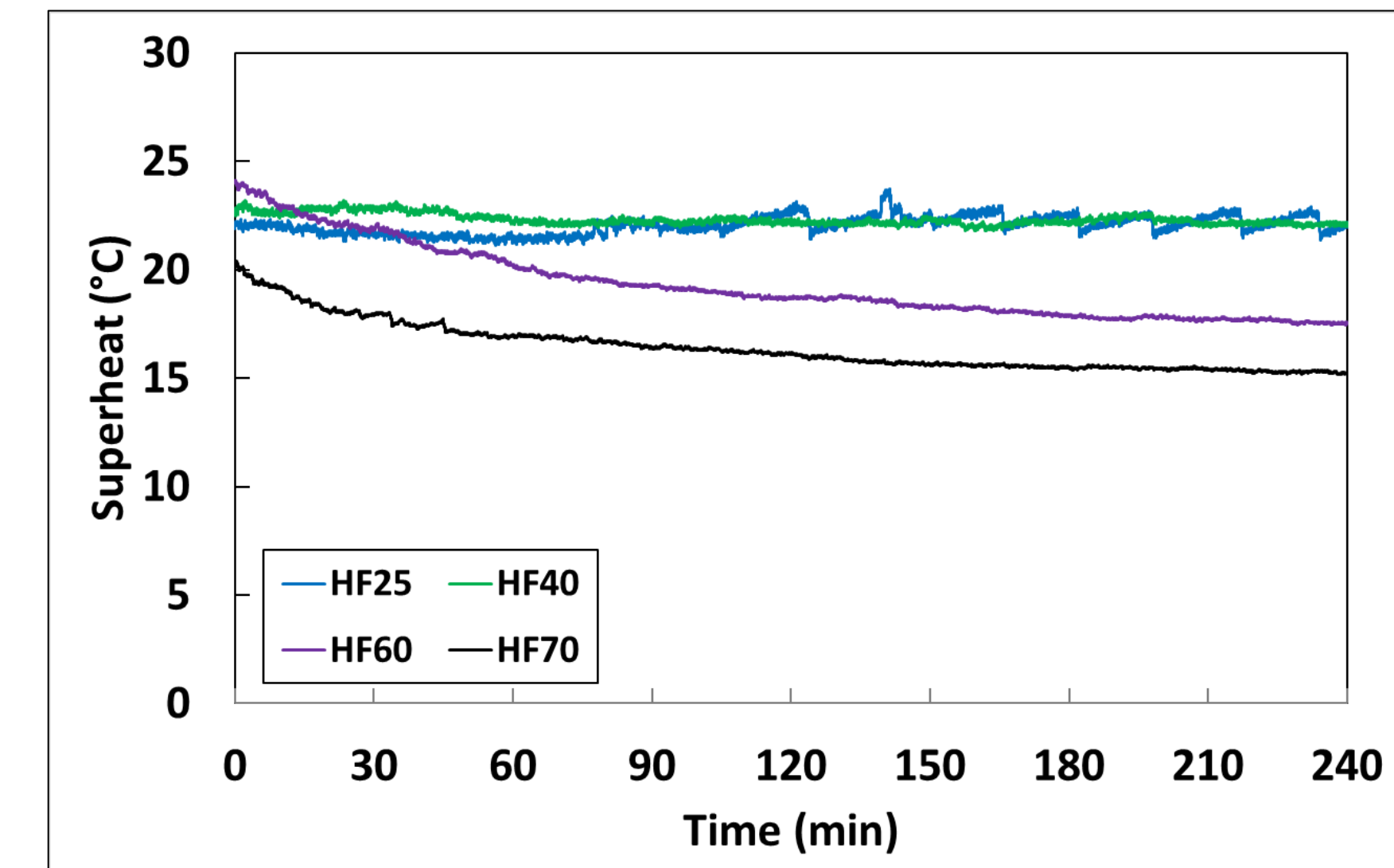

Fig. 7: Surface superheat versus time during extended boiling

- After inversion occurs, a large number of nucleation sites activate, however, the rate of activation is not well understood
- The increased time constants for reaching steady-state are a result of the slow activation of additional nucleation sites following boiling inversion

CONCLUSIONS

- FLSP surfaces resulting in boiling inversion require longer times to reach steady-state once inversion has occurred
- Boiling inversion has been shown to be the result of changing nucleation dynamics in which a large number of nucleation sites activate
- Increased time required to reach steady-state is linked to the rate at which these nucleation sites activate
- Heat fluxes above the boiling inversion point can require up to an additional 3 hours to reach steady-state, compared to the typical 15-20 minutes reported in the literature

ACKNOWLEDGEMENTS

This work has been funded by the Office of Naval Research under contract #FA4600-12-D-9000-17-FU909.

FLSP PROCEDURE

- Surface is processed with a Ti:Sapphire femtosecond laser (Legend Elite Duo HE+)
- Different settings produce unique surfaces

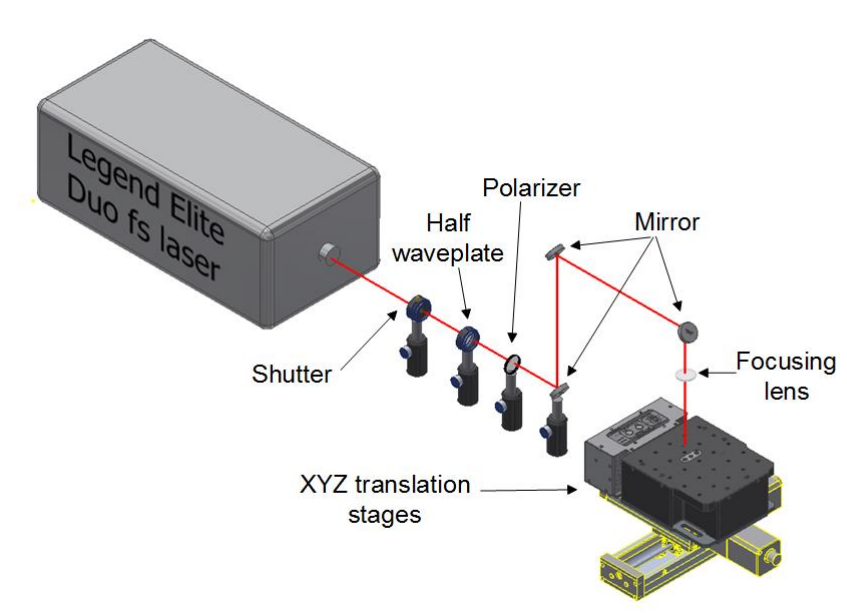

Fig. 2: Schematic of laser processing setup

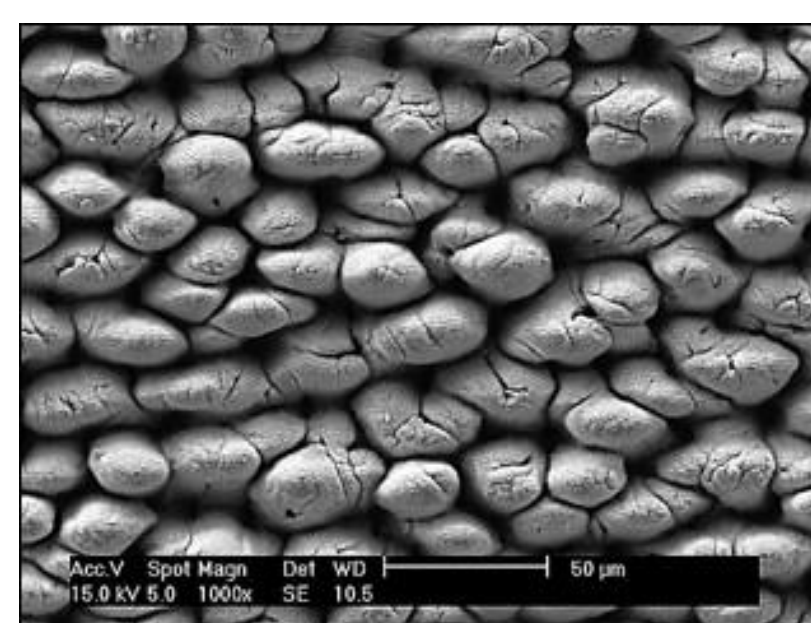

Fig. 3: SEM image taken normal to laser-formed structures

RESULTS

- A baseline curve was generated using the steady-state criterion and is shown in Fig. 5 (HF)
- Additional runs were done where a particular heat flux was chosen to allow for extended boiling times
- Heat fluxes of 25, 40, 60, and 70 W/cm² were chosen which corresponded to two points below the boiling inversion point and two above the boiling inversion point
- Heat fluxes below the inversion point showed no major change compared to baseline curve (Fig. 5)
- Heat fluxes above the inversion point showed significant temperature changes compared to the baseline curve (Fig. 6)