

See discussions, stats, and author profiles for this publication at: <https://www.researchgate.net/publication/330144256>

Mechanical Characterisation and Modelling of a Pulverised Palm Kernel Shell based Spur Gear

Conference Paper · November 2018

CITATIONS

0

READS

156

8 authors, including:



Olabisi Ibukun Adeyemi

Federal University of Petroleum Resources

12 PUBLICATIONS 70 CITATIONS

SEE PROFILE



Eyere Emagbetere

Federal University of Petroleum Resources

20 PUBLICATIONS 18 CITATIONS

SEE PROFILE



Benjamin Ufuoma Oreko

Federal University of Petroleum Resources

26 PUBLICATIONS 34 CITATIONS

SEE PROFILE



Abraham Kehinde

Covenant University Ota Ogun State, Nigeria

15 PUBLICATIONS 21 CITATIONS

SEE PROFILE

Some of the authors of this publication are also working on these related projects:



Current trends in Nano-research/Nanotechnology [View project](#)



Cost Optimization of Dual Source Multi-Destination Outbound System using Artificial Neural Network [View project](#)

Mechanical Characterisation and Modelling of a Pulverised Palm Kernel Shell based Spur Gear

Olabisi I. Adeyemi, Eyere Emagbetere and Ufuoma B. Oreko

Department of Mechanical Engineering
Federal University of Petroleum Resources,
Effurun, Nigeria

adeyemi.olabisi@fupre.edu.ng, emagbetere.eyere@fupre.edu.ng, oreko.benjamin@fupre.edu.ng

Aworinde Abraham Kehinde, Adeosun Samson Oluropo, Oyawale Adekunle Festus, Ishola Felix Adedayo and Ajayi Oluseyi. O.

Department of Mechanical Engineering
Covenant University
Ota, Nigeria

abraham.aworinde@covenantuniversity.edu.ng, samson.adeosun@covenantuniversity.edu.ng
festus.oyawale@covenantuniversity.edu.ng, felix.ishola@covenantuniversity.edu.ng,
oluseyi.ajayi@covenantuniversity.edu.ng

Abstract

Advances in power transmission using spur gear technology in some specific mechanical devices required lightweight to strength ratio of the gear material. This study evaluated the mechanical properties of a particulate palm kernel shell reinforced polyester composite (PPKSRPC) for spur gear application. The PPKSRPC sample was prepared and examined experimentally to determine its mechanical properties such as tensile strength, modulus of elasticity and shear modulus. The experimental result for 5% weight fraction of PPKSRPC gave a tensile strength, modulus of elasticity and shear modulus of 90.3 MPa, 2.35 GPa and 0.89 GPa, respectively. The value obtained was used to model the PPKSRPC spur gear under a torque of 140 N-m in ANSYS environment. The observed values of the responses (mechanical properties) of the PPKSRPC under loading conditions are lower compared to the conventional steel in spur gear application.

Keywords

Mechanical properties, Particulate palm kernel shell, Polyester, Spur gear

1. Introduction

The high strength to weight ratio and socio-economic benefits of natural fibre based composites make them suitable for many applications such as in polymer gears, vehicles interior and exterior components. More so, global quest for eco-friendly materials has sparked research interests into the development and use of natural composites. Some applications and advantageous properties of different natural composites have been reported in the literature (Sanjay, et al., 2017; Raju & Kumarappa, 2012; Rozman, et al., 2005; Razaka, et al., 2017; Kilanko, et al., 2018; Oreko, et al., 2018). A variety of agricultural residues ranging from soft banana peel to hard palm kernel shells (PKS) are being used to produce natural fibre based composites.

Palm fruit is widely cultivated in Nigeria (Poku, 2002). Palm Kernel Shell (PKS) is a by-product of palm fruit, and can be used as a natural reinforcement in the manufacture of polymer composites. Particulate PKS has surface elements and is crystalline. PKS has poor thermal conductivity and can serve as a thermal insulator (Ighodalo & Okoebor, 1996). It can be used for construction materials and water treatment granular filters (Okorogwe, et al., 2014; Oti, et al., 2017; Alsalami, et al., 2018). It has successfully been used to develop friction materials such as brake pads for automobiles (Fono-Tamoa & Koyab, 2017; Ikpambese, et al., 2016; Elakhame, et al., 2014; Ibadode & Dagwa,

2008). The characterisation of powder for use in polymer matrix composite has been reported (Dagwa, et al., 2012; Sanjay, et al., 2017). The size and percentage composition of PKS particles in the polymer composite and its effect on the mechanical and microstructural properties were also reported (Olumuyiwa, et al., 2012; Shehu, et al., 2014). Currently, composite materials are used to produce gears for pumps, motors, actuators, and drive shafts of automobiles (Rajeshkumar & Manoharan, 2017; Anakhu et al., 2018). The design of gears is well discussed in the literature (Hewitt 1992; Maitra 1994; Khurmi and Gupta 2005). Although there are several gear types, (Mahendran, et al., 2014) opined that spur gears are usually the first choice of gears due to their design simplicity, ease of manufacture, excellent efficiency and wide range of applicability. Parey & Tandon, 2003 reported some dynamic models of spur gears and their defects, while finite element analysis of static stress in spur gears was given in (Rajak & Kumar, 2016; Singh, et al., 2017). Gupta and Chatterjee applied finite element analysis to model the static stresses of spur gears of different plastic materials (Gupta & Chatterjee, 2018). They reported that the stress values were below the permissible stresses regardless of the material types.

Polymer composite gears have been reported to become soft and suffer wear as surface temperature increases (Mao, 2007). However, their low cost, low noise advantages can still be annexed if they are well reinforced. For example, polymer reinforced with Polycarbonate/Acrylonitrile-Butadiene-Styrene (PC/ABS), though having low load carrying capacity, has been found to have sufficient resistance to fire, ultraviolet light and moisture (Yakut, et al., 2009). Just like PC/ABS, PKS has a high carbon content, thus when blended with the polymer, may serve as a suitable material for the spur gear.

The aim of this study is to introduce a new area of application of PKS, particularly in the production of spur gears. Furthermore, advantage the use of such composites might have over the conventional spur gears made of cast steel was investigated. Particulate PKS reinforced Polyester Resin material was developed, its mechanical properties were investigated and used to model spur gears.

2. Materials and Method

2.1 Materials

The materials employed in this study include Palm Kernel Shells (PKS), unsaturated polyester resin; hardener or catalyst (methyl ethyl ketone peroxide); accelerator (cobalt naphthenate); release agent (A - Z grease); sodium hydroxide (NaOH); deionised water and the mould materials. The Particulate palm kernel shells act as the reinforcing materials and were obtained as waste materials from a palm kernel vendor at Effurun, Warri Delta state, Nigeria. Also, the polyester resin, catalyst (methyl-ethyl-ketone peroxide, MEKP), the accelerator (cobalt naphthenate) and other additives were purchased at Effurun market in Delta State, Nigeria.

2.1.1 The Mould

The mould was constructed to the required dimension of the tensile test specimen as shown in Figure 1, using PVC and silicon rubber.



Figure 1: The moulds (silicon rubber on PVC)

2.2 Method

The raw PKSs were cleaned to remove impurities (Figure 2a), crushed and ground into a fine powder known here as particulate palm kernel shell (PPKS) as shown in Figure 2b. The PPKS was treated by the mercerisation process, sundried and sieved (using a sieve of 850 μ m aperture).



Figure 2(a). Raw Palm Kernel Shells



Figure 2(b) Powdered PPKS

The average percentage weight composition of the particulate palm kernel shell reinforced Composites (PPKSRPC) with a weight fraction of 5% is shown in Table 1.

Table 1: Weight formulation of composites

S/N	Material	% Weight composition
1.	Polyester Resin + Hardener	94.98
2.	Accelerator	0.02
4.	Palm Kernel Shells Powder	5.00
	Total	100

2.3 Experimental Details

2.3.1 Tensile test

The tensile test experiment on PPKSRPC specimen with average gauge length 50mm and width 4mm, shown in Figure 3, was carried out using an electronic universal testing machine (Model: INSTRON 3369), at the Material Testing laboratories, Engineering Material Development Institute, EMDI, Akure, Nigeria.



Figure 3: Tensile test specimens.

2.3.2 Density Test

The PPKS based composite was sized accordingly, weighed and recorded as w (in grams), distilled water was poured into a measuring cylinder with initial volume recorded as V_1 (in cm^3). The weighed (dry) PPKSRPC was immersed

into the measuring cylinder containing distilled water, and the final volume recorded as V_2 (in cm^3). The density of the PPKSRPC was calculated using the expression (Abdul Khalil, 2011):

$$\frac{W}{V_1 - V_2} \times \text{grams/cm}^3$$

Where: w = weight of the dried PPKS sample (g); v_1 and v_2 are the initial and final volume of water, respectively (cm^3)

2.4 Performance Modelling

Static structural analysis on PPKSRPC for gear design was analysed and compared with the design on cast steel for spur gear application, developed by Mahendran et al., 2014. The geometric model of gear design was produced in solid works (Figures 4 and 5) and the model imported into ANSYS 15.0 and mesh was analysed (Figure 6). In the ANSYS environment, the connection types, material properties were inputted and the material selected (Table 2). Also, the mesh and static structural properties, boundary conditions were defined (Table 3).

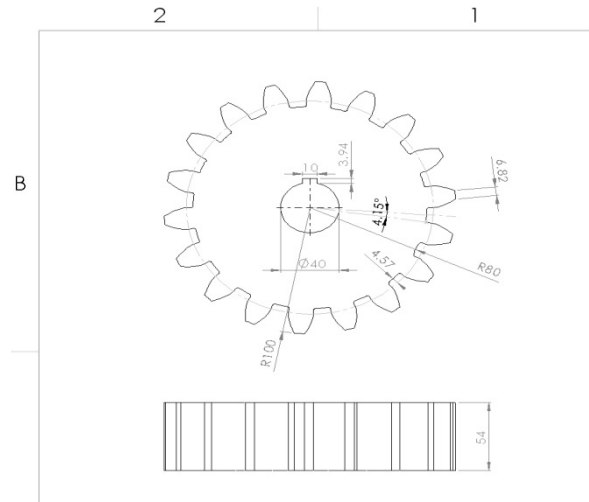

Figure 4: 2D drawing of spur gear



Figure 5: Solidworks Model

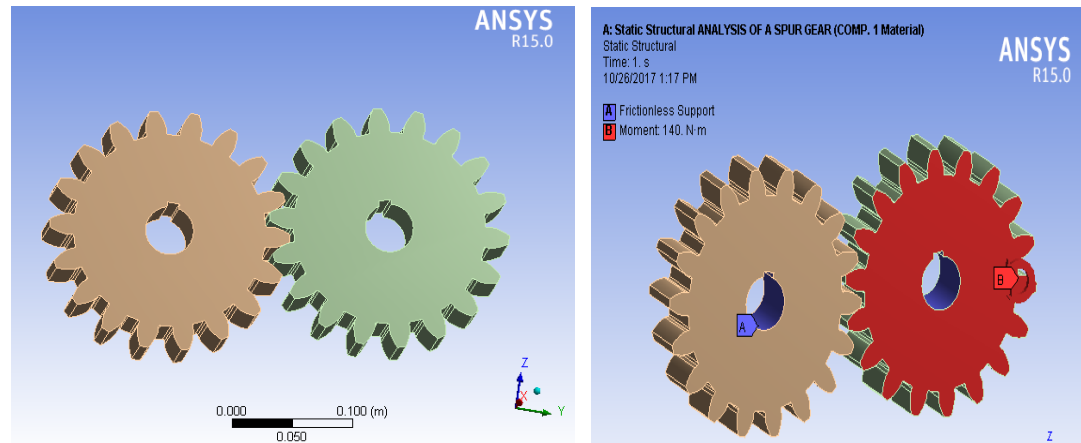

Figure 6: Model imported into ANSYS

Table 2: Connections

Model> Connections > Contacts	
Connection Type	Contact
Scope	
Scoping Method	Geometry Selection
Geometry	All Bodies

Table 3: Mesh

Model> Mesh	
Physics Preference	Mechanical
Relevance	0
Patch Conforming Options	
Triangle Surface Mesher	Program Controlled
Statistics	
Nodes	307761
Elements	189022
Mesh Metric	None

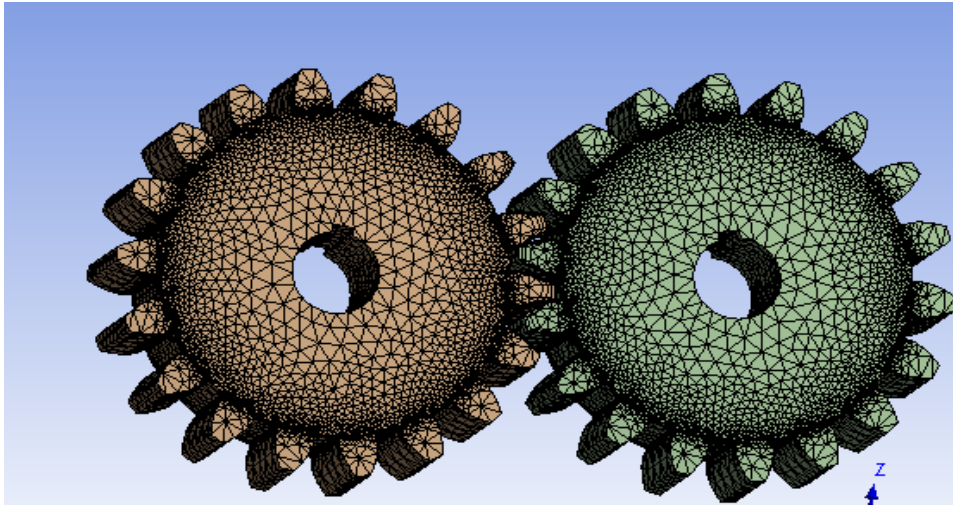

Figure 6. Analysis of Mesh in Ansys 15.0

3. Results and Discussion

3.1 Physical Properties of the Particulate Palm Kernel Shell

The following physical properties of the particulate palm kernel shell (PPKS) observed is shown in Table 4.

Table 4: Physical Properties of PPKS

Reinforcement Material	Diameter (μm)	Texture	Colour	Density
Palm Kernel Shells	850	Coarse	Dark Brown	0.846

3.2 Results for the Mechanical Properties of PPKSRPC

Table 5 is the average result of the tensile strength properties of PPKSRPC obtained. The stress-strain plot of the PPKSRPC is shown in Figure 7. At 90.3 MPa, failure of the PPKSRPC sample was observed.

Table 5: Tensile Strength Properties Results

Material/ Composition	Average Load at break (N)	Average Extension at break (mm)	Average Tensile stress at break (MPa)	Average Tensile strain at break (mm/mm)	Average Modulus (MPa)
PPKSRC	1083.53	2.92	90.30	0.058	2354.25

Tensile Ultimate Strength (MPa)	Young's Modulus (GPa)	Poisson's Ratio	Bulk Modulus (GPa)	Shear Modulus (GPa)	Density (kg/m^3)
90.29	2.3543	0.33	2.3081	0.89	846

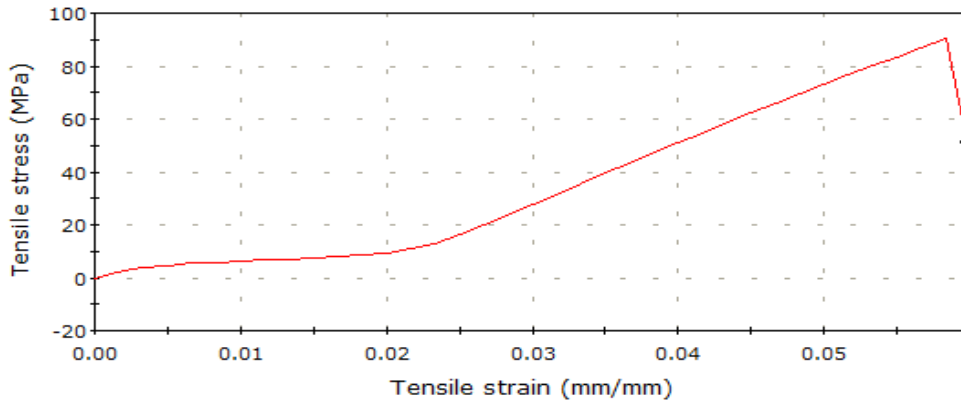

Figure 7. Stress-Strain Plot of PPKSRC

The tensile strength obtained from the PPKSRPC was 90.3MPa. This value is lower than the tensile strength of Cast steel of 540 MPa used for the design of spur gear by Mahendran et al., 2014. However, the tensile strength of PPKSRPC obtained can be used for the designed and development of spur gear where its application requires maximum loading condition less than 90.3 MPa.

3.3 Modelling of PPKSRPC Spur Gear

With a torque of 140N-m, the PPKSRPC spur gear was modelled, the von-mises stress distribution and elastic strain are shown in Figure 8. It can be observe that the values of stresses and strain are minimal and well distributed around the modeled spur gear. However, stresses are higher around the keyway due to stress concentration effect. Figure 9 shows the total deformation of the shear stress of the modelled spur gear. Deformations are higher around the teeth areas of the modeled spur gear. As such, proper clearance should be given when designing spur gears made of PKS polyester resin composites. The maximum von-mises stress and shear stresses for both the developed material model and that of steel are shown in Figure 10. The von-misses stresses and maximum shear stress of the developed material compare favourably with those of steel material. The maximum Von-misses stress of the modeled spur gear (5.00 MPa) is however lower than the value of yield stress (90.0 MPa) obtained during the uniaxial test of the PKS composite. Therefore, spur gears developed with the PKS composite are not likely to fail under the design conditions.

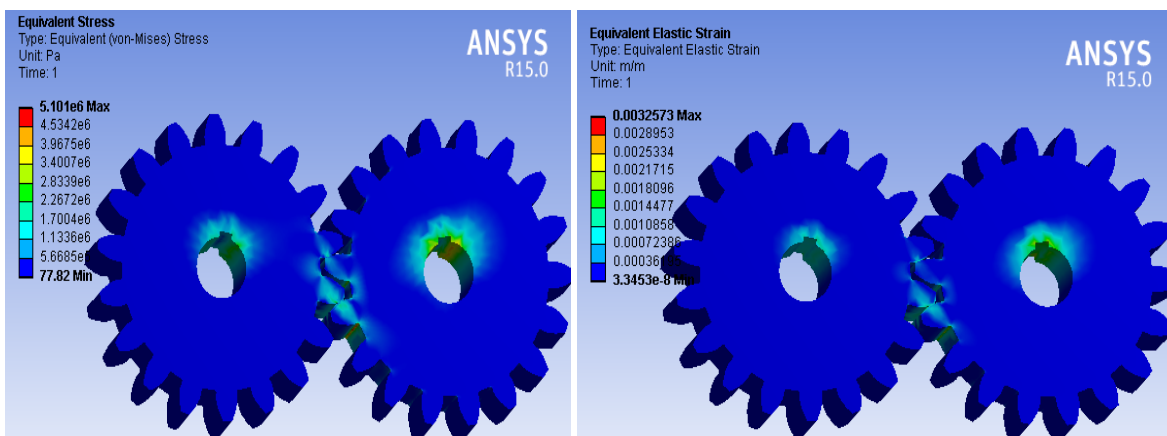

Figure 8. Von-Mises Stress Distribution and Elastic Strain of PPKSRPC Spur Gear

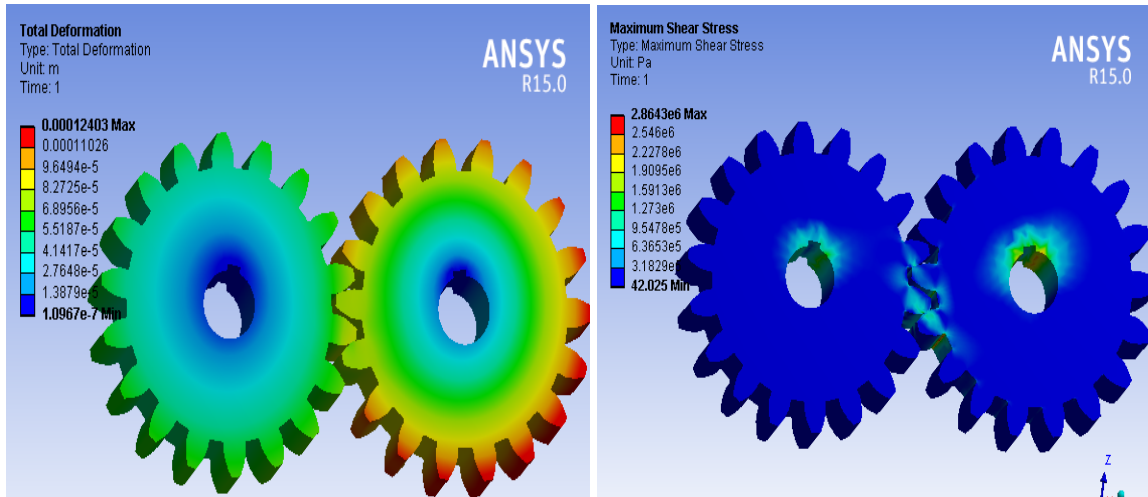

Figure 9. Total Deformation Maximum Shear Stress of PPKSRPC Spur Gear

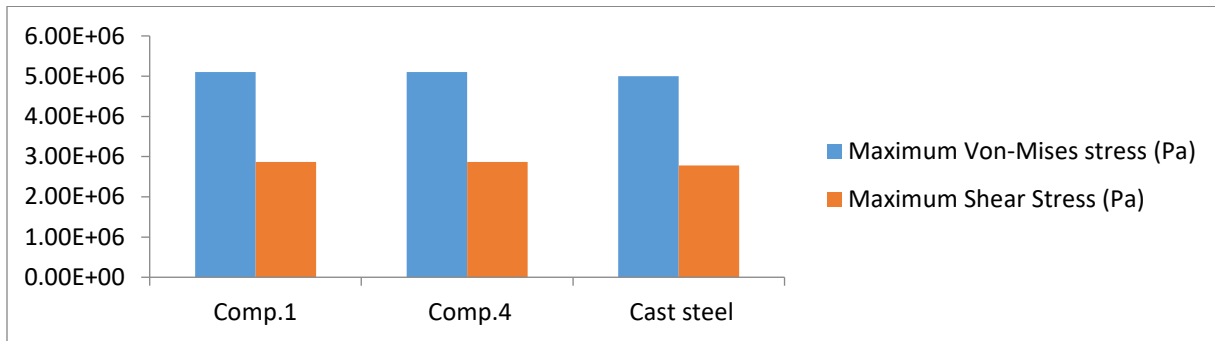

Figure 10. Stresses in PPKSRPC spur gear.

Conclusion

In this work, particulate palm kernel shells reinforced polymer composite PPKSRPC was experimentally and analytically studied. The developed composites were investigated by determining their physical and mechanical properties. Their static structural performance in spur gears was analysed and modelled. The results obtained for a 5% weight fraction for PPKSRPC indicated that it could perform well in gear application where loading condition and torque requirement is less than 90.3 MPa and 140 N-m.

Acknowledgements: We gratefully thank Covenant University, Ota, Nigeria for financial support.

References

- Alsalamy, Z. H., Harith, I. K., and Dhahir, M. K. Utilization of Dates Palm Kernel in High Performance Concrete. *Journal of Building Engineering*. 2018
- Anakhu, P. I., Abioye, A. A., Bolu, C. A., and Azeta, J. Modelling of the Kinetic Geometry of Spur Gears Using MATLAB. *MATEC WEB OF Conference*, 153. 2018.
- Dagwa, I. M., Builders, P. F., and Achebo, J. Characterization Of Palm Kernel Shell Powder For Use In Polymer Composite Matrix. *International Journal of Mechanical & Mechatronics Engineering*, 12(4), 88-93. 2012.
- Elakhame, Z. U., Alhassan, O. A., and Samuel, A. E. Development and Production of Brake Pads from palm Kernel Shell composites. *International Journal of Scientific & Engineering Research*, 5(10), 735-744. 2014.
- Fono-Tamoa, R. S., and Koyab, O. Influence of Palm Kernel Shell Particle Size on Fade and Recovery Behaviour of Non-asbestos Organic Friction Material. *Pocedia Manufacturing*, 7, 440-451. 2017.
- Guptaa, K., and Chatterjeeb, S. Analysis of Design and Material Selection of a Spur gear pair for Solar Tracking Application. *Materials Today: Proceedings* 5, 789–795. 2018.
- Hewitt, J. Design and Materials selection for Power-transmitting gears. *Materials and Design*, 13(4), 230-238. 1992.

- IbhadodeI, A. O., and Dagwa, I. M. Development of asbestos-free friction lining material from palm kernel shell. *Journal of Brazillian Society of Mechanical Sciences and Engineering*, 30(2), 1806-3691. 2008.
- Ighodalo, O. A., and Okoebor, W. J. Thermal conductivity of some local waste materials Rice husk, Palm kernel shells and wood shavings. *NSE Technical Transactions*, 31(3), 68-73. 1996.
- Ikpambese, K. K., Gundu, D. T., and Tuleun, L. T. Evaluation of palm kernel fibers (PKFs) for production of asbestos-free automotive brake pads. *Journal of King Saud University - Engineering Sciences*, 28(1), 110-118. 2016.
- Khurmi, R. S., and Gupta, J. K. *A textbook of Machine Design*. New Delhi: EURASIA PUBLISHING HOUSE (PVT.) LTD. 1021-1065. 2005.
- Kilanko, O., Ojolo, S. J., Inegbenebor, A. O., Ilori, T. A., Leramo, R. O., Babalola, P. O., and Oyedepo S. O. "Design and performance evaluation of centrifugal cashew nut sheller for improving the whole kernel recovery." *Agricultural Engineering International*, 20(1), 162-170. 2018.
- Mahendran, S., Eazhil, K. M., and Kumar, L. S. Design and Analysis of Composite Spur Gear. *IJRSI*, 1(6), 42-53. 2014.
- Maitra G. M.. *Handbook of Gear Design, Second Edition*. New Delhi: Tata McGrawHill Publishing Company Limited. 1994.
- Mao, K. A new approach for polymer composite gear design. *Wear*, 262, 432-441. 2007.
- Okorogwe, C. E., saffron, C. M., and Kamdem, P. D. Characterization of of palm kernel Shell for material reinforcement and water treatment. *Journal of Chemical Engineering and materials science*, 5(2), 1-6. 2014.
- Olumuyiwa, A. J., Isaac, T. S., Adewunmi, O. A., and Olofade, A. I. Effects of Palm Kernel Shell on the Microstructure and Mechanical Properties of Recycled Polyethylene/Palm Kernel Shell Particulate Composites. *Journal of Minerals and Materials Characterization and Engineering*, 11, 825-831. 2012.
- Oreko, B. U., Otanocha, O. B., Emagbetere, E., and Ihueze, C. Analysis and Application of Natural Fiber Reinforced Polyester Composite to Automobile Fender. *Convenant Journal of Engineering Technology*, 1(1), 1-12. 2018.
- Oti, O. P., Nwagwe, K. N., and Okereke, N. A. Assessment of palm kernel shell as a composite aggregate in concrete. *Agricultural Engineering International: CIGR Journal*, 19(2), 34--41. 2017.
- Parey, A., and Tandon, N. Spur gear dynamic models including defects: A review. *The Shock and Vibration Digest*, 35(6), pp. 465-478. 2003..
- Poku, K. *Small-Scale Palm Oil Processing in Africa*. Rome: Fao Agricultural Services Bulletin. ISBN: 92-5-104859-2. 2002.
- Rajak, S., and Kumar, V. Finite Element Analysis of Spur Gear: A review. *International Journal of Engineering Technology and management research*, 160-166. ISSN: 2320-5288. 2016.
- Rajeshkumar, S., and Manoharan, R. Design and analysis of composite spur gears using finite element method. *IOP Conference Series: Materials Science and Engineering*, 263. 1-8. 2017.
- Raju, G. U., and Kumarappa, S. Mechanical and physical characterization of agricultural waste reinforced polymer composites. *J. Mater. Environ. Sci*, 3(5), 907-916. 2012.
- Razaka, M. F., Bakar, M. A., Kasolang, S., and Ahmadd, M. A. The Effect of Fiber Treatment on Abrasive Wear Properties of Palm Fiber Reinforced Epoxy Composite. *AIP Conference Proceedings, American Institute of Physics*, 1901(1), 1-6. 2017.
- Rozman, D., Zainal, A., and Umaru, S. *Natural Fibres, Biopolymers, and Biocomposites: Oil Palm Fiber-Thermo-composites*. Boca Raton: CRC Press. 1-36. 2005.
- Sanjay, M. R., Madhu, P., Jawaid, M., Senthamaraiannan, P., Senthil, S., and Pradeep, S. Characterization and Properties of Natural Fiber Polymer Composites: A Comprehensive Review. *Journal of Cleaner Production*, 172. 566-581. 2017.
- Shehu U., Aponbiede O., Ause T., and Obiodunukwe E. F. *J. Mater. Environ. Sci.*, 5(2), 366-373. 2014.
- Singh, A. K., Siddhartha, and Singh, P. K. Polymer Spur gears behaviours under different loading conditions: A review. *Proceedings of the Institution of Mechanical Engineers, partJ: . SAGE JOURNALS: Journal of Engineering Tribology*, 232(2). 210-228. 2017.
- Tian, W., Qi, L., Su, C., Zhou, J., and Jing, Z. Numerical Simulation on Elastic properties of short-fibre-reinforced metal matrix composites: effect of fibre orientation *Compos. Struct* 152. 408-417. 2016.
- Yakut, R., Düzçükoğlu, H., and Demirci, M. T. The load capacity of PC/ABS spur gears and investigation of gear damage. *Archives of Material Science and Engineering*, 40(1), 41-46. 2009.

Biographies

Olabisi I. Adeyemi specialises in sustainable materials and manufacturing with a specific research interest in bio-based PMCs development, assessment and analysis. He is a full-time academic staff of the Department of Mechanical

Engineering, Federal University of Petroleum Resources, Effurun, Nigeria, and currently undertaking his PhD study at the University of Warwick, United Kingdom.

Aworinde K. Abraham is a full-time lecturer and PhD student in the Department of Mechanical Engineering, Covenant University, Ota, Ogun State, Nigeria. His research interest is in the area of Fracture Mechanics. He is currently working on the fracture behavior of biodegradable reinforced polymer for orthopedic applications.

Eyere Emagbetere is currently a full-time lecturer in the Department of Mechanical Engineering, Federal University of Petroleum Resources, Effurun, Nigeria. He holds a PhD degree in mechanical engineering from the University of Ibadan. His research areas include numerical simulation, modelling and mechanics.

Samson Oluropo Adeosun is a full professor of Metallurgical and Materials Engineering in the Department of Metallurgical and Materials Engineering, University of Lagos, Nigeria. His works are in the area of materials development, processing and characterization.

Benjamin U. Oreko is currently a full-time lecturer in the Department of Mechanical Engineering, Federal University of Petroleum Resources, Effurun, Nigeria. He holds a PhD degree in mechanical engineering from the University of Benin, Nigeria. He is an expert in materials development.

Oyawale A. Festus is a full professor of Mechanical Engineering in the Department of Mechanical Engineering, Covenant University, Ota, Ogun State, Nigeria. His research area is design and production.

Felix A. Ishola is a full-time lecturer and PhD student in the Department of Mechanical Engineering, Covenant University, Ota, Ogun State, Nigeria. His research interests are Risk Analysis, Waste Management, Materials development, Design and Modelling. He is currently working on waste tyre to produce graphite for electrode production.

Ajayi O. Oluseyi is a full time professor in the Department of Mechanical Engineering, Covenant University, Ota, Ogun State, Nigeria. His research interest is in Thermo-fluids and Renewable Energy Systems. He has also worked extensively in the area of Design and Production Technology.