

The Neutron Time-Of-Flight Facility n_TOF At CERN: Phase II

Cite as: AIP Conference Proceedings **1336**, 547 (2011); <https://doi.org/10.1063/1.3586160>
Published Online: 14 June 2011

F. Gunsing, S. Andriamonje, J. Andrzejewski, L. Audouin, V. Bécaries, F. Bečvář, F. Belloni, B. Berthier, E. Berthoumieux, M. Brugger, M. Calviani, F. Calviño, D. Cano-Ott, C. Carrapiço, P. Cennini, F. Cerutti, E. Chiaveri, M. Chin, N. Colonna, G. Cortés, M. A. Cortés-Giraldo, I. Dillmann, C. Domingo-Pardo, I. Duran, M. Fernández-Ordóñez, A. Ferrari, K. Fraval, S. Ganesan, I. Giomataris, G. Giubrone, M. B. Gómez-Hornillos, I. F. Gonçalves, E. González-Romero, F. Gramegna, C. Guerrero, S. Harrisopulos, M. Heil, K. Ioannides, E. Jericha, Y. Kadi, F. Käppeler, D. Karadimos, M. Krťička, E. Lebbos, C. Lederer, H. Leeb, R. Losito, M. Lozano, J. Marganec, S. Marrone, T. Martinez, C. Massimi, P. F. Mastinu, M. Meaze, E. Mendoza, A. Mengoni, P. M. Milazzo, M. Mosconi, R. Nolte, T. Papaevangelou, C. Paradela, A. Pavlik, J. Perkowski, R. Plag, J. Praena, J. M. Quesada, T. Rauscher, R. Reifarth, F. Roman, C. Rubbia, R. Sarmiento, G. Tagliente, J. L. Tain, D. Tarrío, L. Tassan-Got, L. Tlustos, G. Vannini, V. Variale, P. Vaz, A. Ventura, V. Vlachoudis, R. Vlastou, Z. Vykydal, A. Wallner, C. Weiß, and The n_TOF Collaboration



View Online



Export Citation

ARTICLES YOU MAY BE INTERESTED IN

[Neutron research at the N_TOF facility \(CERN\): Results and perspectives](#)

AIP Conference Proceedings **1525**, 570 (2013); <https://doi.org/10.1063/1.4802393>

[The \$^{237}\text{Np}\(n,f\)\$ cross section at the CERN n-TOF facility](#)

AIP Conference Proceedings **1377**, 459 (2011); <https://doi.org/10.1063/1.3628445>

[The n_TOF Total Absorption Calorimeter response to \$\gamma\$ -ray cascades following neutron capture in minor actinides](#)

AIP Conference Proceedings **1090**, 372 (2009); <https://doi.org/10.1063/1.3087048>

Lock-in Amplifiers
up to 600 MHz



The Neutron Time-Of-Flight Facility n_TOF At CERN: Phase II

F. Gunsing¹⁾, S. Andriamonje²⁾, J. Andrzejewski³⁾, L. Audouin⁴⁾, V. Bécaries⁵⁾,
F. Bečvář⁶⁾, F. Belloni¹⁾, B. Berthier⁴⁾, E. Berthoumieux¹⁾, M. Brugger²⁾,
M. Calviani²⁾, F. Calviño⁷⁾, D. Cano-Ott⁵⁾, C. Carrapiço⁸⁾, P. Cennini²⁾, F. Cerutti²⁾,
E. Chiaveri²⁾, M. Chin²⁾, N. Colonna⁹⁾, G. Cortés⁷⁾, M.A. Cortés-Giraldo¹⁰⁾,
I. Dillmann¹¹⁾, C. Domingo-Pardo¹²⁾, I. Duran¹³⁾, M. Fernández-Ordóñez⁵⁾,
A. Ferrari²⁾, K. Fraval¹⁾, S. Ganesan¹⁴⁾, I. Giomataris¹⁾, G. Giubrone¹⁵⁾,
M.B. Gómez-Hornillos⁷⁾, I.F. Gonçalves⁸⁾, E. González-Romero⁵⁾, F. Gramegna¹⁶⁾,
C. Guerrero⁵⁾, S. Harrisopulos¹⁷⁾, M. Heil¹²⁾, K. Ioannides¹⁸⁾, E. Jericha¹⁹⁾,
Y. Kadi²⁾, F. Käppeler²⁰⁾, D. Karadimos¹⁸⁾, M. Krtička⁶⁾, E. Lebbos²⁾, C. Lederer²¹⁾,
H. Leeb¹⁹⁾, R. Losito²⁾, M. Lozano¹⁰⁾, J. Marganec³⁾, S. Marrone⁹⁾, T. Martinez⁵⁾,
C. Massimi²²⁾, P.F. Mastinu¹⁶⁾, M. Meaze⁹⁾, E. Mendoza⁵⁾, A. Mengoni²³⁾,
P.M. Milazzo²⁴⁾, M. Mosconi²⁵⁾, R. Nolte²⁵⁾, T. Papaevangelou¹⁾, C. Paradela¹³⁾,
A. Pavlik²¹⁾, J. Perkowski³⁾, R. Plag¹²⁾, J. Praena¹⁰⁾, J.M. Quesada¹⁰⁾, T. Rauscher²⁶⁾,
R. Reifarth¹²⁾, F. Roman^{2,27)}, C. Rubbia^{2,28)}, R. Sarmiento⁸⁾, G. Tagliente⁹⁾,
J.L. Tain¹⁵⁾, D. Tarrío¹³⁾, L. Tassan-Got⁴⁾, L. Tlustos²⁾, G. Vannini²²⁾, V. Variale⁹⁾,
P. Vaz⁸⁾, A. Ventura²³⁾, V. Vlachoudis²⁾, R. Vlastou²⁹⁾, Z. Vykydal³⁰⁾, A. Wallner²¹⁾,
C. Weiß¹⁹⁾, The n_TOF Collaboration (<http://www.cern.ch/ntof>)

¹⁾ CEA, Irfu, F-91191 Gif-sur-Yvette, France

²⁾ European Organization for Nuclear Research (CERN), Geneva, Switzerland

³⁾ Uniwersytet Łódzki, Lodz, Poland

⁴⁾ Centre National de la Recherche Scientifique/IN2P3 - IPN, Orsay, France

⁵⁾ Centro de Investigaciones Energeticas Medioambientales y Technologicas (CIEMAT), Madrid, Spain

⁶⁾ Charles University, Prague, Czech Republic

⁷⁾ Universitat Politecnica de Catalunya, Barcelona, Spain

⁸⁾ Instituto Tecnológico e Nuclear (ITN), Lisbon, Portugal

⁹⁾ Istituto Nazionale di Fisica Nucleare, Bari, Italy

¹⁰⁾ Universidad de Sevilla, Spain

¹¹⁾ Physik Department E12 and Excellence Cluster Universe, Technische Universität München, Garching, Germany

¹²⁾ GSI Helmholtzzentrum für Schwerionenforschung GmbH, Darmstadt, Germany

¹³⁾ Universidade de Santiago de Compostela, Spain

¹⁴⁾ Bhabha Atomic Research Centre (BARC), Mumbai, India

¹⁵⁾ Instituto de Física Corpuscular, CSIC-Universidad de Valencia, Spain

¹⁶⁾ Istituto Nazionale di Fisica Nucleare, Laboratori Nazionali di Legnaro, Italy

¹⁷⁾ National Centre of Scientific Research (NCSR), Demokritos, Greece

¹⁸⁾ University of Ioannina, Greece

¹⁹⁾ Atominstytut, Technische Universität Wien, Austria

²⁰⁾ Karlsruhe Institute of Technology, Campus Nord, Institut für Kernphysik, Karlsruhe, Germany

²¹⁾ Fakultät für Physik, Universität Wien, Austria

- ²²⁾ *Dipartimento di Fisica, Università di Bologna, and Sezione INFN di Bologna, Italy*
- ²³⁾ *Agenzia nazionale per le nuove tecnologie, l'energia e lo sviluppo economico sostenibile (ENEA), Bologna, Italy*
- ²⁴⁾ *Istituto Nazionale di Fisica Nucleare, Trieste, Italy*
- ²⁵⁾ *Physikalisch-Technische Bundesanstalt (PTB), Braunschweig, Germany*
- ²⁶⁾ *Department of Physics and Astronomy - University of Basel, Basel, Switzerland*
- ²⁷⁾ *Horia Hulubei National Institute of Physics and Nuclear Engineering - IFIN HH, Bucharest - Magurele, Romania*
- ²⁸⁾ *Laboratori Nazionali del Gran Sasso dell'INFN, Assergi (AQ), Italy*
- ²⁹⁾ *National Technical University of Athens (NTUA), Greece*
- ³⁰⁾ *Institute of Experimental and Applied Physic (IEAP), Czech Technical University (CTU), Prague, Czech Republic*

Abstract. Neutron-induced reactions are studied at the neutron time-of-flight facility n_TOF at CERN. The facility uses 6-ns wide pulses of 20 GeV/c protons impinging on a lead spallation target. The large neutron energy range and the high instantaneous neutron flux combined with high resolution are among the key characteristics of the facility. After a first phase of data taking during the period 2001-2004, the facility has been refurbished with an upgraded spallation target and cooling system for a second phase of data taking which started in 2009. Since 2010, the experimental area at 185 m where the neutron beam arrives, has been modified into a worksector of type A, allowing the extension of the physics program to include neutron-induced reactions on radioactive isotopes.

Keywords: n_TOF, CERN, neutrons, neutron induced reactions, neutron time-of-flight facility

PACS: 21.10.Ma, 25.40.Ny, 25.85.Ec, 28.20.Np, 28.20.Pr, 29.25.Dz

INTRODUCTION

The neutron time-of-flight facility n_TOF at CERN provides a pulsed neutron beam of high intensity, with neutron energies ranging from the meV to the GeV range. Neutron induced nuclear reactions are studied in this energy range, mainly neutron capture and neutron-induced fission reactions. Neutron-induced nuclear reactions play an important role in several research fields. In nuclear structure studies the neutron may serve as probe of excited nuclei revealing separate highly excited levels just above the neutron binding energy, which allows to derive an important calibration point in level densities [1,2]. In astrophysics the formation of the vast majority of all known nuclei with masses heavier than iron are formed in stellar environments mainly through slow and rapid neutron capture processes. Neutron-nucleus reaction data are an essential ingredient to calculate production rates in stellar nucleo-synthesis and refine the understanding of stellar evolution processes [3,4]. Finally neutron-induced reactions, or nuclear data in general, play a key role in the safety and criticality assessment of nuclear technology, not only for existing power reactors but also for radiation dosimetry, the transmutation of nuclear waste, alternative reactor fuel cycles, or future reactors like Generation IV [5,6].

Efforts concerning nuclear data have been ongoing since the early 50's and are growing since a decade or so, related to the renewed interest in new power reactors, and concern both reaction modeling and

evaluation activities as well as nuclear data measurements and facilities. In this perspective the construction and commissioning of the neutron time-of-flight facility at CERN, Switzerland, after an initial proposal of Rubbia [7], was finished in 2001 when the facility became operational [8]. After a first phase of data taking from 2001-2004, the facility was obliged to stop for a refurbishment of the spallation target. Since the end of 2008 the facility has resumed operation and a new program of measurements was launched in 2009. Since 2010 the facility's experimental area, located at 185 m from the neutron production target, has been modified in order to comply with radioprotection regulations into what is called a worksector of type A, allowing the use of radioactive samples in the neutron beam.

THE NEUTRON TIME-OF-FLIGHT FACILITY N_TOF AT CERN

The facility uses a 6 ns wide, 20 GeV/c proton beam with up to 7×10^{12} protons per pulse, impinging on a lead spallation target, and yielding about 300 neutrons per incident proton. The time between proton pulses is an integer multiple of 1.2 seconds which allows to cover the neutron energy range down to subthermal energies without overlapping of slow neutrons in subsequent cycles. A water layer surrounding the upgraded spallation target serves as a coolant. This layer is 1 cm thick on the side of the neutron beam guide. An additional layer of 4 cm of

water, separated from the cooling circuit, is placed in front of the cooling layer and acts as a moderator. The moderator can be optionally changed to a different material. In 2010 we have used for example water with a saturated, thus constant, ^{10}B -solution in order to reduce the number of 2.23 MeV gamma rays from hydrogen capture which otherwise constitutes an important contribution to the background due to in-beam gamma rays. This influences the energy distribution of the neutron flux only noticeably below 1 eV. The spallation target was a block of $80 \times 80 \times 60 \text{ cm}^3$ in the first phase, and was replaced by a cylindrical lead target of 40 cm diameter and 60 cm length for the second phase. A schematic view of the

new spallation target is shown in figure 1. In addition a new ventilation system was installed and a new target cooling circuit was developed. This allows among others to monitor and control the temperature, oxygen content and conductivity of the water.

From the lead spallation target, an evacuated neutron beam tube leads to the experimental area located at 185 m from the spallation target. A 1.5 T sweeping magnet is placed at a distance of 145 m to remove residual charged particles from the neutron beam. A 3 m thick off-beam iron shielding was placed just after the magnet to remove negative muons. A first collimator with an inner diameter of 11 cm is placed at 135 m while a second collimator with a

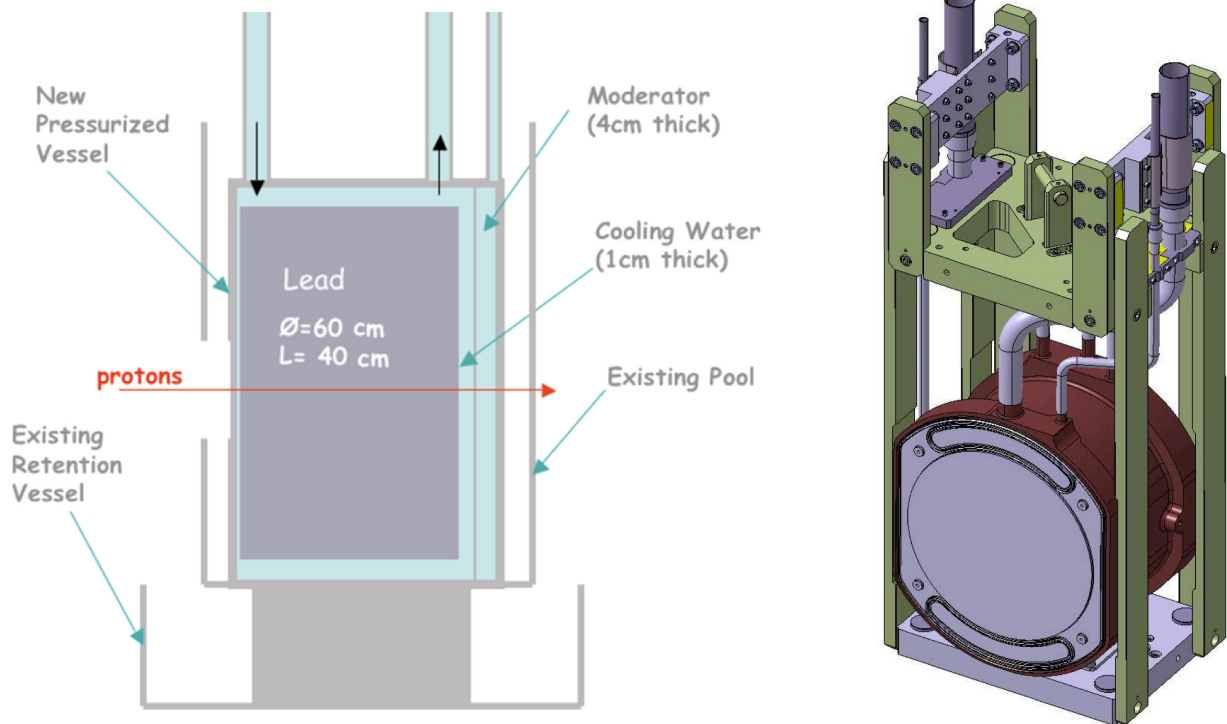

FIGURE 1. A schematic view of the upgraded lead spallation target as installed for the n_TOF facility.

variable diameter of either 1.8 or 8 cm is situated at 175 m from the production target. This collimation results in a Gaussian beam profile in the experimental area at 185 m. The neutron beam line has been extended for an additional 12 m beyond the experimental area to minimize the background from back-scattered neutrons. For the 1.8 cm second collimator the Gaussian profile was simulated and measured and has a standard deviation of 0.77 cm. At present the facility is mainly used for capture and fission measurements. A full description of the characteristics and performances of the facility is described elsewhere [9]. The neutron beam

characteristics in terms of energy distribution of the neutron flux and the energy resolution have been accurately determined by a combination of simulations and measurements.

DETECTORS AND EQUIPMENT

For the capture measurements two different detector systems are being used. In-house developed deuterated benzene C_6D_6 -based gamma-ray detectors contained in a cylindrical low mass carbon fibre housing [10] are used as total energy detectors. In addition a total absorption calorimeter consisting of a

4π array with 40 BaF₂ crystals is also used for capture measurements [11].

Fission experiments have been performed with two different detector systems in the first phase. Two fission ionization chambers (FIC) used deposits of fissile isotopes on 100 μm thick aluminum foils [12]. The second type of fission detector is based on parallel plate avalanche counters (PPACs) [13], developed with target deposits on 1.5 μm thin mylar or 2 μm thick aluminium foils, allowing to detect the two fission fragments in coincidence. This detector will be used also in phase II. A third type of fission detector, based on the MicroMegas principle, is currently being developed [14].

The energy distribution of the relative incident neutron flux is continuously measured during the experiments with a neutron flux monitor SiMon [15], consisting of a ⁶Li deposit on a mylar foil and 4 off-beam silicon detectors recording the particles from the standard ⁶Li(n,³H) α cross section. An additional transparent in-beam flux detector has been developed to overcome difficult angular distribution corrections needed above 1 keV for the SiMon detector. The new gaseous detector is based on standard cross sections like ²³⁵U(n,f) and ¹⁰B(n, α)⁶Li and combines thin deposits with 25 μm thin MicroMegas-based detectors.

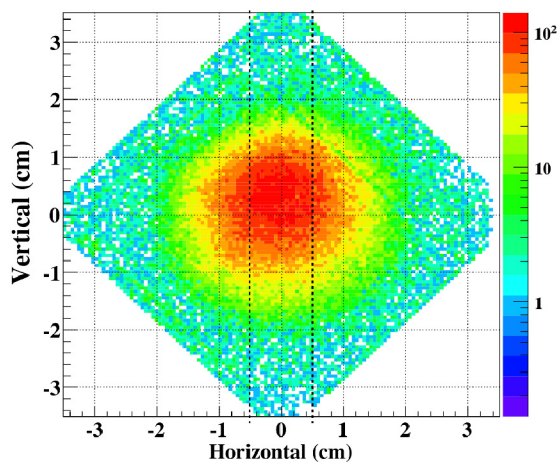

FIGURE 2. An example of a beam image obtained with the XY-MicroMegas detector, representing the spatial image of the neutron beam intensity. Images can be reconstructed as a function of the neutron time-of-flight.

In a dedicated experiment the spatial beam profile has been measured with two different devices. We have used a Medipix detector [16] with LiF and polyethylene converters to measure the distribution of the neutrons across the beam area. We also used a two dimensional MicroMegas-based detector with 106 x 106 perpendicular strips on a 6 x 6 cm² active area to

determine the beam profile with a resolution of about 0.5 x 0.5 mm² [17]. In figure 2 the image of the beam, which can be obtained as a function of time-of-flight, is shown as an example and in figure 3 a typical reaction chamber containing MicroMegas detectors is shown.

The data acquisition system [18] is based on Acqiris flash ADCs with 8 or 16 Mb memory, 8 bit or 10 bit amplitude resolution, and a minimum sampling interval of 1 ns. For each detector its full signal is recorded, starting from time the incident protons create the neutrons up to 8 or 16 ms, allowing to go in energy down to the thermal region. After zero suppression the detector signals for each event are transferred for permanent storage to CERN's data storage facility CASTOR. With dedicated pulse shape analysis routines the time-of-flight and signal amplitude is extracted from the signals of each detector event and recorded for further analysis.

MEASUREMENTS

During the first phase from 2001 to 2004 capture and fission data for a large number of isotopes have been taken. Capture measurements with the C₆D₆ detectors concerned ^{24,25,26}Mg, ⁵⁶Fe, ^{90,91,92,93,94,96}Zr,

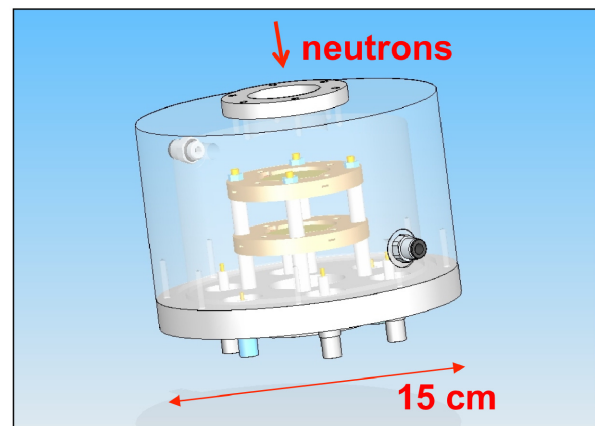

FIGURE 3. A schematic view of a reaction chamber, here equipped with two MicroMegas detectors.

¹³⁹La, ¹⁵¹Sm, ^{186,187,188}Os, ¹⁹⁷Au, ^{204,206,207,208}Pb, ²⁰⁹Bi, and ²³²Th. The BaF₂ 4π calorimeter has been used for measurements of ¹⁹⁷Au, ²³³U, ²³⁴U, and ²³⁷Np, ²⁴⁰Pu, and ²⁴³Am. The fission cross sections measured with the FIC-0 detector were the isotopes ²³²Th, ²³⁴U, ²³⁵U, ²³⁶U, ²³⁸U, and ²³⁷Np, while the isotopes ²³³U, ²³⁵U, ²³⁸U ²⁴¹Am, ²⁴³Am, and ²⁴⁵Cm were measured in the ISO-2919 compliant FIC-1 detector. With the fission detectors based on Parallel Plate Avalanche Counters (PPACs) cross sections of ^{nat}Pb, ²⁰⁹Bi, ²³²Th, ²³⁷Np, ²³³U, ²³⁴U, ²³⁵U, ²³⁸U have been measured. The

analysis of most of these measurements is completed and the results have been published. The most up-to-date list of publications can be found on the n_TOF web site [19].

For the second phase a list of possible measurements has been established of which several have already been translated in accepted proposals and are ongoing. After a period of commissioning measurements in 2009, a program of capture measurements on the stable isotopes of Fe and Ni has been started and is at present ongoing. The primary interest for these nuclei is for stellar nucleo-synthesis but also as structure materials for nuclear technology. In addition, and as part of a contract within the 7th European Framework programme, capture measurements on ²⁴¹Am are currently ongoing and capture measurements on ²³⁸U are foreseen in the nearby future. Fission cross sections measurements are foreseen for ²⁴⁰Pu and ²⁴²Pu and also the measurement of the angular distribution of fission fragments of ²³²Th. A main challenge remains the measurement of capture in presence of fission. In this respect, a first development of a fission tagging detector based on a MicroMegas detector in combination with the 4 π BaF₂ total absorption calorimeter has been set up for a measurement. Finally, we intend to develop an alpha particle detector for a measurement of the ³³S(n, α) cross section. This pilot experiment is planned as an extension of the fission and capture experiments that have been performed up to now.

CONCLUDING REMARKS

The n_TOF facility at CERN is operational again since the end of 2008 after an upgrade of the lead spallation target and the associated cooling and ventilation system. The experimental area has been modified in order to comply with radioprotection and safety regulations, which is called work sector of type A at CERN. This crucial modification opens the way for measurements on radioactive targets exploiting fully the strength of the facility.

ACKNOWLEDGMENTS

For the realization of the second phase of the n_TOF facility we would like to acknowledge the commitment and continuous technical support from CERN, and in particular from Y. Body, R. Mollay, P. Carbonez, J. Lendaro, M. Lazzaroni, T. Otto, D. Grenier, S. Girod, S. Sgobba, L. Marques-Ferreira and D. Duarte-Ramos.

REFERENCES

1. T. Von Egidy and D. Bucurescu, *Phys.Rev. C* **72**, 044311 (2005)
2. G. A. Mitchell and H. A. Weidenmüller, *Rev. Mod. Phys.* **81** (2009) 539
3. F. Käppeler, *Progr. Particle Nucl. Phys.* **43** (1999) 419
4. G. Wallerstein et al., *Rev. Mod. Phys.* **69** (1997) 995
5. G. Aliberti et al., *Nucl. Sci. Eng.* **146** (2004) 13
6. A. Nuttin et al., *Progr. Nucl. Energy* **46** (2005) 77
7. C. Rubbia et al., *A high Resolution Spallation driven Facility at the CERN-PS to measure Neutron Cross Sections in the Interval from 1 eV to 250 MeV*, report CERN/LHC/98-02 (EET) + Add.1
8. C. Borcea et al., *Nucl. Instr. and Meth. Phys. Res. Sect. A* **513** (2003) 524
9. U. Abbondanno et al., *CERN n TOF Facility: Performance Report*, Tech. Rep. CERN-SL-2002-053 ECT (2003)
10. R. Plag et al., *Nucl. Instr. and Meth. Phys. Res. Sect. A* **496** (2003) 425
11. C. Guerrero et al., *Nucl. Instr. and Meth. Phys. Res. Sect. A* **608** (2009) 424
12. M. Calviani et al., *Phys. Rev. C* **80** (2010) 044604
13. C. Paradela et al., *Phys. Rev. C* **82** (2010) 034601
14. S. Andriamonje et al., *J. Instrum.* **5** (2010) P02001
15. S. Marrone et al., *Nucl. Instrum. Methods Phys. Res. Sect. A* **517** (2004) 389
16. <http://medipix.web.cern.ch/MEDIPIX/>
17. S. Andriamonje, et al., in Proc. Int. Conf. Nucl. Data for Sci. and Tech. ND2010 (2010) #1408
18. U. Abbondanno et al., *Nucl. Instrum. Methods Phys. Res. Sect. A* **538** (2005) 692
19. <http://www.cern.ch/ntof>