



Meer Mizanur Rahman

INVESTIGATIONS OF 5G LOCALIZATION WITH POSITIONING REFERENCE SIGNALS

Information Technology
Master's Thesis
March 2020

ABSTRACT

Tampere University
Master of Science Thesis, 50 pages
March 2020
Master's Degree Program in Information Technology
Major: Communication System and Networking
Examiners: Associate Professor, Elena-Simona Lohan
University Lecturer Dr. Jukka Talvitie

Keywords: Positioning Reference Signals, PRS, 5G, TDOA

TDOA is an user-assisted or network-assisted technique, in which the user equipment calculates the time of arrival of precise positioning reference signals conveyed by mobile base stations and provides information about the measured time of arrival estimates in the direction of the position server. Using multilateration grounded on the TDOA measurements of the PRS received from at least three base stations and known location of these base stations, the location server determines position of the user equipment.

Different types of factors are responsible for the positioning accuracy in TDOA method, such as, the sample rate, the bandwidth, network deployment, the properties of PRS, signal propagation condition etc. About 50 meters positioning is good for the 4G/LTE users, whereas 5G requires an accuracy less than a meter for outdoor and indoor users. Noteworthy improvements in positioning accuracy can be achievable with the help of redesigning the PRS in 5G technology.

The accuracy for the localization has been studied for different sampling rate along with different algorithms. High accuracy TDOA with 5G positioning reference signal (PRS) for sample rate and bandwidth hasn't been taken into consideration yet. The key goal of the thesis is to compare and assess the impact of different sampling rates and different bandwidths of PRS on the 5G positioning accuracy.

By performing analysis with variable bandwidths of PRS in resource blocks and comparing all the analysis with different bandwidth of PRS in resource blocks, it is undeniable that there is a meaningful decrease in the RMSE and significant growth in the SNR. The higher bandwidth of PRS in resource blocks brings higher SNR while the RMSE of positioning errors also decreases with a higher bandwidth. Also, the number of PRS in resource blocks provides lower SNR with higher RMSE values. The analysis with different bandwidths of PRS in resource blocks reveals keeping the RMSE value lower than a meter each time with different statistics is a positivity of the research.

The positioning accuracy also analysed with different sample size. With an increased sample size, a decrease in the root mean square error and crucial increase in the SNR was observed.

From this thesis investigation, it is inevitable to accomplish that two different analysis (sample size and bandwidth) done in a different way with the targeted output. A bandwidth of 38.4 MHz and sample size $N = 700$ required to achieve below 1m accuracy with SNR of 47.04 dB.

PREFACE

The investigation and master's thesis have been supported under the direction of Associate Professor Elena-Simona Lohan and Dr. Jukka Talvitie in the Electrical Engineering Unit of Tampere University, Tampere, Finland.

I would like to direct my gratefulness to my thesis overseers, Elena Simona Lohan and Dr. Jukka Talvitie, for their inspiration and scrupulous guidance. I would expressly thank Elena Simona Lohan for her caring support throughout the whole period of the thesis work. I've erudite a lot more than the thesis itself from Elena Simona Lohan and Dr. Jukka Talvitie.

Lastly, I would like to show gratitude to my parents, especially mother, Rahela Akhter, siblings and friends, for their support completing my master's study effortlessly.

Tampere, March 2020

Meer Mizanur Rahman

CONTENTS

1. INTRODUCTION	1
1.1 4G and 5G	1
1.2 Motivation and related works.....	3
1.3 Thesis goals.....	4
1.4 Author's contributions.....	4
2. OVERVIEW OF CELLULAR-BASED POSITIONING IN 4G AND 5G	6
2.1 Basic principles of cellular positioning	6
2.1.1 TOA	7
2.1.2 Time Difference of Arrival (TDOA)	7
2.1.3 AOA (Angle of Arrival).....	9
2.1.4 RSS	10
2.1.5 PRS signals in 4G.....	11
2.1.6 PRS signals in 5G.....	13
2.2 Main Challenges in Cellular positioning.....	14
2.2.1 Multipath	14
2.2.2 Interferences.....	16
2.2.3 MIMO and smart antenna systems (SAS)	16
2.3 Terms and factors related to channel characteristics.....	18
2.3.1 LoS/NLoS	18
2.3.2 Shadowing and fading	18
2.3.3 Scattering	19
3. TDOA ADVANTAGES, DISADVANTAGES AND FACTORS FOR ACHIEVING HIGH-ACCURACY TDOA.....	20
3.1 TDOA.....	20
3.2 Advantages, Disadvantages.....	20
3.3 Factors for Achieving High-Accuracy TDOA.....	22
3.3.1 Timing accuracy.....	22
3.3.2 Bandwidth and sample rate.....	22
3.3.3 Correlation and Signal Periodicity	23
3.3.4 Network geometry.....	23
3.3.5 Obstacles.....	24
4. 5G POSITIONING SIMULATOR	25
4.1.1 Broadcast Configuration.....	27
4.1.2 Plot Position of Mobile Base station and User Equipment.....	27
4.1.3 PRS Configuration	29
4.1.4 Broadcast Generating	30
4.1.5 Computing delays from base station to UE's.....	31
4.1.6 Quantity of Established Waveforms and Plot Conventional Waveforms	32
4.1.7 Accomplishing Cell Search and Launching Cell Identities	32
4.1.8 Computed Time Difference of Arrival	33
4.1.9 Computing TDOA and design frequent TDOA hyperbolas	36

5. SIMULATION BASED RESULTS.....	38
5.1 Analysis with Different Bandwidth of PRS in resource blocks.....	40
5.2 Performing analysis with different Sample Size.....	44
5.3 Investigation of Received waveforms at UE Locations.....	48
6. CONCLUSION AND FUTURE WORKS.....	49
7. REFERENCES.....	51

LIST OF FIGURES

<i>Figure 1: Multilateration based on classical TDOA [63].....</i>	8
<i>Figure 2: An incoming signal hits an antenna array. There are M antennas spaced d apart. This results in an additional path of $d \sin(\theta)$ at each subsequent antenna. source: (52).....</i>	9
<i>Figure 3: Example of single input, single output and multiple input, multiple output source: [61].....</i>	17
<i>Figure 4: Multiple hyperbolas for the optimal position.....</i>	25
<i>Figure 5: eNodeB configurations from matlab with parameters [68].....</i>	27
<i>Figure 6: Plot location of eNodeB's and UE.....</i>	28
<i>Figure 7: PRS sent by eNodeB's.....</i>	29
<i>Figure 8: Base stations with their positions.....</i>	30
<i>Figure 9: Broadcast generation from MATLAB [68].....</i>	31
<i>Figure 10: Computing delays from eNodeB's to UE's [68].....</i>	31
<i>Figure 11: Accomplishing cell search and launching cell identities [68].....</i>	33
<i>Figure 12: PRS correlations for detected cells at UE location for eNodeB 1 and 2.....</i>	34
<i>Figure 13: PRS correlations for detected cells at UE location for eNodeB 1 and 2.....</i>	35
<i>Figure 14: Different view of the positions with different Tx power.....</i>	36
<i>Figure 15: SNR vs RMSE with a Bandwidth of 38.4 MHz and 36.2 MHz.....</i>	40
<i>Figure 16: SNR vs RMSE with a Bandwidth of 38.4 MHz and 35.1 MHz.....</i>	41
<i>Figure 17: SNR vs RMSE with a Bandwidth of 36.2 MHz and 35.1 MHz.....</i>	42
<i>Figure 18: SNR vs RMSE with a Bandwidth of 38.4 MHz, 36.2 MHz and 35.1 MHz.....</i>	43
<i>Figure 19: SNR VS RMSE with Sample Size, $N=600$ and $N=700$.....</i>	44
<i>Figure 20 : SNR VS RMSE with sample size, $N=500$ and 700.....</i>	45
<i>Figure 21 : SNR VS RMSE with sample size, $N = 500, 600$ and 700.....</i>	46
<i>Figure 22: Received waveforms at UE locations.....</i>	48

LIST OF TABLES

<i>Table 1: Positioning reference signal main parameters in 4G.....</i>	12
<i>Table 2: Supported flexible transmission numerology in 5G-NR, source [55].....</i>	13
<i>Table 3: Multipath mechanisms source: [7].....</i>	15
<i>Table 4: SNR VS RMSE when Sample Size, $N = 600$ and $N=500$.....</i>	47

LIST OF SYMBOLS AND ABBREVIATIONS

5G	5 th generation cellular network
5G NR	5G New Radio
5G-NI	5G network interface
AAS	Adaptive Antenna System
AP	access points
AOA	Angle of Arrival
AWGN	Additive white Gaussian noise
BLE	Bluetooth Low Energy
CDF	Cumulative Density Function
CDMA	Code Division Multiple Access
CP	Cyclic-prefix
CRS	Cell-specific reference signal
CFK	Cluster Filtered K-Nearest Neighbour
CRS	Cell-specific reference signal
CRLB	Cramer-Rao lower bound
CW	Unmodulated continuous wave
db	Decibel
dBm	Decibel-milliwatts
eNB	Evolved Node B or <i>eNodeB</i>
FCC	Federal Communications Commission
FM	Frequency Modulation
GNSS	Global Navigation Satellite Systems
GSM	Global System for Mobile Communication
GPS	Global Positioning System
GEV	Generalized Extreme Value
GNS	Global Navigation System

HLF	Hyperbolic Location Fingerprinting
IoT	Internet of Thing
IR	Infrared Positioning
KLD	Kullback-Leibler Divergence
KNN	K-Nearest Neighbour
LEO	Low Earth orbit
LOS	Line-Of-Sight
NLOS	non-line-of-sight
LTE	Long-term evolution
MAC	Media Access Control
MIMO	multiple input multiple output
MISO	multiple input, single output
MU	Mobile User
NB	Narrow Band
NLOS	Non-Line-Of-Sight
NN	Nearest Neighbor
NPRSRS	Number of PRS in resource blocks
PDF	Probability density function
PL	Path Loss
PRS	Positioning reference signals
PSK	Phase-shift keying
PSD	Power Spectral Density
QoS	Quality of service
RFID	Radio Frequency Identification
RMSE	Root Mean Square Error
RSTD	Relative Standard timing difference between two cells or Reference Signal Time Difference
RSS	Received Signal Strength

RP	Reference Point
RSSI	Received Signal Strength Indicator
SAS	Smart antenna systems
SM	Spatial multiplexing
SD	Spatial Diversity
SIMO	single input, multiple output
SoO	Signals of opportunity
SS	Signal Strength
TDOA	Time Difference of Arrival
TOA	Time of Arrival
TSARS	Time and Space Attributes of Received Signal-Based Positioning-Technology
UHF	Ultra-High Frequency
UP	Ultrasound Positioning
UNB	Ultra-Narrow Band
UWB	Ultra-Wide Band
WF	Wireless Fidelity
WLAN	Wireless Local Area Network
WKNN	Weighted K-Nearest Neighbour
<i>a</i>	acceleration
F	force
<i>m</i>	mass

1. INTRODUCTION

Fifth generation radio networks will deliver marvelous improvements compared to the remaining mobile networks in terms of high capacity, data rates, and number of associated devices comprising vast number of sensors and *IoT* device. *3GPPTM* is a partnership project conveying together national standards development organizations from around the sphere primarily to advance technical stipulations for the 3rd generation of telecommunications, *UMTS*. 5G main characteristics are: Orthogonal Frequency Division Multiple Access (*OFDMA*), a unique positioning signal named Positioning Reference Signal (*PRS*) and *MIMO* antennas which refers to Multiple Input Multiple Output as information communication [1].

Discovering the location of user equipment in a noisy atmosphere deprived of outlying assistance is the key purpose of cellular positioning method. It is assumed in the thesis that the base stations (*eNodeB*) are in static locations and the user equipment can be fixed or moving [2].

An enormous range of positioning methods has been developed by means of the cellular network's signals, and among of them: Assisted-*GNSS*, *AOA*, enhanced Cell-ID (*e-CID*), *TOA* and time difference of arrival stands prevalent [49].

Mobile communication technology is sprinkling around the planet more rapidly than any other technology to date. From previous periods, communication advanced from being a classy skill for a limited designated society to today's pervasive structures enjoyed by a huge number of today's modern inhabitants. The universe has perceived many generations of cellular based communication arrangements; related by a precise number of nomenclatures and a precise customary of maintained use cases.

1.1 4G and 5G

4G refers to the fourth-generation cellular network technology which is identical with long term evolution technology, which is a progression of the prevailing third generation wireless standard. 5G is now the utmost modern *3GPP* radio access technology which delivers high data rates for end users, low access latency, and good spectral efficiency.

MIMO (concept is described in section 2.2.3 in this thesis) and OFDM are the dual crucial methods that empowered long-term evolution to achieve higher data output than 3G networks. The method for encoding digital data over various carrier frequencies is known as orthogonal frequency-division multiplexing, shortly OFDM [64].

It's an arrangement which allows multiple users sharing a mutual channel enabling high data rates. Using multiple antennas at the receiver and transmitter, *MIMO* method analyses data throughput and spectral efficiency. There are different types of *MIMO*, such as: multi-user *MIMO*, cooperative *MIMO*, macro diversity *MIMO*, *MIMO* Routing and massive *MIMO* [57]. Massive *MIMO* is the technology where the number of antennas at base stations is higher than the number of antennas at terminals.

Along with these, *MIMO* practices intricate digital signal processing setting up and about various data streams over similar channel. Time division duplex and frequency division duplex are being applied by long term evolution standard [3].

For the next bout of wireless communication, fifth generation, 5G will be the first choice of new generation. With the help of addressing latency, data ratings and energy efficiency, 4G will be replaced by 5G. The reduced latency up to levels below 01 *ms*, enlarged data rates of at least 01 *gigabit per second* for tens of thousands of users concurrently along with enlarged energy efficiency are expected to be provided by 5G cellular communication [58].

Through the announcement of 5G, the key target of 5G is to data collection, mobile technology, and wireless communication more flawlessly over speed and competence. Fourth-generation wireless networks typically focusing on the accessibility of fresh bandwidth, whereas the fifth generation is targeting on delivering universal connectivity [4].

5G has a frequency band of 3 *GHz* to 86 *GHz*, the exact bands could be chosen depending on the communication link application and data bandwidth of 1*Gbps* or higher whereas the fourth generation uses a frequency band of 2 *GHz* to 4 *GHz* and data bandwidth of 2*Mbps* to 1*Gbps* [59]. As a core network, 4G is using IP-based (Internet protocol) network, meaning that it uses a standard communications protocol to send and receive data in packets while the fifth generation is using 5G network interfacing shortly known as 5G-NI.

Cloud RAN and virtual RAN's are the novel designs of fifth generation networks development [5]. These RAN's are developing with the simplification of a much-unified network launch and making the finest usage of server farms over confined data centres at the network edges. There are a number of benefits of cloud-RAN architecture in mobile net-

work expansion, such as: energy efficiency and power cost reduction, capacity and spectral efficiency improvement, adaptability to non-uniform traffic, offloading smart internet traffic, and extensibility of network [46]. Additionally, fifth generation networks will be able serving the social network and industrial internet at the same time.

1.2 Motivation and related works

Position information has become a key feature in recent centuries to drive location and context aware services in mobile communications. Providing position information with sufficient accuracy, high availability and coverage is still a challenging task. Also, the positioning was established proceeding familiarity of the topographical arranges of user equipment serving base station component, which can be picked up performing following range overhaul or area update.

The accuracy of the position is in that circumstance is moderately robustious and be subject to the cell measure, which would not finish the exactness provisions [6].

A renowned positioning technique known as time difference of arrival, *TDOA* constructed depending on hyperbolic trilateration and by means of determining the alteration of arrival times and devoted downlink signals from various base station components to the user equipment [7]. With the help of *3GPP* Release no: 9 and *RSTD* (Reference Signal Time Difference) measurement, the superior devoted positioning reference signals remain announced [8].

Time difference of arrival based on a group of base stations with known locations has been widely used to detect objects. For a location system based on *TDOA*, the range variance among the target and different sensor nodes can be calculated when the measured data are obtained.

Analyzing the publications [9], [32-36] regarding positioning accuracy in the *TDOA* range, the assessment has exposed that this type of accuracy problem has been previously achieved in different ways. For example: in [9], $0.97m$ RMSE accuracy was obtained with a higher-level SNR value of $59.52dB$. Also, attainable localization exactness of positioning reference signal has been investigated only for different estimation algorithm.

The accuracy for the localization has been computed with the help of *Gauss – Newton* method and planned iterative algorithms for the Levenberg-Marquardt (*LM*), without taking consideration sample rate and bandwidth factors for achieving high accuracy *TDOA*

with 5G positioning reference signals (*PRS*) [9]. The key goal of the thesis remains to comparison and assessment of the different sample rate and analysis with different bandwidth of *PRS* in resource blocks for finding the targeted *RMSE* with lower *SNR*.

1.3 Thesis goals

The objective of this thesis is to estimate the accuracy of user equipment positioning with *TDOA* technique in 5G using positioning reference signals by solving hyperbolic trilateration difficulty with different algorithms and compare it with different sample rate and analysis with different bandwidth of *PRS* in resource blocks for finding the targeted *RMSE* with lower *SNR*.

We have developed *MATLAB* code including different algorithms, and channel effects such as AWGN etc. into subsequent simulation model. The simulation comprises characteristic cellular network scenario with spatially distributed base station components which allows equating the bandwidth capacities computing *SNR* and *RMSE*.

1.4 Author's contributions

5G positioning supports efficient and continuous localization counting protocols, architecture, *PRS*, and substantiation assessment. We have discussed about the overview of cellular-based positioning in 4G and 5G including main challenges in second fragment. The positioning model of *TDOA* technique counting advantages, disadvantages and factors is explained in the third part (Chapter 03). 5G positioning simulator along with *PRS* configuration, estimation etc. are presented in the fourth part (Chapter 04). Simulation based results through analysis with different bandwidth of *PRS* in resource blocks and different sample rate is described in the fifth part (Chapter 05). Later, a conclusion has been drawn in the next part.

This thesis also assesses the accuracy and feasibility of *TDOA* method under erratic system circumstances that might met in real circumstances which comprises varying environments of additive white Gaussian noise (*AWGN*), transmission control, multiple access interference, etc.

The consequence of user equipment and different planning of base positions on *TDOA* precision is also considered. It is revealed that this development can stretch greatly amended performance even beneath worst-case conditions.

2. OVERVIEW OF CELLULAR-BASED POSITIONING IN 4G AND 5G

2.1 Basic principles of cellular positioning

Localization is a method by which an element regulates its position with respect to a certain reference system. It is about knowing the location of any network node at any time. Thus, mobile or some other devices can be recognized as nodes, and their location either be static or can change.

The procedure of discovering location of mobile or some other devices is known as localization. Collecting information for the longitude, altitude and latitude of sensor node is the process of localization. Localization is a foreseeable contest while dealing with cellular bulges and these nodes can be fortified through global positioning system which is an expensive solution in relations to the volume, currency and control feasting.

Initially, cellular systems were not intended for positioning, the execution of different location approaches were required with new equipment making the essential calculations for location purpose and new signaling to transfer the measurement results to the location determination unit. Reckless and consistent localization of mobiles in cellular network is attaining higher importance in present and upcoming network.

Locating user equipment has always been a serious problem. It turns out to be complicated nowadays, as the amount of location accuracy software and applications are incessantly rising. Global positioning system is consistent and precise for outdoor circumstances, but sometimes GPS doesn't deliver satisfactory performance in urban areas along with indoor locations [10]. Technologies such as *AOA*, *TDOA* and *RSS* etc. have been industrialized with the intention of executing the specificities of global atmospheres.

2.1.1 TOA

Time of arrival stands modest and most communal oscillating system, most distinguished rummage-sale in the positioning system [11]. This technique is constructed on gaining precise time that the target sent a signal, meticulous time the signal reaches at a location point, and the signal travelling speed which known as speed of light.

Time of arrival approach uses a single packet sent from the base station to mobile station containing the time it was transmitted, relying on base station-mobile station synchronization to eliminate clock-related drift.

Since the receiving mobile station knows arrival time of packet and that it is synchronized with the base station, the distance travelled can be calculated using the following formula [60]:

$$d_{TOA} = c * t_{TOA} , [c, \text{speed of light}] \quad (1)$$

Equation (1) is used to calculate distance based on the time it took a signal to go from the transmitter to the receiver when d_{TOA} is the distance between the transmitters and receiver, c is the speed of light (approximately $(3 * 10^8 \text{ms}^{-1})$, and t_{TOA} is the time difference.

2.1.2 Time Difference of Arrival (TDOA)

Time difference of arrival correspondingly recognized as multilateration, an unshakable method for the geolocation of radio frequency emitters. By means of minimum three receivers, time difference of arrival locates a signal source from the different arrival times at the receivers. It is identically precise and active for most signal types, believing by the existing users of TDOA geolocation.

The accuracy of TDOA is defined by a number of factors. The general geo area precision can be no superior to the most noticeably terrible of these breaking points. Procedures will apply to any beneficiary innovation, despite the fact that outlining with designs, and in some cases referencing the manners that relieves the impact of certain wellsprings of error.

At the point when we show likelihood warmth maps for the area of a transmitter, the scale goes from violet to red with expanding likelihood.

TDOA also occurs based on the calculation of response time variances among positioning reference signals inward from numerous mobile base stations to the user equipment.

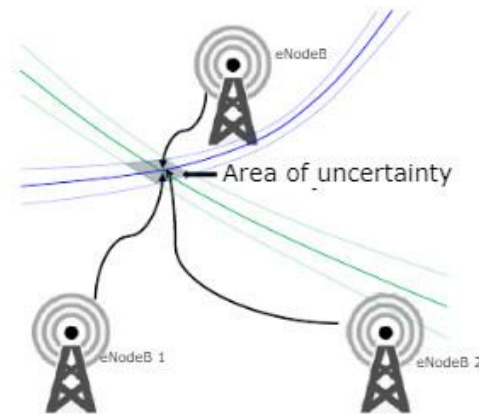

Figure 1: Multilateration based on classical TDOA [63]

This difference can be calculated using the following equation

$$\Delta d = c * (\Delta t),$$

where c is the speed of light and Δt is the difference in arrival times at each reference point. The following equation can be written for the *TDOA*

$$\Delta d = \sqrt{(x_2 - x)^2 + (y_2 - y)^2} - \sqrt{(x_1 - x)^2 + (y_1 - y)^2}$$

where (x_1, y_1) and (x_2, y_2) are the position of the base stations. With nonlinear regression, this calculation can be transformed to the form of a hyperbola. When sufficient hyperbolas have been calculated, the location of the target can be achieved by finding the intersection [56].

2.1.3 AOA (Angle of Arrival)

The angle among an orientation direction and the way of spread of an event ray refers to angle of arrival. The direction for the reference is named orientation and is static. The AOA is calculated in degrees and from the north direction with clockwise.

By using the RSS at different antennas, or the phase of the incoming signal measured at these antennas, AoA estimation are calculated.

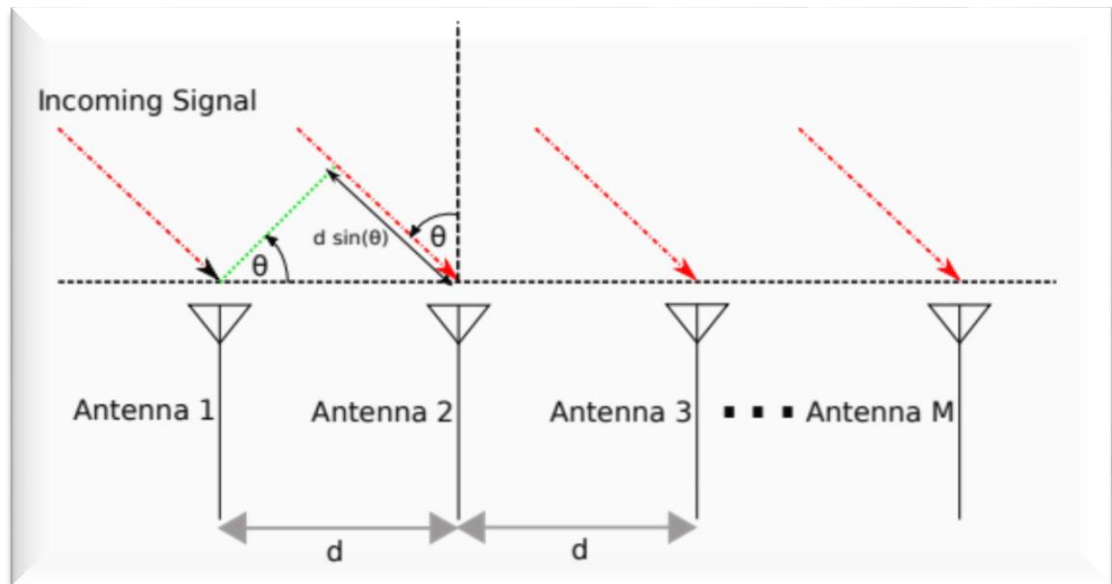

Figure 2: An incoming signal hits an antenna array. There are M antennas spaced d apart. This results in an additional path of $d \sin(\theta)$ at each subsequent antenna. source: (52)

In AOA, the signal has to travel further to reach each subsequent antenna where there is a phase shift. This phase shift between two subsequent antennas can be calculated as follows:

$$\Delta\phi = -2\pi \frac{d \sin(\theta)}{\lambda} \quad (2)$$

Whereas, f is the frequency of the signal and λ is the wavelength of the signal. One can relatively easily calculate θ from equation (2).

$$\theta = \arcsin\left(\frac{\Delta\phi\lambda}{-2\pi d}\right)$$

While this modest approach works fine specified only one signal applying it to internal localization will cause expressively worse results. The reason is that in a normal indoor scenario the incoming signal will be the combination of different reflected, time delayed and attenuated signals arriving at the antenna. Solving this multipath problem, Multiple Signal Classification algorithm (*MUSIC*) [52] can be used. *MUSIC* uses an eigenspace method to estimate, the AOA of several signals arriving at the antenna array.

When the angle of arrival calculates $\theta = 0^0$ (0 degree), and pointing to the north direction, the angle of arrival then is known as absolute [14].

2.1.4 RSS

The dimension of the power of a received radio signal is known as received signal strength, shortly *RSS*. Received signal strength is unique to the reader productions, shimmering the power of a conventional backscattered signal, P_{Rx} , which is mostly used in RFID systems. *dbm* is the unit for the measurement of *RSS* and can be defined as:

$$RSS = 10\log\left(\frac{P_{Rx}}{1mW}\right)$$

The received signal strength (*RSS*) is the strong point of a received signal restrained at the receiver's antenna. Received signal strength is determined by the broadcast power, radio environment and the distance between the receiver and transmitter. The *RSS* is a parameter which is difficult to simulate arbitrarily and it's highly linked to the transmitter's parameter.

In the *RSS* -based positioning method, there will be several access points (*eNodeB*) at different fix locations serving as *RSS* sensors that measure *RSS* readings of wireless traffic transmitted from the wireless nodes in the area of interest.

RSS method is simple to obtain and use but requires a dense network of receivers. There are two distinct scenarios in which *RSS* measurements can be obtained: cooperative and non-cooperative. In cooperative systems, such as cell phone handset geolocation by base stations, the reported *RSS* is often just the signal power, as the digital signal can be demodulated and segregated from additive noise.

RSS in *dB* at each sensor is Gaussian with variance σ^2 . Typically, σ ranges from 4 *dB* to 12 *dB* [53], corresponding to uncluttered environments to environments rich in shadowing and multipath. The value of σ^2 can be approximated from controlled measurements in a given environment. Due to shadowing and multipath, the path loss exponent η may deviate from its free space value of 2. It may be as large as 5 in dense urban environments, though some sources state that typical values of η are in the range of 2 to 4. The reference transmit power is P_0 , in *dB*; this is the power that would be received at a reference distance of $d_0 = 1$ m. P_0 and η can be included as nuisance parameters [54].

Considering idealized model, receiver nodes S at known positions (x_s, y_s) , for $s = 1, 2, \dots, S$. The transmitter is at an unknown position (x_0, y_0) , the transmitter to receiver distance is then

$$d_s = \sqrt{(x_s - x_0)^2 + (y_s - y_0)^2}$$

2.1.5 PRS signals in 4G

To enhance user equipment geolocation accuracy, positioning reference signal is used. Following the characteristics by the parameters of PRS, positioning reference signal is transmitted occasionally in certain outlines and involves certain resource components inside a rectangular zone within the outline.

With different time-frequency distributions and according to the physical layer, long-term evolution grade [17] stipulates bunch of downlink signals grounded on an orthogonal frequency-division multiplexing modulation. Downlink synchronization and positioning reference signals are totally recognized (e.g.: experimental signals in global navigation satellite system), and such way, these are appropriate for ranging initiatives. Particularly, the main and inferior synchronization signal, for example *PSS* and *SSS*, besides the cell-

specific reference signal (CRS), can be cast-off for signals of opportunity (*SoO*) applications because they do not require any assistance data.

Nevertheless, long-term evolution maintains the characteristic of frequency reuse factor in a cellular network, and that is equal to one. So, the established serving cell signal delays with the established neighbor cell signals creating inter-cell interference and resulting in the near-far effect. With the intention of obtaining exact ranging measurements of the nearby cells, the standard of long-term evolution releasing 9 stipulates a positioning reference signal known as *PRS*, is especially devoted for the purpose of positioning. Also, it alleviates the near-far effect, as a result of higher frequency reuse factor, by shifting one subcarrier position the frequency pilot allocation transmitted by each base station.

The key constraints for positioning reference signal configurations are exposed in the below table. The *PRS* signal is dispersed in time and frequency in the so-called positioning occasion, which assigns successive positioning sub frames with a convinced periodicity. With the purpose of reducing the inter-cell interference, when the network mutes the *PRS* transmissions of selective base stations (for example: *PRS* muting), the complexity of this signal is gets sophisticated.

<i>PRS</i> bandwidth	1.4, 3, 5, 10, 15 and 20 MHz
Consecutive subframes	1, 2, 4, or 6
<i>PRS</i> periodicity	160, 320, 640 or 1280 ms
<i>PRS</i> pattern	6 – reuse in frequency
<i>PRS</i> sequence	Length – 31 Gold sequence
Information on muting Positioning Reference signal	1, 2, 4, 8, 16 bits

Table 1: Positioning reference signal main parameters in 4G

2.1.6 PRS signals in 5G

5G systems will continue to use the Positioning Reference Signals (*PRS*) employed now in 4G systems, in order to enable positioning with non-synchronized Base Stations (BS) with an increased performance compared to 4G positioning. *PRS* are used to measure the delays of the downlink transmissions by correlating the received signal from the base station with a local replica in the receiver.

5G-NR transmissions are more flexible than their predecessor technologies. 5G-NR signals can be transmitted using different numerology [55].

Sub-carrier spacing (Δf)(kHz)	Symbol duration (T_s), (μs)	Cyclic Prefix (T_{CP}), (μs)	Number of slots per frame	Slot duration T_{slot} , (ms)	Frequencies below 6 GHz	Frequencies above 24 GHz
15	66.67	4.69	10	1	Y	N
30	33.33	2.34	20	0.5	Y	N
60	16.67	1.17	40	0.25	Y	Y
120	8.33	0.57	80	0.125	N	Y
240	4.17	0.29	160	0.063	N	Y

Table 2: Supported flexible transmission numerology in 5G-NR, source [55]

2.2 Main Challenges in Cellular positioning

2.2.1 Multipath

Multipath is an antisocial method that afflicts many communication channels, ranging from cable to satellite systems. The mechanisms tangled in positioning very widely, but they provide growth to very similar effects on communication systems using multipath channels. The object of this communication colloquium is to consider counter measures against these effects. While its focus is on radio systems (since it is being organized by the professional group on radio communications), other types of multipath techniques might be applicable to other types of systems [18]. Where there is more than a path for the signal among transmitter and receiver, multipath happens.

Multipath fading consequence consumed to be dealt with the demand of maintaining certain quality of service (QoS). Though transmitted indication is imitated onto numerous substances on its path to the receiver, there's a chance of signal fading and distortion and the phenomenon is known as multipath fading [25].

An antenna operates under multipath conditions when in it impinge radio waves arriving from different directions. This is particularly predominant in radio structures as it is usually more problematic to restrain the energy of the signal to unique specific track, but this can transpire in many kinds of arrangement. Table below a list many of the systems in which multipath occurs and summarizes its mechanism in each case.

	<u>System</u>	<u>Multipath mechanism</u>
1.	Microwave point to point relations	Refraction and Reflection of Atmospheric
2.	Satellite Mobile system	Ground and building reflection
3.	Mobile and Personal radio	Scattering from buildings, reflection and terrain, etc.
4.	HF radio	Reflection from multiple ionospheric layers.

5.	Indoor Radio or Radio LAN	Echo from building structure and walls
6.	Telephone/cable network	Reflections from terminations

Table 3: Multipath mechanisms source: [7]

A large number of factors are responsible for the severity of multipath effects. The first is the presence and relative power of any dominant path. In radio systems this is usually, but not invariably, the line-of-sight path. In mobile/personal radio systems, some indoor radio systems, and some satellite-mobile systems (especially at low elevation angles) this is frequently weak or absent due to shadowing by obstructions. Its presence and strength determine the fading characteristics of the signal (of which more later). The second factor of interest is the range of delays experienced by multipath components, due to the different distances travelled.

This can often be determined from the geometry of the situation, but in many systems the maximum delay is effectively infinite [19]. For example, in indoor radio systems infinitely many reflections may occur from walls, and in mobile radio the scatters may be very distant relative to the transmitter. In these cases, however, the components with very long delays will be negligible. This delay range will affect the dispersion suffered by the channel [20]. Due to the motion of transmitter, scatters or receiver, some of the systems mentioned have stationary channels, but most are to some degree time-variant. In many cases, however, the channel can be mated as stationary over the period of a given transmission, although its variability will have to be considered in computational operating margins for the system.

Others, in particular mobile radio and LEO satellite mobile systems are subject to rapid variations. Alternative views of such channels are obtained by considering Doppler effects because of the motion. Comparative motion of transmitter scatters or receiver on any given path will cause a frequency shift to the received signal. Overall this may cause a Doppler spreading effect, where a single transmitted frequency is spread over a band of frequencies (the Doppler spectrum) due to different Doppler shifts in different multipath components [21]. Also, strong multipath can bias the delay estimator.

2.2.2 Interferences

In telecommunications, interference is something that alters a signal in a troublesome manner, while travels laterally in a channel between its receiver and source. The stretch is used to refer to the accumulation of undesirable signals to a suitable signal. Examples are electromagnetic interference, crosstalk or co-channel interference, inter symbol interference, adjacent-channel interference, inter-carrier interference (instigated by Doppler shift in OFDM modulation) [47].

Maximum high-rate data transmission production was using wired communications, whereas wireless communications focused on voice and smaller data transfers. In topical years, wireless multimedia applications, for example mobile phones having an integrated camera, emailing capability and position detection, etc. have a histrionic boost.

As an outcome, the attention arises towards wireless high-speed data transfers. For the reason of multipath and co-channel interference, traditional antennas are not capable of delivering the proper output [25]. Along with the necessities of high-speed data transfers, there is also a substance of quality control, which consist of high capacity and low error rate.

2.2.3 MIMO and smart antenna systems (SAS)

Smart antenna systems (SAS) and massive multiple input multiple output (MIMO) systems are known as the most recent antenna array technologies. These technologies are providing a strong increasing impact relative to 5G wireless communication systems due to benefits that they could introduce in terms of performance developments.

In conventional MIMO systems, like the long-term evolution (LTE), the base station transmits waveforms depending on terminals channel response estimation, and then these responses are quantized by some processing units and sent out back to the base station. Whereas massive MIMO systems works another way, especially in high-mobility environments [20], optimal downlink pilots get mutually orthogonal among the antennas. So, in spite of the difficult hardware and designing implementation, these systems are becoming increasingly prevalent in the modern applications due to the great benefits like increasing the wireless channel capacity up to 10 times and radiated energy-efficiency

up to hundred times. All these assistances with respect to the traditional long-term evolution schemes [26].

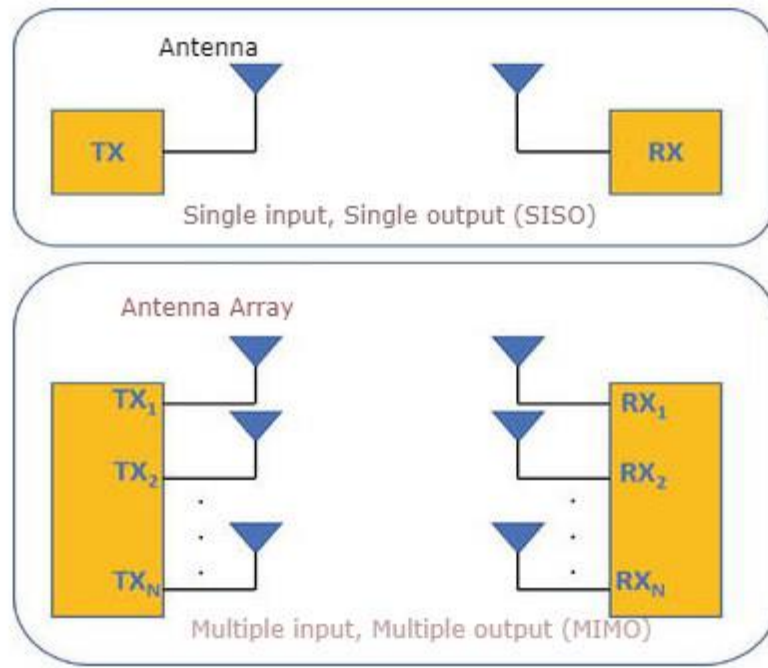

Figure 3: Example of single input, single output and multiple input, multiple output source: [61]

A smart antenna system generally combines an antenna array with a digital signal processing volume to transmit and receive in an adaptive, spatial manner. Smart antennas are categorized into SIMO, MISO, MIMO. Only one antenna is used at the source, and two or more antennas are used at the destination in SIMO technology. Whereas, several antennas are used at the transmitter, and one antenna is utilized at the destination in MISO technology. Multiple antennas are used at both source and destination in the MIMO technology [61].

2.3 Terms and factors related to channel characteristics

2.3.1 LoS/NLoS

A type of propagation which can receive and transmit information only where transmission and receiving stations are in the view of each other deprived of any sort of a hindrance among them is known as line of sight, shortly *LoS*.

The route of propagation of a radio frequency which is partially or completely masked by hindrances and assembling it difficult for the radio signal to pass through refers to non-line of sight (*NLoS*).

Not only for location-based applications and facilities in internal atmosphere, but also for overwhelming the adverse impact of *NLoS* broadcasts in any kind of wireless services, awareness of line of sight / non-line of sight conditions turn out to be a vital asset.

For illustration, the transmitter could tune the power or the data rate attaining a further dependable communication with the information of *LoS/NLoS*. Another case of the use is refining the accuracy in the site approximation in positioning systems with the help of *LoS/NLoS* identification. Attaining most dependable data determining the location of a device in different atmospheres, consciousness of *LoS/NLoS* could be a vital factor [27]. Such way, for accurate localization system, *LoS/NLoS* credentials could be a pre-requisite.

2.3.2 Shadowing and fading

Shadowing refers to the outcome that the received signal power differs owing to the substances obstructing the broadcast path among transmitter and receiver. These variations are practiced on the local-mean influences.

Owing to multipath propagation, denoted to as multipath persuaded fading, climate (mainly rain), or surveillance from hindrances distressing the wave propagation, occasionally stated as shadow fading [28].

2.3.3 Scattering

When the propagating wave encounters a rough surface, scattering occurs. As level of roughness increases, the amount of scattering increases and the energy from the specular reflected component is reduced.

Whenever gains in intensity due to scattering along a line of sight are insignificant related to the following gains and losses, scattering can be ignored [30]:

- The losses attributable to extinction
 - Improvements attributable to thermal emission
-
- Elastic scattering – when the frequency of the sprinkled light is the same as the occurrence light, mainly Rayleigh and Mie scattering elastic scattering occurs [66].
 - Inelastic scattering – if the produced radiation has a frequency dissimilar from that of the event radiation like Raman scattering, fluorescence inelastic scattering befalls [66].
 - Quasi-elastic scattering – when the frequency of the dispersed light moves (for instance, in moving matter due to Doppler effects, Quasi-elastic scattering transpires [65].

3. TDOA ADVANTAGES, DISADVANTAGES AND FACTORS FOR ACHIEVING HIGH-ACCURACY TDOA

3.1 TDOA

Time difference of arrival known as *TDOA*, which is founded on the knowledge of calculating the variance in distance to multiple base stations as contrasting to two way ranging that calculates the intervening space between user equipment to base stations. By means of the speed of light, time can be transformed to distance and time in this framework is associated to spread of radio waves.

Approximating the location from *TDOA* data is little difficult whether it's easier in two way ranging data and it might seem outlandish to use this set up in *TDOA*. Nevertheless, the foremost purpose is that it's not impossible gauging the time difference of arrival data in the user equipment through passively paying attention to the messages directed by the broadcasters. As the user equipment is only paying attention, there is no restriction in the structure for the quantity of identifiers that can be detriment simultaneously likened to global positioning system satellites and receivers [32].

3.2 Advantages, Disadvantages

A *TDOA* system determines the variance in the topic of interest's distance to pairs of stations at known fixed locations. For one station pair, the distance difference results in an infinite number of possible subject locations that satisfy the *TDOA*, but characteristically they necessitate a bandwidth concentrated cross relationship among receivers [33].

- *TDOA* increasingly useful due to the availability of inexpensive and compact computing power
- With advanced processing techniques, *TDOA* may be used to geolocate high bandwidth signals indoors and outdoors at short range ($< 100\text{ m}$ on a side) and in high multipath environments [62].
- Shadowing properties of tall structures like structures, buildings are possible to overcome for the *TDOA* receivers.

- *TDOA* performs well for new and emerging signals with complex modulations, wide bandwidths, and short durations.
- TDOA performance is a strong function of signal bandwidth. TDOA performance generally improves as signal bandwidth increases.
- With wide bandwidths, complex modulations and short durations, it performs well for novel and evolving signals
- Due to its simpler antenna than AOA, power, size, and simplified positioning necessities, it is well-matched to numerous receiver deployments.

TDOA Disadvantages

TDOA also has weaknesses with respect to other positioning method, especially in locating narrowband and unmodulated signals, usually more demanding data backhaul requirements, and it requires at least two receivers for line of position information and at least three receivers for location in 2D. Modern signal monitoring is experiencing a trend toward ever increasing signal bandwidths and decreasing power spectral densities.

- *TDOA* requires additional hardware compared to other positioning method such as AOA to make synchronization more precise
- TDOA requires high quality time synchronization relative to the inverse bandwidth of the signal of interest.
- TDOA algorithms may generate signals that might contain periodic elements under some conditions. Repeating data sequences or synchronization pulses are the examples of such signals.
- Sampled signals are typically transmitted to a geolocation server for computation. These areas demand on networking capacity and speed. Geolocation compute time can be significantly delayed for a slow link.
- A minimum of 3 sensors are needed for geolocation in 2D for TDOA, whereas AOA can be used for single site location
- TDOA accuracy is precise when the signal source is within a limit. Immediately outside this perimeter, the location precision and effectiveness decrease more rapidly for TDOA than for AOA [33].

3.3 Factors for Achieving High-Accuracy TDOA

3.3.1 Timing accuracy

Achieving high accuracy *TDOA*, localization of user equipment and *eNodeB* are indispensable. Accuracy for the *TDOA* is strappingly rely on the excellency of reception, but sometimes it will every so often be restricted to few *meters* under distinctive circumstances.

For the reason of jamming or solar flares if user equipment is not found where *TDOA* geolocation is needed, an alternative synchronization method is necessary to proceed.

3.3.2 Bandwidth and sample rate

Depending on the sample rate, time resolution and spatial resolution can be foreseeable from TDOA network. For instance, sampling a gesture of 10 *MHz* stretches a time resolution of

$time = 1/frequency = 1/10\text{ MHz} = 0.1\ \mu\text{s}$; Which corresponds to spatial resolution of

$$distance = speed\ of\ light \times time = 3 \times 10^8\ m/s \times 0.1\ \mu\text{s} = 30\ m <$$

Tactlessly, to make progress in TDOA accuracy, sample rate and bandwidth plays a vital role. It's possible getting a law of diminishing returns, as the differences are gradually related to noise rather than to differences in the signal by rising the sample rate much beyond the bandwidth of the signal or modulation rate. The ideal illustration rate for time difference of arrival will be comparable with the bandwidth of the signal, which is being geolocated, and the exactness will be specified roughly by

$$accuracy = speed\ of\ light / bandwidth = 3 \times 10^8\ m/s / bandwidth$$

that is reliable with an accurateness of 10 *m* at a bandwidth 10 *MHz*, deteriorating to 100 *m* at 100 *MHz*.

3.3.3 Correlation and Signal Periodicity

Correlation is a quantity of similarity between two signals. The broader correlation peak resembles to a greater imprecision in the time delay, and henceforth it effects to the accuracy of location [38].

When a signal is periodic, the function of cross-correlation will have more than a peak, corresponding to more than one conceivable standard for the time. There is more than one location is feasible (once the period is shorter), the location will then fall into uncertainty [39].

The distance among conceivable positions will be of the order in the periodicity of *TDOA*

$$3 \times 10^8 \times period$$

Thus, *TDOA* is unlikely to be fruitful once the period is *microseconds* or a smaller amount (positions are no more than *hundreds of meters* apart) and likely to be fruitful once the period is *milliseconds* or greater (possible locations are *hundreds of kilometers* at a distance). The worst circumstance is an unmodulated continuous wave which is also known as CW signal, for which time difference of arrival geolocation is improbably to be useful, except for the rate of recurrence lower than 1 *MHz*. Angle of arrival geolocation performs much better than *TDOA* for periodic signals [40].

3.3.4 Network geometry

Where there is a small alteration in time variance results from a minor alteration, and less precise if a greater alteration in position is needed. To generate the similar minor alteration in time variance, the geolocation will be the utmost precise at a location [41].

To an initial calculation, the greatest accurateness will be attained once the transmitter deceits within the UE of the three (otherwise further) *eNodeB*. Uncertainty announced by other issues will be exaggerated by the geometry outside of the UE [42]. The image below provides information regarding greater uncertainty in location. With the sequential estimation method, it is crucial to infer the estimated position and find the resolution of the matter.

3.3.5 Obstacles

It is essential for the receivers to be able to “take into consideration” the signal with location load: hindrance known as shadowing will avert successful geolocation for the time difference of arrival. From reflected and diffused signals multipath effects might convolute geolocation, while time difference of arrival is relatively strong in exchange for multipath comparing with angle of arrival methods of geolocation. The prime hindrance of entirely, the earth’s flexure can also make flashpoint time difference of arrival over long extent [43].

For network optimization, the existence of hindrances is a vital aspect. The easier it will be to see around obstacles such as mountains, buildings and the earth itself, once the receiver altitudes will be bigger. Optimal positioning can also progress geolocation performance for any given height overhead base level. For instance, placing receivers on the pinnacle of hills rather than backward of location.

Using simulation and modeling tools are habitually beneficial, such as which granted by CRFS, modeling these obstacle and effects of receiver positioning as well as the other issues distressing accuracy of time difference of arrival. These let geolocation circumstances to be established and placement of receiver to be improved beforehand a practical implementation of network [44].

4. 5G POSITIONING SIMULATOR

The following positioning simulator provides the way of using the time variance of arrival (*TDOA*) positioning tactic in combination through the *PRS* to analyze the location of a user kit in the interior of a system of base station using *MATLAB* LTE Toolbox™.

A sum of base station transmissions is formed and united along with diverse adjournments and received powers to model the reception of the entire base station waveforms through one user equipment. The user equipment achieves connection with the *PRS* launching postponement from each base station and afterward the postponement difference among all duos base station. These postponement changes are accustomed to figure out the hyperbolas of continuous postponement alteration, which are conspired qualified to known base station positions and having the traverse at the location of user equipment.

The target localization based on *TDOA* measurement is presented in the line of sight environment. Determining the position of the target, let's assume there are $N \geq 3$, eNodeB, which can also be called base sensors (*BS*), to determine the position of the target.

The coordinates of the sensor nodes are known, which are $S_i = (a_i, b_i)^T$,

$i \in \{1, 2, \dots, N\}$, where $[\]^T$ denotes the matrix transpose. Assuming that the target's coordinate is $P = (x, y)^T$.

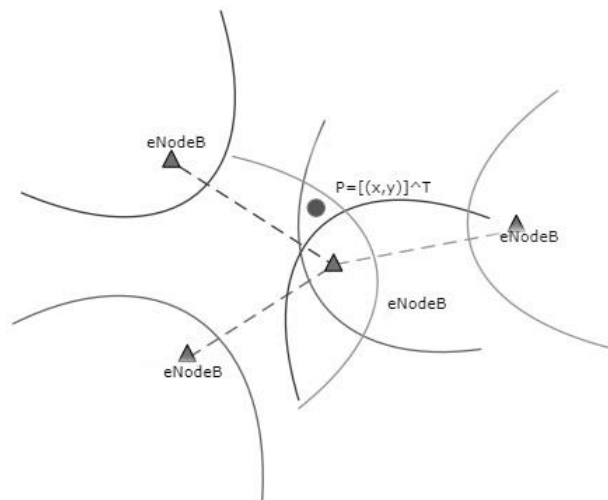

Figure 4: Multiple hyperbolas for the optimal position

There are base stations in the 2D plane to determine the position of the target which form group of hyperbolas. The hyperbola has intersections in the absence of noise and there is one ambiguous position in them.

Once the noise exists, the other group of hyperbolas have other intersections and all the intersections have errors. It is suggested to increase the number of the base stations to avoid ambiguous position. Figure 4 demonstrated *eNodeB*'s, where base stations form group of hyperbolas. When noise exists, it is necessary to follow certain principles to obtain the optimal results.

Taking the first base station *eNodeB*₁ as a reference sensor and assume that the signal propagates in a straight line between the target and each base station without considering the influence of NLOS propagation.

Let's assume, t_1 and t_2 as times the signal arrives at base station *eNodeB*₁ and *eNodeB*_{*i*} with the propagation speed of the signal is c .

The distance between the target and base station *eNodeB*₁ and *eNodeB*_{*i*}, is $\{r_{i,1}\}$.

This thesis assumes that range difference errors $\{n_i\}$ are independent Gaussian random variables with zero mean and known variance σ_i^2 , i. e., $N(0, \sigma_i^2)$. So,

$$\{r_{i,1}\} = c |t_1 - t_i|$$

$$\{r_{i,1}\} = d_{i,1} + n_{i,1}, i \in \{2, \dots, N\}.$$

taking $d_{i,1} = d_i - d_1$, we found $c |t_1 - t_i| = d_{i,1} + n_{i,1} \dots (01)$

So, distances among the target and the receiver pair *eNodeB*₁ and *eNodeB*_{*i*} can be written as:

$$d_1 = \sqrt{(x - a_1)^2 + (y - b_1)^2 + (z - c_1)^2}$$

$$d_i = \sqrt{(x - a_i)^2 + (y - b_i)^2 + (z - c_i)^2}, \quad i \in \{2, \dots, N\}.$$

The process of obtaining results based on *TDOA* measurements is the process of solving the $N - 1$ equation from equation (01) and obtaining the optimal solution.

4.1.1 Broadcast Configuration

Cell array of base station arrangements are the consequent from R5 reference measurement channel. The R.5 defines a bandwidth downlink shared channel known as *PDSCH* transmission by means of $64 - QAM$ modulation. Intended for individual base station, to make the cell identity exclusive, the formation is modernized and other parameters like *IPRS*, *NPRSRB*, and *PRS* period have been settled. With the help of *X, Y, Z* coordinates for each and every mobile base station, a random position is being generated, where the number of *eNodeB* was five.

```

NeNodeB = 5;    % Number of eNodeB

% Create eNodeB configurations
enb = cell(1,NeNodeB);
]for i=1:NeNodeB
    enb{i}=lteRMCDL('R.5');           % Get configuration based on RMC
    enb{i}.NCellID = mod(( i-1)*2,504); % Set arbitrary cell identity
    enb{i}.TotSubframes = 1;          % Number of subframes to generate
    enb{i}.NPRSRB = 15;               % Bandwidth of PRS in resource blocks
    enb{i}.IPRS = 0;                 % PRS configuration index
    enb{i}.PRSPeriod = 'On';         % PRS present in all subframes
    enb{i}.Position = hPositioningPosition(i-1, NeNodeB)/4; % eNodeB position
end

```

Figure 5: *eNodeB* configurations from matlab with parameters [68]

4.1.2 Plot Position of Mobile Base station and User Equipment

Base stations and user equipment spots are contrived for orientation. The user equipment deceits at (0,0) and the base stations are dispersed round the user equipment.

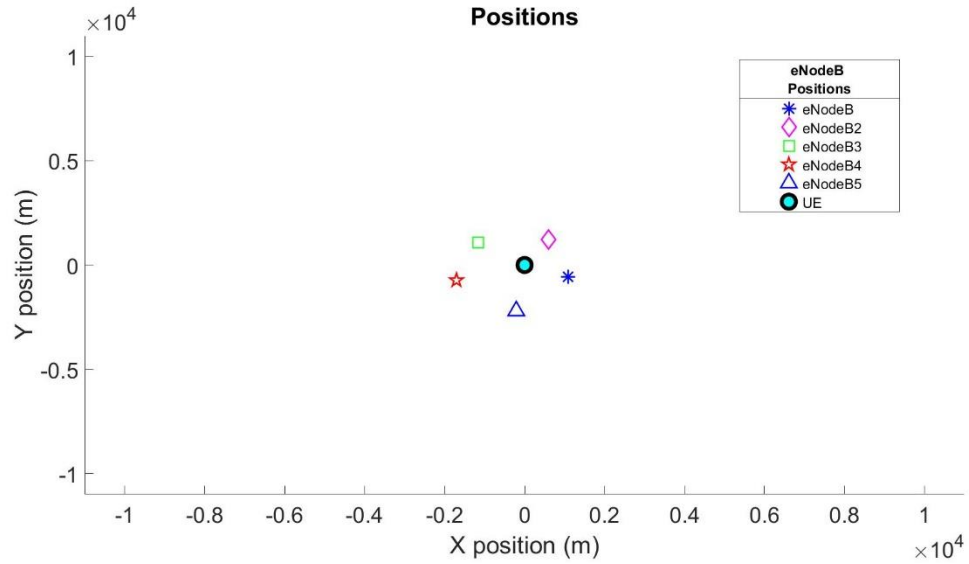

Figure 6: Plot location of eNodeB's and UE

Figure 6 illustrates the positions of the eNodeB's and user positions. The user equipment (UE) measures the time of arrival of signals received from multiple base stations. The time of arrivals from several neighbor eNodeB's are subtracted from a time of arrival of a reference eNodeB to form time difference of arrivals.

Each time difference determines a hyperbola, and the point at which these hyperbolas intersect is the desired user equipment location

4.1.3 PRS Configuration

PRS have been designed so there is no data transmission when a base station transmits PRS signals. As a result, PRS only suffers interference from other PRSs transmitted on the same frequency. Different references provide examples of PRS transmission patterns in positioning subframes. To exploit the high detection capability of the PRS, the network needs to be synchronized to 5G frame boundaries, and the PRS occasions for all base stations on one frequency layer need to be aligned in time. Specifically, this means the same number of PRS subframes N_{PRS} in each positioning occasion for each cell on the same frequency layer, and the same PRS periodicity T_{PRS} for each cell on the same frequency layer.

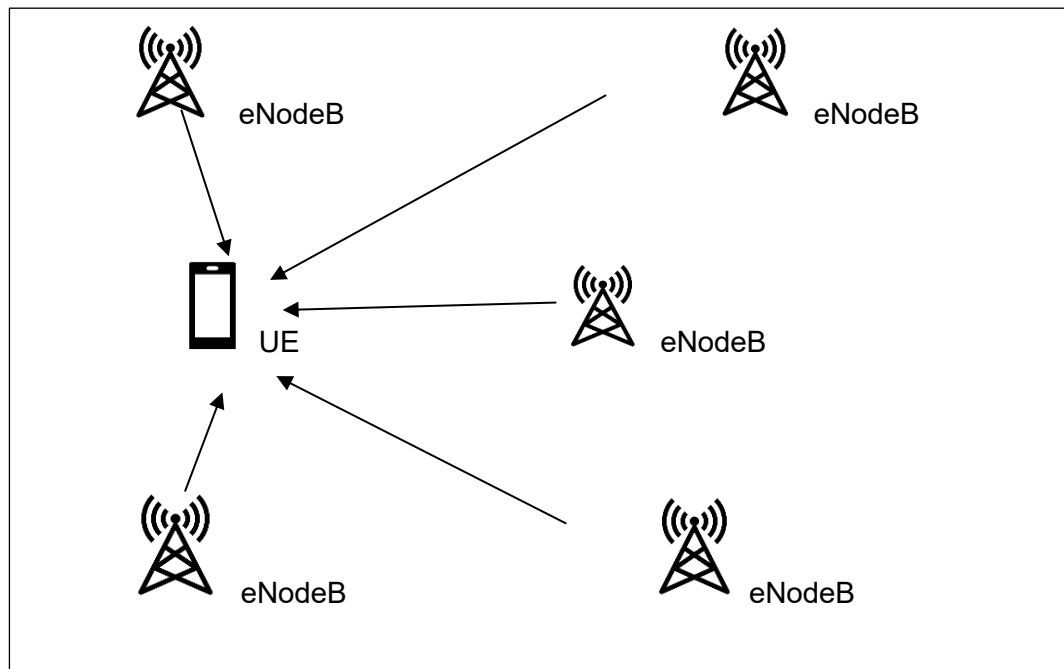

Figure 7: PRS sent by eNodeB's

4.1.4 Broadcast Generating

For each base station component, a broadcast is completed containing of the positioning reference signal, primary synchronization signal, cell-specific reference signal, and secondary synchronization signal. An unfilled reserve network is shaped along with a reference signal generation and charted on the network via resource of PRS besides PRS indices. The Cell RS, PSS and secondary synchronization signal are combined in a comparable way.

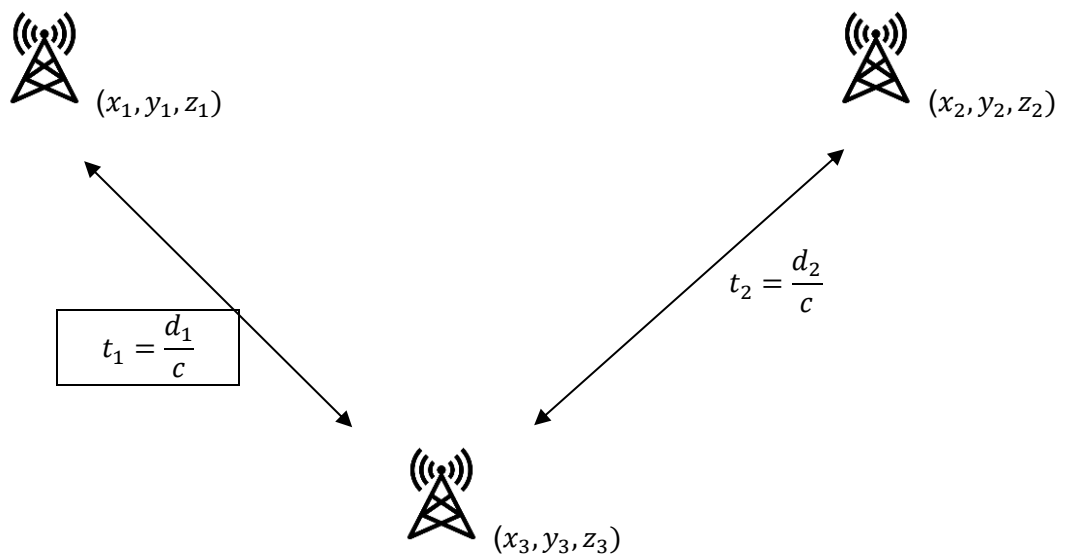

Figure 8: Base stations with their positions

Figure 8 demonstrates the position of the base stations with (x_1, y_1, z_1) , (x_2, y_2, z_2) , (x_3, y_3, z_3) . Time of arrival between base stations being calculated with the help of distance and the light of speed (c), and written as $t_1 = \frac{d_1}{c}$ and $t_2 = \frac{d_2}{c}$.

```

tx = cell(1,NeNodeB);
for i = 1:NeNodeB
    grid = [];
    for nsf = 0:19
        enb{i}.NSubframe = mod(nsf,10);
        sfgrid = lteDLResourceGrid(enb{i}); % Empty subframe
        sfgrid(ltePRSIndices(enb{i})) = ltePRS(enb{i}); % PRS REs
        sfgrid(ltePSSIndices(enb{i})) = ltePSS(enb{i}); % PSS REs
        sfgrid(lteSSSIndices(enb{i})) = lteSSS(enb{i}); % SSS REs
        sfgrid(lteCellRSIndices(enb{i})) = lteCellRS(enb{i}); % Cell RS REs
        grid = [grid sfgrid]; %#ok<AGROW>
    end
    enb{i}.NSubframe = 0;
    tx{i} = lteOFDMModulate(enb{i}, grid); % OFDM modulate

    tx{i} = sqrt(tx_power)*tx{i}/std(tx{i});
    % tx_power(i) = 10*log10(mean(abs(tx{i})^2));
end
set(gca,'fontSize',28)

```

Figure 9: Broadcast generation from MATLAB [68]

4.1.5 Computing delays from base station to UE's

By means of the known base station component locations, the time interruption as of respective base station component to the user equipment is being calculated by means of the distance between *eNodeB* and UE, speed of propagation (speed of light), and the radius. Consuming knowledge of the sample/specimen rate, the model for the delay is intended and stored. The versatile going to cast-off prototyping the environment among the component of base station and the component of user equipment while information won't be provided to user equipment.

```

%% Compute Delays from eNodeBs to UEs
speedOfLight = 299792458.0; % Speed of light in m/s

sampleDelay = zeros(1, NeNodeB);
radius = cell(1, NeNodeB);
for i = 1:NeNodeB
    [~, radius{i}] = cart2pol(enb{i}.Position(1), enb{i}.Position(2));
    delay = radius{i}/speedOfLight; % Delay in seconds
    sampleDelay(i) = round(delay*info.SamplingRate); % Delay in samples
end
set(gca,'fontSize',28)

```

Figure 10: Computing delays from eNodeB's to UE's [68]

4.1.6 Quantity of Established Waveforms and Plot Conventional Waveforms

The established indicator at the user equipment is modeled by delaying individually base station component broadcast rendering to the standards in delay sample, besides lessening the conventional signal beginning with individual base station equipment by means of the values in radius and aggregation with an execution of TR 36.82. The execution process for the path loss model named as urban macro line of sight.

The established waveform from individual base station is amplified by zeros to confirm entire waveform has the similar span.

4.1.7 Accomplishing Cell Search and Launching Cell Identities

Multicell exploration is performed with the aim of identifying the compartment distinctiveness of each base station. Arrangement of shapes for base station component is then shaped founded on the sensed compartment identities also pretentious that the positioning reference signal formation has been provided through advanced-layer signaling which is known to the user equipment. A sum of added physical layer constraints such as the cyclic prefix dimension and duplex mode are expectedly identified and is imaginary to be similar for all base station components.

```

% Plot received waveforms

hPositioningPlotRx(enb, rx, info.SamplingRate); %%
% Assumed parameters for cell search
searchcfg.CyclicPrefix = enb{1}.CyclicPrefix;
searchcfg.DuplexMode = enb{1}.DuplexMode;
searchcfg.NDLRB = enb{1}.NDLRB;

% Perform multi-cell search
searchalg.MaxCellCount = NeNodeB;
searchalg.SSSDetection = 'PostFFT';
[cellIDs,offsets] = lteCellSearch(searchcfg,sumrx,searchalg);

% Set up configurations for each detected cell; cells are considered as
% detected here if they meet a minimum RSRQ threshold Qqualmin
Qqualmin = -20;
RSRQdB = zeros(1,searchalg.MaxCellCount);
rxcfg = cell(1,searchalg.MaxCellCount);
for i = 1:searchalg.MaxCellCount
    % Assumed parameters
    rxcfg{i} = enb{1};
    % Use cell identity that was detected
    rxcfg{i}.NCellID = cellIDs(i);
    % Measure RSRQ
    rxgrid = lteOFDMDemodulate(rxcfg{i},sumrx(1+offsets(i):end,:));
    meas = hRSMeasurements(rxcfg{i},rxgrid);
    RSRQdB(i) = meas.RSRQdB;
end

```

Figure 11: Accomplishing cell search and launching cell identities [68]

4.1.8 Computed Time Difference of Arrival

The time of arrival for the signals from each base station component are recognized at the UE by association of incoming signal with a limited PRS generated with the cell character of each base station component. Letter that the absolute influx times cannot be used at the user equipment to estimate its position as it has no acquaintance of how far away the base station components are, only the alteration in distances specified by the variance in arrival times. Hence, the crowning correlations for each base station components are used as a delay approximation to allow contrast.

Figure 12 illustrates the PRS correlation for detected cells at the location of user equipment. Due to PRS nature, there will be lateral lobes beside the foremost peaks for higher SNR. These side slices can be reflected as the main basis of probable exposure errors for high SNR values.

Therefore, the detection threshold should be based on both noise level and contribution of side lobes from nearby peaks to achieve a robust noise suppression for all SNR values.

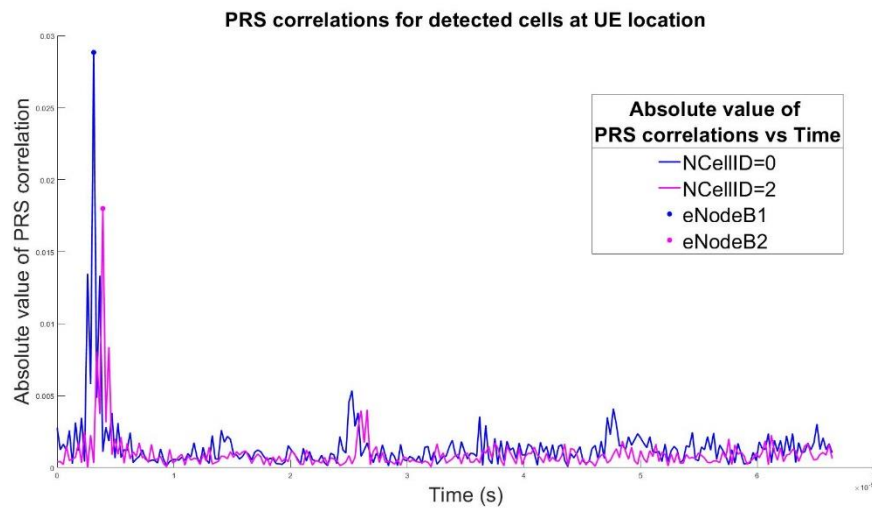

Figure 12: PRS correlations for detected cells at UE location for eNodeB 1 and 2

Beholding at the information among absolute value and time, for both the *eNodeB 1 and 2* lies in between of 0 and 1 with an absolute value of 0.0220 and 0.016 respectively.

Figure 13 shows that there was a sequential decrease in the absolute value up to $1 * 10^{-5}s$ time for each *eNodeB*, while the absolute value vs time doesn't provide much fluctuation up to $7 * 10^{-5}s$.

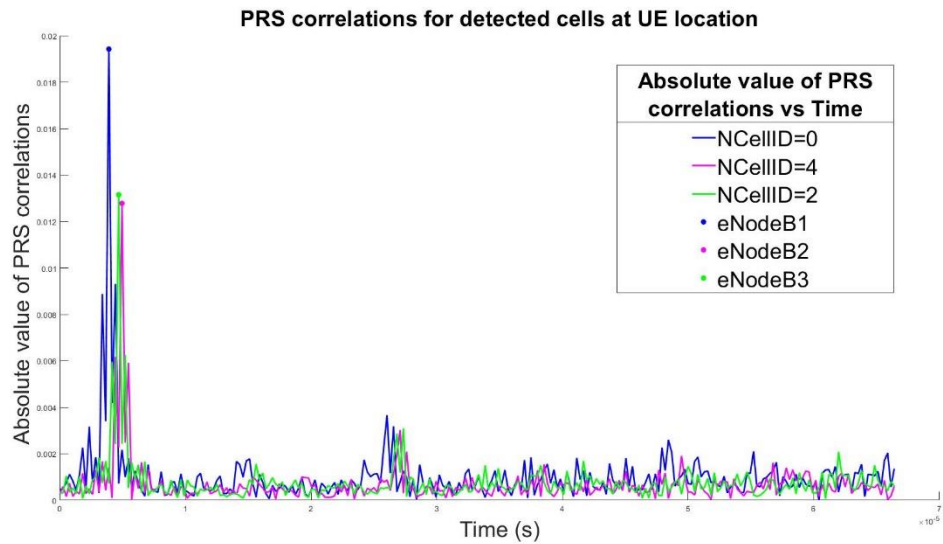

Figure 13: PRS correlations for detected cells at UE location for eNodeB 1 and 2

Observing figure 13, it can be concluded for each base station component that noise is seen as the main error contributor for low SNR values. And side slices are the probable exposure errors for high SNR values.

4.1.9 Computing TDOA and design frequent TDOA hyperbolas

By means of the arrival times, time differences of arrival among every pair of base station component are computed using a MATLAB file.

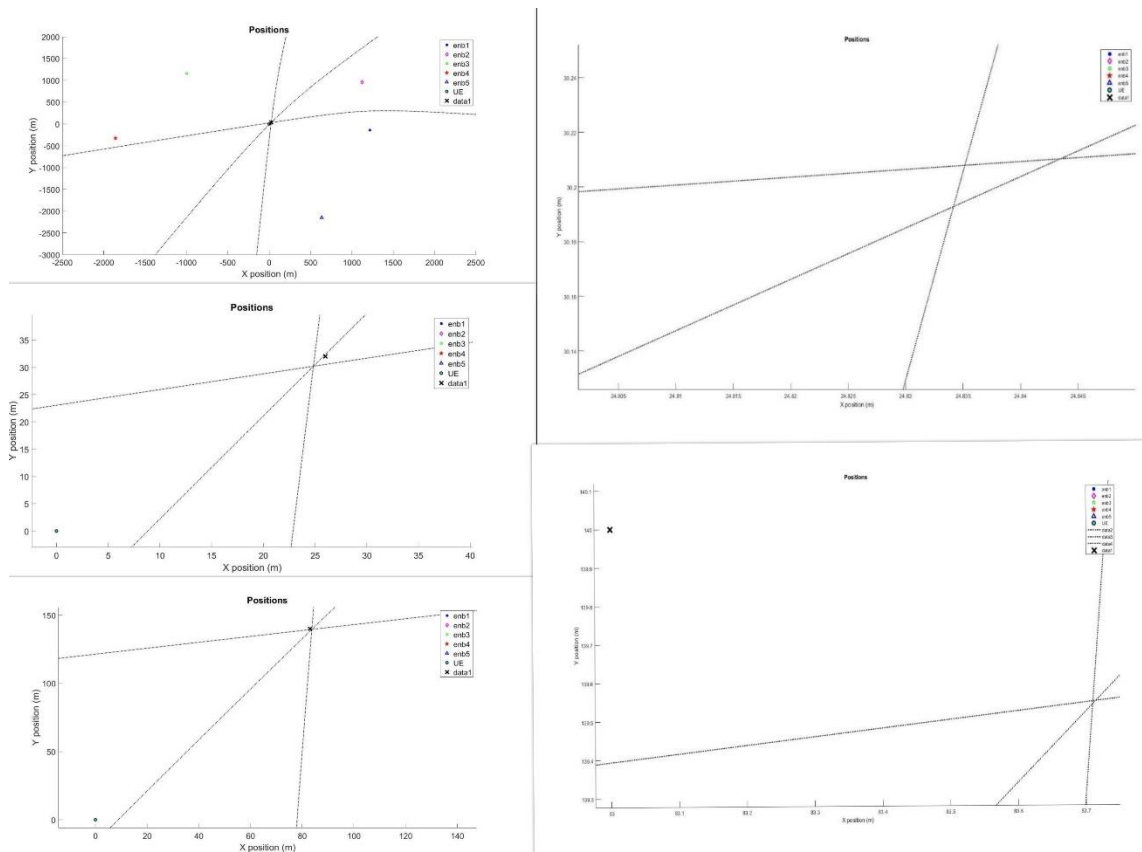

Figure 14: Different view of the positions with different Tx power

In figure 14, we can observe the different view of the positions for different Tx power. The positions of the user equipment get differ for each single different value.

The precise time variance of arrival among a pair of base station components can result from the user equipment being situated at any position where two circles, each centered on a base station component, intersect. Two circles have extents which diverge by the distance shielded at the speed of light in the assumed time difference.

Complete set of conceivable UE positions diagonally all possible radiuses for one circle forms a hyperbola. The "hyperbolas of constant suspension difference" for all the diverse pairs of base station components are plotted comparative to the known base station components positions and crisscross at the position of the user equipment.

5. SIMULATION BASED RESULTS

The selection of the *PRS* signals in 5G and different bandwidths are tradeoff between performance and overhead. The UE intra-frequency *RSTD* measurement performance requirements are specified in *3GPP TS 36.133* [08].

From the *PRS* signals in 5G-NR table, which gives the best tradeoff between performance and overhead with different bandwidths to obtain the specific minimum performance. Increasing T_{PRS} would reduce the overhead but it would then also increase the *UE* response time.

The idea of Monte Carlo algorithm is to generate replications of the model and repetitively solving the problem with varying input parameter(s) [48].

Monte Carlo technique is used to study the responds to the model and randomly generated inputs. It works in a three-stage process:

- Arbitrarily generated “*N*” inputs.
- Consecutively a simulation for individual “*N*” time inputs. Replications are going to track on a computerized system being evaluated.
- Aggregating and assessing the productivities from the replications, common measure contains mean value of an output, distribution of productivity standards, and the least or determined output values.

Diverse and higher bandwidth provides different signal to noise ratio (*SNR*) and root means square error (*RMSE*) value depending on many factors and obstacles.

Before the simulations and experiments, the definition of the *SNR* and the evaluation index are given. *SNR* of the signal is defined as:

$$SNR = 10 \log_{10} \left(\frac{P_{signal}}{P_{noise}} \right)$$

SNR is defined as the ratio of signal power to the noise power, often expressed in decibels. A ratio higher than 1:1 (greater than 0 dB) indicates more signal than noise [67].

Therefore, if the *SNR* is known in advance, the variance of the noise can be obtained. Otherwise, when the *SNR* is not known in advance, the variance of noise has to be attained using the approximate method. The performance index of the receiver is usually known according to the specifications or can be measured by testing.

The arrival time of signal's was measured by the receiver. Assuming that the measurement error targeting at the time of arrival of different receivers is no more than $\Delta\hat{t}_i = (i = 1, 2, \dots M)$, where M denotes the number of the receivers. Let's assume the time difference of arrival between $eNodeB_1$ and $eNodeB_i$ is $\Delta t_{i,1}$.

Then we can get,

$$\Delta t_{i,1} = |t_1 - t_i|$$

where t_1 and t_i denote the measured values when the signal arrives at the base station $eNodeB_1$ and $eNodeB_i$, respectively.

The variance of the noise of $\Delta t_{i,1}$ can be approximated to $\sigma_i^2 = c^2(\Delta\hat{t}_1^2 + \Delta\hat{t}_i^2)$, where c represents the propagation velocity of the signal. The localization performance was evaluated referring to the root mean square,

$$RMSE = \sqrt{\frac{1}{N} \sum_{i=1}^N (\hat{x}_i - x)^2 + (\hat{y}_i - y)^2 + (\hat{z}_i - z)^2}$$

where N represents the number of simulations times, (x, y, z) are the real position coordinates of the target and $\hat{x}_i, \hat{y}_i, \hat{z}_i$ are the estimated positions based on the i^{th} calculations.

RMSE was used to measure the average coordinate distance between the estimated target position and the actual target position. The lower *RMSE*, the higher accuracy it is.

5.1 Analysis with Different Bandwidth of PRS in resource blocks

The subsequent plot (Figure 15) illustrates the effects of bandwidth of PRS in resource blocks, from 0 dB to 60 dB for different number of bandwidths.

Over the period, it can be observed that there was a successive decrease in the *RMSE*, while the signal to noise (*SNR*) value was increasing for different transmission value and there was significant change due to the different bandwidth of 38.4 MHz and 36.2 MHz.

For bandwidth values 38.4 MHz with $N_{PRSRS} = 15$ and 36.2 MHz with $N_{PRSRS} = 12$, the *RMSE*, value and signal to noise value was almost close when the *RMSE* was nearly about 200m and SNR 09 dB. There was a small fluctuation in 36.2 MHz when the SNR was close to 32 dB, while the $N_{PRSRS} = 15$ remains progressive. Later, the *RMSE* was 0.84m and SNR 47.04 dB for 38.4 MHz, while the *RMSE* and SNR was different for 36.2 MHz, which was 0.79m and SNR 54.22 dB respectively.

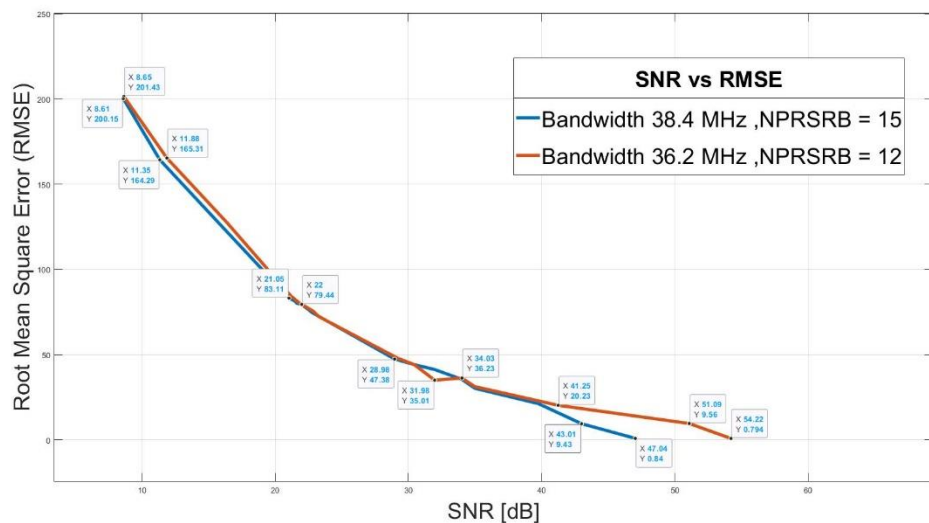

Figure 15: SNR vs RMSE with a Bandwidth of 38.4 MHz and 36.2 MHz

Looking at the information by level of different bandwidth, it reveals that higher levels of *RMSE* corresponds to lower levels of SNR in both of those 38.4 MHz and 36.2 MHz bandwidths.

The below figure 16 set forth the effects of number of 38.4 MHz and 35.1 MHz bandwidths for 0 dB to 60 dB SNR values. It can be said that there was a decrease in the root mean square error (RMSE), while the SNR (signal to noise) value was increasing except some fluidity and there was significant change due to the different bandwidths.

For both 38.4 MHz and 35.1 MHz, the root means square error (RMSE) and signal to noise (SNR) value was almost 200m and SNR 8.6 dB. Among of several perturbation, SNR 22 dB, 34 dB and 40 dB has to be in count as 38.4 MHz and 35.1 MHz , both curves compounded in these levels of SNR.

After some perturbation, both 38.4 MHz and 35.1 MHz gained different RMSE and SNR. The RMSE was 0.84m and SNR 47.04 dB for 38.4 MHz and RMSE 0.89m and SNR 58.21dB for 35.1 MHz .

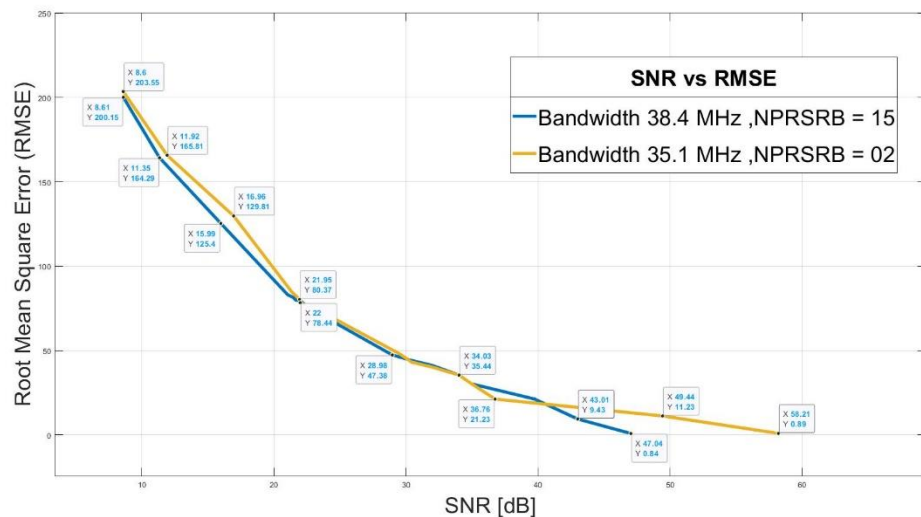

Figure 16: SNR vs RMSE with a Bandwidth of 38.4 MHz and 35.1 MHz

Figure 17 expresses and compares the differences for 36.2 MHz and 35.1 MHz bandwidths, for $-05m$ to $210m$ RMSE values.

Comparing both plots, it is observed that SNR value was increasing while there was a decrease in the RMSE except some mutability.

In cooperation, both bandwidths 36.2 MHz and 35.1 MHz, the root means square error (RMSE) and signal to noise ratio (SNR) value was nearly $200m$ and SNR 8.6 dB. After several agitation, SNR 21 dB, 30 dB and 50 dB has to be in count as $N_{PRRS} = 12$ and $N_{PRRS} = 02$, both curves composited in these levels of SNR.

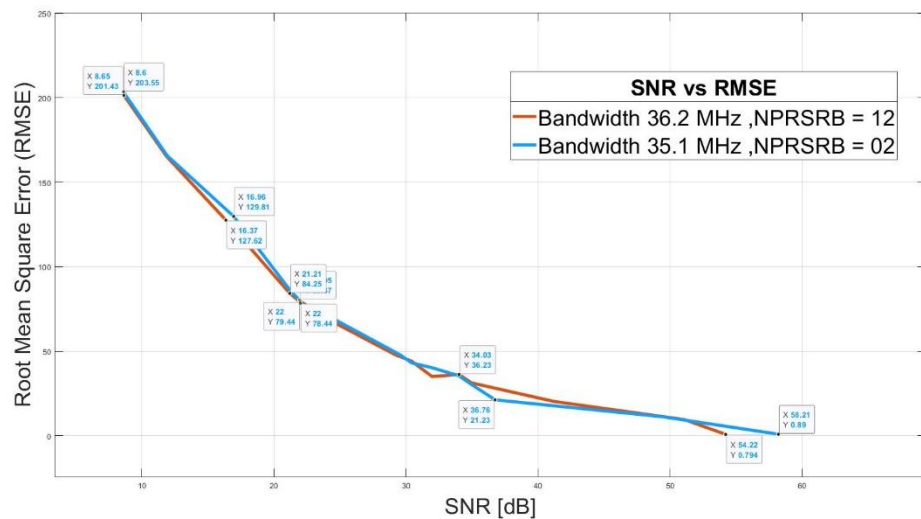

Figure 17: SNR vs RMSE with a Bandwidth of 36.2 MHz and 35.1 MHz

Finally, after some trepidation, $N_{PRRS} = 12$ and $N_{PRRS} = 02$ comes with different RMSE and signal to noise ratio. For both N_{PRRS} and different Bandwidth the RMSE was below $1m$ and SNR was above $50dB$.

Figure 18 unravel the effects of number of bandwidths for a consecutive number of, 38.4 MHz, 36.2 MHz and 35.1 MHz, for different RMSE and SNR values.

Comparing all the effects for different bandwidths and N_{PRSRB} , it is clear that there was a meaningful decrease in the RMSE and momentous increase in the signal to noise.

The starting point of different bandwidths and N_{PRSRB} started without much difference in RMSE and SNR, and at a point of 22dB and 79.44m all these curves for different parameters kneading each other. After that, there were fluctuation and at a point around 40dB and 35m, bandwidths of 38.4 MHz and 35.1 MHz has almost same value than 36.2 MHz.

After some mild agitation, bandwidths of 38.4 MHz, 36.2 MHz and 35.1 MHz gained different RMSE (root mean square error) and SNR. Finally, the RMSE was 0.84m and SNR 47.04 dB for $N_{PRSRB} = 15$, RMSE 0.79m and SNR 54.22dB for $N_{PRSRB} = 12$ and RMSE 0.89m and SNR 58.21dB for $N_{PRSRB} = 02$.

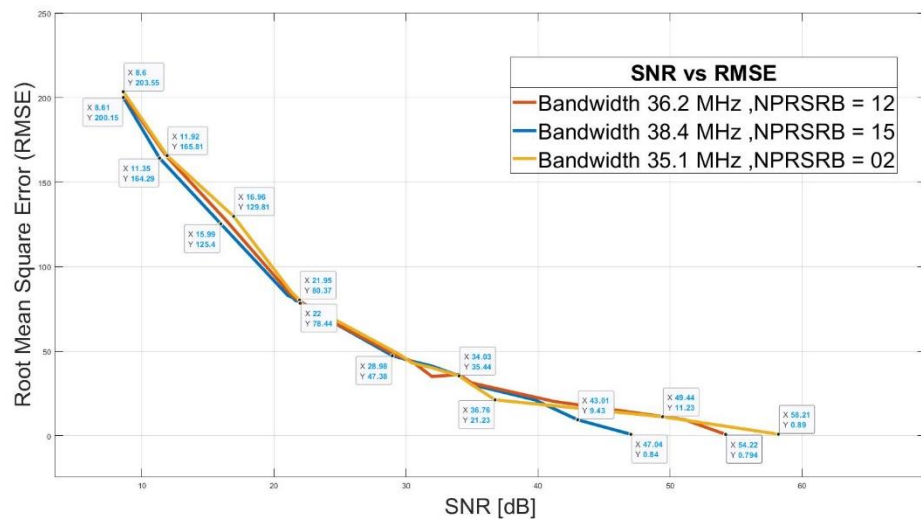

Figure 18: SNR vs RMSE with a Bandwidth of 38.4 MHz, 36.2 MHz and 35.1 MHz

To conclude, it can be mentioned that there have been considerable climbs in SNR for all the different bandwidth along with PRS in resource blocks.

5.2 Performing analysis with different Sample Size

Figure 19 compares both sample size, $N = 600$ and $N = 700$ for the signal to noise ratio and Root Mean Square Error, it is detected that Root Mean Square Error was decreasing while SNR value was increasing except some mutability.

In cooperation $N = 600$ and $N = 700$, the RMSE and SNR value was approximately $200m$ and SNR 8.65 dB . After several agitation, SNR 25 dB , 42 dB and 47 dB has to be in count as $N = 600$ and $N = 700$, both curves amalgamated in these levels of SNR.

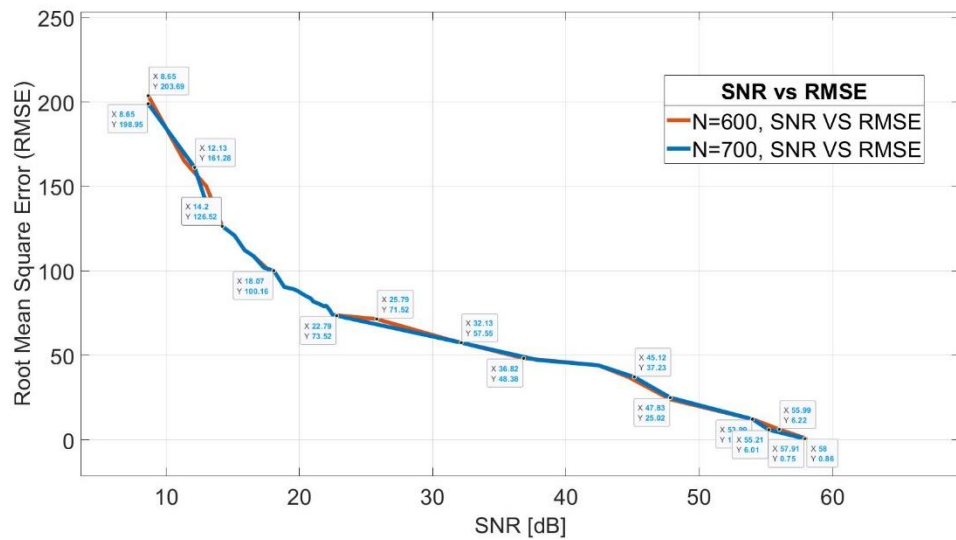

Figure 19: SNR VS RMSE with Sample Size, $N=600$ and $N=700$

Lastly, after some apprehension, $N = 600$ and $N = 700$ comes with different RMSE and signal to noise ratio. For both Sample Size, the RMSE was below $1m$ and SNR was nearly 57 dB .

In figure 20, we can observe that root mean square error was decreasing while SNR value was increasing except some flexible move.

Both $N = 500$ and $N = 700$, provides a value close to the $200m$ for RMSE and 8.65 dB for SNR.

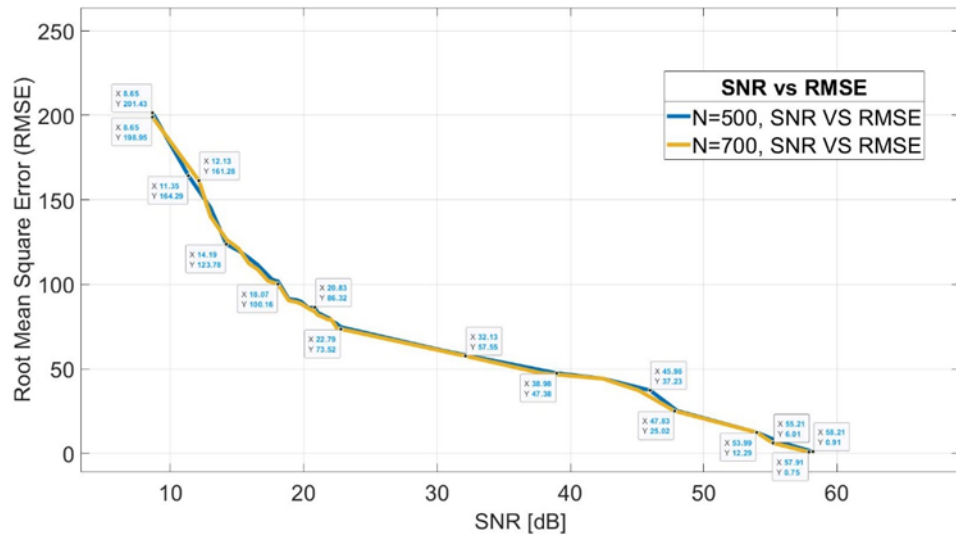

Figure 20 : SNR VS RMSE with sample size, $N=500$ and 700

Finally, $N = 500$ and $N = 700$ comes with diverse SNR and RMSE. For the RMSE was below $0.91m$ and SNR was nearly 58 dB for $N = 500$ and $0.75m$ and 57.91 dB for $N = 700$.

Figure 21 unravels the effects of sample size for a consecutive number of $N = 500$, $N = 600$ and $N = 700$, for different RMSE and SNR values.

Associating all these properties for different sample size, it is clear that there was a meaningful decrease in the RMSE and momentous increase in the signal to noise.

The starting point of different sample size started without much difference in RMSE and SNR, and at a point of 25dB and 71.52m all these curves for different parameters kneading each other. Later, there were variation and at a point above 40dB and 25m , $N = 500$, $N = 700$ has almost same value than the sample size $N = 600$.

After some tension, $N = 500$, $N = 600$ and $N = 700$, gained different root mean square error and SNR. Finally, the RMSE was 0.80m and SNR was above 50dB for all the different sample size.

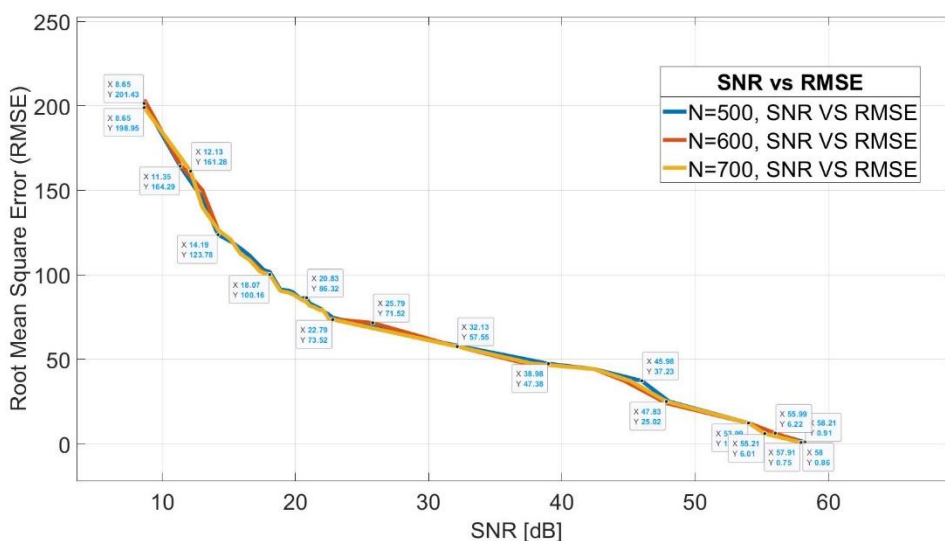

Figure 21 : SNR VS RMSE with sample size, $N = 500, 600$ and 700

In conclusion, it can refer that there have been substantial climbs for all the different sample size.

SNR VS RMSE for different Sample Size			
N = 600		N = 500	
RMSE value	SNR value	RMSE value2	SNR value2
126.52	14.20	123.7842	14.19
120.93	15.13	119.79	15.13
112.26	15.89	115.52	15.89
108.79	16.55	111.48	16.54
100.99	17.62	102.76	17.62
90.48	18.86	91.35	18.85
89.34	19.52	90.53	19.52
88.40	19.81	89.69	19.81
85.79	20.35	85.95	20.35
83.84	20.83	86.32	20.83
80.58	21.46	81.55	21.46
79.02	21.84	80.07	21.84
79.49	22.00	79.44	22.00
76.91	22.26	77.86	22.17
76.37	22.49	76.91	22.42
74.16	22.79	74.62	22.79

Table 4: SNR VS RMSE when Sample Size, $N = 600$ and $N=500$

5.3 Investigation of Received waveforms at UE Locations

Resulting figures are representing the potential solutions to the problems of positioning. Their atmospheres are color-coded (green, red, blue) in accordance by which explanation these neighbors congregate on.

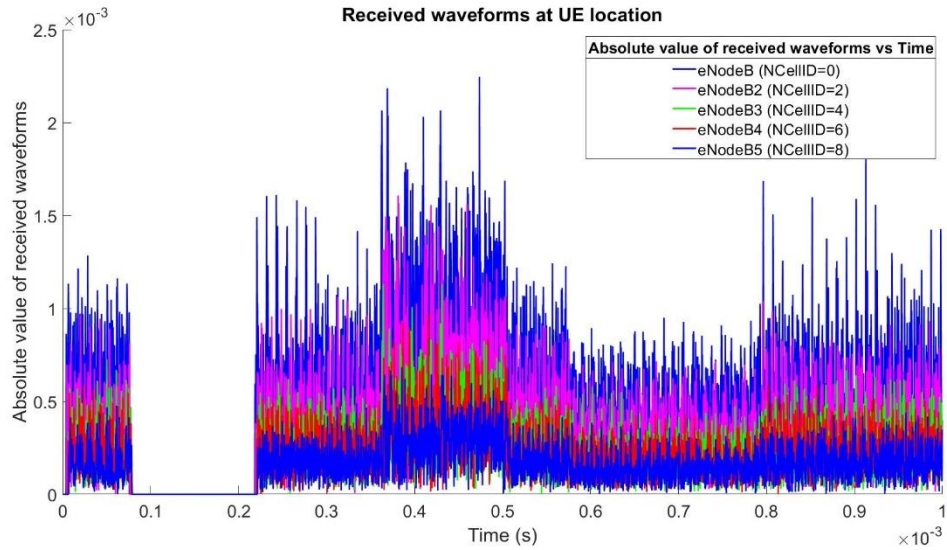

Figure 22: Received waveforms at UE locations

Figure 22 demonstrates the received signal at the UE is modeled by delaying each eNodeB transmission according to the values in sample delay, and attenuating the received signal from each eNodeB using the values in radius in conjunction with an implementation of the TR 36.814 [68] urban macro line of sight (LOS) path loss model. The received waveform from each eNodeB is padded with zeros to ensure all waveforms has the same length.

6. CONCLUSION AND FUTURE WORKS

The simulation work demonstrated that the time difference of arrival (TDOA) method is effective in improving the position estimation for 5G. The mean location fault was abridged in respect to the *TDOA* multilateracies, reducing the signal to noise ratio at the same time.

The results showed also that three base stations are enough to obtain good measurements, while the simulation was performed with five base station components for better output. With the help of three base stations, sometimes it's really hard to achieve an accuracy below $1m$ for RMSE whereas five base station works well. The gained RMSE with TDOA method was $0.79m$ with five base stations. *TDOA* accuracy for 5G is sturdily devoted to the excellency of assumption.

Performing analysis with the different bandwidth of $38.4 MHz$, $36.2 MHz$ and $35.1 MHz$ and comparing all the analysis, it is indisputable that there was a meaningful decrease in the RMSE and momentous increase in the noise. The higher bandwidth brings higher noise while the SNR was lower and lower bandwidth provides higher noise with lower SNR values. The positivity of the analysis with different bandwidth reveals keeping the RMSE value lower than a meter each time with different statistics. Among of all analysis, a bandwidth of $38.4 MHz$ performs better than a bandwidth of $35.1 MHz$, where we have found the accuracy lower than a meter with SNR of $47.04 dB$.

Another execution analyzed with different sample size and associating all the analysis with different sample size, the decrease in the root mean square error and crucial upsurge in the signal to noise ratio was observed. The execution was analyzed for the sample size of $N = 500, 600$ and 700 . For each higher sample size performed well for the analysis of *RMSE vs. SNR*.

Among of other influences related for achieving high-accuracy TDOA namely timing accuracy, network geometry, different types of obstacles etc. One important feature that was found is the higher bandwidth. Furthermore, it is vital to remind the fact of PRS frequency and cyclic prefixes along with bandwidth.

This time difference of arrival considers a procedure to exploit the abilities of the algorithms without considering the presence of errors due to signal broadcast, synchronization of the system or signal processing. For this purpose, in forthcoming works it is

needed to consider optimization in a framework where a non-line-of-sight (NLOS) scenario exists, clock synchronization is well-thought-out and other belongings related to node dispersal are also considered.

To conclude, it can be said that higher bandwidth plays a vital role gaining an accuracy lower than a meter. Also, it's impossible to accomplish whether the time difference of arrival method can be fruitful to positioning schemes by means of enough nodes and sufficient assurance to pledge the correct estimation of the position. However, it's probable to encourage that uninterrupted estimation techniques do pledge towards one of the best accuracy possible. This methodology with the developed sample size along with higher bandwidth and PRS signals ultimately provides countless progresses to the positioning system possessions used all over the thesis.

The analysis obtained in this work can be prolonged in a plethora of ways and adapted to many dissimilar scenarios. First and foremost, the algorithm, being based on knowledge and no supposition about the network, is disposed to adapt different surroundings and situations. Secondly, higher bandwidth and PRS signals variant unlocks the way to even more competences and possible postponements [45]. Not only the range-based regions, but also angle-based regions are possible to define or even better. Moreover, it is likely to exploit machine learning even more by allowing the classification of these regions to the system itself. One method to attain this would be the use of clustering of the channel prejudice over space instead of clustering over time. This style can be improved to *IoT* and ultra-wide band (*UWB*) signals wherever recurrent reflections easily worsen the position estimation.

7. REFERENCES

- [1] Isaac K Adusei, K. Kyamakya, Klaus Jobmann "Mobile Positioning Technologies in Cellular Networks: An Evaluation of their Performance Metrics"
- [2] E. Damosso, —Digital Mobile Radio towards Future Generation Systems, II 1999. [Online]. Available: http://kom.aau.dk/antprop/pub/cost231_dot.html.
- [3] S. Cui; A. J. Goldsmith & A. Bahai (August 2004). "Energy-efficiency of MIMO and Cooperative MIMO in Sensor Networks". IEEE Journal on Selected Areas in Communications. 22 (6): 1089–1098.
- [4] E. Ezhilarasan and M. Dinakaran, 'a review on mobile technologies: 3G, 4G and 5G', 2017. Second International Conference on Recent Trends and Challenges in Computational Models. [2017]
- [5] V. Quintuna-Rodriguez and F. Guillemin. 2017. VNF modeling towards the cloud-RAN implementation in Networked Systems (NetSys), 2017 International Conference on. IEEE, 1–8
- [6] Thorpe M., Kottkamp M., Rössler, A. Schütz J.: LTE Location Based Services Technology introduction. Rohde & Schwarz (April 2013)
- [7] Fischer, S.: Observed Time Difference of Arrival (OTDOA) Positioning in 3GPP LTE Qualcomm Technologies (June 2014).
- [8] 3GPP TS 36.211 V12.3.0. LTE; Evolved Universal Terrestrial Radio Access (E-UTRA); Physical channels and modulation (3GPP TS 36.211 version 12.3.0 Release 12), (October 2014).
- [9] Del Peral-Rosado, J.A., Lopez-Salcedo, J.A., Seco-Granados, G., Zanier, F., Crisci, M.: Achievable localization accuracy of the positioning reference signal of 3GPP LTE. In: Proceedings of International Conference on the Localization and GNSS (ICL-GNSS), pp. 1-6. IEEE, Starnberg (2012).
- [10] T. Kos, M. Grgic, and G. Sisul, "Mobile user positioning in GSM/UMTS cellular networks," in Multimedia Signal Processing and Communications, 48th International Symposium ELMAR-2006, 2006, pp. 185–188
- [11] Parkinson, B. W. (1996). Progress in astronautics and aeronautics: Global positioning system: Theory and applications (Vol. 2).
- [12] Shi, G., & Ming, Y. (2016). Survey of Indoor Positioning Systems Based on Ultra-wideband (UWB) Technology. In Wireless Communications, Networking and Applications (pp. 1269-1278). Springer India.

- [13] S.P. Drake and K. Dogancay, "Geolocation by Time Difference of Arrival Using Hyperbolic Asymptotes," Proc. IEEE Int'l Conf. Acoustics Speech and Signal Processing (ICASSP), 2004
- [14] E. Laitinen, E. S. Lohan, J. Talvitie and S. Shrestha, "Access point significance measures in WLAN-based location" 2012 9th workshop on positioning, navigation and communication, Dresden, pp. 24-29, 2012
- [15] J. Nachtigall, A. Zubow, and J.-P. Redlich, "The Impact of Adjacent Channel Interference in Multi-Radio Systems using IEEE 802.11," in 2008 International Wireless Communications and Mobile Computing Conference. IEEE, 2008, pp. 874–881.
- [16] D. B. Faria and D. R. Cheriton, "Detecting identity-based attacks in wireless networks using singalprints," in Proceedings of WiSe'06: ACM Workshop on Wireless Security, Sept. 2006, pp. 43–52
- [17] Chuang, J. C-I. "The effects of time delay spread on portable radio communications channels with digital modulation" IEEE I. Selected Areas in Communications, June 1987, pp 879-889
- [18] Bello, P. A. "Characterization of randomly time-variant linear channels" IEEE Transactions on Communication Systems. vol CS-11, pp 36-393, Dec 1963
- [19] Lee. W. C. Y. "Mobile Communications Engineering" (McGraw-Hill. 1982)
- [20] Proakis. J. G. "Digital Communications (3rd Ed.)" (McGraw-Hill, 1995)
- [21] Burr, A. G. "Multilevel modulation and coding for indoor radio channels" IEE Colloquium on " "Radio LWs and MANS", London, 6th April 1995. IEEE Digest no. 1995/071"
- [22] T. S. Rappaport et al., "Millimetre wave mobile communications for 5G cellular: It will work!" IEEE Access, vol. 1, pp. 335–349, 2013
- [23] M. Pratap and E. Per, "Global Positioning System: Signals, Measurements and Performance," 2nd Edition, Ganga Jamuna Press, New York, 2006.
- [24] E. L. Akim and D. A. Tuchin, "GPS Errors Statistical Analysis for Ground Receiver Measurements," Keldysh Institute of Applied Mathematics, Russia Academy of Sciences, 2002.
- [25] Balanis Constantine A, Panayiotis I. Ioannides. Introduction to smart antennas United States: Morgan & Claypool Publishers; 2007.
- [26] V. Inzillo, F.De Rango, L. Zampogna and Alfonso A. Quintana, "DOI: 10.5772/intechopen.79933", Smart Antenna Systems Model Simulation Design for 5G Wireless Network System, November 5th 2018

- [27] Z. Xiao, H. Wen, and A. Markham, "Identification and mitigation of non-line-of-sight conditions using received signal strength," University of Oxford, Department of Computer Science, 2010.
- [28] Chen, S.H., Mitra, U. and Krishnamachari, B. (2005) 'Cooperative communication and routing over fading channels in wireless sensor networks', *Wireless Com*, 2005.
- [29] A. Abdi, C. Tepedelenlioglu, G. B. Giannakis, and M. Kaveh, "On the estimation of the parameter for the Rice fading distribution," *IEEE Commun. Lett.*, vol. 5, pp. 92–94, Mar. 2001.
- [30] J. Moore, H. Ling, "Super-Resolved Time-Frequency Analysis of Wideband Backscattering Data", *IEEE Transaction on Antennas and Propagation*, vol. 43, no. 6, June 1995.
- [31] Lawrence H. Ozarow, Shlomo Shaimai, Aaron D. Wyner "Information Theoretic Considerations for Cellular Mobile Radio", *IEEE Trans. on Vehic. Technol.*, Vol.43, No.2, May 1994.
- [32] R. K. Martin, J. Velotta, and J. Raquet, "Bandwidth efficient cooperative TDOA computation for multicarrier signals of opportunity," *IEEE Trans. Signal Process*, vol. 57, no. 6, pp. 2311–2322, Jun. 2009
- [33] Richard K. Martin, Chunpeng Yan, H. Howard Fan, and Christopher Rondeau "Algorithms and Bounds for Distributed TDOA-Based Positioning Using OFDM Signals" VOL. 59, NO. 3, MARCH 2011
- [34] C. Leonel, F. Mayorga, F. D. Rosa, S. A. Wardana, G. Simone, M. C. N. Raynal, J. Figueiras, S. Frattasia; "Cooperative Positioning Techniques for Mobile Localization in 4G Cellular Networks", *Pervasive Services, IEEE International Conference on*, PP. 39-44, 2007
- [35] K. C. Ho, X. Lu, and L. Kovavisaruch, "Source Localization Using TDOA and FDOA Measurements in the Presence of Receiver Location Errors: Analysis and Solution", *IEEE Transactions on Signal Processing*, Vol. 55, No. 2, February 2007
- [36] L. Cong and W. Zhuang, "Non-line-of-sight error mitigation in TDOA mobile location," in *Global Telecommunications Conference, 2001. GLOBECOM '01. IEEE*, vol. 1, 2001, pp. 680-684 vol.1.
- [37] R. K. Martin, J. S. Velotta, and J. F. Raquet, "Multicarrier modulation as a navigation signal of opportunity," in *Proc. IEEE Aerosp. Conf., Big Sky, MT*, Mar. 2008.
- [38] M. Bocquet et al., "Using Enhanced-TDOA Measurement for Indoor Positioning", *IEEE Microw. Wireless Compon. Lett.*, vol. 15, no. 10, pp. 612-614, October 2005.

- [39] C. Knapp, G. C. Carter, "The generalized correlation method for estimation of time delay", *Acoustics Speech and Signal Processing IEEE Transactions on*, vol. 24, no. 4, pp. 320-327, Aug 1976.
- [40] K. Ho, X. Lu, L. Kovavisaruch, "Source Localization Using TDOA and FDOA Measurements in the Presence of Receiver Location Errors: Analysis and Solution", *Signal Processing IEEE Transactions on*, vol. 55, no. 2, pp. 684-696, Feb 2007.
- [41] A. H. Sayed, A. Tarighat, N. Khajehnouri, "Network-based wireless location: challenges faced in developing techniques for accurate wireless location information", *IEEE Signal Processing Magazine*, vol. 22, no. 4, pp. 24-40, July 2005.
- [42] P. Deng, L. G. Yu, "GDOP performance analysis of cellular location system", *Journal of Southwest Jiaotong University*, vol. 40, no. 2, pp. 184-188, April 2005.
- [43] R. Kaune, "Accuracy studies for TDOA and TOA localization", 2012 15th International Conference on Information Fusion, pp. 408-415, 2012.
- [44] S.R. Drake, K. Dogancay, "Geolocation by time difference of arrival using hyperbolic asymptotes", *IEEE Int. Conf. Acoustics Speech and Signal Processing (ICASSP)*, pp. II 361-II 364, 2004.
- [45] Bonan, J.; Xiaosu, X.; Zhang, T. Robust Time-Difference-of-Arrival (TDOA) Localization Using Weighted Least Squares with Cone Tangent Plane Constraint. *Sensors* 2018, 18, 778.
- [46] R. Iyer, L. Kurtz, D. Schneider, J. Zeta: "Small Cells, Big Challenge: A Definitive Guide to Designing and Deploying HetNets," CreateSpace Independent Publishing Platform, Feb. 11, 2014
- [47] Jafar, Syed A. (2010). "Interference Alignment — A New Look at Signal Dimensions in a Communication Network". *Foundations and Trends in Communications and Information Theory*. 7 (1): 1–134.
- [48] Kroese, D. P.; Brereton, T.; Taimre, T.; Botev, Z. I. (2014). "Why the Monte Carlo method is so important today". *WIREs Comput Stat*. 6 (6): 386–392.
- [49] M. Pent, M. A. Spirito, and E. Turco, "Method for positioning GSM mobile stations using absolute time delay measurements," *Electronics Letters*, vol. 33, no. 24, pp. 2019–2020, Nov 1997.
- [50] J. Caffery Jr., "A new geometry approach to TOA location," *IEEE Vehicular Technology Conference (IEEE VTS-Fall 2000)*, vol. 4, 2000, pp. 1943–1949.
- [51] S. Fischer, H. Grubeck, A. Kangas, H. Koorapaty, E. Larsson, P. Lundqvist, "Time of arrival estimation of narrowband TDMA signals for mobile positioning," *IEEE International Symposium on Personal, Indoor and Mobile Radio Communications*, vol. 1, 1998, pp. 451–455

- [52] R. Schmidt, "Multiple emitter location and signal parameter estimation," *Antennas and Propagation, IEEE Transactions on*, vol. 34, no. 3, pp. 276–280, Mar 1986.
- [53] T. S. Rappaport, "Wireless Communications: Principles and Practice" in, Englewood Cliffs, NJ:Prentice-Hall, 1996.
- [54] A. J. Weiss, "On the Accuracy of a Cellular Location System Based on RSS Measurements", *IEEE Transactions on Vehicular Technology*, vol. 52, no. 6, pp. 1508-1518, Nov. 2003.
- [55] R.M Ferre, G.S. Granados, E.S. Lohan "Positioning Reference Signal design for positioning via 5G", National Committee for Radiology in Finland, 2019
- [56] Young, D. P., Keller, C. M., Bliss, D. W., & Forsythe, K. W. (2003, November). Ultra-wideband (UWB) transmitter location using time difference of arrival (TDOA) techniques. In *Signals, Systems and Computers, 2004. Conference Record of the Thirty-Seventh Asilomar Conference on* (Vol. 2, pp. 1225-1229). IEEE
- [57] Studer, E. G. Larsson, "PAR-Aware Large-Scale Multi-User MIMO-OFDM Downlink", *IEEE JSAC*, vol. 31, pp. 303-13
- [58] Li, S., L. Da Xu and S. Zhao (2018). "5G internet of things: A survey." *Journal of Industrial Information Integration* 10: 1-9.
- [59] A. Tikhomirov, E. Omelyanchuk, A. Semenova, (2018). "Recommended 5G frequency bands evaluation" *Conference on Systems of Signals Generating and Processing in the Field of on-Board Communication*, pp. 01-02
- [60]] S. Ćapkun, M. Hamdi, and J. Hubaux, —GPS-free positioning in mobile Ad-Hoc networks, *Iin Proc. of the 34th Hawaii International Conf. on System Sciences*, Jan 2001, pp. 1-10.
- [61] V. Inzillo, F.De Rango, L. Zampogna and Alfonso A. Quintana, "DOI: 10.5772/intechopen.79933", *Smart Antenna Systems Model Simulation Design for 5G Wireless Network System*, November 5th 2018
- [62] REPORT ITU-R SM.2211-2 Comparison of time-difference-of-arrival and angle-of-arrival methods of signal geolocation (2011-2014-2018)
- [63] A. Tahat, G. Kaddoum, S. Yousefi, S. Valaee, A Look at the Recent Wireless Positioning Techniques with a Focus on Algorithms for Moving Receivers, *IEEE Access* 4:6652 - 6680 · September 2016
- [64] B. LeFloch, M. Alard, C. Berrou, "Coded Orthogonal Frequency Division Multiplex", *Proc. IEEE*, vol. 83, pp. 982-996, June 1995.
- [65] Van Hove, L.; McVoy, K.W. (1962). "Pair distribution functions and scattering phenomena". *Nuclear Physics*. Elsevier BV. 33: 468–476. doi:10.1016/0029-5582(62)90539-4. ISSN 0029-5582

- [66] W. S. M. Werner, J. Zemek, P. Jiricek "Distinguishing elastic and inelastic scattering effects in reflection electron energy loss spectroscopy", ResearchGate publication 235558847, published 12 October 2010
- [67] Breeding, Andy (2004). The Music Internet Untangled: Using Online Services to Expand Your Musical Horizons. Giant Path. p. 128. ISBN 9781932340020.
- [68] 3GPP TR 36.814 "Further advancements for E-UTRA physical layer aspects"