

Air Force Institute of Technology

AFIT Scholar

Theses and Dissertations

Student Graduate Works

6-2007

Development of Cursor-on-Target Control for Semi-Autonomous Unmanned Aircraft Systems

Joshua D. Crouse

Follow this and additional works at: <https://scholar.afit.edu/etd>

 Part of the [Aerospace Engineering Commons](#)

Recommended Citation

Crouse, Joshua D., "Development of Cursor-on-Target Control for Semi-Autonomous Unmanned Aircraft Systems" (2007). *Theses and Dissertations*. 2936.
<https://scholar.afit.edu/etd/2936>

This Thesis is brought to you for free and open access by the Student Graduate Works at AFIT Scholar. It has been accepted for inclusion in Theses and Dissertations by an authorized administrator of AFIT Scholar. For more information, please contact richard.mansfield@afit.edu.



**DEVELOPMENT OF CURSOR-ON-TARGET CONTROL FOR
SEMI-AUTONOMOUS UNMANNED AIRCRAFT SYSTEMS**

THESIS

Joshua D. Crouse, Lieutenant, USN
AFIT/GAE/ENY/07-J04

**DEPARTMENT OF THE AIR FORCE
AIR UNIVERSITY**

AIR FORCE INSTITUTE OF TECHNOLOGY

Wright-Patterson Air Force Base, Ohio

APPROVED FOR PUBLIC RELEASE; DISTRIBUTION UNLIMITED

The views expressed in this thesis are those of the author and do not reflect the official policy or position of the United States Air Force, Department of Defense, or the U. S. Government.

AFIT/GAE/ENY/07-J04

**DEVELOPMENT OF CURSOR-ON-TARGET CONTROL FOR
SEMI-AUTONOMOUS UNMANNED AIRCRAFT SYSTEMS**

THESIS

Presented to the Faculty

Department of Aeronautics and Astronautics

Graduate School of Engineering and Management

Air Force Institute of Technology

Air University

Air Education and Training Command

In Partial Fulfillment of the Requirements for the
Degree of Master of Science in Aeronautical Engineering

Joshua D. Crouse, BS

Lieutenant, USN

June 2007

APPROVED FOR PUBLIC RELEASE; DISTRIBUTION UNLIMITED.

AFIT/GAE/ENY/07-J04

DEVELOPMENT OF CURSOR-ON-TARGET CONTROL FOR
SEMI-AUTONOMOUS UNMANNED AIRCRAFT SYSTEMS

Joshua D. Crouse, BS
Lieutenant, USN

Approved:

Paul A. Blue (Thesis Advisor)

date

Richard G. Cobb (Committee Member)

date

David R. Jacques (Committee Member)

date

Abstract

The research presented in this thesis focuses on developing, demonstrating, and evaluating the concept of a Cursor-on-Target control system for semi-autonomous unmanned aircraft systems. The Department of Defense has mapped out a strategy in which unmanned aircraft systems will increasingly replace piloted aircraft. During most phases of flight autonomous unmanned aircraft control reduces operator workload, however, real-time information exchange often requires an operator to relay decision changes to the unmanned aircraft. The goal of this research is to develop a preliminary Cursor-on-Target control system to enable the operator to guide the unmanned aircraft with minimal workload during high task phases of flight and then evaluate the operator's ability to conduct the mission using that control system. For this research, the problem of Cursor-on-Target control design has multiple components. Initially, a Cursor-on-Target controller is developed in Simulink. Then, this controller is integrated into the Aviator Visual Design Simulator to develop an operator-in-the-loop test platform. Finally, a ground target is simulated and tracked to validate the Cursor-on-Target controller. The Cursor-on-Target control system is then evaluated using a proposed operator rating scale.

To my best friend in life

“The nation that draws too great a distance between its soldiers and its scholars will have its children taught by cowards and its fighting done by fools.”

Thucydides, 400 B.C.

“It is not the critic who counts, not the man who points out how the strong man stumbled, or where the doer of deeds could have done better. The credit belongs to the man who is actually in the arena; whose face is marred by the dust and sweat and blood; who strives valiantly; who errs and comes short again and again; who knows the great enthusiasms, the great devotions and spends himself in a worthy cause; who at the best, knows in the end the triumph of high achievement, and who, at worst, if he fails, at least fails while daring greatly; so that his place shall never be with those cold and timid souls who know neither victory or defeat.”

President Theodore Roosevelt, A.D. 1910

Acknowledgments

I owe a special debt of gratitude to my advisor, Major Blue, who provided the opportunity to work on this thesis. His patience and guidance during the entire process demonstrated his ability as a teacher and professionalism as a military officer. I especially would like to thank Major Blue for his help in designing the simulation model. I owe an equally deep debt of gratitude to Captain Scudder, AFIT's Vice Commandant, who gave me the opportunity to finish my Master's degree and constantly instilled confidence in me through many challenging days. I appreciate Commander Stevens being a true mentor and guiding me through the thesis process. His sound advice and listening ear were critical during difficult times. I would like to thank my friends Wes, Barth, Mark, and Ryan who were a constant encouragement along the way. I entered AFIT with a great group of Navy TPS Co-op students, and I wish them the best in the test world and beyond. To Mehdi and Tony, your friendship runs deep and I will never forget how you helped me in dark times. Many faculty members helped me through AFIT, and I wish to thank Dr. King, Dr. Cobb, Dr. Liebst, Dr. Jacques, and Major Branam for their support. My deepest thanks I reserve for my wife; God blessed me beyond measure with your love and you are a true help-mate. I end by acknowledging Jesus Christ, the author and perfecter of my faith. This time period was an analogy to me of a lifetime of working out my faith with fear and trembling; an imperfect man trusting God through the trials of life. Solo Deo Gloria!

Joshua D. Crouse

Table of Contents

	Page
ABSTRACT	IV
ACKNOWLEDGMENTS	VI
LIST OF FIGURES	X
LIST OF TABLES	X
LIST OF SYMBOLS	XI
I. INTRODUCTION	1
1.1 OVERVIEW	1
1.2 CURSOR-ON-TARGET DEFINITION.....	2
1.3 ALTERNATIVE DEPARTMENT OF DEFENSE DEFINITION OF CURSOR-ON-TARGET.....	2
1.4 PROBLEM STATEMENT	3
1.5 PROPOSED SOLUTION.....	3
1.6 THESIS OBJECTIVES	3
1.7 BACKGROUND ON DEPARTMENT OF DEFENSE UAS.....	4
1.7.1 Roadmap for Department of Defense Unmanned Aircraft Systems	4
1.7.2 Funding for Department of Defense Unmanned Aircraft Systems	5
1.7.3 Why Unmanned Aircraft Systems?.....	5
1.7.4 United States Navy Broad Area Maritime Surveillance (BAMS) Concept.....	6
1.7.4.1 Details of BAMS Unmanned Aircraft Systems and the P-8A	8
1.7.4.2 BAMS Micro-UA Proposal.....	9
1.7.4.3 Funding for BAMS and the P-8A.....	10
1.7.4.4 P-8A Command and Control of BAMS	10
1.8 POTENTIAL REAL WORLD SCENARIO.....	11
1.9 THESIS OUTLINE	13
II. LITERATURE REVIEW	14
2.1 INTERFACE OPTIONS FOR UAS CONTROL	14
2.1.1 Target Designation by Speech, Joystick, and Touch Control: Format Design Implications (Curry, 1985)	14
2.1.2 An Examination of Cursor Control Techniques to Designate Targets on a Cockpit Map Display (Liggett, 1995)	15
2.1.3 Helmet Mounted Displays for Unmanned Aerial Vehicle Control, (Morphew, 2004).....	16
2.1.4 Evaluation of a Touch Screen-Based Operator Control Interface for Training and Remote Operation of a Simulated Micro-Uninhabited Aerial Vehicle (Cook, 2006)	17
2.1.5 Summary of Interface Applications to Cursor-on-Target	18
2.2 VISION BASED NAVIGATION.....	18
2.2.1 Closely Supervised Reactive Control of an Uninhabited Aerial Vehicle, (Glassco, 1999).....	19
2.2.2 Study of Visual Cues for Unmanned Aerial Vehicle Waypoint Allocation, (Trinh, 1999)	20
2.2.3 A New Scheme of Vision Based Navigation for Flying Vehicles - Concept Study and Experiment Evaluation (Jianchao, 2002)	20
2.2.4 Vision-Based Road-Following Using a Small Autonomous Aircraft (Frew, 2004)	21
2.2.5 Vision-Only Aircraft Flight Control Methods and Test Results (Proctor, 2004).....	21
2.2.6 Augmenting UAV Autonomy – Vision-Based Navigation and Target Tracking for Unmanned Aerial Vehicles (Lundington, 2006).....	22
2.2.7 Fusion of Imaging and Inertial Sensors for Navigation (Veth, 2006).....	22

	Page
2.2.8 <i>White Paper: Analysis of Risk Associated with Integrating Sensors on MAVs (Garrett, 2007)</i>	23
2.2.9 <i>Summary of Vision Based Applications to Cursor-on-Target</i>	24
III. PROBLEM SETUP AND DEFINITIONS	26
3.1 ASSUMPTIONS FOR COT DEVELOPMENT	26
3.2 SENSOR INFORMATION	27
3.3 ELECTRO-OPTICAL TARGET ACQUISITION PROCESS	29
3.4 VEHICLE EQUATIONS-OF-MOTION	31
3.5 CHAPTER SUMMARY	33
IV. UAS SIMULATION FOR CURSOR-ON-TARGET CONTROL DEVELOPMENT	34
4.1 SIMULATION SOFTWARE	34
4.1.1 <i>Simulink</i>	34
4.1.2 <i>Aviator Visual Design Simulator (AVDS)</i>	34
4.2 UAS SIMULATION	35
4.2.1 <i>Overview</i>	35
4.2.2 <i>Cursor-on-Target Control System</i>	36
4.2.3 <i>Mouse Position from Graphical-User-Interface</i>	38
4.2.4 <i>Unmanned Aircraft Model</i>	39
4.2.5 <i>Camera Model</i>	40
4.2.6 <i>Target Model</i>	41
4.3 CHAPTER SUMMARY	42
V. PROPOSED UAS OPERATOR RATING SCALE	43
5.1 COOPER-HARPER SCALE BACKGROUND	43
5.2 LACK OF CURRENT UA RATING SCALES	43
5.3 UAS RATING SCALE	45
VI. DEMONSTRATION AND TEST RESULTS	47
6.1 DEMONSTRATION	47
6.2 TEST PLAN	48
6.2.1 <i>Test Plan Scenarios</i>	50
VII. RECOMMENDATIONS AND CONCLUSIONS	53
7.1 RECOMMENDATIONS FOR FUTURE WORK	53
7.2 ADDITIONAL COMMENTS	54
7.3 CONCLUSIONS	54
APPENDIX A : RATING SCALES	55
COOPER HARPER RATING SCALE	55
PILOT INDUCED OSCILLATION RATING SCALE	56
APPENDIX B: SIMULINK DIAGRAMS	57
B.1 TOP TIER VIEW	57
B.1.1 UA INITIAL CONDITIONS	57
B.1.2 UNMANNED AIRCRAFT SYSTEM	58
B.1.2.1 <i>Autopilot Modem from Ground Station</i>	58
B.1.2.2 <i>UA Model</i>	59

	Page
<i>B.1.2.3 Camera Model</i>	61
<i>B.1.2.4 COT Control System Embedded MATLAB Function</i>	63
<i>B.1.2.5 Ground Station Modem to Autopilot</i>	64
B.1.3 TARGET MODEL	64
BIBLIOGRAPHY	65

List of Figures

	Page
FIGURE 1. NAVY BAMS UAS PROGRAM (U.S. NAVY)	6
FIGURE 2. THE P-3C AND P-8A ; THE PAST, PRESENT, AND FUTURE OF MARITIME PATROL (U.S. NAVY).....	7
FIGURE 3. BAMS UAS - GLOBAL HAWK VARIANT IS ONE POSSIBILITY (U.S. AIR FORCE)	8
FIGURE 4. COYOTE SONOCHUTE-LAUNCHED EXPENDABLE UA (S-LUA) (ADVANCED CERAMICS RESEARCH)	9
FIGURE 5. MAP OF TAIWAN STRAIT; ASSETS AVAILABLE FOR U.S. RESPONSE TO THE POTENTIAL SCENARIO	12
FIGURE 6. SIDE-VERTICAL VIEW OF UA SENSOR BEAM (RUFA, 2007)	27
FIGURE 7. TOP-DOWN VIEW PRODUCING TRAPEZOIDAL FOOTPRINT OF UA SENSOR BEAM (RUFA, 2007)	28
FIGURE 8. GRAPHICAL USER INTERFACE DISPLAY WITH TRAPEZOIDAL LINES TRANSFORMED TO STRAIGHT LINES	28
FIGURE 9. FRONTAL VIEW OF UA SENSOR BEAM (RUFA, 2007)	28
FIGURE 10. ELEMENTS OF TARGET ACQUISITION PROCESS (MINOR, 2002).....	30
FIGURE 11. AVDS DISPLAY SHOWING SENSOR VIEW	35
FIGURE 12. COT CONCEPT WITH REALISTIC SUBSYSTEM DIVISIONS IN SIMULINK.....	36
FIGURE 13. COT FOLLOWING THE TARGET DURING A BANKED TURN	39
FIGURE 14. UA MODEL IN SIMULINK	40
FIGURE 15. TARGET MODEL IN SIMULINK	41
FIGURE 16. HANDLING QUALITIES DURING TRACKING DIAGRAM (LIEBST, 2006).....	45
FIGURE 17. PROPOSED UAS OPERATOR RATING SCALE	46
FIGURE 18. DEMONSTRATION OF COT WITH TARGET MODEL IN VIEW	47
FIGURE 19. OPERATOR RATING RESULTS FOR VARIOUS SCENARIOS.....	51
FIGURE 20. OPERATOR RATING RESULTS FOR VARYING HEADING AND AIRSPEED SCENARIOS	52

List of Tables

TABLE 1. UA OPERATIONS STANDARDS (UNITED STATES, 2005)	11
TABLE 2. SCENARIOS FLOWN TO EVALUATE COT	50

List of Symbols

Acronyms

- ASW – Anti-Submarine Warfare
- AVDS – Aviator Visual Design Simulator
- BAMS – Broad Area Maritime Surveillance
- CoT – Cursor on Target (old DoD definition)
- COT – Cursor-on-Target (current research definition)
- DDD – Dull, Dirty, Dangerous
- DoD – Department of Defense
- EO – Electro-Optical
- FOV – Field of View
- GPS – Global Positioning System
- GUI – Graphical User Interface
- HFOV – Horizontal Field of View
- HMD – Helmet Mounted Display
- INS – Inertial Navigation System
- IR – Infrared
- ISR – Intelligence, Surveillance, and Reconnaissance
- MAV – Micro Air Vehicle
- NIIRS – National Imagery Interpretability Rating Scale
- PRC – People’s Republic of China
- R.O.C. – Republic of China
- S-LUA – Sonochute-Launched expendable Unmanned Aircraft
- UA – Unmanned Aircraft
- UAS – Unmanned Aircraft System
- VFOV – Vertical Field of View

DEVELOPMENT OF CURSOR-ON-TARGET CONTROL FOR SEMI-AUTONOMOUS UNMANNED AIRCRAFT SYSTEMS

I. Introduction

1.1 Overview

The method to control Unmanned Aircraft (UA) varies greatly from remotely piloted to fully autonomous. Remotely piloted control requires full human involvement with the operator controlling all actions. Fully autonomous control does not require any human involvement and the flight path typically relies on waypoints for the vehicle to fly along. A necessary blend in many applications is semi-autonomous control, in which the ground operator can decide at which point to enter the control loop and only gives high level commands. The ground operator closes the control loop by observing vehicle flight parameters (Breneman, 1992).

The majority of military UA carry optical sensor equipment and relay images from those sensors back to a ground station. These images provide a picture of the operational environment and enable the operator to make decisions. This source of information is a passive source of information, and would not readily alert targets that they are being tracked. In missions that involve tracking moving targets, such as tanks on land or ships at sea, visual tracking is practical because continual geographical coordinates are not required for the target.

1.2 Cursor-on-Target Definition

The concept of Cursor-on-Target (COT) describes an alternative way for an operator to control a semi-autonomous UA. The Cursor-on-Target controller would allow the operator to place a cursor over the target of interest on data linked video from the UA and therefore direct the UA to track the target while at the same time collecting information. Depending on where the cursor is placed, the UA would steer toward the target and adjust its speed to direct the target to the middle of the display.

1.3 Alternative Department of Defense Definition of Cursor-on-Target

The Department of Defense (DoD) has previously defined the term “Cursor on Target (CoT)” and therefore their definition will briefly be explained to avoid confusion from the use of the definition in this research paper. In April 2002, Air Force Chief of Staff General Jumper stated his vision that “the sum of all wisdom is a cursor over the target.” This led to a software development by federally funded MITRE Corporation for CoT (Byrne, 2005). CoT allows different communities in the various Services the ability to share vital information near real-time. CoT leverages the widespread XML (eXtensible Markup Language) and defines a common extensible message format for communicating key targeting information (what, when, where). The goal is for an operator to reference the operational picture display, put his cursor over the target in question and upon clicking on the target receive tasking orders and data about the target from multiple sources. The U.S. Joint Forces Command conducted an experiment incorporating CoT with UAS. CoT allowed commanders in the field to obtain information from various UA and even allowed remote control of sensor video

(Roosevelt, 2005). Without the program details being published, it is hard to determine the level that MITRE's CoT technology will enable control of UA (Miller, 2004).

1.4 Problem Statement

Although autonomous UA control during most phases of flight reduces operator workload, real-time information exchange often requires an operator to relay decision changes to the UA. The goal of this research is to develop and evaluate a Cursor-on-Target control system that enables an operator to track moving targets with minimal workload even during high task phases of flight.

1.5 Proposed Solution

This research will develop a control interface that allows the operator to control a UA by simply positioning a cursor on display. The controller which connects the camera video to the aircraft equations of motion will first be modeled in Simulink (The MathWorks, 2004). This combination will then be integrated into the Aviator Visual Design Simulator (AVDS) (Rasmussen, 2005). When desired, the operator will then take over Cursor-on-Target control and guide the aircraft.

1.6 Thesis Objectives

The objective of the proposed research is three-fold. The first objective is to develop a COT controller. This objective will enable an operator without military pilot training the ability to control a UA. The second objective is to demonstrate the feasibility of COT control by testing various real-world scenarios. This objective will be tested by

taking untrained operators and allowing them to try out the developed controller in an operator-in-the-loop simulation. The third objective will be to evaluate the COT controller through measures of performance based upon a Cooper-Harper type rating scale.

1.7 Background on Department of Defense UAS

1.7.1 Roadmap for Department of Defense Unmanned Aircraft Systems

The Department of Defense's "Unmanned Aircraft Systems Roadmap, 2005-2030" is a foundational document for any discussion concerning United States military UA. In the roadmap, the stated goal is "to guide the Department toward a logical, systematic migration of Unmanned Aircraft Systems (UAS) mission capabilities focused on the most urgent warfighter needs (United States, 2005)." The twenty-five year span allows identification of future timeframes when technology should become available and covers a typical generation of aircraft from laboratory research to fielded system.

Although intended to be strong guidance, each Service is ultimately responsible for prioritizing requirements and authorizing specific UAS. In March 2007, Air Force Chief of Staff General Moseley proposed that the Air Force should gain oversight for developing UA that operate above 3,500 feet in order to avoid duplication of service acquisition efforts, decrease cost in developing new technologies, and standardize operations and training (Rolfsen, 2007; Allard, 2007). A recent House Armed Services subcommittee hearing on the proposal received opposition from Army, Navy, and Marine leadership. This opposition was due to an anticipated lack of connection by the Air Force with specific Service needs should they become the sole Service responsible for higher

altitude UA. This discussion is not finalized and the separate services are now required to submit in writing why they disagree with the Air Force proposal (Wehrman, 2007).

1.7.2 Funding for Department of Defense Unmanned Aircraft Systems

The clearest demonstration of DoD support for UAS can be seen by observing funding profiles. Between 1990 and 1999, over \$3 billion was invested in UAS development, procurement, and operations. This amount grew to over \$4 billion between 2000 and 2004, with fiscal year 2003 being the first billion-dollar year in history. Between 2005 and 2006 another \$4 billion was spent, with fiscal year 2005 being the first \$2 billion-year. The next four years, 2007-2011, will again see increased spending to exceed \$13 billion (United States, 2005). Such funding profiles show resolve to see the roadmap goals become a reality.

1.7.3 Why Unmanned Aircraft Systems?

Since so many resources are being dedicated toward UAS development, it is wise to ask what advantage a UA has over manned aircraft. The latest Roadmap focuses on UAS in order to emphasize that UA are only one component of a system that includes the operator, ground station, and satellites if necessary. A UA, by definition is “a powered, aerial vehicle that does not carry a human operator, uses aerodynamic forces to provide vehicle lift, can fly autonomously or be piloted remotely, can be expendable or recoverable, and can carry a lethal or non-lethal payload. Ballistic or semi-ballistic vehicles, cruise missiles, and artillery projectiles are not considered unmanned aerial vehicles (United States, 2005).” The catch-phrase “dull, dirty, or dangerous” (DDD) describes those missions in which UA make a strong case for replacing manned aircraft.

Dull missions such as long-range bombing or Intelligence, Surveillance and Reconnaissance (ISR) flights require long periods of alertness. A rotating crew on the ground can match the sustained in-flight time of a UA. For dirty missions such as flights in nuclear, chemical, biological, and radiological environments, as well as dangerous missions such as reconnaissance and suppression of enemy air defenses (SEAD) flights, the removal of human casualties if the mission is lost, and higher confidence in mission success are strong motivators for UA (United States, 2005).

1.7.4 United States Navy Broad Area Maritime Surveillance (BAMS)

Concept

Since all manned flights can in some way be categorized as DDD, one must understand that the Roadmap calls for a gradual transition from manned to unmanned flight in areas that overlap capabilities or require new technology. A key question to be asked prior to UAS development is what requirements for military capabilities could potentially be filled by UAS. This requires forethought and preparation rather than creating a UA for every situation. The Navy has answered this question with a concept termed Broad Area Maritime Surveillance (BAMS) (see Figure 1).



Figure 1. Navy BAMS UAS Program (U.S. Navy)

BAMS is the Navy's unique venture to blend the capabilities of UA and manned aircraft. The concept resulted from the immediate need to replace the entire P-3C Orion fleet. The P-3C aircraft is the Navy's workhorse to conduct anti-submarine warfare (ASW), anti-surface warfare, and overland ISR missions (see Figure 2). The P-3C is an aging airframe and requires a replacement by 2013 as the fleet has already dwindled from greater than 300 aircraft to approximately 150 aircraft. Many of the P-3C missions, especially ASW, require a manned aircrew. Regardless of this fact, healthy debate over UAS's role in the future occurred when the Navy conducted an Analysis of Alternatives in 2000. The analysis "identified manned aircraft as an essential element of the suite of systems that will satisfy" the needed missions for the next generation of aircraft (United States, 2003). Thus, a new Multi-Mission Aircraft concept was created and is now identified as the P-8A, a militarized Boeing 737-800 (see Figure 2).



Figure 2. The P-3C and P-8A ; The past, present, and future of Maritime Patrol (U.S. Navy)

1.7.4.1 Details of BAMS Unmanned Aircraft Systems and the P-8A

BAMS UAS will operate in conjunction with the P-8A. Starting in 2013, 108 P-8A aircraft along with 110 BAMS UAS will gradually replace the currently operating P-3C Orion (United States, 2006). All current missions will continue to be performed by the manned P-8A platform. BAMS UAS will primarily be developed to provide persistent, worldwide maritime ISR capability. The UAS will be unarmed, possess high endurance, and will operate from land-based sites worldwide (see Figure 3). Eventually each BAMS UAS site will support five to six vehicles that will be capable of 24 hour, 7 days a week coverage to on-station ranges of 2,000 nautical miles (Pike, 2006). In addition to contributing a reliable U.S. operational picture of the battlespace, BAMS UAS will provide communication relay capability in a “low hanging satellite” role (United States 2005). Many options are currently being considered as the BAMS UAS and the final decision is expected in July 2007.



Figure 3. BAMS UAS - Global Hawk variant is one possibility (U.S. Air Force)

1.7.4.2 BAMS Micro-UA Proposal

In addition to BAMS UAS, Sonochute-Launched expendable UA (S-LUA) are also being developed to augment the P-8A. The purpose of such S-LUA is twofold; to provide standoff ISR capability, and reduce engine wear and fuel burned. One prototype is the Coyote designed by Advanced Ceramics Research in 2004 (see Figure 4). The Coyote had a Level IV demonstration in July 2006, which enabled S-LUA and sensor payload command and control (see Table 1). At a unit cost of less than \$10,000, it could realistically cost less than a P-3C or P-8A descending from altitude, cruising at sea level, and then returning to altitude. It will be launched from sonobuoy tubes, weighs 14 lbs, has a range of 20 nm and endurance of 1.5 hours on electric power (Peck, 2006). The Coyote is programmable while still in the launch mode, and at release, goes into a glide mode for a fast descent at 100 knots. Once on station, it transitions to a cruise speed of approximately 75 knots and follows GPS-based waypoints in automatic mode. It can also be controlled by a line-of-sight datalink. The Coyote can carry either electro-optical (EO) or infrared (IR) cameras (Sherman, 2006). Initial production included a fixed camera and research is being conducted to explore an inexpensive gimbaled camera (Goodall, 2005).



Figure 4. Coyote Sonochute-Launched expendable UA (S-LUA) (Advanced Ceramics Research)

1.7.4.3 Funding for BAMS and the P-8A

Current budgetary constraints do not allow for enough P-8A aircraft to be procured in order to completely replace the P-3C fleet and fulfill all needed missions. Each of the projected 108 P-8As, based on Boeing's 737-800, cost \$172 million for a total cost of \$18.5 billion. This financial restriction became a golden opportunity for the Navy to adapt UAS to cover many of the DDD roles that the P-3C had performed. The BAMS UAS has been given a budget of over \$1.3 billion from FY05-FY11 with the type of platform to be decided in the summer of 2007 (United States, 2005). The Coyote is another relatively inexpensive development with less than \$800,000 devoted to testing as of January 2006 (Peck, 2006). Once the programs combine in the operational world, the unparalleled worldwide capabilities provided will prove a valuable return on investment.

1.7.4.4 P-8A Command and Control of BAMS

Once on-station, the P-8A will be able to correlate data from BAMS UAS in order to achieve information superiority. The initial production P-8A will be capable of Level II Command and Control (see Table 1), which will allow near real-time receipt of UA sensor data via direct link. Later production blocks of P-8A will be capable of Level IV Command and Control, which will enable UA and sensor payload command and control (United States, 2006). The ability to connect the P-8A with BAMS UA or S-LUA will greatly magnify the reach of fleet commanders as demonstrated in the following scenario.

Table 1. UA Operations Standards (United States, 2005)

Level 1	Indirect receipt/transmission of UA related payload data
Level 2	Direct receipt of ISR/other data where “direct” covers reception of the UA payload data by the Unmanned Control Station when it has direct communication with the UA
Level 3	Control and monitoring of the UA payload in addition to direct receipt of ISR/other data
Level 4	Control and monitoring of the UA, less launch and recovery
Level 5	Control and monitoring of the UA (Level 4), plus launch and recovery functions

1.8 Potential Real World Scenario

Based on recent intelligence and public sources (Halloran, 2007), the following motivational scenario is a real possibility and one that clearly shows the role that UA and S-LUA could play in increasing the P-8A’s capabilities.

September 2015:

The People’s Republic of China (PRC) has launched a massive military exercise in the Taiwan Straits in a deliberate attempt to put intense political pressure on the Republic of China (R.O.C.) (see Figure 5). PRC has put to sea fifty-five naval vessels, of which ten PRC diesel submarines are unlocated. This naval task force has cut off all commercial traffic in the Straits and to Taiwan. In addition, PRC has launched multiple missile tests in the area, with one missile flying over the island of Taiwan. These actions have threatened the stability of the entire region, and intense pressure is being felt by the United States to intervene on R.O.C’s behalf.



Figure 5. Map of Taiwan Strait; Assets available for U.S. response to the potential scenario

Due to political constraints, no U.S. naval surface vessels are sent into the volatile Straits. However, both P-8A and BAMS UAS assets are stationed in Japan, and provide 24 hour, 7 days a week coverage as the events unfold. The P-8A aircraft provides an armament platform to demonstrate the strength of the U.S. but remains outside of the weapon ranges of PRC surface vessels. The P-8A platform can task either BAMS UA or S-LUA to fly into the Straits and maintain ISR coverage of the unfolding events. In the event the UA is lost, there would be no loss to human life, while at the same time the U.S. can claim a direct attack against sovereign U.S. property.

To complicate matters, all satellite coverage and communications have been lost for unknown reasons, including Global Positioning Satellites. The BAMS UA is able to proceed on-station via INS. Once on-station, Command and Control by P-8A is necessary to acquire and track the constantly moving naval vessels. An operator onboard P-8A is able to direct either BAMS UA or S-LUA below an 8,000 to 12,000 foot cloud deck to allow EO and IR sensors to acquire the needed type and name of each individual surface vessel by COT control. This information provides a complete surface picture of PRC capabilities to fleet commanders.

1.9 Thesis Outline

In this Chapter, an introduction of the concept of COT was given, to include the DoD's and specifically the Navy's future roadmap for UA. Chapter II reviews published research applicable to COT, specifically focusing on interface options for UAS control and vision based navigation. Chapter III discusses the assumptions for COT design, sensor information, electro-optic target acquisition process, and vehicle equations of motion. Chapter IV describes in detail the development of COT and provides diagrams of the simulation for visual reference. Chapter V proposes a UAS operator rating scale. Chapter VI lays out a test plan with scenarios, describes the measures of performance used to evaluate the COT performance, and discusses the test results. Chapter VII summarizes completed research and lists recommendations for improvement for follow-on research.

II. Literature Review

2.1 Interface Options for UAS Control

Human operators will always remain in the control loop of UA control to some degree due to the dynamic nature of flight and the situations in which UA will be used. However, the way humans will interface with UA may change dramatically over the years. The Roadmap states that for “those UA remaining under human control, the controller will eventually be linked to his remote charge through his own neuromuscular system (United States, 2005).” Electrical signals sent to muscles will translate into instantaneous control inputs to UA. Until the day technology advances to that point, the available technologies of touch control screens, voice control, cursor control, and helmet mounted displays provide a wide variety of options for interfacing with UAS. A review of research conducted on these options provides a good point of reference for why COT is a viable option for the proposed research.

2.1.1 Target Designation by Speech, Joystick, and Touch Control: Format Design Implications (Curry, 1985)

In an investigation at Wright-Patterson Air Force Base in 1985, the Flight Dynamics Laboratory compared target designation by standard joysticks, touch sensitive overlays, and an unconstrained voice recognition system versus the traditional keying in of the geographical coordinates and elevation. In this experiment, pilots wore flight gear and equipment for use in a chemical, biological, and radiological environment. The study was clear in pointing out the advantages and disadvantages of the different methods. The

results showed that the touch-sensitive control mode was significantly faster than that of either the joystick or the voice recognition mode, while there was no significant difference between the latter two modes. Of subjective note, the joystick was found to be mentally difficult to operate due to the inability of subjects to manipulate the cursor using peripheral vision. The opinion of which mode should be implemented showed an even split between voice and touch control. However, all three modes were superior to that of keying in particular geographic coordinates for each point.

2.1.2 An Examination of Cursor Control Techniques to Designate Targets on a Cockpit Map Display (Liggett, 1995)

In another investigation conducted at Wright-Patterson Air Force Base Advanced Cockpit Branch in 1995, a touch control system, voice control system and traditional target designation control (TDC) on the throttle were compared. Pilots tested the performance of these controls in the designation of targets on displays. Results concluded that the touch control system always provided significantly faster designation times when compared to the TDC, and the TDC was significantly faster than the voice control. The intuitive nature of the touch control system contributed to this result. In particular, the touch control system was recommended for multiple moving targets on a two-dimensional, look-down view because it can be used quickly and accurately.

2.1.3 Helmet Mounted Displays for Unmanned Aerial Vehicle Control, (Morphew, 2004)

In a 2004 experiment at the Ames Research Center, Moffett Field, CA, the effect of a UA operator wearing a Helmet Mounted Display (HMD) versus using a conventional computer joystick to perform a sensor target search task was assessed. The experiment explored the costs and benefits associated with using HMDs for UA Ground Control Station operation. The objective performance measures included target detection accuracy and response. In addition, subjective measures included fatigue, situational awareness, and sickness. The operators used both HMD and a joystick to direct the UA's sensor to search for targets in a virtual world while the UA flew 70 knots at an altitude of 5,000 feet. The UA's sensor had a six degree field of view (FOV) while the HMD had a horizontal FOV of fifty degrees. This resulted in a magnification effect of approximately seven times. The sensor's slew rate of sixty degrees per second required a limiter to be installed on the HMD to better approximate the actual sensor behavior. The results showed no significant difference in operator ability to correctly classify targets. However, the conventional joystick cursor method resulted in better tracking accuracy and classification farther away from the target. On a negative note, the HMD resulted in significant simulator sickness including nausea, eye strain, and disorientation. The study concluded by stating that advanced technologies like HMD should only be implemented if they "demonstrate an improvement over the existing technology in the desired dimension (Morphew, 2004)."

2.1.4 Evaluation of a Touch Screen-Based Operator Control Interface for Training and Remote Operation of a Simulated Micro-Uninhabited Aerial Vehicle (Cook, 2006)

In 2004, the U.S. Army Research Institute evaluated a touch screen-based operator control for a backpackable micro air vehicle (MAV). The operator control unit developed by Northrop-Grumman took a unique approach to teleoperation. It allowed manual control by touching a spot on the sensor image itself and directed the vehicle relative to what is seen in the sensor image. The MAV was equipped with a forward-looking and downward-looking fixed camera and only one view was seen at a given time. Participants rated the operation as difficult, due to maneuvering based on a fixed camera and the complex rules that governed the translation of a single input into the MAV response. A human moving through space has several sources of information, and can make anticipatory movements toward the position they are approaching. In the video feed, this information is largely absent. The MAV tested was a vertical takeoff and landing vehicle. Touching the sensor image moved the MAV forward into the image. Each touch on the left or right side the sensor image rotated the MAV heading by an angle proportional to the distance from center. Touching below the center reduced the altitude and touching above the center maintained altitude. The distance and speed that the MAV moved was a function of its current altitude. In summary, one input had the capability of moving the MAV in three dimensions. This was too demanding for novice users, and the study concluded that it would be “better to translate a single touch to up/down and left/right (Cook, 2006).”

2.1.5 Summary of Interface Applications to Cursor-on-Target

Although technology is improving, cursors and more advanced touch screens have been a reliable interface choice for the past twenty years. This is especially true for multiple moving targets as noted by the Advanced Cockpit Branch. The U.S. Army Institute article is of particular interest because of the close similarity to the current research problem (Cook, 2006). The goal in that research was to enable an untrained aircraft operator to be able to control the UA with a touchscreen interface. The main difference between that research and the current problem was the cursor gave updated position coordinates for the UA to fly; the current research has the cursor actually controlling the flight path constantly. The main lesson to be learned from the Army research is to make the interface and cursor inputs very elementary to the operator and therefore provides motivation to approach the problem from a different perspective. In conclusion, this research will use mouse inputs due to the simplicity of the setup and the ease of transition between it and a touchscreen in future development.

2.2 Vision Based Navigation

Vision based navigation is a complex task which has not been fully mastered. The goal of vision based navigation is to replace human vision with computer vision which sufficiently performs all the required tasks. Human vision is an amazing combination of the eye and brain. The cornea and lens of the eye focuses an image of the outside world onto a light-sensitive membrane in the back of the eye, called the retina. The retina is actually part of the brain that is isolated to serve as a transducer for the conversion of patterns of light into neuronal signals (Lewis, 2000).

Although what is seen is a major influence on what the brain perceives, psychologists are also studying “unconscious inference,” which are assumptions the brain believes (Purves, 2007). This inference strongly influences what the brain believes about vision and can lead to visual allusions. This problem must be discussed as it is a critical topic when replacing pilots with UA. The replacement of human pilot vision with UA sensors greatly reduces the situational awareness of a ground operator yet makes economical sense and at times is operationally necessary. A review of research conducted on computer vision is necessary since all UA carry some form of sensor equipment.

2.2.1 Closely Supervised Reactive Control of an Uninhabited Aerial Vehicle, (Glassco, 1999)

At the Air Force Institute of Technology in 1999, Captain Glassco’s thesis proposed that a UA operator could exercise closely supervised reactive control by target selection from on-board camera video. The flight path of the UA was determined autonomously from camera gimbal angles. The UA, using an on-board computer, was given autonomous control to alter its flight path to fly towards a target and at a specified range, loiter over the target. The operator had two modes of operation, manual and advanced. In the manual mode, the camera operator manually tracked the target providing continuous updates to the camera angles. In the advanced mode with the use of INS or GPS, the aircraft could autonomously determine the camera angles from which to fly from a single locked position which would leave the operator free to look for other targets.

2.2.2 Study of Visual Cues for Unmanned Aerial Vehicle Waypoint

Allocation, (Trinh, 1999)

A 1999 study at the Massachusetts Institute of Technology focused on unmanned aerial vehicles with humans present in the outer supervisory control loop. Visual cues for an operator station were evaluated using a flight simulator with the goal of collecting one minute of video data of a specified target. The vehicle contained two fixed cameras, one front-facing and one side-facing. Each camera had a vertical FOV (VFOV) of sixty degrees and horizontal FOV (HFOV) of thirty-six degrees and each was tilted downward forty-five degrees. The simulation assumed a point mass model, constant altitude and velocity, and no winds. The user interface was a graphical display and mouse. The study concluded that the side-viewing camera was twenty-five percent more effective than the forward facing camera in minimizing total time required to accumulate one minute of time on target. However, the forward view was preferred for target locating by a two to one ratio.

2.2.3 A New Scheme of Vision Based Navigation for Flying Vehicles -

Concept Study and Experiment Evaluation (Jianchao, 2002)

In December 2002, the Signal Processing Laboratory in Singapore proposed a vision based navigation scheme for long range navigation in which the main navigation tool was a camera, complimented by an altimeter. The fundamental idea was to infer inter-frame 3D incremental motion of the camera from an image displacement field embedded in two consecutive frames. The altimeter was an aid to the camera in order to avoid the issue of uncertainty in scaling factor, so that the metric structure of motion

could be recovered uniquely. The experiment was conducted on a helicopter with INS and GPS also installed to provide a baseline position measurement. The results with the camera and altimeter were far from the accuracy expected. However, when gyroscope data was added as an orientation sensor, the position error was greatly reduced from 286.65 meters to 4.9 meters.

2.2.4 Vision-Based Road-Following Using a Small Autonomous Aircraft (Frew, 2004)

In January, 2004, the Center for Collaborative Control of Unmanned Vehicles at the University of California–Berkeley designed a road-following vision-based control for a UA. The goal of the work was to enable the tracking of a roadway using only the natural features of the scene and no additional navigation sensors. The computer system would detect natural features of the scene and track the roadway in order to determine relative yaw and lateral displacement between the aircraft and the road. The problem required detection of the road within an image and calculation of the distance of the aircraft away from it. The flight of the aircraft was controlled in order to follow the road and bring the cross-track error to zero. Hardware-in-the-loop demonstrations and actual flight tests verified the performance of the system and offered encouraging results.

2.2.5 Vision-Only Aircraft Flight Control Methods and Test Results (Proctor, 2004)

In August, 2004, a team at Georgia Tech successfully developed a glider which was capable of flying from a starting point to an ending location using only a single vision sensor. This research differed from previous work in that it utilized only vision for

determining the position, velocity, attitude, desired flight path, and required control commands in an outdoor environment. The research was focused on the idea that if a human pilot can visually acquire a specified destination and fly to it, a computer should be able to do the same. The system has the advantage of having a simple hardware configuration making it a low cost solution for an autopilot and an attractive choice for a completely isolated back-up system.

2.2.6 Augmenting UAV Autonomy – Vision-Based Navigation and Target Tracking for Unmanned Aerial Vehicles (Lundington, 2006)

In September, 2006, another team at Georgia Tech demonstrated a vision-based navigation system on an unmanned research helicopter. The key idea was to incorporate visual data as an input to an automatic control system. The visual control system would aid in the formation of a navigation solution, identify regions of interest in an urban environment, and automatically track a mobile ground target. The target was known and assumed to be within view of the camera. The navigation solution used vision and inertial measurements within an extended Kalman filter to estimate the vehicle state. An automated search system allowed the UA to search an urban region for a particular building and then identify the openings to the building. The tracking of a maneuvering ground target relied upon an algorithm integrated with the camera controller which generated a waypoint guidance.

2.2.7 Fusion of Imaging and Inertial Sensors for Navigation (Veth, 2006)

At the Air Force Institute of Technology in 2007, Major Veth presented an approach for fusing optical and inertial sensors for robust, self-contained, passive, and

autonomous navigation. The motivation behind the research was the observation of navigation capabilities in animals. Veth developed a practical model of sensors and presented a transformation technique to detect features within an image. Coupling images and inertial sensors aids the statistical feature matching function which in turn is used to estimate navigation trajectory using an extended Kalman filter. An image-aided inertial navigation algorithm was tested using a combination of simulation and ground tests. Conclusions pointed out limitations of the Kalman filter, however the experimental results “demonstrate a navigation performance improvement of at least two orders of magnitude over the respective inertial-only solutions (Veth, 2006).”

2.2.8 White Paper: Analysis of Risk Associated with Integrating Sensors on MAVs (Garrett, 2007)

At the Air Force Institute of Technology in 2007, Captain Knowlan and Major Phillips developed a risk calculation matrix to determine whether engineers can design a basic MAV which is effective in the operational context. The setup consisted of four video cameras; two were mounted boresight on the front and two were depressed thirty degrees from the horizon on the right side. Each position included a thirty and sixty degree FOV camera. The research analyzed at what range the user would be able to detect (properly name) and identify (name by type or class based on configuration) a target while flying at 100 m and 50 m and how much time the user would have to react. The definition of detect and identify originated from the National Imagery Interpretability Rating Scale (NIIRS). The maximum range a target could be detected or identified was

calculated. A simulation in MATLAB provided a visual representation to link the calculations to the NIIRS scale.

Operational scenarios were created to evaluate the MAV in flight. At 100 m in both FOV, the front camera was unable to identify but could detect the target. At 50 m in both FOV, the front camera was able to briefly identify for a distance and then detect the target for the remaining distance. For the side camera at 100 m, the thirty degree FOV camera could also partially identify and detect the target, but the sixty degree FOV camera could only detect the target. At 50 m, the side sixty degree FOV camera could also identify for a portion of the time, and detect the rest of the distance. The thirty degree FOV camera at 50 m was able to identify for the entire range. Having the side cameras tilted proved a clear advantage in acquiring the target. Also noteworthy was the fact that the time on target could be increased by entering a controlled turn with the side camera on target. Conclusions stated that increasing the tilt of the front cameras to 10-15 degrees reduced the required distance between the MAV and target and increased the ability to identify the target.

2.2.9 Summary of Vision Based Applications to Cursor-on-Target

Although vision navigation may seem like a simple task, recent research confirms it is still a topic to be explored. The ability to track a target without the need of GPS and INS is an attractive goal, not only in cost savings, but in reduced weight requirements and dependency on communication and navigation satellites. UA dependant on vision guidance alone have shown practical benefits to the warfighter on the ground in such systems as the Marine's RQ-2B Pioneer and the Army's RQ-5A Hunter by giving the

ability to view near real-time video (United States, 2005). Vision guidance is worth pursuing in even greater applications.

The technology is currently available to incorporate vision feedback into the logic of onboard automatic control. However, the challenge facing the military will be to tailor this technology to the needs of the specific Services. One UA cannot perform all missions because of various sensor capabilities and the varying requirements of military missions. This research will focus on missions that require an operator in the control loop at certain times because even those missions labeled “dull” can at times require the element of human judgment. The goal will be to incorporate the lessons learned from previous research to develop a simple way for operators to control UA using vision feedback to the ground control station.

III. Problem Setup and Definitions

This chapter explains the basic building blocks necessary to develop COT.

3.1 Assumptions for COT Development

Before beginning the task of developing a new controller, many assumptions must be made to simplify the process. The following assumptions were made for this research:

1. The UA is modeled as a point mass.
2. Flight is at a constant altitude.
3. The UA has adequately designed inner control loops that can hold a constant altitude and provide a commanded turn rate and airspeed acceleration (within the limits of the UA).
4. The UA has an electro-optic camera with a fixed angle and geometry.
5. The target's motion is within the UA's flight envelope (i.e. possible to track the target).
6. Wind speed is negligible.
7. A human controller is required to be a part of the control loop at some point in order to accomplish the UA's mission.

These assumptions provide a simple, yet adequate model to develop and test the feasibility of COT. Assumption seven is the driving motivation behind COT controller.

3.2 Sensor Information

Since UA depend on onboard sensors to provide situational awareness to the ground station operator, the sensor's information is an important element to understand. The sensor footprint is three-dimensional information being translated onto a two-dimensional screen. Since an in-depth study has not been conducted on electro-optical sensors for this research, only a basic explanation will be provided. The sensor footprint depends at a minimum on the sensor's specifications, mounting geometry, and vehicle's position, altitude, and attitude. Various recommendations on mounting geometry have been proposed by previous research, yet each UA will have different geometry based on mission needs and the airspeeds flown.

The geometry of the sensor footprint can be described using three different views: side-vertical view (see Figure 6), top-down view (see Figure 7), and frontal view (see Figure 9) as described in detail in (Rufa, 2007). For this research, only the vertical field of view (VFOV), as shown in Figure 6, and horizontal field of view, as shown in Figure 9, were used. Figure 7 shows the trapezoidal footprint that is translated to a rectangular display as depicted by Figure 8.

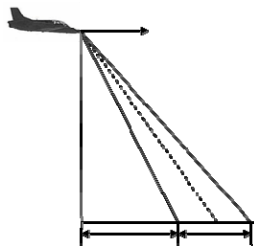

Figure 6. Side-Vertical view of UA sensor beam (Rufa, 2007)

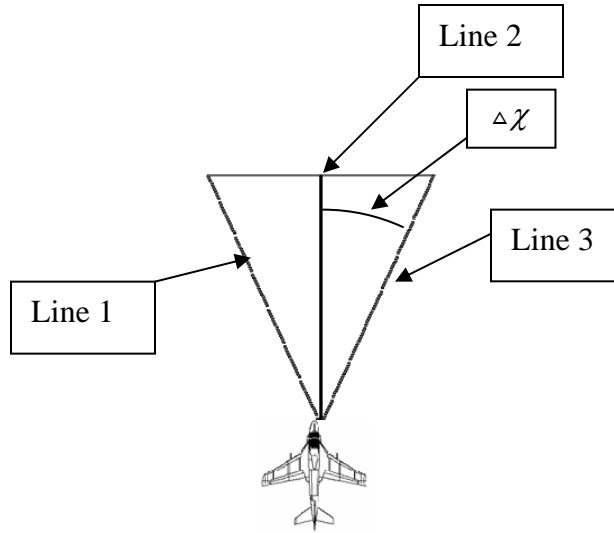

Figure 7. Top-down view producing trapezoidal footprint of UA sensor beam (Rufa, 2007)

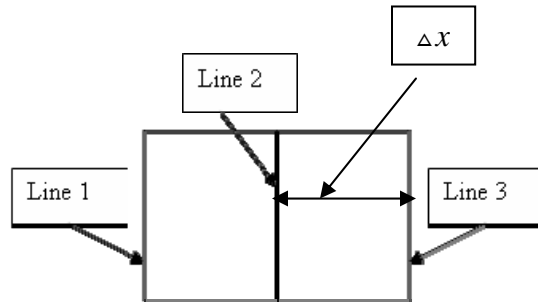

Figure 8. Graphical User Interface Display with trapezoidal lines transformed to straight lines

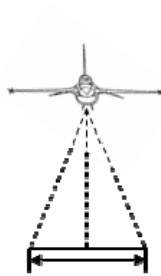

Figure 9. Frontal view of UA sensor beam (Rufa, 2007)

The sensor footprint can vary depending on the sensor's FOV. From high altitudes, the footprint will be more rectangular based upon a steep depression angle. At lower altitudes with shallower depression angles, the footprint has a trapezoidal shape yet it is displayed on a rectangular display. This can be visualized by imagining three separate lines, two at the edges of the display, and one down the middle. The outside lines are in reality the outside diagonal lines of the trapezoidal footprint, with the only true straight line being the middle line (see Figure 7). All information that a sensor collects along a line in a given direction is displayed in vertical straight lines on the display (see Figure 8).

The display of a trapezoidal footprint onto a rectangle display aids in the development of COT in the following way. The placement of a cursor on a display may correspond in distance from a few hundred yards to a few miles from the UA. For lateral control, this seemingly would pose a problem as placement of the cursor in the distance would turn a UA more than needed. But since all vertical lines are in reality diagonal lines of the trapezoidal footprint, the horizontal position of the cursor on the display is proportional to the angle between the UA's heading and the line-of-sight angle to the heading marked by the cursor (see Figures 7 and 8).

3.3 Electro-Optical Target Acquisition Process

An electro-optical (EO) system is one in which “optics is used to collect photons in the optical range of the electro-magnetic spectrum and convert them into electrons that can be processed as electronic signals for a variety of useful purposes (Minor, 2002).” Such purposes are determined by the recipient of the information, and the human

observer is still the principle recipient of modern EO systems. Thus, despite technological advances, the ground operator is the prime decision maker and target acquisition device for most UAS using EO imaging systems. It is the ground operator's ability to interpret and use the information being presented by the EO system which is the critical element in the performance of the overall system.

The electro-optical acquisition process is a complex series of events depending on the order of many real world variables. The key variables are target and background, the atmosphere, the electro-optical system, the display system, and human performance limitations (see Figure 10). These variables combine to form an overall probability of target detection, recognition, identification, and classification. Since the goal of the acquisition process is to produce a system that meets operational requirements, one must understand the impact of the key variables in the overall testing process (Minor, 2002).

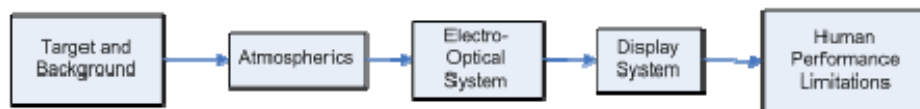

Figure 10. Elements of Target Acquisition Process (Minor, 2002)

Although the key variables can be broken into an even longer list, eventually one must weigh the relative importance of each in order to evaluate the overall system. EO system designers have concluded that the major inputs to the performance of EO sensors are dependant on both target and background and the human observer's performance. Since the target and background can be pre-planned to optimize acquiring the target, in the end it is the human observer's performance which is the limiting factor when

evaluating an EO system, and in particular, the UAS system. As a result, the interface which a ground operator uses is of critical importance when designing any UAS. Using the applicable “EO system flight tester fundamental disciplines” presented in Minor’s paper as a baseline, any UAS designer and flight tester should develop a solid grasp of the disciplines of optics, display systems, and human search processes/visual psychophysics (Minor, 2002).

3.4 Vehicle Equations-of-Motion

The equations of motion form the nucleus of the simulation, which is presented in the next chapter. Although relatively elementary, the point-mass UA model presented below was deemed sufficient for the research. Follow-on research will no doubt require a more in-depth analysis of the equations. To begin, differential equations were created as follows:

$$\frac{dN}{dT} = V_{TAS} \cos \chi \cos \gamma + W_N$$

$$\frac{dE}{dT} = V_{TAS} \sin \chi \cos \gamma + W_E$$

$$\frac{dh}{dt} = V_{TAS} \sin \gamma + W_z$$

$$\frac{dV_{TAS}}{dt} = u_1$$

$$\frac{d\chi}{dt} = u_2$$

$$\gamma = u_3$$

where V_{TAS} is true airspeed, χ is heading angle, γ is flight path angle, N is north position, E is east position, and h is altitude. u_1 , u_2 , and u_3 are the acceleration, turn-rate, and altitude commands from the COT controller to the UAS. The north and east components of the wind are obtained from:

$$W_N = W \cos \chi_w$$

$$W_E = W \sin \chi_w.$$

where W is wind speed and χ_w is wind heading angle.

The equation for the UAS's bank angle which drives the camera model in the simulation is:

$$\phi = \arctan \frac{V \frac{d\chi}{dt}}{g}.$$

However, given the assumptions of constant altitude and no wind, these simplified to:

$$\frac{dN}{dT} = V_{TAS} \cos \chi$$

$$\frac{dE}{dT} = V_{TAS} \sin \chi$$

$$\frac{dV_{TAS}}{dt} = u_1$$

$$\frac{d\chi}{dt} = u_2.$$

3.5 Chapter Summary

In summary, this chapter gave the background necessary for COT development. The assumptions used in the simulation were listed, sensor information and the electro-optic target acquisition process were explained, and the vehicle equations-of-motion were presented.

IV. UAS Simulation for Cursor-on-Target Control Development

4.1 Simulation Software

All research was performed in computer simulation using the MATLAB and Simulink program (The MathWorks, 2004), and the Aviator Visual Design Simulator (AVDS) (Rasmussen, 2005). The controller was first written in Simulink and then connected to AVDS to verify realistic responses, and additionally provides a real-time operator-in-the-loop capability.

4.1.1 Simulink

Simulink is a software package integrated into the computer program MATLAB. The purpose of Simulink is the modeling, simulating, and analyzing of both linear and non-linear dynamic systems. It is an interactive graphical environment with a customizable set of block libraries that allow models to be built as block diagrams. Complex designs can be broken into hierarchical top-down type organization. Simulink proved useful in this research because one could experimentally pose a problem, model it, and analyze the results with relative ease. Simulink also proved valuable due to its ability to interface with another simulation program, in particular AVDS, which provided real-time simulated visualization (i.e. simulated EO imagery).

4.1.2 Aviator Visual Design Simulator (AVDS)

The Aviator Visual Design Simulator (AVDS) is a highly detailed personal computer based flight simulator used in aerospace research and development. It was designed as a joint project between Artificial Horizons, Inc. and the United States Air

Force. AVDS allows researchers to visualize flight dynamics and flight controls and displaying aircraft orientation (See Figure 11). These features allowed realistic testing of the COT controller developed in Simulink. At the same time, it is simple to use because Simulink blocks are available to connect AVDS to MATLAB/Simulink (Rasmussen, 2005). An additional characteristic of interest for follow-on research is the ability for AVDS to interact with external hardware inputs and have hardware-in-the-loop simulator capability (Dugan, 2006).

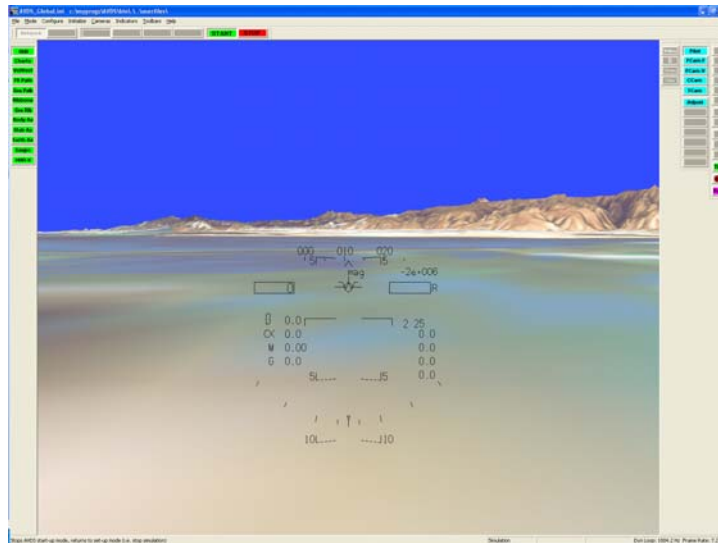

Figure 11. AVDS display showing sensor view

4.2 UAS Simulation

4.2.1 Overview

The purpose of the UAS simulation is to create a realistic model of the UAS so the COT concept can be developed in a realistic setting and transferred to real world application. The UAS simulation can be divided into four main subsystems: UA model, Camera Model, Mouse Position from Graphical User Interface (GUI), and the COT

Control System (see Figure 12). Additionally, to test the ability of the UAS to track a ground target using the COT controller, a target system was created. Simulink was the tool used to simulate the UA, the COT Control System, and the target. AVDS was the tool used to simulate the Camera Model and used to extract a Mouse Position from the GUI.

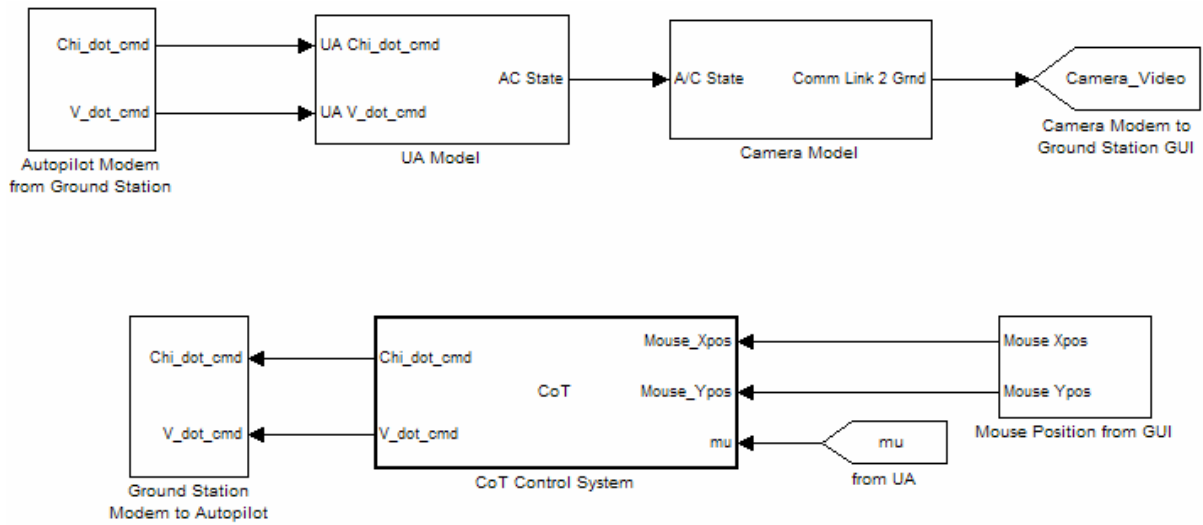

Figure 12. COT Concept with realistic subsystem divisions in Simulink

4.2.2 Cursor-on-Target Control System

The preliminary COT control system developed tracks the target by use of both Heading Control and Velocity Control. The COT controls heading by commanding the

UA's turn rate, $\frac{d\chi_{cmd}}{dt}$, and it controls velocity by commanding the UA's

acceleration, $\frac{dV_{cmd}}{dt}$. The required inputs for the COT controller are the X and Y position

of the mouse in the camera display GUI, the camera geometry, and the UA's bank angle.

The turn rate controller used for heading control is based on missile guidance, and a few options were considered (Garnell, 1980). First was pure pursuit control, where

$$\frac{d\chi_{cmd}}{dt} = K\Delta\chi \text{ and the commanded turn rate is proportional to the heading error, } \Delta\chi .$$

Second was proportional navigation, where $\frac{d\chi_{cmd}}{dt} = K\Delta\dot{\chi}$ and the commanded turn rate

is proportional to the rate of change of the heading error. Finally, the controller

implemented was a Dynamic Inversion Turn Rate Controller used in (Burns, 2007) where

$$\frac{d\chi_{cmd}}{dt} = K \tan(\Delta\chi) . \text{ This turn-rate controller has properties of both of the previous turn}$$

rate controllers. Its performance is similar to the proportional navigation controller, but

like the pure pursuit controller, the commanded turn rate is a function of the heading

error. As was explained in the Sensor Information section, the heading error, $\Delta\chi$, is

proportional to the x-position of the cursor from the center of the display, ΔX_{GUI} , which

is obtained from the GUI. This can be written as $\Delta\chi = \frac{HFOV}{2}\Delta X_{GUI}$, where $HFOV$ is

the horizontal field of view of the UA sensor.

For velocity control, an acceleration controller is used. Similar to the pure pursuit

type controller for turn rate, the acceleration controller is $\frac{dV_{CMD}}{dt} = K_v\Delta V$ and the

commanded acceleration is proportional to the velocity error, ΔV . By implementing the

controller using the camera GUI, let $\Delta V = K_y\Delta Y_{GUI}$, where ΔY_{GUI} is the y-position of the

cursor from the center of the display. Then, the final form of the equation is

$\frac{dV_{CMD}}{dt} = K_v K_y \Delta Y = \bar{K} \Delta Y_{GUI}$. In summary, this literally means that a turn rate will be

commanded if the ΔX_{GUI} is not zero and an acceleration will be commanded should

ΔY_{GUI} not equal zero.

4.2.3 Mouse Position from Graphical-User-Interface

The GUI visually displays the mouse position to the operator. Simulated camera video is generated by AVDS and displayed in the graphical-user-interface (GUI) along with the mouse position. The only AVDS signals forwarded to the Simulink COT Control System are mouse cursor positions. Since the equations for COT require as inputs the change in horizontal direction, ΔX_{GUI} , and vertical direction, ΔY_{GUI} , one must first map the camera display from -1 to +1 in both directions. With wings level, which is the simplest aircraft orientation, the inputs to the COT's turn rate and acceleration control

equations are $\Delta \chi = \frac{HFOV}{2} \Delta X_{GUI}$ and $\Delta V = \frac{VFOV}{2} \Delta Y_{GUI}$. The reference fields are

divided in half due to the center of the fields being the reference zero.

When the aircraft banks, ΔX_{GUI} and ΔY_{GUI} must be recalculated to include the bank angle φ and new terms ΔH_{GUI} and ΔV_{GUI} are created to include the position of the mouse along the horizon and vertically from the horizon (See Figure 13). The former

equations become $\Delta \chi = \frac{HFOV}{2} \Delta H_{GUI}$ and $\Delta V = \frac{VFOV}{2} \Delta V_{GUI}$

where $\Delta H_{GUI} = \Delta X_{GUI} \cos(\varphi) - \Delta Y_{GUI} \sin(\varphi)$

and $\Delta V_{GUI} = \Delta X_{GUI} \sin(\varphi) + \Delta Y_{GUI} \cos(\varphi)$.

This allows the turn rate and acceleration to remain constant if correctly tracking a target while the UA is banked even though the X and Y coordinates are not mapping to zero and zero respectively.

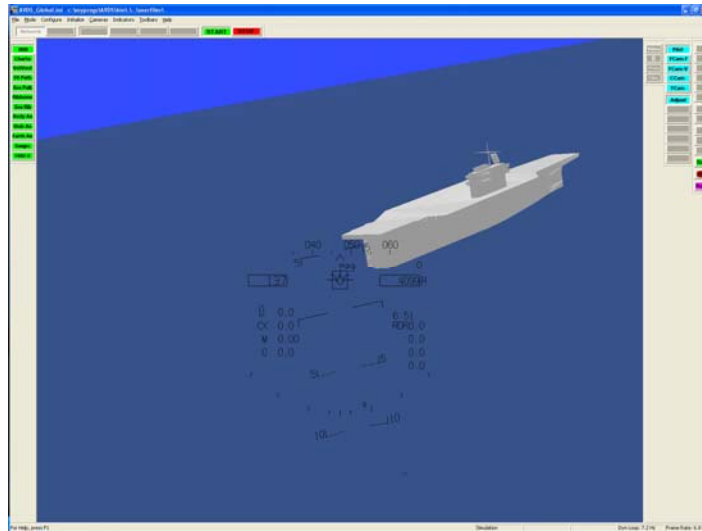

Figure 13. COT following the target during a banked turn

4.2.4 Unmanned Aircraft Model

The UA model contains equations which drive the camera model in the AVDS simulator. The equations explained in the Vehicle Equations-of-Motion Section form the backbone of the model and are included in an embedded MATLAB function. There are seven inputs to the model. The first three inputs, $u_1 \rightarrow u_3$ include the turn rate command and acceleration command outputs from the COT controller and the commanded altitude. Note that the turn rate command and acceleration command are passed through first-order low-pass filters to account for some actuator dynamics. The next four inputs, $x_1 \rightarrow x_4$ are actually states extracted from the model itself as a feedback loop once the equations have been integrated and include the aircraft velocity, heading, and north and east position.

The UA model outputs six variables that are sent to AVDS to drive the camera simulator. Two outputs, bank angle and altitude, are sent directly to AVDS (see Figure 14). The other four outputs, $\dot{x}_1 \rightarrow \dot{x}_4$, include acceleration, rate of heading change, and position rate of change in north and east directions. These outputs are fed through an integrator before flowing to AVDS and also being fed back as inputs.

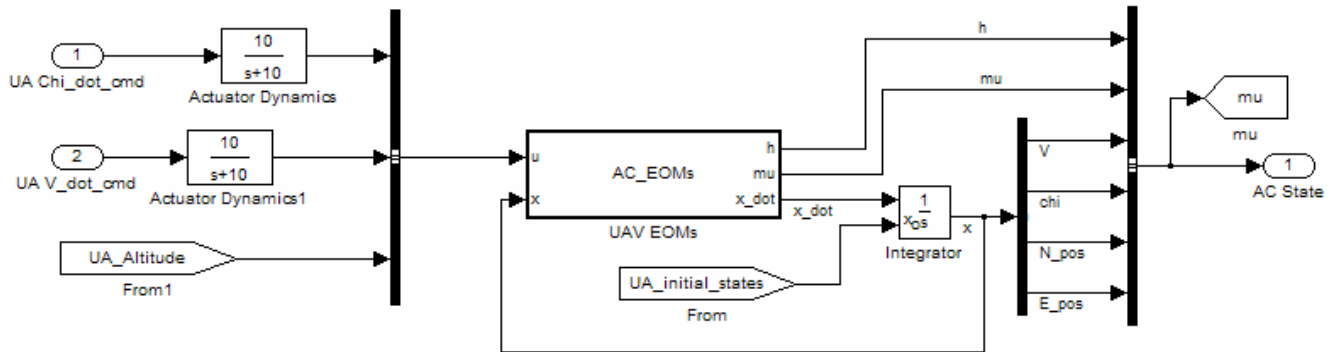

Figure 14. UA Model in Simulink

4.2.5 Camera Model

The simulator AVDS served as the camera model for the research. AVDS calls for twenty-five inputs and produces sixteen outputs. For this simulation, the six inputs of altitude, bank angle, velocity, heading angle, and north and east position were used with the remaining nineteen inputs left blank. The outputs used were simply the cursor position of the mouse in the GUI, which correspond to ΔX_{GUI} and ΔY_{GUI} . In the AVDS, the camera view can be manually adjusted to give different VFOV, HFOV, and depression angle.

4.2.6 Target Model

The target model contained an embedded MATLAB function with the same equations of motion used for the UAS. The output of the target model was connected to the AVDS simulator using the AVDS Network Send Connection (see Figure 15). The inputs are all adjustable to give flexibility in testing. The outputs also include flexibility in the actual position of the aircraft.

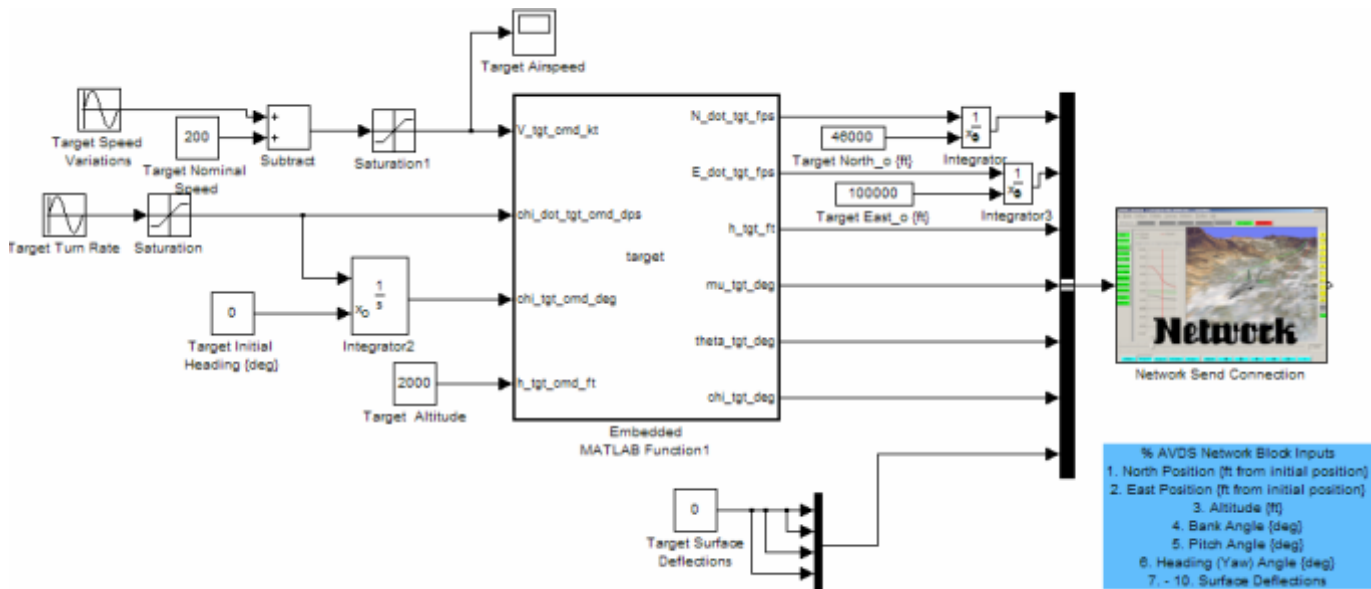

Figure 15. Target Model in Simulink

4.3 Chapter Summary

This chapter explained the computer simulation used to develop COT. MATLAB and Simulink were integrated with AVDS to provide a realistic environment in which to demonstrate an operator-in-the loop capability. The UAS simulation included five main elements: UA model, camera model, mouse position from GUI, COT control system and target model. The key component of the system, the COT controller, commands the UAS's acceleration and turn-rate, which enables an operator to track a target by positioning the mouse in the camera display GUI.

V. Proposed UAS Operator Rating Scale

5.1 Cooper-Harper Scale Background

Currently, manned aircraft test programs depend on the pilot's subjective rating of an aircraft's handling qualities. Handling qualities are defined as "those qualities or characteristics that govern the ease and precision with which the pilot is able to perform the task required in support of the aircraft's role (Liebst, 2006)." The rating scale universally accepted by test pilots to measure handling qualities is the ten point Cooper-Harper scale. The scale is broken up into levels; Level 1 is satisfactory (1-3.5), Level 2 is adequate (4-6.5), and Level 3 is tolerable (7-9), and a value of ten does not allow the plane to be flown again. The scale was created to be pilot-oriented and can be used when one does not know how to exactly quantify the results of a test. The drawbacks to the scale are the lack of design guidance and the need for compliance to standards on the part of the pilot (Hodgkinson, 1999).

5.2 Lack of current UA rating scales

The application of a scale similar to the Cooper-Harper Rating scale to UA development is a logical progression due to the dependence on the ground operator as the key element of semi-autonomous UA. In COT, the task is similar to the handling qualities test of a manned aircraft pilot. Although the use of a scale similar to the Cooper-Harper rating scale for UA is proposed for this research, use of such a scale is not currently a published widespread practice for rating UAS performance. The only published article on similar UA rating scales was written in 1992 by the Naval Air

Warfare Center. In that article titled “Flying Qualities of Remotely Piloted Vehicles,” the authors proposed an initial attempt at developing a technique to facilitate the quantification of UA flying qualities, but did not propose using the Cooper-Harper scale (Breneman, 1992). By incorporating a standard rating scale for UAS, designers could incorporate proven handling qualities from the earliest stage of design. Such a rating scaled would have provided a reference point for continuity between previous research such as the Army Research Institute’s MAV and the current project. Without a scale on which to base results, the article on the Army’s research is generally helpful, but no specific test results can be obtained.

5.3 UAS Rating Scale

The present research proposes an updated Cooper-Harper rating scale specifically applicable to handling qualities during tracking tasks (see Figure 16). The only modification to the Cooper-Harper scale are two blocks adopted from the Pilot Induced Oscillation rating scale which concern the operator entering the control loop and initiating tight control while in the loop (see Figure 17). Although proposed by a military pilot with only academic knowledge of the Cooper-Harper rating scales, this scale will hopefully provide a basis for quantifiable results when testing the preliminary COT design concept and provide a starting point of dialogue between engineers and UA ground operators.

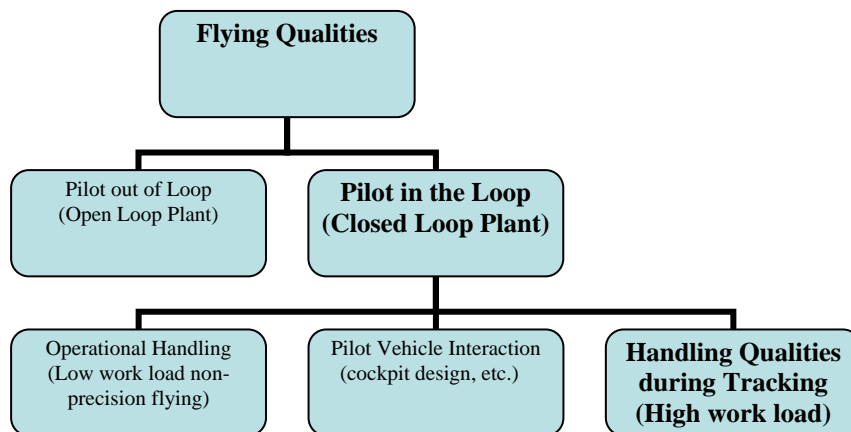

Figure 16. Handling Qualities during Tracking Diagram (Liebst, 2006)

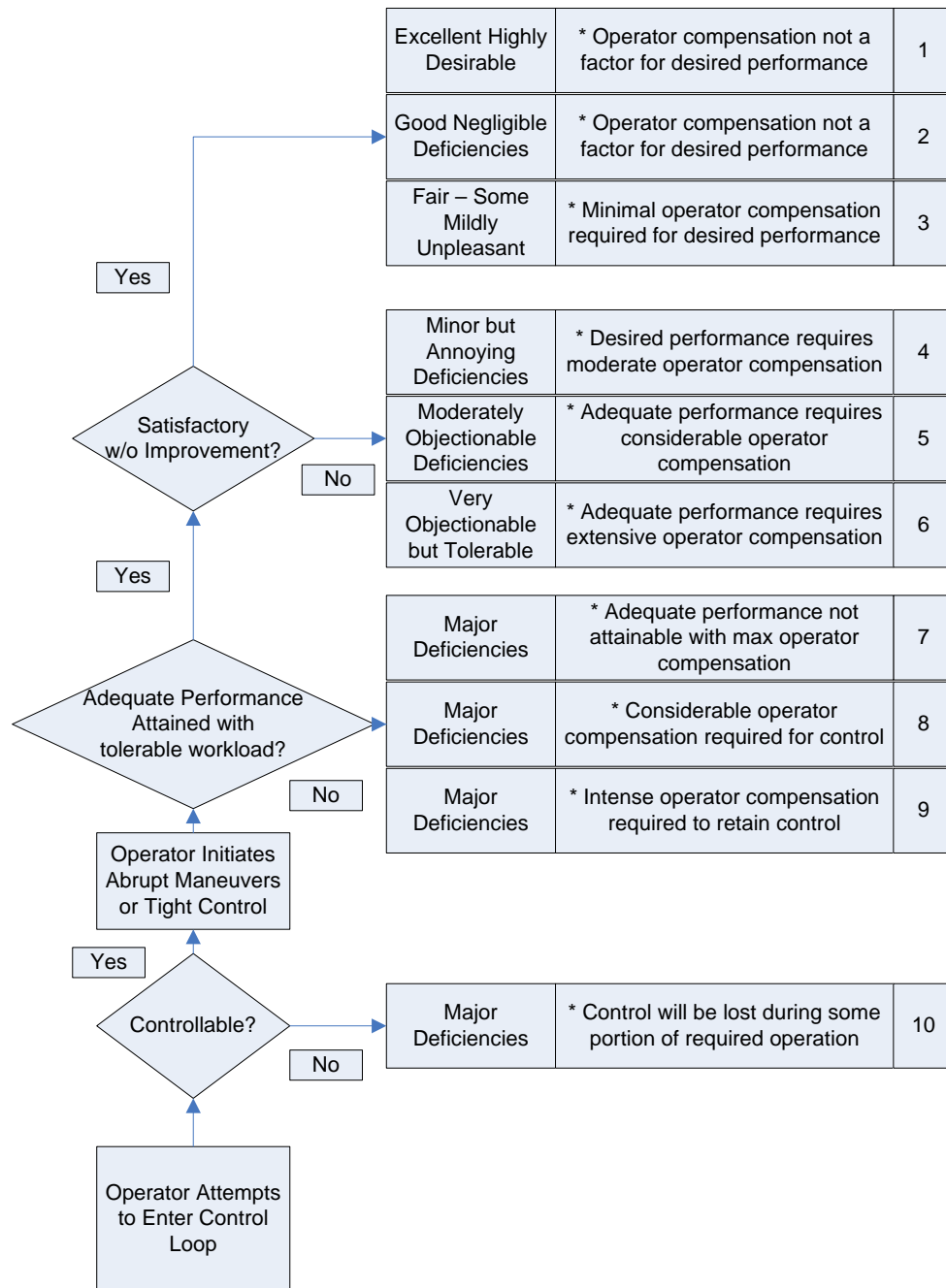

Figure 17. Proposed UAS Operator Rating Scale

VI. Demonstration and Test Results

6.1 Demonstration

The purpose of the demonstration was to show that the development of a COT controller actually works in a virtual environment. After many trial runs and much troubleshooting, the computer model operated as expected (see Figure 18). With the UAS model flying at a predetermined altitude, lateral movement as directed by the cursor acts as a turn rate controller for the aircraft model. The velocity is adjusted by acceleration control for cursor movement in the vertical plane. Although it may be considered an elementary model, it paves the way for future research and a more complicated demonstration.

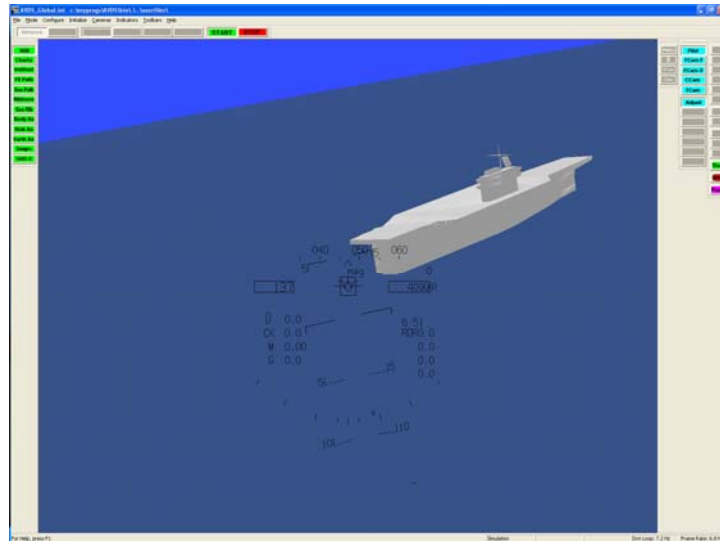

Figure 18. Demonstration of COT with Target Model in view

6.2 Test Plan

Flight testing is required at the end of any aircraft design process to validate and refine the design. Testing determines whether the aircraft and crew can safely accomplish the intended mission. Aircraft changes can be made as a result of flight tests, but the tests must be planned correctly or an endless cycle of changes will be made, potentially leading to program failure. Although the current research does not include actual flight testing, any aircraft design requires a number of preliminary ground tests prior to the first flight. Including a background and framework for testing will be beneficial for both the current computer simulation and any future work in this area of research (Kimberlin, 2003).

When planning any test, one must determine the purpose and objectives of the test program. For the current research, the purpose of testing is to determine if the developed COT controller performs correctly in realistic scenarios. Next, one should design the test and use methods to accomplish the stated objectives of demonstrating the feasibility of COT by testing various real-world scenarios. If possible, one should review previous tests for lessons learned and design the test for a specific task. In this research, no similar research was available upon which to model testing. The specific task is to keep a ground target in view of the camera. Throughout, one should conduct brainstorming sessions in order to create original ideas. In conducting the test, a group of five to ten operators will give good results (Kimberlin, 2003).

Some techniques have been developed in designing a test. First, pre-simulator briefing requires some forethought so inadvertent bias is not introduced. Second,

configurations should be randomized but begin with easier configurations. At the same time, one should expose the operator to the extremes of the configuration early on in the experiment in order to see contrast in the ratings. Lastly, operators should be given a long look at the task by allowing the configuration to be flown for two minutes and then repeated before an evaluation is given (Hodgkinson, 1999).

After searching for set procedures to follow in an aircraft test, no set standard was found because each test is unique. However, an accepted technique was proposed as follows. First, one should define the desired and adequate bounds of the test. Second, the task should be performed. Third, the operator should comment extemporaneously during the task to collect as much information as possible. Fourth, the operator should assign an initial rating using the proposed UAS operator rating scale. Fifth, detailed comments should be written using provided comment cards. Finally, the formal rating should be given to the operator and only then the quantitative performance of the flight is revealed to the operator (Kimberlin, 2003).

Such steps in the planning and implementation of the test can produce reliable and repeatable results. One key element when debriefing operators is to question why the pilots assigned a particular rating. Although the majority of operators will most likely be within one point each other, a varied response should not be discounted as it may uncover an error in the model to be tested (Kimberlin, 2003).

6.2.1 Test Plan Scenarios

Due to the preliminary nature of the research, the test scenarios were kept straightforward and simple. At the same time, the scenarios covered all realistic cases for a moving target. The case of a stationary target, a target that stops intermittently, or travels slower than the UA was not covered and will be a topic for continued research. In addition, this research only pertains to a target that is in front of the UA and circling patterns are not discussed.

Each operator was given eight, two minute scenarios in which to operate COT (see Table 2). The first scenario was a demonstration to educate the operator on the use of COT. In the second scenario, the operator was instructed to simply keep the cursor on the target, as the COT control name implies. In the remaining scenarios, the goal was to lead the target with the cursor in order to keep the target in the middle of the screen. This goal was tested in scenarios three through six with different heading and airspeed variations.

Table 2. Scenarios Flown to Evaluate COT

1. Demonstration
2. Cursor-on-Target
3. Constant Heading and Airspeed
4. Varying Heading and Airspeed
5. Constant Heading, Varying Airspeed
6. Varying Heading, Constant Airspeed
7. Adjusted Gain in Scenario # 4
8. Adjusted Gain in Scenario # 4 with Wings Level Flight

The last two scenarios had adjusted gains, with the last scenario restricted to wings level flight (see Table 2). The reason for changing the gains was twofold; first, to see if such gains influenced the ability to track the target and second, to produce a different rating number to verify that the rating scale differentiated between various scenarios. The gains were adjusted for the equations of $\frac{d\chi_{cmd}}{dt} = K \tan(\Delta\chi)$ and $\frac{dV_{CMD}}{dt} = \bar{K} \Delta Y_{GUI}$ described in section 4.2.2 . In the initial scenarios, $K = 0.1$ and $\bar{K} = 125$ which after trial and error were adjusted to $K = 5$ and $\bar{K} = 10$. The adjustment of K caused the most influence on operator ratings due to the instability it caused in scenario seven when the cursor was adjusted in the vertical plane.

Although subjective and conducted by operators with minimal rating experience, the test did give a baseline to at least discuss COT. Overall, the operators rated the COT relatively well. For the four basic scenarios, only two operators gave ratings outside of Level 1 (see Figure 19). Of particular note are scenarios four, seven and eight of the

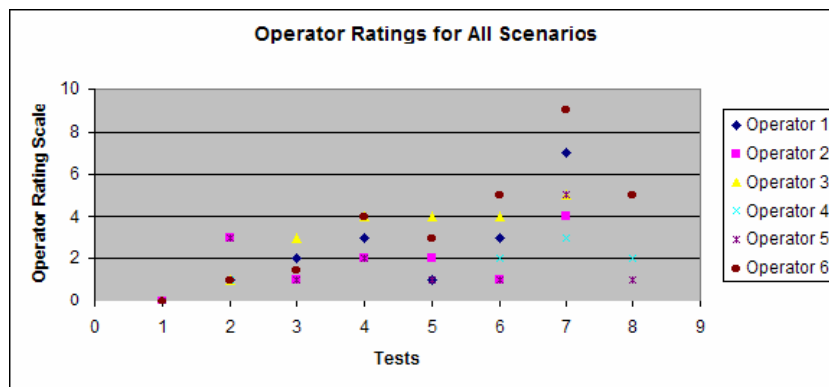

Figure 19. Operator Rating Results for Various Scenarios

target with varying heading and airspeed (See Figure 20). When the gain values were increased in scenario seven, all operators rated the COT controller worse and only one operator rated it Level 1. Yet, with the same increased gains but wings level flight, two of the three operators tested rated COT equal or better than with the beginning gains

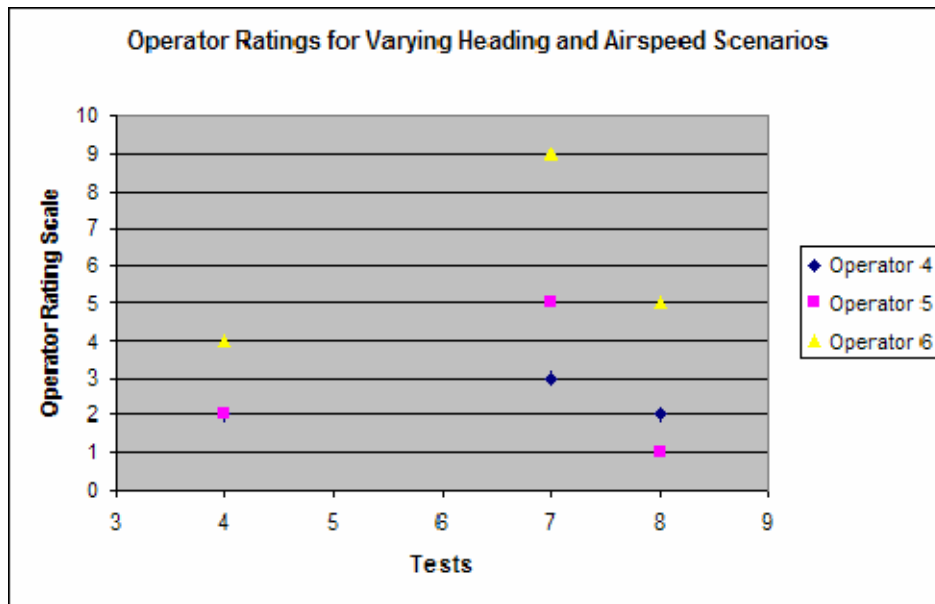

Figure 20. Operator Rating Results for Varying Heading and Airspeed Scenarios

which included bank angle. From this simple task, minimizing bank angle seemed to correlate with better tracking by the operator and may be worthy of continued research.

VII. Recommendations and Conclusions

7.1 Recommendations for Future Work

Although this research produced a preliminary COT control system, much improvement can be made to bring the concept closer to an operational reality. In particular, the following suggestions are made for future work:

- A more sophisticated COT control law should be developed in order to respond better to target movements (e.g. PID).
- Wind influence on the equations of motion must be considered as it has a direct impact on small UA flight.
- Development of more in-depth equations of motion should be made so altitude can become a variable.
- More realistic test scenarios should be developed for stopped, stop and go, and slow moving targets.
- Camera views as described in previous research should be investigated, particularly side-facing cameras.
- This research did not include the opinion of any real-world UA operators. Such inputs would be valuable for both the test plan and COT development.
- One should consider additional measures of performance such as average and maximum distance of the target from center, and the operator's ability to keep the target within defined bounds.

- The COT should be tested with hardware-in-the-loop, including live video testing, and then be flown on a UA to validate that COT works operationally.

7.2 Additional Comments

Since camera optics is a vital portion of UA, future researchers interested in this field should consider taking an optics class to better understand sensor equipment. After completing this research, the author thinks it would be beneficial to institute a standardized UA test operator training program similar to the various Services Test Pilot schools.

7.3 Conclusions

The goal of this research was to develop and evaluate a COT control system in order to decrease operator workload during high task phases of flight and to develop a method of evaluating a COT control system. The development goal has been accomplished by creating a combined Simulink-AVDS simulation which included a UAS and target model. In the simulation, a COT controller was developed and the concept was demonstrated. The Operator Rating Scale was demonstrated as a tool to evaluate UAS guidance and control and the results proved favorable. This provided a way to compare current research to future research based upon a time tested model rating scale. Hopefully, this research will pave the way for future exploration of ways to control UA that do not require in-depth training for the operator!

Appendix A : Rating Scales

Cooper Harper Rating Scale

Cooper-Harper Scale

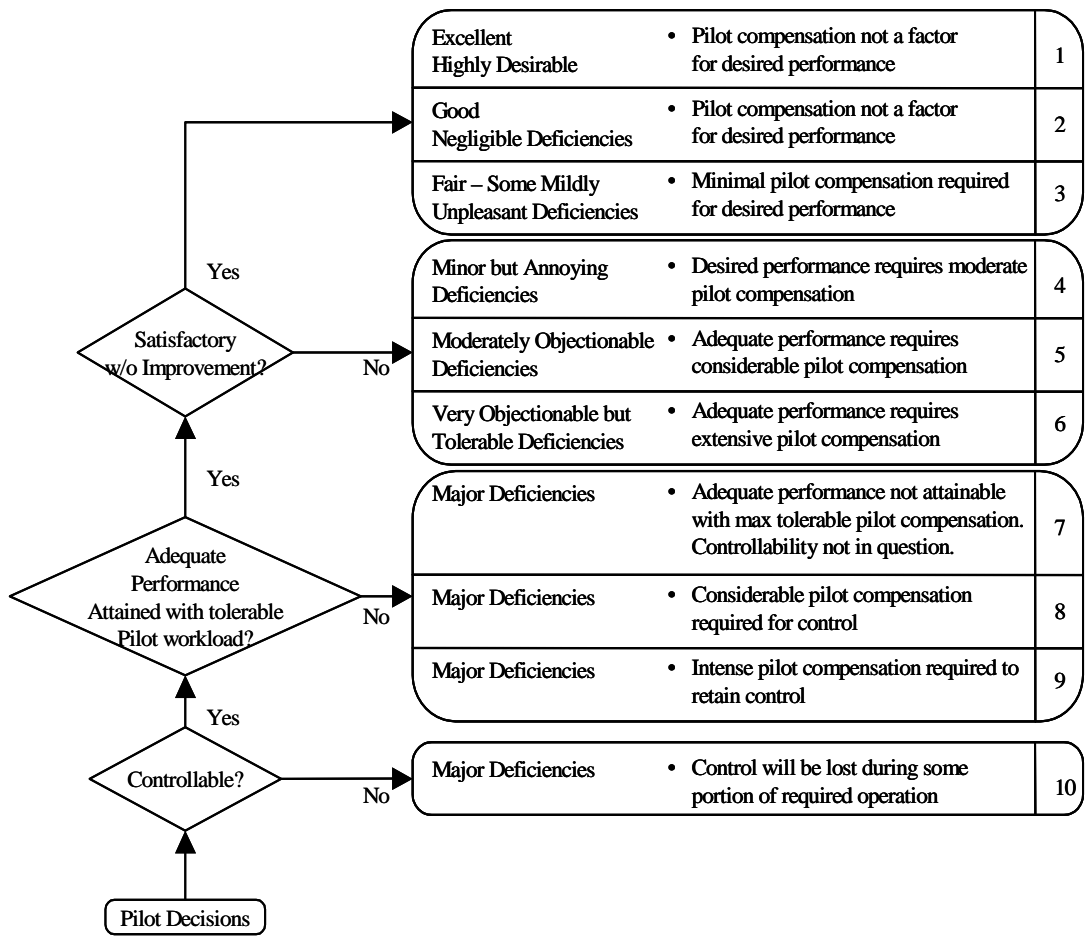

Pilot Induced Oscillation Rating Scale

PIO Rating Scale

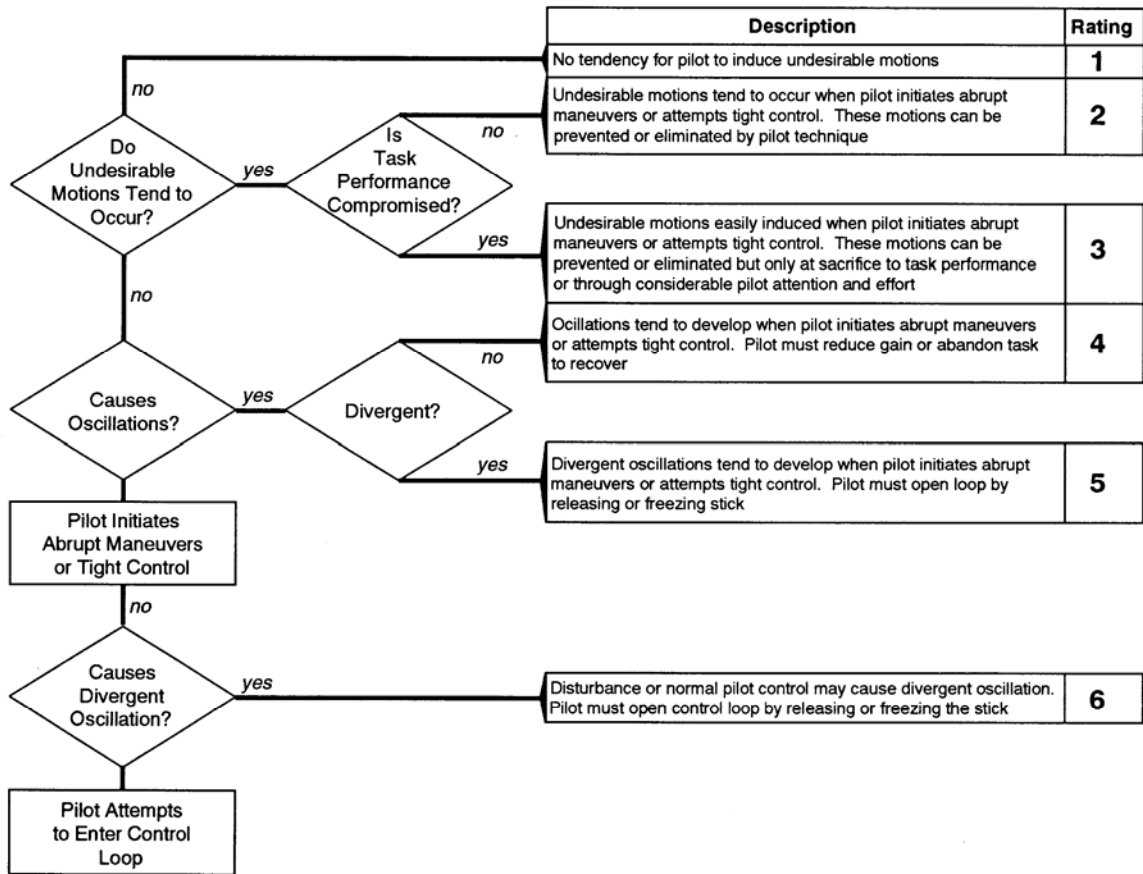

Appendix B: Simulink Diagrams

B.1 Top Tier View

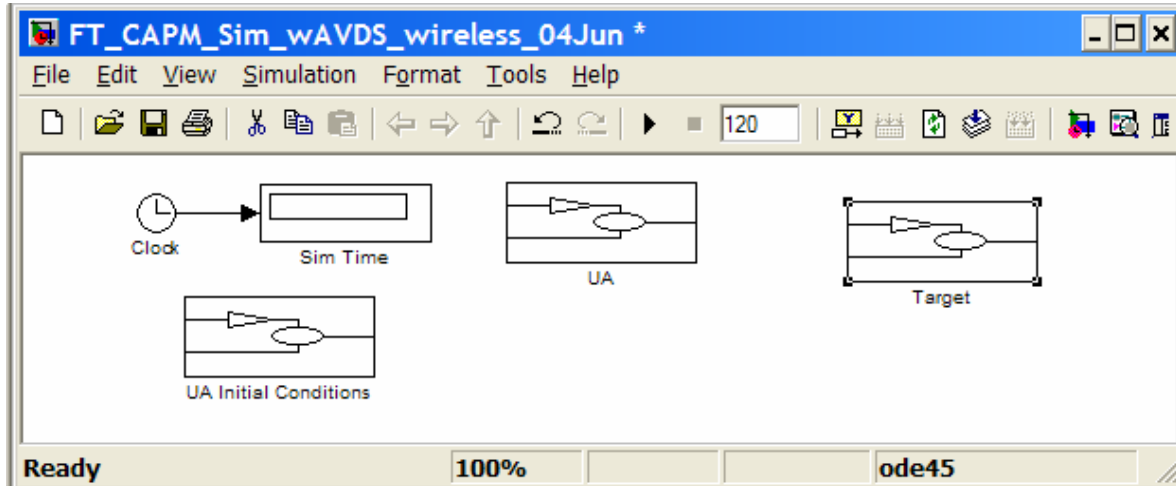

B.1.1 UA Initial Conditions

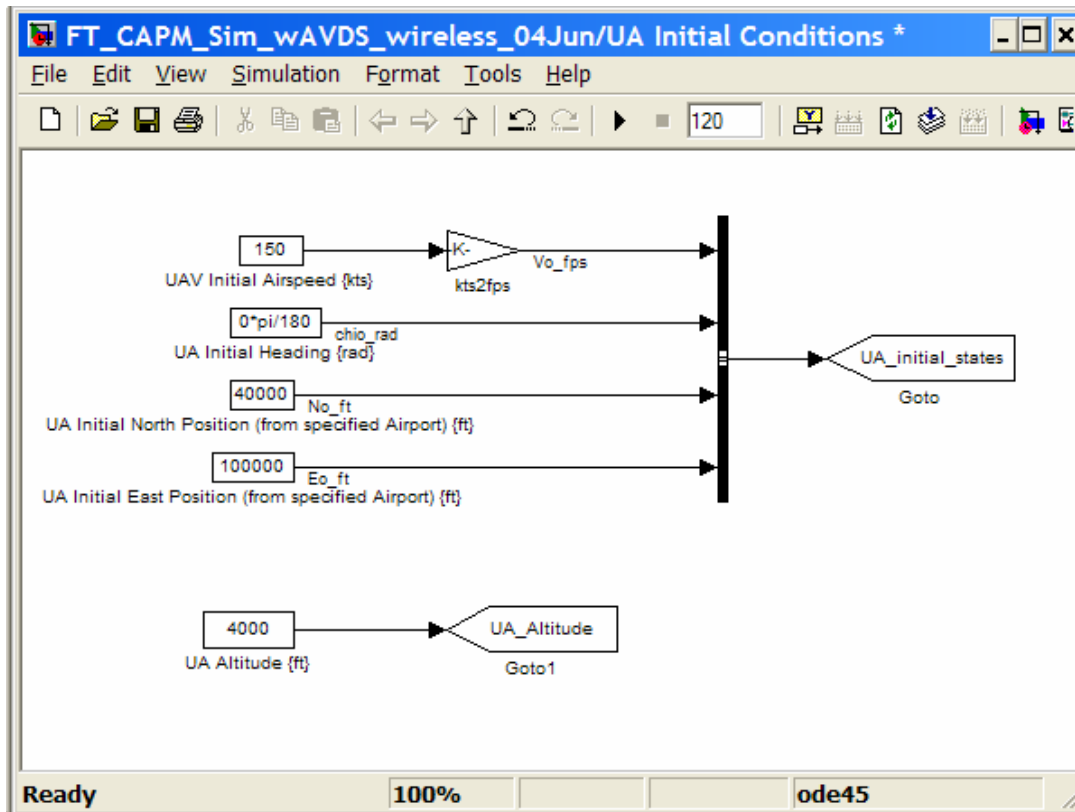

B.1.2 Unmanned Aircraft System

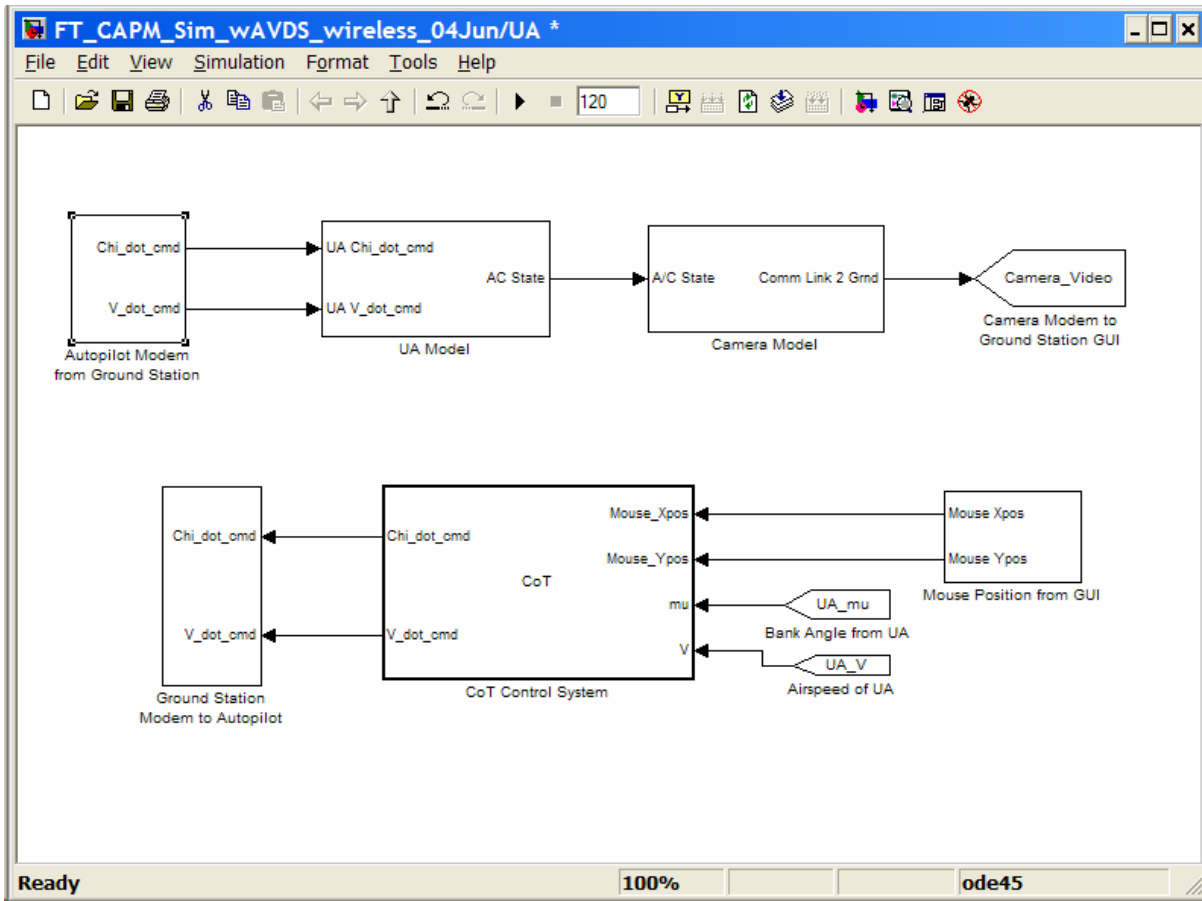

B.1.2.1 Autopilot Modem from Ground Station

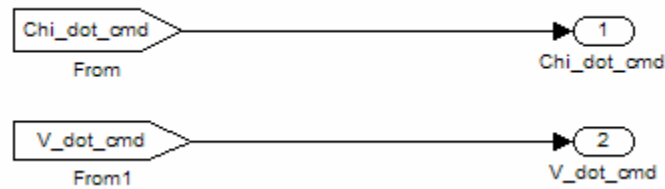

B.1.2.2 UA Model

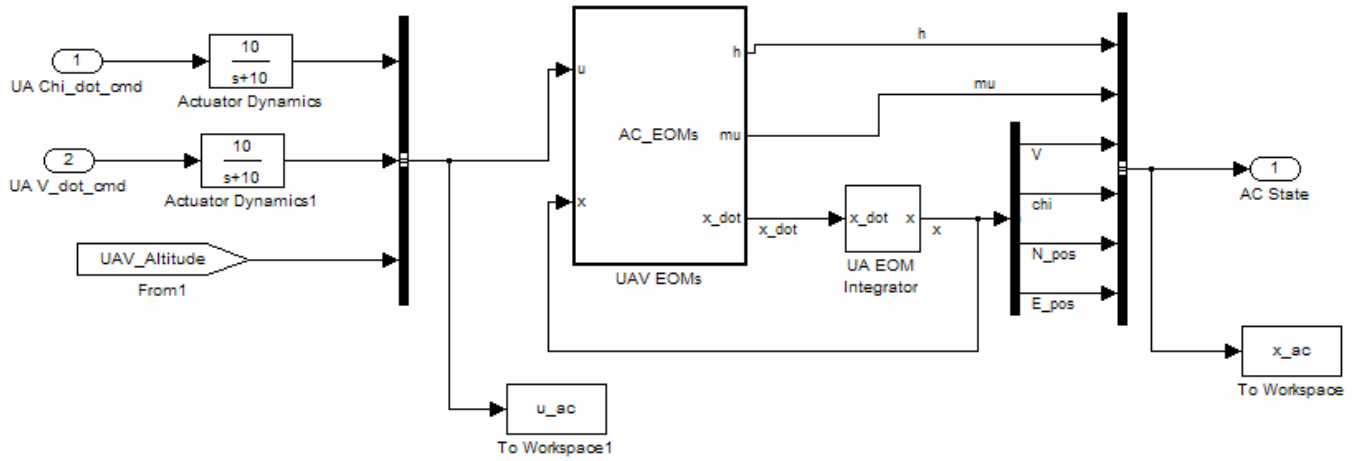

B.1.2.2.1 X1-X4 Integration

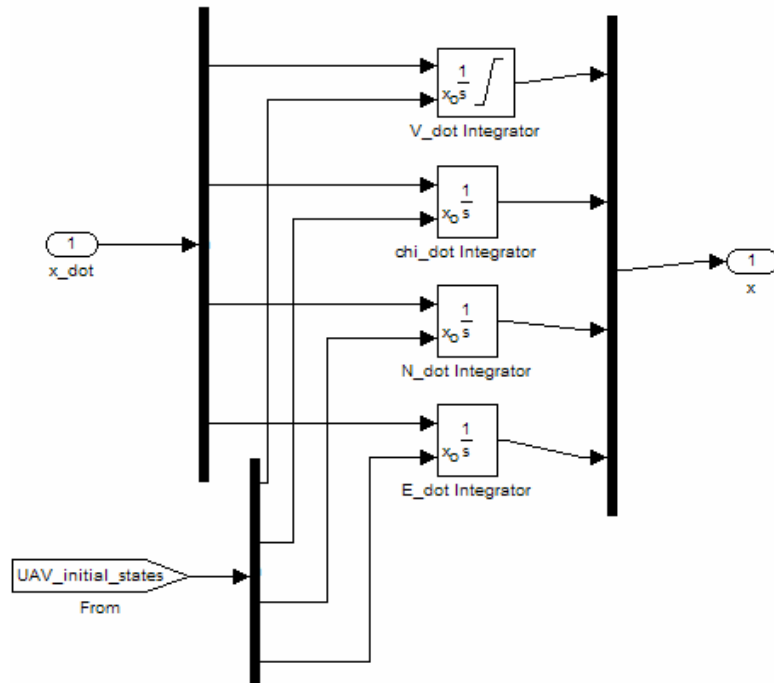

B.1.2.2.2 Embedded MATLAB Function

```

function [h,mu,x_dot]=AC_EOMs(u,x)

% EOMS for a PT MASS A/C at Constant Altitude
% *** QUANTITY ***** UNITS *****
% *** length      -> {ft}
% *** velocity    -> {ft/s}
% *** acceleration-> {ft/s^2}
% *** angles      -> {radians} (calculations)
% *** ang. vel.   -> {rad/s}
% *****

% EXTRACT INPUTS FORM INPUT VECTOR

%% Inputs used for constant altitude point-mass simulation
chi_dot_cmd = u(1); % Turn Rate Command (radians/sec)
V_dot_cmd   = u(2); % Acceleration Command {ft/s^2}
h_cmd       = u(3); % Commanded Altitude {ft}

% EXTRACT STATES FROM INPUT STATE VECTOR
V      = x(1); % Velocity {ft/s}
chi     = x(2); % Heading {radians}
N_pos  = x(3); % North Position {ft}
E_pos  = x(4); % East Postion {ft}

% Define and/or Calculate Necassary Constants
d2r=pi/180;
r2d=180/pi;
g=32.17;

% ----- NONLINEAR Point Mass EQUATION OF MOTION (EOMS) -----
% % These are the state derivative equations; the comment names the state,
% % but the equation is for its derivative (rate)

% Velocity
V_dot=V_dot_cmd;

% Heading
chi_dot=chi_dot_cmd;

% North Position
N_dot=V*cos(chi);

% East Position
E_dot=V*sin(chi);

% Pack derivatives into output vector x_dot
x_dot=[0;0;0;0];
x_dot(1) = V_dot;
x_dot(2) = chi_dot;
x_dot(3) = N_dot;
x_dot(4) = E_dot;

% Finally, calculate bank angle, which can be estimated based on known
% states and rates
h=0;
mu=0;
h=h_cmd;
mu=atan2(V*chi_dot,g);

return

```

B.1.2.3 Camera Model

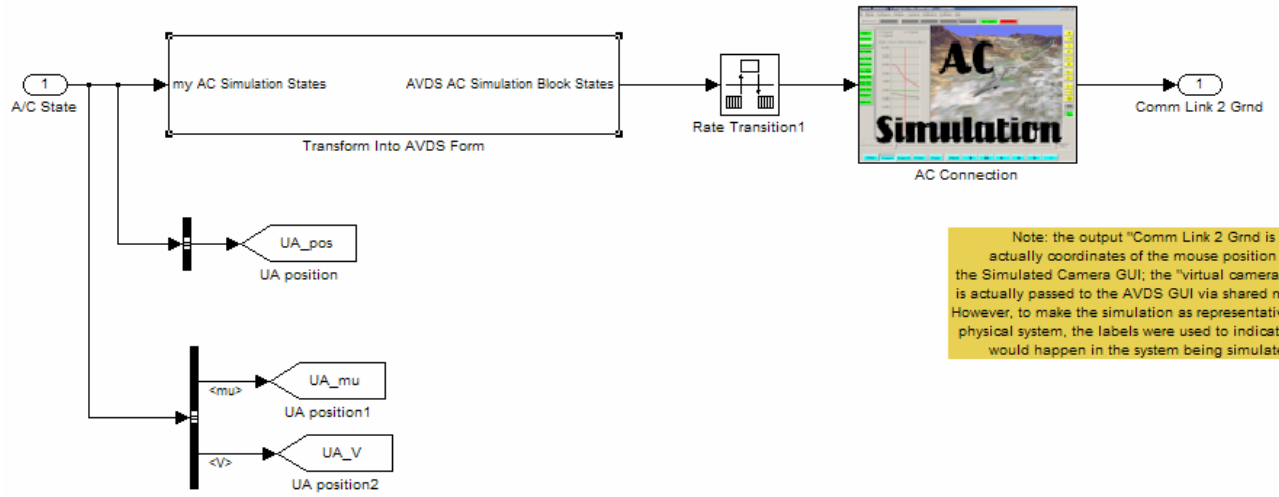

B.1.2.3.1 Camera Model Transformation into AVDS Form

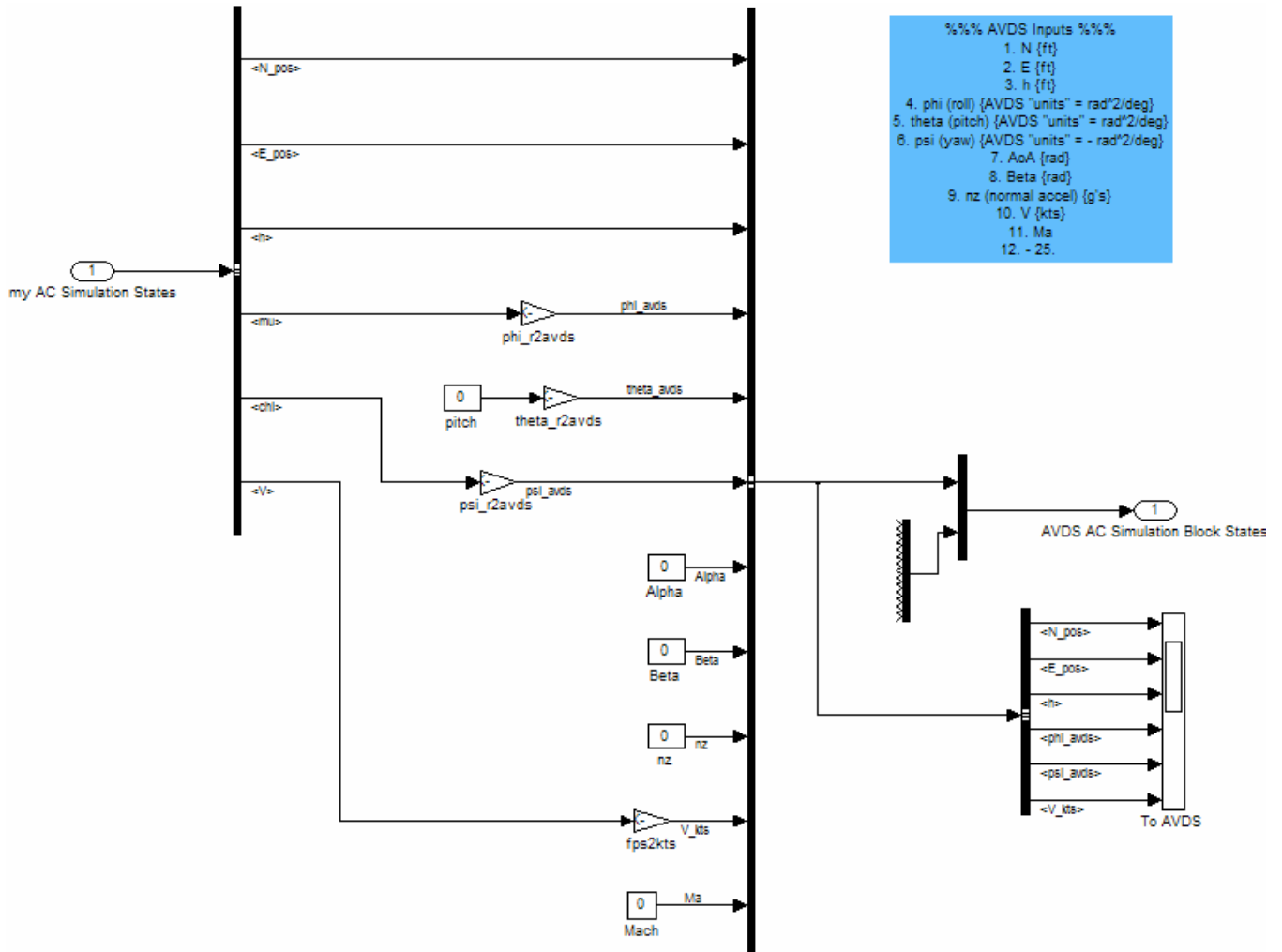

B.1.2.4 COT Control System Embedded MATLAB Function

```
function [Chi_dot_cmd,V_dot_cmd] = CoT(Mouse_Xpos,Mouse_Ypos,mu,V)

% COT Control System

% DEFINE Camera Geometry
CHFOV=60*pi/180; % Camera Horizontal Field of View
% For future use
CVFOV=60*pi/180; % Camera Vertical Field of View
Ctheta=-45*pi/180; % Camera "pitch" angle above a/c nose (currently
set in AVDS)
Cpsi=0*pi/180; % Camera "yaw" angle right of a/c nose (currently
set in AVDS)
Czoom=1; % Camera zoom (currently set in AVDS)
% Set Constants
mu_max=45*pi/180;
g=32.17;
V_dot_max=1*g; % {ft/s^2}
V_dot_min=-1*g; % {ft/s^2}
% delta_chi=-Mouse_Xpos*CHFOV/2;
Kpp=.1;
% Chi_dot_cmd=Kpp*delta_chi;
% Chi_dot_cmd=Kpp*tan(delta_chi);
% Chi_dot_cmd=.1*tan(-Mouse_Xpos*pi/2);
Kvdot=125;
%V_dot_cmd=Kvdot*tan(Mouse_Ypos*pi/2);
%mu=0; % Wings level demo
delta_H=Mouse_Xpos*cos(mu)-Mouse_Ypos*sin(mu);
delta_V=Mouse_Xpos*sin(mu)+Mouse_Ypos*cos(mu);
%V_dot_cmd=Kvdot*Mouse_Ypos;
V_dot_cmd=Kvdot*delta_V;
%Chi_dot_cmd=.1*tan(-delta_E*pi/2);
%V_dot_cmd=Kvdot*tan(delta_N*pi/2);
delta_chi=-delta_H*(CHFOV/2);
Chi_dot_cmd=Kpp*tan(delta_chi);
% Set Turn-Rate Limit based on bank angle
chi_dot_max=g/V*tan(mu_max);
%Now check if commanded turn rate inside limits
if(Chi_dot_cmd > chi_dot_max)
    Chi_dot_cmd=chi_dot_max;
elseif(Chi_dot_cmd < -chi_dot_max)
    Chi_dot_cmd=-chi_dot_max;
end
% Set Acceleration Limit based on UA performance limits
%Now check if commanded accel inside limits
if(V_dot_cmd > V_dot_max)
    V_dot_cmd=V_dot_max;
elseif(V_dot_cmd < V_dot_min)
    V_dot_cmd=V_dot_min;
End
```

B.1.2.5 Ground Station Modem to Autopilot

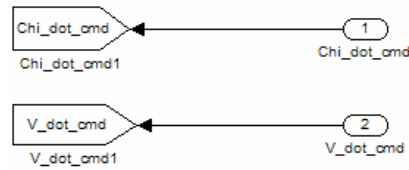

B.1.3 Target Model

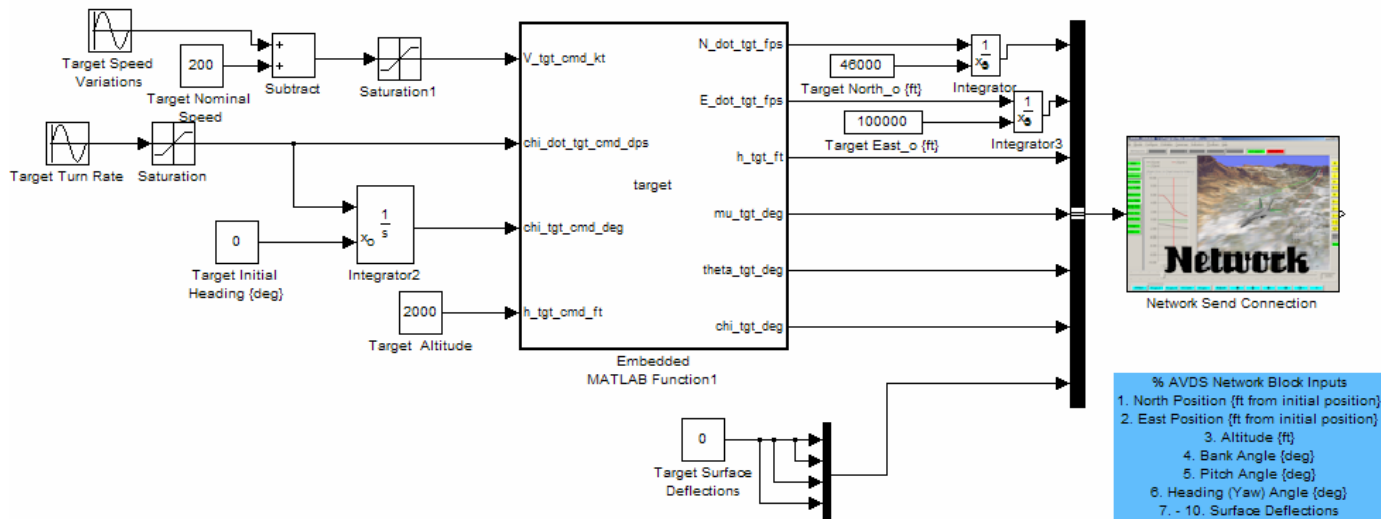

B.1.3.1 Target Embedded MATLAB Function

`function`

```
[N_dot_tgt_fps,E_dot_tgt_fps,h_tgt_ft,mu_tgt_deg,theta_tgt_deg,chi_tgt_deg] =
target(V_tgt_cmd_kt,chi_dot_tgt_cmd_dps,chi_tgt_cmd_deg,h_tgt_cmd_ft)
```

```
d2r=pi/180; % degrees to radians
r2d=180/pi; % radians to degrees
kt2fps=1.689; %knots to feet per second
g_fps=32.2; % accel due to gravity {fps^2}
V_tgt_fps=V_tgt_cmd_kt*kt2fps;
N_dot_tgt_fps=V_tgt_fps*cos(chi_tgt_cmd_deg*d2r);
E_dot_tgt_fps=V_tgt_fps*sin(chi_tgt_cmd_deg*d2r);
h_tgt_ft=h_tgt_cmd_ft;
mu_tgt_deg=atan2(V_tgt_fps*chi_dot_tgt_cmd_dps*d2r,g_fps)*r2d;
theta_tgt_deg=0;
chi_tgt_deg=chi_tgt_cmd_deg;
```

Bibliography

- Allard, Wayne. United States Senator, Colorado. Speech in Washington, D.C. 19 March 2007
http://allard.senate.gov/public/index.cfm?FuseAction=PressReleases.Detail&PressRelease_id=232154&Month=3&Year=2007 .
- Breneman, Kevin and Lower, Mark. "Flying Qualities of a Remotely Piloted Vehicle," AIAA Biennial Flight Test Conference, 6th, Hilton Head Island, SC, August 1992.
- Burns, Brian S. *Autonomous Unmanned Aerial Vehicle Rendezvous for Automated Aerial Refueling*. MS Thesis, AFIT/GAE/ENY/07-M05. School of Engineering and Management, Air Force Institute of Technology (AU), Wright-Patterson AFB, OH. March 2007.
- Byrne, Rich. "Cursor on Target Improves Efficiency," The Mitre Corporation, 6 January 2005 www.mitre.org/news/the_edge/fall_04/byrne.html .
- Cook, Nancy J. and others. *Human Factors of Remotely Operated Vehicles*. Amsterdam, The Netherlands: Elsevier JAI Press, 2006.
- Curry, David G., "Target Designation by Speech, Joystick, and Touch Control: Format Design Implications," IEEE Proceeding of the National Aerospace and Electronics Conference, pg. 923, Air Force Dynamics Laboratory, Wright-Patterson AFB, Ohio, 1985.
- Dugan, Joseph M. *Situational Awareness and Synthetic Vision for Unmanned Aerial Vehicle Flight Testing*. MS Thesis, AFIT/GAE/ENY/06J-03. School of Engineering and Management, Air Force Institute of Technology (AU), Wright-Patterson AFB, OH. June 2006.
- Frew, Eric and others, "Vision-Based Road-Following Using a Small Autonomous Aircraft," IEEE AC paper #1479, Version 3, 5 January 2004.
- Garnell, P. *Guided Weapon Control Systems*. Oxford, New York: Pergamon Press, 1980.
- Garrett, Knowlan and Phillips, Craig, "White Paper: Analysis of Risk Associated with Integrating Sensors on Micro UAVs," Air Force Institute of Technology (AU), Wright Patterson AFB, OH, 2007.
- Glassco, Roy G. *Closely Supervised Reactive Control of an Uninhabited Aerial Vehicle*. MS Thesis, AFIT/GAE/ENY/99J-01. School of Engineering and Management, Air Force Institute of Technology (AU), Wright-Patterson AFB, OH. June 1999.

- Goodall, Christopher, "Problem Statement and Requirements for Gimbaled Camera for the Coyote UAV," September 2005
<http://classes.engr.arizona.edu/engr498a/2005/acruavaz/textout.php?opendoc=Problem+Statement+and+Requirements+9-22-2005.txt>
- Halloran, Richard. "China's Path to Power – Sub Buildup Key to Naval Strategy," *The Navy Times*, 21 May 2007.
- Hodgkinson, John. *Aircraft Handling Qualities*. Reston, VA: AIAA, 1999.
- Jianchao, Yao, "A New Scheme of Vision Based Navigation for Flying Vehicles – Concept Study and Experiment Evaluation," Seventh International Conference on Control, Automation, Robotics and Vision, Singapore, December 2002.
- Kimberlin, Ralph D. *Flight Testing of Fixed-Wing Aircraft*. Reston, VA: AIAA, 2003.
- Lewis, Sharon M. and others. *Medical-Surgical Nursing, Fifth Edition*. St. Louis, Missouri: Mosby, Inc., 2000.
- Liebst, Bradley S. "Mech 629 – Aircraft Handling Qualities and Performance," Air Force Institute of Technology Department of Aeronautics and Astronautics, Wright Patterson AFB, OH, Summer 2006.
- Liggett, Kristen, K. and others, "An examination of cursor control techniques to designate targets on a cockpit map display," SPIE Vol. 2462, Advanced Cockpit Branch, Wright-Patterson AFB, OH, 1995.
- Lundington, Ben, and others, "Augmenting UAV Autonomy – Vision-Based Navigation and Target Tracking for Unmanned Aerial Vehicles," IEEE Robotics and Automation Magazine. September 2006.
- Miller, William, "Cursor on Target," Military Information Technology Online Edition, Volume 8, Issue 7, 2 September 2004
<http://www.military-information-technology.com/article.cfm?DocID=596> .
- Minor, John L. *Flight Test and Evaluation of Electro-Optical Sensor Systems*. USAF Test Pilot School. Edwards AFB, CA 93524-6485, 2002.
- Morphew, Ephimia E. and others, "Helmet Mounted Displays for Unmanned Aerial Vehicle Control," Proceedings of SPIE Vol. 5442. Aeroflightdynamics Directorate, US Army Aviation and Missile Research, Ames Research Center, Moffett Field, CA. April, 12, 2004.

- Peck, Michael, "Undersized Drone Promises Extended Maritime Surveillance,"
January 2006
http://www.nationaldefensemagazine.org/issues/2006/jan/UF_Undersized.htm .
- Pike, John, "Broad Area Maritime Surveillance," December 2006
<http://www.globalsecurity.org/intell/systems/bams.htm> .
- Proctor, Alison A. and Johnson, Eric N., "Vision-Only Aircraft Flight Control Methods and Test Results," AIAA Guidance, Navigation, and Control Conference and Exhibit 16-19, Providence, Rhode Island, August 2004.
- Purves, Dale "The answer indicated by perceptual evidence," Laboratory of Dale Purves, Center for Cognitive Neuroscience, Duke University, May 2007
<http://www.purveslab.net/research/> .
- Rasmussen Simulation Technologies, LTD. *Aviator Visual Design Simulator User Manual*. February 2005.
- Rolfen, Bruce. "Who will fly unmanned aircraft? Army, Air Force officers square off," *The Air Force Times*, 16 April 2007.
- Rufa, Justin R. *Development of an Experimental Platform for Testing Autonomous UAV Guidance and Control Algorithms*. MS Thesis, AFIT/GAE/ENY/07M-20. School of Engineering and Management, Air Force Institute of Technology (AU), Wright-Patterson AFB, OH. March 2007.
- Roosevelt, Ann., "JFCOM Experiment Shows How Dissimilar Systems Can Communicate" *Defense Daily*, 1 February 2005.
- Sherman, Kenneth B., "US Navy Studies Aircraft-Launched UAV," *The Journal of Electronic Defense*, pages 21-22, January 2006.
- The MathWorks, *Learning Simulink 6 - Fifth Edition*, 2004.
- Trinh, Tan T. and Kuchar, James K. "Study of Visual Cues for Unmanned Aerial Vehicle Waypoint Allocation." IEEE, Massachusetts Institute of Technology, Cambridge, MA, 1999.
- United States. "Operational Requirements Document/Capability Development Document for the Multi-Mission Maritime Aircraft," March 2003.
- United States. "Unmanned Aircraft Systems Roadmap, 2005-2030," Department of Defense, July 2005.

United States. Maritime Surveillance Aircraft Program Office. "The PMA-290 Newsletter," Issue 19, Spring 2006.

Veth, Michael J. *Fusion of Imaging and Inertial Sensors for Navigation*. Air Force Institute of Technology (AU), Wright-Patterson AFB, OH. September 2006.

Wehrman, Jessica, "Unmanned Vehicles Plan Meets Opposition," *Dayton Daily News*, 20 April 2007, sec. A:10.

REPORT DOCUMENTATION PAGE			<i>Form Approved OMB No. 074-0188</i>		
<p>The public reporting burden for this collection of information is estimated to average 1 hour per response, including the time for reviewing instructions, searching existing data sources, gathering and maintaining the data needed, and completing and reviewing the collection of information. Send comments regarding this burden estimate or any other aspect of the collection of information, including suggestions for reducing this burden to Department of Defense, Washington Headquarters Services, Directorate for Information Operations and Reports (0704-0188), 1215 Jefferson Davis Highway, Suite 1204, Arlington, VA 22202-4302. Respondents should be aware that notwithstanding any other provision of law, no person shall be subject to a penalty for failing to comply with a collection of information if it does not display a currently valid OMB control number.</p> <p>PLEASE DO NOT RETURN YOUR FORM TO THE ABOVE ADDRESS.</p>					
1. REPORT DATE (DD-MM-YYYY) 14-06-2007		2. REPORT TYPE Master's Thesis		3. DATES COVERED (From – To) June 2005 – June 2007	
4. TITLE AND SUBTITLE Development of Cursor-on-Target Control for Semi-Autonomous Unmanned Aircraft Systems			5a. CONTRACT NUMBER		
			5b. GRANT NUMBER		
			5c. PROGRAM ELEMENT NUMBER		
6. AUTHOR(S) Crouse, Joshua D., LT, USN			5d. PROJECT NUMBER		
			5e. TASK NUMBER		
			5f. WORK UNIT NUMBER		
7. PERFORMING ORGANIZATION NAMES(S) AND ADDRESS(S) Air Force Institute of Technology Graduate School of Engineering and Management (AFIT/EN) 2950 Hobson Way WPAFB OH 45433-7765			8. PERFORMING ORGANIZATION REPORT NUMBER AFIT/GAE/ENY/07-J04		
9. SPONSORING/MONITORING AGENCY NAME(S) AND ADDRESS(ES) NA			10. SPONSOR/MONITOR'S ACRONYM(S)		
			11. SPONSOR/MONITOR'S REPORT NUMBER(S)		
12. DISTRIBUTION/AVAILABILITY STATEMENT APPROVED FOR PUBLIC RELEASE; DISTRIBUTION UNLIMITED.					
13. SUPPLEMENTARY NOTES Advisor: Major Paul A. Blue, (937) 255-3636, ext 4714 paul.blue@afit.edu					
14. ABSTRACT The research presented in this thesis focuses on developing, demonstrating, and evaluating the concept of a Cursor-on-Target control system for semi-autonomous unmanned aircraft systems. The Department of Defense has mapped out a strategy in which unmanned aircraft systems will increasingly replace piloted aircraft. During most phases of flight autonomous unmanned aircraft control reduces operator workload, however, real-time information exchange often requires an operator to relay decision changes to the unmanned aircraft. The goal of this research is to develop a preliminary Cursor-on-Target control system to enable the operator to guide the unmanned aircraft with minimal workload during high task phases of flight and then evaluate the operator's ability to conduct the mission using that control system. For this research, the problem of Cursor-on-Target control design has multiple components. Initially, a Cursor-on-Target controller is developed in Simulink. Then, this controller is integrated into the Aviator Visual Design Simulator to develop an operator-in-the-loop test platform. Finally, a ground target is simulated and tracked to validate the Cursor-on-Target controller. The Cursor-on-Target control system is then evaluated using a proposed operator rating scale.					
15. SUBJECT TERMS UA, UAS, Unmanned Aircraft, Unmanned Aircraft Systems, Simulink design, UAS Operator Rating Scale, Cursor on Target, Semi-autonomous Unmanned Aircraft, Aviator Visual Design Simulator, Modeling, Simulation, Development					
16. SECURITY CLASSIFICATION OF:		17. LIMITATION OF ABSTRACT UU	18. NUMBER OF PAGES 81	19a. NAME OF RESPONSIBLE PERSON Paul A. Blue, Maj, USAF AFIT/ENY	
a. REPORT U	b. ABSTRACT U			c. THIS PAGE U	19b. TELEPHONE NUMBER (Include area code) (937) 255-6565, ext 4714; e-mail: paul.blue@afit.edu

Standard Form 298 (Rev. 8-98)
Prescribed by ANSI Std. Z39-18