

We are IntechOpen, the world's leading publisher of Open Access books Built by scientists, for scientists

4,800

Open access books available

122,000

International authors and editors

135M

Downloads

Our authors are among the

154

Countries delivered to

TOP 1%

most cited scientists

12.2%

Contributors from top 500 universities



WEB OF SCIENCE™

Selection of our books indexed in the Book Citation Index
in Web of Science™ Core Collection (BKCI)

Interested in publishing with us?
Contact book.department@intechopen.com

Numbers displayed above are based on latest data collected.

For more information visit www.intechopen.com



Energy Consumption Model for Green Computing

*Jesus Hamilton Ortiz, Fernando Velez Varela
and Bazil Taha Ahmed*

Abstract

This chapter shows the environmental measurement factors that define the indicators within an architecture composed of Goods, Networks and Services (GNS). These references are obtained from the energy consumptions in the measurement processes. This lets obtaining several analyses important from the behavior in the energy consumption schemes. The application of these factors was determined from the energy generation processes, whose units are in metrics adequate for electricity and heat according to each system observed, and the same from the energetic consumption of the same data centers that helped to determine these characteristics. These indicators applied in an environment of Information and Communications Technology (ICT) define comparisons and be specified as the basis characterizing the analysis of energetic performance. The tests show the energy consumption and carbon footprint. This experiment seeks to increase the quality of services and decrease the energy consumption. This let us use efficiently the computational resources minimizing the environment impact. To achieve this target, it was used to apply indicators in green computing environment, like it can be mentioned: The Power Usage Effectiveness (PUE) and Data Center Effectiveness (DCE). With the use of these indicators can derive a generic model of energy consumption for a GNS system.

Keywords: GNS, ICT, MIB, data center, telecommunications, energy, QoS

1. Introduction

To specify a generic model of energy consumption, it is necessary to have flexibility and support in relation to the mechanisms determined in a centralized administration, by means of a network management console, which is responsible for autonomously reviewing all the individual devices and functionally they represent them [1].

To define this, it begins with the aspects that are defined to adapt and apply the standards of observation and measurement provided by the International Telecommunications Union (ITU) for a GNS environment, which is composed of Information Technology (IT) equipment, in which the behavior of energy consumption is determined, to level of the system and components [2].

In order to specification and determination of class of Management Information Base (MIB), it is necessary to know the concept of energy consumption in an

architecture of a GNS system, and furthermore it is necessary to have a reference of the objects that is related to the energy consumption. In this part are applied the management parameters, which are necessary for the control of the measurement, all this functions can be included at the level of use of an interface, in accordance with the Quality of Service (QoS) parameters and management protocols required of the network [1].

The attributes that are controlled and monitored in IT team are: OFF state, SLEEP state, and ON state. If a network device is powered on, it may be transmitting or receiving packets on its interfaces. If it is inactive, it could be in a suspended state to save energy. By this, the main objective of controlling the configuration of energy management is to minimize the time in the ON state in favor of the time in SLEEP, maintaining a level of QoS in accordance with the efficient energy consumption.

Therefore, it is a good practice to have the ability of controlling the total and current mode of the ON state (active and inactive), the mode SLEEP, the OFF times, and QoS attributes defined per user, per application, and per interface. In the same way, it is necessary to be considered the ability to access the power management configuration (specifically, modes ON, SLEEP, and OFF). Also it is desirable to review all individual components of device architecture, such as network cards, processors, hard drives, and physical ports, and it is also necessary to take into account some characteristics of the traffic, like packet size and delay, that are measured in each port of the network equipment; this also affects the power consumption, and these initiatives are measured, reviewed, compared, and analyzed like as a complete system by a process of Power Management (PM) [3].

On the other hand, the task is to apply the extrapolation of the energy management model, in which a transition model of energy states is determined for everything related to the individual level of the network device, and it is clear that this can be used for a single network device, but it can also be used for an entire network, and this is achieved using a MIB for energy consumption management [1].

The mathematical process begins with the use of specific considerations of the operation of a device, among which are assuming a state of energy of these. In this case, a network device may show that there is dependence on the type of traffic that may be arriving; with this it can be determined how many subcomponents can be affected within their operational state, from this the transition time required to obtain the final state can be determined, and therefore, the optimal power control parameters can be specified, to provide the necessary QoS. Therefore, a state of S_i can be given as a tuple [4]:

$$S_i = (A_j, \delta_t, D_c, Q_{i,c}) \quad (1)$$

This represents that system S can have different numbers of states i and have c subcomponents (e.g., devices, D); δ_t represents the transition time from one state to another state; and A_j shows the traffic characteristics, where J shows the number of packets. $Q_{i,c}$ are the optimal power control parameters of subcomponents c in the state of S_i while providing the required QoS level [4].

2. Efficient and generic energy network efficient architecture

Figure 1 functionally shows efficient and generic network architecture for model of energetic consumption. It is likely that, due to heterogeneity, in services, parameters, process results and even with the network configuration, it may be necessary to treat each of these differently in terms of energy consumption and QoS.

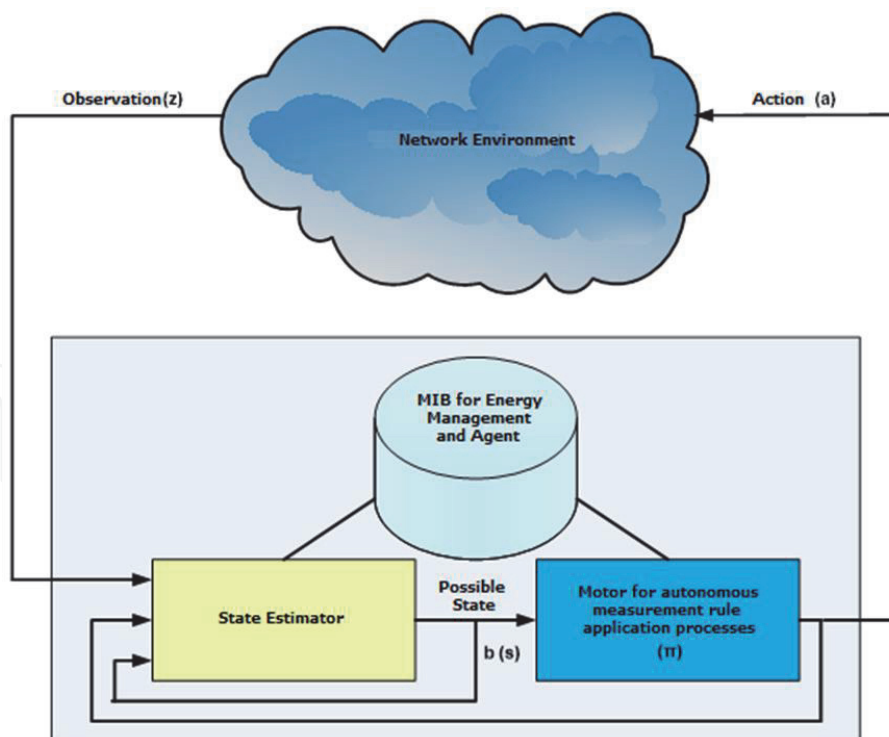

Figure 1.
Generic and autonomous architecture for energy management and QoS.

This type of model describes sequential decision tasks under conditions of uncertainty, due to that the observable system exhibits stochastic behavior. In the case of a power control policy, which calculates an action after each observation, a structural set of measures can be established within a certain period, with which the expected utility, which is maximization, can be considered. With the determination of this, an energy policy can be derived, because it is possible to calculate actions in each time step after extracting information from the respective use of the Management Information Base (MIB).

The application of the Generic Energy Consumption Model starts with the documentation of a case. If the standards are applied, can be created a structure for energy saving that can represent a good percentage of the cost reference, using the MIB model for Power Management. Like an example, the computers and printers in the resting state consume a lot of energy due to the necessary heating that they must periodically have so that they must reach again the ON state. The issue is to use prudential time and parameters so that they remain in a suspended state longer and can still operate satisfactorily when required (see **Figure 2**).

It is expected that the GNSs and production model systems will be observed, incorporating equipment in a critical way to support the operations in IT environment. It is said that criticality is related to the responsibility in the delivery of data, like a function of routers, switches, servers, etc. On the other hand, it is found that there is a network of critical equipment, which has an important role in IT operations, because these are the devices responsible for refrigeration and electrical power supply. These are referenced as generally as Non-Critical Physical Infrastructure (NCPI). In **Figure 3**, the block diagram of the observed and supervised system is presented, composed by an air conditioning unit, which is responsible for refrigeration, and the UPS's, which are coupled with an emergency battery bank.

IT devices are divided into two classes, IT1 that corresponds to telecommunications equipment, such as routers and switches, which are responsible for data transport; and the IT2 unit that corresponds to the data processing equipment and high level services such as servers.

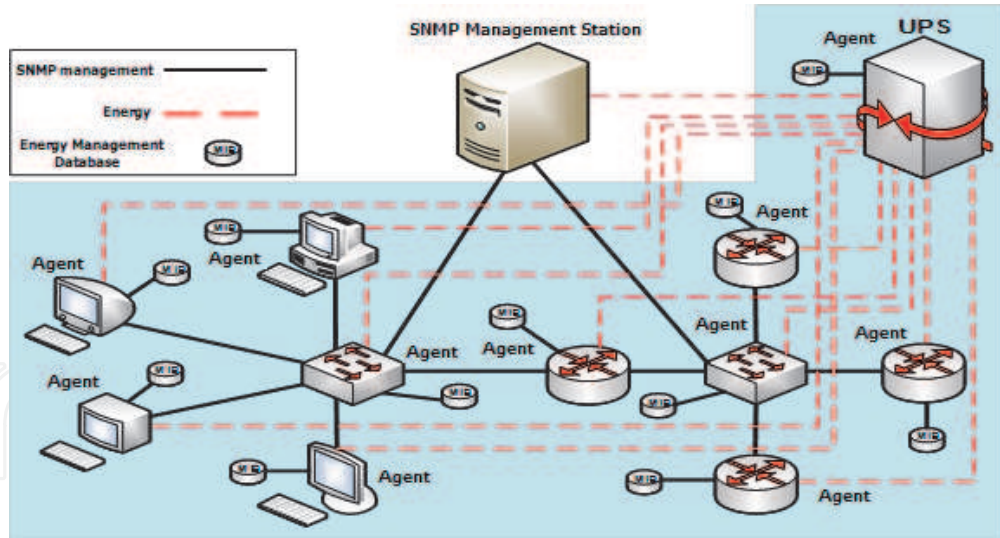

Figure 2. Generic network scheme for energy management.

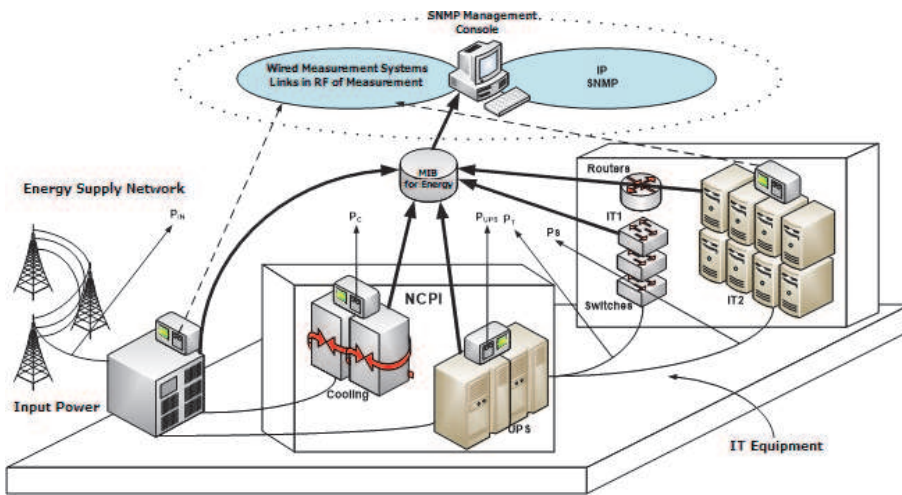

Figure 3. Block diagram of the observed and supervised system of Goods, Networks and Services (GNS).

The total power consumption of the data center is related to the associated power consumed by each unit. The available power of the electrical network (P_{IN} of Figure 3) is a 110 Volt two-phase power installation. The applied power is derived by trajectories, one in series toward the power unit (UPS) and another in parallel toward the cooling infrastructure (P_C). The parallel path feeds the cooling system (air conditioning) which is important for the protection against the heat of a GNS system. The UPS systems that reach the serial power path protect the IT system from failures of supply services, provide the appropriate transition to the emergency generator system, power the IT devices, and provide the necessary energy for data processing and its transport. The power consumption of the telecommunications equipment is represented as P_T and the power consumption of the servers as P_S in Figure 3. The energy efficiency of the data center can be broadly defined as the number of useful calculations divided by the total energy used during a process [3, 5, 6]. To consider energy efficiency, there are two types of indicators, one of them describes the efficiency of NCPI equipment, and the other type defines about useful work related to energy consumption.

The parameter PUE (Power Usage Effectiveness) is defined as the ratio between the total input powers in the facility over the power delivered to IT in the following way:

$$\text{PUE} = \frac{\text{Total Facility Power}}{\text{IT Equipment Power}} = \frac{P_{\text{IN}}}{P_{\text{IT}}}, \text{ for } 1 < \text{PUE} < \infty \quad (2)$$

The metrics of the above equation characterize the performance or power expended in the non-critical components of the data center [3, 4]. A PUE = 2 can be interpreted that for every 1 kWh (kilowatt hour) consumed by the servers, it is necessary to enter 2 kWh (kilowatt hour) to the data center, a 1 kWh (kilowatt hour) is used in the air conditioning supply processes, uninterrupted electric power, auxiliary services such as lighting, security systems, and as a result this generates heating of power plants, ventilation systems and other minor systems.

In the current developments of virtualization systems, it is observed that the IT loads are reduced, leading to having an increasingly higher PUE. If PUE = 1, is the ideal because it indicates that for every 1 kWh (kilowatt hour) that enters the data center, the IT equipment uses 1 kWh (kilowatt hour), it is the best situation regarding the operation of the equipment of an IT system. The closer is the PUE to 1, the more efficient NCPI equipment, which are the IT elements that operate and are classified as a GNS [3].

The metric that models the efficiency of telecommunications equipment (M_T and M_T , IT) is presented in the following equation [2, 7]:

$$M_T = \frac{\sum_{i=1}^k b_i}{E_{\text{IN}}} [\text{Mbits/KWh}] \quad (3)$$

In the equation, k is the number of routers in the GNS and b_i is the total number of bits that leave the same router during the evaluation window [2, 7]. E_{IN} is the total energy consumed by the GNS system during the evaluation window. The evaluation window should be defined in such a way as to allow the capture of the variations in the behavior of the system observed over time. The M_T metric can measure the underutilization of routers or redundant components in the system.

The efficiency of a server is modeled as a function of average CPU utilization [2, 7]. The CPU utilization for each server in the data center is averaged in the T -time evaluation window. The metric used models the Mean Server Productivity (MSP) in relation to the total energy consumption of the system Observed GNS [5, 6], and this is conjugated in the following equation:

$$\text{MSP} = \frac{T \cdot \sum_{i=1}^n \left[U_i \cdot S_i \cdot \left(\frac{CC_i}{CB_i} \right) \right]}{E_{\text{IN}}}, [\text{ssj_ops/KWh}] \quad (4)$$

In the above formula, n is the number of servers and U_i is the average of CPU utilization on the server evaluation window T_i ; and if the power ratio ssj_ops/sec is the 100% utilization per server in the i -th server, CC_i is the nominal clock speed of the server i CPU, CB_i is the CPU clock speed that is used for establish B_i , which is the result of benchmarking the server rate i [2, 7]. The S_i parameter (ssj_ops/sec) describes the operations of the server in one application per second and is included in the list of server specifications. With the use of this metric, it can model the productivity of the GNS systems and the correlation of the actual useful work to the maximum possible work if all the servers ran at 100% utilization.

For example, it is possible to consider these parameters like a reference of eco-efficiency, because these take into account the relationship between the service provided in terms of transmitted bits and the total energy used and consumed by the GNS system represented in joules, affecting the environment with this action. The reference factors taken into account are the amounts of information (which in

this case are data and voice) derived from fixed and mobile networks, the consumption of energy for industrial purposes (control of transmission and climate), and other applications (such as electricity for office use, air conditioning and heating). The objective is extrapolating this model and applying to the case of an ICT environment composed GNS systems [8–10].

3. Energy efficiency and target values of corresponding metrics for a data center

For the selection of best practices, and to improve the current energy efficiency ratio should be defined and associated objective values that must be established on the basis actualized in terms of IT technology and infrastructure [11, 12].

The PUE (Power Usage Effectiveness), already defined, is the recommended metric for the characterization and referencing of the performance efficiency of a data center infrastructure [13–15]. It is recommended to consider the annual energy consumption (kWh) for all types of energy as the unit of measure for the calculation of the PUE. However, a category of entry-level measurement has been included in the recommendations so that operators who do not have the ability to measure consumption to use demand-based power readings and with this can be considered levels of uncertainty [16]. The measurement initiative proposes the application of this energy efficiency index for the data center.

The measurement of this parameter determines four (4) categories for a data center, which is summarized in **Table 1**.

PUE Category 0: This is a calculation based on the demand that represents the maximum load during a measurement period of 12 months. The power is represented by the reading of the demand (KW) of the output of the UPS system (or by the sum of the outputs, if more than one UPS system is installed), measured in the computer equipment during peak usage. The total power of the data center is taken by the meters and is presented as the KW demand in the utility bill. As it is an instantaneous measure, the true impact of IT fluctuations or mechanical loads can be lost. However, consistent measurement can still provide valuable data that can help in the management of energy efficiency [17–19]. The PUE category 0 can only be used for all electrical data centers, that is, it cannot be used for data centers that also use other types of energy (e.g., natural gas, cold water district, etc.) [5, 6, 16].

PUE Category 1: This is a calculation based on consumption. The IT load is represented by a total consumption reading in kWh made during 12 months at the output of the UPS system (or in the sum of the outputs, if more than one UPS system is installed). This is a cumulative measure and requires the use of

Scheme	PUE Category 0*	PUE Category 1	PUE Category 2	PUE Category 3
Location of energy measurement in IT	UPS output	UPS output	PDU output	Server input
Definition of IT energy	Electric demand IT peak	Annual energy in IT	Annual energy in IT	Annual energy in IT
Definition of total energy	IT electric demand peak	Total annual energy	Total annual energy	Total annual energy

*For the PUE Category 0, the measurements are referenced in the electrical demand (KW).

Table 1.
Recommended categories of PUE measurement.

consumption meters in kWh at all measurement points. The total energy is usually obtained from the service company's bills by adding the 12 consecutive monthly readings in kWh, as well as the annual natural gas or other fuel consumption (converted to kWh). This measurement method captures the impact of IT fluctuations and cooling loads and thus provides a more accurate picture of the overall performance of a PUE system of category 0 [16].

PUE Category 2: This is a calculation based on consumption. The IT load is represented in kWh by a measurement by a reading during 12 months taken at the output of a Power Distribution Unit (PDU) that supports the IT loads (or sum of the outputs if more than one PDU has been installed). This is a cumulative measure and requires the use of consumption counters in kWh at all measurement points. The total energy is determined in the same way as Category 1. This measurement method provides additional accuracy of the load reading of IT by eliminating the effects of losses associated with PDU transformers and static switches [16].

PUE Category 3: This is a calculation based on consumption. The IT load is represented by a reading for 12 months and is defined in total kWh taken at the point of connection of the IT devices in the electrical system. This is a cumulative measure and requires the use of kWh consumption meters at all measurement points. The total energy is determined in the same way as category 1. This measurement method provides the highest level of accuracy for the measurement of the IT load reading by eliminating all the effects of the losses associated with the components of electrical and IT distribution that are not related, for example, the fans mounted in the racks, etc., which generates uncertainty [16].

For the normalization process, it is necessary to weight the types of energy based on the energy source. A data center that not only feeds on electricity, should be weighted according to the source of energy. This should represent the total amount of fuel that is required to operate. This should incorporate all the processes of transmission, delivery, and production losses, which allows a complete evaluation of the energy efficiency of a building. It is considered that the weighting factor for the types of energy such as electricity that is 1.0, and for natural gas is 0.35, and for fossil fuels is 0.35 normalized with electricity. Factor each component of the calculation for the PUE needs to be multiplied by the appropriate weighting factor. The weighting is obtained with the following mathematical relationship [20, 21]:

$$\begin{aligned} &\text{Weighted energy for each type of energy} \\ &= (\text{annual energy use} \times \text{energy source weighting factor}) \end{aligned} \quad (5)$$

Because most data centers operate with 100% electric power, the recommended initiative [20] specifies the origin of the energy factors that are weighted with respect to electricity [20, 21]. This indicates that factors are developed to define the origin for each fuel and that are expressing the level of relation with the source factor of the electrical energy. This should indicate that it is agreed that purchases of electricity multiply by a factor of one, and purchases of other fuels are multiplied by the respective factors before being added to the total, and these factors are indicated like references [21].

It is required that all types of energy must be converted, by multiplying the weighting factors, and these must match in the same units before they are added. For that matter, if electricity is in kWh and natural gas is in KBTU, both must be converted to a common unit. Finally, all energy sources for all fuels must be added together [21].

The application of this to a data center has other relationships to measure the efficiency of energy consumption, as shown below:

Data Center infrastructure Effectiveness (DCiE):

$$\begin{aligned} \text{DCiE} &= \frac{1}{\text{PUE}} = \frac{\text{IT Equipment Power}}{\text{Total Facility Power}} \\ &= \frac{\text{Annual ITKWh}}{\text{Total annual KWh}}, \text{ It is the reciprocal of the PUE} \end{aligned} \quad (6)$$

This parameter varies like this,

$$0 \leq \text{DCiE} \leq 1 \quad (7)$$

The best situation is DCiE = 1, and a DCiE = 0 is the worst situation.

The measurements of PUE, and its inverse (the DCiE), determine a reference in the input of energy to IT equipment. If an ideal PUE of 1 is considered, where the total energy that enters the data center is used by the IT equipment, and at the same instance, this equipment is not performing any computer process, can be affirmed that from PUE metric, this is an ideal situation, but in relation to the data center there is no production; for these cases, it is necessary to use other metrics, and the way the IT equipment uses energy should be reviewed.

The frequency of data collection of the PUE variables is determined from the energy consumption of a data center, and this is calculated according to the average of the efficiency of this in the same period. The measurement of the PUE is the average efficiency during a certain period. The operation cycles of the equipment in the data center are about 10 minutes, so the shortest period that gives useful information is 60 minutes. The monthly, weekly, and daily PUE measurement averages are used to determine different operating conditions of a data center, and an annual measurement of the PUE allows to easily relate the energy consumption during the useful life of this. The instantaneous measurements of the PUE must be evaluated in detail, since they are reflecting the specific situation of the operation of the IT equipment and the infrastructure equipment, in order to obtain in best form the efficiency parameters of a data center, and it is necessary to use periods of longer time [5, 6, 22–24].

To deal with this case, it is necessary to start by relating the total energy that enters the data center with respect to the energy used by the IT equipment. The following equation defines the average power [25, 26]:

$$\text{Averagepower} = \frac{1}{N} \sum_1^N \text{Power}(i) \quad (8)$$

The PUE is the point that relates the average power of the data center and the average power of it at any given time, and this same concept relates the average input power to the data center with respect to the average power of the IT equipment [25, 26]. The following equation expresses how to relate the expressed:

$$\text{PUE} = \frac{\text{Average of the Total Power of Entry to the Data Center}}{\text{Average total input power to IT equipment}} \quad (9)$$

The standard deviation is determined by the following equation:

$$\sigma = \sqrt{\frac{1}{N} \sum_1^N (\text{Power}(i) - \text{Average Power})^2} \quad (10)$$

As has been mentioned, the value of the PUE is determinate in ranges of infinity to one, the latter indicates to have an efficiency of 100% [25, 26]. If you get information from the behavior of a data center, this should tell what kind of behavior shows this system GNS, and if you have behaviors very close to a PUE = 3 or greater, these results are inefficient. The organization Green Grid establishes the allocation to each value of PUE and DCiE and relates the level of efficiency [27].

If it is necessary to make comparisons of the PUE of different data centers, it is essential to have enough information that allows to make an accurate and valid comparability. This information is supposed to compose it [22, 23]:

- Definition of the PUE measurement period: that can be yearly, monthly, daily, or per hour.
- Specification of outside temperature conditions, land area where it is located (temperate, tropical, and poles). Altitude above sea level. The climatic conditions maintain continual variations, since if it is the region of Colombia, one can speak of the model tropicalized.
- Determination of the percentage of the data center's computer load. This varies in the hours of the day, as well as every week and every month.

The loads of the GNSs of an IT system vary during a day, changing the value of the efficiency according to the time that is measured. On weekends and holidays, IT charges vary with respect to functional days, in which the efficiency varies according to the day on which it is observed. If the point of operation is determined, relating the energy efficiency according to the IT load, a data center would allow to evaluate if it is oversized in its design or has a design adjusted to the load of IT equipment.

A data center would have affected its operation, and therefore its energy efficiency is due to the combined effect of temperature, external humidity, and the computational load. The variations of the external temperature combined with the variation of the computational load determine the performance and the energy efficiency [23, 24]. This specific modeling helps to measure the electrical efficiency for a data center, where the demand vs. the losses of the energy efficiency are related, and shows how the total energy consumption is determined by the atmospheric conditions exteriors (temperature and humidity) and the load of IT

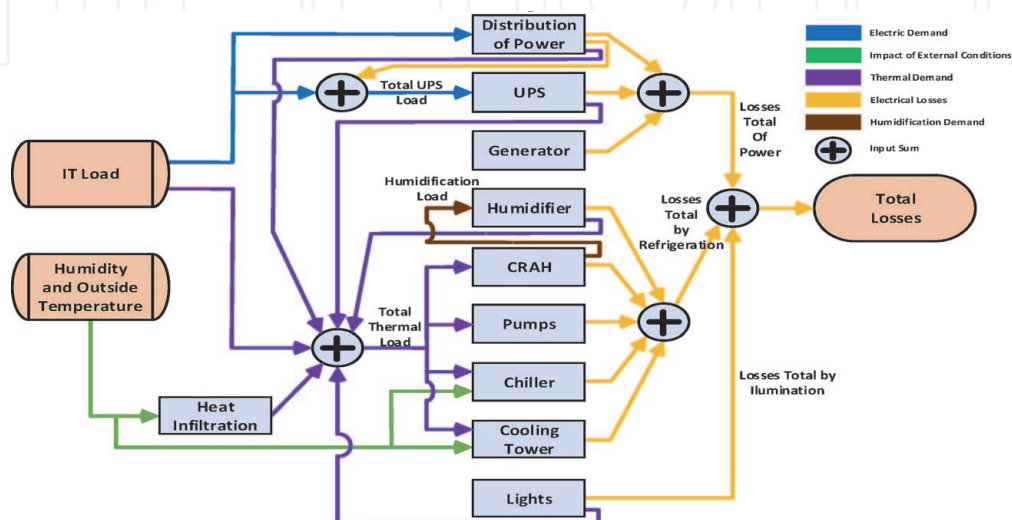

Figure 4. Electrical efficiency measurement model for a data center. Demand vs. energy efficiency losses.

equipment; this model was obtained with SDL (Specification Description Language), see **Figure 4**.

This model is like the functional noise model in telecommunications, and in this, it determines that total electrical losses are due to the sum of the electrical loss due to power, cooling, and lighting. The losses due to the electricity supply are the sum of the loss by the distribution, by UPS, and the other systems. The cooling system losses are in the humidifiers, Computer Room Air Handler (CRAH), pumps, ice water plant, and cooling tower. The computational charge directly impacts the power distribution and UPS system, as well as the thermal load (heat dissipated by IT equipment). External temperature and relative humidity directly impact with flows heat to the cooling systems [5, 6].

4. CUE (carbon usage effectiveness)

To estimate the energy consumption of the data centers and thus to determine the carbon footprint, the CUE is considered, which allows to determine its effect on the environment. In order to know the effect or impact that the environment generates for the energy consumption of the data centers, it must first determine this and then convert such information into carbon emissions. The carbon footprint of a data center is directly proportional to the power consumption. In the definition of this parameter, there are three variables that are considered and give a greater impact on the energy consumption, these are:

- Location, geographical location, and altitude above sea level.
- The IT equipment load (computer load).
- The energy efficiency of the infrastructure and IT equipment.

In the case of the measurement of this effect, this ratio converted to metric evaluates the emissions of CO₂ (GHG greenhouse gas) associated with energy losses in a data center. The technology with which the electricity is generated using a data center defines the emissions of CO₂ produced per kWh consumed and its expression is the term KgCO₂/kWh. If a certain consumption environment requires various forms of energy generation to meet the demand (as a hydroelectric, wind, nuclear, and thermal generation that consumes fossil fuels such as coal and natural gas), then that generation it considers a composition of energetic factors more extensive and likewise varies according to the state of the demand.

In peak consumption schedules, the result of the generation by energy composition can be very polluting, because this peak demand must be covered by the generation of energies that compromise fossil fuels. Carbon footprint quantifies the amount of emissions, expressed in tones of CO₂ equivalent, which are released into the atmosphere because of the development of any activity. Emissions (GHG) are divided into:

- **Direct emissions:** those that are emitted from sources that are controlled.
- **Indirect emissions:** those that are the result of the activities, but that are emitted from sources that are not controlled.

The emissions typically come from the following source categories:

- **Fixed combustion:** combustion of fuels in stationary or fixed equipment.

- **Mobile combustion:** combustion of fuels in means of transport.
- **Process emissions:** physical or chemical process emissions.
- **Fugitive emissions:** intentional and unintentional releases.

5. Measuring the green energy coefficient (GEC)

The green energy coefficient (GEC) is a metric that defines the percentage of energy that is green. To define this, there is complexity, because there are differences in the part of determination as to what is considered as the different types of renewable/green energies in reference to the region in question. This seeks to recognize as green energy anyone who is used in a data center that has a legal right defined in environmental attributes for renewable energy generation. Such legal rights are regionally recognized as certificates of green energy, renewable energy, and other similar products, which are issued by several recognized authorities who deliver the equivalent of a certificate of energy green [20, 28, 29]. Given this definition of green energy, GEC is calculated as follows:

$$\text{GEC} = \frac{\text{Green Energy used for Data Center}}{\text{Total Power Source of Data Center}} \quad (11)$$

The GEC is defined by determining a maximum value of 1.0, which indicates 100% of the total energy used by the data center, and this defines the green energy [29]. Please note that for the purposes of this calculation, the total energy source consumed in the data center is identical to the PUE numerator. As with the PUE, all the energy will be notified using the same units, and the recommended unit of measurement will be kWh. The standard thermal conversion factors are used to convert to kWh are (for example, 1 kWh = 3,412 KBTU; 1 GJ = 278 kWh). Finally, because the definition of green energy is based on the legal ownership of the rights of environmental benefits, it is important to clarify that the location of the energy source does not change the calculation of GEC. For example, a data center can have a solar panel on the roof to generate power; if you sell the green energy certificates associated with this power, then you cannot be covered by the concept that electricity is green. It should be noted that this standard is measurable if it has a green power supply scheme and that helps cogeneration. In the case of the local development environment, these models are not counted.

The data center can be certified by the correct use of power, and these green energy certificates only can be achieved with a consumption of energy with a GEC = 1.00. For example, if it was considered an energy power of 130 GWh that were generated by renewable sources and this is applied to a data center, it could sell 30 GWh worth of green energy certificates without affecting the GEC of 1.00, the main idea is to have self-sufficiency, and to have an environment of electrical consumption that reverts in some way to the primary energy system, and it is to be expected that this is a considerable proportion of electrical energy, so that this leads to achieving a green certification for the management of consumption energetic [22].

6. Conclusions

- This chapter shows a model to measure energy consumption and therefore focuses on improving the energy efficiency of data centers that support the

execution of services. To achieve our target, it has been used eco-Indicators in a green computing environment and it has achieved minimizing the environment impact in high percentage, with this initiative.

- The PUE/DCE are industry standards, the determination of the energy efficiency of a data center will allow comparing the degree of efficiency of an observed objective installation with other data centers around the world. It also helps to establish a point of reference that allows to control, inform, and improve continuously, in other words, to make efficient management of the resource.
- It is concluded that it is very important to develop some techniques to be used as an alternative to cloud computing in an ecological way. The following is to start the search for active migration techniques that are determined at the threshold of the infrastructures to be controlled, taking into account that it is likely that a number of necessary migrations will have to be controlled and therefore this will determine an energy consumption, that sometimes it will be expensive to use, which may affect the QoS. This involves using the help of an integrated middleware with Green Cloud Architecture, and this helps control energy consumption, but again this intrinsically adds the additional cost of middleware in the cloud computing architecture.

Author details

Jesus Hamilton Ortiz^{1*}, Fernando Velez Varela² and Bazil Taha Ahmed³

1 CloseMobile R&D, Spain

2 Universidad Santiago de Cali, Colombia

3 Universidad Autonoma de Madrid, Madrid, Spain

*Address all correspondence to: jesushamilton.ortiz@gmail.com

IntechOpen

© 2020 The Author(s). Licensee IntechOpen. This chapter is distributed under the terms of the Creative Commons Attribution License (<http://creativecommons.org/licenses/by/3.0>), which permits unrestricted use, distribution, and reproduction in any medium, provided the original work is properly cited. 

References

- [1] Arciniegas H, José L, Velez Varela F. Architectures of Network Management and Telecommunications Services. University Libre Cali; 2008
- [2] Jain V, Parr GP, Bustard DW, Morrow PJ. Deriving to generic energy consumption model for network enabled devices. In: India-UK Advanced Technology Center of Excellence in Next Generation Networks, Systems and Services School of Computing and Information Engineering. Coleraine, UK: IEEE, School of Computing and Information Engineering, University of Ulster; 2010
- [3] The Green Grid. Proxy proposals for measuring Data Center productivity. White Paper # 13, GreenGrid Web Site. 2008. Available from: <http://www.thegreengrid.org/>
- [4] Jain V, Parr GP, Bustard DW, Morrow PJ. Deriving a Generic Energy Consumption Model for Network Enabled Devices. 2010. Available from: https://www.academia.edu/32194810/Deriving_a_generic_energy_consumption_model_for_network_enabled_devices
- [5] ITU-T Recommendation L1300: Best practices for green data centres; 2014
- [6] ITU-T Recommendation L1301: Minimum data set and communication interface requirements for data center energy management; 2015
- [7] Stavropoulos TG, Koutitas G, Vrakas D, Kontopoulos E, Vlahavas I. A smart university platform for building energy monitoring and savings. *Journal of Ambient Intelligence and Smart Environments*. 2016;**8**:301-323. DOI: 10.3233/AIS-160375. Available from: <http://lpiis.csd.auth.gr/publications/thanosJAISE2015.pdf>
- [8] ITU-T Recommendation L1310: Energy efficiency metrics and measurement methods for telecommunication equipment; 2014
- [9] ITU-T Recommendation L1320: Energy efficiency metrics and measurement for power and cooling equipment for telecommunications and data centers; 2014
- [10] ITU-T Recommendation L1320: Reference operational model and interface for improving energy efficiency of ICT network hosts; 2015
- [11] Datacenter Consultores. Energy Efficiency Metrics for Data Center According to The Green Grid: PUE and DCiE; 2010
- [12] Jaureguialzo E. PUE: Green grid metric for the evaluation of energy efficiency in CPD. In: Measurement Method by Means of the Power Demand. Madrid: The Green Grid; 2012
- [13] Chromalox Precision Heat and Control. Determination of Energy Requirements for Air and Gas Heating; 2010
- [14] Dunlap K. Auditing of Cooling Schemes to Identify Possible Cooling Problems in Data Centers; 2008
- [15] Herrero Y, Cembranos F, Pascual M. Change the Glasses to Look at the World. Madrid: Ecologists in Action; 2011
- [16] European Telecommunications Networks Operator's Association - ETNO Project, Energy Task Team; First Annual Report; 2005–2007. London; 2008
- [17] ITU-T Recommendation L1400: Overview and general principles of methodologies for assessing the environmental impact of information and communication technologies; 2011

- [18] ITU-T Recommendation L1410: Methodology for environmental impact assessment of information and communication technologies goods, networks and services; 2012
- [19] ITU-T Recommendation L1420: Methodology for energy consumption and greenhouse gas emissions impact assessment of information and communication technologies in organizations; 2012
- [20] Green Grid Project; Recommendations for Measuring and Reporting Overall Data Center Efficiency; Version 1 – Measuring PUE at Dedicated Data Centers; 2010
- [21] Green Grid Project. PUE™: A comprehensive examination of the metric. 2012. Available from: https://datacenters.lbl.gov/sites/all/files/WP49-PUE%20A%20Comprehensive%20Examination%20of%20the%20Metric_v6.pdf
- [22] Green Grid Project; Harmonizing Global Metrics for Data Center Energy Efficiency, Global Taskforce Reaches Agreement Regarding Data Center Productivity; 2011
- [23] Rasmussen N. Implementation of data centers with high energy efficiency. Internal report No. 114 APC; 2006
- [24] Rasmussen N. Imputation of Energy Costs and Carbon Emissions from a Data Center to Users of Computer Services; 2012
- [25] Rasmussen N. Measurement of Electrical Efficiency for Data Centers; 2012
- [26] Dayarathna M, Wen Y, Fan R. Data center energy consumption modeling: A survey. IEEE Communication Surveys and Tutorials. 2016;18:1. DOI: 10.1109/COMST.2015.2481183. Available from: <https://ieeexplore.ieee.org/stamp/stamp.jsp?arnumber=7279063>
- [27] Tipley R. PUE Scalability Metric and Statistical Analyzes; 2009
- [28] ISO 14040 series of standards. Standards and Technical Reports for Environmental Management - Life Cycle Analysis
- [29] Green Grid Project; Harmonizing Global Metrics for Data Center Energy Efficiency, Global Taskforce Reaches Agreement on Measurement Protocols for GEC, ERF, and CUE – Continues Discussion of Additional Energy Efficiency Metrics; 2012