

# We are IntechOpen, the world's leading publisher of Open Access books Built by scientists, for scientists

4,800

Open access books available

122,000

International authors and editors

135M

Downloads

Our authors are among the

154

Countries delivered to

TOP 1%

most cited scientists

12.2%

Contributors from top 500 universities



WEB OF SCIENCE™

Selection of our books indexed in the Book Citation Index  
in Web of Science™ Core Collection (BKCI)

Interested in publishing with us?  
Contact [book.department@intechopen.com](mailto:book.department@intechopen.com)

Numbers displayed above are based on latest data collected.  
For more information visit [www.intechopen.com](http://www.intechopen.com)



# Feasibility Analysis of Solar Power for the Safety of Fast Reactors during Beyond Design Basis Events

*Kudiyarasan Swamynathan, P. Sivakumar and K. Karthikeyan*

## Abstract

This chapter presents a new design that unites the favorable technical and ecological characteristics of the solar and nuclear power plants. The current designs of nuclear reactors promise integral configuration of the primary coolant loop, secondary coolant loop, and a number of passive safety functions and overall simplification of the reactor. The present nuclear reactor design emphasizes on the safety of the reactor core at all times, i.e., controlling the reactor, cooling the reactor core, and maintaining containment. In case of non-availability of standby emergency DGs during beyond design basis event like Fukushima incident, etc., leading to extended station blackout conditions, the passive decay heat removal system will be affected. Hence, additional DGs have been made as a mandatory requirement in nuclear power plants. In case the ADG could not be mobilized during BDBE, an additional backup power source not affected by BDBE is appreciated. Hence in addition to the diesel power sources (EDG and ADG), a new design was developed for integration of diesel power with solar power. The hybrid system was designed to improve the reliability and availability of passive heat removal system, to ensure a reliable supply without interruption, and to improve the overall system reliability (by the integration with the battery bank). This hybrid power also gives the redundant power supply to the safety critical systems. This chapter also features a detailed reliability analysis carried out for power supplies to the safety critical loads. In addition a comparison was made between PV/diesel/battery with diesel/battery. These new hybrid systems conserves diesel fuel and reduce CO<sub>2</sub> as well as particulate emissions that are harmful to environment health. Integration of solar power to the existing battery power will increase the reliability and extended availability of the system and thereby ensures safety of the plant during crisis/calamities.

**Keywords:** solar power, nuclear power, diesel power, GRID power, economical, PV cell with battery, reliable power, hybrid solution

## 1. Introduction

Energy security is a goal that many countries are pursuing to ensure that their economies function without interruption and that their people have access to adequate, reliable and affordable supplies of modern and clean energy [1–3]. It is a pressing concern because the demand for energy is growing rapidly due to robust

economic expansion, population growth, new uses of energy and income growth and yet the supplies of energy resources required to power these needs are finite and in most cases non-renewable [4–9]. Furthermore, the production, transportation and utilization of energy are a major source of greenhouse gases that cause global warming and climate change [10, 11].

BharatiyaNabhikiyaVidyut Nigam Limited (BHAVINI) is currently in the advanced stage of commissioning of the 500 MWe PFBR Prototype Fast Breeder Reactor (PFBR) at Kalpakkam. The PFBR is the forerunner of the future Fast Breeder Reactors which provides energy security to the country. The design of PFBR is indigenously developed by Indira Gandhi Center for Atomic Research (IGCAR) located at Kalpakkam.

PFBR uses sodium as a coolant to transfer heat from the reactor core to the water for steam production. PFBR is a pool type reactor having two loops of sodium viz. Primary and Secondary sodium loops. The entire bulk of the primary sodium is contained in a single large vessel called the main vessel. Two Primary Sodium Pumps (PSPs) circulates sodium in the main vessel through the reactor core. An inner vessel separates hot and cold pools of sodium. The heat transfers from primary sodium to secondary sodium through 4 Intermediate Heat Exchangers (IHXs) and then from secondary sodium to water for steam production through 8 Steam Generators (SGs). The liquid sodium being highly reactive with air, it requires additional safety measures to isolate the coolant from atmosphere. Above the free level of sodium, in main vessel argon gas is provided.

During full power operation of the reactor, sodium is drawn from the cold pool by 2 mechanical centrifugal PSPs working in parallel and is delivered to the grid plate through 4 pipes at 670 K (397°C). From there, it passes through the core and picks up the heat. Then the sodium at 820 K (547°C) flows into hot pool and enters the inlet windows of IHXs. The flow through IHX is due to sodium level difference of 1.5 m between hot and cold pool generated by main pump. It passes through the shell side of the IHX and transfers heat to the secondary sodium which passes through the tube side. The primary sodium leaves the IHX through the outlet windows and returns to the cold pool. The schematic of the reactor system is shown in **Figure 1** [12].

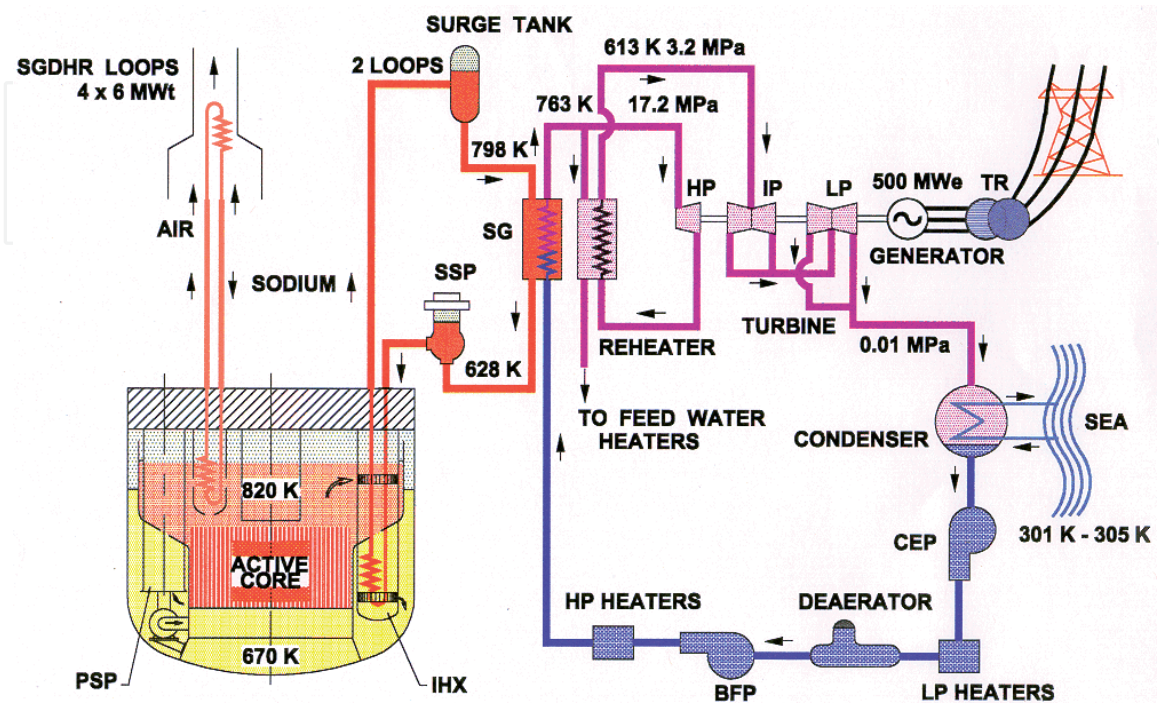

**Figure 1.**  
Schematic of the reactor system.

Variable speed AC drives are provided for the two primary and two secondary sodium pumps. The supply to these drives systems for normal operation is fed from the Class IV (Grid) normal AC power supply. When the normal AC power supply fails, the flow requirement during the initial coast down period is provided by the energy stored in the flywheels of the motor for all the four sodium pumps.

Additionally, an AC pony motor (powered by UPS supply) with over-run mechanical clutch is provided over each PSPs to provide forced core cooling during loss of off-site power supply and station black out conditions for 4 h. The over-run mechanical clutch provided disconnects the pony motor from the main drive motor when the speed of the main drive motor is greater than 17% of the rated speed. On loss of Class IV supply, PSPs coast down to 20% speed from 100% speed due to flywheel action in 40 sec and the speed reduces to 15% in 50 sec. The PSPs are provided with hydrostatic bearings and the PSPs are required to be operated at least at 15% speed to prevent damage to bearing [13]. PSPs are not envisaged to be started from rest using Emergency Diesel Generator (EDG) sets due to provisions of pony motor and the pump running under loss of offsite supply.

The power supply to the pony motor is fed from the class III 415 V bus and from a dedicated battery bank along with the associated inverter. The Pony motor is designed to drive the pump at 17% of the rated speed when the power supply to the PSP AC drive motor fails. The dedicated battery bank is designed to supply power to start the pony motor from rest and cater the load of pump lubrication oil system for 4 h. The battery is sized such that the end cell voltage is 1.85 V at the end of 4 h of operation of the pony motor. This battery is charged by battery charger fed from the Class III emergency bus power supply. Each Pony motor is provided with an inverter to convert the DC voltage into AC voltage.

No break AC and DC system power supply derived from Class III Busses. During normal operating condition, the offsite class-IV power supply is extended to battery Class I as well as UPS class-II system requirement through the Class III Emergency bus. However, during loss of offsite class-IV system, the power supply will be derived from class-III system through Emergency DGs. On failure of the offsite and onsite Emergency DG power supply, this class-I and II system will continue to feed its load from the stored energy in battery banks to meet the emergency requirement. During this condition, battery will feed the power supply requirement for bringing the reactor to safe shutdown state, ensuring decay heat removal with pony motor, passive heat removal system, etc., and also monitoring vital core parameters up to 4 h.

A detailed analysis of PFBR after Fukushima incident recommended that during a natural calamity of such higher magnitude, the existing arrangement may not be sufficient to meet the emergency requirement [14]. Hence, additional DGs/mobile DGs were provided to meet the emergency requirement. The reliability of the system will increase further with this provision. A detailed study indicated that the above system may also become insufficient when Additional Diesel Generators (ADG) could not be moved to the desired location as the access roads may not be conducive during floods or tsunami incident.

In view of the above, solar power can also be integrated with the existing ADG to improve the reliability of the system. The hybrid solar and diesel power will improve the reliability of the safety and safety critical systems on BDBE and ensures availability of these systems to mitigate the consequences of such events. These new hybrid systems conserves diesel fuel and reduce CO<sub>2</sub> as well as particulate emissions that are harmful to environment health. This paper also features a detailed analysis of the energy flows through the system. In addition a comparison was made between PV/diesel/battery with diesel/battery and the result shows that the capital cost of a PV/diesel hybrid solution with batteries is nearly three times higher than that of a diesel and battery combination.

## 2. Existing electrical configuration

Electrical system is one of the major sub-systems of PFBR which comprises normal and emergency power supply systems. Normal power supply is Generator power supply during plant operation and power supply from the grid during Startup of the plant or in case of Generator trip event. Emergency power supply is the onsite power supply to the safety related systems which supports the loads related to plant safe shutdown and to remove the decay heat. The emergency power supply system includes Class III power supply back up provided by Emergency DGs, Class II No break AC power supply and Class I No break DC power supply. In case of normal power supply failure, UPS supplies power to Class II system loads. Rectifier/Charger with battery backup feeds the loads pertaining to Class I system until Emergency DG power supply is restored [15]. The moment Emergency DG incomer closes, these loads are fed by diesel power supply and the remaining class III safety loads are restored according to the priority. The existing normal and backup sources are shown in **Figure 2**.

Station blackout occurs when the off-site power supply fails and the all four Emergency DGs (on-site power supply) could not be deployed. Under a station blackout conditions, the Class I and Class II power supplies should be available for a minimum period of 30 min to meet the rated loads and to supply the essential loads important to the safety and controls of the reactor for the station blackout duration of 4 h. The Class I and Class II system batteries form the source of power during the station blackout condition.

Following the occurrence of the station blackout, under the reactor shut down condition, the decay heat from the core is removed by the safety-grade decay heat removal circuits. In order to help the removal of the decay heat AC Pony motors are provided for the primary sodium pumps and they are fed from their dedicated batteries and the associated inverters. Detailed analysis has been carried out for the station blackout duration. The probability of occurrence of Station Blackout (SBO) with duration of 4 h is  $10^{-4}$  per reactor year and the probability of occurrence of an SBO with duration of 14 h is  $10^{-6}$  per reactor year. The estimated unavailability of class III power system is  $2.4 \times 10^{-3}$  per reactor year for 2 out of 4 Emergency DG systems and  $6.8 \times 10^{-4}$  per reactor year for 1 out of 4 Emergency DG systems. The dedicated batteries supplying the AC pony motor are rated for a minimum of 4 h duration so that the clad temperature limit is not exceeded. Natural convection is adequate to limit the clad temperature during SBO beyond 4 h. The power supply

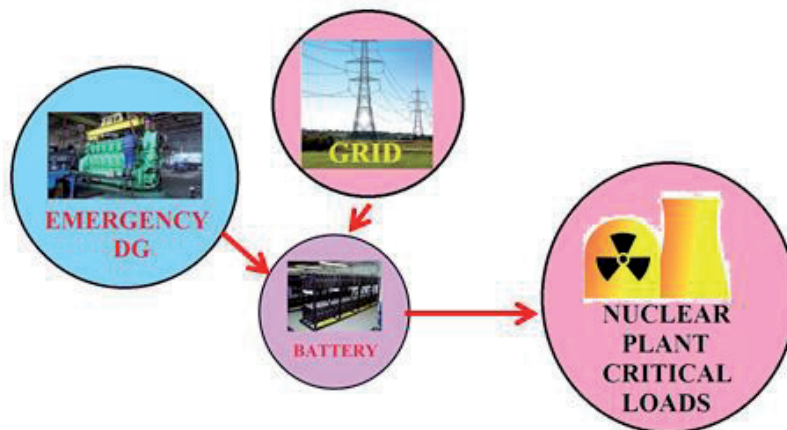

**Figure 2.**  
Existing normal and backup sources for critical loads.

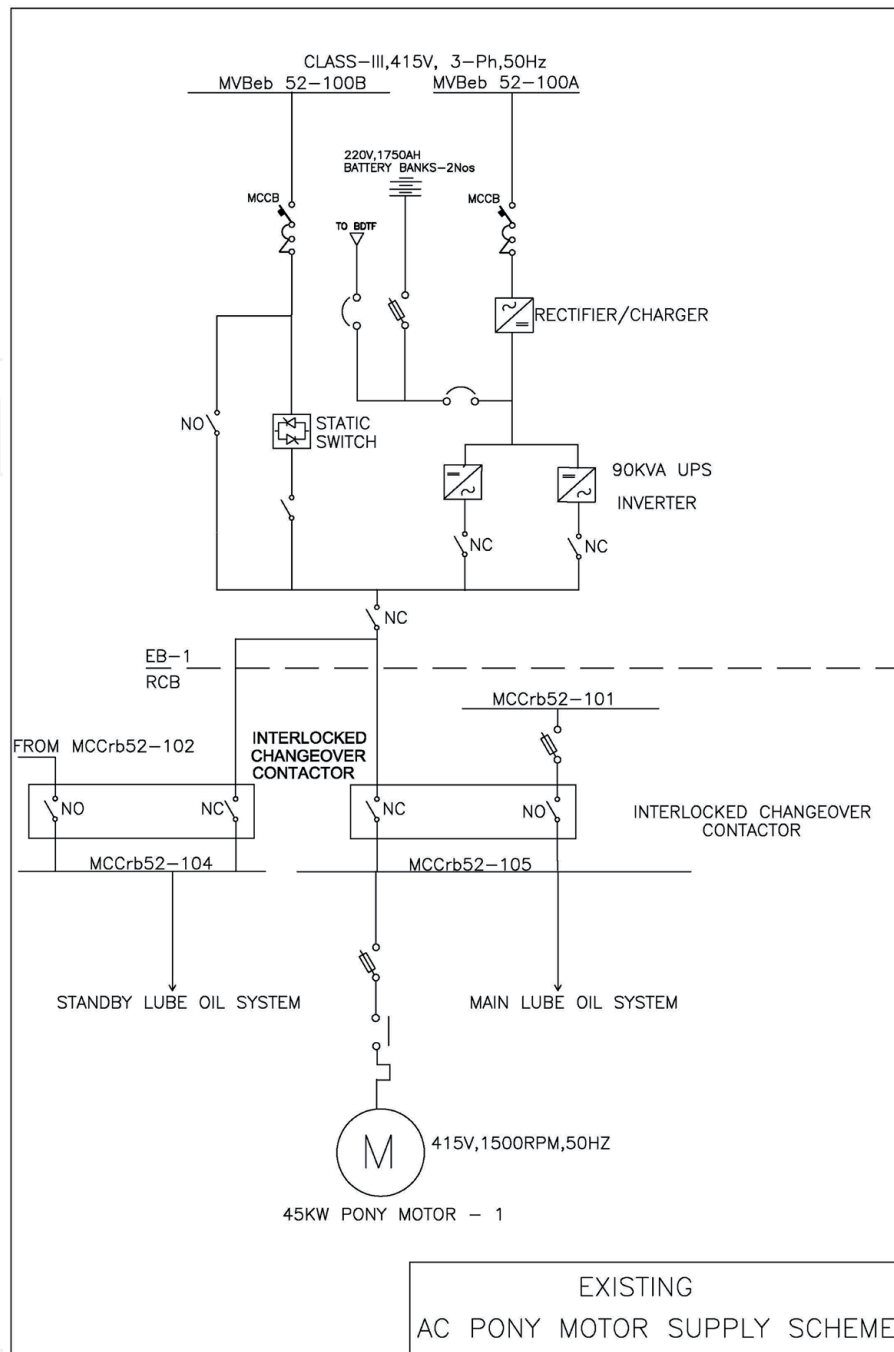

**Figure 3.**  
 Existing AC PONY motor power supply schematic.

to the pony motor is fed from two class III 415 V bus and from a dedicated battery bank along with the associated inverter. One class-III power supply is connected to the charger. Another one is connected to the bypass through static switch. In case the rectifier/charger unit is having internal problem, then the second source will feed the power supply to the pony motor [16].

Solid state converters and stationary lead acid batteries are used in the power supply circuit intended to supply power to the AC pony motor and the pump auxiliaries for the lubrication oil system. Each Pony motor is provided with an inverter to convert the DC voltage into AC voltage [17].

Further, power supply to the each main oil and standby lube oil for pony motor is received from one dedicated class-III Motor Control Center (MCC) panel and one standby power supply from the dedicated battery system as show in **Figure 3** [18].

### 3. Proposed electrical configuration

The above arrangement is generally available in existing nuclear power plants. In case of non-availability of Emergency DGs during BDBE (In view of Fukushima incident) leading to extended station blackout conditions, a safety up-gradation of emergency power supply is essential. To meet the requirement an additional two numbers of 500 kVA rating tyre mounted portable ADGs are to be moved to site from the stored location to ensure availability of power to PSP pony motor (45 kW) and monitoring, removal of decay heat from the reactor, Motors associated with Control and Safety Rod Drive Mechanism (CSRDM), Diverse Safety Rod Drive Mechanism (DSRDM) lighting in the main control room, back up control room, switchyard control room and the DG buildings.

The ADGs are planned to be located away from the main plant area, in Emergency Control Center which will be a common facility at Kalpakkam equipped to deal all types of accident/crises/emergencies. These ADGs will be mounted over the seismic pads. When requirement arises, ADGs will be brought to plant area nearby Electrical Building. The ADG is always kept on the Tyre mounted truck at an elevation which is 3.154 m above plant design basis flood level. The tyres will be raised above floor by mechanical jacks during operation. Considering the condition of access route post-accident/natural calamity this ADG will be brought into the plant area from its storage location with the help of Tractor/Hydra/Crane/JCB, etc., within the station blackout period, i.e., 4 h. ADG oil storage tanks are designed to store the fuel for 8 h of continuous operation. This ADG will feed the power to the existing 415 V busses. The power supply provision between the ADG Panel to the existing 415 V busses are permanently made available. Cables are to be laid from ADG and ADG panel when the ADGs are moved. Considering the design safety limits for driver fuel clad hotspot temperature, adequate capacity battery backup is provided to ensure effective decay heat removal [19]. The minimum coping time of 4 h is recommended considering of the combination of events. The minimum required lighting for safe movement of ADGs to locations near Electrical Building like alternate Street lights are temporary powered. The portable battery operated torches will also be pressed into service.

A solar power unit having PV cells mounted at the top of Electrical building-1, Electrical Building-2 and Control building is connected to the Pony motor Battery

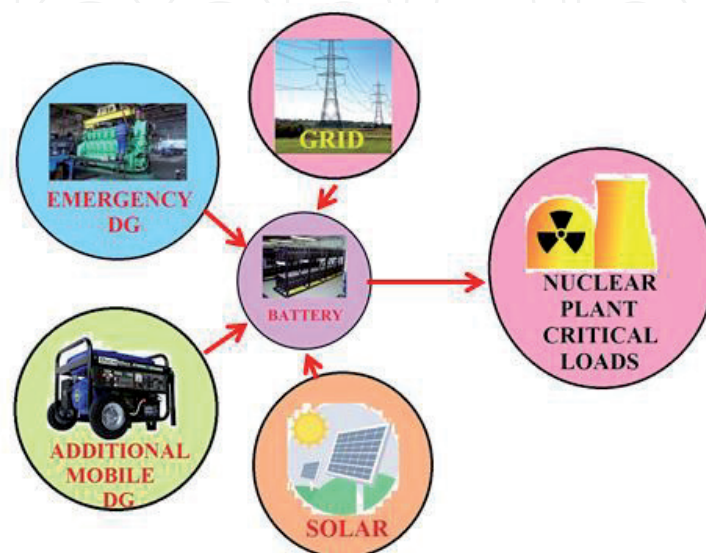

**Figure 4.**  
*Proposed backup and Normal sources for critical loads.*

banks through a DC-DC Converter with surge protective devices [20]. The DC-DC converter is equipped with in an Auto synchronization facility which is provided for pumping power during day time/when solar radiation is available [21]. The synchronization is done at DC side instead of connecting at the incomer AC supply side by converting PV-DC supply to AC supply by an additional Inverter [22]. This arrangement complicates the system and an extra device reduces the reliability. This arrangement gives extra reliable power supply to the decay heat removal mission. The proposed additional mobile DGs (ADG) and Solar with the existing power sources are shown in **Figures 4 and 5**.

In addition to existing, two more redundant power supply provision are made to increase the reliability of the system. The ADGs power supply fed to the existing 415 V class-III bus through Switch Fuse Unit (SFU). A Solar power is also

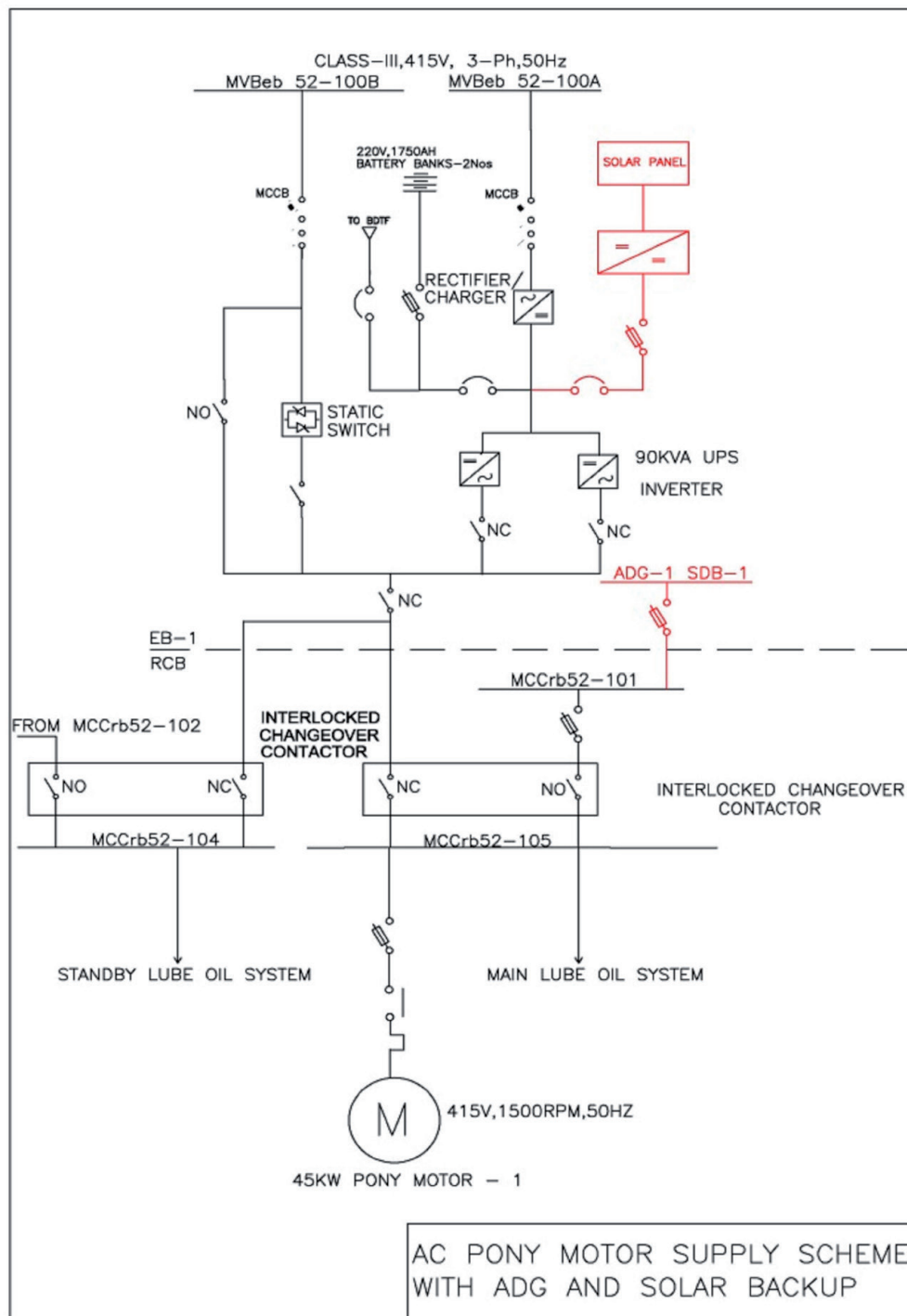

**Figure 5.**  
 Proposed AC PONY motor power supply schematic.



introduced in the proposed power supply schematic of pony motor. The solar power is directly connected to the existing battery system to charge the battery through SFU and Miniature Circuit Breaker (MCB) [23]. The solar power will directly charge the battery as well as deliver the load through the inverter. The proposed electrical power schematic is shown in **Figure 5**.

#### 4. Design basis external events of nuclear reactor

Nuclear reactors are prone to get affected due to various events as indicated in the **Figure 6**. The major event to affect the reactor is power failure, earthquake, flood and lightning [24]. During all the events power failure is one of the main causes to affect the reactor safety system. Hence to overcome the above issues in the modern world, integrated power supply to be arranged for reactor cooling systems [25]. In line with the above, here the solar power is integrated along with the existing additional DGs to increase the reliability of the nuclear safety [26].

In the existing system, during a BDBE, the Emergency Diesel Generator may fail and the ADGs will be lined up to feed power supply to the pony motors. If ADGs could not be shifted to the desired location within 4 h, the dedicated battery banks gets drained and there is no further backup for reactor core cooling. Hence, the proposed system will continue to feed power supply to the battery banks and the reactor safety will be ensured during beyond design basis event also.

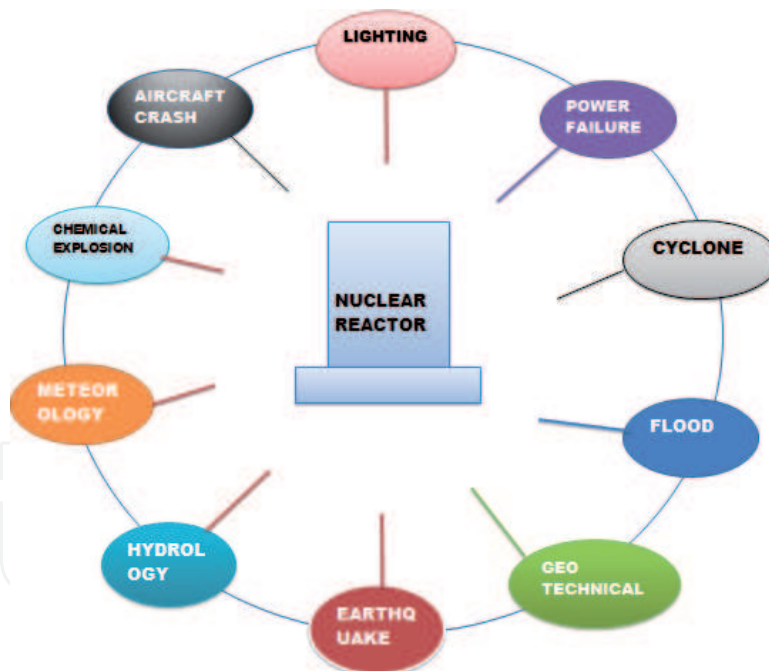
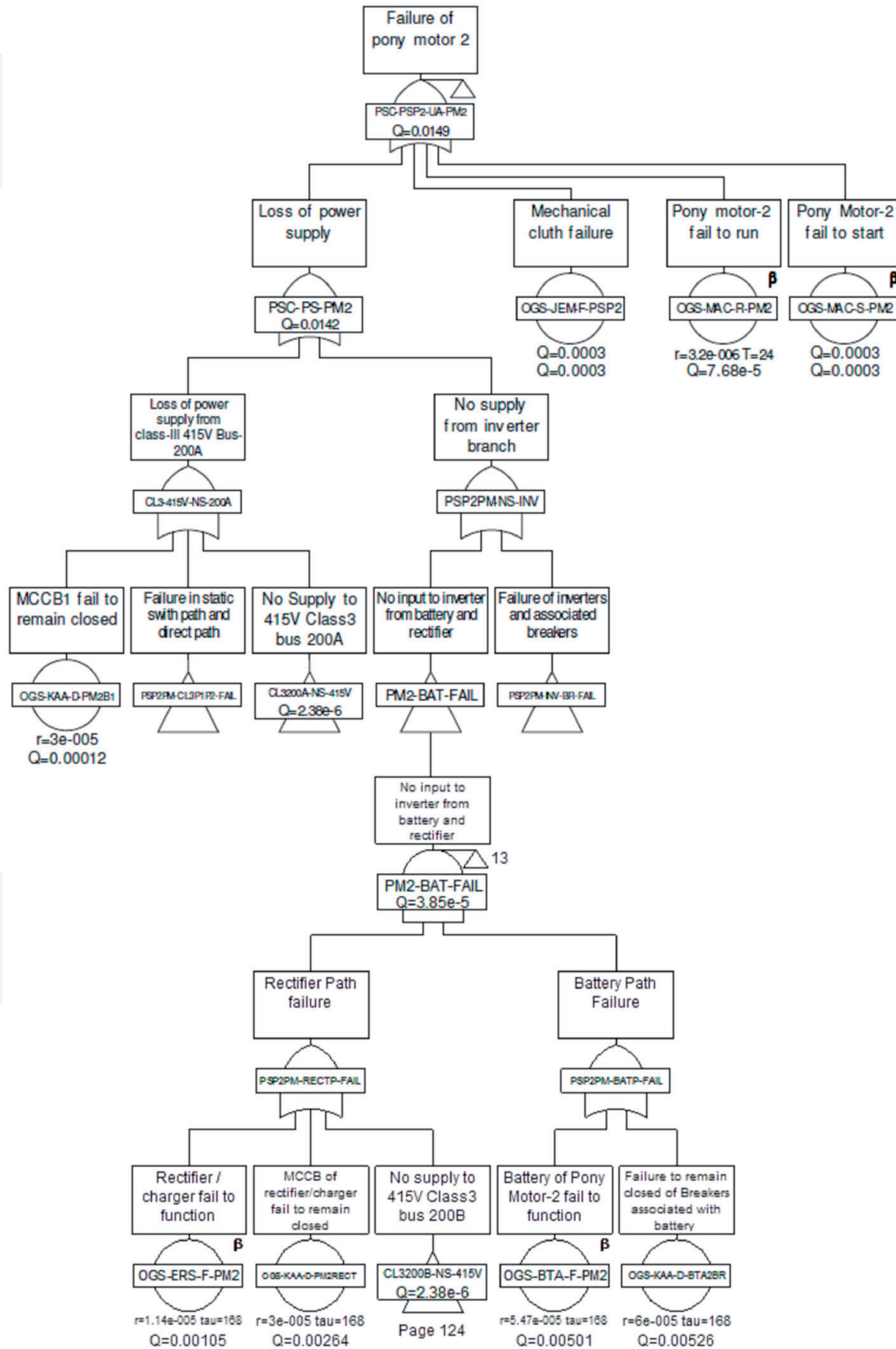

**Figure 6.**  
*Design basis external events of nuclear reactor.*

#### 5. Reliability of existing power supply scheme

Pony motor is supplied with 415 V dedicated 90 kVA UPS and also a Class III 415 V supply from emergency bus as seen earlier. Failure rate of the Pony Motor on demand has been estimated by computational methods using software called ISOGRAPH Reliability Work Bench 2008. The failure of each power supply train and its probable causes have been analyzed separately to arrive at the overall failure

rate of pony motor. In the existing scheme, the UPS failure includes failure of rectifier path and battery path. With two sources of power supply failure to UPS taken for the analysis, the failure rate of Pony Motor UPS is found to be  $3.85 \times 10^{-5}$  [27]. This brings the overall failure rate of the Pony motor to 0.0149 as shown in **Figure 7** [28].



**Figure 7.**  
 Fault tree for failure of pony motor with existing power supply scheme.

## 6. Reliability of proposed power supply scheme

With inclusion of solar power in the existing scheme, the failure rate has been analyzed [29]. The failure rate of DC to DC converter used in solar power supply unit is  $1.5 \times 10^{-6}$  and for the associated components is  $1 \times 10^{-4}$ . The DC to DC output of solar power unit is connected before the pony motor battery inverter circuit. With this additional power source and the existing two power supply paths, the

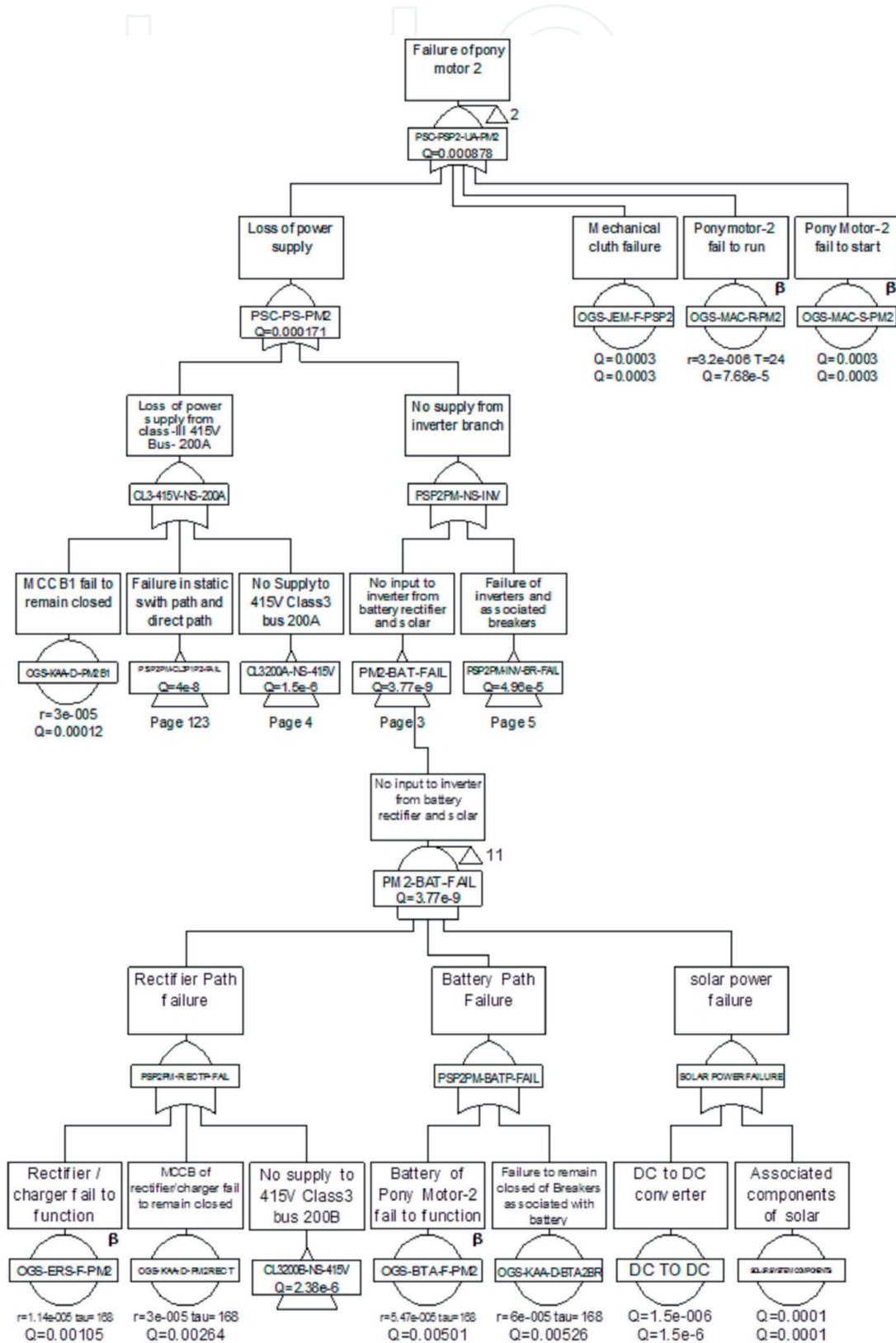

Figure 8. Fault tree for failure of pony motor with proposed power supply scheme.

overall failure rate of the pony motor UPS is found to be  $3.77 \times 10^{-9}$ . This brings the overall failure rate of pony motor to 0.000878 as shown in **Figure 8** [30, 31].

## 7. Results and discussions

The failure rate with addition of solar power supply unit to the Pony Motor UPS system reduces the failure rate of the Pony Motor by several decades, i.e., from 0.0149 to 0.000878. With this new addition of solar power to the existing scheme, the availability of the Pony Motor is increased.

The prevailing nuclear power plants are having Grid power supply, Emergency Diesel Generators, UPS AC supply, Battery backup DC supply and ADGs for, safe shutdown and decay heat removal mission of the reactor. A complete loss of power supply for reactor cooling system was considered as BDBE for which the frequency occurrence is very remote and was neglected before Fukushima incident. However, the Fukushima incident has given a lesson to all the nuclear operators across the globe that the plant should be equipped to handle even the BDBE situations also. Hence, to overcome the above issues World Association for Nuclear Operators (WANO) has recommended that all nuclear power plant should have Emergency DGs along with an additional mobile DGs (ADG) for emergency situations. Further, to strengthen the backup power supply and to overcome the beyond design basis event solar power can be integrated with existing arrangement. This hybrid solar power will increase the reliability of the system and will reduce the non-availability of power supply failure during BDBE. The proposed arrangement reliability was also analyzed through software and found that it is increasing the reliability of the existing set up. A tropical country like India has solar radiation for 10 out of 12 months. Hence, the solar power will be used as backup power for nuclear power plant.

## 8. Conclusion

The prevailing nuclear power plants are having grid power supply, emergency diesel generators, UPS AC supply, battery backup DC supply, and ADGs for safe shutdown and decay heat removal mission of the reactor. A complete loss of power supply for reactor cooling system was considered as BDBE for which the frequency occurrence is very remote and was neglected before Fukushima incident. However, the Fukushima incident has given a lesson to all the nuclear operators across the globe that the plant should be equipped to handle even the BDBE situations. Hence, to overcome the above extreme events, the World Association for Nuclear Operators (WANO) has recommended that all nuclear power plant should have emergency DGs along with an additional mobile DGs (ADG) for emergency situations. Further, to strengthen the backup power supply and to overcome the beyond design basis event, solar power can be integrated with existing arrangement. This hybrid solar power will increase the reliability of the system and will reduce the non-availability of power supply failure during BDBE.

The proposed arrangement reliability was also analyzed through software and found that it is increasing the reliability of the existing setup. A tropical country like India has solar radiation for 10 out of 12 months. Hence, the solar power will be used as a backup power for nuclear power plants. The failure rate with addition of solar power supply unit to the Pony Motor UPS system reduces the failure rate of the Pony Motor by several decades, i.e., from 0.0149 to 0.000878. With this new addition of solar power to the existing scheme, the availability of the Pony Motor is increased. The hybrid solar power supply system utilized in nuclear reactors is

highly reliable to the reactor safe shutdown system during day time emergency requirement. However, during night time, the stored power supply from the batteries will cater the essential loads in discharge mode. Onset of the solar power batteries will get charged again. The batteries shall be sized to store enough power to take care of the night time requirement. In addition to this, it is proposed to integrate emergency DG, additional mobile DG (ADG), and solar power with wind power for the future nuclear reactors which may increase the reliability further thereby ensuring the plant is capable of handling any BDBE that occurred in Fukushima—Daiichi.

IntechOpen

IntechOpen

### **Author details**

Kudiyarasan Swamynathan\*, P. Sivakumar and K. Karthikeyan  
Bharatiya Nabhikiya Vidyut Nigam Limited, Department of Atomic Energy,  
Kalpakkam, Tamilnadu, India

\*Address all correspondence to: kudiyarasan@rediffmail.com

### **IntechOpen**

© 2020 The Author(s). Licensee IntechOpen. This chapter is distributed under the terms of the Creative Commons Attribution License (<http://creativecommons.org/licenses/by/3.0>), which permits unrestricted use, distribution, and reproduction in any medium, provided the original work is properly cited. 

## References

- [1] Taner T. Energy and exergy analyse of PEM fuel cell: A case study of modelling and simulations. 2018;**143**:284-294. DOI: 10.1016/j.energy.2017.10.102
- [2] Taner T, Sivrioglu M. A techno-economic and cost analysis of a turbine power plant: A case study of sugar plant. *Renewable and Sustainable Energy Reviews*. 2017;**78**:722-730. DOI: 10.1016/j.rser.2017.04.104
- [3] Taner T. Optimisation processes of energy efficiency for a drying plant: A case of study for Turkey. *Applied Thermal Engineering*. 2015;**80**:247-260. DOI: 10.1016/j.applthermaleng.2015.01.076
- [4] Taner T, Sivrioglu M. Energy-exergy analysis and optimisation of a model sugar factory in Turkey. *Energy*. 2015;**93**(1):641-654. DOI: 10.1016/j.energy.2015.09.007
- [5] Taner T, Sivrioglu M. A techno-economic and cost analysis of a turbine plant: A case study for sugar plant. *Renewable and Sustainable Energy Reviews*. 2017;**78**:722-730. DOI: 10.1016/j.rser.2017.04.104
- [6] Topal H, Taner T, Altıncı Y, Amirabedin E. Application of trigeneration with direct co-combustion of poultry 1 waste and coal: A case study in the poultry industry from Turkey. *Thermal Science*. 2017 (In Press). DOI: 10.2298/TSCI170210137T
- [7] Topal H, Taner T, Naqvi SA, Altınsoy Y, Amirabedin E, Ozkaymak M. Exergy analysis of a circulating fluidized bed power plant co-firing with olive pits: A case study of power plant in Turkey. *Energy*. 2017;**140**:40-46. DOI: 10.1016/j.energy.2017.08.042
- [8] Taner T. Economic analysis of a wind power: A case study for the Cappadocia region. *Journal of Mechanical Science and Technology*; **32**(3):1379-1389. DOI: 10.1007/s12206-018-0241-6
- [9] Taner T, Demirci OK. Energy and economic analysis of the wind turbine Plant's drafts for the Aksaray city. *Applied Ecology and Environmental Sciences*. 2014;**2**(3):82-85. DOI: 10.12691/aees-2-3-2
- [10] Taner T, Sivrioglu M, Topal H, Wongwises S. A model of energy management analysis, case study of sugar factory in Turkey. *Sadhana-Academy Proceedings in Engineering Sciences*. 2018;**43**(3):1-20. DOI: 10.1007/s12046-018-0793-2
- [11] Taner T, Demirci OK. Energy and economic analysis of the wind turbine plants of the Aksaray city. *Applied Ecology and Environmental Sciences*. 2014;**2**(3):82-85. DOI: 10.12691/aees-2-3-2
- [12] Raghupathy S, Singh OP, Govindarajan S, Chetal SC, Bhoje SB. Design of 500 Mwe prototype fast breeder reactor. Indira Gandhi Centre for Atomic Research; [http://www.efn-uk.org/nuclear/nuc-lib/reactor-reports/index\\_files/India-PFBR-design.pdf](http://www.efn-uk.org/nuclear/nuc-lib/reactor-reports/index_files/India-PFBR-design.pdf)
- [13] Bhoje SB, Chetal SC, Chellapandi P, Govindarajan S, Lee SM, Kameswara R, et al. Impact of LMFBR Operating Experience on PFBR Design. Kalpakkam, India: Indira Gandhi Centre for Atomic Research; 2000. [https://inis.iaea.org/collection/NCLCollectionStore/\\_Public/31/058/31058490.pdf](https://inis.iaea.org/collection/NCLCollectionStore/_Public/31/058/31058490.pdf)
- [14] Sundaram CV, Lee SM. Physics and engineering aspects of fast reactor safety. *Pramana*. 1985;**24**(1-2):193-210
- [15] Prasad M, Theivarajan N. Normal power supply system of a nuclear power plant-modelling and simulation studies for fast bus transfer. In: IEEE, 1st International Conference on Electrical Energy Systems. Newport Beach, CA; 2011:294-299

- [16] Raja K, Theivarajan N. Emergency power supply system of a nuclear power plant-modelling and simulation studies of diesel generators and load pickup on emergency transfer. In: IEEE, 1st International Conference on Electrical Energy Systems. Newport Beach, CA; 2011:302-307
- [17] SubbaRaju B, VijayaKumar K, Seetha H, Jayanthi T, Satya Murthy SAV. Modeling and simulation of emergency power supply system and emergency transfer scheme for PFBR operator training simulator. International Research Journal of Engineering and Technology. 2015;02(03):1600-1605
- [18] Nawlakha R, Jasmine N, Subba Raju B, Seetha H, Jayanthi T, SatyaMurthy SAV. Modeling and simulation of backup control room for PFBR operator training simulator. International Journal of Energy Engineering. 2012;2(4):125-130
- [19] Kim J, Jae M. A study on reliability assessment of a decay heat removal system for a sodium-cooled fast reactor. Journal of Nuclear Science and Technology. 2018:534-539
- [20] Yang Y, Sangwongwanich A, Blaabjerg F. Design for Reliability of power electronics for grid-connected photovoltaic systems. CPSS Transactions on Power Electronics and Applications. 2016;1(1):92-103
- [21] Inhaber H. Is solar power more dangerous than nuclear. IAEA Bulletin;21(1):11-17
- [22] El-Metwally M, EL-Shimy M, Elshahed M, Sayed A. Detailed Analyses of the Failure and Repair Rates of Wind and Solar-PV Systems for RAM Assessment. ICEENG-11; 2017. DOI: 10.13140/RG.2.2.18530.84160
- [23] Popov D, Borissova A. Innovative configuration of a hybrid nuclear-solar tower power plant. Energy. 2017;125:736-746
- [24] Nourbakhsh HP. Dealing with beyond-design-basis accidents in nuclear safety decisions. Presented at 12th International Probabilistic Safety Assessment and Management (PSAM 12) Conference. Honolulu, Hawaii, USA; 22-27 June 2014
- [25] Shang Z, Zhu J, Zheng M. Considerations at beyond design-basis phenomenon design for new nuclear power plant seismic and Tsunami. Transactions, Smirt-22 San Francisco, California, USA, Division IV; 2013
- [26] Merk B, Stanculescu A, Chellapandi P, Robert Hill R. Progress in reliability of fast reactor operation and new trends to increased inherent safety. Applied Energy. 2015;147:104-116
- [27] Adail AS, Hassan HM, Shaat MK. Safety and reliability of the electrical system based on optimal FACTS allocation for a research reactor. Progress in Nuclear Energy. 2018;104:143-149
- [28] Zeliang C, Singh OP, Munshi P. Uncertainty evaluation of reliability of shutdown system of a medium size fast breeder reactor. Nuclear Engineering and Design. 2016;308:283-296
- [29] Sharma PK, Bhuvana V, Ramakrishnan M. Reliability analysis of diesel generator power supply system of prototype fast breeder reactor. Nuclear Engineering and Design. 2016;310:192-204
- [30] Arul J, Senthil Kumar C, Athmalingam S, Singh OP, Rao KS. Reliability analysis of safety grade decay heat removal system of Indian prototype fast breeder reactor. Annals of Nuclear Energy. 2006;33:180-188
- [31] Ramakrishnan M. Integration of functional reliability analysis and system hardware reliability through Monte Carlo simulation. Annals of Nuclear Energy. 2016;95:54-63