

Ontologies and Formation Spaces for Conceptual ReDesign of Systems

J. Bíla, M. Tlapák

This paper discusses ontologies, methods for developing them and languages for representing them. A special ontology for computational support of the Conceptual ReDesign Process (CRDP) is introduced with a simple illustrative example of an application. The ontology denoted as Global context (GLB) combines features of general semantic networks and features of UML language. The ontology is task-oriented and domain-oriented, and contains three basic strata – GLB_{Expl} (stratum of Explanation), GLB_{FAct} (stratum of Fields of Activities) and GLB_{Env} (stratum of Environment), with their sub-strata. The ontology has been developed to represent functions of systems and their components in CRDP. The main difference between this ontology and ontologies which have been developed to identify functions (the semantic details in those ontologies must be as deep as possible) is in the style of the description of the functions. In the proposed ontology, Formation Spaces were used as lower semantic categories the semantic deepness of which is variable and depends on the actual solution approach of a specialised Conceptual Designer.

Keywords: ontologies, conceptual redesign, fields of activities, principles, UML.

1 Introduction

The approach of Artificial Intelligence disciplines to support for design problem solution synthesis has changed qualitatively in recent times. The traditional interest in sophisticated formal means for system design (description of components, procedures of system synthesis from components, etc.) is now targeted at semantic modelling and at an effective description of the functions of the designed systems. The field which promises the necessary improvements in modelling the semantics is the field of *ontologies*.

2 Ontologies

An extended interpretation of the term “ontology” (e.g. in [1, 11]) in the context of this paper is as follows:

An ontology is a specification of the way of conceptualisation that is used.

The internal basis of an ontology is given by the methods for knowledge acquisition, knowledge representation, knowledge sharing, knowledge management and data retrieval. The formal “shape” of an ontology depends on the means used representation that is used (the most general “ancestor” is a semantic network).

Essential points for specifying ontology (with respect to the ontologies discussed in this paper) include:

- Purpose and objective of the development and application of the ontology.
- Subject domains and tasks relevant for the development and application of the ontology.
- Classes, relations, functions and other formal categories which will be used for conceptualisation.
- Way of working with the ontology, the form of computer support and the user of the ontology.
- Terminology used in the ontology (“schools”, traditions and usage).
- Implementation environment in which the ontology will be developed and applied.

2.1 Languages for representation of ontologies

From the list of “older” semantic formalisms which can nowadays be considered as ontologies, we mention only By-

lander’s consolidations [2]. Consolidations are graphic-symbolic formations to describe functions on the level of principles. In combination with Suh’s axiomatic theory of design [4], knowledge acquisition and knowledge representation were used to explain the system functions and for system design [3]. They are still used, e.g., in systems for automatic identification of functional structures, [5].

One of the most powerful means for representing ontologies is ONTOLINGUA, [7, 8]. Its basic layer is done by KIF language (Knowledge Interchange Formate), [6], which is a variant of predicate first order language with the syntax of LISP. CYCL language is a language of the CYC project. It is based on LISP syntax and, like KIF, it follows the features of predicate first order language. (Some parts of the developed ontology – 6000 concepts and 60 000 assertions – are available in [12].) Of the many of other languages for representation of ontologies, the following are widely used: OCML (Ontology Compositional Modelling Language), DAML-ONT (Darpa Agent Mark-Up Language-ONTology), OIL (Ontology Inference Layer) and DAML+OIL. Details, e.g., in [13].

2.2 UML Language and its use for representation of ontologies

UML (Unified Modelling Language, [9]) was developed by OMG (Object Management Group) for the analysis and design of large software systems. It is nowadays also used for other applications, especially in the fields of analysis and design of general systems, for conceptual design and also for the representation of ontologies [14].

UML works with 8 layers of models. For conceptual design and for the representation of ontologies most important are: *class diagrams* (which express the necessary relations between elements of conceptual categories, such as classes, associations, attributes, operations, dependencies, relations between dependencies), *state diagrams* (to describe dynamic processes inside the classes) and *sequence diagrams* (to describe dynamic processes in established tasks with interaction between the classes).

Though UML has been accepted as one of languages for representation of ontologies it has two principal disadvantages: limited semantics of associations in the layer of

class diagrams, and the absence of means for the inference of novel knowledge. The importance of these two obstacles has been decreased by modifications and extensions of UML. (The second obstacle has been only partially solved by means of OCL (Object Constraint Language) [10] and by the addition of a special inference system.)

3 An ontology for Conceptual Design

We sketch here the essential characteristics of Conceptual Design:

- Conceptual Design starts by specifying a goal-designed system, and it results in a functional structure usually called *the scheme*.
- *The scheme* has substantial features of the product or system which is being designed, but need not necessarily contain geometrical and quantitative data.
- There are two roles of *the scheme*:
 - To explain the function of a designed system.
 - To describe the basic features of a designed system structure (components, materials, relevant relations, rough computations and estimations).
- The field of Conceptual Design may be decomposed (according to the type of designed systems) into three classes:
 - A. *Conceptual design of systems* (control systems, technological systems, transport systems, telecommunication systems).
 - B. *Conceptual design of technological components, machines and devices* (holders, attachment tools, frames, bicycles, cars, paragliding sets, refrigerators, heat pumps).
 - C. *Conceptual design of configurations* (flats, buildings, parks, allocation of machines in halls, ...).
- (Before the Conceptual Design phase there is usually an Early Design phase, and the Conceptual Design phase is followed by a Detailed Design phase.)

UML language (mentioned in the previous section) may be directly used for Conceptual Design of systems of group A systems [14]. On the other hand, the development of ontologies for group B systems and products is particularly interesting.

3.1 Ontology for representation of functions in conceptual redesign of systems in group B

An ontology that has been developed for conceptual *redesign* now will be proposed. Conditions for *redesign* (where the specification of a novel system – the goal of a redesign process – is done by conditions for improving the “old” system) enable us to develop an effective but not too extensive ontology. (Details about redesign methods are given, e.g., in [15, 16, 17]). The ontology denoted as a Global context (GLB) combines the features of general semantic networks and the features of UML language. The ontology is task-oriented and domain-oriented, and contains three basic strata (with their sub-strata):

GLB_{Expl} ... stratum of Explanation,

GLB_{Fact} ... stratum of Fields of Activities,

GLB_{Env} ... stratum of Environment.

Stratum *Fields of Activities* (GLB_{Fact}) has 5 sub-strata (Principles): GLB_{Princ1} , GLB_{Princ2} , GLB_{Princ3} , GLB_{Princ4} , GLB_{Princ5} .

A structure of strata and sub-strata is shown in Fig. 1, which corresponds, to expression (1):

$$GLB = \langle GLB_{Expl}, GLB_{Fact} \langle GLB_{Princ1} \langle GLB_{Princ2} \langle GLB_{Princ3} \langle GLB_{Princ4}, GLB_{Princ5} \rangle \rangle \rangle \rangle, GLB_{Env} \rangle. \quad (1)$$

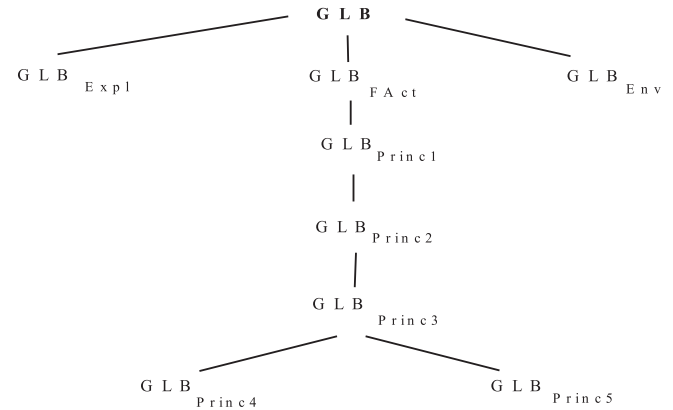

Fig. 1: A partial ordering of strata in GLB ontology

Strata and sub-strata GLB_{Fact} , GLB_{Princ1} , GLB_{Princ2} , GLB_{Princ3} have the structure of models

$$GLB_p = \langle Fam_p, \mathfrak{R}(Fam_p) \rangle. \quad (2)$$

Strata and sub-strata GLB_{Expl} , GLB_{Princ4} , GLB_{Princ5} and GLB_{Env} have the structure of algebras

$$GLB_p = \langle Fam_p, F(Fam_p) \rangle, \quad (3)$$

where Fam_p are carriers of models and algebras ($p \in \{Expl, Fact, Princ1, Princ2, Princ3, Princ4, Princ5, Env\}$), $\mathfrak{R}(Fam_p)$ are systems of relations and $F(Fam_p)$ are systems of operations introduced in carriers Fam_p . Carriers Fam_p of models and algebras will in this paper be called “families” (as in [16]) and, their elements will be called “Formation Spaces” (denoted as FS).

Note: In this paper, only fragments of an ontology from stratum Fact are demonstrated. The description of their sub-strata is very brief, limited by the requirements of Example 1.

Stratum “Field of Activities” (Fact):

Carrier “ Fam_{Fact} ” contains formation spaces of the type

$$Fam_{Fact} = \{ME, PNU, HME, ELS, MSF, TCS, \dots\}, \quad (4)$$

with the following meaning:

ME ... Mechanics, **PNU** ... Pneumatics, **HME** ... Hydro-mechanics, **ELS** ... Electrical and Electronics (field of activities), **MSF** ... Mathematics, Symbolic and Formal (field of activities), **TCS** ... Technological Constructions (bridges, frames, walls, ...).

Stratum “Principles 1” (Princ1):

Carrier “ Fam_{Princ1} ” contains formation spaces of the type

$$Fam_{Princ1} = \{Agg, Trns, Contr, Protc, Cnstr, R - Eff, Instr, Dam, Emb, Prod\}, \quad (5)$$

with the following meaning:

Agg ... Aggregation, **Trns** ... Transformation, **Contr** ... Control, **Protc** ... Protection, **Cnstr** ... Constructions, **R-Eff** ...

Relative Effects, **Instr** ... Instrumental, **Dam** ... Damage, **Emb** ... Embedding, **Prod** ... Production.

Stratum “Principles 2” (Princ2):

Carrier “*Fam_{Princ2}*” contains formation spaces of the type *Fam_{Princ2}* =

- {Agg⟨**Accum**, **Synth**⟩,
- Trns⟨**ChCarrV**, **Transfer**, **Transms**, **ChBeh**, **ChVVal**⟩,
- Contr⟨**Rep**, **Supp**, **Catal**, **Analog**, **Logic**, **F-Logic**⟩,
- Protc⟨**ProtcProd**, **ProtcProp**, **ConsvState**⟩,
- Cnstr⟨**Separ**, **Fix**, **Bear**, **Content**, **Join**, **Milieu**⟩, (6)
- R-Eff⟨**Filter**, **Joint**, **Bearing**⟩,
- Instr⟨**Tool**, **Material**, **Means**⟩,
- Dem⟨**Discard**, **Contamin**, **Destruct**⟩,
- Emb⟨**InConstr**, **Include**, **Annex**⟩,
- Prod⟨**Object**, **UnivQual**, **UnivPower**⟩},

with the following meaning:

Accum ... Accumulation (Aggregation without change of the aggregated components), **Synth** ... Synthesis (Aggregation with a change of the aggregated components), **ChCarr** ... Change of Energy Carriers, **ChCarrV** ... Change of Carrier Variables, **Transfer** ... Change of position of energy matter with possible changes of the internal properties, **Transms** ... (Transmission) Change of position of energy matter without changes of the internal properties, **ChBeh** ... Change of Behaviour of Energy matter, **ChVVal** ... Change of Values of descriptive variables, **Rep** ... Repression of an effect (process, principle), **Supp** ... Support of an effect (process, principle), **Catal** ... Catalysation of an effect (process, principle), **Analog** ... Analog control of an effect (process, principle), **Logic** ... Logic control of an effect (process, principle), **F-Logic** ... Fuzzy Logic control of an effect (process, principle), **ProtcProd** ... Protection of Products, **ProtcProp** ... Protection of Properties, **ConsvState** ... Conservation of a State, **Separ** ... to Separate, **Fix** ... to Fix, **Bear** ... to Bear, **Content** ... to form a volume, **Join** ... to Join, **Milieu** ... to form a Milieu, **Filter** ... Filter, **Joint** ... Joint, **Bearing** ... generalised bearing, **Tool** ... Tool, **Material** ... Material, **Means** ... Means (non special facilities to help an effect or action), **Discard** ... to Discard (to eliminate the existence), **Contamin** ... to Contaminate, **Destruct** ... to Destruct, **InConstr** ... to embed in a system and to use the functionality (of the embedded system or of both), **Include** ... to embed without specified utilisation of functionalities, **Annex** ... to Annex, **Objects** ... production of Objects, **UnivQual** ... production of Universal Qualities (money, water, light, foodstuffs), **UnivPower** ... production of Universal Powers (electrical energy, heat).

Strata “Principles 3” (Princ3), “Principles 4” (Princ4), “Principles 5” (Princ5):

The stratum “*Principles 3*” contains UML class diagrams, Stratum “*Principles 4*” contains UML state diagrams related to the relevant class diagram from stratum “*Principles 3*”, and stratum “*Principles 5*” contains UML sequence diagrams related to the relevant class diagram from stratum “*Principles 3*”.

For each line FAct – Princ1 – Princ2 there exists at least one class, state or sequence diagram (according to need). (In the final stage XML language will be used to represent the diagrams from strata *Princ3*, *Princ4*, *Princ5*).

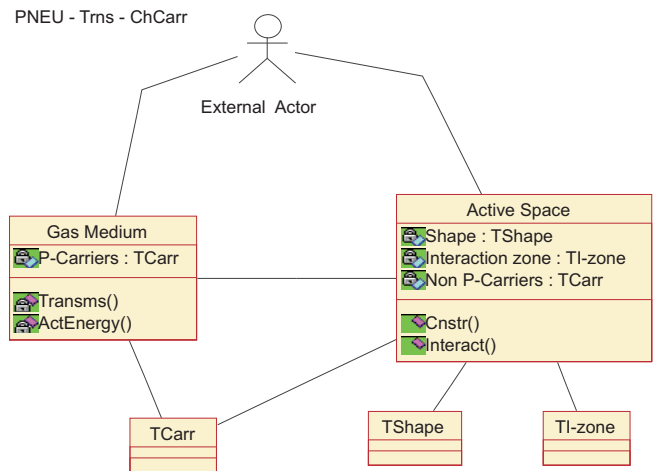

Fig. 2: Class diagram for principle “PNEU – Trns – CHCarr”

An example of a class diagram and a sequence diagram for the principle “**PNEU – Trns – CHCarr**” is illustrated in Fig. 2. and Fig. 3. The class diagram expresses a process in which three main classes participate – **External Actor** (man, Nature, a pneumatic system, ...), **Gas Medium** and **Active Space**. Gas Medium has attribute **P-Carriers** (pneumatic carriers of energy) and two operations (principles) **Transms** (Transmission) and **ActEnergy** (Activation of Energy). Class Active Space has attributes **Shape**, **Interaction Zone** and **Non P-Carriers** (non pneumatic carriers). Operation (principle) “**Cnstr**” (Construction) provides a shaping of **Interaction Zone** and operation **Interact** performs the interaction of **Non P-Carriers** in the interaction zone. A detailed description (if needed) will be introduced in classes **TCarr** (class of carriers),

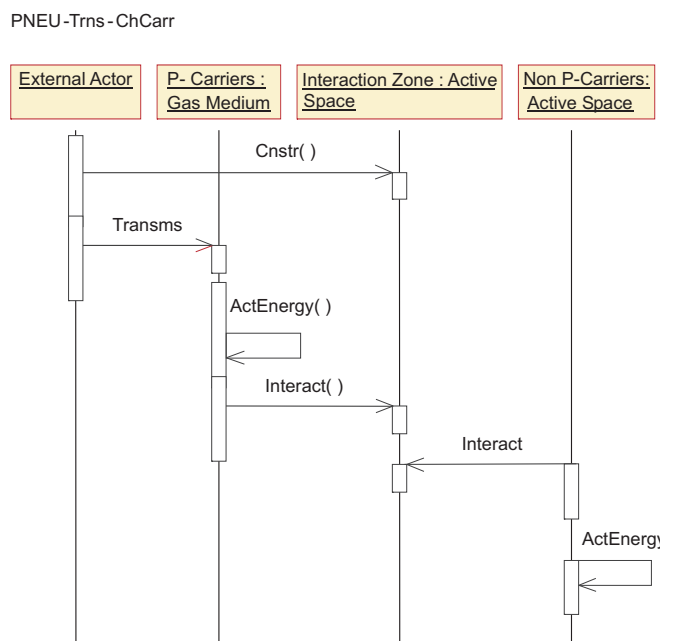

Fig. 3: Sequence diagram for principle “PNEU – Trns – CHCarr”

TShape (class of shapes) and **TI-zone** (class of interaction zones). The sequence diagram in Fig. 3 expresses the dynamics of the described principle („PNEU –Trms“ – CHCarr) where lines with arrows denote operations and lower principles as events between objects and their order in event time. The first event **Cnstr** is started by the **External Actor** and it is oriented to object **Active Space**. The second event is the operation (principle) **Transms** (induced by **External Actor** and it is oriented to **Interaction Zone** of **Active Space**). (Further description is obvious.)

Example 1: For illustration we now introduce a fragment $GLB_{FAct} \langle GLB_{Princ1} \langle GLB_{Princ2} \langle - \langle GLB_{Princ4}, - \rangle \rangle \rangle \rangle$ of ontology which describes the function of a sensor. This is a sensor for measuring the flow of gas, which has to improve the properties of the measurement orifice.

Compared with the ontology from [3] and [5], which were developed to identify functions, the proposed fragment of ontology has to advise the designer which Fields of Activities and Principles a novel device (sensor) may be formed from. (The procedure for automated synthesis of functional structures is introduced, e.g., in [15, 16].) One possible functional structure is described by the following expression **x**:

$$\begin{aligned}
 \mathbf{x} = & \text{Fact}(\text{PNEU} \langle \text{Princ1}(\text{Trans} \langle \text{Princ2}(\text{ChCarr AND} \\
 & \text{ChValV AND Transms AND ChBeh}) \rangle \rangle \text{ AND} \\
 & \text{Contr} \langle \text{Princ2}(\text{Analog}) \rangle \text{ AND Cnstr} \langle \text{Princ2}(\text{Shape}) \rangle \rangle \rangle \text{ AND} \\
 & \text{ME} \langle \text{Princ1}(\text{Agg} \langle \text{Princ2}(\text{Accum}) \rangle \text{ AND} \\
 & \text{Trans} \langle \text{Princ2}(\text{ChCarrV AND ChBeh}) \rangle \text{ AND} \\
 & \text{Contr} \langle \text{Princ2}(\text{Analog}) \rangle \text{ AND R-Eff} \langle \text{Princ2}(\text{Bearing}) \rangle \rangle \text{ AND} \\
 & \text{Cnstr} \langle \text{Princ2}(\text{Separ AND Fix AND Shape}) \rangle \rangle \rangle
 \end{aligned}$$

Expression **x** contains a structure of instances of Fields of Activities and Principles for a given case. The state diagram in Fig. 4. represents these facts: A solution which is searched for is in the activities of pneumatic (**PNEU**) and mechanical (**ME**) Fields of Activities. The time sequence of states starts in Preparatory State in field **PNEU** (**P-State PNEU**), which is left in the situation when the quantity of variable **VI** is higher than the lower limit quantity **VIL** and when a certain construction shaping of the space of gas flow ($(\text{VALV1} > \text{VALV1L}) \text{ AND Cnstr}(\text{Shape})$) is provided. In **Active State PNEU 1** there are Changed Carriers of energy (and information) (**ChCarr**), the flow of the gas continues (**Transms**) till the Change of Behaviour of the gas flow into type **Beh PNEU1** (**ChBeh: BehPNEU1**), and **Active State ME 1** (**Cnstr(Shape)** AND (**ChBeh: BehPNEU1**)) starts. In **Active State ME 1** there is changed and differentiated behaviour of mechanical components **ChBeh: Beh ME1**, (using the principles of fixation (**Cnstr(Fix)**) and of relative effect (generalised bearing) (**R-Eff(Bearing)**) and the quantities of the variables of the energy carriers (**ChCarrV**) are changed. Releasing the transition from **Active State ME 1** into **Active State PNEU 2** (in exit from **Active ME 1**) a part of the flow space (**Cnstr(Separ)**) is separated, and the quantity of a variable is aggregated **Agg(Accum)**. The process continues by transition into **Active State PNEU 2** (achieving a change of behaviour of the mechanical components into type **Beh ME2** (still satisfying the condition of the shape of the space flow), etc.) (Description of further steps is obvious.)

*Note: The state diagram does not contain all relevant principles which are introduced in solution **x**, and does not contain the precise*

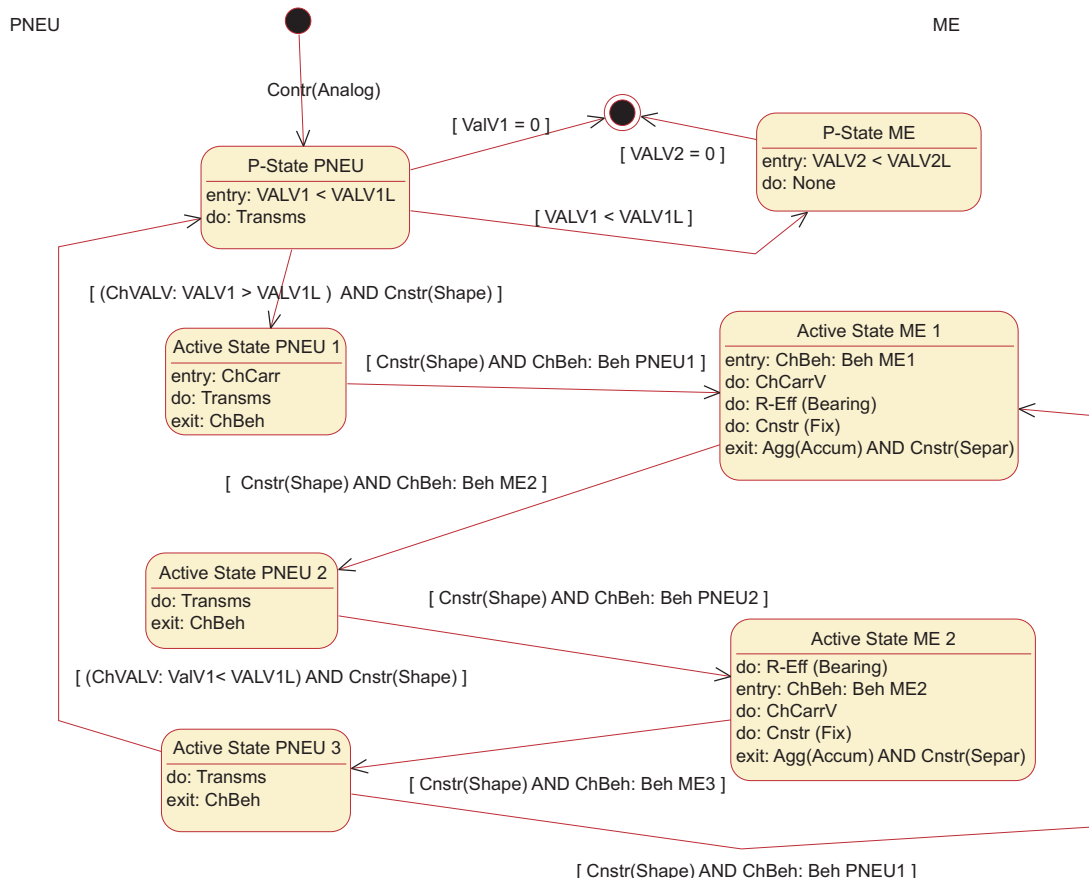

Fig. 4: Description of a structure of principles from Fields of Activities PNEU and ME by State diagram

orientation of the principles to all possible arguments. The expression **Contr(Analog)** – for example – holds for the whole diagram as a condition inducing transitions between states (though it is introduced only at the beginning of the diagram). Similarly the extension of the influence of principle **Agg(Accum)** is not precisely determined. However, there is no need to describe all circumstances in “hard” detail, because the diagram has the role of an intelligent prompter (similarly as solution **x**).

Expression **x** and the state diagram (Fig. 4) describe the function of a device for measuring flow, where in the interaction of the principles of the mechanical and pneumatic fields a cyclic alternation of the behaviour of the gas flow and the behaviour of the mechanical components is established. This cyclic process induces aggregation (accumulation) of the quantities (values) of some variable.

One possible interpretation of the proposed solution is the device in Fig. 5 (details in [19]).

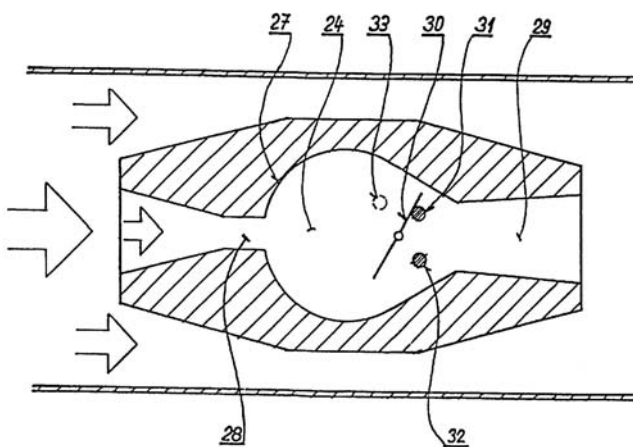

Fig. 5: One possible interpretation of solution **x** of the conceptual redesign problem from Example 1. (Description: **30** ... flapper, **31**, **32**, **33** ... constraint pins, **28**, **29** ... input and output neck, **24** ... interaction space, **27** ... shaped wall of the interaction space)

4 Conclusions

The development of ontologies for many different engineering domains represents a synthesis of present-day informatic and engineering methods. This paper has shown the increasing importance of an effective ontology for computer support of problem solving in conceptual design.

5 Acknowledgments

This research has been conducted at the Department of Instrumentation and Control Engineering, Faculty of Mechanical Engineering, Czech Technical University in Prague and has been supported by Research Grant MŠM 68 40 77 0008.

References

- [1] Guarino, N., Giaretta, P.: *Ontologies and Knowledge Bases, Towards a Terminological Clarification*, <http://www.ladseb.pd.cnr.it/infor/Ontology/Papers/KBKS95.pdf>, 1995.
- [2] Bylander, T., Chandrasekaran, B.: “Generic Tasks in Knowledge-Based Reasoning: The Right Level of Abstraction for Knowledge Acquisition.” In: (Gaines, B. R., Boose, J. H., Eds.) *Knowledge Acquisition Based Systems*. London, Academic Press., Vol. 1 (1988), p. 65–77.
- [3] Katai, O., Kawakami, H., Sawaragi, T., Konishi, T., Iwai, S.: “Method of Extracting Meta Plan for Designing from Artefacts Analysis Based on Axiomatic Design Theory.” *Transactions of the Society of Instrument and Control Engineers*, Vol. 31 (1995), No. 3, p. 347–356.
- [4] Suh, N. P.: *The Principles of Design*. Oxford University Press. 1990.
- [5] Kitamura, Yo., Toshinobu, S., Namba, K., Mizoguchi, R.: “A Functional Concept Ontology and its Application to Automatic Identification of Functional Structures.” *Advanced Engineering Informatics*, Vol. 16 (2002), No. 2, p. 145–163.
- [6] Michael, R. G.: “Knowledge Interchange Format.” In: (Fikes, R., Allen, J. A., Sandewall, E., Eds.) *Proc. of 2nd Int. Conf. on Principles of Knowledge Representation and Reasoning*. Cambridge, MA, 1991, p. 599–600.
- [7] Gruber, T. R.: “Translation Approach to Portable Ontology Specifications.” *Knowledge Acquisition*, Vol. 5 (1993), No. 2., p. 199–220.
- [8] Gruber, T. R., Olsen, G. R.: “An Ontology for Engineering Mathematics.” In: (Doyle, J., Torasso, P., Sandewall, E., Eds.) *4th Int. Conf. on Principles of Knowledge Representation and Reasoning*. Bonn, Morgan Kaufmann, 1994, p. 256–278.
- [9] Rumbaugh, J., Jacobson, I., Booch, G.: *The Unified Modelling Language Reference Manual*. Addison-Wesley, 1998.
- [10] Warmer, J. B., Kleppe, A. G.: *The Object Constraint Language: Precise Modelling with UML*. Addison-Wesley, 1998.
- [11] Brasethvik, T., Gull, J.: “Natural language analysis for semantic document modelling.” *Data and Knowledge Engineering*, 2001, No. 38, p. 45–62.
- [12] <http://www.opencyc.org/>
- [13] Svátek, V.: “Ontologies and WWW.” In: *Proc. of Int. Conference Datacon*, 2002. <http://www.cogsci.princeton.edu/~wn/>
- [14] Cranfield, S., Purvis, M.: “UML as an Ontology Modelling Language.” In: *Proc. of Workshop on Intelligent Information Integration*, 16th Int. Joint Conf. on Artificial Intelligence – IJCAI ’99, 1999, p. 119–127.
- [15] Bíla, J.: “Degree of Emergence in Evolutionary Synthesis Process.” In: *Proc. of Int. IASTED Conference on Neural Networks – NN 2000*, Pittsburgh, PA, 2000, p. 142–147.
- [16] Bíla, J.: “One Variant of the Emergence Phenomenon in the Design Process and its Computer Support.” Submitted for *Automation in Construction* (ISSN 0926-5805), 2003.
- [17] Bíla, J.: “Emergent Phenomena in a Co-Evolutionary Conceptual Design.” *Proc. of Int. Conf. Artificial Intelligence in Design – AID 02*, Cambridge, England, (2002) CD- ROM with poster papers, paper No.1.

[18] Bíla, J., Tlapák, M.: "Application of Ontologies in Mechanical Engineering." In: Proc. of Workshop on "The Development of Methods and Tools in Integration of Mechanical Engineering. Faculty of Mechanical Engineering, CTU in Prague, Prague, CR, 2003, p. 20–24. ISBN 80-01-02866-6.

[19] Bíla, J., Preisler, V.: *The Device for Measurement of Flows and Amounts of Gases*. Utility Model No. CZ 11576 U1, The Office for Industry Properties, Prague, CR, 2001.

Prof. Ing. Jiří Bíla, DrSc.
phone: +420 224 352 534

fax: +420 233 336 414
e-mail: Jiri.Bila@fs.cvut.cz

Mgr. Miroslav Tlapák
e-mail: miroslav.tlapak@fs.cvut.cz

Dept. of Instrumentation and Control Engineering

Czech Technical University in Prague
Faculty of Mechanical Engineering
Technická 4
166 07 Prague 6, Czech Republic