

# Open Research Online

---

The Open University's repository of research publications and other research outputs

## Propagation of Power Line Carrier Signals Through the Distribution Transformer.

### Thesis

How to cite:

Horridge, Paul (1996). Propagation of Power Line Carrier Signals Through the Distribution Transformer. PhD thesis. The Open University.

For guidance on citations see [FAQs](#).

© 1996 Paul Horridge

Version: Version of Record

---

Copyright and Moral Rights for the articles on this site are retained by the individual authors and/or other copyright owners. For more information on Open Research Online's [data policy](#) on reuse of materials please consult the policies page.

---

[oro.open.ac.uk](http://oro.open.ac.uk)

**"Propagation of Power Line Carrier Signals  
Through the Distribution Transformer"**

UNRESTRICTED

by

**Paul Horridge**

**B.Eng ( Hons ) , A.M.I.E.E**

**A Thesis Submitted to the**

**OPEN UNIVERSITY**

**Faculty of Technology**

**Discipline of Electronics**

**For the degree of**

**DOCTOR of PHILOSOPHY**

*Date of submission: 20 February 1996*  
*Date of award: 17 April 1996*

**February 1996**

ProQuest Number: C526309

All rights reserved

INFORMATION TO ALL USERS

The quality of this reproduction is dependent upon the quality of the copy submitted.

In the unlikely event that the author did not send a complete manuscript and there are missing pages, these will be noted. Also, if material had to be removed, a note will indicate the deletion.



ProQuest C526309

Published by ProQuest LLC (2019). Copyright of the Dissertation is held by the Author.

All rights reserved.

This work is protected against unauthorized copying under Title 17, United States Code  
Microform Edition © ProQuest LLC.

ProQuest LLC.  
789 East Eisenhower Parkway  
P.O. Box 1346  
Ann Arbor, MI 48106 – 1346

## Acknowledgements

The author wishes to express gratitude to the help and facilities provided by Professor Dennis Allen of GEC Alstom , Transformers & Distribution , Stafford . A special thanks also goes to the staff of the test department at GEC Alstom , especially Mr Ross Smirthwaite , for their assistance in conducting the high voltage experimental work .

The author also expresses his gratitude to Mr D.Billington of Thorn EMI , for the provision of information and data which inspired this research . The assistance of East Midlands Electricity must also be acknowledged for the kind donation of a 50 kVA distribution transformer , which provided the foundation for the experimental work .

A special thanks is expressed to the authors supervisor , Doctor John E Newbury , B.Sc , Ph.D , F.B.I.P.S , M.Inst.P ; F.R.A.S , of the Open University , for his continued help and guidance throughout the course of this research . Thanks are also due to Mike Brant of the Open University , for the invaluable advice and help received during the programme of research .

Finally , the author would like to declare his sincere thanks to his partner , Jan , for the patience and support over the past three years .

## Memorandum

All work and ideas recorded in this dissertation are original unless otherwise acknowledged in the text or by reference . The work has not been submitted in support of an application for another degree in this university , nor for any degree or diploma at any other institution .

|  |    |
|--|----|
| <b>Abstract</b> .....                                      | 1  |
| <b>Summary</b> .....                                       | 2  |
| <b>Chapter 1. The Electricity Supply Industry</b> .....    | 4  |
| <b>1.1 Historical Background</b> .....                     | 4  |
| 1.1.1 The Pre-Nationalised Industry.....                   | 4  |
| 1.1.2 The Post War Years.....                              | 5  |
| <b>1.2 Current Architecture (pre-privatisation)</b> .....  | 6  |
| 1.2.1 Primary Distribution.....                            | 8  |
| 1.2.2 Secondary distribution.....                          | 10 |
| <b>1.3 The Politics of Ownership</b> .....                 | 14 |
| 1.3.1 The Drawbacks of a Nationalised Industry.....        | 14 |
| 1.3.2 Privatisation.....                                   | 16 |
| <b>1.4 Communications Media</b> .....                      | 20 |
| 1.4.1 Fibre Optics.....                                    | 20 |
| 1.4.2 Radio.....   | 22 |
| 1.4.3 Telephone Links.....                                 | 22 |
| 1.4.4 Power Line Carrier ( PLC ).....                      | 23 |
| <b>1.5 Architecture and Media</b> .....                    | 27 |
| <b>Chapter 2: Communication Systems and Services</b> ..... | 33 |
| <b>2.1 Load Management Services</b> .....                  | 33 |
| 2.1.1 Load Control.....                                    | 36 |
| 2.1.2 The Future of Metering Services.....                 | 37 |
| <b>2.2 Metering Systems</b> .....                          | 38 |
| 2.2.1 Multiple Tariff Rates.....                           | 40 |
| 2.2.2 The 'Intelligent' Meter.....                         | 41 |
| <b>2.3 Network Architecture</b> .....                      | 44 |
| 2.3.1 11kV Network.....                                    | 44 |
| 2.3.2 LV Network.....                                      | 48 |
| <b>2.4 PLC Protocol</b> .....                              | 49 |
| 2.4.1 Consumption Data.....                                | 50 |

|           |  |    |
|-----------|--|----|
| 2.4.2     | Tariff Data Download .....                             | 54 |
| 2.4.3     | Load Control Messages : .....                          | 56 |
| 2.5       | LV Data Rates .....                                    | 56 |
| 2.5.1     | Rural Network .....                                    | 56 |
| 2.5.3     | Semi Rural Network .....                               | 59 |
| 2.5.3     | Urban Network .....                                    | 59 |
| 2.6       | MV Data Rates .....                                    | 60 |
| 2.6.1     | Communication Architecture .....                       | 61 |
| 2.6.2     | Rural Network .....                                    | 64 |
| 2.6.3     | Semi Rural Network .....                               | 64 |
| 2.6.4     | Urban Network .....                                    | 65 |
| 2.6.5     | The Realities of a 'Pure' PLC System .....             | 66 |
| 2.7       | Summary .....  | 68 |
| Chapter 3 | The LV and MV Network as a Communications Medium ..... | 69 |
| 3.1       | Signalling Standard .....                              | 69 |
| 3.2       | The Distribution Network as a Transmission Line .....  | 70 |
| 3.2.1.    | Transmission Line Theory .....                         | 70 |
| 3.2.2.    | Standing Waves .....                                   | 71 |
| 3.3       | Elements of a Distribution Network .....               | 74 |
| 3.3.1     | Cables .....   | 77 |
| 3.3.2.    | Capacitor Banks .....                                  | 82 |
| 3.3.3.    | Voltage Regulators .....                               | 84 |
| 3.3.4.    | Lightning Arresters .....                              | 85 |
| 3.4       | Loads .....  | 86 |
| 3.4.1     | Capacitive Loads .....                                 | 86 |
| 3.4.2     | Resistive Loads .....                                  | 87 |
| 3.4.3     | Resonant Loads .....                                   | 88 |
| 3.5       | Transformers .....                                     | 91 |
| 3.5.1     | Background .....                                       | 91 |
| 3.5.2     | High Frequency Operation .....                         | 96 |

|   |     |
|---|-----|
| 3.6 Total Network Impedance .....                     | 100 |
| 3.7 Noise.....  | 102 |
| 3.7.1 Background Noise.....                           | 102 |
| 3.7.2 Smooth Spectrum Noise.....                      | 103 |
| 3.7.3 Synchronous Noise .....                         | 104 |
| 3.7.4 Non Synchronous Noise.....                      | 104 |
| 3.7.5 Impulse Noise .....                             | 105 |
| 3.7.6 Noise Summary.....                              | 105 |
| 3.8 Network Attenuation.....                          | 108 |
| 3.8.1 Attenuation Levels .....                        | 108 |
| 3.9 Summary.....                                      | 111 |
| Chapter 4: Modulation Systems .....                   | 113 |
| 4.1 Effect of Modulation and Encoding .....           | 113 |
| 4.1.1 Encoding.....                                   | 115 |
| 4.1.2 Noise .....                                     | 116 |
| 4.1.3 Modulation .....                                | 117 |
| 4.2 Analogue Modulation Schemes.....                  | 117 |
| 4.2.1 Amplitude Modulation ( AM ).....                | 117 |
| 4.2.2 Angle Modulation .....                          | 121 |
| 4.3 Pulse Modulation Schemes .....                    | 125 |
| 4.3.1 Pulse Amplitude Modulation ( PAM ) .....        | 126 |
| 4.3.2 Pulse Time Modulation ( PTM ).....              | 126 |
| 4.3.3 Pulse Code Modulation ( PCM ) .....             | 128 |
| 4.3.4 Comparisons of Pulse Modulation Systems.....    | 129 |
| 4.4 Digital Modulation Systems.....                   | 130 |
| 4.4.1 Amplitude Shift Keying ( ASK ).....             | 131 |
| 4.4.2 Frequency Shift Keying ( FSK ).....             | 132 |
| 4.4.3 Phase Shift Keying ( PSK ).....                 | 134 |
| 4.4.4 Comparisons of Digital Modulation Systems ..... | 136 |
| 4.5 Spread Spectrum Modulation .....                  | 137 |



|  |            |
|--|------------|
| 4.5.1 General Characteristics.....                       | 138        |
| 4.5.2 Interference Rejection.....                        | 138        |
| 4.5.3 Spread Spectrum Variants.....                      | 139        |
| 4.5.4 Direct Sequence Spread Spectrum.....               | 140        |
| 4.5.5 Frequency Hopping Spread Spectrum.....             | 141        |
| 4.5.6 Chirp Spread Spectrum.....                         | 142        |
| 4.5.7 Hybrid Systems.....                                | 143        |
| 4.5.8 Relative Merits of Spread Spectrum Systems.....    | 144        |
| 4.6 Ultra Narrowband.....                                | 146        |
| 4.6.1 Ultra Narrowband as a PLC.....                     | 146        |
| 4.7 Low Frequency Techniques.....                        | 148        |
| 4.7.1 Uni-directional Systems.....                       | 148        |
| 4.7.1 Bi directional Systems.....                        | 148        |
| 4.8 PLC Modulation: The Trade-offs.....                  | 149        |
| 4.8.1 Degree of Service.....                             | 150        |
| 4.8.2 System Robustness.....                             | 150        |
| 4.8.3 System Architecture.....                           | 151        |
| 4.8.4 System Economics.....                              | 152        |
| 4.9 Summary.....   | 153        |
| <b>Chapter 5 Experimental Work.....</b>                  | <b>155</b> |
| 5.1 Introduction.....                                    | 155        |
| 5.2 Transformer Signalling Modes and Configurations..... | 156        |
| 5.2.1 Preliminary Investigations One.....                | 159        |
| 5.2.2 Preliminary Investigations One - Conclusions.....  | 163        |
| 5.3 Coupling Circuits.....                               | 165        |
| 5.3.1 Preliminary Investigations Two.....                | 165        |
| 5.3.2 Preliminary Investigations Two - Conclusions.....  | 167        |
| 5.4 11kV and 415V Coupling.....                          | 168        |
| 5.4.1 Low Voltage Coupling.....                          | 168        |
| 5.4.2 Medium Voltage Coupling.....                       | 172        |

|   |            |
|---|------------|
| 5.5 Through Transformer Signalling Bands.....                                 | 174        |
| 5.5.1 Non Coherent and Coherent Narrowband.....                               | 174        |
| 5.5.1.1 Signalling Levels.....  | 177        |
| 5.5.1.2 Experimental Work One: Unenergised Passbands .....                    | 179        |
| 5.5.1.3 Experimental Work One - Findings .....                                | 189        |
| 5.5.1.4 Experimental Work Two: Energised Passbands .....                      | 198        |
| 5.5.1.5 Experimental Work Two - Findings .....                                | 203        |
| 5.5.2 Non Coherent and Coherent Wideband.....                                 | 211        |
| 5.5.2.1 Non Coherent Wideband.....  | 211        |
| 5.5.2.2 Experimental Work Three - Chirp Systems.....                          | 218        |
| 5.5.2.3 Experimental Work Three - Findings .....                              | 225        |
| 5.5.2.4 Coherent Wideband .....   | 227        |
| 5.6 Summary.....  | 239        |
| <b>Chapter 6 Conclusions.....</b>   | <b>240</b> |
| 6.1 Architecture / Data Rates .....   | 241        |
| 6.2 Transformer Frequency Response.....                                       | 241        |
| 6.3 Data Rates / Service .....  | 244        |
| 6.4 Enhanced Performance.....   | 245        |
| 6.5 System Economics .....  | 247        |
| 6.6 Further Work .....  | 248        |
| <b>References:.....</b>   | <b>250</b> |
| <b>List of Figures and Tables.....</b>  | <b>262</b> |
| <b>Abbreviations and Symbols.....</b>   | <b>268</b> |
| <b>Appendix A: 50kVA Transformer Characteristics.....</b>                     | <b>272</b> |
| <b>Appendix B: Transformer Frequency Characteristics ( Unenergised ).....</b> | <b>280</b> |
| <b>Appendix C: Transformer Frequency Characteristics ( Energised ).....</b>   | <b>300</b> |

## Abstract

In the wake of the governments 1989 Electricity act , privatisation reforms have urged the Electricity Supply Industry to enhance the capabilities of its current communication infrastructure . With this realisation , the possibilities of using the industries own distribution network as a communication medium has become a serious proposition . Although this may seem an innovative solution , the use of electrical distribution feeders for conveying information is not in fact new .

However , recent advances in technology have provided solutions to the outstanding problem of attaining 'usable' data rates in the harsh power line environment . With this in mind , a powline telecommunications network seems a viable option for the electricity distribution companies . Unfortunately , a system which utilises both LV and MV networks remains presently unattainable , due to the unknown characteristics of the distribution transformer . Having highlighted the need to develop a 'through transformer' signalling system , the frequency characteristics of the distribution transformer have become of paramount interest .

Although spread spectrum systems are gaining widespread acceptance , the high process gain required in adverse communication environments mitigates against high data rates . Investigations have demonstrated that an alternative strategy of lower frequency techniques is capable of maintaining a comparable integrity of communications .

The following work catalogues the results and draws conclusions from research devoted to an investigation into the propagation of PLC frequency signals through distribution type transformers . From this analysis the viability of a 'through transformer' architecture may be assessed .

## Summary

The work contained in this thesis commences with a review of the Electricity Supply Industries structure in both its nationalised and privatised state . Aspects of the 1989 Electricity act which concern the introduction of second tier supply , for all consumers , are then discussed . The requirement of a sound communications architecture which will cope with the Electricity Supply Industries needs is then made apparent . With this in mind several communication architecture's are examined , placing particular emphasis on the use of power distribution feeders as a communications medium , using a 'through transformer' architecture .

Following this initial review , an outline of present and future remote metering systems and services is provided . A study of the 11kV / 415V distribution network is then made , which provides a basis to calculate anticipated network data rates for the provision of remote metering services .

A literature survey is then presented which summarises the research undertaken by several sources , concerning the characteristics of the LV and MV power distribution network as a communications medium . From this review conclusions are drawn which highlight the lack of research devoted to the distribution transformers through signalling characteristics .

In a prelude to experimental investigations a study of modulation techniques is made . This analysis pays particular attention to the modulation techniques which are particularly appropriate for use as a power line carrier .

With the 'ground work' of the thesis now completed , the methodical approach of the experimental work is presented . The experimental work investigates the frequency response of a cross section of distribution transformers over the frequency range reserved for PLC signalling (  $\approx 3\text{kHz}$  to  $150\text{kHz}$  ) . The experimental work covers energised

(powered up ) tests , undertaken at GEC Alsthom Stafford and unenergised tests carried out at GEC and John Moores University , Liverpool .

Having investigated the distribution transformers response at PLC frequencies , an analysis is made of the effect which the transformers' propagation characteristics have on various modulation schemes . From this analysis the trade-offs are examined between the achievable signal data rate , required bandwidth and system complexity / cost .

# **Chapter 1. The Electricity Supply Industry**

## **1.1 Historical Background**

As the population and industrial capacity of the United Kingdom dramatically increased following the days of the industrial revolution, so did the need to transfer energy from one site to another. This factor is most evident in the case of electricity, one of the most convenient and widely used form of energy.

One of the advantages of using electricity as a fuel is its ability to be quickly and efficiently changed from one voltage to another. This permitted economical transfer of energy from generation point to the consumers load, and hence outlined the need for an electricity distribution network.

Before analysing the current electricity distribution network architecture it is appropriate to trace its evolution over the years [92].

### **1.1.1 The Pre-Nationalised Industry**

The widespread use of electricity as a potential fuel was firstly addressed by the Electric Lighting Act of 1888. This act allowed the Board of Trade, with the consent of local authorities, to authorise the supply and distribution of electricity by private companies. Although this paved the way for an electricity distribution network, the technology did not yet exist to implement the widespread distribution of electricity.

At the time of the 1888 act many companies had adopted direct current (d.c) supply and distribution systems. Due to the low voltage, high current nature of these systems, transmission beyond a certain distance proved uneconomical. This was primarily because of the  $I^2R$  losses associated with high current transmission. The need

for a high voltage , low current , transmission and distribution system was apparent . At the time high voltage transmission had already been demonstrated by Ferranti using an alternating current ( a.c ) system with transformers . Despite this possible solution many companies refused to change from d.c supply . In fact many d.c systems lasted well into the 20th century up until the 1920's .

The realisation that the economics of electricity transmission necessitate higher voltages , for the transmission of higher power over greater distances , led to the Electricity Act of 1926 .

Although as early as 1910 voltages up to 100kV ac were used for transmission , the Electricity act of 1926 provided for a grid system to standardise the transmission voltage at 132kV ac . The grid was to be owned by the Central Electricity Board and was designed to interconnect selected generating stations . This allowed the pooling of generation plants to enable a more efficient generation and distribution of electricity . The results of this reorganisation was a drop in the average cost of generation .

### **1.1.2 The Post War Years**

In the years following the 2nd world war ( 1939 to 1945 ) the ever increasing demand for electricity had made the 132kV grid system inadequate . This , together with the need for reorganisation following the years of war , led to the government nationalising the electricity supply industry in 1948 . Nationalisation placed all the generation , transmission , and distribution under one authority named the 'British Electricity Authority' . One of the main outcomes of the nationalisation strategy was the construction of the 'Supergrid' , designed to operate at 275kV . The supergrid had the capacity for bulk transmission which meant that generating stations could be built on the most economic sites thus enabling cheaper generation of electricity .

The next major change in the industry came in 1965 when the decision was made to uprate the grid to 400kV in order to accommodate with the rising demand . From the 1960's up to the early 1970's the Central Electricity Generating Board ( CEGB ) underwent considerable expansion . With the construction of new power stations , including the nuclear programme , came more transmission cables , transformers , overhead and underground distribution cabling together with additional substations .

## **1.2 Current Architecture (pre-privatisation)**

At present the Electricity Supply Industry may be split into three functional areas , that of generation , transmission , and distribution . Referring to Fig 1.1 , generators are placed at strategic sites such as coal producing areas , river estuaries and coastal sites . The generators produce electricity at voltages from 11kV to 33kV . Step up transformers then increase the voltage to 275kV or 400kV ( box 1 in fig 1.1 ) for the purposes of bulk transmission over the grid or 132kV ( box 2 ) for transmission to local suppliers .

The transmission voltage is then stepped down to its distribution level of 33,000V ( box 3 ) . At this point the supply may be directed to specific types of load . Heavy industry may be supplied directly at 33,000V ( 7 in fig 1.1 ) whilst electric railways receive a 25,000V supply via step down transformers ( box 6 ) . The remaining 33,000V supply lines are stepped down to 11,000V . This occurs at primary substations ( 4a , 4b and 4c ) . Primary distribution feeders then directly supply light industry and hospitals ( 8 ) or are stepped down to 415V / 240V for the supply of domestic consumers or light commercial customers . The step down to 415V / 240V occurs at distribution substations ( 5 ) .

It is the distribution system which is of most interest at this stage so particular attention will be paid to the networks various architecture's .



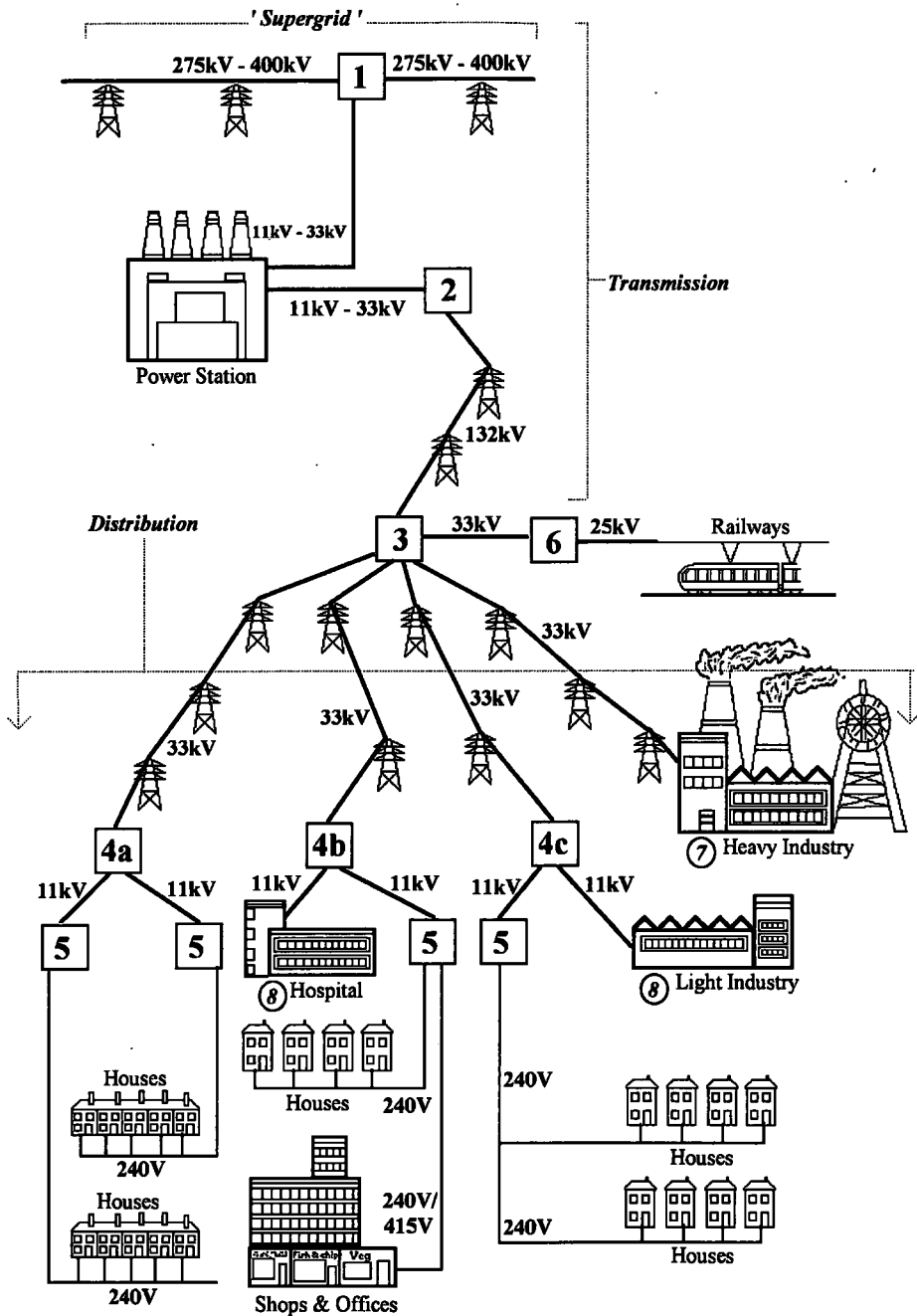

Fig 1.1: The Electricity Supply Industry .

The distribution system may be split into two networks , that of Primary distribution ( 33kV , 11kV and in some cases 6kV ) and that of Secondary distribution ( 415V and 240V ).

### 1.2.1 Primary Distribution

Three basic types of primary distribution systems are used .

- i. Radial systems .
- ii. Loop system .
- iii. Primary network system .

i. Radial systems: This type of system is the most simplest and probably the most common system used . Referring to Fig 1.2 , the system consists of separate feeders radiating out from the substation , each serving a given area . Connected to the main 'trunk' feeders are lateral feeders which in turn serve the distribution transformers .

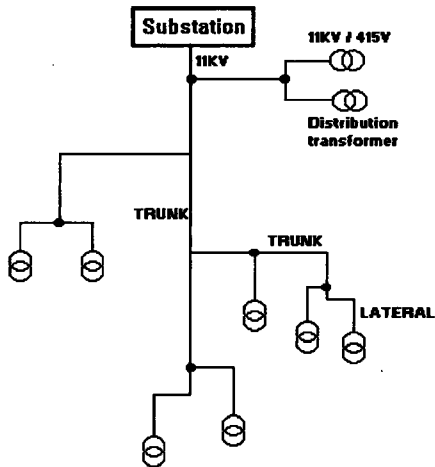

Fig 1.2: Radial System

ii. Loop systems: One of the main disadvantages of the previous radial system is that of supply interruption due to main feeder / substation faults . Loop systems avoid this by providing a two way primary feed . Should the supply from one direction fail , the entire load of the feeder may be carried from the other end . Fig 1.3 illustrates this system .

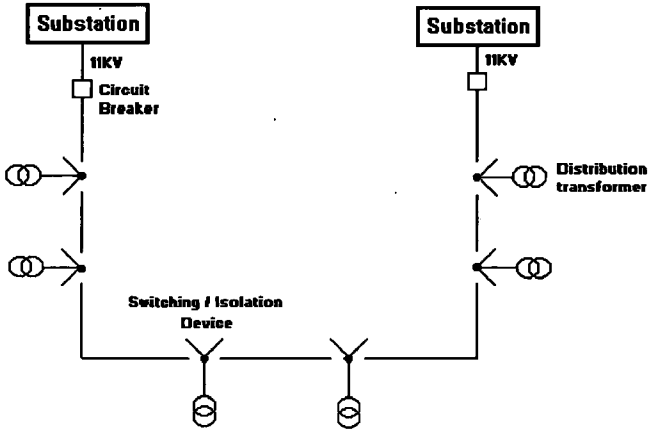

Fig 1.3: Loop System

Here the section of primary feed under fault conditions may be isolated to enable repair whilst the remainder of the feeder can remain energised .

iii. Primary Network systems: This system is formed by interconnecting radial systems to form a mesh or grid . As the primary feeders are fed from both ends faults may be isolated or feeders may be sectionalised . This results in minimum interruption of supply and is illustrated in Fig 1.4 .

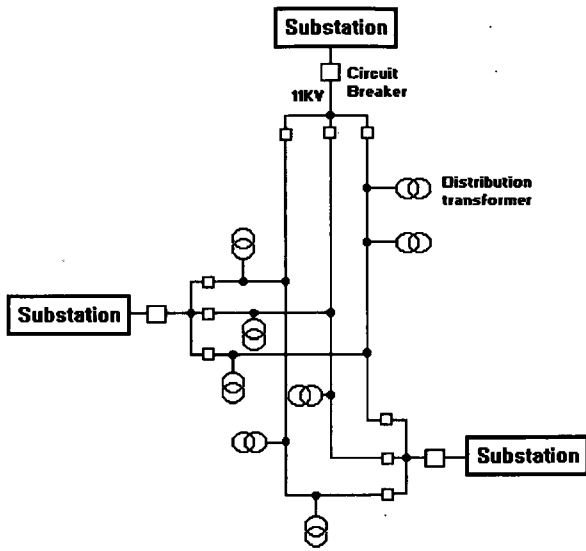

Fig 1.4: Primary Network Systems

### 1.2.2 Secondary distribution

Four basic types of secondary distribution are commonly used .

- i. Individual transformers .
- ii. Common secondary main .
- iii. Continuous secondary main .
- iv. Grid network .

i. Individual transformers: This maintains one consumer to one transformer . This type of secondary distribution is generally implemented in rural areas where consumers are far apart and long secondary mains are impractical , or where a consumer has an unusually large load .

ii. **Common Secondary main:** In this system one transformer serves a group of consumers . It is perhaps the most common type of secondary system . Fig 1.5 illustrates this type of system . Here the strain insulators allow the secondary mains to be cut into sections . As loading conditions change these points may be moved in order to distribute the load more evenly .

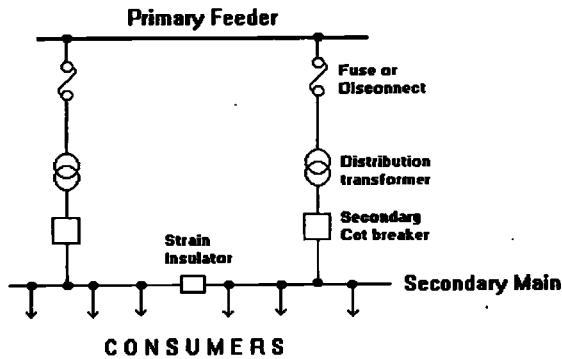

Fig 1.5: Common Secondary Main

iii. Continuous Secondary Main: Also known as the 'banking' of transformer secondaries . This system may be viewed as a primary feeder to which a long section of secondary feeder is connected via distribution transformers . Its architecture is very similar to the common secondary main but with strain insulators omitted . This system provides the advantage of uninterrupted supply should a transformer fail .

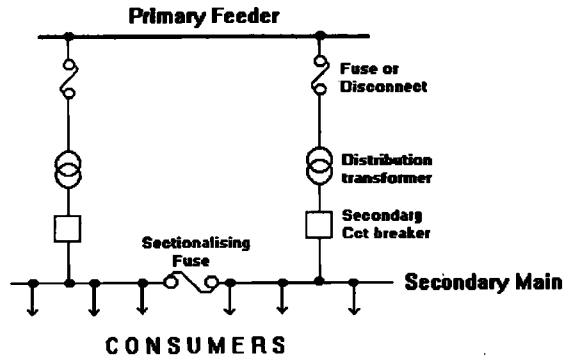

Fig 1.6: Continuous Secondary Main

iv. Grid Network: Although the most costly to implement , this type of architecture provides the highest degree of reliability and is suited to areas of high load density . Referring to Fig 1.7 , the network is created by connecting together the secondary mains fed from transformers supplied by two or more primary feeders . In this system a number of transformers / links must fail before supply is interrupted .

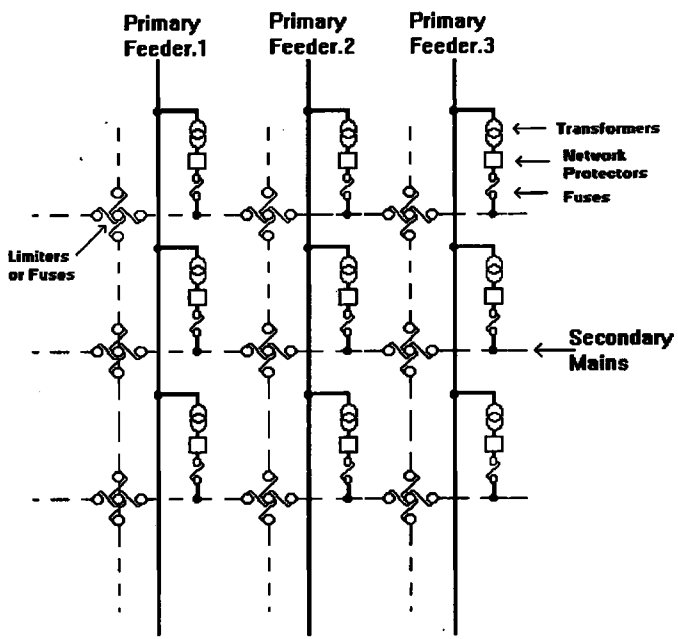

Fig 1.7: Grid Network

### **1.3 The Politics of Ownership**

With the Electricity Supply Industry operating in its nationalised state the structure of ownership was as follows .

The Central Electricity Generating Board ( CEGB ) owned and controlled the generating stations together with the National Grid , used for bulk transmissions of power. It was the responsibility of twelve independent area electricity boards to distribute electricity from the high voltage grid , through their lower voltage distribution networks , to the consumers . The twelve area boards are distributed geographically in the manner shown in fig 1.8 .

Unfortunately the structure of the Electricity Supply Industry in its nationalised state suffered several inherent drawbacks .

#### **1.3.1 The Drawbacks of a Nationalised Industry**

In the years prior to privatisation the Electrical Supply Industry operated within a legislative framework which meant that the most important investment decisions were effectively made by a monopoly supplier . With the industry configured in such a way the paying customers had little say or influence on industry policy .

Changes in government policy in the 1980's , together with the technological advances and need for reinvestment throughout the electrical generation and distribution industries , brought about the need for a new strategy within which the industries could operate . This led to the government presenting a white paper [84] which outlined its proposals for the privatisation of the electrical supply industry in England and Wales .



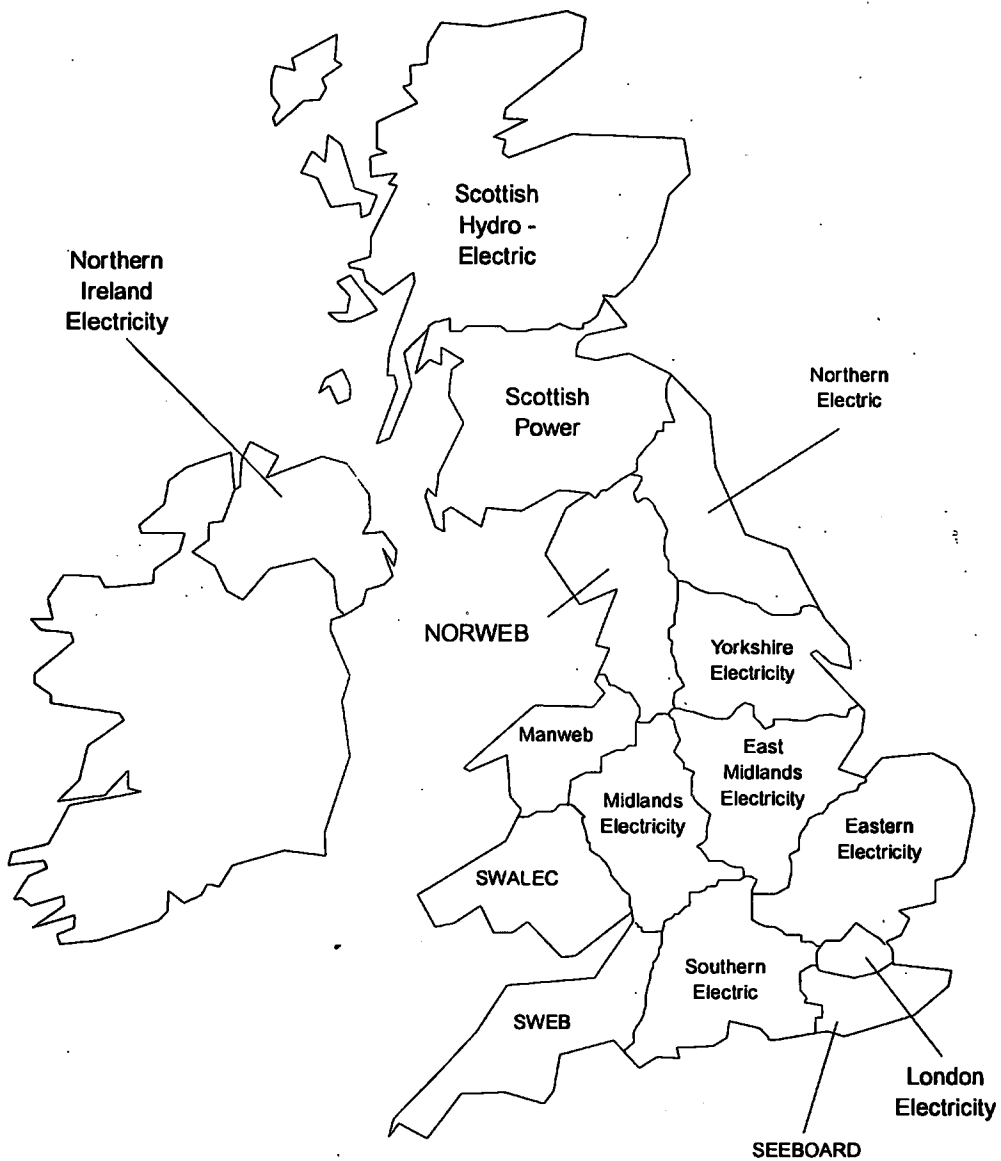

Fig 1.8: The twelve area Electricity Boards .

It was the governments intention to end the effective monopoly of the CEGB ( Central Electricity Generating Board ) in generation , by introducing competition , and give more influence to the distribution companies and their customers .

In order to ensure a secure , uninterrupted supply of electricity , the CEGB has a statutory obligation to provide bulk supplies of electricity to the area boards . Unfortunately this obligation has led to several disadvantages .

- Because the CEGB must be sure of generating enough electricity to meet its obligation , it alone determines the number and type of power stations needed .
- In order to be sure of delivering electricity to meet its obligation , the CEGB must own and control the national grid . This discourages potential competition .

In its nationalised state the CEGB relied on demand forecasts to predict its generation requirements , thus meeting its statutory obligation . Unfortunately these demand forecasts are not entirely accurate and consequently lead to over production and sometimes underproduction . In these cases the former results in waste , leaving the customer to pick up the costs , and the latter results in standby power stations having to be brought on line , this also being a costly procedure .

### **1.3.2 Privatisation**

It was the governments intention that privatisation of the Electrical Supply Industry would introduce technologies which would permit demand side management and load profiling to take place . This would allow the CEGB to generate electricity more efficiently , thus reducing costs to customers .

In 1988 the government presented a white paper which outlined its plans for privatisation . The main areas of reorganisation were as follows .

- i) The twelve area boards will be privatised as twelve distribution companies , each obliged to supply its own area .
- ii) The national grid will remain and retain its central role .
- iii) The CEGB's effective monopoly will be ended .
- iv) The CEGB's obligation of supply will be ended .
- v) An effective system of regulation ( *offer* ) [85] will be set up .

It is hoped that the competition introduced by this reorganisation will provide an incentive to promote competition in generation . This will result in more efficient generation of electricity which will not only bring about financial benefits , but will also benefit the environment .

### **Customer benefits**

From a customers viewpoint it is intended that privatisation will produce the following benefits .

- ◆ Customers should have a choice between suppliers .
- ◆ Suppliers will be able to offer a greater variety of contracts and tariffs . ( e.g. half hourly electricity tariffs )
- ◆ Customers should be able to understand and control their use of electricity more effectively .
- ◆ Generation stations and transmission lines are only built when and where customers really need them

The right of the customer to have a choice of suppliers , known as 'second tier supply' , has been given a definite timetable for implementation . This timetable has been detailed in the 1989 Electricity act . Its schedule for introducing second tier supply is as follows [87] .

- ♦ The above 1MW market \_\_\_\_\_ 1st April 1990
- ♦ The above 100KW market \_\_\_\_\_ 1st April 1994
- ♦ The under 100KW market \_\_\_\_\_ 1st April 1998

The prospects of introducing second tier supply will now be discussed .

**The Above 1MW market:**

At the present time second tier supply has been available for the above 1MW market for nearly six years . This market consists of around 4,600 sites , all of which are now entitled to half hourly metering . Data from these half hourly meter readings is collected by telephone links , radio communication , or in some cases manually . For this entitlement several costs are incurred , namely , the capital cost of metering equipment , the provision of data acquisition and communication equipment and the expenses of site installation , commissioning and maintenance . These costs , together with a 'second tier system' charge ( for customers opting for second tier supply ) add up to a substantial figure at present . However , it is believed that increased competition in future years will reduce these costs and that the financial benefits of second tier supply will offset the second tier system charge .

**The Above 100kW market:**

In the above 100kW market second tier supply has been available for almost two years . This market consists of around 47,000 customers , thus forming a significant increase in the number of second tier customers . The financial benefit to be gained by these medium sized customers by opting for second tier supplies is less than that of the above 1MW market . Consequently , these customers will be more sensitive to the costs of metering and communication systems .

One of the main problems associated with the above 100kW market is the increase in the volume of data which must be transmitted and processed . To reduce this problem it has been suggested that local data collection systems may be used as opposed to secondary data collection systems .

#### **The Under 100kW market: [88]**

This market consists of all 22 million electricity consumers including domestic customers . It is these customers who are likely to be even more cost sensitive than the over 100kW customers when it comes to the price of metering equipment . Metering charges based on the 'older' technologies associated with the above 1MW market would be too costly to make second tier supply a viable financial option for domestic customers . Previous methods of data collection would also be unable to cope with the massive increase in the volume of data . These factors call for a new approach to meter reading and data transmission / processing .

**Modern metering systems must have the following characteristics .**

- i) A facility must be available to register , store and process larger quantities of data .
- ii) Meters must be able to send and receive a wide variety of messages .
- iii) A cost effective transmission media for the communications channel .
- iv) A user friendly interface for the customer .
- v) An ability to provide future services such as load control etc.

Above all though modern metering systems must be able to justify their initial cost and maintenance costs by the financial savings they bring to the consumer as well as the industry .

One of the main contributors to the cost of operating a modern metering system is that of data collection . By the very nature of the data involved it becomes apparent that

data collection by conventional means is not viable . A form of automatic , remote meter reading is required . If second tier metering , together with services such as distribution automation and load profiling are to be introduced , it is clear that the area electricity boards must develop a sound communications infrastructure .

Several methods of communication using a wide variation in technologies have been tried and tested and are in use today . The next section of this chapter will briefly discuss the relative merits of these different technologies paying particular attention to using the electrical distribution network as a communications medium .

## **1.4 Communications Media**

In order to establish a communications network , area electricity boards have considered various forms of communications media , some of which provide established forms of monitoring and protection [89] . This next section will explore the advantages and disadvantages of the common types of media used .

### **1.4.1 Fibre Optics**

Due to their increasing levels of performance and declining cost widespread installation of fibre optics is being undertaken by many telecommunications utilities [90] . One of the most cost effective methods of installation is currently being explored by the power supply industry . With the fibres' natural immunity to electromagnetic fields , installation alongside existing overhead high voltage supply and distribution networks seems a viable solution to the industries communications needs .

Currently many power utilities are installing optical fibre cables on their high voltage lines [57],[58],[59],[93] Several methods of installation are practised .

- i. Optical ground wire: Here the optical fibres are contained within the core of a conventional ground wire .
- ii. 'Wrapped' cable: In this method the optical cable is wrapped around either the phase or earth conductor of an existing system .
- iii. Self supported cable: This is perhaps the most innovative method as installation may be performed on a live network . The fibre optic cable is completely independent of the phase / earth conductors and is mechanically strong enough to be self supporting .

Amongst optical fibres' advantages are:

- ◆ Its low attenuation rate , typically better than 0.5 dB / km . This results in greater distances between repeater spacing , typically 30 to 80 km depending upon the data rate .
- ◆ Very high data rates ( up to 10 Mbits / sec ) , hence lines may be leased to other telecommunications utilities .
- ◆ As a communications system fibre optics may easily be integrated into any digital network at minimum cost .
- ◆ A high immunity to electromagnetic interference together with minimum susceptibility to lightning and earth faults .

Installation of fibre optic cabling on the high voltage lines of the power supply industry seems to provide the industry with an economic means of obtaining a communications network . Unfortunately at the present time it does not seem feasible to extend this network onto the lower voltage distribution system . With this in mind a comprehensive fibre optic network which extends to every consumer and provides services such as remote metering and load control is not likely in the near future . A more realistic application of fibre optics probably lies in a hybrid communications system which combines fibre with radio or with power line carrier ( PLC ) . These hybrid architecture's will be discussed in greater detail later .

### **1.4.2 Radio**

Due to the high initial costs of installing more permanent communication links such as telephone and fibre optic cable , radio can provide a cost effective alternative . This is particularly so in rural isolated areas where the cost per consumer for installing permanent links is high .

Several established methods of providing remote metering services using radio links are in widespread use . These range from using short range radio to read the consumers' meter from a mobile vehicle [60] to more complicated load profiling and load management schemes using a permanent transmitter and radio teleshwitches [61] .

For one way transmissions and low data rate services radio seems to provide the answer to the electricity supply industries communications needs [102] . Unfortunately , for more complex services which require two way transmissions with higher data rates , an already crowded frequency spectrum restricts the available bandwidth [98] . This together with the strict controls imposed over frequency band allocation perhaps inhibits radio from providing future metering services which the consumer will demand .

Yet again a compromise may be for the industry to adopt a hybrid architecture [86] which will allow the advantages of radio to be combined with the benefits of other media .

### **1.4.3 Telephone Links**

Currently the electricity supply industry uses the Public Switched Telephone Network ( PSTN ) for purposes such as teleprotection . This gives utilities the ability to perform remote switching operations in its substations using an established readily available media . Although the PSTN reaches most consumers and exhibits a high degree of availability , with high data rates , it must be leased from a third party . This factor has



discouraged utilities from using the PSTN as a communications link to the consumer . Presently the industry combines PSTN links with other technologies such as power line carrier in order to minimise the cost of line leasing .

#### **1.4.4 Power Line Carrier ( PLC )**

The fundamental difference between PLC and all other media ( perhaps apart from radio ) is that it is a media which presently reaches every consumers' home . In addition the fact that the utility actually owns the media , therefore leasing is unnecessary , makes the use of PLC particularly attractive .

In contrast to these advantages , PLC suffers from some drawbacks . Amongst its limitations are;

- ◆ The cabling was designed specifically for high voltage 50Hz power transmission . The cable construction and layout does not favour the propagation of medium frequency , low power signals .
- ◆ The noise associated with the energised power cable ( random noise and burst noise generated by fault conditions ) makes the power line environment extremely hostile . Consequently low levels of signal to noise ratio are encountered , therefore causing high levels of attenuation .
- ◆ A loss of power , due to interruptions in supply , also means an interruption in communications path .
- ◆ The varying nature of loads causes differing levels of network impedance across the frequency spectrum which hinders signal propagation .
- ◆ The presence of transformers , capacitor banks , and line traps also limits signal propagation . Although this may well be seen as an advantage in some cases , depending upon topology and architecture of the communications system .

- ◆ Because of potential radiation from overhead lines a limitation on carrier signal frequency has been imposed . Currently its upper limit is set at  $\approx 150\text{kHz}$  . This factor causes limitations in available bandwidth and hence reduces possible data rates .

Although these drawbacks may seem to be severe enough to rule out the use of PLC systems , the problems associated with the powerline can and have been overcome . It is perhaps relevant at this stage to introduce some of the more early , simple forms of PLC which have been proved .

### **Cyclocontrol:**

Cyclocontrol is perhaps one of the earliest widespread forms of powerline carrier signalling . It was devised by the London Electricity board and involves the short circuiting of the low voltage 50Hz power wave for a brief period near its zero crossings [62] . Fig 1.9 shows the magnified zero crossing of the 50 Hz wave . This distortion is actually very small so that interference with other equipment on the mains is unlikely . In order to form a message a short circuit pulse is either applied , to form a data '1' , or not applied to form a data '0' . Over a number of cycles a 'word' is transmitted which consists of 50Hz bits .

This particular form of signalling has good propagation characteristics and will propagate through the distribution transformer . Unfortunately , by the very nature of the signal , its use is limited to applications which involve particularly low data rates .

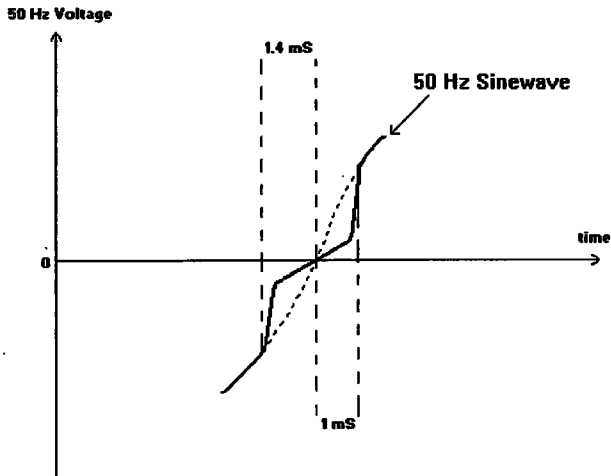

Fig 1.9: Cyclocontrol

### Ripple Control:

The use of ripple systems is a tried and tested means of power line carrier communication dating back to the early half of this century [77]. It is primarily used for implementing load and management programs using one way transmissions consisting of audio frequency control impulses which are superimposed on the network voltage at one or more central points.

At the transmitter, signals are generated by a device known as a 'static frequency converter' whose operation is as follows. Mains power is drawn from the network, then rectified. The d.c voltage is then 'chopped' to a square wave of the required frequency by a thyristor control unit. This frequency is in the audio range between 110Hz and 750Hz. A coupling circuit then 'superimposes' the audio signal onto the network voltage. The audio frequency voltage output level may be adjusted at times of extreme load conditions. A message is encoded by the time difference between a start impulse and one or more impulses during a 25 second duration of transmission. The audio frequency impulses can be transmitted at a total of 50 different and distinct time stages, hence 50 information elements are available for one message.

At the receiver a narrowband bandpass filter couples the audio signal to a 'decoder' which interprets the received signal from a 'library' of possible messages . Appropriate action is then taken . The narrowband nature of the receiver input filter permits utilisation of the frequency range between network voltage harmonics by several transmitters .

With the ability to be connected to voltages ranging from 220V to 138kV , ripple systems are versatile and robust with good propagation characteristics ( through transformer propagation ) . Unfortunately as with Cyclocontrol it inherently suffers from low data rates with scope only for one way transmissions .

Although Cyclocontrol and Ripple control , [75] , are tried and tested methods of power line carrier signalling , their uses are limited . The transmitters power consumption restricts their use to one way transmissions from a central transmitter to a large number of receivers . In addition , their low data rates would render them impractical for the amount of data today's power line signalling systems would be expected to handle .

In the past , technologies have existed which would overcome the problems associated with power line carrier , but they have not been economical to implement . However , with advances and reductions in production costs of VLSI technology , recent years have seen the emergence of practical , economical power line signalling systems .

It is intended to introduce and discuss these 'newer' technologies in chapter 2 .

At this point it is perhaps appropriate to look at how the distribution networks' layout could support various communications architecture's .

## 1.5 Architecture and Media

In order to establish a remote metering and load control system , differing architecture's and media have been used . The basic aim of these systems is the transfer data between a central point sited at the utilities headquarters and remote terminal units ( RTU's ) located at the consumers premises .

### i. PLC and PSTN :

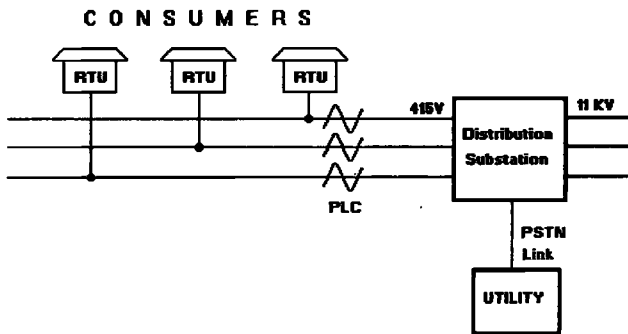

Fig 1.10: PLC and PSTN

Fig 1.10 illustrates how a power line carrier system operating on the low voltage ( 415V ) distribution line feeders provides two way communications up to the distribution substation . At this point the signal is coupled to the PSTN lines which provide a direct link to the utilities control centre .

This is perhaps the most common way of providing a bi-directional communications link between utility and consumer . It suffers from the drawback that the PSTN link must be leased from a third party .

The economics of implementing this type of architecture are dependant upon the number of consumers which the distribution substation serves . In densely populated urban city areas such as 'tower block' flats and offices , where one distribution transformer serves hundreds of consumers , it may be economically feasible to lease the PSTN link . On the contrary in semi rural areas , where one distribution transformer provides supply for less than 10 consumers , it may be uneconomic to install and lease PSTN links . Basically , in order to justify the lease of PSTN links , the ratio of consumers per distribution transformer must be relatively high .

**ii. PLC and Fibre Optics:**

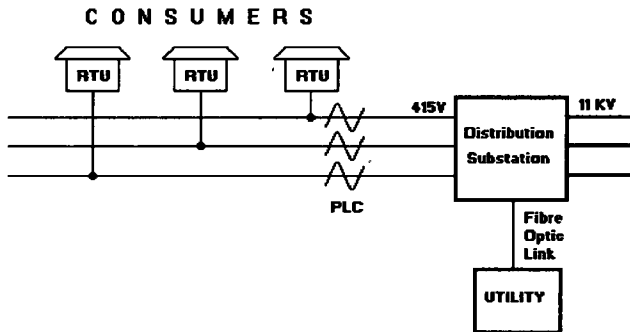

**Fig 1.11: PLC and Fibre Optics .**

In Fig 1.11 the use of PLC on the low voltage feeders is similar to that of Fig 1.10. From the distribution substation to the utility fibre optic cabling is used for the communications link . The use of fibre optics eliminates the need to lease the PSTN lines , but presently the cost of installing fibre optic cabling to every distribution substation is relatively high . The economics of this system architecture are similar to the ones of fig 1.10 .

iii. PLC ( Substation bypassed ):

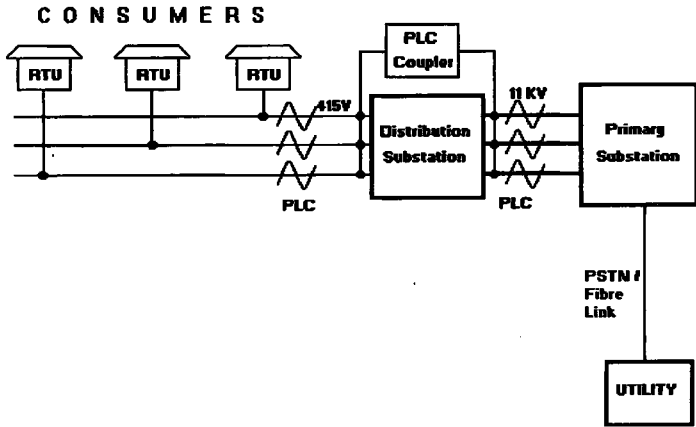

Fig 1.12: PLC bypassing the distribution substation .

This architecture eliminates the necessity to install PSTN or fibre optics to every distribution substation . With the utility now linked directly to the primary substation the number of PSTN / fibre optic lines required is substantially reduced .

To achieve this , use is made of the 11kV feeders for PLC signalling . The signal is transferred from the low voltage ( 415V ) to the medium voltage ( 11kV ) via a coupling unit installed in the distribution substation . Even though the leasing and installation of PSTN / fibre links to every distribution substation no longer enters into the economics of the system , the number of consumers per distribution substation must be relatively high , in order to justify the installation of a coupling unit at every distribution substation .

#### iv. PLC - Through Transformer Signalling:

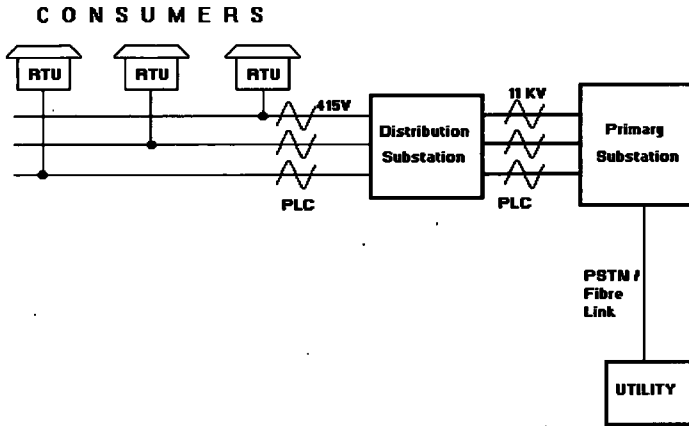

Fig 1.13: Through transformer signalling .

With the previous system the main disadvantage lies in the need to install low voltage to medium voltage coupling units in every distribution substation . The system architecture of Fig 1.13 would utilise modulation and encoding techniques which could propagate the power line carrier through the substation transformer .

The architecture of this system implies that it is particularly suited to rural distribution networks where the isolated nature of distribution transformers make PSTN / fibre link installation uneconomic . Also in rural networks the ratio of consumers per transformer is quite low , thus the number of distribution transformers is greater . Therefore the installation of coupling units on every transformer would be uneconomic .

Although this system is mainly suited to rural networks , it would be desirable to apply this system to all types of distribution networks from urban to rural .

From the utilities viewpoint the architecture of fig 1.13 is the most desirable of the ones discussed so far . Unfortunately , at the present time , no practical system has been successfully perfected and marketed .



The absence of such a system leaves a gap in the field of power line signalling systems . With this in mind the issue of through transformer signalling has become of paramount interest to many utilities and developers of PLC products .

In a bid to help fill this 'gap' of knowledge the following research looks more closely at the way distribution transformers modify the propagation of signals .

Firstly it is appropriate to introduce the direction which the research followed . This may be accomplished by a review of the subsequent chapters .

Chapter 2 will look at the services which present remote metering systems have brought , together with possible future developments . An investigation will then be made into the data rates required to support such systems and services with respect to the architecture of the distribution system .

In chapter 3 the characteristics of the low voltage and medium voltage distribution networks as a communications medium will be investigated . The effect which loads , cable types and network architecture have on the propagation of signals will be examined.

With the characteristics of the distribution network in mind , chapter 4 will review modulation techniques , whilst drawing attention to the schemes most suited as PLC's .

Chapter 5 will provide a detailed description of the methodical approach of the experimental work undertaken at John Moores University ( Liverpool ) and GEC Alstom Stafford . An analysis of the results will also be provided , which may then be integrated with the conclusions drawn from earlier chapters .

A point has now been reached where the research may be concluded . The work undertaken in this research programme will be reviewed in chapter 6 . Conclusions may be drawn to establish what services may be possible and economically justifiable using a power line carrier communication system . A programme of future work will then be put forward which may augment the studies undertaken in this research .

## **Chapter 2: Communication Systems and Services**

Having introduced the structure of the electricity supply industry , together with various communications architectures , it is now appropriate to discuss the services which may be provided by such a communications infrastructure .

Before looking more closely at the services these communication systems will bring , the driving force behind these services must be considered .

### **2.1 Load Management Services**

Until recent years power stations have generated enough electricity to meet the demands of the consumer . This was accomplished by analysing the past trends of electricity consumption so that the supply companies had an approximate idea of when and how much electricity would be required . As discussed in chapter 1 , this was not the optimum way to operate a generation plant . It has always been preferable , from the suppliers viewpoint , for the customer to consume more electricity at 'off peak' times and less electricity at 'peak' times [97] .

The reasoning behind this approach is for the generation plant to obtain a 'flatter' daily load profile , thus improving the load factor ( the difference between peak and off peak values of load ) . This is shown in fig 2.1 .

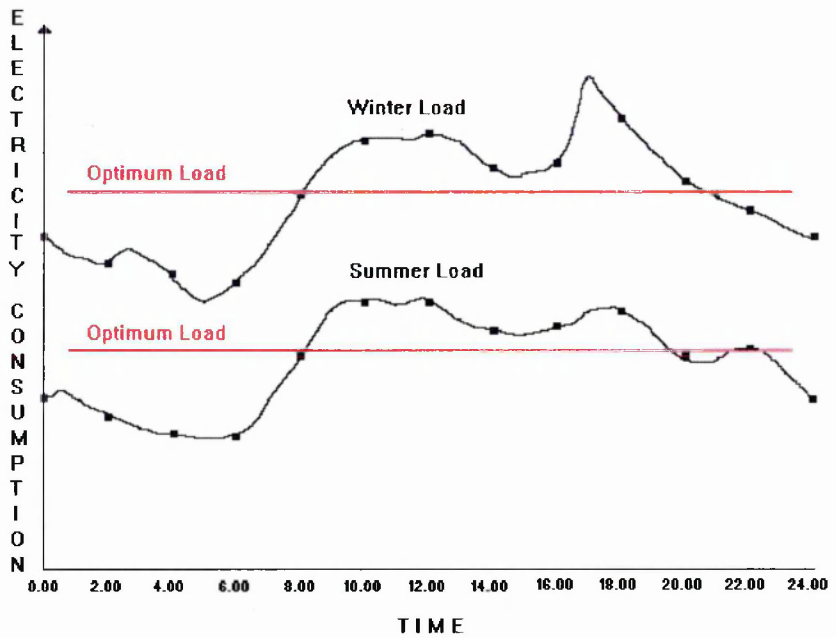

Fig 2.1 Typical Daily Load Profile .

Fig 2.1 illustrates how the consumption of electricity varies over a typical twenty four hour period ( by showing relative levels of consumption rather than absolute levels of consumption ) . The main characteristic of this load profile is the reduction in consumption during the period 22.00 hrs and 6.00 hrs and increase in consumption between 6.00 hrs and 20.00 hrs . The higher levels of consumption during the day are largely due to industrial and commercial consumers , whilst the increased consumption in the early hours of the evening may be attributed to domestic customers returning home from daily work and operating in - home appliances . One point of interest on the winter load curve is that at approximately 18.00 hrs . This may be explained by domestic customers returning from daily work and using heating in the colder months of the year .

### Power Station Scheduling

In the past a great deal of emphasis has been placed upon 'power station scheduling' , this involves the startup of generators to meet peaks in demand and the

shutdown of generators at times of low consumption in order to obtain a more economical generation of electricity [30],[31],[63] . It is achieved by providing power systems with hour by hour strategies for committing and withdrawing generating units in an economic and reliable manner . This type of scheduling was firstly implemented by withdrawing generators when their outputs fell to between 10% and 25% of maximum optimum output . Presently , power stations accomplish this by developing computerised schedulers which use algorithms based on load profiling data and demand forecasts in order to predict when startup / shutdown of generators will be required . Although simplistic in nature , this strategy suffers some limitations . For example , careful consideration must be made when shutting down coal fired stations , in such cases the minimum shutdown time may be several hours . In a situation such as this it may well be more economic to leave the plant 'on line' , running below its optimum output level .

The Electricity Supply Industry therefore adopted the philosophy of persuading the consumer to use electricity at specific times in order to create a 'flatter' load profile , by introducing demand side management strategies [96] . This was in contrast with the industries earlier policy of generating electricity at specific times to suit the customer .

Fig 2.1 shows the optimum ideal load which would be the most economical for a generator to supply . Although unrealistic , this would allow generating stations to be run at a constant , predictable speed thus reducing generation costs . Fig 2.1 is also an indication of the reasoning behind the variation in cost of electricity generation . The cost of generating electricity not only depends on the size of load to be supplied , but also on the type of generators which produce the electricity . Sharp peaks in demand are met by operating costly auxiliary generators ( gas and oil plants ) or by purchasing power from other utilities , thus increasing the cost of electricity .

This suggests that a fixed rate tariff does not reflect the varying cost of electricity generation .

### **2.1.1 Load Control**

Prior to privatisation , the area electricity boards devised a two rate tariff system to encourage customers to avoid loading the system during peak periods . This 'white meter' tariff was introduced in 1969 and combined the standard unit charge with the 'Economy 7' rate . This proved to be a success as it increased the consumption of off peak electricity .

Since privatisation more flexible tariff structures are being implemented by the area electricity boards . It is the intentions of the area boards to not only influence the consumer over when and what load to use , but also exhibit some form of 'remote control' over the customers load [32].

The action of a utility controlling a customers load is termed 'load control' and may be defined as adjusting the demand for electricity to match that of its supply . With reference to Fig 2.1 perhaps greater savings are to be made by the control of industrial loads as they are often bigger [33] , unfortunately the load control of industrial loads is harder to implement as interruptions in production are undesirable. With this in mind , the future of load control may well be directed towards the domestic consumer and in some cases the agricultural sector [34],[95] . As far as domestic load control is concerned there are several degrees to which it can be applied .

- i. Local Control: In this form of control the utility publishes multiple daily tariffs , thus leaving the decision with the consumer whether or not to use electricity at a certain time of day .
- ii. Direct Control: This allows the utility , with the permission of the customer , to install remote switches on certain appliances ( such as air conditioning and water heaters ) . The utility may then remotely operate these switches at peak demand times . This is commonly known as 'load shedding' [94] .

iii. Distributed Control: This type of load control is a combination of local control and direct control . The utility charges prices which follow the 'spot' price of electricity , hence the price the customer pays follows the trend of the actual cost of generating the power [91] .To accomplish this two factors are vital .

- ◆ The price data must be delivered to the customer quickly .
- ◆ The customer must interpret this data and apply it to appliance operation .

This type of load control introduces a whole new set of variables to the domestic customer . There will be customers who either do not understand or have not the time to exploit such a dynamic pricing strategy .

It is the intention that technologies such as home automation systems should provide a user friendly interface between the varying price of electricity and the appliances within the home which consume this electricity . The long term effects of such systems are not only financially beneficial to both customer and utility , but will also cause less damage to the environment due to reductions in electricity consumption.

### **2.1.2 The Future of Metering Services**

When the two tariff system of Economy 7 was introduced its success was reliant upon consumer products which could take advantage of its cheaper nightly rates ( for example electric storage heaters , water heaters etc. . ) . The introduction of a more complex tariff system highlights the need for a more 'intelligent' consumer product [100] . This has seen the emergence of home automation systems such as the 'ESPRIT' home system [35],[36], 'Smart Enabling System' [99] and the 'Consumer Electronic Bus' ( CEBus ) [37],[101] . It is the intention that these systems will provide a link between communications from the utility and intelligent consumer products , thus enabling the utilities to exercise more complex forms of load management .

As the right to 2nd tier supply for all consumers nears its introduction in April 1998 , the widespread use of utility / consumer communications is likely to begin with the implementation of remote metering systems for the 22 million domestic consumers . Such a system will not only have to perform the simple task of reading a customers electricity meter , but also that of downloading tariff data at selected time intervals . This is perhaps the most simplistic form of service which the utilities may consider . Anything less would not support the demands of the government electricity act of 1989 .

The introduction of a service even as basic as remote metering is a gross undertaking for the electrical supply industry . It has become quite clear that the remote meter reading of some 22 million consumers , together with the downloading of tariff data , cannot be accomplished by conventional means .

Before entering into the details of what a new approach to metering entails , it is relevant to discuss what remote metering and multiple tariff rates involve .

## **2.2 Metering Systems**

Firstly it is appropriate to discuss how multiple tariff rates are derived . This may be explained by examining the relationship between generation , supply , and cost .

It is the National Grid Company ( owned by the distribution companies ) that owns and operates the power transmission lines which facilitate the bulk transfer of electricity . The NGC is responsible for ensuring the generators meet demand at lowest cost .



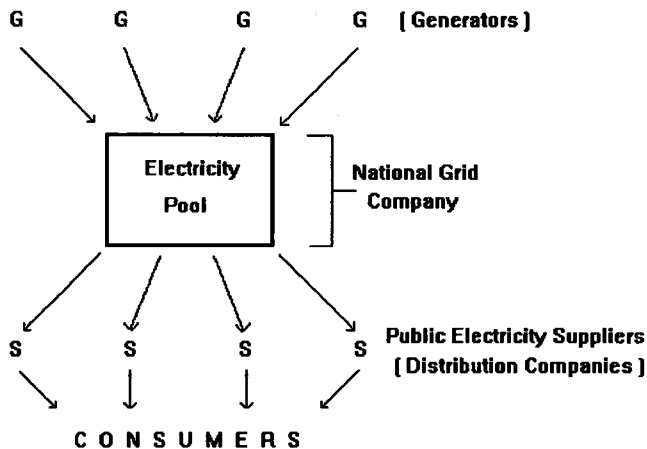

Fig 2.2: Relationship between Generation , Supply and Consumers .

Fig 2.2 shows the relationship between the generators , National Grid Company and distribution companies . It is the NGCs' responsibility to contract for capacity and supply from the generators , then negotiate contracts for selling electricity from its 'pool' to the distribution companies . The distribution companies in turn supply the consumers .

Transactions of electricity and payments are straight forward when the consumer purchases electricity from its local supplier , but in the case of second tier supply a more complex set of transactions takes place . For example if a customer wishes to purchase electricity from a second tier supplier , the customer will pay the second tier supplier for the metered consumption at the agreed rate . Then the second tier supplier will pay the customers local electricity supplier for use of its distribution network . Finally the second tier supplier will be charged via the 'pooling and settlement agreement' for the electricity it drew from the electricity pool .

### **2.2.1 Multiple Tariff Rates**

It is the intention that by April 1998 the cost of electricity for domestic consumers will follow the time varying nature of the 'pool' price . Prices in the pool will be set for each half hour of the day , reflecting the levels of demand at different times and the cost of supply from the various generators . The consumer will have a choice of tariff structures ranging from fixed rate tariffs to varying half hour charges which follow pool price . As for half hourly tariffs , the NGC will provide daily forecasts in advance , thus advising the customer of the cheapest time to use electricity .

The effect of electricity tariffs following the pool price is termed 'spot pricing' . For the domestic customer to implement this dynamic pricing strategy a means of providing the consumer with a daily price forecast is required . The approach to this problem has been to adopt 'remote metering' . This not only facilitates the remote reading of a consumers electricity meter , but also the downloading of tariff data .

As the widespread introduction of spot pricing to all domestic consumers has not yet taken place , one can only speculate how this problem will be addressed . The following approach may be taken .

- ◆ The electricity utility will download half hourly price data to all its customers a day in advance . This information would be in the form of a 'broadcast' as it is common to all consumers . In this case the utility must decide which is the most economic means of conveying this information .
- ◆ Tariff data will be stored in an 'intelligent' electricity meter which not only displays this information to the consumer , but also records the quantity of electricity used.
- ◆ The utility must then recover data from each customer regarding the quantity of electricity consumed . At this point the utility must decide how often it is necessary to 'read' the consumers meter . This decision may well be based on how many meters it is possible to read in a set time , bearing in mind the number of consumers and the maximum

data rates possible over the chosen communications media . Presently the general consensus is the a mean time between meter reads of one to four weeks will suffice the needs of both utility and consumer .

The introduction of spot pricing and remote meter reading has highlighted the need for an 'intelligent' domestic electricity meter . Currently , several manufacturers have taken on the challenge of developing and marketing such products . The next section of this chapter will introduce these new technologies .

### **2.2.2 The 'Intelligent' Meter**

For over one hundred years the method of measuring the quantity of electricity used by a consumer has remained relatively unchanged . Consequently the electromechanical watt hour meter , devised by Ferraris , has become a proven technology which has been adopted by electricity supply industries world wide . Its low unit cost , due to the high volumes of production , has maintained its widespread use until recent years . With recent changes in pricing and supply strategies , driven by government acts , the need for a new method of metering the consumers electricity has arisen .

This new approach to measuring the consumption of electricity will now be discussed by reviewing products available to date , together with the services which they provide .

One of the most simplistic approaches taken is that of modifying the electromechanical meter which is already installed in the consumers premises [38] . This involves fitting a small circuit board inside the customers electricity meter . The circuit board optically reads disc revolutions and derives kWh , peak and power outage data . Using a PLC transmitter the recorded data is transmitted along the power line for interpretation by the utility . This particular device may also be used for 'reading' the pulses from electronic type meters which may include gas and water meters .

The simple nature of this approach results in an inexpensive , easy to install system. Unfortunately these factors limit the complexity of services which may be provided by this particular type of system .

An alternative approach is to install a new Ferraris type meter equipped with an 'added' on electronic unit which facilitates data processing and two way PLC communications [39] . The Ferraris meters are provided with a metering pulse generator device . This is basically an optic sensor attached to the disc of the meter which provides a train of pulses related to the rate of rotation of the disc .

The electronic unit allows multi rate tariffs to be displayed and supply voltage conditions to be monitored . The unit is also programmable in order that a program of load control may be established , and consumption information is provided for the utility which may be used for planning and load profiling .

With future home automation systems in mind the electronic unit may be used to convey information using a PLC via the consumers in house wiring . This would permit various parameters of the customers consumption to be monitored such as tariff and bill information , consumed power , load management status , and possibly consumption data of other amenities such as water and gas . The use of interactive teletext monitors would enable the consumer to display this information and interrogate and program the electronic unit for the load control of other products connected to the mains circuit .

An example of a modular intelligent metering system is a product designed and manufactured by Thorn EMI [40] . This system provides an intelligent metering service together with two way PLC communications to the consumers premises . The system sited on the consumers premises consists of an Energy management home unit , an optional customer display unit and a contactor unit which is also optional .

- ◆ **Energy management home unit:** This is microprocessor based and accepts pulse inputs from suitable electricity , gas and water meters . These pulses may be derived from a conventional Ferraris meter fitted with a suitable pulse interface . The unit contains tariff rate registers to accumulate consumption data for transfer to the appropriate utility . Consumption information is held in memory for interrogation by the utility central controller . An on board transmitter / receiver is used for PLC signalling along the low voltage feeders to the central controller . An LCD display is also provided which shows consumption information for different tariff rates . The presence of an 'on board' memory provides a facility for the bulk transfer of consumption data to the utility . This means that the meter may be read on a weekly or monthly basis rather than daily , thus reducing the quantity of transmitted data .
- ◆ **Customer display unit:** This module is used to display data such as consumption , costs , tariff rates , bill predictions , bill to date and status of appliance programmes together with their operating times . Load control commands from the utility may also be displayed by this module , the consumer than has the ability to either follow the utilities load control schedule or operate loads manually via this unit .
- ◆ **Contacting unit:** A contacting unit , containing relays , is available for controlling loads with the energy management home units' programme , or manually with the customer display unit .

The modular nature of this system enables the customer to make the decision on the degree of service to opt for . Such an approach to a modular system is promoted by the Beama Metering Association ( BMA ) . This approach is further backed by Schlumberger Industries and Ampy Automation , who are currently promoting their own modular systems [41] .

Amongst the advantages of adopting intelligent meter technology is the ability to introduce more flexible and convenient methods of bill payment . Pre payment systems will be available when the customer purchases a 'smart' card from the utility which plugs into the intelligent meter and enables the supply . When the card expires the customer

simply purchases another . This system would replace the inconvenience of outdated coin meters and also combat fraud [42] .

For customers with banking facilities a direct debit system may operate . In this case the customers meter could be read daily and the utility would debit the customers account by the appropriate amount . This would eliminate the need for the utility to invoice the customer , therefore reducing administrative overheads .

Now that an insight into the services which intelligent forms of metering will bring has been provided , it is appropriate to investigate the data rates involved in such systems. The data rates are not only related to the degree of service which is provided , but also to the communications architecture of the particular system .

## **2.3 Network Architecture**

In order to examine the communications architecture of the system , the layout of the distribution network must firstly be considered . For these reasons a study of a section of Manwebs' mid Mersey 11kV network has been made in order to establish typical values of consumers per distribution substation and distribution substations per primary . This particular study is representative of a semi rural area and will provide an insight into the type of consumers present on this type of network .

### **2.3.1 11kV Network**

Fig 2.3 shows a portion of Manwebs' mid Mersey 11kV network . This particular section illustrates the networks architecture surrounding three primary substations , each of 7.5 MVA rating . Although interconnected in nature this particular part of the network may be sectionalised from the rest and is typical of a 'primary network system' shown in

Fig 1:4 , section 1.2.1 , chapter 1 . In examining this part of the network it is possible to obtain an approximate ratio of distribution substations per primary substation .

Referring to Fig 2.3 , the three primary substations are interconnected and jointly feed 24 distribution substations which serve residential and light industrial units , together with a semi rural residential network containing approximately 100 distribution substations .

Looking more closely at the 11kV feeders numbered 1 and 2 , as shown in Fig 2.4 , reveals that this particular area contains not only domestic consumers , but light industrial units which are also linked to the 11kV supply . Also several more 'heavier' industrial customers are supplied including 'British Gypsum' , 'Bass' , 'American Can' and 'Guinness' . It is this industrial presence that keeps the mean ratio of distribution substations per primary substation relatively low . However , some of the 11kV feeders do supply purely residential semi rural areas , namely feeders 3 and 4 in fig 2.3 . If this part of the networks section was considered in isolation , the number of distribution substations per primary would of course be much higher , as in the case of all semi rural residential areas . Because of this sections interconnected nature it must be looked at as a whole . Therefore the approximate number of distribution substations per primary is  $\frac{148}{3} \approx 50$  .

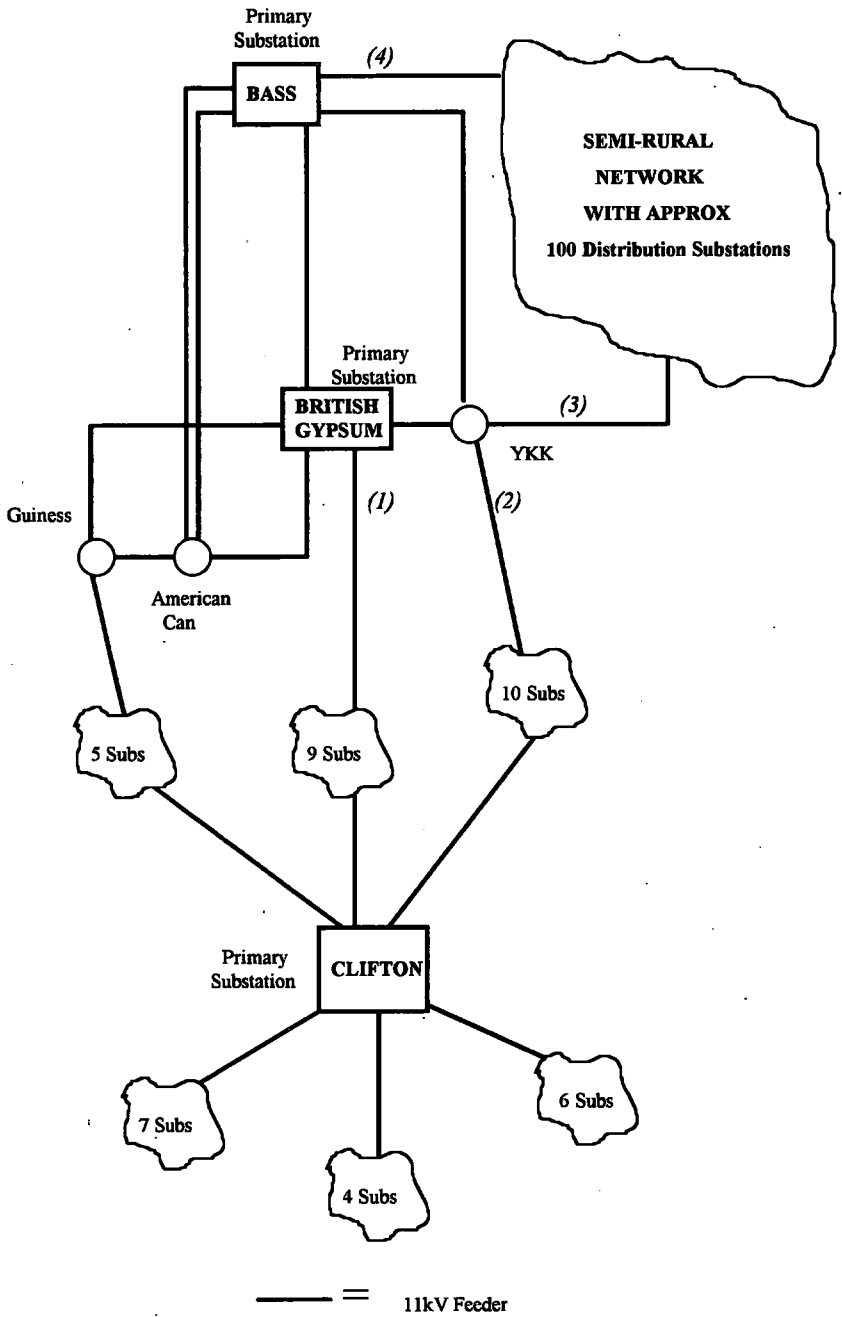

Fig 2.3: Primary ( 11kV ) Distribution Architecture .



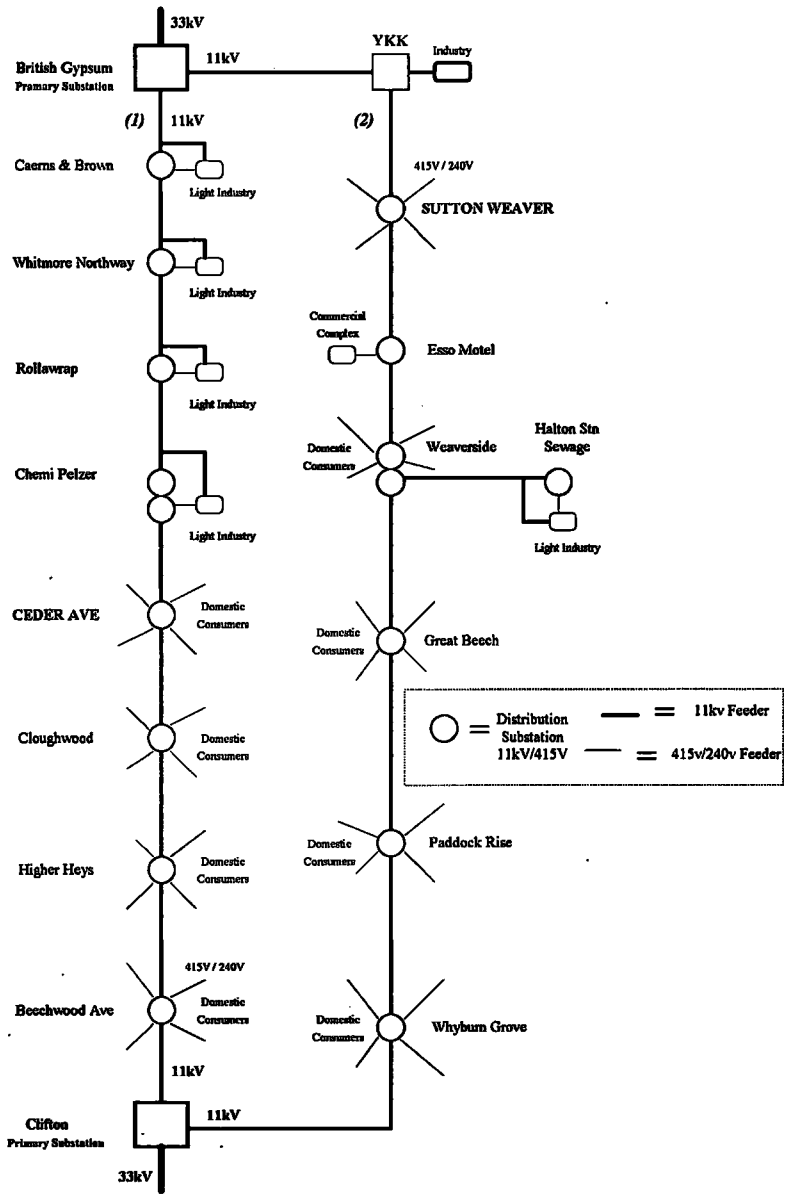

Fig 2.4: Primary / Secondary Distribution Network .

### 2.3.2 LV Network

The 11kV ( MV ) network supplies distribution transformers ranging from 15 kVA pole mounted types , which supply more isolated loads such as farms , to 500kVA substation types which supply 'clusters' of residential consumers . One distribution substation of particular interest is that of the 500kVA Ceder Ave ( shown in fig 2.4 ) . This particular substation provides 415V / 240V supply for approximately 120 domestic consumers .

For comparison a study has been made of Eastern electricity's substations and consumers . This study provides an overall picture of Eastern electricity , as the following figures are representative of the entire region .

- ◆ Total number of primary substations ( 33kV / 11kV ) = 445 .
- ◆ Total number of Distribution substations ( 11kV / 415V-240V ) = 56,000 .
  
- ◆ Overhead distribution:  
33,000 substations , :      Average number of consumers per substation =  
400,000 consumers , :       $\frac{400,000}{33,000} = 12 .$
  
- ◆ Underground distribution:  
23,000 substations , :      Average number of consumers per substation =  
400,000 consumers , :       $\frac{2,600,000}{23,000} = 113 .$
  
- ◆ Average number of distribution substations per primary substation =  $\frac{56,000}{445} = 126$

One of the main similarities between these figures and the ones obtained from the Manweb mid Mersey district area , is the average number of consumers per distribution substation on the underground network .

In the case of the overhead distribution network the average number of consumers per substation is 12 . This is primarily due to the rural nature of this part of the network . An important statistic which differs quite considerably is that of distribution transformers per primary substation . For the Manweb network a ratio of 50 to 1 compares with 126 to 1 of Eastern electricity . This is largely due to the more industrial nature of the particular section of the Manweb network studied , where the number of distribution transformers is fewer , but larger in size .

As in the case of the Manweb network the figures are averages and throughout the country extremes will be encountered .

These figures may be used as a basis for estimating the data rates involved in implementing a remote metering system . Of course these figures are only approximate and in the case of the Manweb network only apply to the particular type of residential LV network studied . It must be noted that in sparsely populated rural areas and densely populated city areas these figures will vary quite considerably . It is therefore appropriate to use figures based on rural , semi rural and urban areas in order to fully cover the extremes involved in remote metering data rates .

## **2.4 PLC Protocol**

Having derived approximate figures which reflect the number of primary substations , distribution substations and consumers on typical rural , semi rural and urban networks , a study of data rates is possible . In order to obtain the quantity of data required for meter read , tariff download and load control operations , the PLC protocol must firstly be examined .

### 2.4.1 Consumption Data

The general consensus of the electricity supply industry and 'intelligent' meter manufacturers appears to be that the domestic consumers meter will be read on a weekly to monthly basis for consumption data . For the purpose of this analysis a mean time between meter reads of two weeks is chosen as a compromise between these two extremes . At present the depth of this analysis will be limited to a communication system operating solely on the LV mains distribution network . Its topology is illustrated in fig 2.6.

A meter reading operation will comprise of an outgoing message ( from a central controller to a consumers meter ) , together with an incoming message ( from the consumers meter to the central controller ) . The length of such a message is dependant upon the particular mains signalling protocol used . With reference to Thorn EMI's mainsborne protocol [43] a typical 'meter read' message is as follows .

| <b>' METER READ ' MESSAGE</b> |               |                        |                            |                |                       |               |                |               |
|-------------------------------|---------------|------------------------|----------------------------|----------------|-----------------------|---------------|----------------|---------------|
| Opening Flag                  | Control Field | Extended Control Field | Addressing:                | Data Field:    |                       |               | CRC            | Closing Flag  |
|                               |               |                        | 0 to 15 Repeaters          | Target address | Data transfer Command | Check Sum     |                |               |
| <i>1 byte</i>                 | <i>1 byte</i> | <i>12 bits</i>         | <i>12 bits to 204 bits</i> | <i>2 bytes</i> | <i>3 bytes + data</i> | <i>1 byte</i> | <i>2 bytes</i> | <i>1 byte</i> |

Fig 2.5 : Meter read message protocol .

In the above message no data will be present in the outgoing transmission .

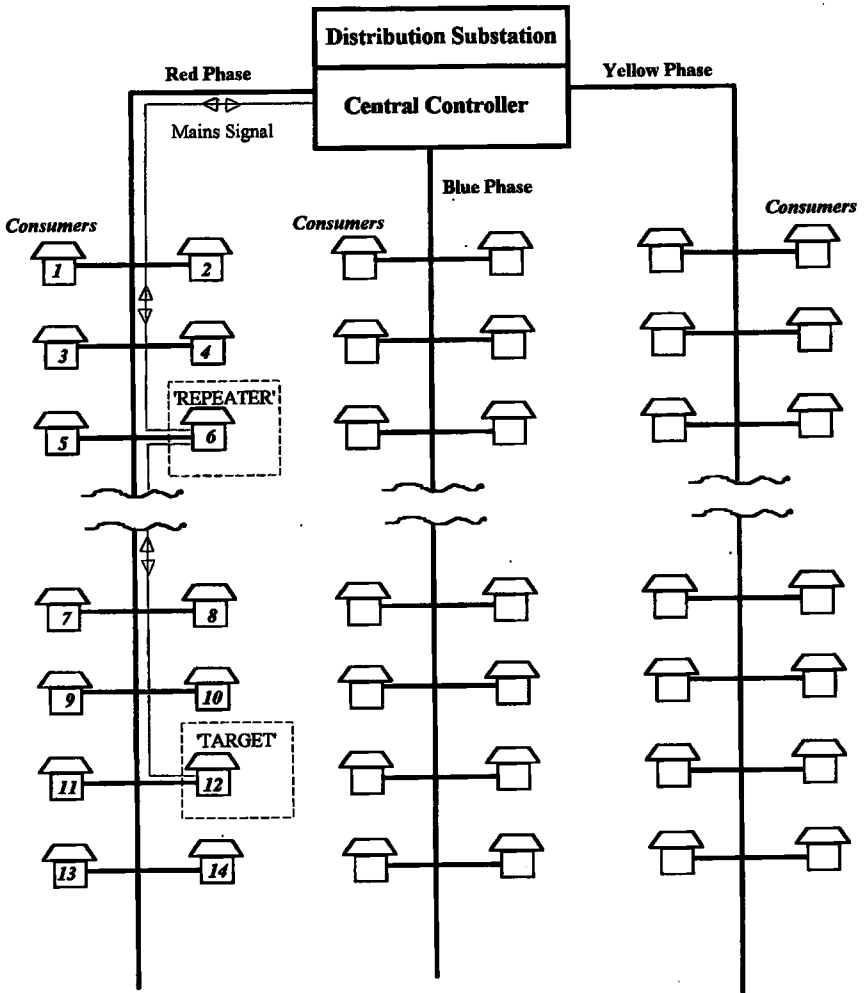

Fig 2.6: LV Meter read operation .

This particular protocol incorporates a facility for using the consumers meter as a 'repeater'. Remote metering systems such as the ARGUS project [44] have also adopted the 'repeater' concept in order to increase transmission range. The function of a repeater is to relay the message intended for the 'target' meter in times of poor signal propagation. Fig 2.6 illustrates the use of a repeater at consumer number 6 where the message is relayed to the target consumer ( consumer number 12 ).

In the meter read message the length of the addressing field is dependant upon the use of repeaters . At times of poor signal propagation and at a greater distance from the central controller , more repeaters will be necessary than at times of good propagation over a short distance . This particular system allows for a maximum of 15 repeaters in the communications path . Of course this will only occur in extreme conditions . Fig 2.7 reflects how the number of repeaters will vary with increasing transmission distance and a degradation in signal propagation . On average it is expected , using this particular system and protocol , that two repeaters per communications path will be used . Fig 2.8 illustrates the distribution of the number of repeaters used in a message transmission . From this distribution it is clear that an average of two repeaters may be considered typical in order to provide a basis for estimating expected message lengths . The address of each of these repeaters , together with the current and next in line repeater in the communications path is contained in the addressing field . Therefore , assuming an average of two repeaters the total length of an outgoing message will be 20 bytes . This figure is of course an average and could vary between 14 bytes ( no repeaters ) and 40 bytes ( 15 repeaters ) .

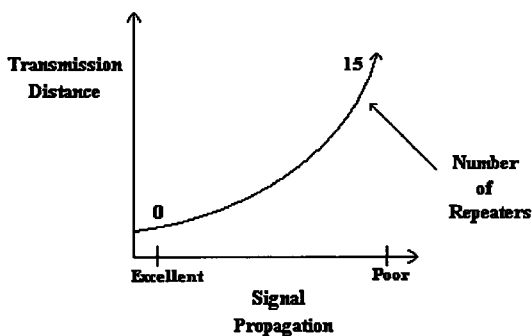

Fig 2.7: Use of repeaters .

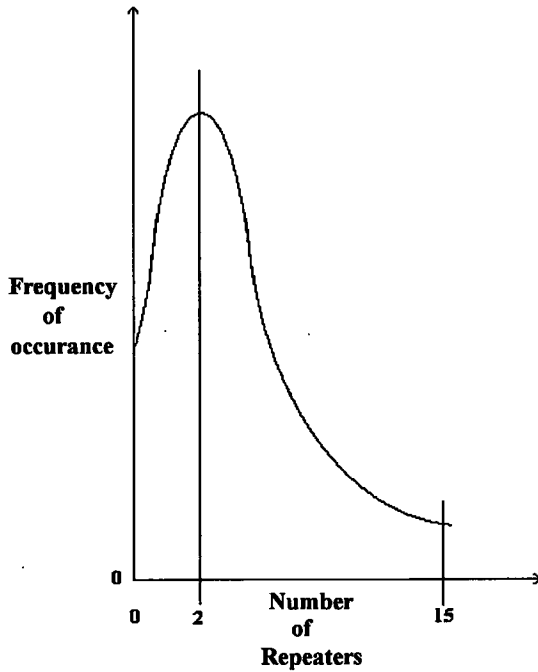

Fig 2.8: Repeater distribution .

In the case of an incoming message from the consumers meter to the central controller the message will contain consumption data from the consumers meter . The length of this data field will vary from 1 byte to 16 bytes . It is expected that the length of this data will be a function of how often the consumers meter is read . For the purpose of this study an average data field length of 8 bytes will be used . These 8 bytes of data will be added to the message on its incoming route . Hence the total length of incoming message will be 28 bytes ( using 2 repeaters ) .

Using these figures it is possible to state the approximate quantity of data required to perform a meter read operation for one consumer . This will be a total of **48 bytes** using an average of two repeaters and a data field of 8 bytes .

## 2.4.2 Tariff Data Download

Although it is intended that by April 1998 all domestic consumers will be charged at tariff rates which vary on a half hourly basis , it is the opinion of the utilities that tariffs will fluctuate on a more infrequent basis . As multiple tariff rates have not yet been widely introduced in the domestic consumers market , a certain degree of speculation must enter into the analysis of the data rates involved in the provision of such a service . It is expected that the vast majority of domestic consumers would not respond , by modifying their consumption habits , to an electricity tariff which changes every half hour . For this reason a tariff which changes less often is more likely to be adopted .

A compromise between the basic two tariff 'Economy 7' and half hourly tariffs must be reached . For the purpose of this analysis a tariff which changes , on average , every two hours is hypothesised . Using this assumption , 12 electricity tariffs must be downloaded to the consumers meter on a daily basis , a day in advance of their effect .

The download of tariff data will be accomplished by a 'broadcast' type message , as the data is common to all consumers in a particular area . The protocol for a broadcast message is shown in fig 2.9 .

| BROADCAST MESSAGE |               |                        |                          |               |                |                       |               |                |               |
|-------------------|---------------|------------------------|--------------------------|---------------|----------------|-----------------------|---------------|----------------|---------------|
| Opening Flag      | Control Field | Extended Control Field | Broadcast Address Field: | PAD           | Data Field:    |                       |               | CRC            | Closing Flag  |
|                   |               |                        |                          |               | Target address | Data transfer Command | Check Sum     |                |               |
| <i>1 byte</i>     | <i>1 byte</i> | <i>12 bits</i>         | <i>4 bytes</i>           | <i>4 bits</i> | <i>2 bytes</i> | <i>3 bytes + data</i> | <i>1 byte</i> | <i>2 bytes</i> | <i>1 byte</i> |

Fig 2.9: Broadcast message protocol .

Due to the nature of this message it will only be a one way transmission . Unlike the meter read message it is not necessary to incorporate the address of every meter used as a repeater . The common nature of the message means that each meter simply relays the message to the next meter in line as shown in fig 2.10 . This limits the broadcast



address field to 4 bytes . Hence the total message length is a function of 17 bytes plus the data field , where the data field is related to the tariff rate information . If a data field of 12 bytes is used for the download of 12 tariff rates per day , then the total length of the broadcast message will be 29 bytes .

The broadcast of tariff data will take place on a daily basis in an outgoing direction from the central controller to the consumers meter .

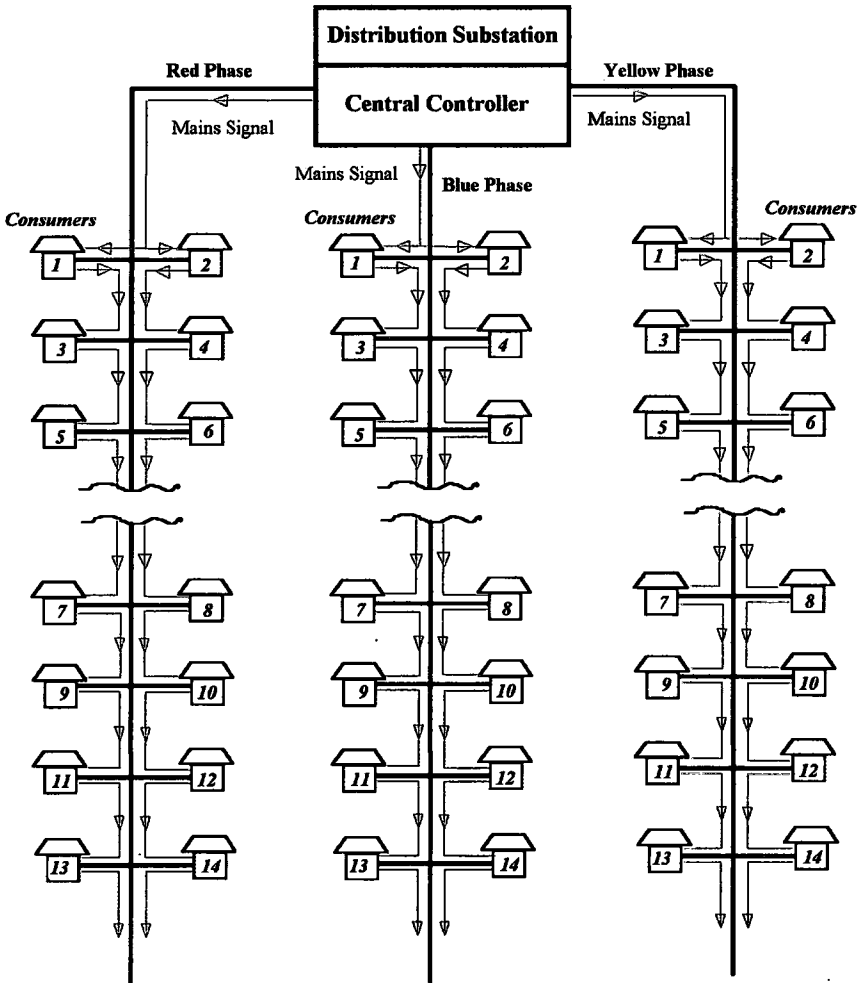

Fig 2.10: LV broadcast operation .

### **2.4.3 Load Control Messages :**

As in the case of downloading tariff data , the downloading of load control data will be in the form of a broadcast type message common to all consumers as in fig 2.10 . The addressing fields of the message will be structured in the same way as tariff messages and relayed from consumer to consumer as shown in fig 2.10 . This implies a total message length of 17 bytes , plus the data field . Here the data represents load control information which provides the utility with a means of switching the consumers loads on or off via relay switching units . The quantity of data in the data field may range from 1 to 16 bytes , depending upon the amount of load control information transmitted . As this information may be used to control several loads on the consumers premises , several times a day , it is highly probable that the data field will convey its maximum of 16 bytes . Therefore the total message length may be estimated at **33 bytes** and will be transmitted on a daily basis in advance .

## **2.5 LV Data Rates**

Using the figures obtained from sections 2.3 on distribution network architecture and section 2.4 on the PLC protocol , it is possible to derive the data rates involved in providing the services discussed so far on a typical LV distribution network . Data rates may be calculated for the three extremes encountered in network architecture , namely , rural , semi rural and urban . The aim of this study is to provide an average daily data rate for varying degrees of service .

### **2.5.1 Rural Network**

From the study of section 2.3 the average number of consumers per distribution substation , in a rural area , may be approximated at 10 . These 10 consumers will then be distributed between the three phases of the distribution transformer . Hence an average of

three consumers per phase will be used . It must be noted that in some cases a consumer will use all three phases of the supply . This situation is typical for consumers such as farms . In cases such as these it is usual that a ratio of one consumer per transformer is encountered .

The quantity of data required to provide a remote meter read , tariff download and load control service may now be calculated . As it is expected that a meter read operation will be performed every two weeks , the total quantity of data for a two week period will be calculated before the average daily quantity is determined .

◆ **Meter Read Data** : For this operation the quantity of data per phase , every two weeks will be ;

$$\begin{aligned} \text{Number of consumers} * \text{Meter read message} &= \\ 3 * 48 \text{ bytes} &= 144 \text{ bytes per two week period} \end{aligned}$$

The total data which the central controller must process in a two week period will be ;

$$\begin{aligned} \text{Number of consumers} * \text{Meter read message} &= \\ 10 * 48 \text{ bytes} &= 480 \text{ bytes per two week period} \end{aligned}$$

◆ **Tariff Download Data** : This operation is performed on a daily basis and is common to all three phases of the supply . The quantity of data over a two week period will be ;

$$\begin{aligned} \text{Number of days} * \text{Tariff download message} &= \\ 14 * 29 \text{ bytes} &= 406 \text{ bytes per two week period} \end{aligned}$$

◆ **Load Control Data** : This message transmission will also occur on a daily basis and is common to all three phases of supply . Over a two week period the quantity of data will be ;

Number of days \* Load control message =

$$14 * 33 \text{ bytes} = 462 \text{ bytes per two week period}$$

◆ Total Data : For the provision of these services over a two week period the following quantity of data will be required ;

$$\text{Per phase} = 144 + 406 + 462 = 1012 \text{ bytes per two week period}$$

$$\text{Per central controller} = 480 + 406 + 462 = 1348 \text{ bytes per two week period}$$

These figures are only representative of the electricity utility . It is expected that an intelligent meter will provide the means to store data regarding the consumption of water and gas . With this in mind it is likely that the water and gas utilities would add to the quantity of meter read data which is transmitted over the network . The total data required over a two week period will now be ;

$$\text{Per phase} = ( 144 )3 + 406 + 462 = 1300 \text{ bytes per two week period}$$

$$\text{Per central controller} = ( 480 )3 + 406 + 462 = 2308 \text{ bytes per two week period}$$

This quantity of data represents the net data rate and does not include re transmissions due to erroneous and failed messages . To obtain the raw data rate a 'loading factor' may be included . A conservative estimate of 20 % may be added to the net data rate to provide a loading factor . The data quantities will now be increased .

$$\text{Per phase} = 1300 + ( 1300 )0.2 = 1560 \text{ bytes per two week period}$$

$$\text{Per central controller} = 2308 + ( 2308 )0.2 = 2770 \text{ bytes per two week period}$$

The data quantity on a daily basis may now be calculated ;

$$\text{Per phase} = \frac{1560}{14} = 111 \text{ bytes per day}$$

$$\text{Per central controller} = \frac{2770}{14} = 198 \text{ bytes per day}$$

Due to the more heavily loaded nature of the distribution network during the day , it is expected that transmission of data will occur between midnight and 05:00 hrs . The data rate per hour will therefore be ;

$$\frac{111}{5} = 22.2 \text{ bytes per phase per hour}$$

$$\frac{198}{5} = 39.6 \text{ bytes per central controller per hour}$$

### **2.5.3 Semi Rural Network**

Referring to the study of section 2.3 , the ratio of consumers per distribution substation was 120 to 1 . These figures will increase the rural data rates by a factor of 12 . Hence the data rate per hour for a typical semi rural network will be ;

$$22.2 * 12 = 266.4 \text{ bytes per phase per hour}$$

$$39.6 * 12 = 475.2 \text{ bytes per central controller per hour}$$

### **2.5.3 Urban Network**

For this type of network the typical number of consumers per substation is expected to be around 300 [45] . This figure will increase the quantity of data by a factor of 30 from that of the rural network . Therefore the following data rates , in bytes per hour , are expected .

$$22.2 * 30 = 666 \text{ bytes per phase per hour}$$

$$39.6 * 30 = 1188 \text{ bytes per central controller per hour}$$

A summary may now be provided regarding the data rates required on rural , semi rural and urban networks . The data rates are the minimum deemed necessary to support remote meter reading , download of tariff data and load control services .

| <i>Data Rate ,<br/>bytes per hour</i> | <i>Rural<br/>Network</i> | <i>Semi Rural<br/>Network</i> | <i>Urban<br/>Network</i> |
|---------------------------------------|--------------------------|-------------------------------|--------------------------|
| <i>Per Phase</i>                      | <b>22.2</b>              | <b>266.4</b>                  | <b>666</b>               |
| <i>Per central cont.</i>              | <b>39.6</b>              | <b>475.2</b>                  | <b>1188</b>              |

Table 2.1: LV Data rate summary .

These figures may be represented in graphical form as in Fig 2.11 . Using this representation it remains possible to extrapolate these data rate figures in order to obtain approximate data rates for intermediate numbers of consumers .

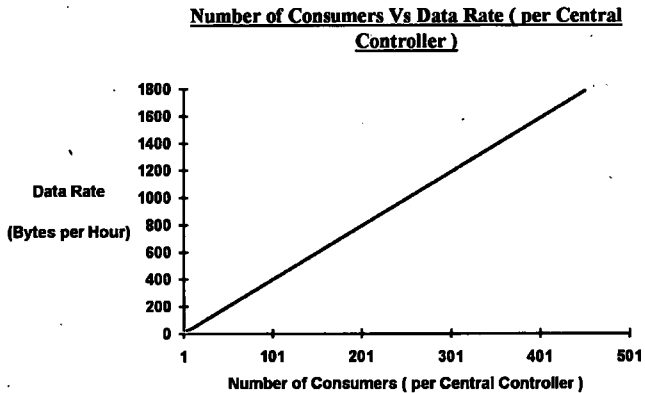

Fig 2.11: Variation in data rate related to number of consumers .

## **2.6 MV Data Rates**

Now that the data rates associated with signalling on the LV ( 240V / 415V ) distribution network have been analysed , the MV ( 11KV ) network may now be considered . This type of system topology involves the removal of the central controller

from the distribution substation , and either bypassing or signalling through the distribution transformer as in the cases of Fig 1.12 and Fig 1.13 of section 1.5 , chapter 1 respectively .

### 2.6.1 Communication Architecture

The following communication architecture may now be realised .

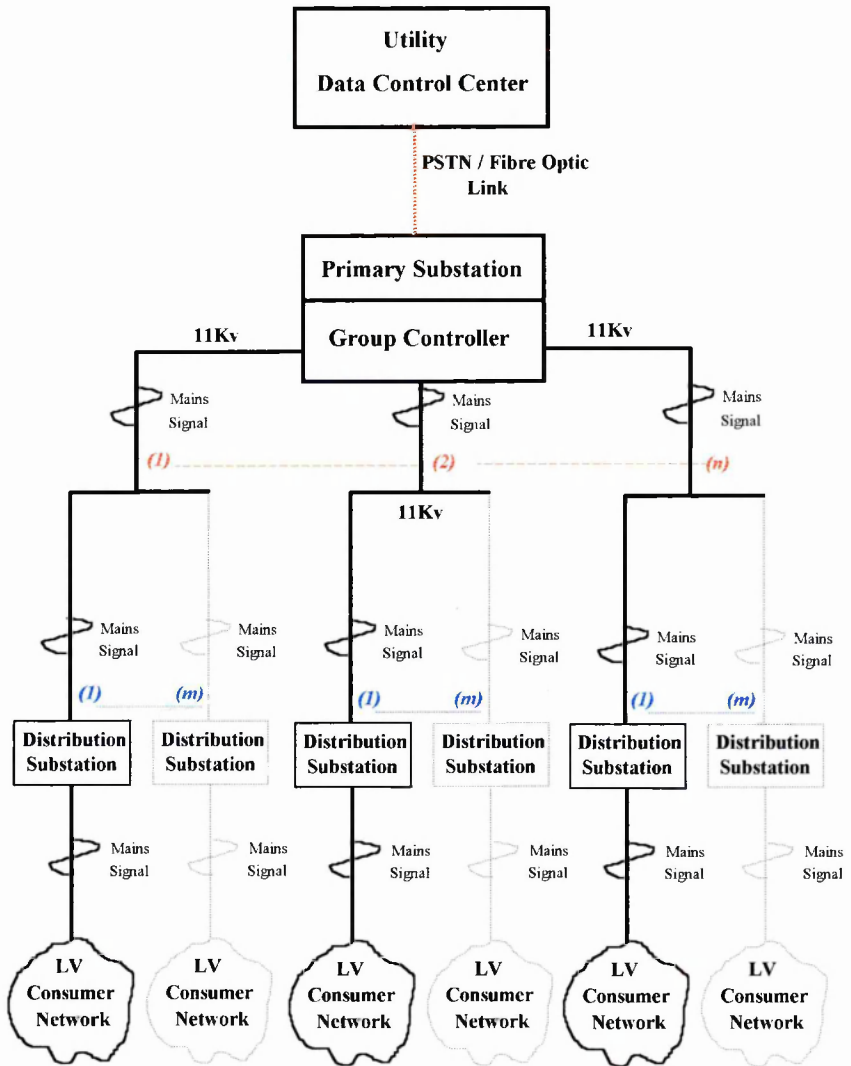

Fig 2.12: MV / LV Communications Architecture .

In Fig 2.12 the 'group' controller provides the intelligent interface between the utilities data control centre and the mains signalling network . With the central controllers removed from the distribution substations , the group controller is responsible for the remote metering operations . The primary substation will supply up to ' $n$ ' 11kV feeders ( as in Fig 2.3 ) , ' $n$ ' depending upon the type of distribution network , be it rural , urban etc . These 11kV feeders will in turn supply up to ' $m$ ' distribution substations and their local consumer networks .

With the analysis of distribution network maps , as in section 2.3 , it is possible to arrive at approximate figures which reflect the number of MV feeders per primary substation , together with the number of distribution substations , and of course LV consumers per primary . The study of such networks has arrived at the following important conclusions .

- ♦ The number of LV consumers per primary substation remains relatively constant in semi rural and urban areas due to the constant MVA rating of the primary transformers.
  
- ♦ The isolated nature of rural networks will cause a large increase in the number of distribution transformers per primary substation . This is largely due to the fact that individual consumers and small groups of consumers will be supplied by a single transformer in order to eliminate the necessity of unfeasibly long LV feeders . Sparsely populated areas such as these will also have fewer consumers per primary . A conservative estimate of the number of distribution transformers per primary is between two to four hundred . Yet again a compromise between these two extremes of 300 distribution transformers per primary will be used for the purpose of this analysis .
  
- ♦ The quantity of data which the group controller must process will be a function of the total number of consumers on the distribution network .



Approximate figures for consumers and substations for rural , semi rural and urban networks may now be summarised .

|  | <i>Rural<br/>Network</i> | <i>Semi Rural<br/>Network</i> | <i>Urban<br/>Network</i> |
|--|--------------------------|-------------------------------|--------------------------|
| <i>Consumers per<br/>Substation</i>                  | <b>12</b>                | <b>120</b>                    | <b>300</b>               |
| <i>Substations per<br/>Primary Sub.</i>              | <b>300</b>               | <b>50</b>                     | <b>20</b>                |
| <i>Total # of<br/>Consumers per<br/>Primary Sub.</i> | <b>3600</b>              | <b>6000</b>                   | <b>6000</b>              |

Table 2.2: Network Statistics .

It must be re emphasised that these figures are only approximate in nature and will only provide an estimate for the data rate requirements of a PLC system . The data rates for the three types of network may now be calculated using figures obtained from table 2.1 and table 2.2 .

The following calculations , in sections 2.6.2 to 2.6.4 , make the assumption that some form of data division at the group controller level , for example injecting into 'built in' fibre optic links .

Section 2.6.5 discusses the realities of a 'pure' PLC system .

## 2.6.2 Rural Network

i) Group Controller data rate;

$$\begin{aligned}\text{Data Rate ( bytes per hour )} &= \left( \begin{array}{c} \text{Total Number of distribution} \\ \text{transformers} \end{array} \right) * \left( \begin{array}{c} \text{Data rate per distribution} \\ \text{transformer} \end{array} \right) \\ &= [n][m] * 39.6 \\ &= 300 * 39.6 = \mathbf{11880} \text{ bytes per hour}\end{aligned}$$

ii) Through transformer signalling rate;

$$\begin{aligned}\text{Data Rate ( bytes per hour )} &\equiv \frac{\text{Group Controller data rate}}{\text{Total number of distribution transformers}} \\ &= \frac{11880}{300} = \mathbf{39.6} \text{ bytes per hour}\end{aligned}$$

## 2.6.3 Semi Rural Network

i) Group Controller data rate;

$$\begin{aligned}\text{Data Rate ( bytes per hour )} &= \left( \begin{array}{c} \text{Total Number of distribution} \\ \text{substations} \end{array} \right) * \left( \begin{array}{c} \text{Data rate per distribution} \\ \text{substation} \end{array} \right) \\ &= [m][n] * 475.2 \\ &= 50 * 475.2 = \mathbf{23760} \text{ bytes per hour}\end{aligned}$$

ii) Through transformer signalling rate;

$$\begin{aligned}\text{Data Rate ( bytes per hour )} &= \frac{\text{Group Controller data rate}}{\text{Total number of distribution substations}} \\ &= \frac{23760}{50} = 475.2 \text{ bytes per hour}\end{aligned}$$

#### 2.6.4 Urban Network

i) Group Controller data rate;

$$\begin{aligned}\text{Data Rate ( bytes per hour )} &= \left( \begin{array}{c} \text{Total Number of distribution} \\ \text{substations} \end{array} \right) * \left( \begin{array}{c} \text{Data rate per distribution} \\ \text{substation} \end{array} \right) \\ &= [m][n] * 1188 \\ &= 20 * 1188 = \mathbf{23,760} \text{ bytes per hour}\end{aligned}$$

ii) Through transformer signalling rate;

$$\begin{aligned}\text{Data Rate ( bytes per hour )} &= \frac{\text{Group Controller data rate}}{\text{Total number of distribution substations}} \\ &= \frac{23,760}{20} = \mathbf{1188} \text{ bytes per hour}\end{aligned}$$

A summary may now be provided for the three types of network , regarding the data rates required for the group controller and through transformer signalling .

| <i>Data rate<br/>bytes per hour</i>                | <i>Rural<br/>Network</i> | <i>Semi Rural<br/>Network</i> | <i>Urban<br/>Network</i> |
|--|--------------------------|-------------------------------|--------------------------|
| <i>Per Group<br/>Controller</i>                    | <b>11,880</b>            | <b>23,760</b>                 | <b>23,760</b>            |
| <i>Through<br/>transformer<br/>signalling rate</i> | <b>39.6</b>              | <b>475.2</b>                  | <b>1188</b>              |

Table 2.3: MV data rate summary

The data rates outlined in table 2.3 are of a communications system which necessitates a form of intelligent interface sited on the distribution transformers MV side . This would provide a data rate conversion from the slower LV signalling rates , of table 2.1 , and the faster group controller signalling rates of table 2.3 .

### **2.6.5 The Realities of a 'Pure' PLC System**

However , the inclusion of such an intelligent interface remains somewhat difficult to justify , given the impracticalities which would be encountered when interconnecting such a device on the MV feeder side of the distribution substation . Therefore the exclusion of such a device would necessitate both the MV and LV network to operate at the same signalling rate . With this approach it would be the group controllers signalling rate which governs the MV and LV networks signalling rates .

This reasoning implies the following through transformer signalling rates for a direct consumer to group controller system .

| <i>Data rate<br/>bytes per hour</i>                | <i>Rural<br/>Network</i> | <i>Semi Rural<br/>Network</i> | <i>Urban<br/>Network</i> |
|--|--------------------------|-------------------------------|--------------------------|
| <i>Through<br/>Transformer<br/>Signalling rate</i> | <b>11,880</b>            | <b>23,760</b>                 | <b>23,760</b>            |

Table 2.4: Through Transformer Data Rates .

The data rates summarised in table 2.4 , which translate to the tens of bits per second range , reflect the lower signalling rates which will be encountered on rural networks . With the through transformer signalling rate being directly proportional to the number of consumers per primary distribution network , densely populated urban areas will inherently possess greater through transformer data rates . This implies that a PLC communications system which employs a through transformer signalling strategy would be more suited to a rural network .

In addition the complications and economics involved in installing a PSTN of fibre optic link to every distribution transformer in a rural network ( as in fig 1.10 and 1.11 , section 1.5 , chapter 1 ) further emphasise the preference of adopting a through transformer signalling technique .

This by no means suggests that through transformer signalling would be inappropriate on a densely populated urban network . The factors which influence the communication architecture will strongly be related to the cost per consumer for the provision of the metering service .

## **2.7 Summary**

Chapter 2 began by stressing the need for the electricity utilities to adopt load management policies . The utilities approach to implementing these polices was described in the form of load control and multiple tariff rates . The strategy behind the derivation of multiple tariff rates in relation to the 'electricity pool' was then discussed . With future metering systems in mind an investigation into the 'intelligent' meter then followed .

Section 2.3 provided a case study of a portion of MANWEBs' mid Mersey distribution network , from which approximate numbers of consumers , distribution substations and primary substations could be obtained . This study provided a basis from which to estimate the expected data rates involved in implementing a PLC based remote meter reading system . A communication system operating on both the LV and the MV networks using a through transformer signalling was analysed .

The significance of the data rates derived in this chapter will become apparent in the concluding chapters of this thesis . By analysing the distribution transformers' frequency characteristics , from the experimental results , it will be possible to establish achievable through transformer signalling rates . The degree of service possible in a given network architecture will therefore be predictable . Before this is possible it remains necessary to investigate the signalling characteristics of both LV and MV networks , together with the modulation techniques employed in PLC systems . These topics will be analysed in chapters 3 and 4 respectively .

## **Chapter 3 The LV and MV Network as a Communications Medium**

With the realisation that the use of the mains distribution network , as a means to convey information , is a feasible option , its high frequency behaviour must be understood . The following chapter draws on data obtained from studies undertaken by several research groups and presents a series of conclusions . Chapters 5 and 6 will then use these conclusions in conjunction with the data rates derived in chapter 2 , to determine the appropriate modulation schemes ( discussed in chapter 4 ) which will convey the required data quantity under certain channel conditions .

### **3.1 Signalling Standard**

Upon examining the characteristics of low and medium voltage networks, regarding their PLC signalling properties, an operating frequency range must firstly be established . Referring to the European standard EN 50065-1 [25], developed by the European Committee for Electrotechnical standardisation (CENELEC), a specification for signalling on low voltage electrical installations has been produced. This specification limits PLC signals to the frequency range 3 kHz to 148.5 kHz. The upper limit of this frequency range has been imposed as a preventative measure against PLC electromagnetic radiation interfering with long wave radio transmissions. This particular frequency range has also been divided into four frequency bands , each being designated for a particular use.

The following table summarises these bands.

| Band Allocation           | Frequency Range    | Application           |
|---------------------------|--------------------|-----------------------|
| Electricity Utility       | 3kHz to 95kHz      | Utility Communication |
| In Building Communication | 95kHz to 125kHz    | Non Access Protocol   |
| In Building Communication | 125kHz to 140kHz   | Access Protocol       |
| In Building Communication | 140kHz to 148.5kHz | Special Services      |

Table 3.1: Frequency Bands

The implications of this standard are that investigations carried out by this research may be restricted to the frequency range 3kHz to 148.5 kHz.

### 3.2 The Distribution Network as a Transmission Line

In using the mains distribution network for the purpose of conveying higher frequency signals, it is the cables which provide the signal path for the PLC . When the length of these cables becomes a significant portion of the signals wavelength , the cables may be deemed 'electrically long' . In these cases certain aspects of transmission line theory must be applied to distribution network elements .

#### 3.2.1. Transmission Line Theory

A transmission line consisting of parallel conductors may be modelled in segments as shown in the following diagram .

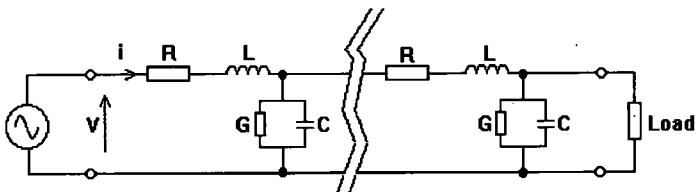

Fig 3.1: Transmission Line Model .



Where:  $R+j\omega L =$  Series Impedance per unit length and ,  
 $G+j\omega C =$  Shunt admittance per unit length .

If we represent the phasor ratio between voltage and current at any point along the line as the term 'Characteristic Impedance' (  $Z_c$  ) then from the cable parameters we express  $Z_c$  by the formula ( equation 3.1 ) .

$$Z_c \equiv \sqrt{\frac{R + j\omega L}{G + j\omega C}} \quad 3.1$$

The expression for  $Z_c$  implies that at radio frequencies the resistive components will become insignificant compared the reactive components . However in the audio range the resistive components are significant , resulting in a complex characteristic impedance .

### **3.2.2. Standing Waves**

If we assume that a transmission cable is lossless , and if all the power transmitted by the generator is to be absorbed by the load , then the load impedance (  $Z_L$  ) must be equal to the complex conjugate of the cables' characteristic impedance (  $Z_c$  ) .

If this is not the case then not all the power is absorbed by the load , the rest is 'reflected' back to the generator . This inefficiency increases as does the difference between  $Z_c$  and  $Z_L$  . These reflected voltage and current waves are known as 'standing waves' and add and subtract from the transmitted waves along the length of the cable . This leads to voltage and current maxima and minima . The ratio of the maxima and minima is termed the 'Standing Wave Ratio' (  $SWR$  ) . Hence the value of  $SWR$  is representative of the mismatch between the cable and the load .

The standing wave ratio is an important parameter of any transmission system . In the case of the distribution network , standing waves will be produced by a variety of network elements which include the following .

- ◆ Cable to receiver mismatch
- ◆ Cable joints
- ◆ Cable junctions
- ◆ Cable to transformer connections
- ◆ Loads

In the following sections the effect of these mismatches will be discussed .

i. Cable to receiver mismatch:

As previously discussed , in order for all the signal power to be transferred from transmitter to receiver , the cables characteristic impedance must be equal to the input impedance of the receiver . Although a receiver input impedance may be designed as a constant , it has been found that cable impedance's differ due to the cables construction and specification . The mismatches between cables and receivers will consequently give rise to reflected waves .

ii. Cable Joints:

The physical construction of a cable joint gives rise to wave reflections and hence standing waves . This is because as the cores within a joint separate , the inductance 'L' increases and the capacitance 'C' decreases . Thus the characteristic impedance  $Z_c \left( \sqrt{\frac{L}{C}} \right)$  increases , producing a reflection . Conversely , as the cores come together to exit the joint the characteristic impedance decreases , producing a further reflection .

### iii. Cable Junctions:

When a main feeder cable supplies spur cables a high frequency signal will encounter a junction along its signal path .

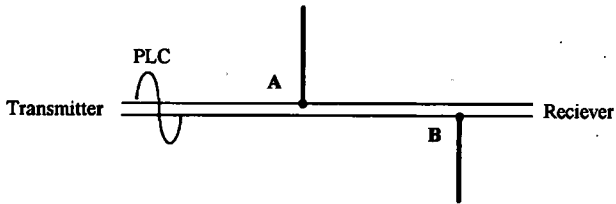

Fig 3.2: Reflection at Cable Junctions .

Here the PLC signal will 'see' a certain impedance at junction 'A' and at junction 'B' . This impedance , and hence the magnitude of reflected wave will depend upon the length of spur 'A' and spur 'B' together with the loads connected to the spur cable .

Analysis of such behaviour in greater detail is beyond the scope of this particular research .

### iv. Cable to Transformer Connections:

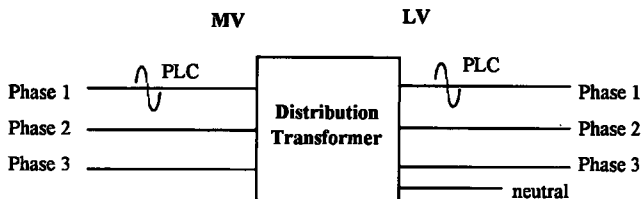

Fig 3.3: Reflections at Transformer .

In the case of connections between MV cable and distribution transformer , and LV cable and distribution transformer , an impedance mismatch will occur between the cables 'characteristic' impedance and the input / output impedance of the transformer . Yet again , these mismatches will give rise to reflections and standing waves . Although the cables characteristic impedance is generally a predictable and measurable quantity , the

impedance of transformers remain more difficult to define . Therefore section 3.5 will provide a more detailed analysis of the variation in transformer impedance's .

#### v. Loads:

As well as shunting a signal , as will be discussed later , a load connected between phases or between phase and neutral will produce a reflection due to the cable / load mismatch . Due to the unpredictable nature of loads , analysis remains impossible without the application of statistical techniques as performed by A.G.Burr [1] .

On a mains distribution network all these mismatches and reflections will occur simultaneously , thus giving rise to high standing wave ratios at particular locations and frequencies . The whole area of transmission line theory and its applicability to the mains distribution network lends itself to an entire area of research which is beyond the scope of this particular research . The previous discussions provide a basis for considering the effects which network elements have on transmission wave reflections , but of course do not provide a basis for calculating the effects of such elements . A more rigorous approach to the application of transmission line theory to distribution networks is provided by J.D. Suh [2] and A.G. Burr [1] .

### **3.3 Elements of a Distribution Network**

Before analysing the distribution network elements in greater detail it is necessary to examine the MV/LV network more closely . With reference to Fig 1.1 of chapter 1 , the distribution network which extends from the 33kV / 11kV transformer (box 4) to the 240/415V consumer network may be expanded .

Fig 3.4 illustrates the distribution network configuration from the Primary substation (33kV / 11kV) , down to the 240V / 415V consumers . The primary substation utilises a 'Delta / Star' transformer to step the voltage down from 33kV to 11kV . The

11kV feeders are used to supply the distribution substations and 11kV industrial loads . The distribution substation contains a 'Delta / Star' transformer to provide a 'step-down' in voltage from 11kV to 240V / 415V . An important characteristic of the distribution network is the length of feeders between transformers and loads . In the case of the MV network , distances up to tens of kilometres are encountered , whereas on the LV network distances in the region of up to hundreds of metres are the norm .

These cable lengths imply that distribution network feeders will be electrically long in the frequency range of interest .

For example , using the formula:

$$\text{Wavelength } (\lambda) \equiv \frac{\text{Velocity of Propagation } (v)}{\text{Frequency } (f)} \quad 3.2$$

$$\text{Where velocity of propagation } (v) \equiv \frac{v_s}{\sqrt{\epsilon}}$$

and  $v_s$  = velocity of light in free space ( 300 m /  $\mu$ s )

$\epsilon$  = relative permittivity of cable dielectric

Typical values of  $v$  , range from 150 m /  $\mu$ s to 280 m /  $\mu$ s [3] .

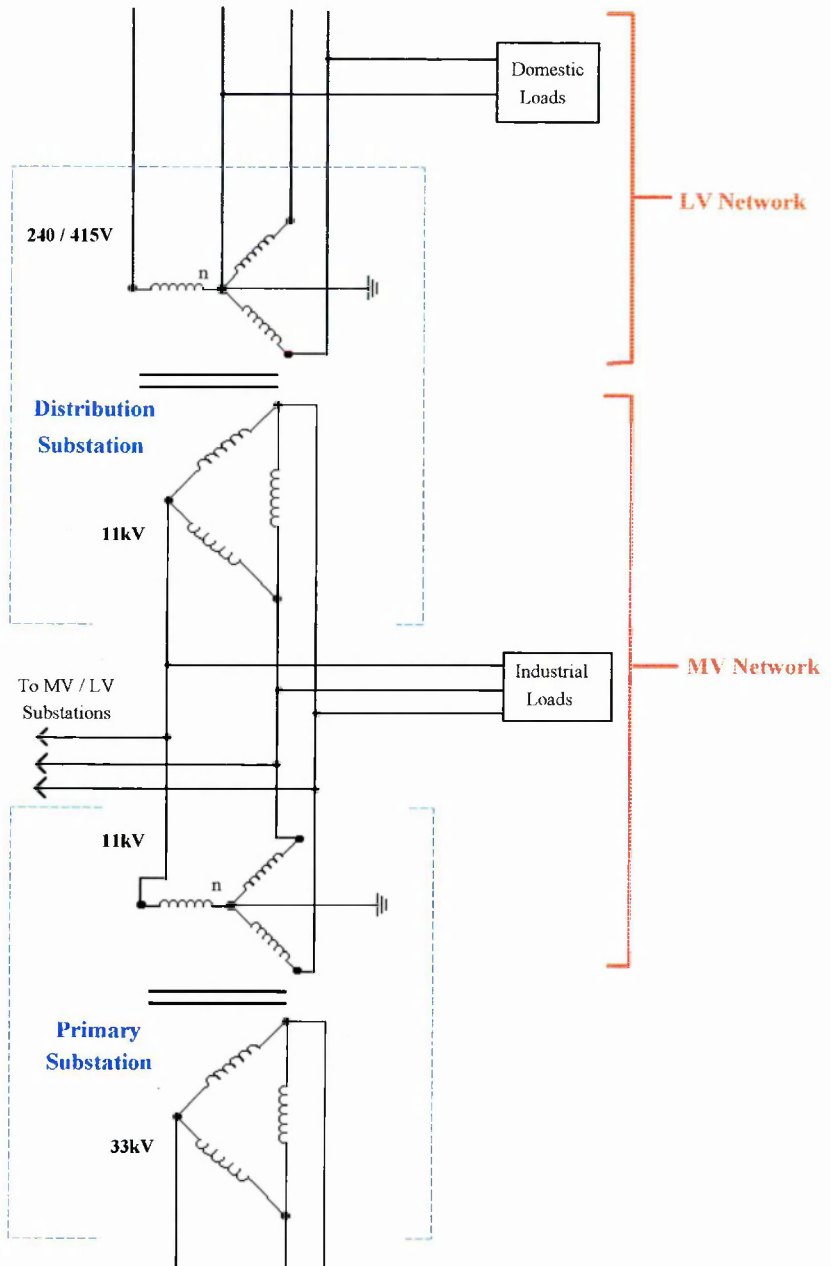

Fig 3.4: Distribution Network

These give rise to a range of wavelengths which depend upon cable type and frequency of operation . If the two extremes of a high propagation velocity with low signalling frequency and a low propagation velocity with high signalling frequency are considered the following wavelengths result .

$$\lambda_{\text{high}} \equiv \frac{2.8 \cdot 10^8}{3 \cdot 10^3} \approx 93\text{km} \quad \text{and} \quad \lambda_{\text{low}} \equiv \frac{1.5 \cdot 10^8}{150 \cdot 10^3} \approx 1000\text{m}$$

Of course in practice , wavelengths between these two extremes will be encountered which indicate that in some cases , feeders on MV networks will exhibit transmission line phenomena and must therefore be analysed with this in mind . However , the shorter distances involved on the LV distribution network result in the unlikely occurrence of reflections and standing waves .

**3.3.1 Cables**

The construction of power distribution cables in the UK distribution system varies considerably . Factors such as voltage rating , current capacity and age greatly influence their design . British standards designates cables in the following voltage ratings [12] .  
 600 / 1000V ( for LV distribution ) , 1900 / 3300V , 3800 / 6600V , 6350 / 11,000V ( for MV distribution ) , 8700 / 15,000V , 12,700 / 22,000V and 19,000 / 33,000V .

| <b>Cable Type</b>                          | <b>Characteristic Impedance</b> | <b>Information Source (Ref)</b> |
|--|---------------------------------|---------------------------------|
| MV 35mm <sup>2</sup> to 240mm <sup>2</sup> | <b>20Ω to 40Ω</b>               | [4]                             |
| LV 3Φ concentric neutral and Aerial cable  | <b>40Ω to 120Ω</b>              | [4]                             |
| U S LV triplex cable , line to ground      | <b>70Ω</b>                      | [5]                             |
| U.S AWG 12 / 2 line to neutral             | <b>98Ω</b>                      | [5]                             |

|   |       |      |
|---|-------|------|
| 185mm <sup>2</sup> Consec cable   | 12Ω   | [6]  |
| Alpex 300mm <sup>2</sup>  | 33Ω   | [7]  |
| Alpex 185mm <sup>2</sup>  | 34.5Ω | [7]  |
| Alpex 120mm <sup>2</sup>  | 38.6Ω | [7]  |
| Alpex 70mm <sup>2</sup>   | 38.3Ω | [7]  |
| Achrix / 32 , 3*150mm <sup>2</sup><br>at 50kHz                                  | 23.9Ω | [8]  |
| at 70kHz  | 23.8Ω | [8]  |
| at 90kHz  | 23.6Ω | [8]  |
| Ascorlx / 36 , 3*150mm <sup>2</sup><br>at 50kHz                                 | 31.8Ω | [8]  |
| at 70kHz  | 31.7Ω | [8]  |
| at 90kHz  | 31.6Ω | [8]  |
| Overhead MV cable<br>3*63mm <sup>2</sup> , 70kHz                                | 780Ω  | [8]  |
| 3*35mm <sup>2</sup> , 70kHz   | 816Ω  | [8]  |
| 3*8mm <sup>2</sup> , 70kHz  | 906Ω  | [8]  |
| 11 kV Aluminium 3 core<br>U-ground 95mm <sup>2</sup> line / line<br>at 10kHz    | 85Ω   | [9]  |
| at 100kHz   | 80Ω   | [9]  |
| 185mm <sup>2</sup> at 10kHz   | 75Ω   | [9]  |
| at 100kHz   | 70Ω   | [9]  |
| 'Modern' Aluminium cable<br>line / line at 20kHz                                | 12Ω   | [10] |
| at 150 kHz  | 9Ω    | [10] |
| 0.6 / 1.0kV belted cable<br>4 core stranded Aluminium<br>Size 25mm <sup>2</sup> | 18.2Ω | [3]  |



|  |       |     |
|--|-------|-----|
| Size 35mm <sup>2</sup>   | 16.7Ω | [3] |
| Size 95mm <sup>2</sup>   | 13.1Ω | [3] |
| Size 185mm <sup>2</sup>  | 12Ω   | [3] |
| 4 core stranded copper<br>Size 16mm <sup>2</sup>                         | 19.1Ω | [3] |
| Size 25mm <sup>2</sup>   | 18.2Ω | [3] |
| Size 70mm <sup>2</sup>   | 14Ω   | [3] |
| Size 120mm <sup>2</sup>  | 12.5Ω | [3] |
| 11kV belted cable<br>3 core stranded Aluminium<br>Size 95mm <sup>2</sup> | 24.8Ω | [3] |
| Size 185mm <sup>2</sup>  | 21Ω   | [3] |
| Size 300mm <sup>2</sup>  | 18.5Ω | [3] |
| 3 core stranded copper<br>Size 70mm <sup>2</sup>                         | 27.1Ω | [3] |
| Size 120mm <sup>2</sup>  | 21Ω   | [3] |
| Size 185mm <sup>2</sup>  | 21Ω   | [3] |

Table 3.2: Cable Characteristic Impedance .

**Note:**

Data from reference [8] ; The MV overhead cable is measured in line to line mode ( data available for line to earth mode , generally in line to earth mode ZC is less by approx. 2/3) .

Table 3.2 provides a listing of power distribution cables used on the LV and MV networks . Although by no means exhaustive , it lists some of the more 'common' types of cables used , together with their respective characteristic impedance . In some cases the frequency at which the characteristic impedance was measured is unknown . Several conclusions may be drawn from these findings .

- ◆ Variation in frequency provides only slight variations in characteristic impedance .
- ◆ Cables produced by the same manufacturer , but of differing cross sections possess marginally different characteristic impedance's .
- ◆ The greatest variation in characteristic impedance occurs between cables produced by different manufacturers . In extreme cases characteristic impedance may be several times smaller or greater from one cable type to another .

The implications of these findings are that because the distribution network consists of cables produced by different manufacturers using different materials and cable sizes , differing characteristic impedance's will be encountered . The presence of joints connecting cables of unequal characteristic impedance is therefore inevitable . This will give rise to undesirable reflections and standing waves which in turn reduces signal transmission efficiency .

The cables characteristic impedance may also be modified due to the cables surrounding environment . A cable entering the ground from the surface will have its characteristic impedance modified due to the surrounding ground . Also underground cables entering waterlogged zones have modified characteristic impedance . All these factors give rise to further reflections and standing waves .

Another parameter of the distribution cables which is particularly relevant to their use as PLC channels is that of attenuation . Table 3.3 provides a listing of distribution cables together with their respective attenuation , quoted in decibels per kilometre . Results indicate that attenuation as expected , increases with frequency and varies considerably between cables of differing types and sizes . Differences in attenuation rates range from 0.5 dB / km up to 12dB / km depending upon cable construction . Although these levels of attenuation may appear significant over distances in the region of kilometres , it will become apparent that such attenuation levels may be considered insignificant when compared with other network elements such as loads .

| <b>Cable Type</b>  | <b>Attenuation Level</b> | <b>Information Source (Ref)</b> |
|--|--------------------------|---------------------------------|
| MV 35mm <sup>2</sup> to 240mm <sup>2</sup><br>terminated with Zc<br>at 20kHz     | 1.5dB / km               | [4]                             |
| at 200kHz  | 5dB / km                 | [4]                             |
| LV 3Φ concentric neutral<br>and Aerial cable ,<br>terminated with Zc<br>at 20kHz | 2dB / km                 | [4]                             |
| at 200kHz  | 10dB / km                | [4]                             |
| 185mm <sup>2</sup> Consac cable  | 5dB / km                 | [6]                             |
| Alpex 300mm <sup>2</sup>   | 7.1 dB / km              | [7]                             |
| Alpex 185mm <sup>2</sup>   | 7.2dB / km               | [7]                             |
| Alpex 120mm <sup>2</sup>   | 12dB / km                | [7]                             |
| Alpex 70mm <sup>2</sup>  | 8.2dB / km               | [7]                             |
| Achrix / 32 , 3*150mm <sup>2</sup><br>at 50kHz                                   | 3.7dB / km               | [8]                             |
| at 70kHz   | 3.7dB / km               | [8]                             |
| at 90kHz   | 3.5dB / km               | [8]                             |
| Ascorlx / 36 , 3*150mm <sup>2</sup><br>at 50kHz                                  | 3.4dB / km               | [8]                             |
| at 70kHz   | 3.9dB / km               | [8]                             |
| at 90kHz   | 4.0dB / km               | [8]                             |
| Overhead MV cable<br>3*63mm <sup>2</sup> , 70kHz                                 | 0.03dB / km              | [8]                             |
| 3*35mm <sup>2</sup> , 70kHz  | 0.037dB / km             | [8]                             |
| 3*8mm <sup>2</sup> , 70kHz   | 0.072dB / km             | [8]                             |

|  |            |      |
|--|------------|------|
| 11 kV Aluminium 3 core<br>U-ground 95mm <sup>2</sup> line / line<br>at 10kHz | 0.5dB / km | [9]  |
| at 100kHz  | 1.5dB / km | [9]  |
| 185mm <sup>2</sup> at 10kHz  | 0.5dB / km | [9]  |
| at 100kHz  | 1.5dB / km | [9]  |
| MV Overhead Cable  | 3.7dB / km | [11] |

Table 3.3: Cable Attenuation .

**Note:**

Data from reference [8] ; The MV overhead cable is measured in line to line mode ( data available for line to earth mode ) .

**3.3.2. Capacitor Banks**

On the distribution network capacitor banks are installed in series and parallel arrangements .

**i. Series Capacitors:**

Although series capacitor compensation is a generally accepted technology for extra high voltage networks , it is becoming more accepted on lower voltage networks [13] .

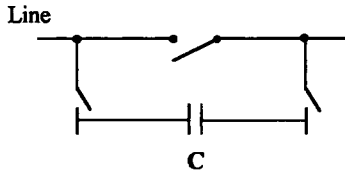

Fig 3.5: Series Capacitor Compensation .

Fig 3.5 illustrates how a series capacitor on a distribution line feeder introduces compensation for the reactive voltage drop of the feeder . This form of compensation is of limited use because under fault conditions the capacitor must withstand heavy currents causing possible damage . For this reason series capacitors used as voltage regulators are

not in widespread use . Due to their very low reactance at PLC frequencies series capacitors do not pose significant attenuation to distribution line carrier signals .

Manufacturers data [8] reveals a series impedance of around  $3.5\Omega$  at  $10\text{kHz}$  to approximately  $0.5\Omega$  at  $100\text{kHz}$  . Between these two frequencies impedance drops to around  $0.1\Omega$  due to the high capacitance with its small internal inductance causing resonance .

## ii. Shunt Capacitors:

Shunt capacitors are placed in parallel with the load or at a substation bus . Their primary operation is concerned with voltage regulation in the form of power factor correction .

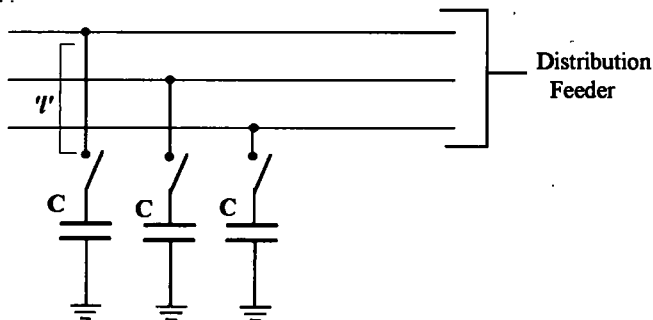

Fig 3.6: Shunt Capacitor Compensation .

The power factor correction capacitors in Fig 3.6 are designed to switch on at times of heavy loading . The current drawn will possess a leading power factor which compensates for heavy inductive loads , to achieve unity power factor .

Results from investigations [4] have revealed that MV capacitors , for reactive power compensation , installed in HV/MV or MV/LV substations provide a very selective resonance ( low impedance ) at around  $50\text{ kHz}$  . This resonance will pose a problem to carrier signals operating at this frequency , as the carrier signal will be shunted to ground . The resonant point of these capacitors may be shifted by introducing an electrical

connection of length 'l' between capacitor and line feeder . Measurements have shown that a connection length of 1.5m shifts the resonance downwards in frequency to around 30kHz . In practice these external connections are longer and will therefore shift the resonance even lower in frequency to a point outside the operation of PLC systems .

Conclusions drawn from these investigations reveal that LV capacitor banks produce similar resonance's and that provided the carrier frequency of the PLC system avoids this resonance , propagation of will not be significantly impeded .

### **3.3.3. Voltage Regulators**

Voltage regulators are devices used to hold the voltage of a distribution circuit at a pre determined value , within accepted tolerance values for distribution purposes . They may be installed on distribution feeders , on poles , pads or platforms . Voltage regulators are essentially auto transformers with the secondary portion of the coil arranged so that all or part of its induced voltage can be added or subtracted from the line or incoming primary voltage .

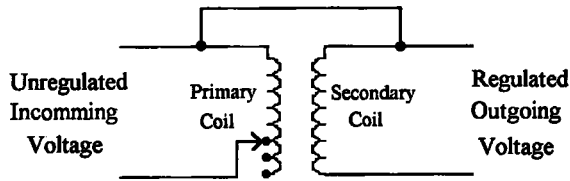

Fig 3.7: Voltage Regulator .

Fig 3.7 is typical of a step type regulator . It changes voltages by means of taps in the primary coil . The portion of the coil with taps has arrangements included for reversal in its connections so that the voltage within that portion of the coil may be added or subtracted from the rest of the primary coil .

It is evident that the inclusion of such a device on a distribution feeder will modify the propagation of a high frequency PLC signal . The effect such a device will have is dependant upon its frequency response characteristics . Unfortunately information on such parameters is of yet unavailable and would require further research . As research has been limited to investigations involving distribution transformers , one can only speculate that voltage regulators would provide extremely varied propagation characteristics which differ from regulator to regulator over the frequency range of interest .

### 3.3.4. Lightning Arresters

The function of a lightning , or surge arrester is to provide a path for surges in voltage , caused by lightning , to ground . They are designed to provide a lower impedance path to ground than that presented by the line or equipment .

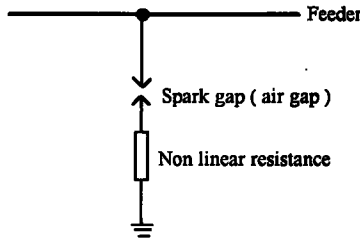

Fig 3.8: Surge Arrester .

An arrester consists of an air gap in series with an element which has the special characteristic of providing a relatively low resistance or impedance to the current produced by a high voltage surge . This non linear resistance will then provide a high impedance to the flow of power current at the distribution line voltage .

Unfortunately the specifications of such devices do not normally include their capacitance , which would primarily be due to the spark gap . This capacitance may well provide a low impedance path to ground for a high frequency PLC signal . The degree of attenuation the arrester would provide to the carrier signal will also be governed by the

impedance of the non linear resistance at carrier frequencies . This additional unknown parameter invites further research into the surge arresters high frequency characteristics , which at this stage is beyond the scope of this particular research .

### **3.4 Loads**

When considering the mains distribution network as a communications medium , a load may be defined as any installation which when connected to the network will shunt the high frequency signal to ground . Loads may be categorised into several types according to their reactive or resistive nature , namely , capacitive , resistive and resonant. The following section will determine which appliances may be placed in these categories and how they effect the propagation of high frequency carrier signals .

#### **3.4.1 Capacitive Loads**

An installation with very light loads , or no appliances connected appears as a capacitive load . This is largely due to the capacitive nature of the house wiring . Studies undertaken [1] have revealed values of 10nF as typical of consumer installations . Other loads such as filament lamps may appear as a mixture of resistance and capacitance . Research by Vines [14] draws attention to the capacitor connected between the power cord conductors , in television sets , of approximately 0.1 $\mu$ F . Considered in isolation it appears as purely capacitive , however if the inductive effects of the mains cabling connected to it are added , a resonant load is produced . A similar effect is produced by street lamps . In the case of street lighting , the power factor correction capacitor ( $\approx 8\mu$ F) placed between the live and neutral conductors causes a series resonance with the cables feeding it .

Further research by O'Neal [15] reveals the phenomenon of 'impedance modulation' produced by rectifier circuits . This effect occurs when a rectifier turns on (



either once or twice during a 50Hz cycle ) it places a large capacitor directly across the power circuit . The impedance 'seen' by a high frequency carrier signal will therefore change at a 50Hz or 100Hz rate . Since the signal voltage is developed across this time varying impedance it becomes amplitude modulated at 50Hz or 100Hz .

In summarising the effect of the capacitive load provided by a consumer installation , it has been found that the admittance increases linearly with frequency from around 4mS at 1kHz to approximately 10mS at 150kHz , see fig 3.9 . Although resistive and inductive loads are more common , capacitive loads can rarely be considered in isolation as the inductance of connected wiring produces resonance's .

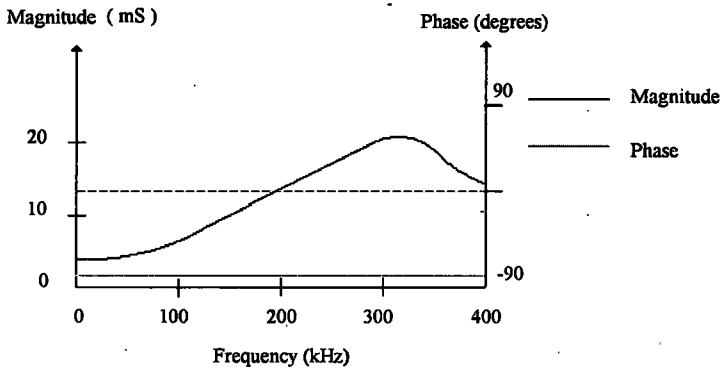

Fig 3.9: Admittance of Consumer installation ( no appliances connected ) .

### 3.4.2 Resistive Loads

Resistive loads may be attributed mainly to electric heating elements such as convector heaters , electric cookers and incandescent lighting . Their resistance is proportional to their power frequency rating  $\left( R \equiv \frac{V^2}{P} \right)$  where V = voltage (volts) and P = power (watts) .

Purely resistive loads will produce a constant admittance at PLC frequencies , the magnitude being dependant upon the power rating of the load . Obviously the higher the

power rating of the appliance , the smaller the resistance , and hence greater shunting of the carrier signal . For example a 2kW convector heater may be represented as a resistance of  $\approx 30\Omega$  . This load will effectively act as a load which shunts the high frequency PLC signal between live and neutral .

In practice a load of pure resistance rarely occurs , as electric heating loads usually poses inductance in series with a resistance . Due to the inductances' low reactance at low frequencies , a peak in admittances occurs at lower frequencies with a magnitude related to the inductance of the load limited by the series resistance . As the reactance increases with frequency , a 'roll off' in admittance proportional to frequency occurs at higher frequencies . Fig 3.10 is typical of such an admittance curve for a 7kW heating element .

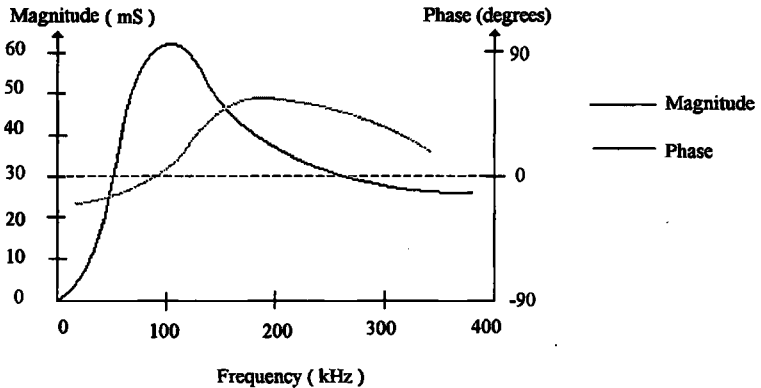

Fig 3.10: Admittance of 7kW resistive / inductive load .

### 3.4.3 Resonant Loads

A resonant load is produced by wiring inductance forming a series resonant circuit with any capacitors within an appliance or installation . Capacitances are usually due to interference suppression or power factor correction capacitors . These types of loads may be characterised by three parameters , namely Peak admittance (  $Y_o$  ) , Resonant frequency (  $f_o$  ) and Q factor . If loads which possess a resonant frequency within the frequency range of interest are considered ( $\approx 3\text{kHz}$  to  $150\text{kHz}$ ) , the peak admittance will

reflect the effect the load will have on the carrier frequency propagation . Studies have found [13],[7] that peak admittances as high as 1.5S are produced by resonant loads . This value of admittance is many times greater than the cables characteristic impedance , which results in severe attenuation . Table 3.4 provides a summary of resonant loads , listing their parameters .

| Load Type        | Resonant Frequency | 'Q' Factor | Peak Admittance |
|------------------|--------------------|------------|-----------------|
| Hi Fi            | 70kHz              | 3          | 1 S             |
| Television       | 110kHz             | 8          | 1 S             |
| Television       | 120kHz             | 3          | 0.8 S           |
| Television       | 130kHz             | 5          | 0.8 S           |
| Hi Fi            | 30kHz              | 1.7        | 0.5 S           |
| Freezer          | 140kHz             | 2.5        | 0.4 S           |
| Clock Radio      | 140kHz             | 3          | 0.34 S          |
| Washing Machine  | 50kHz              | 3          | 0.3 S           |
| Television       | 40kHz              | 2          | 0.18 S          |
| Television       | 80kHz              | 4          | 0.15 S          |
| Television       | 90kHz              | 5          | 0.15 S          |
| Fluorescent Lamp | 120kHz             | 6          | 0.11 S          |
| Television       | 90kHz              | 5          | 0.15 S          |

Table 3.4: Resonant Loads .

In table 3.4 the effect of the capacitor between live and neutral conductors , sited inside Hi Fi's and televisions , produces high values of peak admittance due to the series resonance with cable inductance . This causes televisions and Hi Fi's to be the worst 'offenders' in attenuating carrier signals .

In fig 3.11 the admittance of the resonant load may be represented graphically .

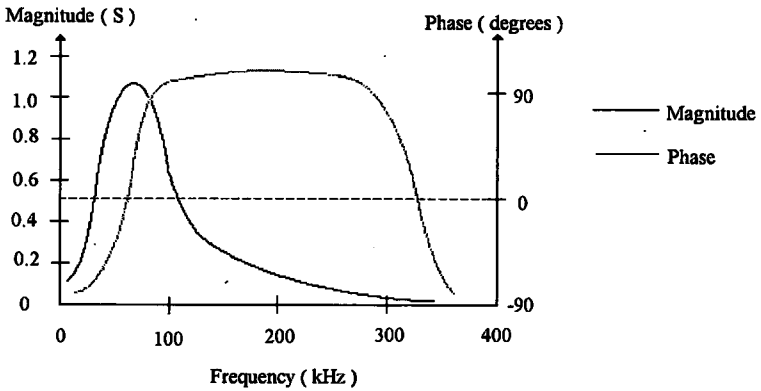

Fig 3.11: Resonant Load ( Hi Fi ) .

In comparison it can be seen the peak admittance of resonant loads is an order of magnitude greater than that of non resonant loads . Resonant loads cause considerable attenuation at their resonant frequency , producing a 'trough' in the distribution network propagation characteristics .

The severe attenuation caused by resonant loads dominates the effects of non resonant loads . Hence the effects of non resonant loads may be neglected in the presence of resonant loads .

One type of resonant load which requires special consideration is that of street lamps . As stated in section 3.4.1 , street lamps produce a large peak in admittance . The peak in admittance may be as high as 5S at 60kHz , or even greater if the combined effects of several street lights are considered . However the very nature of this type of load permits its behaviour to be predictable . Therefore a PLC system may have its carrier frequency sited in a portion of the frequency spectrum which avoids street light resonances .

## **Summary**

In summarising the combined effect of all load types , the dominating effect of resonant loads has been highlighted . The behaviour of these loads remains unpredictable in nature , as values of peak admittance and resonant frequency vary considerably from one load to another . Also the random nature of loads means that a deterministic model is impossible , therefore loads must be treated as a random variable and analysed by a statistical approach . This method of analysis results in propagation characteristics which at each point have a certain probability distribution rather than an absolute value .

## **3.5 Transformers**

The following section of this chapter is concerned with the results and conclusions involving the high frequency properties of distribution transformers , obtained from research previously undertaken . Although not exhaustive , the results of this literature search provide a basis for introducing the experimental work discussed in chapter five . With this in mind only a brief outline of transformer construction and layout will be provided at this stage .

### **3.5.1 Background**

The transformer is designed to transfer power between systems operating at different voltages . In reference to the power distribution network , transformers are used to transfer voltages from 33kV to 11kV and 11kV to 240 / 415 V . It is in the use of PLC systems that the performance of the 11kV to 240/415 V distribution transformer is of prime interest . Therefore investigations have been limited to transformers at this secondary distribution level . Picture 3.1 illustrates a transformer typical of this rating pictured inside a distribution substation located on MANWEBs' Mid Mersey network .



Transformers at this particular level are generally three phase and almost invariably double wound ( electrically separate primary and secondary windings ) . In three phase systems it is desirable that one of the transformer windings be of delta configuration in order to eliminate third harmonic currents . However , at the 240 / 415 V distribution level a neutral and earth potential conductor are also required , thus creating the necessity for a 'star' wound low voltage winding . Hence , transformers used at the 11kV to 240 / 415 V substation level are usually of delta high voltage winding and star low voltage winding .

In utilising a 'delta / star' winding arrangement the transformer introduces a phase shift to each of the three supply phases . The angle of phase shift is dependant upon how the HV delta windings are interconnected . Transformers used at the substation level are invariably of the 'Dy11' type . This terminology may be explained as follows .

'D' The upper case letter represents the type of HV winding , in this case delta .

'y' The lower case letter represents the type of LV winding , in this case star , or commonly known as 'wye' .

11 This figure refers to the vector representation of the induced emf , its significance will become clear after referring to the vector diagrams .

The HV and LV windings of a Dy11 type distribution transformer are electrically connected as follows .

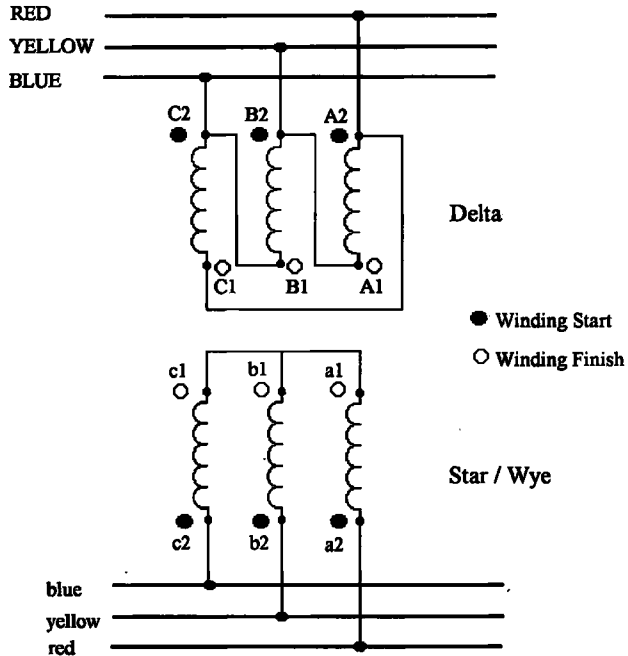

Fig 3.12: Dy11 Transformer Connections .

Fig 3.12 illustrates the electrical connections between coil windings which produce a Dy11 transformer . Because each of the HV phase voltages ( phases red , yellow , and blue ) are separated by an angle of 120 degrees , the interconnection of the delta winding

causes the induced emf on the same core / coil of the LV winding to be displaced by +30 degrees . That is the LV red phase leads the HV red phase by 30 degrees . This is illustrated by the following vector diagram .

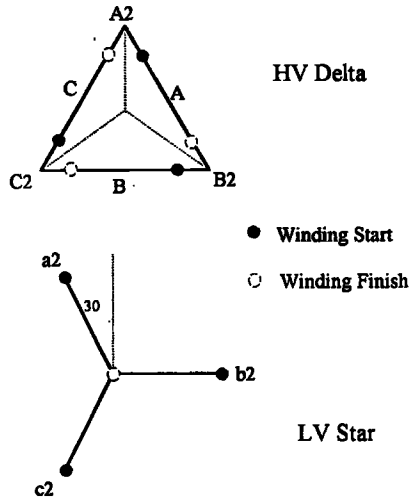

Fig 3.13: Dy11 Phase Vectors .

Referring to fig 3.13 , the HV phase voltage applied to the coil wound on core 'A' induces an emf on the LV winding of 'a2' . The vector representation illustrates how the LV vector of 'a2' leads the HV phase , which produces it , by 30 degrees ( vectors rotating in an anticlockwise direction ) . If the vectors in the LV star were placed on a clock face , the 'a2' vector would point to 11 O'clock . Hence the '11' represents a phase shift of +30 degrees . Different phase shifts may be introduced by rearranging the delta interconnections [16] .

Having described the electrical connections , the physical construction may be considered . With reference to fig 3.14 the majority of all distribution transformers are of the core type construction .



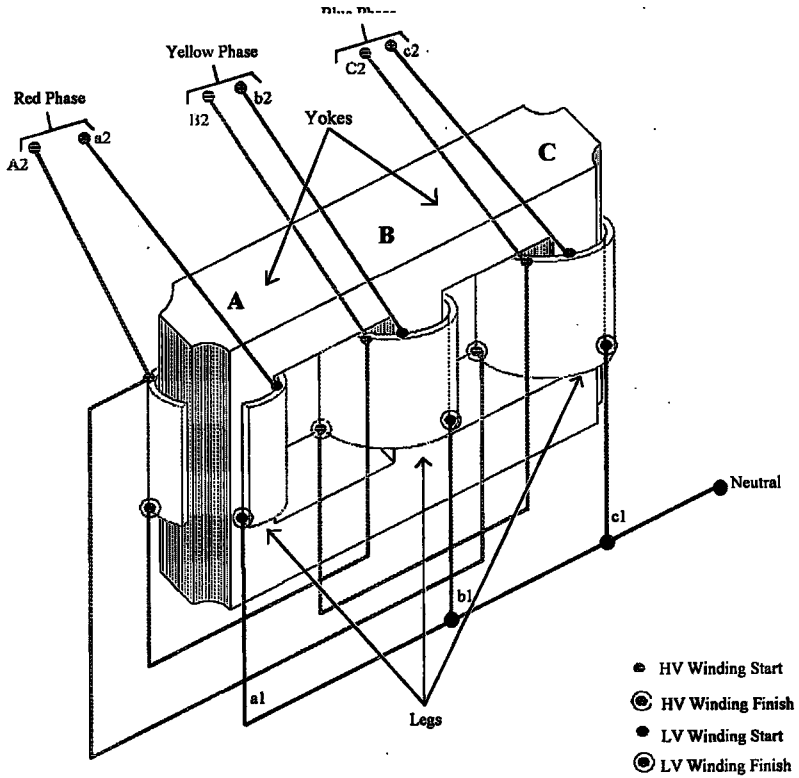

Fig 3.14: Dy11 Transformer Construction / Winding .

Here two concentric windings are wound on three 'legs' which form the three phases of the transformer . The magnetic circuit is completed by a return section or 'yoke' . Both legs and yoke are formed from laminations of cold rolled grain oriented steel of around 3% silicon content . The windings on each leg consist of an inner LV coil surrounded by an outer HV coil . With the windings connected as shown in fig 3.14 a Dy11 type transformer is produced .

Although only a brief introduction into transformer construction has been discussed , a more in depth study is provided by Stigent , Lacey and Franklin [16] .

### 3.5.2 High Frequency Operation

Having briefly discussed the construction and winding connections of the Dy11 transformer, its operation at PLC frequencies may be considered. As this topic forms the basis of this particular research, an in-depth study, together with experimental results, will follow in chapter five. Therefore the following section presents data obtained from a literature search.

#### i. Transformer input / output impedance :

If a transformer is considered as a 'black box' the following representation may be realised.

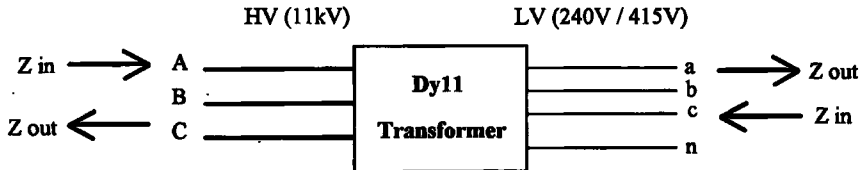

Fig 3.15: Transformer Representation .

A high frequency PLC signal which enters and leaves the transformer in either direction will 'see' a certain input / output impedance. This value of impedance will depend upon the mode of signalling used ( phase / phase, phase / neutral ). Research by Vines [5], Schroppel [4], Cortina [8] and Thorn EMI [10] reveal the impedance of the LV and MV windings is not modified by variations in load on the MV and LV side respectively. In other words the impedance of loads is not reflected through the transformer. This condition remains applicable at frequencies greater than approximately 30kHz.

From the published data which is available, it is only possible to obtain an approximate range of impedances which the transformer presents at its HV and LV

terminals . These impedances will obviously vary slightly between transformers of differing designs and ratings .

The following table summarises results obtained by Thorn EMI [10] .

| <b>Transformer Terminals</b> | <b>Transformer Power Rating</b> | <b>I/P Impedance at 20kHz(magnitude)</b> | <b>I/P Impedance at 150kHz (mag)</b> |
|------------------------------|---------------------------------|--|--------------------------------------|
| HV , Phase / Phase           | 50kVA                           | 6000Ω                                    | 800Ω                                 |
| HV , Phase / Phase           | 100kVA                          | 5000Ω                                    | 800Ω                                 |
| HV , Phase / Phase           | 200kVA                          | 4000Ω                                    | 800Ω                                 |
| HV , Phase / Tank            | 50kVA                           | 7000Ω                                    | 900Ω                                 |
| HV , Phase / Tank            | 100kVA                          | 10,000Ω                                  | 1500Ω                                |
| HV , Phase / Tank            | 150kVA                          | 5000Ω                                    | 700Ω                                 |
| LV Phase / Neutral           | 100kVA                          | 1500Ω                                    | 150Ω                                 |

Table 3.5a: Thorn EMI Transformer Impedance .

Measurements performed on a 160kVA , 15kV / 400V , MV / LV transformer by Schropfel [4] are shown in table 3.5 b .

| <b>HV , Phase / Phase</b> | <b>I/P Impedance at 30kHz</b> | <b>I/P Impedance at 150kHz</b> |
|---------------------------|-------------------------------|--------------------------------|
|                           | 1000 + j5000 Ω<br>5100∠79°    | 60 + j1000 Ω<br>1000∠86°       |

Table 3.5.b: Impedance Measurements by Schropfel .

The summary of results shown in tables 3.5.a and 3.5.b suggest in general that as frequency increases , transformer winding impedance decreases . This reduction in impedance may largely be attributed to inter winding capacitance . A important conclusion may be reached by comparing these impedance values with table 3.2 , which lists typical values of MV and LV cable characteristic impedance . One may conclude that the large difference between cable characteristic impedance and transformer input

impedance will result in severe mismatch . Consequently PLC signals aimed to propagate through a distribution transformer will undoubtedly suffer reflections , leading to high standing wave ratios .

ii. Transformer Attenuation:

The magnitude of attenuation which the transformer provides to a high frequency carrier signal is dependable on elements external to the transformer windings . Any degree of mismatch between transmitter , cable , transformer input and output impedance and load will introduce loss into the transmission path . For this reason the incomplete nature of information obtained from existing measurements makes assessments of results difficult and perhaps inconclusive . At this stage one may only state results and interpret them on their face value .

Measurements by Thorn EMI [10] , performed on 50kVA , 100kVA , and 200kVA transformers , yield the following range of results .

| <b>Signalling Mode</b>                         | <b>Lowest Attenuation</b> | <b>Highest Attenuation</b> |
|--|---------------------------|----------------------------|
| HV to LV , phase / phase<br>to phase / phase   | <b>-15dB</b>              | <b>-50dB</b>               |
| HV to LV , phase / phase<br>to phase / neutral | <b>-15dB</b>              | <b>-33dB</b>               |
| LV to HV , phase / phase<br>to phase / phase   | <b>0dB</b>                | <b>-20dB</b>               |
| LV to HV , phase / neutral<br>to phase / phase | <b>0dB</b>                | <b>-8dB</b>                |

Table 3.6.a: Thorn EMI Transformer Attenuation .

These may be compared with results obtained by Schroppel [4] from measurements performed on a 160kVA , 15kV / 400V transformer .

| <b>Signalling Mode</b>                          | <b>Mean attenuation , 10kHz to 100kHz</b> |
|---|---|
| <b>HV to LV , phase/ground to phase/neutral</b> | <b>Approx -50dB</b>                       |
| <b>LV to HV , phase/neutral to phase/ground</b> | <b>Approx -20dB</b>                       |

**Table 3.6.b: Attenuation Measurements by Schroppel .**

The results give rise to the following observations:

- ◆ The mean value of attenuation from HV to LV and LV to HV windings increases with frequency but varies considerably about its mean value . This is not surprising since as frequency approaches 50Hz the signal transfer ratios will equal the turns ratios of the transformer .
- ◆ Attenuation from HV to LV is more severe than LV to HV due to the 'step down' configuration of transformer windings .
- ◆ Levels of attenuation between 10kHz and 150kHz cover a dynamic range of up to 35dB due to 'troughs' and 'peaks' in propagation .
- ◆ In using the phase and neutral conductors as opposed to the phase and phase conductors , on the LV side , lower levels of attenuation are encountered .

From these observations it may be concluded that at frequencies above 20kHz high levels of attenuation are encountered in both directions . Conclusions by Schroppel [4] and ENEL [17] suggest at frequencies above 20kHz the transformer acts as a virtual signal block . Of course the ability of carrier signals to propagate through a transformer may be enhanced by adopting an appropriate modulation scheme . This approach will be discussed in detail in chapter four .

### 3.6 Total Network Impedance

Sections 3.3 , 3.4 and 3.5 have discussed the effects which individual network elements have on the propagation of high frequency signals . This section will consider the combined effects which these elements have on the impedance of the distribution network . The information published in this section is a tabulated summary of research undertaken by several research groups .

| Network Location                    | Frequency      | Impedance                   | Reference |
|-------------------------------------|----------------|-----------------------------|-----------|
| 240V Mains                          | 5kHz           | $1 + j2, (2.2)63^0 \Omega$  | [5]       |
| 240V Mains                          | 100kHz         | $16 + j22, (27)54^0 \Omega$ | [5]       |
| 240V Residential pwr circuit        | 100kHz         | 5 to $32 \Omega$            | [18]      |
| LV distribution network             | 20kHz          | $5 \Omega$                  | [19]      |
| LV distribution network             | 150kHz         | $13 \Omega$                 | [19]      |
| LV (OH&UG) Various sites            | 10kHz          | $4 \Omega$                  | [20]      |
| LV (OH&UG) Various sites            | 110kHz         | $13 \Omega$                 | [20]      |
| LV distribution network             | 20kHz          | $3 \Omega$                  | [21]      |
| LV distribution network             | 100kHz         | $25 \Omega$                 | [21]      |
| 240V Secondary Mains                | 10kHz          | 3 to $5 \Omega$ inductive   | [14]      |
| 240V Secondary Mains                | 100kHz         | 12 to $26 \Omega$ inductive | [14]      |
| Connection OH,MV line through cable | 50kHz to 65kHz | 10 to $40 \Omega$           | [4]       |
| MV,UG feeder,several site           | 30kHz          | $25 \Omega$                 | [20]      |
| MV,UG feeder,several site           | 90kHz          | $15 \Omega$                 | [20]      |
| Long OH,MV feeder,midpoint          | 50kHz to 65kHz | 200 to $400 \Omega$         | [4]       |

Table 3.7: Network Impedances .

The data presented in the table 3.7 lists the impedances measured at several frequencies over widely differing locations on both MV and LV networks located in various European countries . From this summary several observations may be made .

- ◆ The magnitude of impedance encountered on LV networks throughout Europe is similar .
- ◆ In general the impedance magnitude of the LV network increases with frequency due to its inductive nature . The exception to this rule occurs in the presence of capacitances in the micro Farad range . Here resonances occur causing impedance to fall to a minimum .
- ◆ In contrast the impedance of the MV network decreases with frequency and may vary by factors of up to 10 , depending on location .
- ◆ Studies carried out by the Electricity Association [21] reveal that impedances between phase / neutral , phase / earth and neutral / earth are similar up to frequencies of 150 kHz .
- ◆ Although the impedance of the LV distribution network is strongly influenced by loads , the MV network remains isolated from these effects by the distribution transformer . Hence impedance variations on the MV network may be attributed to transformers and capacitor banks and in some cases heavy loads from industrial consumers .

The conclusions which may be drawn from this study imply that a communication system which is connected to the distribution network will be heavily loaded by the low impedance of the network . Because heavy loading on the network reduces network impedance , especially in close proximity to the load , a transmitter placed near a heavy load will have its output signal severely attenuated by the shunting effect of the load . These factors suggest that a communications systems' transmitter should be capable of driving a very low impedance load , typically down to  $2\Omega$  .

### **3.7 Noise**

In a communications system noise may be defined as any unwanted introduction of energy tending to interfere with the proper reception and reproduction of transmitted signals . As far as the mains distribution network is concerned the noise present may be grouped into several categories , namely ,

- i. Background noise .
- ii. Smooth spectrum noise .
- iii. Synchronous noise .
- iv. Non synchronous periodic noise .
- v. Impulse noise .

These types of noise , together with their sources and effects will now be discussed further , and summarised in table 3.9 .

#### **3.7.1 Background Noise**

The background noise on the distribution network may be used as a basis to compare the levels of noise produced from other sources . Measurements by Smith [23] indicate background noise is typically gaussian in nature and decreases at approximately 25 to 30dB per decade at frequencies greater than 10kHz . Typical mean levels of background noise , reported by Vines [24] , in the region of 0.5mV rms seem to be normal on the LV distribution network . Similar levels of background noise measured by Schropfel [4] of around 1mV rms , throughout the range 50kHz to 250kHz , reinforce the results of Vines's study .

Measurements of background noise on the MV network by Formby [22] reveal a steady decrease in noise as frequency increases . Table 3.8 lists typical noise levels in different network environments .



| MV Network Environment ( noise level (rms) ) |            |            |          |
|--|------------|------------|----------|
| Frequency                                    | Industrial | Commercial | Domestic |
| 10kHz  | 7.5mV      | 4.3mV      | 3mV      |
| 100kHz                                       | 3mV        | 1.3mV      | < 0.5mV  |

Table 3.8: MV network noise levels .

As expected , MV networks feeding industrial areas exhibit a greater magnitude of background noise than those serving purely domestic areas .

The results of this investigation agree well with similar research by Schroppel [4] which places MV background noise in the range 2 to 7 mV rms .

### 3.7.2 Smooth Spectrum Noise

This type of noise may be modelled as white noise . Its spectrum is smooth without the presence of stationary spectral lines . Its power density may be deemed fairly constant over the frequency range of interest , consequently it may be characterised by its spectral density alone and not by any finite bandwidth . Fig 3.16 illustrates smooth spectrum noise .

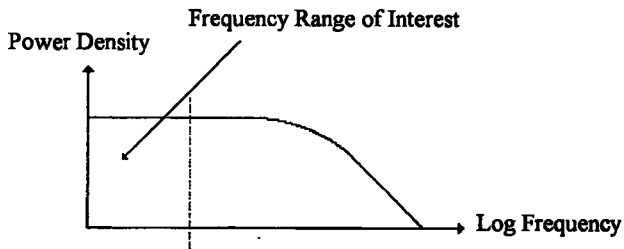

Fig 3.16: Frequency Spectrum of Smooth Spectrum Noise .

Smooth spectrum noise is caused by loads which do not operate synchronously with the power line frequency . Amongst the 'generators' of smooth spectrum noise are

universal motors which are usually present in 'hand held' devices such as drills , sewing machines , vacuum cleaners , mixers and blenders etc. It is the brushes within the motor which cause current switching impulses . These high frequency currents have spectra consisting of continually moving spectral lines proportional to motor speed . The noise voltage produced by this current spectra depends upon the impedance of the power line .

### 3.7.3 Synchronous Noise

Synchronous noise consists of line spectra located at multiples of the supply frequency ( 50Hz ) and is illustrated in fig 3.17 .

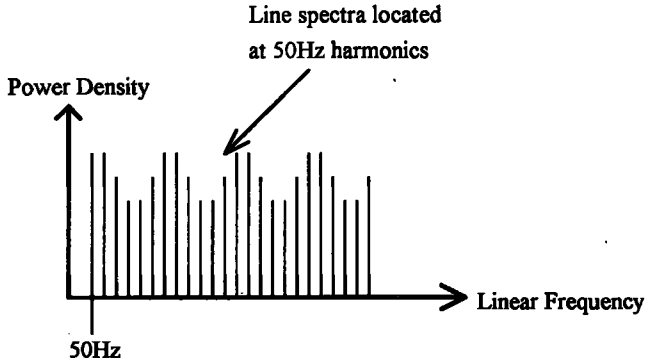

Fig 3.17: Synchronous Noise .

The principle causes of synchronous noise are devices which switch at the supply frequency , or multiples of it . In terms of the power line , SCR's are responsible for the majority of synchronous noise .

### 3.7.4 Non Synchronous Noise

This type of noise is produced periodically , but with a period which is unrelated to the 50Hz supply frequency . An example of this noise spectra is shown in fig 3.18 .

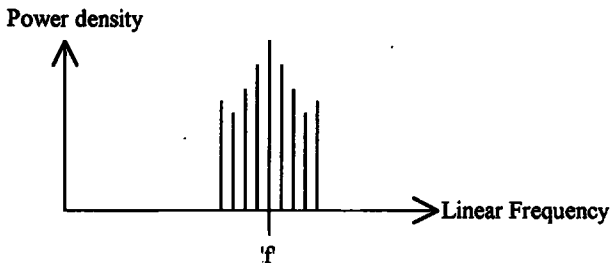

Fig 3.18: Non Synchronous Periodic Noise .

In fig 3.18 , spectral lines produced periodically about a fundamental frequency 'f' . Appliances responsible for producing non synchronous periodic noise are primarily televisions ( producing harmonics about the scan time base of 15.625kHz ) and switch mode power supplies which operate between 20kHz and 35kHz .

### 3.7.5 Impulse Noise

Impulse noise is non continuous consisting of irregular pulses or noise spikes of short duration and relatively high amplitude . The causes of such noise may be attributed to lightning and transients produced by switching phenomenon such as the switching in and out of capacitor banks , heavy loads and portions of the network . Analysis of this type of noise is very difficult due to its unpredictable nature . Hence , typical levels of its amplitude and frequency content are difficult to quantify . Research by Formby [22] and Chan [26] suggest a statistical approach in determining the occurrence of network impulses and transients .

### 3.7.6 Noise Summary

The following table summarises the levels of noise , relative to background noise ( section 3.7.1 ) , produced by various noise types emanating from various appliances common to the power distribution network .

| <b>Noise Type</b>              | <b>Typical Appliances/sources</b>                                   | <b>Noise Level (relative to background noise)</b> | <b>Reference</b> |
|--------------------------------|---|---|------------------|
| Smooth Spectrum Noise          | Universal Motors  | +30dB ( 31mV )                                    | [24],[15][14]    |
| Synchronous Noise              | SCR controlled motors,<br>Light dimmers                             | Up to +40dB ( 0.1V )                              | [24],[15][14]    |
| Non Synchronous Periodic Noise | Televisions,VCRs,<br>Switch mode power supplies                     | Up to +60dB ( 1V )<br>at fundamental frequency    | [24],[21]        |
| Impulse Noise                  | Capacitor banks,<br>heavy loads,<br>Network switching,<br>Lightning | Up to , and in excess of +40dB                    | [26],[24]        |

Table 3.9: Sources and levels of Noise .

The previous table reveals that non synchronous periodic noise is responsible for noise outputs of greatest amplitude . Noise outputs of up to 60dB greater than the 1mV background noise ( approx. 1V ) at fundamental frequencies may be present . These levels may be compared with the maximum permitted output of mains communications transmitters [25] which is fixed at 134dB  $\mu V$  ( approx. 5V ) .

Although transmission output levels may be several times greater , or even orders of magnitude greater , than typical noise levels , receivers sited in close proximity to high levels of noise may be adversely effected .

The studies also reveal that noise levels generally decrease with increasing frequency . This would suggest that a communications system operating at higher

frequencies would be less hindered by noise . Unfortunately , as will be made clear in section 3.8 , systems operating at higher frequencies suffer from more severe network attenuation .

As far as the noise types are concerned the synchronous and non synchronous noise types are 'predictable' in the sense that their frequencies are known and may thus be avoided . In the case of impulse noise its random nature means that carrier frequencies cannot be planned and arranged to avoid noise impulses . It is the modulation and encoding schemes which are responsible for providing immunity to such impulses and transients . Such noise spikes may completely obliterate message packets , therefore highlighting the need for suitable re transmission protocols or even broad band modulation techniques . Modulation techniques which are capable of dealing with such interference will be discussed in chapter four .

The noise output levels listed in table 3.9 , together with the signal to noise ratio required at the receiver input will give rise to the signal power ratio required at receiver input ( see equation 3.3 ).

$$\text{Signal to Noise Ratio ( S/N )dB} = 10 \log_{10} \frac{\text{Signal Power}}{\text{Noise Power}} \quad 3.3$$

With pre knowledge of transmitter output power , the maximum degree of attenuation for a particular transmission channel may be calculated . This implies that a certain amount of foresight into typical levels of attenuation , on mains distribution networks , is required . The next section of this chapter concerns itself with the attenuation levels encountered on a loaded mains distribution network .

### 3.8 Network Attenuation

In the previous sections the effects of network elements , loads , transformers , network impedance and noise levels have been considered on an individual basis . However , if the distribution network is to be utilised as a communications medium , then the effects of these components must be grouped together . The combined effect of these components may be quantified by the attenuation , which the distribution network as a whole , presents to a high frequency signal . This section presents a summary of research undertaken by several groups concerning the attenuation levels present on 'typical' distribution networks .

#### 3.8.1 Attenuation Levels

| <b>Location</b>             | <b>Time</b> | <b>Distance</b> | <b>Frequency</b> | <b>Atten (dB)</b> | <b>Reference</b> |
|-----------------------------|-------------|-----------------|------------------|-------------------|------------------|
| LV,U.G,ph/neutral           | -----       | 100m            | 20-120kHz        | <b>5 - 10dB</b>   | [4]              |
| LV,O.H,ph/neutral           | 1800-2200   | -----           | 100kHz           | <b>60dB</b>       | [4]              |
| LV,O.H,ph/neutral           | 2200-1000   | -----           | 100kHz           | <b>30dB</b>       | [4]              |
| LV,U.G,ph/neutral           | -----       | 500m            | 20-200kHz        | <b>30 - 45dB</b>  | [4]              |
| LV,U.G,ph/neutral           | 2200-1000   | 500m            | 100kHz           | <b>30dB</b>       | [4]              |
| LV,U.G,ph/neutral           | 1800-2200   | 500m            | 100kHz           | <b>60dB</b>       | [4]              |
| LV,O.H,ph/neutral           | -----       | 100m            | -----            | <b>10dB</b>       | [4]              |
| LV,O.H,ph/neutral           | -----       | 500m            | -----            | <b>30dB</b>       | [4]              |
| LV industrial & residential | Daytime     | 10m             | -----            | <b>2 - 8dB</b>    | [27]             |
| LV industrial & residential | Daytime     | >>10m           | -----            | <b>20 - 40dB</b>  | [27]             |
| LV low rise residnc         | Peak Load   | -----           | -----            | <b>20 - 30dB</b>  | [27]             |
| LV high rise flats          | Peak Load   | Short           | -----            | <b>10 - 20dB</b>  | [27]             |
| LV high rise flats          | Peak Load   | Long            | -----            | <b>35 - 55dB</b>  | [27]             |

|                                  |                         |                    |             |                    |      |
|----------------------------------|-------------------------|--------------------|-------------|--------------------|------|
| LV family house                  | 0000 - 0400             | -----              | -----       | <b>2 - 6dB</b>     | [27] |
| LV family house                  | <b>TV Load</b>          | -----              | -----       | <b>4 - 10dB</b>    | [27] |
| LV family house                  | <b>Elec kettle</b>      | -----              | -----       | <b>5 - 12dB</b>    | [27] |
| LV , OH & UG                     | <b>Various<br/>time</b> | 70 - 220m          | 10 - 110kHz | <b>35dB</b>        | [20] |
| LV , no loads                    | -----                   | 100m               | < 150kHz    | <b>0.5dB</b>       | [21] |
| LV , with loads                  | -----                   | 100m               | < 150kHz    | <b>10 - 25dB</b>   | [21] |
| LV , with loads                  | -----                   | 15 - 100m          | < 100kHz    | <b>0 - 40dB</b>    | [21] |
| LV , no loads same<br>phase      | -----                   | Adjacent<br>houses | 10kHz       | <b>4dB</b>         | [21] |
| LV , no loads same<br>phase      | -----                   | Adjacent<br>houses | 100kHz      | <b>10dB</b>        | [21] |
| LV , loads , same<br>phase       | -----                   | Adjacent<br>houses | 10kHz       | <b>5dB</b>         | [21] |
| LV , loads , same<br>phase       | -----                   | Adjacent<br>houses | 100kHz      | <b>22dB</b>        | [21] |
| LV , loads ,<br>alternate phases | -----                   | Adjacent<br>houses | 10kHz       | <b>12dB</b>        | [21] |
| LV , loads ,<br>alternate phases | -----                   | Adjacent<br>houses | 100kHz      | <b>20dB</b>        | [21] |
| LV , residential                 | <b>Afternoon</b>        | Varied             | 40kHz       | <b>30dB (best)</b> | [1]  |
| LV , residential                 | <b>Afternoon</b>        | Varied             | 120kHz      | <b>60dB, worst</b> | [1]  |
| LV , residential                 | <b>Evening</b>          | Varied             | 80kHz       | <b>95dB, worst</b> | [1]  |
| LV , residential                 | <b>Evening</b>          | Varied             | 100kHz      | <b>50dB (best)</b> | [1]  |
| LV , residential                 | 1700 hrs                | Varied             | -----       | <b>40dB(mean)</b>  | [1]  |
| LV Network                       | 1800 - 1900             | > 430m             | 20kHz       | <b>20dB</b>        | [28] |
| LV Network                       | 1800 - 1900             | > 430m             | 95kHz       | <b>70dB</b>        | [28] |
| MV Underground                   | -----                   | -----              | 50kHz       | <b>28dB</b>        | [4]  |
| MV Underground                   | -----                   | -----              | 100kHz      | <b>20dB</b>        | [4]  |

|                                      |                  |            |        |             |      |
|--------------------------------------|------------------|------------|--------|-------------|------|
| MV Underground                       | -----            | 400 -1600m | -----  | <b>25dB</b> | [4]  |
| MV,primary-sub<br>UG, ground / phase | Various<br>times | -----      | 30kHz  | <b>35dB</b> | [20] |
| MV,primary-sub<br>UG, ground / phase | Various<br>times | -----      | 90kHz  | <b>22dB</b> | [20] |
| MV,UG, various                       | -----            | 335m       | 10kHz  | <b>5dB</b>  | [22] |
| MV,UG, various                       | -----            | 335m       | 100kHz | <b>10dB</b> | [22] |

Table 3.10: Network Attenuation Levels .

Table 3.10 presents a summary of attenuation measurements . For each measurement several variables are present including the location , time of day , distance between transmitter and receiver and frequency of signal . In some cases specific information regarding these variables is not provided due to the nature of the experimental approach . This factor makes it difficult to draw specific conclusions from the data obtained from these measurements . However , several general summations may be made from these results .

- ◆ In all low voltage environments , attenuation increases as frequency increases .
- ◆ Attenuation on medium voltage networks decreases with increasing frequency . Although investigations by Formby and Adams [22] reveal otherwise .
- ◆ At peak load times ( late afternoon / early evening ) , attenuation in dBs increases by approximately a factor of two , [4] , [1] .
- ◆ The addition of loads increases attenuation , [27],[21] .
- ◆ Attenuation appears to double when transmitting and receiving on alternate phases , [21] .
- ◆ As expected , attenuation increases with distance .
- ◆ The attenuation levels , over the frequency range 10kHz to 150kHz , is extremely varied with peaks and troughs producing a dynamic range of up to 50dB .



- ◆ If the variables of location , time , distance and frequency are considered , a total dynamic range of up to 95dB is present on low voltage networks .

### **3.9 Summary**

The beginning of chapter 3 introduced the European standard EN-50065-1 ; which defines the boundaries of power line carrier signalling systems . This provided a specific range of frequencies over which the behaviour of low and medium voltage networks could be considered .

Sections 3.2 and 3.3 have used aspects of transmission line theory to analyse the high frequency behaviour of the distribution network and the elements of which it comprises . Following this analysis a study of loads and their effect on high frequency signal propagation took place . This study was reinforced by the results of research undertaken by several research groups .

In section 3.5 the construction of the distribution transformer was introduced , together with a brief review of its high frequency operation . This section highlights the need for further research on through transformer signal propagation and therefore provides a basis for introducing the main experimental work in chapter 5 .

Having considered all the individual components of the distribution network sections 3.6 , 3.7 and 3.8 studied their combined effect in terms of network impedance , noise and attenuation . Upon analysing the effects of all these factors the following conclusions may be made .

The electrical impedance of the low voltage distribution network varies enormously due mainly to the variable nature of loads connected to it . This is true for the medium voltage network , to a certain degree , but the effect of loads is less pronounced

due to the 'buffering' nature of the distribution transformer above 20kHz . However , transmission line effects are more prominent because of the longer length of distribution feeders . The effect of electrical noise , caused mainly by consumers appliances , is also apparent , but more so on LV networks .

Overall , the effects of varying impedances and differing noise levels lead to very large variations in network attenuation levels . The levels of attenuation at specific times and places are not clearly defined and require statistical analysis , as by Burr [1] . In order to cope with the harsh signalling environment of the LV network , and to a certain extent the MV network , a suitable modulation scheme must be considered . The trade-offs between available bandwidth , data rate , signal power and channel attenuation may now be studied in chapter 4 .

## **Chapter 4: Modulation Systems**

Upon examining the characteristics of the MV and LV networks , in the previous chapter , it became apparent that at certain frequencies high levels of attenuation exist . Under such circumstances it may well be impossible to reliably transmit an unmodulated 'baseband' signal .

For the efficient and effective transmission of information through a communication channel it is necessary to employ a carrier signal . The information is conveyed by the carrier in a process known as modulation . Modulation schemes may be classified into two groups , namely analogue and digital modulation systems . In analogue modulation systems a continuous waveform is used to continually vary one of the parameters of the carrier in synchronism with it . Analogue modulation may be broadly covered by amplitude modulation ( AM ) and its variants , and angle modulation together with its variants .

In terms of power line carrier signals modulation is necessary in order to 'shift' the spectrum of the baseband signal to a portion of the spectrum where signals may propagate more efficiently .

### **4.1 Effect of Modulation and Encoding**

Fig 4.1 illustrates the effect , in terms of signal spectrum , of encoding and modulating a stream of random digital data . This random digital data is typical of that generated by the remote metering systems and services of chapter 2 section 2.2 .

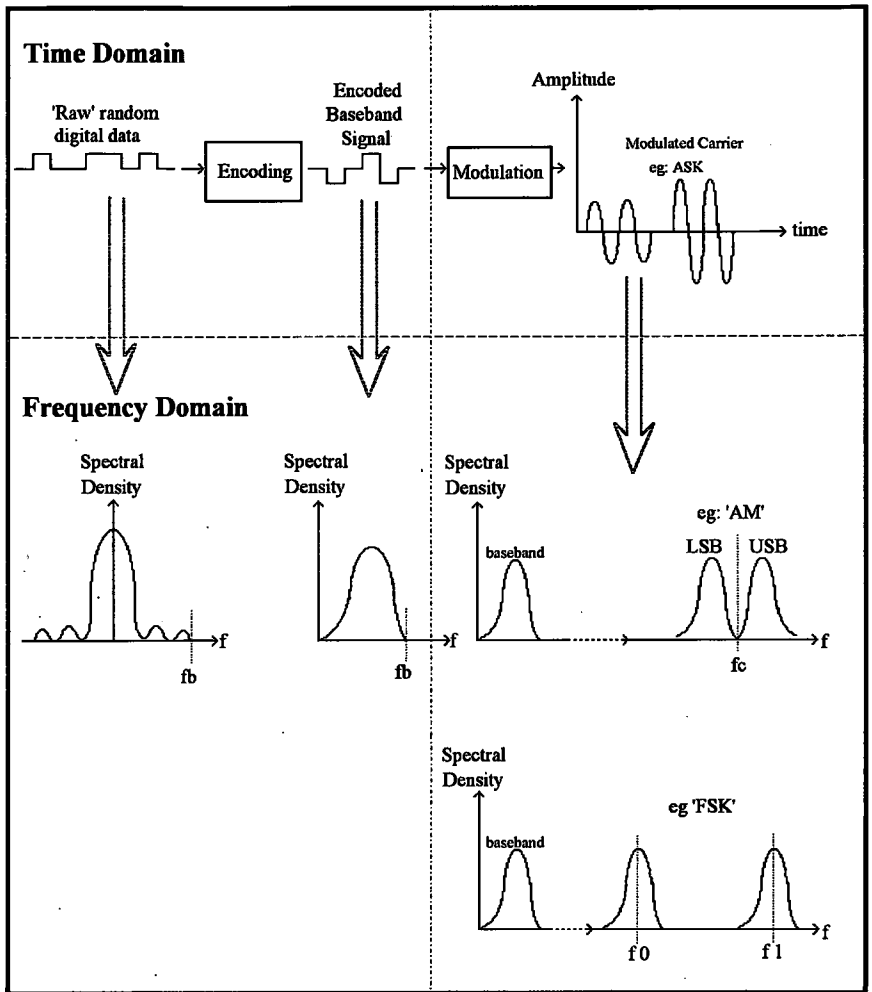

Fig 4.1: Effect of Encoding and Modulation .

Fig 4.1 may be split into portions , the upper half illustrates the uncoded , encoded and modulated signal in the time domain , whilst the lower section uses the frequency domain to represent the respective signal states . Beginning with the 'raw' digital data , a baseband frequency spectra which extends up to at least half the signalling rate is produced . Although this may well be immediately modulated , the process of encoding is

often employed . In encoding the raw data a 'new' baseband spectra is produced with spectral content a function of the form of encoding .

#### 4.1.1 Encoding

The example shown in fig 4.1 illustrates the use of 'alternate mark inversion' code ( AMI ) . This particular code has several advantages and disadvantages , depending upon its intended application . The use of encoding schemes in digital transmission systems may also be used to incorporate error correction schemes [66] , an in depth study of such schemes falls beyond the scope of this particular research project . For the current topic of discussion it remains necessary to note the following influences of encoding schemes .

- ◆ The number of signalling states used in a code is termed the codes 'radix' .
- ◆ It can be shown that the capacity of a noise free channel is related to the codes radix and may be determined by the 'Hartley' law .

$$\text{Channel Capacity ( bits / sec )} \equiv 2\delta f \log_2 N \quad 4.1$$

Where  $\delta f$  = Channel bandwidth ( Hz ) .

and  $N$  = Number of signalling states ( radix ) .

- ◆ From the previous equation , a higher radix code can convey more information per symbol .
- ◆ The disadvantages involved in employing a higher radix code are :
  - i) Extra complexity required in the encoding and decoding circuits .
  - ii) A decrease in signal to noise ratio because the signalling levels are closer together , thus increasing the error probability .
- ◆ However , an increase in information rate will permit a corresponding decrease in signalling rate ( if an equal quantity of information is to be conveyed over a given time ) . A lower signalling rate will therefore allow a more conservative use of bandwidth .

### 4.1.2 Noise

Practical results show a signal to noise ratio of 30dB ensures virtually error free reception when a binary code is used . This corresponds to a noise power of 1/1000 of signal power . If the signalling speed is doubled , by increasing the number of signalling levels ( code radix ) from 2 ( binary ) to 4 , the transmitted power will have to increase to maintain the 30dB SNR .

If amplitude shift keying is considered ( as will be discussed in section 4.4.1 ) , the new transmission levels will now be 0 , 1/3 , 2/3 , and 1 , rather than 0 and 1 . The difference in voltage levels is now 1/3 rather than 1 . The difference in power levels is 1/9 . Therefore transmitted power must be multiplied nine fold when the signalling speed is doubled .

A general expression may be written:

$$\frac{P_n}{P_2} \equiv (n - 1)^2$$

Where: n = number of levels in the code

$P_n$  = power required in 'n' level code

$P_2$  = power level required in binary code

Therefore the capacity of a noisy channel may be defined as :

$$\text{Channel capacity ( C )} \equiv \delta f \log_2 \left( 1 + \frac{S}{N} \right) \quad 4.2$$

Where  $\delta f$  = bandwidth ( Hz )

$S/N$  = signal to noise ratio over the bandwidth ' $\delta f$ ' .

It must be noted that an increase in bandwidth does not increase the channel capacity by a similar amount . This is because as bandwidth increases , the noise power also increases , thus limiting channel capacity .

### **4.1.3 Modulation**

So far the discussion of data transmission has been limited to the raw digital data , together with the encoding process , which together create the baseband signal spectra . The process of modulation is used to transpose the baseband signal to a frequency which will allow a more efficient transmission . With reference to fig 4.1 , modulation may be used to 'shift' a baseband mains signal to a frequency which avoids noise , low impedances caused by resonant loads , or even another PLC signal . These factors which necessitate the use of modulation were covered in chapter 3 . The following sections of this chapter will provide an insight into the common types of modulation , together with their respective advantages and disadvantages when used as a power line carrier . A more thorough approach is presented by Kennedy & Davis [67] and Taub & Schilling [68] . Following these discussions a survey of PLC modulation schemes in current use is presented .

## **4.2 Analogue Modulation Schemes**

An analogue modulation scheme may be defined as the use of an analogue carrier wave to convey the information contained in an analogue baseband signal . This may be accomplished with amplitude and angle modulation .

### **4.2.1 Amplitude Modulation ( AM )**

In Amplitude Modulation (AM) the amplitude of the carrier signal is varied by the modulating signal whose frequency is invariably lower than that of the carrier . To define AM , the amplitude of the carrier is made proportional to the instantaneous amplitude of the modulating signal . The process of amplitude modulation does not change the phase of the signals involved . Several variations of AM are in widespread use . The following

section introduces the most basic form of AM ( Double Sideband , full Carrier ) , followed by a description of its associated variants .

i) Double Sideband , Full Carrier ( DSBFC ) .

It may be shown that the amplitude modulated wave ( a baseband signal of bandwidth 'fm' ) contains three terms .

- i) The unmodulated carrier ( fc )
- ii) A lower sideband ( lsb ) at fc - fm
- iii) An upper sideband ( usb ) at fc + fm

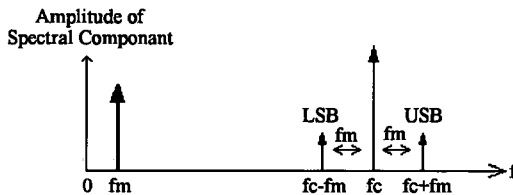

Fig 4.2: Frequency spectrum of DSBFC .

An important feature of this type of modulation is that the bandwidth required is twice the frequency of the modulating signal , in other words the bandwidth required is twice the highest modulating frequency . Also the amplitude of the carrier remains unchanged whereas sideband amplitude depends on the modulation index , and may never exceed half the amplitude of the carrier . An expression for bandwidth may be stated as:

$$\text{Bandwidth ( B )} = 2 * f_m$$

The total power in the modulated signal increases to its maximum of  $P_t = 1.5P_c$  (  $P_c$  = carrier power ) when the % modulation approaches 100% . The advantages in using the AM variant DSBFC are that it is easy to generate , receive and demodulate - this leads to simple and inexpensive receivers .



## ii) AM: Single Sideband Techniques

Although the use of DSBFC is widespread, due to the relative simplicity of the modulating and demodulating equipment, the carrier is superfluous as it carries no information and one of the sidebands is redundant as it is a mirror image of the other. These factors lead to DSBFC's inefficient usage of bandwidth and transmitter power. In contrast, Single Sideband techniques permit more efficient usage of bandwidth and transmitter power as only one of the signals sidebands is transmitted.

The following diagram illustrates the frequency spectrum of Single Sideband, Suppressed carrier (SSSC).

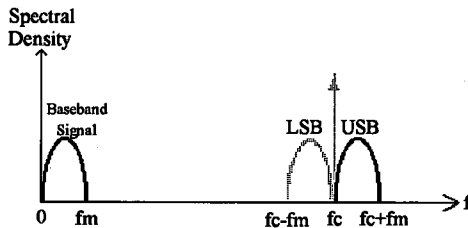

Fig 4.3: Frequency spectrum of SSSC.

With the lower sideband removed and the carrier suppressed, the single sideband, suppressed carrier signal occupies less bandwidth than its DSBFC counterpart.

In this case Bandwidth ( $B$ ) =  $f_m$

The process of removing the unwanted sideband may be accomplished by several methods, including the following:

- a) Filter system: Simply filter out the unwanted sideband, disadvantage: filter circuits will only adequately work up to a certain frequency.
- b) Phase shift method: By phase shifting the carrier and modulator, then modulating, the added signals will 'cancel out' one of the sidebands. This is possible at all frequencies.

iii) Additional AM variants .

**A3E: Double Sideband Full Carrier** : 'standard' AM e.g.- for broadcasting . Advantages: simplicity of transmitter and receiver .

**R3E: Single Sideband , reduced carrier** : An attenuated carrier is inserted into the SSB signal to facilitate receiver tuning and demodulation . This system is steadily being replaced by J3E . Advantages: less bandwidth required than A3E , but requires less complex demodulation circuits than J3E ( because of included carrier ) .

**H3E: Single Sideband , full carrier** : Used as a compatible AM broadcasting system with A3E receivers . Advantages: The inclusion of a full carrier permits reception on A3E receivers . Drawback: more transmitter power required because of full carrier .

**J3E: Single Sideband , Suppressed carrier** : Now the standard form of SSB for radio communications . Advantage: more efficient bandwidth utilisation and less transmitter power than A3E , R3E and H3E .

**B8E: Two independent sidebands , with a carrier most commonly attenuated or suppressed , also known as ISB** , used for HF point to point radiotelephony in which more than one channel is required . Advantage: Twice as much information may be transmitted on two independent sidebands .

**C3F: Vestigial Sideband ( used for television video transmissions )** : In this case the vestige i.e.- trace of the unwanted sideband is transmitted , usually with a full carrier , this is done to conserve bandwidth. The carrier is transmitted in order to simplify the receiver , in doing this a portion of the unwanted sideband is inevitably transmitted . Advantage: less complex filter techniques are required .

In conclusion , AM systems have limited PLC usage due to their inherent susceptibility to noise and signal attenuation at frequencies in close proximity to the carrier . Early PLC systems made use of AM mainly for voice and audio transmissions , where partial loss of the transmission did not mean a total loss in intelligibility . Such systems , described by Barstow [64] , became the forerunners of analogue PLC systems . More recent developments of AM PLC's has led to the use of multiple carrier AM modulation , reviewed by Nagaoka [65] . These systems rely on multiple carrier frequencies being 'spread' in order to avoid narrow band noise , attenuation , and 'troughs' in propagation .

#### **4.2.2 Angle Modulation**

Angle Modulation may split into two forms . That is Frequency Modulation ( FM ) and Phase Modulation ( PM ) .

Frequency Modulation is a system in which the amplitude of the modulated carrier is kept constant while its frequency and rate of change are varied by a modulating signal usually of lower frequency . The shift in the carrier frequency from its 'resting' point compared to the amplitude of the modulating signal is known as the 'deviation ratio' .

Phase Modulation uses the amplitude of a modulating signal to proportionally vary the phase of a carrier signal .

e.g. An unmodulated wave ( carrier ) may be represented by:

$$x = A \sin(\omega t + \Phi)$$

Where x = instantaneous value ( of current or voltage )

A = maximum amplitude

$\omega$  = angular velocity ( rads per second )

$\Phi$  = phase angle ( rads )

FM involves proportionally varying  $\omega$  by the amplitude of a lower frequency modulating signal.

PM involves proportionally varying  $\Phi$  by the amplitude of a lower frequency modulating signal.

FM may be considered a form of PM as changes in carrier frequency ( produced by a varying modulating signal ) will introduce phase changes in the carrier which are a function of the modulating signal . Similarly , the phase modulation of a carrier will modify the frequency of the carrier , thus PM may be considered a form of FM .

This leads to the term 'Angle Modulation' applying to both FM and PM and unless information of the modulating signal is available FM and PM may remain indistinguishable.

An important aspect associated with FM is the frequency deviation of the carrier signal . It may be defined as the maximum departure of the instantaneous frequency from the carrier frequency . It is related to the modulation index ( $\beta$  ) by the following equation.

$$\text{Modulation index} \equiv \frac{\text{Frequency deviation}}{\text{Modulating frequency}} \quad 4.3$$

Similarly in PM the phase deviation can be defined as the maximum departure of the total angle from the phase angle of the carrier .

The characteristics of FM may be summarised by the following points:

◆ Frequency Spectrum:

Without entering into the mathematics of Bessel functions , for a very small value of modulation index (  $\beta$  ) , typically much less than unity , an FM signal is composed of a carrier and a single pair of sidebands with frequencies  $f_c \pm f_m$ . This type of FM signal is

known as 'narrowband' FM . In referring to tables of Bessel functions it can be seen that as the modulation index ( $\beta$ ) is increased the amplitude of the first sideband pair also increases . Furthermore , the amplitude of a second sideband pair at  $f_c \pm 2f_m$  becomes significant . This effect continues as the modulation index ( $\beta$ ) increases thus producing 'wideband' FM . It may be noted that the distribution of sidebands is symmetrically centred around the carrier frequency . Also , if the modulation index is known , by referring to tables the number of sidebands present in the frequency spectrum may be determined .

An important factor which may be noted here is that unlike AM , in an FM signal the amplitude of the spectral component at the carrier frequency is not constant over differing values of  $\beta$  . As the power of an FM signal remains constant over different values of modulation index , the addition of further sidebands to the FM signal spectrum must be balanced by a reduction in carrier amplitude . Therefore as the modulation index ( $\beta$ ) increases , carrier amplitude decreases . At certain values of  $\beta$  the carrier can disappear altogether .

The effects of modulation index ( $\beta$ ) on frequency spectrum may be summarised as follows:

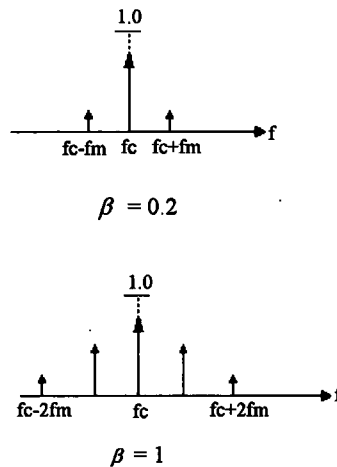

Fig 4.4: Effect of modulation index on frequency spectrum .

By referring to tables of Bessel functions it is possible to evaluate the size of the carrier and each sideband for each specific value of modulation index. It is then possible to plot the frequency spectrum of the FM wave. Equation 4.3 implies that as the 'depth' of the modulating signal is increased, so is the frequency deviation, therefore increasing the modulation index, hence increasing the required bandwidth. Alternatively, as the modulating frequency decreases the modulation index increases. This has the effect of increasing the number of sidebands but not necessarily the bandwidth.

Equation 4.3 also implies that in practice the bandwidth used is one that has been calculated to allow for all significant amplitudes of sideband components under the most exacting conditions. For example it must be ensured that with maximum deviation, by the lowest modulating frequency, no significant sidebands are 'lopped off'.

◆ **Bandwidth:**

The bandwidth of a sinusoidally modulated FM signal may be approximately stated by 'Carson's' rule.

$$\text{i.e. Bandwidth (B)} \approx 2 (\Delta f + f_m)$$

That is, the bandwidth is twice the sum of the maximum frequency deviation and the modulating frequency. It can be seen that as the modulation index increases so does the bandwidth.

Alternatively;

$$\text{Bandwidth} = f_m * (\text{freq. spread of most distant sideband from the carrier}) * 2$$

Where,  $f_m$  = modulating frequency

and, the frequency of the most distant, significant sideband from the carrier may be obtained from the modulation index and Bessel tables.

◆ **AM and FM Comparisons:**

Unlike AM and its variants, FM's frequency spectrum contains an infinite number of sidebands (of which a limited number are required for signal transmission / reception).

### FM : Advantages

- i) All the transmitted power in FM is useful whereas in AM most of it is transmitted in the carrier .
- ii) FM reception is more immune to noise than AM reception , because FM receivers may be fitted with amplitude limiters to remove amplitude variations caused by noise .
- iii) In FM it is possible to increase carrier deviation in order to reduce noise ( i.e. an increase in modulation index will increase signal to noise ratio ) , this is not possible in AM systems .

### FM : Disadvantages

- i) A much wider channel ( bandwidth ) is required by FM - up to ten times .
- ii) FM transmitting and receiving equipment tends to be more complex than that of AM .

## **4.3 Pulse Modulation Schemes**

Pulse Modulation may be used to transmit analogue information . Continuous waveforms may be sampled and transmitted with any required synchronising pulses ( unlike AM and FM where waveforms are continuously transmitted ) . At the receiver the original waveforms may be reconstructed .

Pulse modulation may be subdivided into analogue and digital . In analogue the indication of a sample amplitude may be infinitely variable whilst in a digital sample the amplitude is sampled to the nearest predetermined level .

Pulse Amplitude and Pulse Time modulation are both forms of analogue modulation whilst Pulse Code and Delta modulation systems are both digital .

### 4.3.1 Pulse Amplitude Modulation ( PAM )

PAM is a modulation system in which the signal is sampled at regular intervals , each sample is made proportional to the amplitude of the signal at the sampling instant .

e.g.:

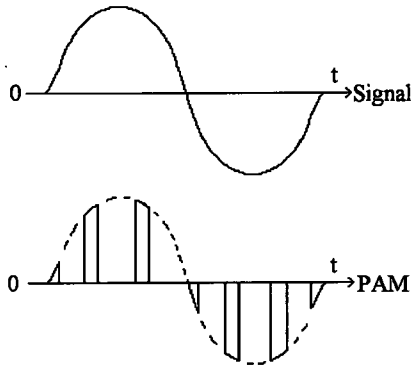

Fig 4.5: PAM waveform

The pulses may be sent by cable , or else used to frequency modulate a carrier ( this produces PAM-FM ) . Its major disadvantage is the inconsistent amplitude of pulses , it is therefore infrequently used . Its advantage lies in the fact that it is easy to generate and demodulate PAM .

### 4.3.2 Pulse Time Modulation ( PTM )

As in PAM , the signal is sampled , but the pulses which indicate instantaneous sample amplitudes themselves all have constant amplitude . In order to convey the signal information the pulses timing characteristics are varied , being made proportional to the sampled signal amplitude at that instant. It should be noted that all forms of PTM have the same advantage over PAM as FM has over AM , i.e.: the constant amplitude pulses of PTM give greater noise immunity .

Two forms of Pulse Time Modulation are Pulse Width modulation ( PWM ) and Pulse Position modulation ( PPM ) .



If PWM is firstly considered ;

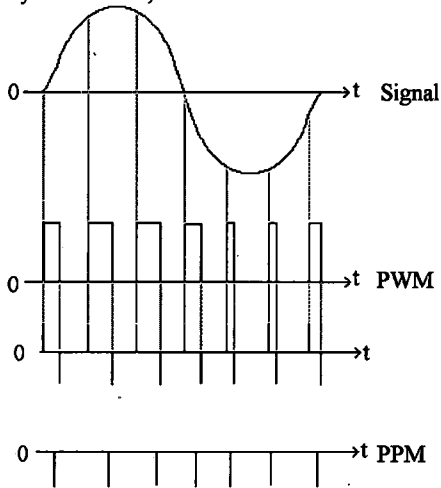

Fig 4.7: PPM waveform .

The position of the negative going edges of the PWM wave are a function of the original signal . Therefore in differentiating the PWM wave we obtain an 'edge' wave . Then by removing the positive edges a PPM signal is obtained . Here the position of the negative pulses relative to a synchronisation pulse is a representation of the original signal.

### 4.3.3 Pulse Code Modulation ( PCM )

PCM differs from the pulse modulations looked at so far in that PCM is a digital process . Instead of sending a pulse train capable of continuously varying a parameter , PCM produces a series of numbers or digits . Each digit represents an approximate amplitude of the signal amplitude at that instant .

For example a digital 'word' may be used to represent a certain voltage level of a signal at an instant in time. Because the digital words may be encoded , with the addition

of supervisory signals , PCM is highly immune to noise . Thus , amplitude modulation of PCM may be used ( PCM-AM ) .

#### **4.3.4 Comparisons of Pulse Modulation Systems**

The effects of noise may be reduced by using a constant amplitude modulation rather than AM . Thus PWM , PPM and PCM have all the advantages of FM when it comes to noise performance . It may also be shown that pulses with steeper sides have greater noise immunity . Unfortunately in transmitting 'steeper' pulses a greater bandwidth is required . In this case PWM and PPM share an FM characteristic of the ability to trade bandwidth for improved noise performance .

PCM offers much better noise immunity as sloping pulses are not affected by noise , as PCM only depends on the presence of absence of pulses at any given time . Studies have shown that PCM can be relayed without degradation when the SNR exceeds about 21dB .

The ability to relay signals without distortion and to use poor quality transmission paths is a very significant incentive to use digital rather than analogue modulation systems.

Unfortunately . PCM does have its disadvantages , namely ;

- i) PCM requires very complex encoding and quantizing circuitry .
- ii) PCM requires a large bandwidth compared to analogue systems . This is because usually more than one bit of information must be conveyed in order to represent one signal voltage level .

However , its advantages are:

Due to its noise immunity , PCM requires fewer repeaters on a communications channel compared with its counterparts . Also , due to advances in large scale integration the complexity of PCM is becoming less of a significant cost penalty .

PCM Variants:

In order to reduce the problem of excessive bandwidth required by PCM , Differential PCM evolved . DPCM involves representing the difference in amplitude between consecutive samples rather than the absolute value as in PCM . This system relies on the fact that in reality large variations from one sample to the next are unlikely . Thus , it takes fewer bits to represent this 'change' in amplitude rather than the absolute amplitude , and so a smaller bandwidth is required .

In reality , this form of PCM has not been widely accepted because of the complicated coding and decoding process outweighing any advantages gained .

Delta modulation is a form of DPCM . In simple Delta modulation just one bit per sample is used to indicate whether the signal is larger or smaller than the previous sample . This system has the advantage of very simple coding and decoding procedures . However Delta modulation cannot handle rapid amplitude changes , therefore quantisation noise remains high .

#### **4.4 Digital Modulation Systems**

The previous sections of 4.2 and 4.3 have described modulation schemes which are primarily concerned with the modulation and transmission of an analogue baseband signal . However , the baseband information associated with remote metering systems and

services will invariably be digital in nature . Thus the modulating signal will be digital and will therefore require digital modulation techniques .

#### 4.4.1 Amplitude Shift Keying ( ASK )

The resulting signal occupies a bandwidth centred on the carrier signal . The two binary values are represented by two different amplitudes of the carrier frequency , commonly one of the amplitudes is zero , this is known as 'On-Off' keying ( OOK ) . ASK is susceptible to sudden gain changes and is rather an inefficient technique . On- Off keying may be considered a form of binary ASK ( BASK ) . By using several amplitudes of carrier a multi level baseband code may be used . This results in more information being conveyed . Unfortunately this method is even more susceptible to noise .

In PLC systems attenuation troughs and single frequency interference can easily 'damage' the signal . This is probably the simplest type of powerline carrier and is probably responsible for PLC's bad reputation . Hence ASK PLC systems are relatively uncommon and are being superseded by FSK and spread spectrum systems [37] .

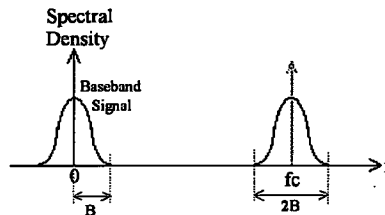

Fig 4.8: Spectrum of ASK .

The spectrum of ASK is simply the baseband signal spectrum 'shifted' up to centre around the carrier frequency ' $f_c$ ' . ( single sided spectrum shown ) .

Note: The frequency spectrum will remain the same when 'n-array' ASK is implemented .

$$\text{Bandwidth} \equiv 2 * \text{Baseband Bandwidth}$$

#### 4.4.2 Frequency Shift Keying (FSK)

Here the two binary values, of the baseband signal, are represented by two frequencies near the carrier frequency. FSK is a system of frequency modulation, with the carrier sited midway between the two 'mark' and 'space' frequencies. FSK is less susceptible to error than ASK.

If the two carrier frequencies are close together narrow band FSK results. Like ASK this powerline carrier method suffers from attenuation troughs that exist at or near the carrier frequencies. An advantage of narrowband FSK is its conservative use of bandwidth.

So far the use of two frequencies to represent two binary values has been considered. This is known as binary FSK (BFSK).

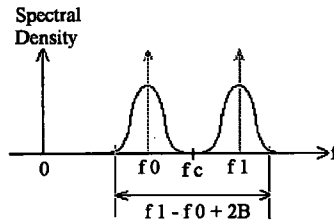

Fig 4.9: Spectrum of binary FSK.

The bandwidth occupied is the separation between the two signalling frequencies plus the two sidebands, giving  $f_1 - f_0 + 2B$  where  $B$  is the highest frequency in the baseband signal. The low complexity and superior performance over ASK systems has led to the widespread adaptation of FSK as a PLC modulation technique. Results from a literature survey, illustrated in table 4.1, reveal FSK as the most prevalent modulation scheme used on MV power networks. The use of FSK on LV power distribution networks is also widespread, but the more hostile LV environment has favoured the

development and adaptation of spread spectrum modulation systems . A detailed study of spread spectrum techniques is presented in section 4.5 of this chapter .

| Network      | Carrier Freq                          | Data Rate     | Output Power     | Reference |
|--------------|---------------------------------------|---------------|------------------|-----------|
| LV           | 50kHz                                 | 300 Baud      | 0.01-0.5 Watt    | [44]      |
| Home Systems | 132.5kHz<br>± 600 Hz                  | 1200 bps      | < 116 dB $\mu$ v | [53]      |
| Home Systems | 132 kHz                               | 1000 bps      | *****            | [35]      |
| LV           | 100k / 130kHz                         | 300 / 600 bps | 5v / 2.5v p/p    | [20]      |
| LV           | 7k - 10kHz                            | 100 bps       | *****            | [55]      |
| LV           | 82 kHz                                | 600 bps       | 1 Watt           | [39]      |
| MV           | Multiple Carrier ,<br>250kHz - 750kHz | *****         | *****            | [9]       |
| MV           | Dual Carrier<br>8kHz - 11kHz          | 4 Baud        | *****            | [55]      |
| MV           | 60k / 100kHz                          | 600/1200 Baud | 2.5v - 15v pp    | [20]      |
| MV           | 70kHz                                 | 2400 bps      | 0.5 Watt         | [8]       |
| MV           | 6kHz-12kHz                            | 25 baud       | *****            | [56]      |
| MV           | 7kHz-10kHz                            | 500 bps       | *****            | [55]      |
| MV           | 72 kHz                                | 1200 bps      | *****            | [39]      |

Table 4.1: FSK Modulation Schemes .

Alternatively wideband FSK provides a more robust system . If only one of the carrier frequencies reaches the receiver the other still has ASK impressed on it . Wideband FSK , alternatively known as ' Spread Frequency Shift Keying ' ( S-FSK ) may be considered as a compromise between narrowband systems ( ASK , FSK ) and complex , expensive spread spectrum systems . The use of S-FSK systems [70] is gaining popularity due to its superior noise immunity over narrowband , coupled with its inexpensive

implementation [69] . Although wideband FSK offers this greater noise immunity it requires a greater bandwidth .

### **n-array FSK**

As in the cases of n-array ASK a multi level baseband code may be used to modulate several carrier frequencies to produce n-array FSK . This gives us an extension from binary FSK .

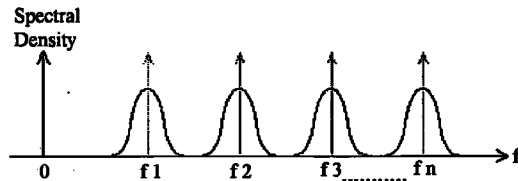

Fig 4.10: Spectrum of n-array FSK .

As can be seen from the frequency spectrum , the bandwidth of n-array FSK is dependant upon the number of signalling frequencies . Although more information is conveyed , the bandwidth is greater . An alternative approach to n-array FSK is to send the same information at each carrier frequency . Although resulting in redundancy a certain degree of frequency spreading is achieved . Such systems [55] gain an even greater immunity to noise , network attenuation and 'troughs' in propagation .

### **4.4.3 Phase Shift Keying ( PSK )**

In PSK the phase of the carrier is shifted to represent data . The following illustrate various ways of implementing PSK.

#### **i) Binary Phase Shift Keying:**

The simplest form of PSK is that of binary phase shift keying ( BPSK ) . In this variant of PSK the two states of the digital baseband signal create two discrete phase states in the carrier wave , for example  $0^\circ$  and  $180^\circ$  .

## ii) Differential Phase Shift Keying:

Here a binary '0' is represented by sending a signal burst of the same phase as the previous signal burst sent . A binary 1 is represented by sending a signal burst of opposite phase to the preceding one . Hence the phase shift is with reference to the previous bit transmitted rather than to some constant reference signal .

## iii) Quadrature Phase Shift Keying:

This is more efficient use of bandwidth than DPSK by using each signalling element to represent more than one bit . For example instead of phase shifts of 180 degrees , as allowed in PSK , QPSK uses phase shift multiples of 90 degrees (  $45^\circ$  ,  $135^\circ$  ,  $225^\circ$  ,  $315^\circ$  ) . This technique may be extended further by transmitting bits three at a time using eight different phase angles. This method may be looked upon as being a way of implementing 'n-array' coding . That is a multi level baseband code modulates a carrier producing multiple phase changes in the carrier . This is similar to n-array FSK but without paying the penalty of increased bandwidth .

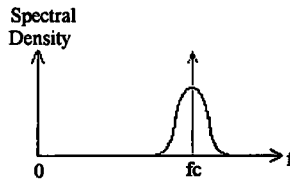

Fig 4.11: Spectrum of PSK .

Like ASK the spectrum of binary PSK is the baseband 'shifted' up to centre around the carrier ( note the absence of the carrier component ) . In QPSK and 'n-array' PSK the spectrum will remain the same as binary PSK . The use of PSK modulation as a PLC , [71],[54] , tends to suffer from similar problems as ASK in its susceptibility to single frequency interference and propagation troughs sited at the carrier frequency . With its added complexity over ASK and FSK its use has been limited in PLC applications , apart from baseband modulation in spread spectrum systems .



#### iv) Quadrature Amplitude Modulation ( QAM ) .

This type of modulation may be considered as a combination of n-array ASK and n-array PSK . In this case a multiple level baseband code may be conveyed by a number of discrete phase states and amplitudes of a carrier wave . An example of QAM is the modulation used in standard 9600 bps modems where twelve phase angles , four of which have two amplitudes are used .

#### **4.4.4 Comparisons of Digital Modulation Systems**

Without prior knowledge of the specific intended application of the modulation schemes just described , it only remains possible to make some general comparisons of their advantages and disadvantages .

In considering ASK , FSK and PSK , together with their variants , FSK will always require a greater bandwidth due to the multiple frequencies required in its transmission . The bandwidth of FSK increases further with the use of wide band FSK and n-array FSK , whereas the use of n-array ASK and n-array PSK require no more bandwidth than their binary counterparts . This is because the use of n-array ASK and n-array PSK permit more signalling states and therefore allow more information ( data ) to be conveyed per symbol . This does not modify the bandwidth requirements as bandwidth depends only upon the signalling rate and not the number of signalling states used . With these facts in mind it would appear that FSK provides the most inefficient usage of bandwidth for a given information rate . This conclusion also implies that for a fixed available bandwidth the variants of ASK and PSK can provide a greater information rate than FSK and n-array FSK .

In using multiple signalling states sited at the same carrier frequency ( as in n-array ASK and n-array PSK ) the need to separate the signalling states in order to reduce error rates , in the presence of noise , leads to a corresponding increase in mean signal power . In other words the 'price' paid for an increased information rate at constant bandwidth , is

an increase in transmitter output power . However , in n-array FSK , an information rate increase may be achieved with constant power , but at the expense of bandwidth .

The characteristic of a greater bandwidth requirement in wideband and n-array FSK may well be used to an advantage in some cases , particularly in very noisy environments and on networks with unpredictable propagation characteristics . In such conditions wideband and n-array FSK may be used to 'spread' the transmission of information over a large bandwidth . This will decrease the transmissions susceptibility to single frequency 'noise bursts' and 'troughs' in the propagation characteristics which would otherwise obliterate single frequency carriers such as ASK , PSK and their variants .

The use of such wide band modulation techniques may be extended by considering the use of 'Spread Spectrum' modulation schemes .

#### **4.5 Spread Spectrum Modulation**

The forthcoming section of this chapter is concerned with the recent widespread emergence of spread spectrum modulation systems . Prior to 1985 very few spread spectrum systems had ever been used outside the military bands . However in 1985 the Federal Communications Commission ( FCC ) permitted the use of spread spectrum signals in the Industrial , Scientific and Medical ( ISM ) bands . This has led to the widespread adaptation of spread spectrum as a PLC .

Although only a brief introduction into the variants of spread spectrum will be provided , a more rigorous study is covered by R.C.Dixon [72] , G.R.Cooper and C.D.McGillem [73] , together with their implementation as a PLC [74] . In addition to outlining the characteristics of spread spectrum modulation a literature review is presented which covers the main aspects of current spread spectrum systems .

### 4.5.1 General Characteristics

A spread spectrum system may be defined as one which the transmitted signal is spread over a wide frequency band , much wider than the minimum bandwidth required to transmit the information being sent . The transmitted bandwidth must be determined by some function that is independent of the message . This may be accomplished by modulating with the baseband information , a wideband encoding signal . The use of a wideband encoding signal is the characteristic of spread spectrum which distinguishes it from wideband FM and FSK . Although spread spectrum increases the redundancy of the transmission , the increase in bandwidth provides a corresponding increase in interference rejection .

### 4.5.2 Interference Rejection

With references to equation 4.2 of section 4.1.2 , and changing logarithmic bases , equation 4.2 becomes:

$$C = \delta f 1.44 \log_e \left( 1 + \frac{S}{N} \right)$$

Now for a small  $\frac{S}{N}$  ( $\leq 0.1$ ) , as would be desirable ,

$$C \approx \delta f 1.44 \frac{S}{N}$$

Since applying logarithmic expansion;

$$\log_e \left( 1 + \frac{S}{N} \right) \equiv \frac{S}{N} - \frac{1}{2} \left( \frac{S}{N} \right)^2 + \frac{1}{3} \left( \frac{S}{N} \right)^3 - \frac{1}{4} \left( \frac{S}{N} \right)^4 \dots \dots \dots \left( -1 < \frac{S}{N} < 1 \right)$$

Therefore if 'C' is the desired information rate;

$$\delta f \equiv \frac{N \cdot C}{S \cdot 1.44} \quad 4.4$$

Equation 4.4 illustrates the fundamental property of spread spectrum systems , that is , under a given signal to noise ratio the information error rate may be reduced by increasing the bandwidth .

Furthermore , the ability of spread spectrum modulation to increase the bandwidth of the transmitted signal leads to an increase in 'process gain' . For modulation systems in general , the process gain is termed the difference in output and input signal to noise ratios obtained in the modulation process . The process gain of a spread spectrum system may broadly be defined by the ratio of transmitted bandwidth to the baseband data information rate .

i.e.:

$$\text{Process Gain} \equiv \frac{\text{Bandwidth of transmitted signal}}{\text{Information rate}} \equiv \frac{BW_{tx}}{R_{info}} \quad 4.5$$

The process gain of a spread spectrum system is an important parameter , as it expresses the ability of the system to function in the presence of interference .

### **4.5.3 Spread Spectrum Variants**

Spread spectrum modulation techniques may be categorised into the following groups .

- i) Direct Sequence: This variant uses modulation of a carrier by a digital code sequence whose frequency ( chip rate ) is much higher than the information signal bandwidth .
- ii) Frequency Hopping: The carrier frequency is shifted in discrete increments in a pattern dictated by a code sequence .

iii) Chirp Systems: Here the carrier is swept over a wide frequency band during a given pulse interval .

The differing techniques of implementing spread spectrum modulation give rise to their relative merits and disadvantages . These , together with their theory of operation , will now be discussed .

**4.5.4 Direct Sequence Spread Spectrum**

The implementation of direct sequence spread spectrum ( DS-SS ) is illustrated in fig 4.12 .

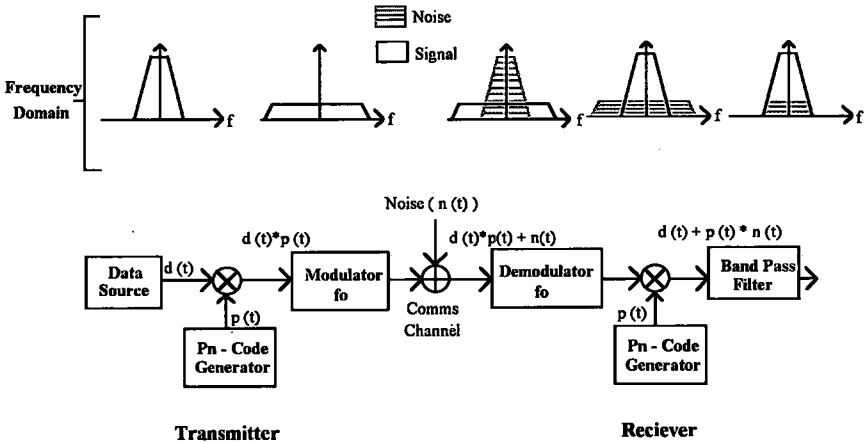

Fig 4.12: Direct Sequence Spread Spectrum .

In DS-SS transmission the baseband data source ( in digital form [d(t)] ) is used to multiply ( modulate ) a pseudonoise code sequence ( p(t) ) . This has the effect of spreading the signal over a bandwidth equal to 2\*( clock chip rate ) . The spread spectra may then be 'shifted' to a given frequency by the modulator 'fo' . Upon transmission the signal may be subjected to noise ( n(t) ) , shown in the frequency domain illustration . On reception , after demodulation , the signal is multiplied by a reference pseudonoise

generator , which possesses the same code sequence ( in synchronisation ) as that of the transmitter .

Any incoming signal which is not synchronous with the receivers pseudonoise sequence ( e.g. noise and unwanted signals ) will not correlate with it and will be 'spread' to its own bandwidth plus the bandwidth of the pseudonoise sequence . On the other hand the data source , which is embedded in the pseudonoise sequence , will correlate with the receivers pseudonoise sequence and may thus be 'reconstructed' . The code used in the pseudonoise generators must have the properties of good autocorrelation ( for the purposes of 'decoding' at the receiver ) and low cross correlation ( for good noise and interference suppression properties ) . The bandpass filter is then able to reject the unwanted signals .

#### 4.5.5 Frequency Hopping Spread Spectrum

The frequency hopping variant of spread spectrum ( FH-SS ) may be thought of as an extension of n-array FSK , but using far more frequency channels , each one being selected by a code sequence . Its method of implementation is as illustrated in fig 4.13 .

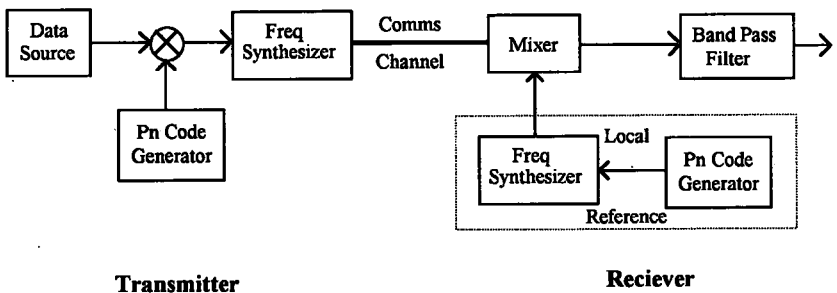

Fig 4.13: Frequency Hopping Spread Spectrum .

As in the direct sequence system the baseband data source modulates the pseudonoise code sequence . The frequency synthesiser responds to the modulated code

sequence by producing a series of discrete spectral lines amongst which the carrier will 'hop' at a rate equal to the code generator clock rate as shown in fig 4.14 . The choice and pattern of frequency hops is determined by the code sequence .

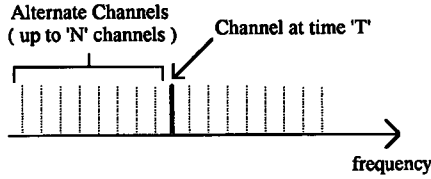

Fig 4.14: Spectra of Frequency Hopping Spread Spectrum .

Upon reception the system receiver employs a pseudonoise generator as a 'local reference' which provides the same sequence as the one in the transmitter . As in the case of direct sequence systems , any signal which is not a replica of the local reference is spread by multiplication in the mixing section . The desired signal then correlates with the local reference which may then be filtered prior to demodulation .

Frequency hopping systems cope well with wideband noise because the information is spread over a wide bandwidth . On the contrary , narrow band interference may well lead to information loss if one code chip per information bit is used to convey the message . This is obviously undesirable and may be remedied by the introduction of redundancy . Here , several chips ( frequencies ) may be used to transmit one bit of information , thus reducing error rate . The price paid for introducing redundancy is an increase in frequency hop rate and required bandwidth .

#### **4.5.6 Chirp Spread Spectrum**

In Chirp systems the RF frequency varies ,  $\Delta f$  , in some known way in each pulse period ,  $\Delta t$  , ( fig 4.15 ) . The receiver used in chirp systems is a matched filter , matched to the angular rate of change of the frequency swept signal .

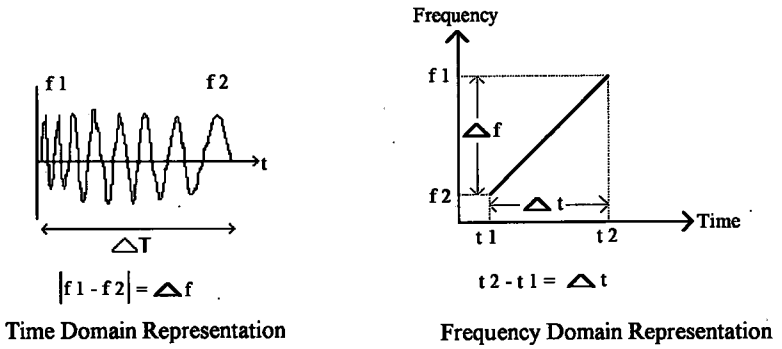

Fig 4.15: Chirp Spread Spectrum .

At the receiver the signal is stored until the entire ensemble of frequencies in one sweep arrives . The receiver then sorts the signals so that they add together within a much shorter time period , reinforcing one another to produce a much stronger signal .

#### 4.5.7 Hybrid Systems

The different variants of spread spectrum may be combined in order to obtain a system which possesses the merits of each of the techniques . For example , Frequency Hopped Direct Sequence ( FH-DS ) . This hybrid system consists of a direct sequence modulated signal whose centre frequency hops periodically .

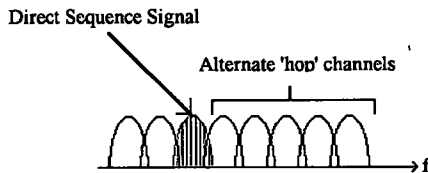

Fig 4.16: Frequency Spectrum of FH-DS .

Fig 4.16 illustrates the spectra of FH-DS , which may be considered as direct sequence spread spectrum superimposed on frequency hopping spread spectrum .



#### **4.5.8 Relative Merits of Spread Spectrum Systems**

In their application as PLC's , the spread spectrum techniques discussed in the previous sections posses their associated advantages and disadvantages over other modulation techniques . These may be highlighted by the following points .

##### **Merits:**

- ◆ **Selective Addressing / Code Division Multiplexing:** Spread spectrum receivers may be configured to only receive transmissions which contain a certain spectrum spreading code [76] . Transmissions destined for other receivers will be seen as noise . This forms the basis of code division multiplexing .
- ◆ **Low Signal Power / Security:** Due to the correlation properties of the spectrum spreading code the signal power may be many times lower than background noise ( a distinct advantage in PLC's ) . This , together with the unique nature of the spectrum spreading code makes interception by unintended receivers virtually impossible .
- ◆ **Greater Process Gain:** The increased bandwidth nature of spread spectrum gives rise to much higher levels of process gain than is possible in more 'conventional' modulation techniques .

Amongst spread spectrums' drawbacks are;

- ◆ **Expensive Systems:** Due to the added complexity of spread spectrum techniques , such systems are more costly to implement than narrowband systems . Although , with the ever decreasing cost of VLSI technology the use of direct sequence systems is becoming more widespread . However the necessity of fast response frequency synthesisers and matched filters , in frequency hopping and chirp systems respectively , leads these systems to be a more expensive option .
- ◆ **Synchronisation:** Because the code generators in the transmitter and receiver must remain in synchronisation , any loss in synchronisation due to channel propagation and phase characteristics , will lead to an interruption in transmission . To counteract the

synchronisation problem sliding correlators and 'tau dither' techniques may be employed , but these will obviously add complexity and hence cost to the system .

◆ **Bandwidth:** The very nature of spread spectrum systems leads to the less conservative use of frequency spectra . In the restricted bands allocated to power line signalling this may well prove to be a hindrance .

To summarise , the use of spread spectrum as a PLC modulation technique is gaining widespread acceptance by PLC system developers . Table 4.2 provides a summary of current systems on the market . Although this may only represent a portion of the market it may be deemed representative of the market share which the spread spectrum variants occupy . The predominance of direct sequence systems is apparent , largely due to their more inexpensive implementation costs .

| <b>Network</b> | <b>S/S Variant</b>        | <b>Bandwidth</b> | <b>Data Rate</b>      | <b>Reference</b> |
|----------------|---------------------------|------------------|-----------------------|------------------|
| LV             | Direct Seq                | *****            | 516 Baud              | [44]             |
| LV             | CHIRP                     | 95kHz-105kHz     | *****                 | [46]             |
| In building LV | Direct Seq                | 52kHz-156kHz     | 395 bps               | [47]             |
| Home Systems   | CHIRP                     | 100k-400kHz      | 10 kbps               | [48]             |
| LV and MV      | Freq Hopping              | 20kHz-90kHz      | 1000 bps              | [17]             |
| Home Systems   | Direct Seq                | 10kHz-450kHz     | 9.6 kbps              | [49]             |
| Home Systems   | CHIRP                     | 20kHz-80kHz      | 2 kbps                | [50]             |
| LV             | Direct Seq                | 100k-450kHz      | 10 kbps               | [51]             |
| LV             | Direct Seq                | 9kHz-90kHz       | 2 kbps                | [51]             |
| LV             | Narrow band<br>Direct Seq | 125k-150kHz      | *****                 | [51]             |
| LV             | Direct Seq                | 40kHz-90kHz      | 200 bps               | [40]             |
| LV             | Adaptive Freq<br>Hopping  | 9kHz-95kHz       | 400 bps -<br>3200 bps | [52]             |

Table 4.2: Spread Spectrum Modulation Systems

## **4.6 Ultra Narrowband**

With the advent of spread spectrum PLC systems , a technology which seems to have been either overlooked or dismissed as being unsuitable for today's data rate requirements , is that of 'ultra narrowband' modulation . These modulation schemes employ modulation techniques which limit the signals bandwidth to less than 1Hz . On this basis it would seem that this restricted bandwidth is incapable of supporting any usable data rate , but systems such as the 'Turtle' system [38] have made use of ultra narrow bandwidth techniques . The principles of ultra narrowband as a PLC is outlined in the next section .

### **4.6.1 Ultra Narrowband as a PLC**

When used as a PLC , an ultra narrowband signal is quite often sited at frequencies below 1kHz . This permits the carrier to be 'placed' between the mains frequency harmonics , thus avoiding interference . With bandwidths of a fraction of a Hertz the following benefits are realised .

- ◆ **Greater Noise Immunity:** Over a small bandwidth the noise spectral density will be much less ( fig 4.17 ) . Therefore a transmitter operating with a similar output power to a wideband or narrowband transmitter will have a superior signal to noise ratio .
- ◆ **Frequency Multiplexing:** The use of ultranarrow channels means that each unit ( meter ) in a PLC system may be allocated its own frequency channel . Because of each channels ultranarrow bandwidth , several hundred units will only occupy a relatively small frequency band . With each unit able to constantly transmit on its own channel the effects of low data rates may be compensated for .
- ◆ **Signal Propagation:** Because the mains distribution network is designed for efficient propagation at 50Hz , carriers sited at these lower frequencies will have better propagation characteristics . In fact , ultranarrow bandwidth signals sited at or near the mains frequency will suffer little attenuation when passed through distribution

transformers and capacitor banks . The much longer wavelength associated with these lower carrier frequencies results in even the longest LV and MV feeders appearing electrically long , thus minimising losses due to standing wave phenomena .

◆ Cheaper Systems: The lower complexity of ultra narrowband systems reduces the production and installation costs . Hence PLC systems using these techniques may be implemented at lower cost than their narrowband and wideband counterparts .

The price to be paid for these system benefits is of course very low data rates . Frequency multiplexing does provide a degree of compensation , but even so , the data rates which may be achieved by ultra narrowband systems do not approach those obtained from narrowband or wideband systems .

If ultra narrowband is to be seriously considered as a PLC , a trade-off between its relatively low implementation costs , together with good propagation characteristics and its low data rates ( which mean a restricted service ) must be examined .

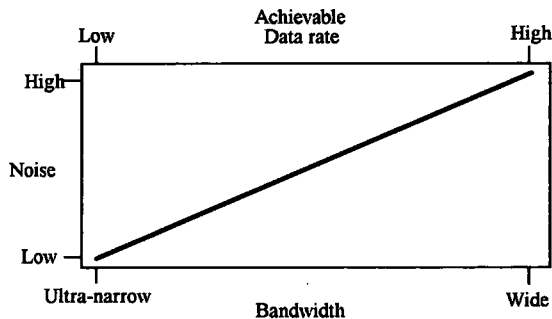

Fig 4.17: Trade-offs of different techniques .

Fig 4.17 graphically illustrates the trade-offs between ultra narrow , narrow and wide bandwidths , which must be considered in the PLC environment . Section 4.8 of this chapter will discuss these economic factors in addition to those governing the use of wideband systems and more conventional signalling techniques . But firstly , no discussion

of PLC signalling would be complete without a brief mention of some additional low frequency ( $< 10\text{kHz}$ ) systems .

## **4.7 Low Frequency Techniques**

These techniques , which are now well established , may be split into bi-directional and uni-directional systems .

### **4.7.1 Uni-directional Systems**

With reference to chapter 1 , section 1.4.4 , the use of cyclocontrol and ripple systems at frequencies of 50Hz and 750Hz respectively , is a well established widespread technique . Their low frequency , high transmitter power nature ensures good propagation and noise immunity . Although they possess the ability to propagate through distribution transformers their low data rate , high power , simplex transmissions , limit their application to load control and network switching operations .

More conventional FSK and PSK modulation techniques , [55][54] , may be employed in the lower frequency band ( $< 15\text{kHz}$ ) which take advantage of the networks favourable propagation characteristics at these frequencies . Unfortunately , as in the case of cyclocontrol and ripple systems , they too suffer from only being able to sustain relatively low data rates .

### **4.7.1 Bi directional Systems**

Perhaps the most widespread used system of this nature is that of the ' Two Way Automatic Communication System ' known as 'TWACS' [78] . In this proprietary technique two way communications from the distribution substation to transponders sited on the consumers premises is performed in a manner similar to that of cyclocontrol .

TWACS signals are generated by drawing precisely controlled current pulses from the 50Hz power wave at approximately 25 to 35 electrical degrees before the zero crossing and ending at the zero crossing [79]. Communication is in a half duplex fashion with an outbound data rate of 30 bits per second and inbound rate of 15 bits per second. The overall rate of inbound communication may be enhanced by operating six independent channels simultaneously.

Because TWACS operates at the 50Hz power frequency it has good propagation characteristics and is unhindered by transformers, capacitor banks, differing cables and varying loads. The low frequency nature eliminates any standing wave phenomena and permits propagation over long rural feeders ( up to 100km ). Unfortunately, as in the case of most low frequency systems, TWACS is plagued by high transmitter power consumption and low data rates.

Amongst other systems providing low frequency two way communications are variations in the cyclocontrol approach. They rely on modulating the 50Hz wave in close proximity to its zero crossings. Although two way communications are possible, the receivers are 'dumb' in the sense that they can only respond with 'yes' or 'no' answers. These systems [80][81] are only able to provide limited services due to their simplistic nature.

#### **4.8 PLC Modulation: The Trade-offs**

Having discussed and reviewed the modulation techniques employed in the realms of PLC modulation, the trade-offs which must be considered when choosing the most appropriate scheme for a given application may now be discussed. The factors influencing the choice of modulation scheme may broadly be defined as; the degree of service required versus the implementation and maintenance cost. In addition to this factor the choice of modulation must ensure reliable and robust transmission of data:

#### **4.8.1 Degree of Service**

In referring to the data rates required to perform the minimum service of meter reading , tariff download and load control , which were calculated in chapter 2 sections 2.5 and 2.6 , a comparison may now be made with data rates achieved by systems studied in this chapter . If the FSK and spread spectrum systems , listed in tables 4.1 and 4.2 respectively , are considered it would appear that these systems are capable of data rates in excess of those required to sustain a system which provides the 'minimum services' described in chapter 2 . However , such a minimum service system may be adequate for todays needs , but future needs may well call for the provision of additional services . If a metering system is to be acceptable to the consumer a certain degree of 'upward compatibility' should be designed into the system . This may be accomplished by adopting a system whose data rates will support additional future services . The systems listed in tables 4.1 and 4.2 certainly provide a margin of 'headroom' regarding data rate , however other factors must be borne in mind when considering a PLC system and its intended application .

#### **4.8.2 System Robustness**

When considering modulation schemes for PLC's the ability of a system to function reliably in the harsh environment of the mains network is a prime requirement . It would seem that from the modulation schemes studied in this chapter , spread spectrum systems provide the most robust system for data transmissions . Spread spectrum has now become a tried and tested widely accepted technology ; which performs reliably on different types of network during times of heavy loading . Unfortunately its prevalent use in PLC systems may well have been at the expense of overlooking less complex systems which are equally as robust . The ultra narrowband and low frequency systems of sections 4.6 and 4.7 provide a simple yet reliable means of power line carrier communication , but at the expense of a lower data rate .

### **4.8.3 System Architecture**

Another factor which must be examined when considering PLC modulation schemes is the architecture of the communication network . As far as PLC systems are concerned four possible architectures exist , namely LV network , MV network , LV / MV with transformer bypassed and LV / MV through transformer signalling . These may be considered in turn .

◆ **LV Network:** Of the two networks studied in chapter 3 the LV network provides the most hostile signalling environment . This has led to the predominant use of spread spectrum and FSK systems . Of these two systems the former provides the most robust system whilst the latter's conservative use of bandwidth , coupled with low complexity and modest robustness , make it an attractive system .

◆ **MV Network:** With more favourable propagation characteristics , communication on the MV network is sustainable with more 'conventional' narrowband PLC modulation techniques . The results of a literature review reveal an absence of wideband systems used solely for MV communication , with a corresponding predominance of FSK and PSK systems .

◆ **LV / MV , Transformer Bypassed:** With reference to section 1.5 , chapter 1 , fig 1.12 illustrates an LV / MV communication system which bypasses the transformer . In the systems studied in the current chapter a tendency towards using FSK and spread spectrum for this particular architecture is dominant [20][17] .

◆ **LV / MV , Through Transformer Signalling:** This network architecture calls for a particularly robust signalling technique if signals are to propagate through the distribution transformer . Ultra narrowband [38] and ripple systems [77] have through transformer capability but suffer from very low data rates and simplex transmission respectively . Power wave distortion techniques [62] also provide through transformer signalling but



require high power transmitters , thus restricting their use to one way transmission . More promising schemes which will propagate through the transformer are low frequency FSK systems [54] which provide bi directional transmissions with 'usable' data rates .

This particular architecture places yet another obstacle in the path of the PLC signal . Before the performance of narrowband and wideband systems may be assessed , regarding their through transformer signalling properties , a thorough investigation into the propagation characteristics of the distribution transformer must be conducted . This topic provides the nucleus of this particular research project .

#### **4.8.4 System Economics**

One of the most important factors governing the choice of PLC system is that of its cost of implementation . It is possible to devise a system which will operate reliably , at a high data rate , at any time of day , on both MV and LV networks . Unfortunately the price paid for this approach is system complexity and high cost . Spread spectrum systems are designed using this philosophy and are consequently more expensive than narrow band systems . However , the mass production of such systems may well reduce the unit cost to a point where total adoption of wideband systems will take place .

On the contrary , narrow band and low frequency techniques are well established and inexpensive to implement and maintain . If these proprietary systems are widely adopted by REC's and consumers , the use of spread spectrum may be restricted to expensive 'one off' systems . In the meantime the progressive reduction in VLSI production costs , used extensively in spread spectrum systems , tends to favour the future use of spread spectrum technology .

## 4.9 Summary

This chapter began by highlighting the need to modulate a baseband signal in order to facilitate propagation on mains distribution networks . Sections 4.2 , 4.3 and 4.4 described the more 'classical' , established modulation schemes in terms of frequency spectra , together with their relative merits and drawbacks when used in PLC systems .

In section 4.5 spread spectrum modulation was introduced , and its growing use in PLC systems was emphasised . As with the previous modulation schemes , the advantages and disadvantages of using spread spectrum as a PLC were covered . The following sections ( 4.6 and 4.7 ) provided an 'alternative' , less complex means of providing power line carrier transmissions . The final section of this chapter discussed the trade-offs which must be considered when adopting a modulation scheme as a PLC .

Throughout this chapter the results of a literature survey on current PLC systems has been constantly referenced in order to relate the theories of modulation to 'real life' applications . A summary of this survey is presented in fig 4.18 ( a & b ) in the form of a pie chart which reflects the market preference of modulation scheme . The illustration reinforces the comments made in section 4.8 regarding the widespread use of spread spectrum and FSK systems .

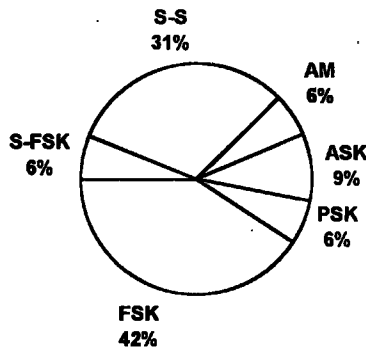
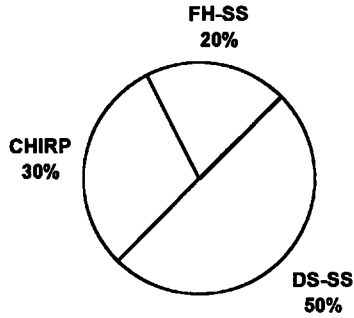

Fig 4.18a: Market Preference of Modulation Schemes .



**Fig 4.18b: Market Preference of Spread Spectrum Variants .**

Having derived the data rates required in order to provide a 'minimum service' system in chapter 2 , and covered the modulation schemes used in PLC systems in the current chapter , the propagation characteristics of the distribution transformer may now be examined . The following chapter ( chapter 5 ) will describe the methodical experimental approach used to determine the through signalling properties of the distribution transformer . With an MV / LV communication architecture in mind the 'through transformer' data rates may be established from these experimental results . The degree of service which may be provided using the most appropriate modulation technique will then be ascertainable .

# **Chapter 5 Experimental Work**

## **5.1 Introduction**

The work undertaken in this current chapter covers the experimental procedure , together with the results and findings , obtained from the experimental investigations which the research project focused on . The experimental work was performed at either one of two locations . Tests involving transformers powered up to their operational voltage were carried out in the test facility located at GEC Alstom , Stafford . Whilst a portion of the unenergised tests were performed at GEC Alstom the majority of unenergised work , together with preliminary investigations , was undertaken at John Moores University , Liverpool . The following account summarises the chronological approach made to the experimental programme .

### **◆ Preliminary Investigations One:**

Location; Laboratory , John Moores University , Liverpool .

Objective; To determine any relationship between the frequency response of differing signalling modes and configurations ( 50kVA transformer ) .

### **◆ Preliminary Investigations Two:**

Location; Test facility , GEC Alstom , Stafford .

Objective; Investigate the possibilities if signal coupling to 11kV .

### **◆ 11kV and 415V Coupling:**

Location; Laboratory , John Moores University , Liverpool .

Objective; Design and construct coupling circuits to facilitate connection of test equipment to 415V and 11kV .

◆ Experimental Work One:

Location; Test facility , GEC Alsthom , Stafford .

Objective; Obtain frequency response characteristics of a cross section of transformers ( Unenergised and isolated ) .

◆ Experimental Work Two:

Location; Test facility , GEC Alsthom , Stafford .

Objective; Obtain frequency response characteristics of a cross section of transformers in their energised ( powered up ) state .

◆ Experimental Work Three:

Location; Laboratory , John Moores University , Liverpool and GEC Alsthom , Stafford .

Objective; Investigate the ability of a commercially available Chirp spread spectrum system to propagate through transformers ( Energised and Unenergised).

In addition to the practical experimental programme the theoretical operation of modulation systems is used , in conjunction with experimental results , to asses the performance of through transformer signalling .

## **5.2 Transformer Signalling Modes and Configurations**

The following section describes the different signalling modes and configurations involved in through transformer signalling . An experimental investigation , together with its findings , is then described which determines the relationship between different signalling configurations within a mode of propagation .

Associated with each transformer are several combinations of signalling mode and configuration, each of which must be studied in the transformers unenergised and energised state. The variations of signalling mode and configuration are reviewed as follows.

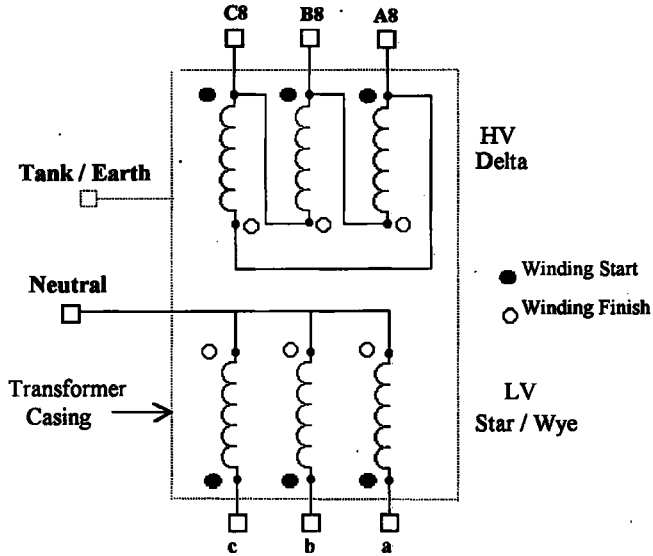

Fig 5.2.1: Dyn11 transformer terminals.

With reference to fig 5.2.1 the following modes of signal propagation exist.

a) Phase / Tank to Phase / Tank mode:

In this particular mode several configurations of terminal connections between transformer phase and tank are possible, namely,

|          | HV to LV Propagation  |          | LV to HV Propagation  |
|----------|---|----------|---|
| Group i) | A8 / Tank to a / Tank<br>A8 / Tank to b / Tank<br>A8 / Tank to c / Tank | Group i) | a / Tank to A8 / Tank<br>a / Tank to B8 / Tank<br>a / Tank to C8 / Tank |

Group ii) B8 / Tank to a / Tank  
 B8 / Tank to b / Tank  
 B8 / Tank to c / Tank

Group ii) b / Tank to A8 / Tank  
 b / Tank to B8 / Tank  
 b / Tank to C8 / Tank

Group iii) C8 / Tank to a / Tank  
 C8 / Tank to b / Tank  
 C8 / Tank to c / Tank

Group iii) c / Tank to A8 / Tank  
 c / Tank to B8 / Tank  
 c / Tank to C8 / Tank

**b) Phase / Phase to Phase / Neutral mode:**

In this signalling mode the combination of connections is as follows ,

|            | <b>HV to LV Propagation</b>                              |            | <b>LV to HV Propagation</b>                              |
|------------|--|------------|--|
| Group i)   | A8 / B8 to a / n<br>A8 / B8 to b / n<br>A8 / B8 to c / n | Group i)   | a / n to A8 / B8<br>a / n to A8 / C8<br>a / n to B8 / C8 |
| Group ii)  | A8 / C8 to a / n<br>A8 / C8 to b / n<br>A8 / C8 to c / n | Group ii)  | b / n to A8 / B8<br>b / n to A8 / C8<br>b / n to B8 / C8 |
| Group iii) | B8 / C8 to a / n<br>B8 / C8 to b / n<br>B8 / C8 to c / n | Group iii) | c / n to A8 / B8<br>c / n to A8 / C8<br>c / n to B8 / C8 |

**c) Phase / Phase to Phase / Phase mode:**

Again , the following combination of connections are feasible in this signalling mode .

|          | <b>HV to LV Propagation</b>                              |          | <b>LV to HV Propagation</b>                              |
|----------|--|----------|--|
| Group i) | A8 / B8 to a / b<br>A8 / B8 to a / c<br>A8 / B8 to b / c | Group i) | a / b to A8 / B8<br>a / b to A8 / C8<br>a / b to B8 / C8 |

|            |  |            |  |
|------------|--|------------|--|
| Group ii)  | A8 / C8 to a / b<br>A8 / C8 to a / c<br>A8 / C8 to b / c | Group ii)  | a / c to A8 / B8<br>a / c to A8 / C8<br>a / c to B8 / C8 |
| Group iii) | B8 / C8 to a / b<br>B8 / C8 to a / c<br>B8 / C8 to b / c | Group iii) | b / c to A8 / B8<br>b / c to A8 / C8<br>b / c to B8 / C8 |

### 5.2.1 Preliminary Investigations One

The purpose of these preliminary investigations was to determine if any of the differing signalling modes and configurations exhibited similar frequency characteristics . This would eliminate the duplication of 'on site' tests which would otherwise be redundant . The following experimental programme was therefore performed on a 50kVA , Dyn11 transformer , sited in the laboratory at John Moores University , Liverpool .

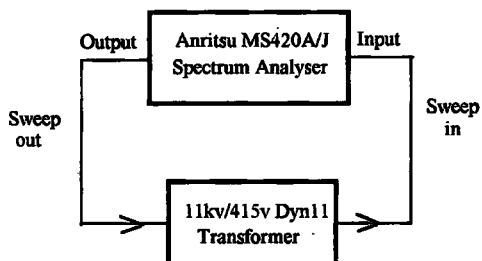

Fig 5.2.2: Preliminary Experiment set up .

In referring to fig 5.2.2 an Anritsu MS420A/J spectrum analyser was used to provide a signal sweep over the range 10Hz to 1MHz . The return signal at the spectrum analysers input could then be interpreted as a function of the transformers frequency response . This procedure was used to obtain the frequency characteristics of the signalling modes and configurations listed in section 5.2 . A cross section of these results are presented in appendix A and may be summarised as follows .



i) Phase / Tank to Phase / Tank mode:

All configurations of HV to LV signalling produced virtually identical frequency characteristics . This was also true for all LV to HV configurations and is highlighted by a composite plot of the frequency characteristics of all the configurations used in this signalling mode ( see fig 5.2.3 and fig 5.2.4 ) .

### Magnitude

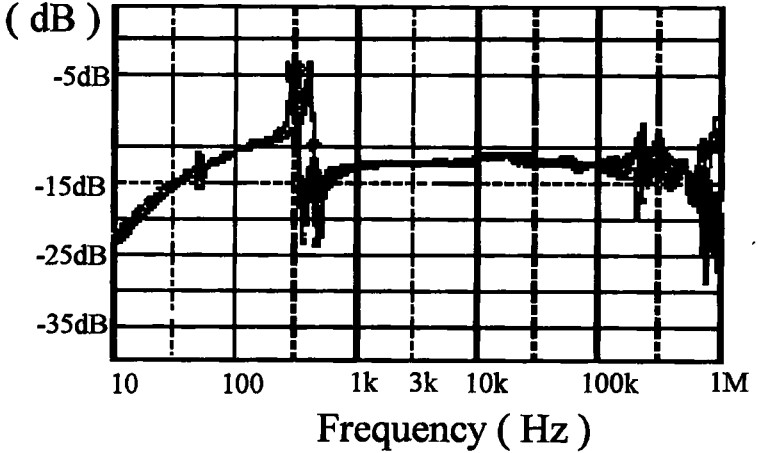

Fig 5.2.3: Composite plot of all HV to LV transmissions .

### Magnitude

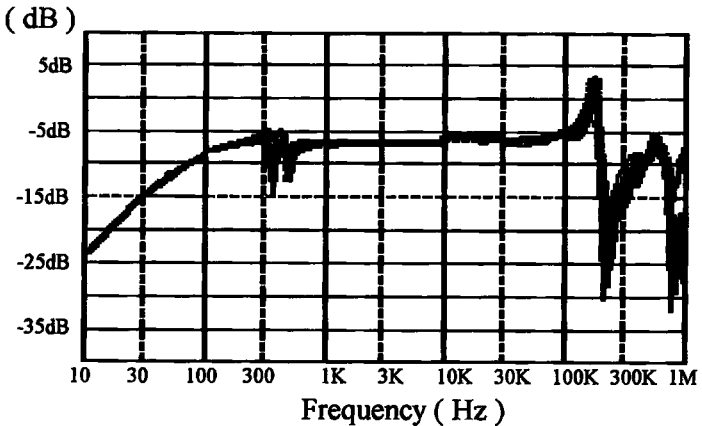

Fig 5.2.4: Composite plot of all LV to HV transmissions .

ii) Phase / Phase to Phase / Neutral mode:

It was found that over the frequency range 1kHz to 300kHz all configurations from HV to LV and LV to HV possessed very similar frequency characteristics . Fig 5.2.5 and fig 5.2.6 reveal this similarity by displaying the results as a composite plot . The maximum deviation between the plots of differing configurations is  $\approx 7\text{dB}$  , illustrated in fig 5.2.5 , which is present within a dynamic range of 45dB . This deviation is representative of 15% of the dynamic range , thus indicating a close similarity between the responses of different configurations . The effects and cause of this 'offset' between some of the configurations is analysed in detail in section 5.5.1.3 .

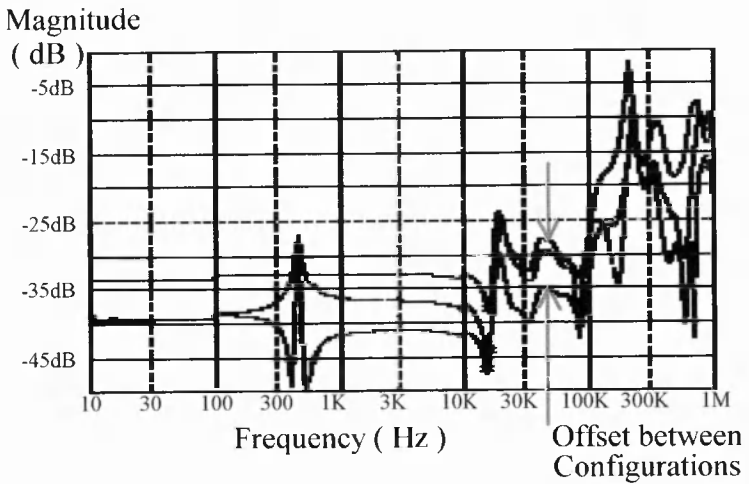

Fig 5.2.5: Composite plot of HV to LV transmissions .

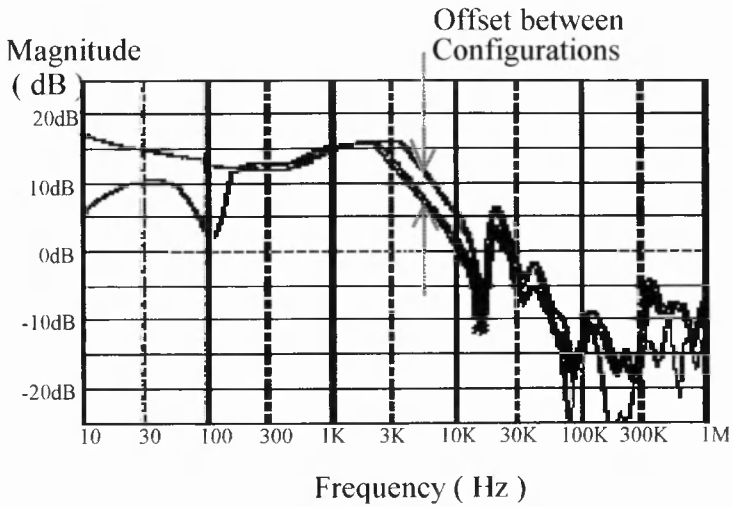

Fig 5.2.6. Composite plot of LV to HV transmissions .

iii) Phase / Phase to Phase / Phase mode .

Yet again , over the frequency range 1kHz to 300kHz the transformer exhibited very similar frequency characteristics in all configurations in HV to LV transmissions and LV to HV transmissions . A variation of 20% between different configurations over a dynamic range of 70dB is revealed in fig 5.2.7 . This observation illustrates the similarity between the frequency response of differing configurations within a signalling mode . The cause of the offset between the responses of different configurations is explained in section 5.5.1.3 .

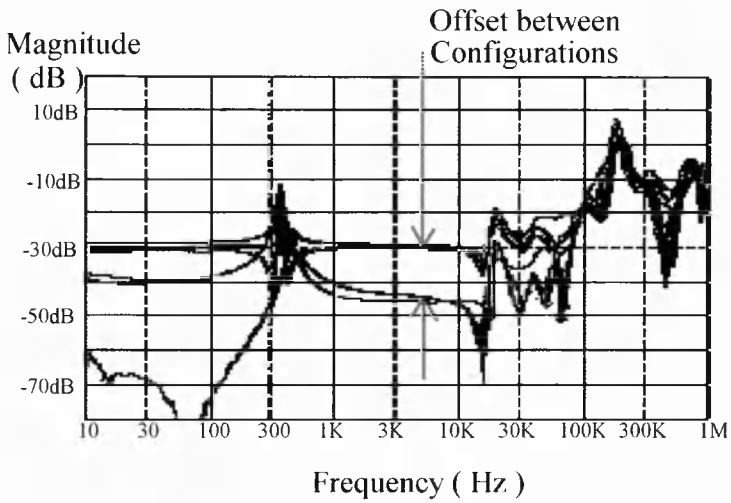

Fig 5.2.7: Composite plot of HV to LV transmissions .

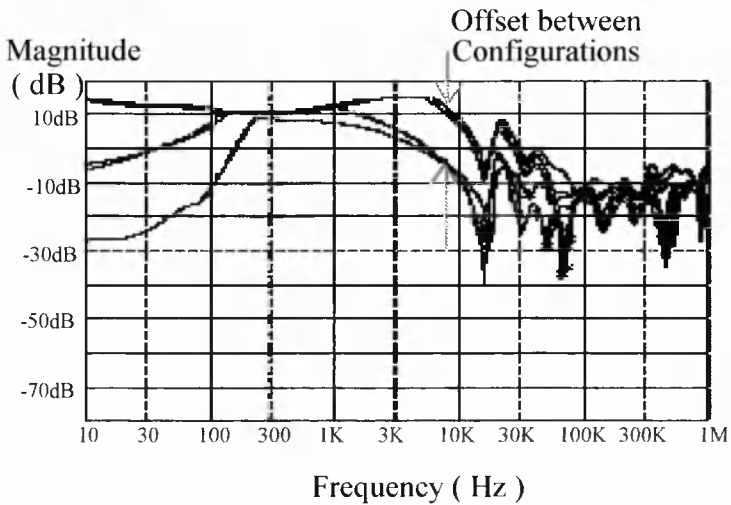

Fig 5.2.8: Composite plot of LV to HV transmissions .

### **5.2.2 Preliminary Investigations One - Conclusions**

The results of the preliminary investigations highlight the fact that each configuration of a particular signalling mode need not be studied in order to obtain an

understanding of the transformers propagation characteristics . This is due to the similar nature of frequency characteristics between different groups of configurations within a signalling mode . Results indicate that differences between responses in any signalling mode lie within a 20% band , this may be attributed to the symmetrical nature of the 3 phase Dyn11 transformer . The effect the transformers symmetry has on the propagation characteristics will be discussed in greater detail in section 5.5.1.3 . It may therefore be deemed only necessary to study the following modes and configurations of through transformer signalling .

a) Phase / Tank to Phase / Tank: ( Group i )

|                       |                       |
|-----------------------|-----------------------|
| A8 / Tank to a / Tank | a / Tank to A8 / Tank |
| A8 / Tank to b / Tank | a / Tank to B8 / Tank |
| A8 / Tank to c / Tank | a / Tank to C8 / Tank |

b) Phase / Phase to Phase / Neutral: ( Group i )

|                  |                  |
|------------------|------------------|
| A8 / B8 to a / n | a / n to A8 / B8 |
| A8 / B8 to b / n | a / n to A8 / C8 |
| A8 / B8 to c / n | a / n to B8 / C8 |

c) Phase / Phase to Phase / Phase: ( Group i )

|                  |                  |
|------------------|------------------|
| A8 / B8 to a / b | a / b to A8 / B8 |
| A8 / B8 to a / c | a / b to A8 / C8 |
| A8 / B8 to b / c | a / b to B8 / C8 |

### 5.3 Coupling Circuits

#### 5.3.1 Preliminary Investigations Two

The first set of 'on site' experiments , performed at GEC Alsthom Transformers , were concerned with a preliminary investigation regarding the coupling of test equipment to the LV and MV voltages . This approach was necessary in order to facilitate the study of the transformers characteristics in its energised state . As well as introducing the practices of working under high voltage conditions this preliminary on site experimental work would provide an insight into the facilities and procedures at GEC Alsthom .

In the preliminary visit to GEC Alsthom the available components and facilities permitted the design and construction of the following coupling circuits . The general form of coupling circuit is illustrated in fig 5.3.1 .

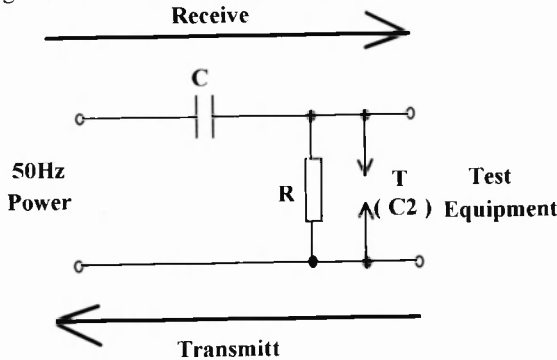

Fig 5.3.1 : Preliminary Coupling circuit outline .

Fig 5.3.1 shows the coupling circuit to be a passive high pass filter , with a high voltage capacitor 'C' providing a high impedance to 50Hz power frequency and low impedance to signal frequencies . In parallel with resistor 'R' is a 'transguard' voltage limiter which provides protection for the test equipment in case of capacitor failure . The transguard limiter possesses an inherent capacitance of 380pF ( C2 ) which may or may not be neglected , depending on the value of 'R' .

A closer analysis of the LV and MV coupling circuits is now provided .

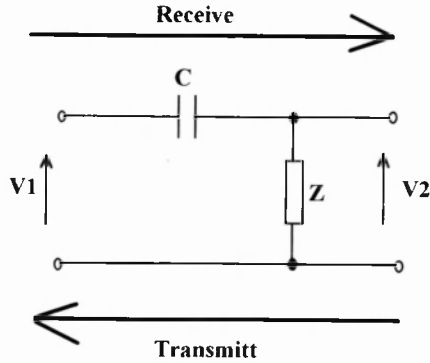

Fig 5.3.2 : LV / MV Coupling Circuit .

i) LV coupling circuit , referring to fig 5.3.2 ,

$$Z = R \text{ and } C_2 \text{ in parallel} = \frac{R * \frac{1}{j\omega C_2}}{R + \frac{1}{j\omega C_2}}$$

multiplying numerator and denominator by  $j\omega C_2$  we have ,

$$Z = \frac{R}{1 + j\omega C_2 R} , \text{ now if } \omega C_2 R \ll 1 \text{ ( as is the case at signalling frequencies ) ,}$$

then  $Z \approx R$  .

$$\text{Therefore the circuits transfer function , in receive mode , } \left( \frac{V_2}{V_1} \right) = \frac{R}{R + \frac{1}{j\omega C_1}}$$

multiplying numerator and denominator by  $j\omega C_1$  we have ,

$$\left( \frac{V_2}{V_1} \right) = \frac{j\omega C_1 R}{1 + j\omega C_1 R}$$

$$\text{Alternatively in transmit mode } \left( \frac{V_1}{V_2} \right) = \frac{1 + j\omega C_1 R}{j\omega C_1 R}$$

Where  $R = 306\Omega$  ,  $C_1 = 471\text{nF}$  and  $C_2 = 380\text{pF}$  .

ii) MV Coupling circuit , referring to fig 5.3.2 ,

In the MV coupling circuit the value of  $C_1$  must be decreased in order to increase its impedance to the higher 50Hz voltage ( 11kV ) . Unfortunately this increases its signal frequency impedance , thus requiring an increase in 'R' in order that an appreciable amount of signal voltage is dropped across this portion of the potential divider . Upon increasing 'R' the capacitive reactance of the transguard (  $C_2$  ) becomes significant at signal frequencies , due to its shunting effect on 'R', (  $\omega C_2 R \gg 1$  at signal frequencies ) .

Therefore the effect of  $C_2$  must be included in the circuits transfer function .

$$\text{In receive mode} \quad \left( \frac{V_2}{V_1} \right) = \frac{j\omega C_1 Z}{1 + j\omega C_1 Z}$$

$$\text{In transmit mode} \quad \left( \frac{V_1}{V_2} \right) = \frac{1 + j\omega C_1 Z}{j\omega C_1 Z}$$

$$\text{Where } Z = \frac{R}{1 + j\omega C_2 R}$$

and  $R = 6K\Omega$  ,  $C_1 = 580\text{pF}$  ,  $C_2 = 380\text{pF}$  .

The significance of the 'transguard' capacitance in this circuit highlights the limitation of the MV coupling circuit . Also by increasing the value of 'R' , to balance the greater reactance of  $C_1$  at signal frequencies , a greater portion of the 50Hz power wave is passed through to the test equipment . This factor limits the practical use of this circuit .

### **5.3.2 Preliminary Investigations Two - Conclusions**

The analysis of the coupling circuits reveals their limitation . Although the circuits provide adequate isolation for the connection of oscilloscopes and signal generators , a spectrum analysers input became overloaded at 50Hz . Closer investigation revealed that the spectrum analyser could only accept input signals up to 10V peak - peak . The circuits were modified by reducing the value of 'R' . Unfortunately this also reduced signal frequency levels .



The limitation of these circuits stems from the fixed values of series capacitors (  $C_1$  ). However at this stage these were the only values of high voltage capacitors available . With this in mind the need to design and construct a more adequate coupling circuit was apparent .

## **5.4 11kV and 415V Coupling**

Following the results obtained from the preliminary investigations of section 5.3 concerning the LV and MV coupling circuits , the next experimental procedure involved their redesign . The requirement of both LV and MV coupling circuits is to provide a pass band of negligible attenuation and phase shift in the signal frequency range , whilst attenuating the 50Hz power frequency to a voltage  $< 10V$  . In other words the coupling circuits must appear transparent to signal frequencies and at the same time block the 50Hz mains in order to facilitate the connection of test equipment .

### **5.4.1 Low Voltage Coupling**

An improvement in the original design was to use capacitive / inductive coupling rather than capacitive / resistive coupling . In theory this should produce a 'flatter' response in the pass band whilst providing greater attenuation to the 50Hz power component .

At this stage the realisation of the need for two similar LV and two similar MV coupling circuits was made . This would provide the means to investigate phase / phase signalling modes . As for the purpose of coupling circuit analysis , only one LV and one MV coupling circuit will be analysed .

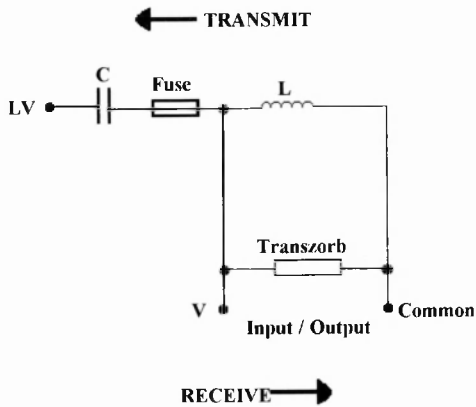

Fig 5.4.1: LV Coupling circuit .

The capacitor is selected to provide attenuation to the 50Hz power component whilst 'passing' the signal frequencies . The inductor provides a high impedance for signal recovery or signal source . Protection of any equipment connected to the output / input terminals is provided by the 'Tranzorb' . The Tranzorb is a device which will clamp a voltage surge to a predefined level , in this case approximately 10V . In the case of capacitor failure the tranzorb will limit the voltage at the output / input terminals . In this time instant , the extra current shunted by the tranzorb will blow the series fuse , hence isolating the circuit . Other than its protective role the tranzorb may be neglected in circuit operation . For the purpose of analysis the circuit may be re drawn .

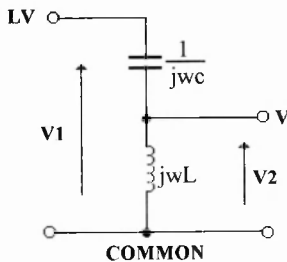

Fig 5.4.2: LV Coupling .

The circuits transfer function may now be derived ,

$$\begin{aligned} \frac{V_1}{V_2} &= \frac{1/j\omega C + j\omega L}{j\omega L}, \quad \text{Multiplying numerator and denominator by } j\omega C, \\ &= \frac{1+j^2\omega^2 CL}{j^2\omega^2 CL} \quad (\text{Now } j^2 \equiv -1) \\ &\therefore \frac{V_1}{V_2} = \frac{1-\omega^2 CL}{-\omega^2 CL} \end{aligned}$$

The transfer function implies constant phase response with a magnitude coefficient which tends towards 0dB at frequencies where  $\omega^2 CL \gg 1$  ( $f > 20\text{kHz}$ ). Due to the limited availability of capacitors which possess a voltage rating in excess of 250V, together with a high reactance at 50Hz, a 470nF, 250v 'X2' capacitor was chosen. A value of 1mH was empirically chosen for the inductance. These component values theoretically produce the following levels of attenuation.

$$\text{At } 50\text{Hz}, \quad \frac{V_1}{V_2} = \frac{1-\omega^2 CL}{-\omega^2 CL}$$

$$\text{Where } \omega^2 = 98.7 \cdot 10^3, \quad CL = 4.7 \cdot 10^{-10}$$

$$\therefore \frac{V_1}{V_2} = \frac{1-4.64 \cdot 10^{-5}}{-4.64 \cdot 10^{-3}} = 86.7 \text{ dB}$$

i.e., V2 will be 86.7 dB less than V1 at 50 Hz.

$$\text{At } 60\text{kHz}, \quad \omega^2 = 142.12 \cdot 10^9, \quad CL = 4.7 \cdot 10^{-10}$$

$$\therefore \frac{V_1}{V_2} = \frac{1-66.8}{-66.8} = \approx 1 = 0\text{dB}$$

i.e., V1 and V2 are approximately equal at 60 kHz.

The previous 'spot' frequency calculations indicate an attenuation of 86.7dB at 50Hz with a 0dB response at 60kHz . The effect of increasing the value of inductance has negligible effect in the signalling range , but decreased the degree of attenuation at 50Hz . A decision was therefore made to construct the coupling circuit using a 470nF capacitor and 1mH inductor . Circuit operation was subsequently verified with a spectrum analyser by obtaining the circuits frequency response from 10Hz to 1MHz . This response is shown in fig 5.4.3 , and reveals an attenuation of approximately 85dB at 50Hz whilst providing a flat response around 0dB between 10kHz and 300kHz .

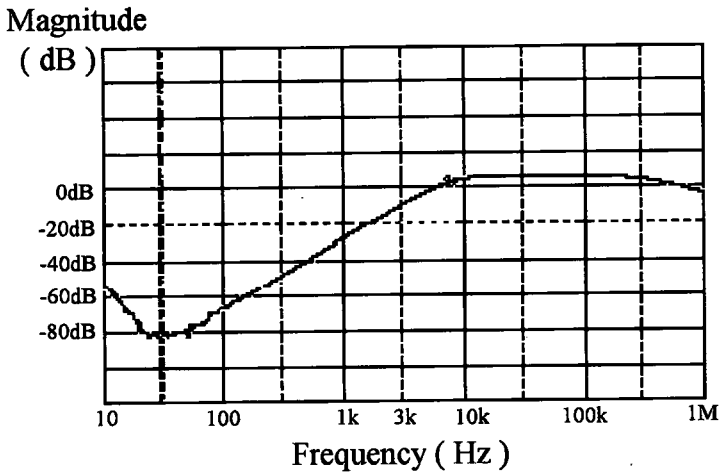

Fig 5.4.3: LV Coupling circuit frequency response .

### 5.4.2 Medium Voltage Coupling

As in the LV coupling circuit a capacitive / inductive circuit was utilised .

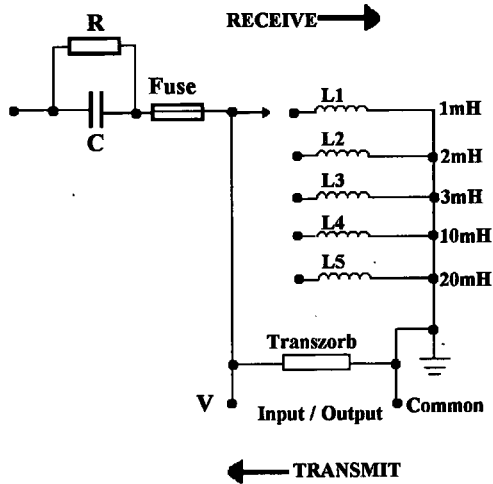

Fig 5.4.4: MV Coupling circuit .

In fig 5.4.4 the MV capacitor , rated in excess of 11kV , is selected to provide attenuation to the 50Hz power component whilst 'passing' the signal frequencies . The inclusion of 'bleed' resistance 'R' , in the MΩ range , has negligible effect on circuit operation . In the MV coupling circuits a range of inductors were included in order to provide a degree of 'tuning' , depending on the range of signal frequencies used . As in the case of the LV coupling circuit the inductor provides a high impedance for signal recovery / signal source , but a low impedance for the 50Hz power component . Circuit protection by Transzorb and fuse operates in the same manner as that of the LV coupling circuit .

The circuits transfer function is identical to that of the LV coupling circuit , namely ,

$$\frac{V1}{V2} = \frac{1 - \omega^2 CL}{-\omega^2 CL}$$

To ensure a 'safe' working voltage (  $V_2$  ), a decision was made to limit the 50Hz power component 'passed' by the circuit to less than 1 volt . In order to achieve this an attenuation in excess of  $\approx 80\text{dB}$  is required at 50Hz .

Yet again , a restriction is imposed by the availability of high voltage capacitors . In this case a  $9.42\text{nF}$  , rated in excess of  $11\text{kV}$  was used . Choosing the value of inductance empirically at  $20\text{mH}$  , the circuit provides the following attenuation levels at 50Hz and  $60\text{kHz}$  .

At 50Hz ,

Where  $C = 9.42\text{nF}$  ,  $L = 20\text{mH}$  and  $\omega^2 = 98.7 \cdot 10^3$

$$\frac{V_1}{V_2} = \frac{1 - 1.859 \cdot 10^{-5}}{-1.859 \cdot 10^{-5}} = 53778.5 = 94.6\text{dB}$$

i.e. ,  $V_2$  will be  $94.6\text{ dB}$  less than  $V_1$  at  $50\text{ Hz}$  .

At  $60\text{kHz}$  ,

Where  $\omega^2 = 142.122 \cdot 10^9$

$$\frac{V_1}{V_2} = \frac{1 - 26.8}{-26.8} \approx 1 = 0\text{dB}$$

i.e. ,  $V_1$  and  $V_2$  are approximately equal at  $60\text{kHz}$  .

The previous calculations indicate an attenuation of  $94.6\text{dB}$  at  $50\text{Hz}$  and  $0\text{dB}$  at  $60\text{kHz}$  . These levels of attenuation more than satisfy the coupling circuits specification . Circuit operation was verified with a spectrum analyser by obtaining the circuits frequency response . The frequency characteristics , shown in fig 5.4.5 , reveal an attenuation of approximately  $90\text{dB}$  at  $50\text{Hz}$  with a 'flat' response around  $0\text{dB}$  between  $20\text{kHz}$  and  $300\text{kHz}$  .

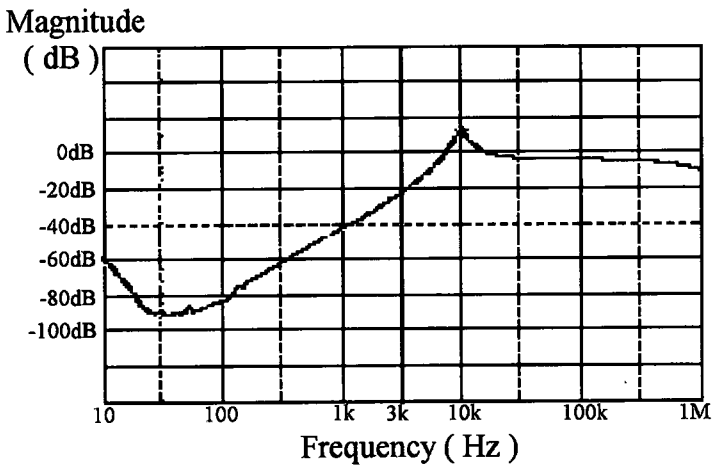

Fig 5.4.5: MV Coupling circuit frequency response .

## 5.5 Through Transformer Signalling Bands

When considering a communications architecture which involves through transformer signalling ( fig 1.13 , section 1.5 , chapter 1 ) , differing forms of transmissions may be realised , namely , narrowband and wideband in both coherent and non coherent form . The different characteristics associated with these types of system create two sets of through transformer transmission pass bands . Therefore a separate approach must be adopted in order to determine these differing pass bands .

### 5.5.1 Non Coherent and Coherent Narrowband

With reference to a PLC a non coherent transmission is one in which there is no requirement for a phase matched synchronisation between the receivers reference and the received transmission . A non coherent detector and receiver makes use of the carriers envelope for signal interpretation . In other words the phase frequency characteristics of the transmission channel , including the transformer , do not influence or impair signal transmission and reception . With this in mind , any degradation in signal reception is due to the magnitude of attenuation of the carrier . In severe cases the magnitude of

attenuation of a channel may reduce the carriers amplitude to a magnitude which is undetectable at the receivers input . This is an extreme condition which must be accounted for when determining the pass bands associated with a through transformer signalling system . In the following work a pass band may be defined as a frequency range which permits the reliable transmission and reception of a PLC . The degree of reliability is related to an acceptable bit error rate ( BER ) which may be tolerated . In addition , the BER is related to the signal to noise ratio ( SNR ) present at the receivers input , which in turn depends on the modulation scheme used .

Taking all these factors into consideration a communications system must be designed for worst case conditions in order that it remain operational at all times . Any positive departure from these worst case conditions will merely result in enhanced system performance , reflected by a decrease in bit error rate .

Before the transformer pass bands may be established , the permissible bit error rate which the system must not exceed , must be determined . The IEC document concerning distribution automation using distribution line carrier systems , [82] , lays down guidelines for acceptable bit error rates . The IEC state that a transceiver should be designed to ensure a bit error rate not worst than 1 in  $10^3$  . This opinion is reiterated by Dixon [72] . On the contrary a system for use on 275kV transmission lines , described by Thompson & Olsen [83] outlines a BER requirement of 1 in  $10^5$  . Of course , a reduction in error rate may be 'artificially' achieved using error correction schemes [17],[69] . Although any viable communication system would employ such schemes , it is the modulation technique which is to be analysed , not the complexities of message protocol .

Bearing all these factors in mind , the existence of several opinions regarding permissible transmission error rates is evident . In order to compromise these differing opinions a bit error rate of no more than 1 in  $10^4$  is deemed acceptable for the purpose of this research . In achieving such BER's a degree of SNR must be present ( at the receiver ) which varies with the type of modulation technique . Table 5.5.1 , courtesy of Cooper &



McGillem [73] , presents the various levels of SNR which must exist in order that the different modulation techniques may achieve a bit error rate no greater than  $1 \text{ in } 10^4$  .

| <b>Modulation Scheme</b>      | <b>Required SNR ( for BER of <math>1 \text{ in } 10^4</math> )</b> |
|-------------------------------|--|
| OOK - Coherent detection      | <b>11.4 dB</b>   |
| OOK - Envelope detection      | <b>11.9 dB</b>   |
| QAM                           | <b>8.4 dB</b>  |
| FSK - Coherent detection      | <b>7.4 dB</b>  |
| FSK - Non Coherent detection  | <b>12.5 dB</b>   |
| BPSK - Coherent detection     | <b>8.4 dB</b>  |
| DPSK - Previous bit reference | <b>9.3 dB</b>  |
| QPSK                          | <b>8.4 dB</b>  |
| DQPSK                         | <b>10.7 dB</b>   |
| <i>16 array PSK</i>           | <b><i>16.2 dB</i></b>  |

Table 5.5.1: SNR for  $1 \text{ in } 10^4$  BER .

In table 5.5.1 the SNR for coherent systems is also presented . It should be noted that for the same bit error rate a coherent system requires a lower SNR . This is largely due to the receiver making use of the carriers phase in order to distinguish it from the noise . Although coherent systems rely on synchronisation of phase between the carrier and locally generated reference , a fixed phase offset in the communications channel should not impair a phase lock detector . After initial phase lock is established , tracking remains relatively simple due to the fixed phase offset at the carrier frequency . Obviously a wideband coherent system would encounter difficulty in phase tracking across a bandwidth of differing phase offsets . This topic of discussion , associated with spread spectrum systems , is reserved for section 5.5.2.4.

With all this in mind it would seem logical to group narrowband coherent systems with narrowband non coherent systems , as done in table 5.5.1 .

In adopting the 'worst' SNR ( excluding 16 array PSK , as this is an unlikely candidate for a PLC ) , non coherent FSK requires the greatest SNR for a 1 in  $10^4$  BER . It may therefore be deemed necessary for a signal to be at least 12.5 dB above the noise level , at the receiver input , to maintain the required bit error rate .

### 5.5.1.1 Signalling Levels

Obviously the greater the signal voltage , which is injected onto the mains distribution network , the greater is the chance of the signal propagating through the transformer . Of course the European standard EN50065-1 , [25] , places an upper limit on signal levels of  $134\text{dB}\mu\text{V}$  , which corresponds to  $5.01\text{V}$  . The signal level which the detector of a receiver must 'see' , must appear above the background noise by at least the SNR stated in the previous section ( 12.5 dB ) . Although narrow band noise exists at levels far in excess of background noise , its effects may be neglected due to its predictable nature . After all , the choice of carrier frequency would not be chosen to coincide with a narrow band interferer such as the television scan frequency or switch mode power supply switching frequency . With reference to chapter 3 , section 3.7.1 , typical background noise levels may be as high as  $7\text{mV rms}$  (  $\approx 10\text{mV pk}$  ) . Therefore a viable signal must be 12.5 dB greater than  $10\text{mV}$  in order to facilitate reliable reception .

$$\therefore 10\text{mV} + 12.5 \text{ dB} = 10\text{mV} * 4.22 = \underline{42\text{mV}}$$

This gives rise to the minimum signal level required at receiver input .

In arranging the test equipment as in fig 5.2.2 , section 5.2.1 , the conditions are present to measure the absolute attenuation presented by the transformer . In this set up the spectrum analyser compares the output signal which it generates , with the return signal which has passed through the transformer . The absolute attenuation measurement in decibels is therefore a measure of the insertion loss presented by the transformer to a potential signalling system . Fig 5.5.2 therefore represents the signal levels at transmitter and receiver , on either side of the transformer .

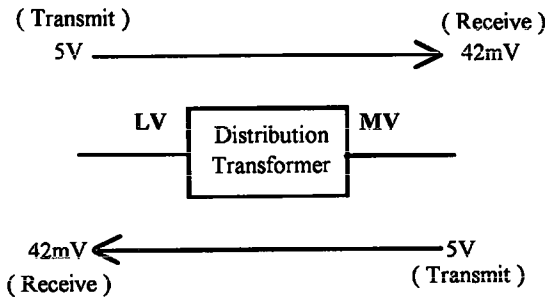

Fig 5.5.2 Signalling levels .

In fig 5.5.2 the assumption has been made that maximum signal levels injected on the MV network will not exceed 5V . This of course is a conservative estimate as MV signal levels will in practice be greater than this . However it will be representative of a worst case condition . Fig 5.5.2 is also representative of a system which provides signal injection and reception in close proximity to the transformers LV and MV terminals.. In a 'real' system , transceivers may be placed tens of meters away from the transformer . Unfortunately the forthcoming experimental work is not able to account for such an arrangement , in any case the scope of these investigations are concerned with the transformers contribution to signal attenuation , not that of the network .

Using the signal levels of fig 5.5.2 , the maximum attenuation which the transformer may present to the signals path may be calculated .

$$\begin{aligned} \text{Attenuation in dB} &= 20\log_{10} \left( \frac{\text{Signal transmitted}}{\text{Signal received}} \right) \\ &= 20\log_{10} \frac{5V}{42mV} = \underline{\underline{41.5 \text{ dB}}} \end{aligned}$$

Therefore if the transformer introduces more than  $\approx 40$  dB of attenuation , at the carrier frequency , the receiver will not be capable of interpreting the carrier . This reasoning may now be applied to determine the appropriate transformer pass bands .

### 5.5.1.2 Experimental Work One: Unenergised Passbands .

In order to clearly establish the through signalling bands of the transformer , the frequency characteristics , displayed in the form shown in section 5.2.1 , must firstly be transposed into a more 'manageable' format . This approach will allow results to be displayed on a common scale over a range 1kHz to 300kHz . This methodology is demonstrated using the 50 kVA transformer in phase / phase / phase / neutral signalling mode in its unenergised state .

Fig 5.5.3 illustrates the expanded frequency characteristics of the transformer between phases A8 / B8 and a / n , from 1kHz to 300kHz . The frequency bands of attenuation at -30dB and -40dB are marked on the response . These 'bands' of attenuation may now be 'transposed' onto a more dynamic attenuation range to enable comparison with other transformer responses . This process is illustrated in fig 5.5.3a .

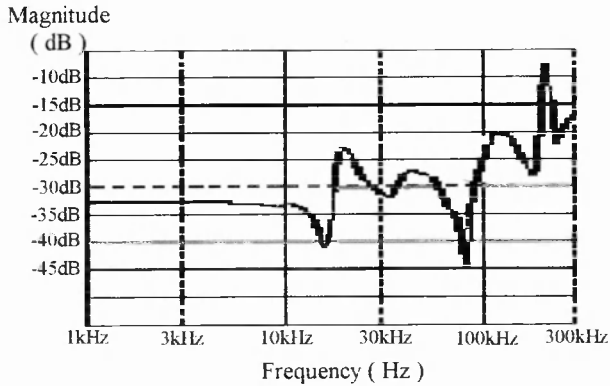

Fig 5.5.3 : Frequency Response , Phases A8 / B8 to Phase a / n .

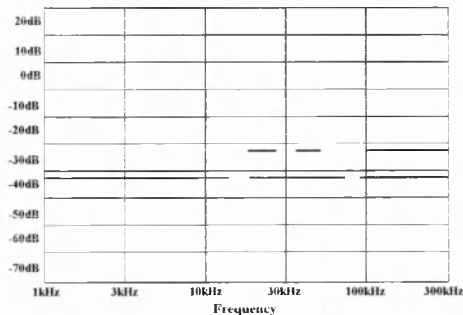

Fig 5.5.3a: Transposed Plot , Phases A8 / B8 to phase a / n .

In addition , this process is performed on the frequency responses of A8 / B8 to b/n and A8 / B8 to c / n , illustrated in figures 5.5.4 / 5.5.4a , and 5.5.5 / 5.5.5a respectively

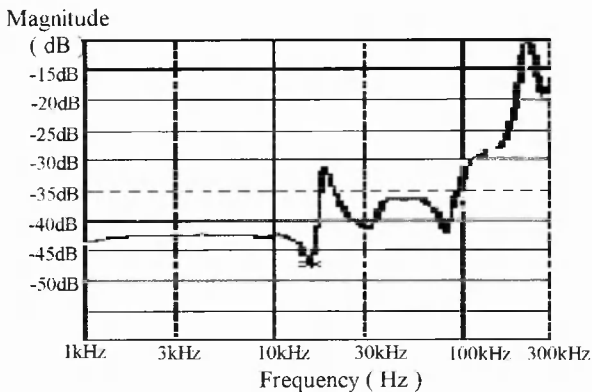

Fig 5.5.4 : Frequency Response , Phases A8 / B8 to Phase b / n .

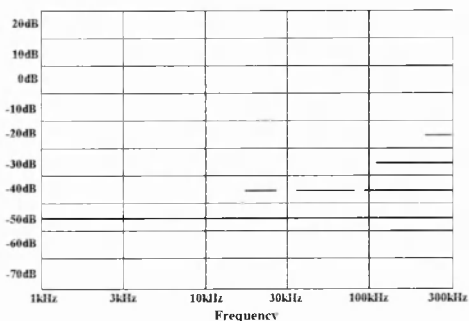

Fig 5.5.4a: Transposed Plot , Phases A8 / B8 to phase b / n .

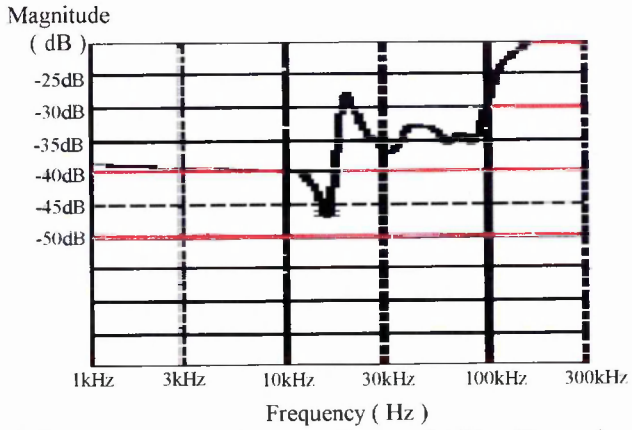

Fig 5.5.5 : Frequency Response , Phases A8 / B8 to Phase c / n .

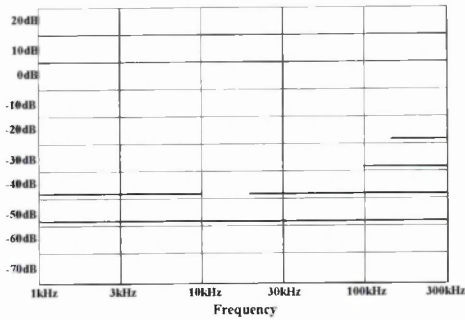

Fig 5.5.5a: Transposed Plot , Phases A8 / B8 to phase c / n .

These results may now be combined in the form of a composite plot of fig 5.5.6 , where the attenuation levels of different connections may be compared . In addition to the comparison of attenuation levels a basis has now been formed for identifying the transformers through signalling pass bands .

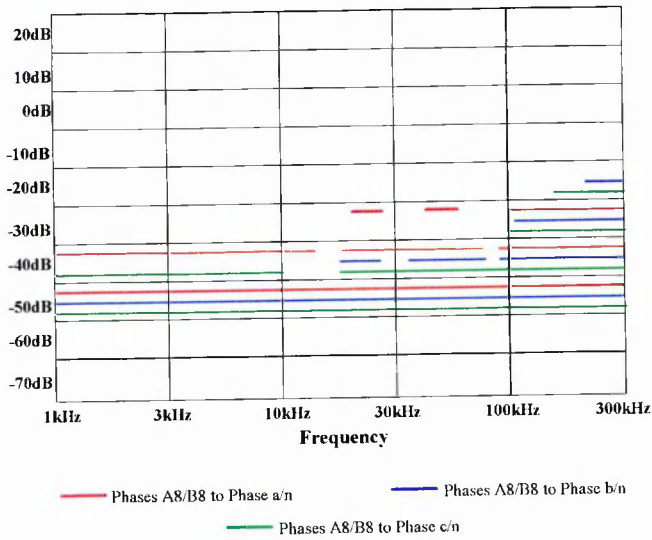

Fig 5.5.6 : Composite plot of HV to LV attenuation .

With reference to section 5.5.2 , an attenuation level greater than 40dB may not be considered a pass band . Furthermore , signal pass bands which are common to the different connection configurations , within a signalling mode , must be identified . This procedure is illustrated in fig 5.5.7 by the shaded areas .

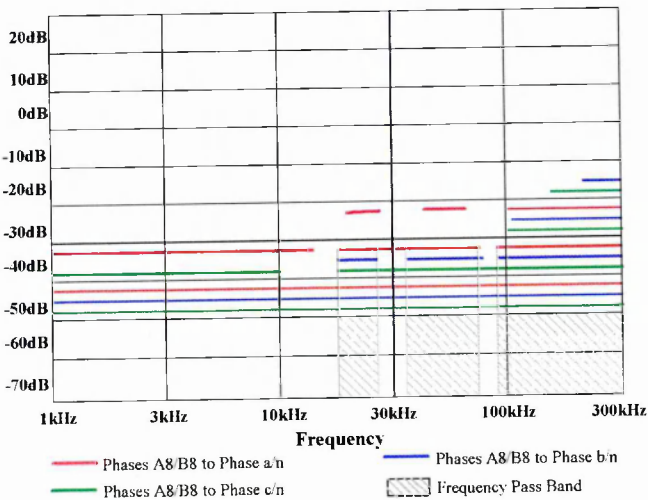

Fig 5.5.7 : HV to LV ( phase/phase to phase/neutral ) pass bands .

To reiterate this approach , the pass bands from LV to HV are now identified .

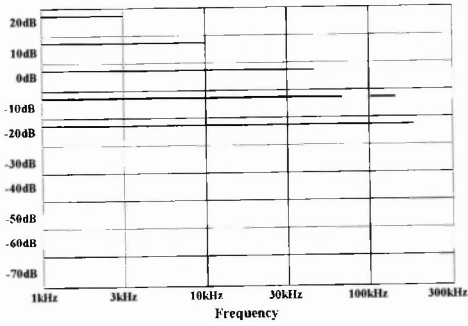

Fig 5.5.8 : Phase a/n to phases A8/B8 .

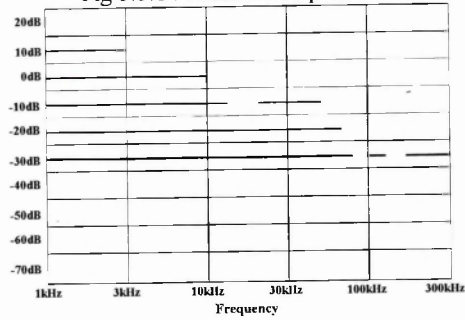

Fig 5.5.9 : Phase a/n to phases A8/C8 .

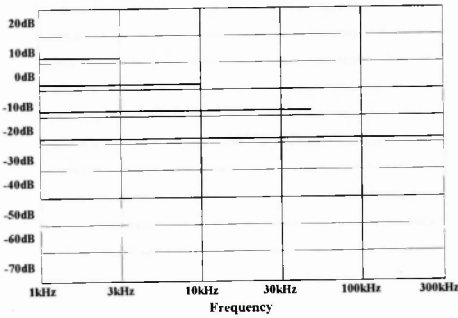

Fig 5.5.10 : Phase a/n to phases B8/C8 .

Now , combining these results in the form of a composite plot ,



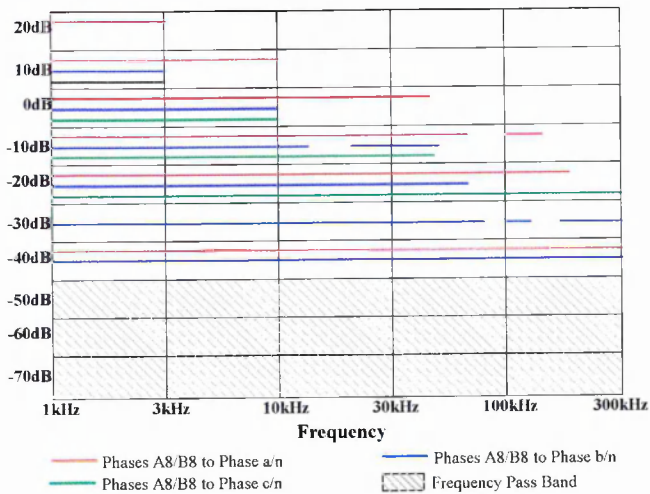

Fig 5.5.11 : Composite plot of LV to HV Pass bands .

Fig 5.5.11 also indicates the signalling pass bands ( shaded region ), which in this case extend from 1kHz to 300kHz .

This Experimental procedure is performed on the following distribution transformers using the signalling modes listed in table 5.5.2 .

| Transformer             | Signalling Mode                                 | Core Type       |
|-------------------------|---|-----------------|
| 50 kVA                  | Phase/Tank , Phase / Neutral ,<br>Phase / Phase | Conventional    |
| 1000 kVA                | Phase/Tank , Phase / Neutral ,<br>Phase / Phase | Conventional    |
| 400 kVA                 | Phase/Tank , Phase / Neutral ,<br>Phase / Phase | Amorphous Steel |
| 1600 kVA #1             | Phase/Tank , Phase / Neutral ,<br>Phase / Phase | Conventional    |
| 1600 kVA #2             | Phase/Tank , Phase / Neutral ,<br>Phase / Phase | Conventional    |
| 25 kVA ( single phase ) | Phase/Tank , Phase / Neutral                    | Amorphous Steel |

Table 5.5.2 : Transformers / Signalling modes investigated .

**Note:** All transformers listed in table 5.5.2 are of the three phase , 415V/11kV , Dyn11 type , except for the 25 kVA single phase , pole mount , transformer . In addition , the 400kVA transformer is of 410V/20kV rating ( for use on EDF network ) .

The frequency response plots of the various transformers in the different signalling modes , together with their transposed attenuation / frequency plots , are presented in appendix B . Although not all of the plots are presented in appendix B , as this would be too exhaustive , the cross section of plots provides a basis for introducing a composite pass band plot of all the transformers .

The signalling pass bands of each transformer , in a defined signalling mode , may now be presented in a composite plot to enable comparison between transformers .

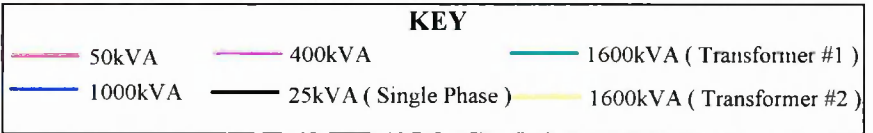
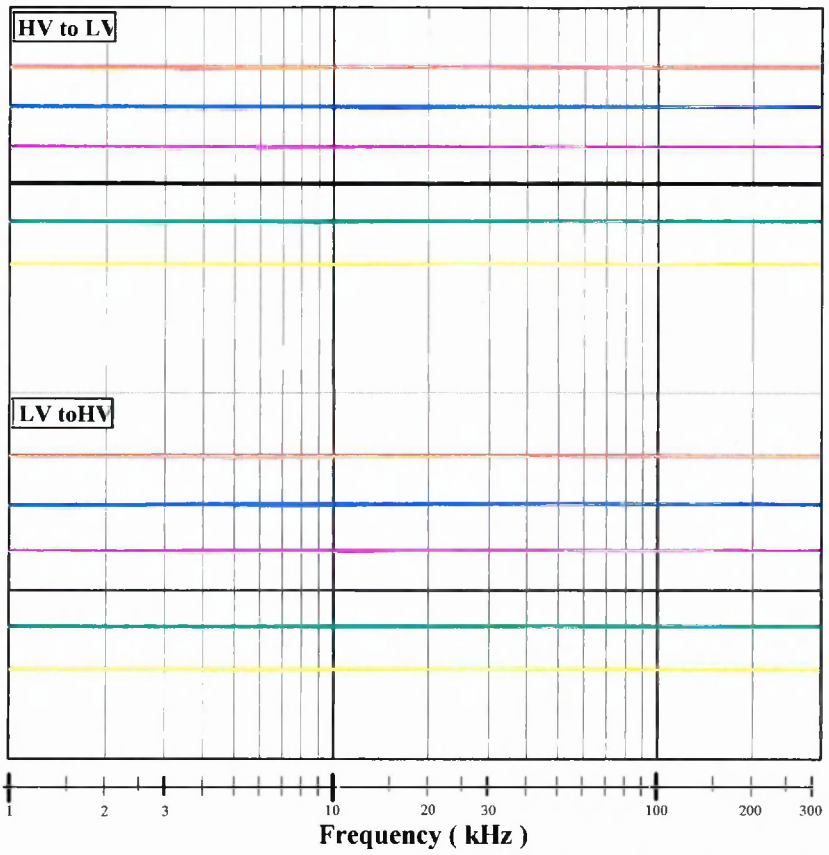

Fig 5.5.12 : Unenergised Phase / Tank to Phase / Tank , Pass bands .

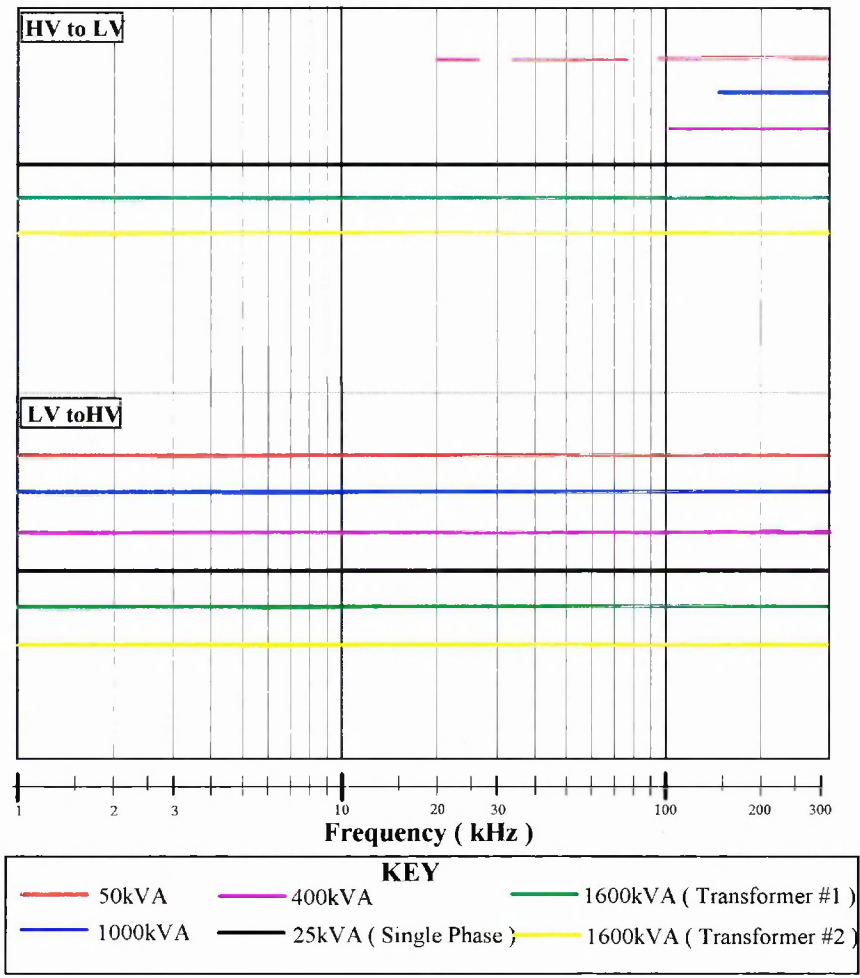

Fig 5.5.13 :Unenergised Phase / Phase to Phase / Neutral , Pass bands .

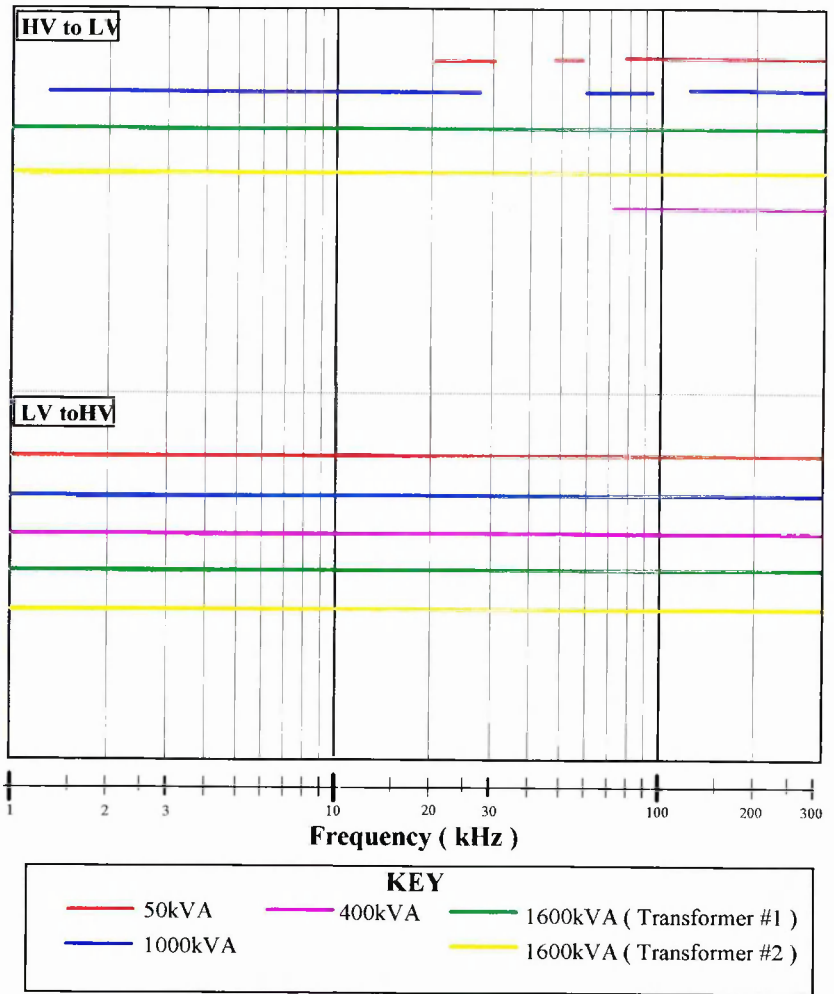

Fig 5.5.14 :Unenergised Phase / Phase to Phase / Phase , Pass bands .

### 5.5.1.3 Experimental Work One - Findings

Upon analysing the results presented in the previous section , the following observations were made .

a) Three phase transformer symmetry: Relationship between different configurations within a signalling mode .

Following the preliminary investigations of section 5.2.2 , the results obtained from the further investigations of section 5.5.1.2 may now be used to analyse the relationship between different terminal connections in the same signalling mode .

i) Phase / Tank to Phase / Tank Signalling mode .

The most striking characteristic of the frequency response in this particular mode is the virtually identical nature of the frequency responses of different phase / tank configurations ( with respect to each transformer ) . This characteristic holds true for all the transformers investigated ( see table 5.5.2 ) . Fig 5.5.15 looks at this characteristic more closely .

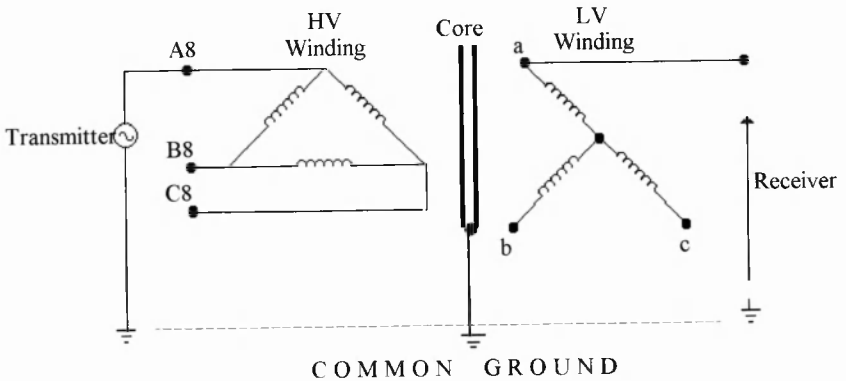

Fig 5.5.15 Phase / Tank Signalling .

The very nature of this signalling mode implies a common signalling ground . Fig 5.5.15 illustrates A8 / T to a / T connections . Results indicate that no matter which HV terminal is used for transmitter connection , propagation characteristics remain identical , even upon changing the receiver terminal connection . The complement of these results is true when signalling from LV to HV .

As the tank connection is common , and each phase connection provides identical propagation characteristics , the manner in which each phase couples the signal from one winding to the other must also be similar . As there is no circulating signal path in either winding , signal coupling must be capacitive in nature . This would imply the existence of capacitance between HV and LV windings which are wound on a common core leg .

ii) Phase / Phase to Phase / Neutral Signalling mode .

In this signalling mode the symmetrical nature of the Dyn11 transformer winding connections leads to a 'pattern' of similarities associated with different configurations . This is best explained with the aid of fig 5.5.16 .

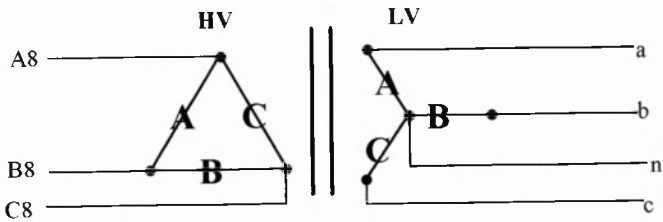

Fig 5.5.16 : Phase / Neutral Signalling .

In fig 5.5.16 the convention of marking windings which are wound on the same core leg by their respective core leg letters has been adopted . For example the winding between terminals A8 and B8 is wound on the same core leg as that of the a / n winding . With this in mind it would seem feasible that a signal injected between terminals A8 and B8 would be coupled more efficiently to the LV phase a / n , rather than the other LV phases . This is not only due to the close proximity of windings ( as they are on the same

core leg), but also because of the potential divider action of the delta winding (i.e. current will be greater in HV winding 'A' than windings 'B' and 'C' by the ratio 2:1). This reasoning is verified by examining the results from the 50 kVA transformer characteristics in appendix A, together with the characteristics obtained from the transformers of table 5.5.2 (appendix B).

The configurations which provide the lowest levels of attenuation, with similar frequency characteristics, are the common phase windings of: A8 / B8 to a / n, A8 / C8 to c / n and B8 / C8 to b / n.

All other configurations provide a greater degree of attenuation, but also possess similar frequency characteristics. These are:

- |                  |                  |                  |
|------------------|------------------|------------------|
| A8 / B8 to b / n | A8 / C8 to a / n | B8 / C8 to a / n |
| A8 / B8 to c / n | A8 / C8 to b / n | B8 / C8 to c / n |

When considering LV to HV transmissions, fig 5.5.16 must be re-examined. In this case a signal injected between LV terminal 'a' and neutral will only pass through the winding on LV phase 'A'. The propagation results from all possible configurations in this mode constantly showed worst signal propagation from the LV phase of injection, to the HV phase physically sited the greatest distance from the LV phase of injection (see fig 5.5.17).

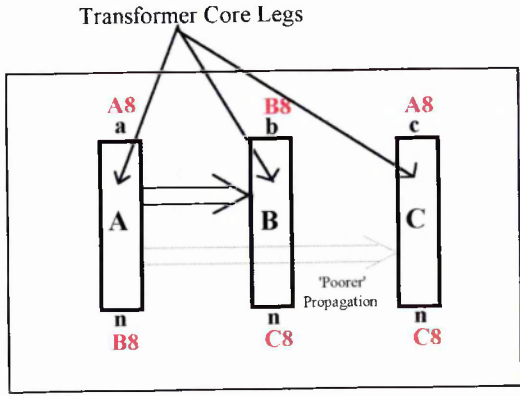

Fig 5.5.17: Transformer phases, physical separation.



In other words because phase 'C' is sited a greater distance from phase 'A' than phase 'B' is , it can be expected that propagation characteristics from a / n to A8 / C8 be poorer than from a / n to A8 / B8 and a / n to B8 / C8 . As expected , results showed that if a signal is injected on LV phase b/n ( central phase leg ) , it propagates equally to phase windings A and C ( HV phases A8 / B8 and A8 / C8 respectively ) . Examination of all possible signalling configurations in this mode , on different transformers , have verified these findings . The signal coupling in this mode of signalling is expected to be inductive in nature at lower frequencies and capacitive in nature at higher frequencies . This may be attributed to the lower reactance of phase windings , at lower frequencies , favouring greater signal current for inductive signal coupling . On the contrary , the greater winding reactance at higher frequencies favours the capacitive coupling of winding capacitance .

NOTE: The physical construction of the transformer ( section 3.5.1 ) complements this reasoning .

### iii) Phase / Phase to Phase / Phase Signalling mode .

The similarities between different signalling configurations in this mode bears resemblance to the phase / neutral mode . Consider a HV to LV transmission with the signal applied to HV terminals A8 / B8 ( see fig 5.5.16 ) . In this configuration the majority of signal will be coupled to LV phase 'A' . The corresponding received signal will therefore be greatest between phases 'a' and 'b' or 'a' and 'c' ( because phase 'A' is common to these connections ) . On the contrary , less signal is coupled to phases 'B' and 'C' resulting in 'poorer' propagation from A8 / B8 to b / c .

The results from all other signalling configurations examined on the 50 kVA transformer , together with the frequency characteristics of the transformers listed in table 5.5.2 , confirm these findings . This may now be summarised .

The configurations which provide greater levels of attenuation , with similar frequency characteristics are :

A8 / B8 to b / c      A8 / C8 to a / b      B8 / C8 to a / c

All other configurations provide a lesser degree of attenuation but possess similar frequency characteristics. These are :

A8 / B8 to a / b      A8 / C8 to a / c      B8 / C8 to a / b  
A8 / B8 to a / c      A8 / C8 to b / c      B8 / C8 to b / c

In considering LV to HV transmissions, a similar reasoning may be applied. A signal injected between LV phases 'a' and 'b' will circulate through LV phase windings 'A' and 'B'. These two phase signals will then be coupled to HV phase windings 'A' and 'B'. It would therefore be expected that greater signal reception would occur between HV phases A8 / B8 and B8 / C8. As less signal coupling to phase 'C' occurs, it would be expected that less signal is present between HV terminals A8 and C8. Yet again this reasoning was confirmed by the 50 kVA transformers frequency characteristics ( in all configurations ), together with results obtained from a variety of transformers ( see table 5.5.2 ).

The configurations which provide lower levels of attenuation, with similar frequency characteristics are :

a / b to A8 / B8      a / c to A8 / B8      b / c to A8 / C8  
a / b to B8 / C8      a / c to A8 / C8      b / c to B8 / C8

All other configurations provide a greater degree of attenuation but possess similar frequency characteristics. These are :

a / b to A8 / C8      a / c to B8 / C8      b / c to A8 / B8

#### b) Frequency Characteristics : Dynamic Range .

An important aspect concerned with signal transmissions is that of the dynamic range encountered in the signalling channel. With respect to through transformer signalling, the dynamic range is a function of the 'peaks' and 'troughs' present in the

transformers frequency characteristic profile . The following table ( table 5.5.3 ) summarises the dynamic range ( including peaks and troughs of the transformers examined in table 5.5.2 , section 5.5.1.2 .

| <b>Transformer</b> | <b>Signalling Mode</b> | <b>Peak ( dB )</b> | <b>Trough ( dB )</b> | <b>Dynamic Range</b> |
|--------------------|------------------------|--------------------|----------------------|----------------------|
| <b>50 kVA</b>      | Phase/Tank , HV to LV  | -12                |                      | <b>± 1 dB</b>        |
| <b>50 kVA</b>      | Phase/Tank , LV to HV  | -7                 |                      | <b>± 1 dB</b>        |
| <b>50 kVA</b>      | Phase/Neut , HV to LV  | -20                | -60                  | <b>40 dB</b>         |
| <b>50 kVA</b>      | Phase/Neut , LV to HV  | 5                  | -30                  | <b>35 dB</b>         |
| <b>50 kVA</b>      | Phase/Phase , HV to LV | -10                | -60                  | <b>50 dB</b>         |
| <b>50 kVA</b>      | Phase/Phase , LV to HV | 10                 | -30                  | <b>40 dB</b>         |
| <b>1000 kVA</b>    | Phase/Tank , HV to LV  | -12                |                      | <b>± 1 dB</b>        |
| <b>1000 kVA</b>    | Phase/Tank , LV to HV  | -8                 |                      | <b>± 1 dB</b>        |
| <b>1000 kVA</b>    | Phase/Neut , HV to LV  | -30                | -50                  | <b>20 dB</b>         |
| <b>1000 kVA</b>    | Phase/Neut , LV to HV  | 0                  | -40                  | <b>40 dB</b>         |
| <b>1000 kVA</b>    | Phase/Phase , HV to LV | -25                | -55                  | <b>30 dB</b>         |
| <b>1000 kVA</b>    | Phase/Phase , LV to HV | 0                  | -40                  | <b>40 dB</b>         |
| <b>400 kVA</b>     | Phase/Tank , HV to LV  | -14                |                      | <b>± 1 dB</b>        |
| <b>400 kVA</b>     | Phase/Tank , LV to HV  | -6                 |                      | <b>± 1 dB</b>        |
| <b>400 kVA</b>     | Phase/Neut , HV to LV  | -30                | -48                  | <b>18 dB</b>         |
| <b>400 kVA</b>     | Phase/Neut , LV to HV  | 0                  | -30                  | <b>30 dB</b>         |
| <b>400 kVA</b>     | Phase/Phase , HV to LV | -20                | -48                  | <b>28 dB</b>         |
| <b>400 kVA</b>     | Phase/Phase , LV to HV | 0                  | -30                  | <b>30 dB</b>         |
| <b>25 kVA</b>      | Phase/Tank , HV to LV  | -18                |                      | <b>± 1 dB</b>        |
| <b>25 kVA</b>      | Phase/Tank , LV to HV  | -12                |                      | <b>± 1 dB</b>        |
| <b>25 kVA</b>      | Phase/Neut , HV to LV  | -20                | -32                  | <b>12 dB</b>         |
| <b>25 kVA</b>      | Phase/Neut , LV to HV  | 0                  | -15                  | <b>15 dB</b>         |
| <b>1600 kVA #1</b> | Phase/Tank , HV to LV  | -10                | -15                  | <b>5 dB</b>          |

|                    |                       |     |     |               |
|--------------------|-----------------------|-----|-----|---------------|
| <b>1600 kVA #1</b> | Phase/Tank , LV to HV | -5  | -10 | <b>5 dB</b>   |
| <b>1600 kVA #1</b> | Phase/Neut ,HV to LV  | -8  |     | <b>± 1 dB</b> |
| <b>1600 kVA #1</b> | Phase/Neut ,LV to HV  | -5  | -14 | <b>9 dB</b>   |
| <b>1600 kVA #1</b> | Phase/Phase ,HV to LV | -8  |     | <b>± 1 dB</b> |
| <b>1600 kVA #1</b> | Phase/Phase ,LV to HV | -5  | -14 | <b>9 dB</b>   |
| <b>1600 kVA #2</b> | Phase/Tank , HV to LV | -12 | -15 | <b>3 dB</b>   |
| <b>1600 kVA #2</b> | Phase/Tank , LV to HV | -7  | -12 | <b>5 dB</b>   |
| <b>1600 kVA #2</b> | Phase/Neut ,HV to LV  | -10 | -12 | <b>2 dB</b>   |
| <b>1600 kVA #2</b> | Phase/Neut ,LV to HV  | -7  | -12 | <b>5 dB</b>   |
| <b>1600 kVA #2</b> | Phase/Phase ,HV to LV | -10 | -12 | <b>2 dB</b>   |
| <b>1600 kVA #2</b> | Phase/Phase ,LV to HV | -8  | -12 | <b>4 dB</b>   |

Table 5.5.3 Transformer Dynamic Range .

The data listed in table 5.5.3 may now be presented in the form of a histogram in fig 5.5.18a ( HV to LV propagation ) and fig 5.5.18b ( LV to HV propagation ) .

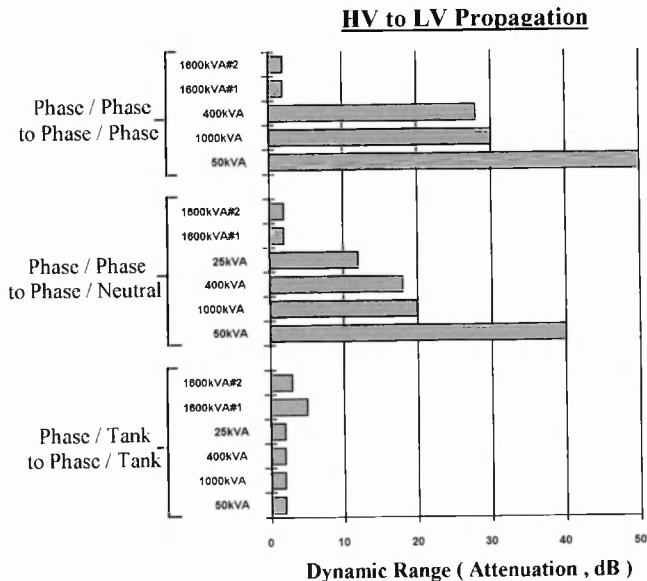

Fig 5.5.18a : Transformer Dynamic Range ( HV to LV , Unenergised ) .

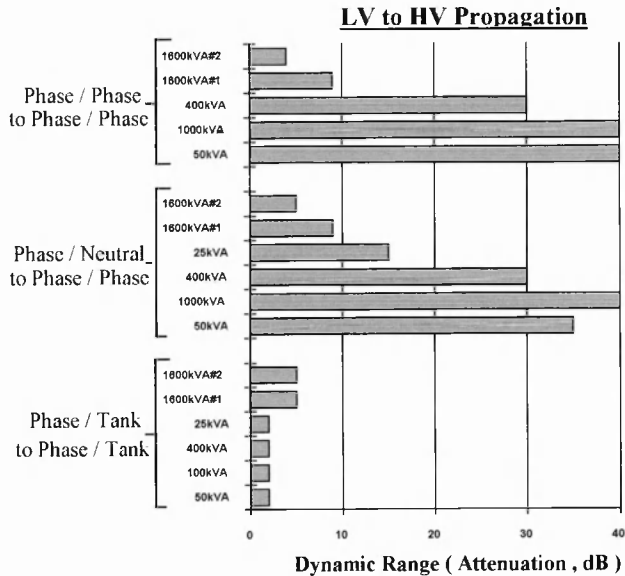

Fig 5.5.18b : Transformer Dynamic Range ( LV to HV , unenergised ) .

Of the signalling modes listed in table 5.5.3 , and illustrated in fig 5.5.18 , the most striking result is that of the phase / tank to phase / tank transmissions . In this mode a very small dynamic range exists , indicating a very flat propagation profile . The mean value of attenuation , in this mode , is consistently less than the 40 dB limit derived in section 5.5.2 . This characteristic is reflected in figure 5.5.12 of section 5.5.1.2 , where the through signalling pass bands extend from 1kHz through to 300kHz . It could therefore be concluded that the through transformer signalling characteristic , in phase / tank signalling mode , is governed by a flatter more predictable response than its phase / phase and phase / neutral counterparts .

These findings do not rule out the use of phase / neutral or phase / phase modes for PLC propagation . However , the characteristics of these modes reveal a more 'peaky' dynamic response . A total dynamic range of 70 dB , resulting from 'peaks' of +10 dB and 'troughs' of -60 dB , is shown in the summary in table 5.5.3 . Of course these peaks and troughs are extremes , and smaller deviations around a central mean value are more

common . Nevertheless , these extremes must be taken into account , as a communication system must be designed around 'worst case' conditions . This is the case in figures 5.5.13 and 5.5.14 of section 5.5.1.2 . Here , the 'peaky' nature of the 50 kVA , 1000 kVA and 400 kVA transformers results in the appearance of passband 'windows' at various points along the frequency spectrum . This factor obviously lays down boundaries within which a communication system must operate . These conditions will be discussed in section in the final chapter .

c) High pass and Low pass filter action .

Another characteristic of the transformers frequency responses which deserves a mention is that of the high and low pass filter action . With reference to figures 5.5.7 and 5.5.11 of section 5.5.1.2 , and the composite attenuation plots of appendix B , a 'pattern' emerges in the HV to LV and LV to HV responses . In all responses of all transformers in phase / neutral and phase / phase modes , all HV to LV characteristics exhibited a high pass filter response whilst all LV to HV characteristics exhibited a low pass filter response . Furthermore , the low pass characteristic , associated with LV to HV transmissions , produced a certain degree of signal voltage gain at frequencies  $\approx 10\text{kHz}$  . This action seems to be caused by the 'step up' nature of the transformer , which approaches the turns ratio (  $\approx 45:1$  ) at the 50Hz power frequency .

### Summary

Although the findings presented in this section reveal some important factors regarding through transformer signalling characteristics , they remain reflective of the transformer in its isolated , unenergised state . In order to predict , and analyse , the transformers behaviour under more 'real' conditions it remains necessary to conduct a program of experimental work whilst the transformer is in its powered up state . This will not only reveal the effects of core and winding energisation , but also those of connecting the transformer to the supply network , thus introducing the effects of network noise and impedance . This experimental program is now described in section 5.5.1.4.

### 5.5.1.4 Experimental Work Two: Energised Passbands

Section 5.5.1.2 was concerned with the transformers frequency response , and through signalling pass bands , in its isolated and unenergised state . However , in order to fully understand the transformers effect on PLC signals , the frequency response of the transformer must be examined in its energised ( powered up ) state . In order to obtain the frequency response of the energised transformer , the set up of fig 5.5.19 was utilised .

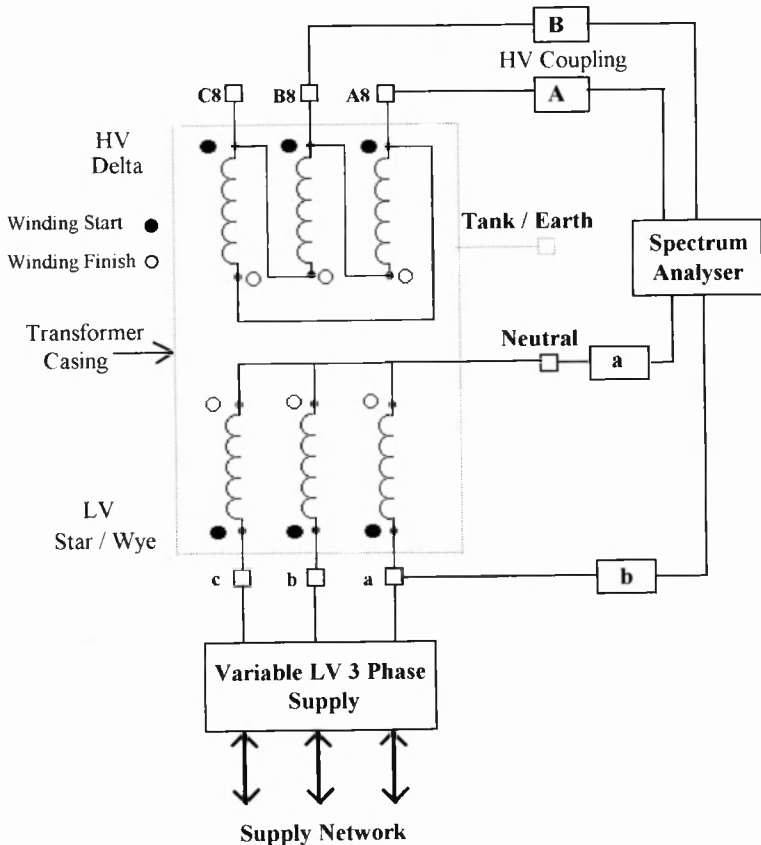
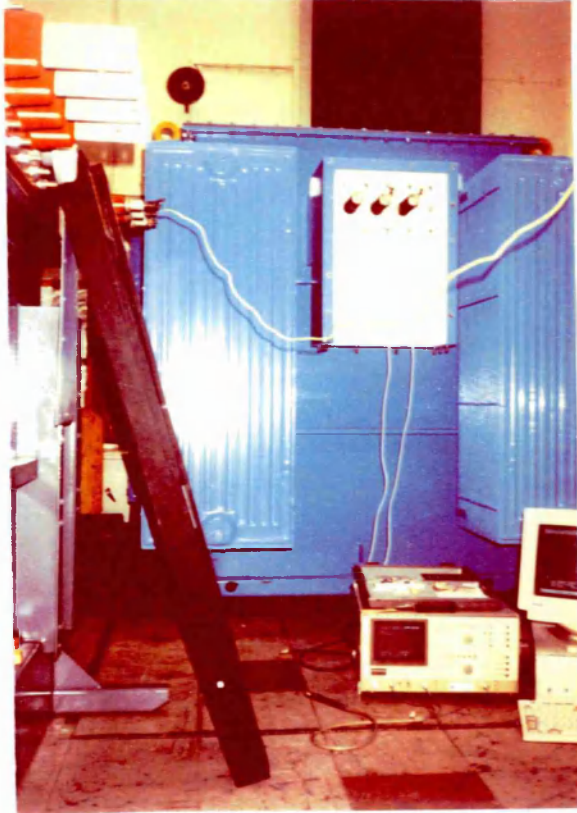

Fig 5.5.19 : Energised Test set up .

With the LV star winding of the transformer connected to a variable LV supply , the magnitude of the LV supply was slowly increased from 0V to the transformers normal

LV operating voltage of 415V . At this stage the transformers HV delta winding is energised at its normal operating voltage of 11kV . The spectrum analyser is connected via the respective HV and LV coupling circuits described in section 5.4 . A pictorial view of this experimental set up , performed at GEC Alstom , is shown in picture 5.5.1 .



Picture 5.5.1: Experimental set up , GEC Alstom , Stafford .

By using the spectrum analyser to frequency sweep the transformer , in much the same way as in section 5.2.1 and 5.5.1.2 , the transformers energised frequency characteristics were obtained . This experimental procedure was performed on all the transformers in all the signalling modes listed in table 5.5.2 . A cross section of these



frequency characteristics , together with their corresponding transposed frequency / attenuation plots , is presented in appendix C .

The analytical approach adopted in section 5.5.1.2 is then applied to the energised frequency characteristics . From this analysis , composite plots of transformer pass bands are presented in figures 5.5.20 , 5.5.21 and 5.5.22 for phase / tank , phase / neutral and phase / phase signalling modes respectively .

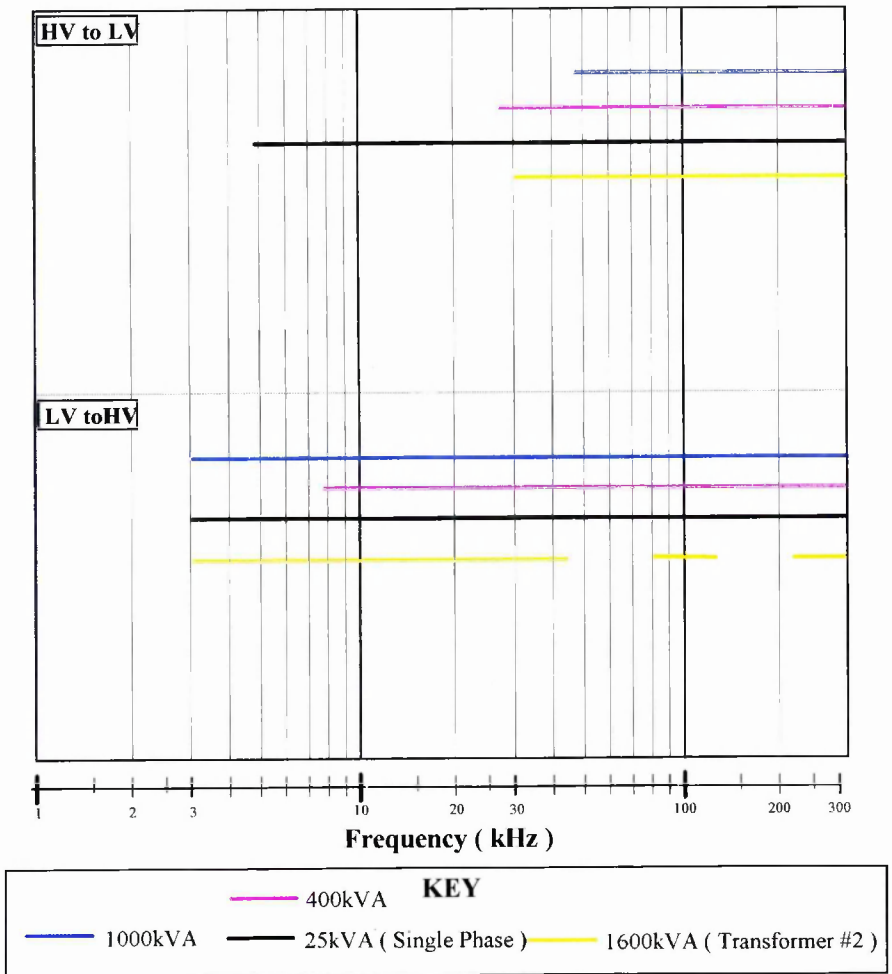

Fig 5.5.20 : Energised Phase / Tank to Phase / Tank , Pass bands .

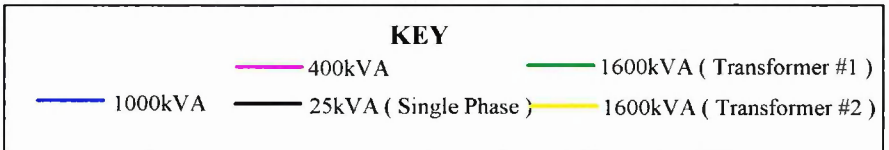
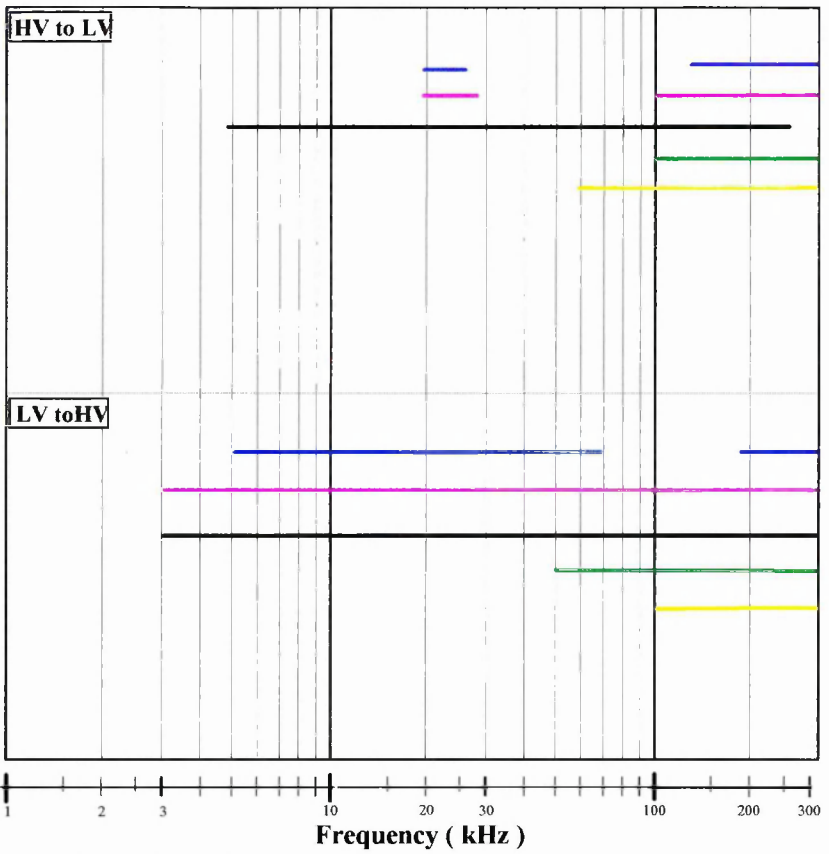

Fig 5.5.21 : Energised Phase / Phase to Phase / Neutral , Pass bands .

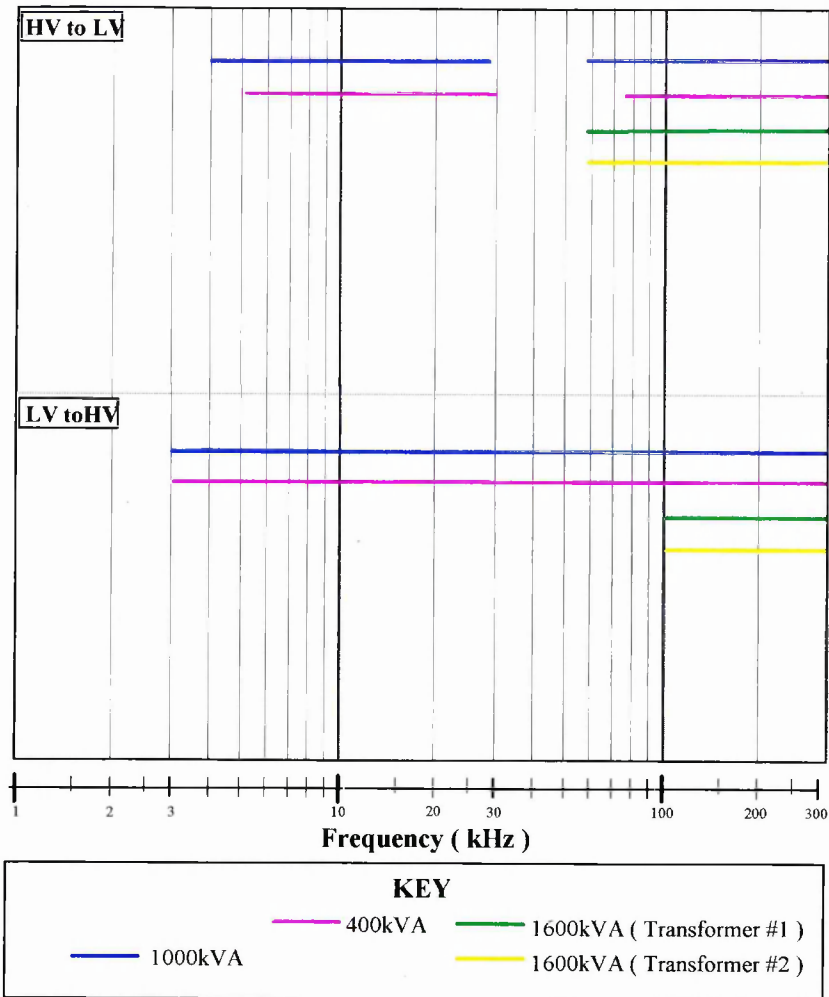

Fig 5.5.22 : Energised Phase / Phase to Phase / Phase , Pass bands .

### 5.5.1.5 Experimental Work Two - Findings

The results presented in section 5.5.1.4 , together with the plots shown in appendix C , give rise to the following findings .

a) Three phase Transformer Symmetry : Relationship between different configurations within the same signalling mode .

i) Phase / Neutral and Phase / Phase Signalling Modes .

With the transformers in their energised state , the relationship between signalling configurations in phase / neutral and phase / phase modes follows that of their unenergised counterparts , observed in section 5.5.1.3 . In other words , with the transformer powered up , certain combinations of phase connections , within a signalling mode , give rise to more favourable propagation characteristics whilst some present higher levels of attenuation . Because of this similar 'pattern' found in these 'live' characteristics it is implied that the most favourable and unfavourable configuration for signal propagation is predictable in nature . This finding holds true for phase / neutral and phase / phase signalling modes .

b) Frequency Characteristics : Dynamic Range .

As in the case of the unenergised frequency characteristics , a summary of the energised transformers dynamic range of attenuation levels is presented in table 5.5.4 and fig 5.5.23a ( HV to LV propagation ) and fig 5.5.23b ( LV to HV propagation ) . The findings of this investigation are as follows .

◆ Phase / Tank Signalling

The most striking characteristic in this signalling mode is that the response is no longer flat , as it was when the transformer was unenergised . However , over the frequency range of interest ( 20kHz to 150kHz ) , the frequency characteristics of signalling configurations were strikingly similar ( with respect to each transformer ) .

◆ Phase / Neutral and Phase / Phase Signalling

Although more 'peaky' than phase / tank mode , the peaks and troughs in the characteristics seem to be less sharp and severe than the unenergised characteristics . This smoother propagation profile does not exclude the existence of frequency 'notches' which present high levels of attenuation . Table 5.5.4 reveals at certain frequencies attenuation may be as high as 60 dB , which falls outside the 40 dB limit derived in section 5.5.1.1 .

| <b>Transformer</b> | <b>Signalling Mode</b> | <b>Peak ( dB )</b> | <b>Trough ( dB )</b> | <b>Dynamic Range</b> |
|--------------------|------------------------|--------------------|----------------------|----------------------|
| <b>1000 kVA</b>    | Phase/Tank . HV to LV  | -15                | -50                  | <b>35 dB</b>         |
| <b>1000 kVA</b>    | Phase/Tank . LV to HV  | 0                  | -35                  | <b>35 dB</b>         |
| <b>1000 kVA</b>    | Phase/Neut . HV to LV  | -25                | -50                  | <b>25 dB</b>         |
| <b>1000 kVA</b>    | Phase/Neut . LV to HV  | 0                  | -50                  | <b>50 dB</b>         |
| <b>1000 kVA</b>    | Phase/Phase . HV to LV | -20                | -50                  | <b>30 dB</b>         |
| <b>1000 kVA</b>    | Phase/Phase . LV to HV | 0                  | -40                  | <b>40 dB</b>         |
| <b>400 kVA</b>     | Phase/Tank . HV to LV  | -10                | -50                  | <b>40 dB</b>         |
| <b>400 kVA</b>     | Phase/Tank . LV to HV  | 0                  | -30                  | <b>30 dB</b>         |
| <b>400 kVA</b>     | Phase/Neut . HV to LV  | -30                | -50                  | <b>20 dB</b>         |
| <b>400 kVA</b>     | Phase/Neut . LV to HV  | -10                | -40                  | <b>30 dB</b>         |
| <b>400 kVA</b>     | Phase/Phase . HV to LV | -20                | -50                  | <b>30 dB</b>         |
| <b>400 kVA</b>     | Phase/Phase . LV to HV | -10                | -40                  | <b>30 dB</b>         |
| <b>25 kVA</b>      | Phase/Tank . HV to LV  | -20                | -50                  | <b>20 dB</b>         |
| <b>25 kVA</b>      | Phase/Tank . LV to HV  | 0                  | -30                  | <b>30 dB</b>         |
| <b>25 kVA</b>      | Phase/Neut . HV to LV  | -20                | -40                  | <b>20 dB</b>         |
| <b>25 kVA</b>      | Phase/Neut . LV to HV  | 0                  | -30                  | <b>30 dB</b>         |
| <b>1600 kVA #1</b> | Phase/Tank . HV to LV  | 0                  | -50                  | <b>50 dB</b>         |
| <b>1600 kVA #1</b> | Phase/Tank . LV to HV  | -20                | -50                  | <b>30 dB</b>         |
| <b>1600 kVA #1</b> | Phase/Neut . HV to LV  | -20                | -60                  | <b>40 dB</b>         |
| <b>1600 kVA #1</b> | Phase/Neut . LV to HV  | -30                | -60                  | <b>30 dB</b>         |

|                    |                       |     |     |              |
|--------------------|-----------------------|-----|-----|--------------|
| <b>1600 kVA #1</b> | Phase/Phase ,HV to LV | -10 | -60 | <b>50 dB</b> |
| <b>1600 kVA #1</b> | Phase/Phase ,LV to HV | -30 | -60 | <b>30 dB</b> |
| <b>1600 kVA #2</b> | Phase/Neut ,HV to LV  | -15 | -50 | <b>35 dB</b> |
| <b>1600 kVA #2</b> | Phase/Neut ,LV to HV  | -20 | -50 | <b>30 dB</b> |
| <b>1600 kVA #2</b> | Phase/Phase ,HV to LV | -20 | -50 | <b>30 dB</b> |
| <b>1600 kVA #2</b> | Phase/Phase ,LV to HV | -20 | -60 | <b>30 dB</b> |

Table 5.5.4 : Transformer Dynamic Range ( Energised ) .

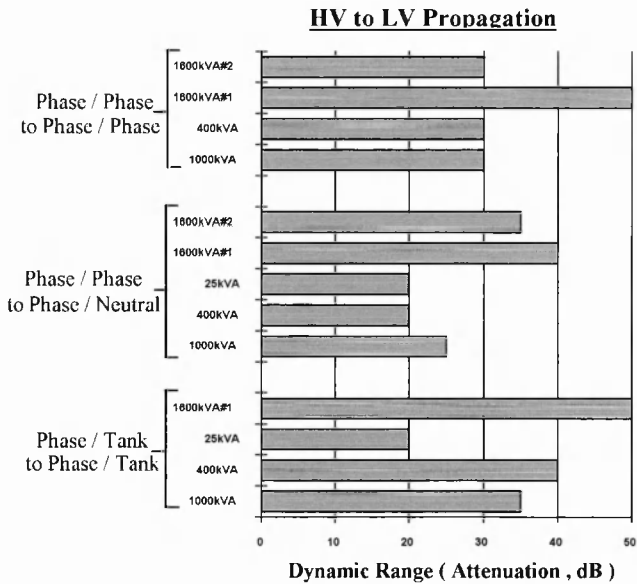

Fig 5.5.24a : Transformer Dynamic Range ( HV to LV , Energised ) .

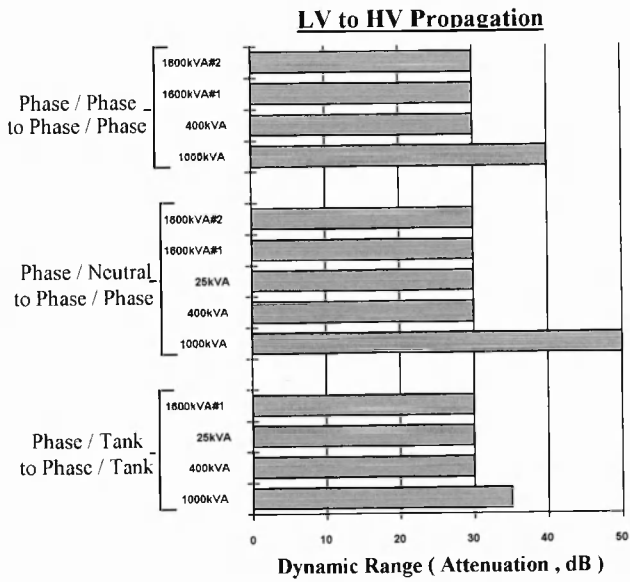

Fig 5.5.24b : Transformer Dynamic Range ( LV to HV , Energised )

c) High and low pass filter action .

In referring to the composite attenuation plots in appendix C , the presence of high pass filter action in HV to LV transmission and low pass filter action in LV to HV transmissions , in all signalling modes and transformers is evident . Although this action is not as pronounced as in the unenergised state , due to the inclusion of HV and LV coupling circuits , its effect may well bear consideration when selecting appropriate signalling bands for HV to LV and LV to HV transmissions . This effect is summarised in the following fig 5.5.25 .

d) Pass Bands .

With reference to figures 5.5.20 , 5.5.21 and 5.5.22 of section 5.5.1.3 , a graphical representation of the transformers signalling pass bands is presented . The coloured bands represent the frequency range which presents no more than 40 dB of attenuation . The following observations are made from these results .

- ◆ LV to HV transmissions have more favourable propagation characteristics than HV to LV signalling . This may partly be due to the 'step up' nature of the transformer .
  
- ◆ The more 'peaky' nature of phase / neutral and phase / phase modes is reflected by the presence of narrower pass bands . Hence , phase / tank mode signalling posses more favourable propagation characteristics in the form of a wider bandwidth which is available for through transformer signalling .
  
- ◆ Although phase / neutral and phase / phase modes exhibit pass bands in the tens of kHz range , the pass band 'windows' common to all transformers studied , occur at frequencies greater than 100kHz .
  
- ◆ With the propagation characteristics favouring signal pass bands at around and above the 100kHz region it would seem justifiable to use signal carrier frequencies in this frequency range .



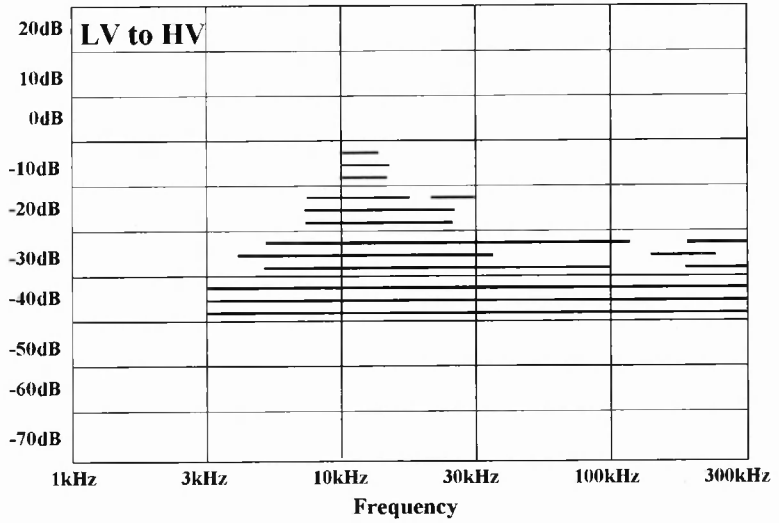
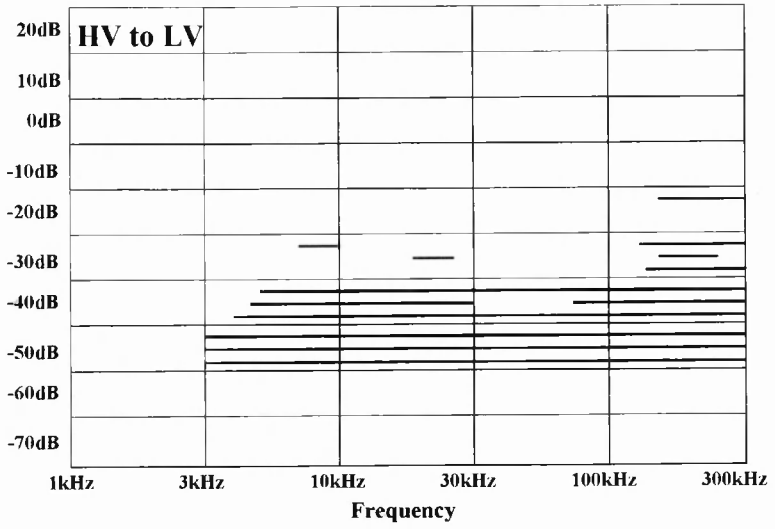

Fig 5.5.25 : High and Low pass filter action .

e) Network Impedance Effects .

In comparing the unenergised and energised passbands of section 5.5.1.2 and 5.5.1.4 respectively , it is clear that when the transformers are energised , the available signalling bandwidth decreases . This observation could be attributed to the energised core and windings reducing signal coupling from HV winding to LV winding ( and vice versa ) , and or , the low impedance loading effect of the power supply connected to the LV terminals .

In order to determine which of these factors influenced the propagation characteristics the following investigation was devised . Using the set up of fig 5.5.19 , section 5.5.1.4 , a frequency sweep was made of the 1000 kVA transformer from the phases A8 / B8 to LV phases a / b . With the transformer energised to its full rated voltage the frequency response of fig 5.5.26 resulted .

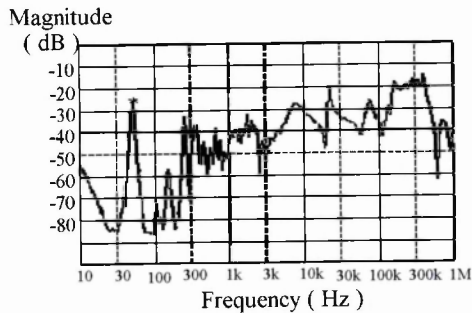

Fig 5.5.26 : Phases A8 / B8 to Phases a / b ( Energised )

With the LV supply now reduced to 0V , yet still remaining connected , another frequency sweep was made . This response is shown in fig 5.5.27 .

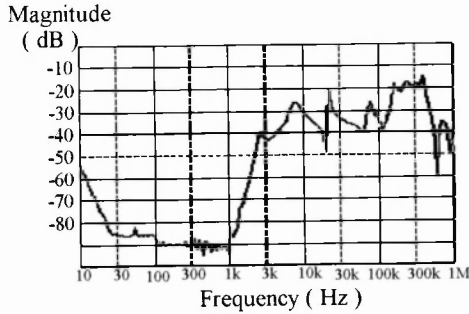

Fig 5.5.27 : Phases A8 / B8 to Phases a / b ( Unenergised )

The similarity between fig 5.5.26 and 5.5.27 is clearly evident , in fact by superimposing these two plots in fig 5.5.28 , virtually identical profiles exist at frequencies  $> \approx 3\text{kHz}$  .

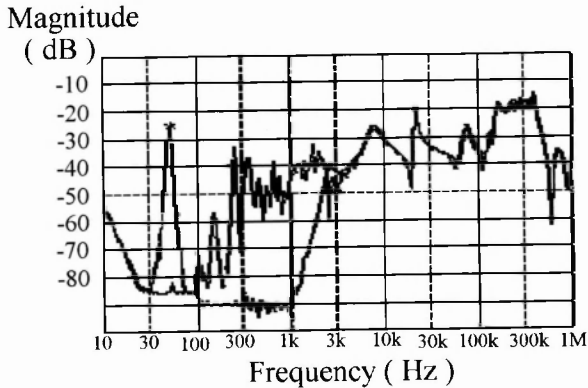

Fig 5.5.28 : Composite plot of Energised and Unenergised response .

These results suggest that energising the transformers core and windings has little effect on its frequency response at frequencies higher than around 3kHz . Moreover , it seems to be the loading effect of the LV supply , and LV network , which influences through transformer signal propagation .

This revelation highlights the contributing factor of LV network impedance when injecting a signal at the transformers terminals . The particularly low levels of impedance

typical of LV networks ( section 3.6 , chapter 3 ) may be orders of magnitude lower than the transformers input impedance . These factors will reduce signals in level before they have a chance to propagate through the transformer . This topic of analysis merits further research work .

### **5.5.2 Non Coherent and Coherent Wideband**

The constraints applied to narrowband PLC systems are responsible for restricting signal bandwidths to those described in section 5.5.1 . In order to increase system robustness , in the presence of propagation troughs and noise , power line carrier signalling systems have seen the emergence of wideband modulation techniques . These systems may be grouped under two categories , namely , non coherent and coherent wideband . Each of these two variants are effected quite differently by the transformers through signalling frequency characteristics . These two techniques will now be examined in greater detail for their ability to propagate through the transformer . This may be accomplished by analysing the transformer characteristics obtained in sections 5.5.1.2 and 5.5.1.4 in conjunction with existing wideband systems . From this analysis a different set of signalling bands will emerge .

#### **5.5.2.1 Non Coherent Wideband**

In this category two of the spread spectrum variants exist , namely , Frequency Hopping and Chirp . As in the case of non coherent narrowband , phase changes in the communications channel do not impair signal detection . In these terms , non coherent wideband does suffer some of the drawbacks of narrowband systems , but its spread frequency nature ensures much better performance under poor signal to noise ratios .

Note: Most frequency hopping systems employ envelope detection to overcome the phase shifts encountered between 'hops' . Although coherent systems do exist they remain unsuitable for use as a PLC . Hence , non-coherent frequency hopping will only be considered .

◆ Frequency Hopping Systems:

The ability of frequency hopping systems to cope with severe attenuation is similar to FSK systems . After all , frequency hopping systems are basically n-array FSK with more channels , using a code sequence for channel selection . This implies that in a frequency hopping system , at any instant in time , the system may be analysed as a single carrier at a certain frequency , much the same as FSK . From this reasoning it may be deemed necessary that the receiver will always require a positive signal to noise ratio at its input . This characteristic of frequency hopping spread spectrum distinguishes it from Chirp and direct sequence spread spectrum . Fig 5.5.29 illustrates the effect which the transformers propagation characteristics have on a frequency hopping system , by displaying an expanded plot of the characteristics between 10kHz and 100kHz . Although the characteristics illustrated in fig 5.5.29 are of an unenergised transformer , the profile of the plot is typical of results obtained from energised responses .

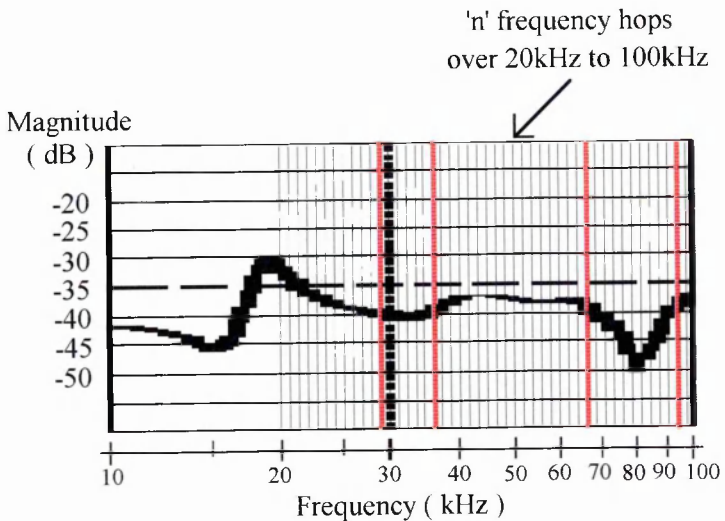

Fig 5.5.29 : Frequency Hopping System .

If a frequency hopping system is considered , which uses 'n' frequency hops over the frequency range 20kHz to 100kHz , transmissions will be impaired in the following manner . The carrier hops which fall within the boundaries highlighted (  $\approx 30$ kHz to

35kHz ) and (  $\approx$  65kHz to 90kHz ) are attenuated in excess of 40dB , they therefore remain undetected at receiver input . This will modify the expected error rate in the following manner .

The probability of error may be expressed as a function of the ratio of channels ( hops ) which are jammed ( J ) to the number of frequency channels ( hops ) available ( N ).

$$\therefore \text{Errors } (p) = \frac{J}{N}$$

From fig 5.5.29 the reduction in available bandwidth due to propagation troughs has the direct result of channel losses . The number of available channels ( N ) will be a function of total bandwidth used , whilst the number of channels jammed will be a function of the bandwidth attenuated in excess of 40dB .

$$\therefore p = \frac{(35\text{kHz} - 30\text{kHz}) + (90\text{kHz} - 65\text{kHz})}{80\text{kHz}} \approx 38\%$$

In other words 62% of data transmitted will be detected at the receiver . For example , with a data rate of 1kbps , using one hop ( channel ) per data bit , a 'net' data rate of 620bps will be interpreted by the receiver . This analytical approach may be extended further .

With reference to figures 5.5.20 , 5.5.21 , 5.5.22 of section 5.5.1.4 , the percentage of usable bandwidth ( in the form of propagation windows of different transformers , over the range 10kHz to 150kHz ) , is tabulated in table 5.5.5 . The usable bandwidth of each signalling mode in each direction is expressed as a percentage range which covers the 'worst' transformer and the 'best' transformer .

| <b>Signalling Mode /<br/>Direction</b> | <b>% Usable Bandwidth<br/>( Worst Case )</b> | <b>% Usable Bandwidth<br/>( Best Case )</b> |
|--|--|---|
| <b>Phase / Tank : HV to LV</b>         | 75%  | 100%  |
| <b>Phase / Tank : LV to HV</b>         | 50%  | 100%  |
| <b>Phase/ Neutral:HV to LV</b>         | 32%  | 100%  |
| <b>Phase/ Neutral:LV to HV</b>         | 36%  | 100%  |
| <b>Phase / Phase : HV to LV</b>        | 64%  | 79%   |
| <b>Phase / Phase : LV to HV</b>        | 36%  | 100%  |

Table 5.5.5: Usable Transformer Bandwidth .

The results of table 5.5.5 indicate that although some transformers will allow all frequency channels ( hops ) to pass unjammed  $\left( \frac{J}{N} \Rightarrow 0 \right)$ , the likelihood of unacceptable channel jamming is relatively high  $\left( \frac{J}{N} > 0.5 \right)$ . The high percentage of channel jamming will lead to excessive error rates , necessitating the inclusion of sophisticated error correction schemes .

An approach of increasing or decreasing the number of frequency channels ( hops) over the range of operation will not improve matters , as the ratio of jammed channels to total channels will remain constant . A reduction in error rate may be achieved by increasing the number of hops per bit of information . However this approach requires a considerable reduction in data rate , when used to overcome wide attenuation troughs in propagation . Moreover , in taking this approach to an extreme the systems characteristics become similar to Chirp spread spectrum , in the sense that a large bandwidth is covered just to represent one bit of information .

Having analysed the operation of frequency hopping spread spectrum in the presence of the transformers propagation characteristics the following conclusions may be drawn .

Although more inefficient in terms of bandwidth occupation , than narrowband modulation schemes , its frequency hopping nature will ensure that 'windows' in propagation are 'found' . In the case of narrowband systems , carrier frequencies must be carefully chosen to coincide with a propagation window which is common to all transformers .

In order for frequency hopping systems to overcome the problem of high error rates , due to unusable portions of bandwidth , an intelligent / adaptive form of channel hopping may be employed . By adopting this approach , frequency ranges of high attenuation may be noted and avoided , thus reducing the number of jammed channels and corresponding error rate . Obviously such systems require development before the benefits of this approach may be reaped . Until then it would perhaps seem that frequency hopping remains an uneconomical method of through transformer signalling .

◆ Chirp Systems .

In Chirp systems ( section 4.5.6 , chapter 4 ) the frequency swept carriers envelope , at the receiver , is detected over its band of operation and 're assembled' into a meaningful bit of information . This is accomplished in the following manner .

The receiver contains a matched 'chirp' filter ( dispersive filter ) which is basically a storage and summing device that accumulates the energy over the sweep period , assembles it , and releases it in one coherent burst . The dispersive filter provides a compressed pulse of the form shown in fig 5.5.30 .

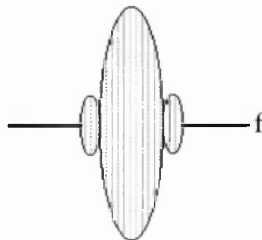

Fig 5.5.30: Compressed output of dispersive filter .



By compressing the energy over a wide bandwidth ( $\Delta f$ ) an improvement in output signal to noise ratio is obtained . A parameter of importance with Chirp is the 'compression ratio' (  $D$  ) provided by the receivers dispersive filter . This parameter may be quantified as:

$$D = \Delta f * \Delta T$$

i.e. The compression ratio is the product of sweep bandwidth and sweep time .

Compression ratio also gives rise to the systems Jamming Margin (  $M_j$  ) .

### **Jamming Margin:**

In order to define the systems jamming margin the system process gain must firstly be reviewed . Process gain is the ratio of output to input signal to noise ratios brought about by the 'spreading' and 'de spreading' action of spread spectrum modulation .

With reference to Chirp systems , process gain is a function of the systems compression ratio (  $D$  ) .

$$\text{Process Gain} = ( G_p ) = 10\log_{10} \Delta f * \Delta T \quad \mathbf{5.1}$$

Although this equation provides a measure of the difference between input and output SNR's , it does not take into account system losses . The term 'Jamming Margin' accounts for system losses and provides a level , expressed in dB's , which the signal may exist below the noise level , yet still remain detectable at the receiver .

Jamming Margin (  $M_j$  ) may be quantified by the following equation,

$$\text{Jamming Margin} = G_p - \left[ L_{\text{sys}} + \left( \frac{S}{N} \right)_{\text{OUT}} \right] = M_j \quad \mathbf{5.2}$$

Where ,  $L_{\text{sys}}$  = System Implementation Losses  
and  $\left( \frac{S}{N} \right)_{\text{OUT}}$  = SNR at information output

In the previous equation the quantities  $L_{sys}$  and  $\left(\frac{S}{N}\right)_{OUT}$  may be conservatively estimated .

Typical system losses (  $L_{sys}$  ) are typically in the range 0 dB to 3 dB [72] , depending on the demodulation process . A 'worst case' value of 3 dB will therefore be assumed .

The  $\left(\frac{S}{N}\right)_{OUT}$  , expressed in dB's is the level which the signal must appear , above the noise , after the receivers detection and compression process . Clearly this must be a positive value in order that the signal may be recognised . For this quantity a range of typical values is 0 dB to 15 dB , depending upon the nature of information transmitted and the systems components . With reference to Dixon [72] , data transmission systems require around 15 dB of output signal to noise ratio . Therefore , for the purpose of this analysis it may be deemed necessary that the output signal must be 15 dB above the background noise .

$$\text{Therefore } \left(\frac{S}{N}\right)_{OUT} = 15 \text{ dB}$$

$$\therefore M_j = G_p - [3\text{dB} + 15\text{dB}]$$

$$M_j = G_p - 18\text{dB}$$

### **Determining Process Gain:**

From the experimental results of section 5.5.1.5 the greatest magnitude of attenuation presented by the transformer in its energised state , in all modes of signalling , is 60 dB . Because the maximum level of signal injection has previously been stated as 5v , an attenuation of 60 dB will give rise to a signal level of ,

$$5\text{v} - 60 \text{ dB} = \frac{5\text{V}}{1000} = 5\text{mV}$$

The Jamming Margin now represents the degree to which the signal may be detected below the background mains noise . The level of background noise has previously been stated as 10 mV pk to pk . Hence the signal will 'appear below the background noise by 6 dB . The required jamming margin is therefore 6 dB .

Now ,  $M_j = G_p - 18 \text{ dB}$   
 $6 \text{ dB} = G_p - 18 \text{ dB}$   
 $G_p = 6 \text{ dB} + 18 \text{ dB} = \mathbf{24 \text{ dB}}$

Although it may seem excessive , this level of process gain will allow the chirp system to reliably perform with levels of attenuation of up to 60 dB throughout its band of operation (  $\Delta f$  ) . Of course , equation 5.1 implies that a trade off must be met , regarding bandwidth and sweep time , if this goal is to be achieved . The forthcoming section ( section 5.5.2.2 ) examines these trade-offs by analysing a commercially available Chirp system .

### 5.5.2.2 Experimental Work Three - Chirp Systems

In order to asses chirps ability to cope with the dynamic ranges encountered in through transformer propagation , the characteristics of a commercially available chirp system was analysed . The chirp system under investigation is the Intellon Spread Spectrum Modem , described in detail in reference [50] , the following account summarises its operation .

The Intellon system utilises a frequency swept carrier in the range 20kHz to 80kHz with a  $500\mu$  second sweep time , thus giving a data rate of  $\frac{1}{500\mu \text{ secs}} \equiv 2000 \text{ bps}$

If the carrier sweep time of  $500\mu$  seconds is referred to as the sequence length , a typical sequence may appear as follows ,

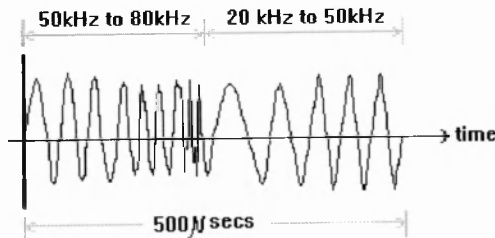

Fig 5.5.31 Intellon Swept Carrier .

The sequence of fig 5.5.31 consists of sweeping the carrier from 50kHz to 80kHz then from 20kHz to 50kHz . Fig 5.5.32 illustrates the frequency sweeping carrier wave typical of chirp spread spectrum . Its sequence length was measured at around  $500\mu$  seconds over the range 20kHz to 80kHz . The amplitude ranged from a maximum of  $\approx 5.2V$  pk to pk to a minimum of  $\approx 3.8V$  pk to pk .

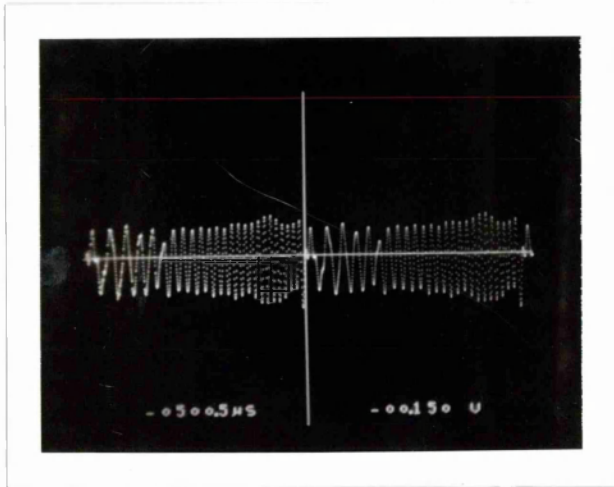

Fig 5.5.32 : Observation of Intellon Sequence .

The bandwidth and sweep time of the Intellon system produce the following process gain .

$$\begin{aligned}
 G_p &= 10 \log_{10} D T^* D f \\
 &= 10 \log_{10} (500 * 10^{-6}) (60 * 10^3) \\
 &= 10 \log_{10} 30 \\
 &= \mathbf{14.8 \text{ dB}}
 \end{aligned}$$

From equation 5.2 the following Jamming Margin is realised ,

$$\begin{aligned}
 M_j &= G_p - 18 \text{ dB} \\
 &= 14.8 \text{ dB} - 18 \text{ dB} \\
 \mathbf{M_j} &= \mathbf{-3.2 \text{ dB}}
 \end{aligned}$$

This negative Jamming Margin implies that the signal , at receiver input , must be at least 3.2 dB above background noise level .

$$\begin{aligned} \therefore 10\text{mV} + 3.2\text{dB} &= 10\text{mV} * 1.44 \\ &= 14.4\text{mV} \end{aligned}$$

This implies maximum permissible attenuation of a 5V pk to pk injected signal of ;

$$\begin{aligned} \text{Attenuation (dB)} &= 20 \log_{10} \frac{5}{14.4 * 10^{-3}} \\ &= \mathbf{50.8 \text{ dB}} \end{aligned}$$

In other words the Intellon system has the ability to reliably perform across a bandwidth of 60kHz , with up to  $\approx 50$  dB of attenuation throughout this band , whilst sustaining a 2000 bps data rate .

In order to investigate the effects of through transformer signalling the Intellon system was connected as follows in fig 5.5.33 .

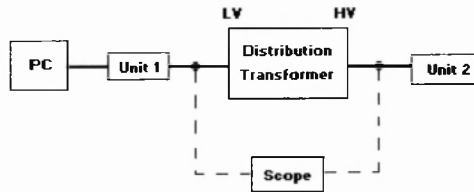

Fig 5.5.33 : Intellon System Set up .

The Intellon units were configured to transmit and receive in a half duplex form of communication . The effects of transformer action on signal propagation could therefore be investigated .

With reference to fig 5.5.33 , two signals may be considered .

- i. The received carrier signal from unit 2 which has passed through the transformer from the HV side to the LV side .
- ii. The received carrier signal from unit 1 which has passed through the transformer from the LV side to the HV side .

The results may be tabulated as follows :

| Signalling Mode                  | Received Carrier Attenuation | Received Carrier Attenuation |
|----------------------------------|------------------------------|------------------------------|
|                                  | HV to LV                     | LV to HV                     |
| Phase / Phase to Phase / Tank    | <b>-22 dB to -28 dB</b>      | <b>-19 dB to -26.5 dB</b>    |
| Phase / Phase to Phase / Neutral | <b>-28 dB to -32 dB</b>      | <b>-13 dB to -30 dB</b>      |
| Phase / Phase to Phase / Phase   | <b>-27 dB to -33 dB</b>      | <b>-17 dB to -35.5 dB</b>    |

Table 5.5.6 : Chirp Carrier Attenuation .

Fig 5.5.34 illustrates a chirp sequence which has passed through the transformer from phases a / n to phases A8 / B8 ( LV to HV ) . The corresponding transformer characteristics in this mode and connection are shown in fig 5.5.35 ( Expanded plot ) .

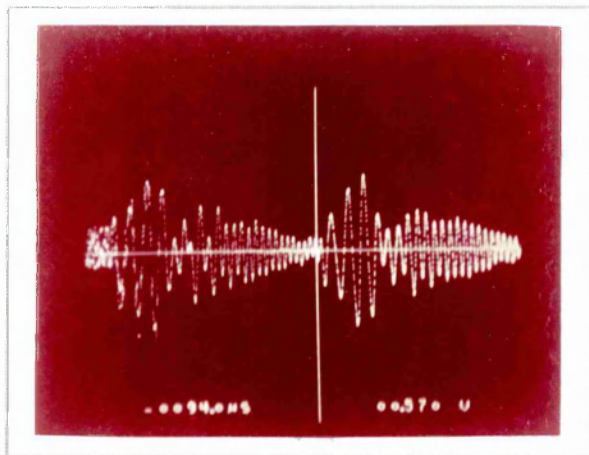

Fig 5.5.34 : Chirp Sequence ( passed through transformer )

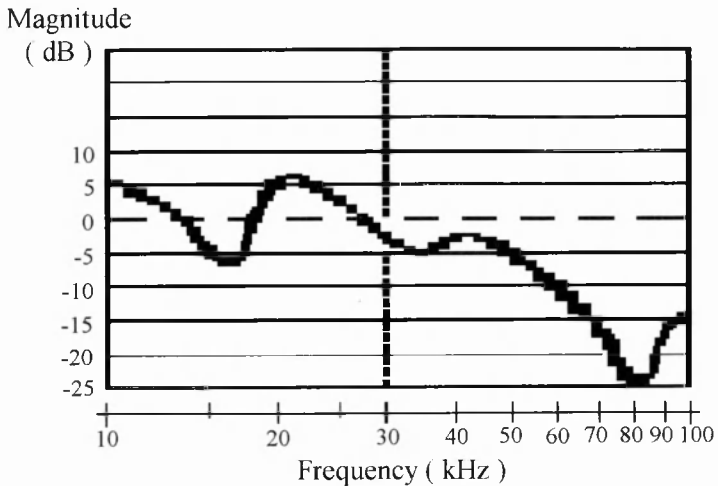

Fig 5.5.35 : Expanded plot ( phases a / n to phases A8 / B8 ) .

The effect of troughs in propagation at  $\approx 32$  kHz and  $\approx 80$  kHz are clearly seen on the chirp sequence, by its attenuation at the respective frequencies. On the contrary, the effects of peaks in the characteristics are visible at  $\approx 21$  kHz.

#### Data Transmission Results:

Data transmission yielded the following results file;

FILE: lint4.ext  
 phase/phase to phase/neutral 40% dead

#### INTELLON Spread Spectrum Carrier -- Network Summary

START: Thu Mar 30 11:02:28 1995  
 END: Thu Mar 30 11:03:28 1995  
 Total Transmitted Packets = 444  
 Total Received Packets = 444  
 DLL Type: MULTI\_ACK\_DATA  
 House Code = 1  
 Total Offered Loading is 40.00%

| ***** Unit #1 *****        | ***** Unit #2 *****        |
|----------------------------|----------------------------|
| Participation: Transceiver | Participation: Transceiver |
| Destination Unit: 2        | Destination Unit: 1        |
| Packet Data: Random        | Packet Data: Random        |
| Packet Length: 20          | Packet Length: 20          |
| Channel Loading: 20.00%    | Channel Loading: 20.00%    |
| #Tx= 222                   | #Tx= 222                   |
| #Rx= 222                   | #Rx= 222                   |
| %Tx= 100.00%               | %Tx= 100.00%               |
| AvgTx= 1.00                | AvgTx= 1.00                |

One important parameter of these results is the average transmission rate (AvgTx). This figure represents the average transmit attempts to successfully achieve closed loop communications ( i.e. to receive an acknowledge from the other participating unit ) . The previous results reveal AvgTx = 1.00 , in other words each message packet was successfully transmitted and received without the need for re transmission . This suggests that the Intellon system performed perfectly well in the presence of the attenuation characteristics of fig 5.5.35 . These results are not surprising since previous calculations show an ability of the Intellon system to operate with up to  $\approx 50$ dBof attenuation .

### **Attenuation Versus Bandwidth & Data Rate:**

An important characteristic of Chirp spread spectrum is its ability to trade bandwidth and sweep time ( data rate ) for the ability to function in the presence of greater levels of attenuation . Although the Intellon system is unable to cope with attenuation levels exceeding 50dB , throughout its band of operation , a reduction in data rate , or increase in bandwidth , will give the system the ability to contend with higher levels of attenuation .

These trade-offs give rise to maximum theoretical data rates achievable over an available bandwidth in the presence of varying degrees of attenuation . However , it must



be borne in mind that with respect to CENELEC standard 50065-1 , the maximum permissible bandwidth must not exceed 150kHz . Table 5.5.7 reflects these trade-offs .

| Attenuation | Required Process Gain | Channel Capacity | Channel Capacity | Channel Capacity | Channel Capacity |
|-------------|-----------------------|------------------|------------------|------------------|------------------|
|             |                       | BW=40kHz         | BW=80kHz         | BW=100kHz        | BW=150kHz        |
| 0 dB        | -36 dB                | = Shannon Limit  | = Shannon Limit  | = Shannon Limit  | = Shannon Limit  |
| 10 dB       | -26 dB                | = Shannon Limit  | = Shannon Limit  | = Shannon Limit  | = Shannon Limit  |
| 20 dB       | -16 dB                | = Shannon Limit  | = Shannon Limit  | = Shannon Limit  | = Shannon Limit  |
| 30 dB       | -6 dB                 | = Shannon Limit  | = Shannon Limit  | = Shannon Limit  | = Shannon Limit  |
| 40 dB       | 4 dB                  | 15.924 kbps      | 31.85 kbps       | 39.81 kbps       | 59.716 kbps      |
| 50 dB       | 14 dB                 | 1592 bps         | 3185 bps         | 3981 bps         | 5971 bps         |
| 60 dB       | 24 dB                 | 159 bps          | 318 bps          | 398 bps          | 597 bps          |
| 70 dB       | 34 dB                 | 16 bps           | 32 bps           | 40 bps           | 60 bps           |

Table 5.5.7: Attenuation versus Bandwidth & Data Rate .

The table shows that with attenuation levels less than 40dB the limit of channel capacity is that imposed by Shannons law .

i.e. Maximum channel capacity ( bps ) = 2\*Bandwidth .

To obtain a picture of the way attenuation level and available bandwidth effect attainable data rate , the data in table 5.5.7 may be represented graphically in fig 5.5.36 .

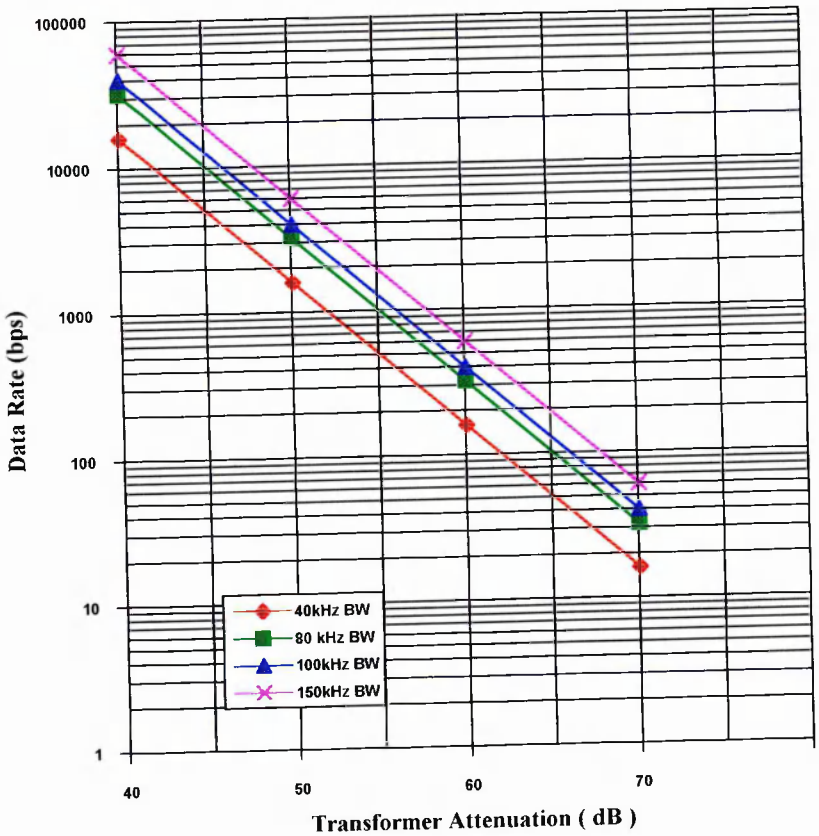

Fig 5.5.36: Attenuation versus Bandwidth & Data Rate .

The graph of fig 5.5.36 presents extreme limiting conditions . The attenuation levels displayed on the 'x' axis reflect the attenuation level present throughout the bandwidth of operation , which limits the data rate to its respective theoretical maximum .

### 5.5.2.3 Experimental Work Three - Findings .

Following the investigations of section 5.5.2.2 several conclusions may be drawn from the operation of Chirp systems .

- ◆ The Intellon system is theoretically capable of operating in a continuous band of attenuation of up to  $\approx 50\text{dB}$  .
- ◆ Results show that although troughs in the propagation characteristics may attenuate the carrier severely at certain frequencies , an intelligible signal may be detected and interpreted if the carrier traverses a 'window' in propagation .
- ◆ In sections 5.5.1.2 to 5.5.1.5 it was shown that a narrowband system must be designed in order that the carrier will fall into a propagation window which is common to different signalling configurations over a range of transformers . On the contrary , the swept carrier nature of the Chirp spread spectrum ensures the carrier will traverse these common 'windows' in propagation .
- ◆ Fig 5.5.36 shows Chirps ability to use a wider bandwidth to increase data rate , or alternatively reduce data rate in order to cope with more excessive levels of attenuation . However , the data rate may not be increased indefinitely ( by reducing the process gain to unrealistically low levels ) , as the channels maximum theoretical capacity will be reached .
- ◆ The previous statement highlights an important observation . It would seem that as attenuation levels reduce to around the 40dB level , the advantage which Chirp holds over narrowband systems declines , as it no longer remains necessary to sweep the carrier over a large bandwidth . Moreover , at these low levels of attenuation narrow band systems seem to operate quite adequately . The topic of which modulation scheme is most suitable for differing levels of attenuation will be discussed in chapter six .

In general the implications of these findings are that a chirp system could be expected to cope well in the presence of a 'peaky' , unpredictable propagation characteristic . The experimental set up of the Intellon system may be viewed in picture 5.5.2 ( following ) . Here a PC is shown to be sending data via the Intellon modem , through an energised

1600KVA transformer , sited at GEC Alsthom . The results of these further investigations appear encouragingly successful in coping with the severity's in attenuation.

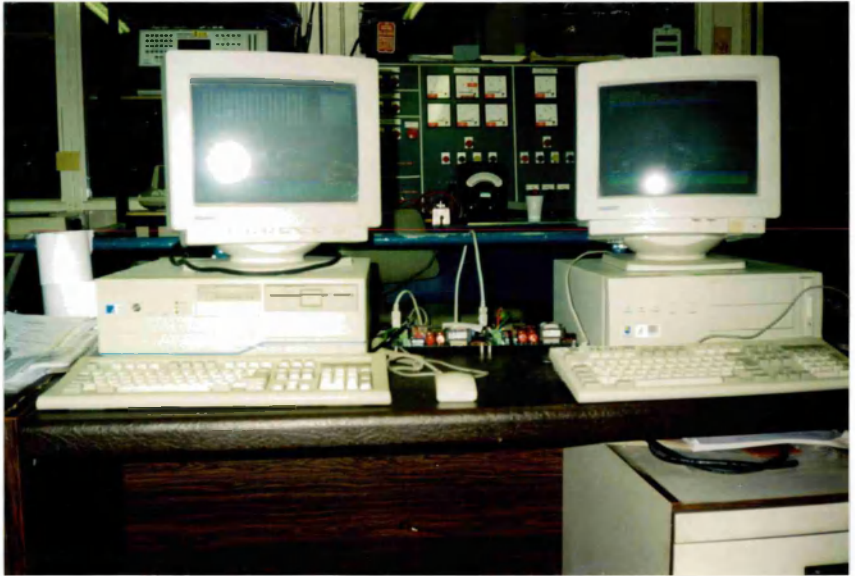

Picture 5.5.2: Intellon Modem tests , GEC Alsthom , Stafford .

The findings from these investigations suggest that chirp spread spectrum is a particularly robust modulation technique when used as a PLC . The drawback of this technique is evident from fig 5.5.31 , here a bandwidth of 60kHz is required to support a data rate of only 2000 bps .

#### **5.5.2.4 Coherent Wideband .**

As a PLC the most extensively used form of coherent wideband modulation is that of direct sequence spread spectrum . With reference to section 4.5.4 , chapter 4 , the following Direct Sequence system may therefore be realised :

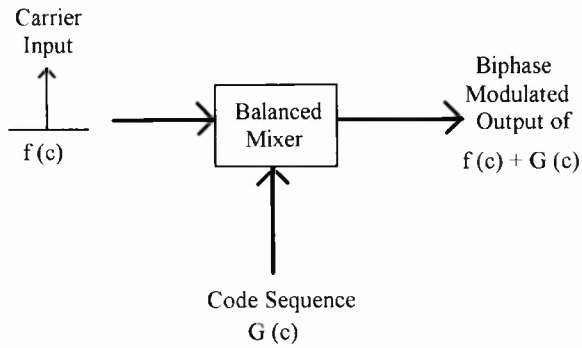

Fig 5.5.37: Direct Sequence System .

Here the pseudo-noise code sequence is used to modulate the 'conventional' carrier , ( which contains the baseband information ) , in a biphase or quadrature fashion.

The rectangular pulses of the code sequence , illustrated in fig 5.5.38 may be converted to the frequency domain via a fourier transform to obtain an expression for the code sequences frequency spectrum .

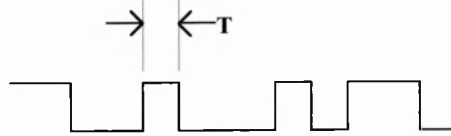

Fig 5.5.38: Code Sequence G (c) .

e.g.: Using the fourier integral for a rectangular pulse of duration 'T' and amplitude 'A' over  $T \pm \frac{T}{2}$  , and zero elsewhere gives;

$$C_n = \int_{-T/2}^{T/2} A \exp(-j\omega t) dt = \left[ \frac{A}{j\omega} \exp(-j\omega t) \right]_{-T/2}^{T/2}$$

$$\frac{A \exp(j\omega T/2) - A \exp(-j\omega T/2)}{j\omega} = \frac{2A}{\omega} \sin \frac{\omega T}{2} = TA \frac{\sin \omega T/2}{\omega T/2}$$

Which is of the  $\frac{\sin x}{x}$  form

This gives rise to a  $\left(\frac{\sin x}{x}\right)^2$  power spectrum .

e.g.:

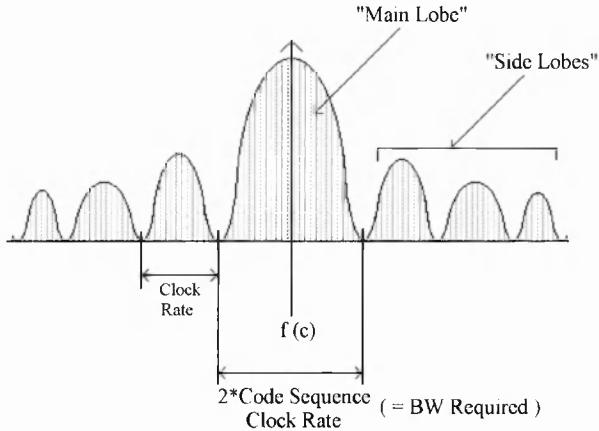

Fig 5.5.39:  $\left(\frac{\sin x}{x}\right)^2$  power spectrum .

When mixed with the carrier 'f (c)' the  $\frac{\sin x}{x}$  spectrum will be 'shifted' to centre around f (c) .

The signal lost , as a result of transmitting only the main lobe of the signal is negligible , only 10% of the power in BPSK and QPSK signals is contained in the sidelobes . It may therefore be only deemed necessary to transmit the main lobe bandwidth . The limiting factor which must be imposed at this stage is that the bandwidth of the main lobe must not exceed 150 kHz ( CENELEC standard , EN 50065-1 , for a PLC application ) . For the purpose of this particular analysis a band extending from 20kHz to 100kHz will be considered ( 80kHz bandwidth ) .

Therefore with the main lobe centred around f (c) , ( 60 kHz ) , the main lobe spectrum extends from 20 kHz to 100 kHz .

e.g.:

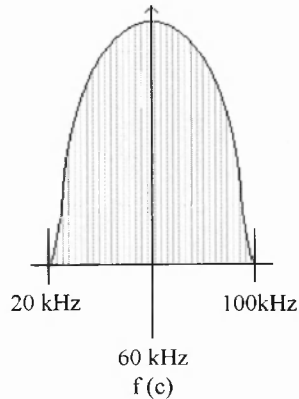

Fig 5.5.40. Main Lobe Bandwidth .

### **Synchronisation / Coherence .**

In order for the PN code sequence to correlate at the receiver and enable the 'conventionally' modulated carrier to 'drop out' and appear intelligible , the receivers PN code sequence must be coherent with that of the received signals sequence . Because the PN sequence consists of a rectangular pulse sequence occurring at the frequency of the code chip rate , the timing element of the code clock of both transmitter and receiver must be in synchronism .

As the PN code occurs only at the code chip frequency its phase synchronism and tracking are analogous to that of a coherent narrowband carrier . Synchronism and tracking may therefore be accomplished by sliding corrector and delay lock tracking methods , to name but a few . An in depth approach to these methods of maintaining coherence is provided by Dixon [72] . The much lower frequencies of code rate , associated with PLC Direct Sequence , make this task of synchronisation more manageable than it would be in the MHz range . However , this advantage is offset by the more unpredictable , dynamic , phase characteristics of the through transformer signalling channel .

### Phase Shift Effects:

If the phase response of the channel differs over the range 20 kHz to 100 kHz the fourier components of the  $\frac{\sin x}{x}$  spectra will undergo phase distortion .

In terms of a PLC channel , a transformer will introduce a varying phase characteristic over the  $\frac{\sin x}{x}$  bandwidth .

Upon reception these dispersive effects will degrade the receivers ability to correlate the locally generated code sequence with that of the received signal . The consequence of this effect is a 'rounding' of the 'ideal' correlators output .

e.g.:

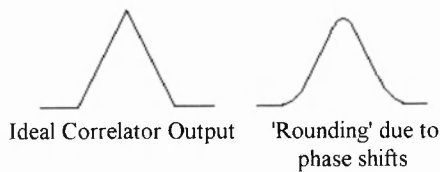

Fig 5.5.41: Correlator Degradation .

[ NOTE: This effect is also typical of reductions in system bandwidth ]

In order to quantify system degradation , due to phase shift effects , R.C.Dixon [72] may be quoted . " A figure of 2.38 dB reduction in jamming margin for 3 radians of phase shift from the centre frequency  $f(c)$  to the first 'null' is typical of system losses " . This loss in jamming margin must be accounted for when using direct sequence as a PLC . Fig 5.5.42 illustrates a typical transformer phase characteristic ( 50kVA , phase A8 / B8 to phase a / n ) . Here a phase displacement of  $\approx 115^\circ$  is present between the centre of the main lobe ( 60kHz ) and the first null ( 100kHz ) .

Now 3 radians =  $172^\circ$  . Therefore in order to provide a conservative estimate , which accounts for the extreme phase shifts which are present in some signalling modes , a loss of 3dB in jamming margin will be included in overall system degradation .



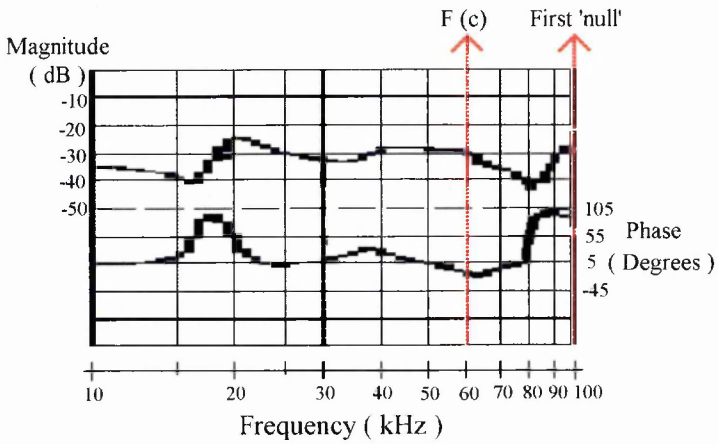

Fig 5.5.42. Transformer Phase Characteristics .

### Jamming Margin:

It is firstly appropriate to review the quantity of 'Process Gain' , associated with spread spectrum systems . With reference to Direct Sequence systems process gain may be expressed as follows;

$$\text{Process Gain} = (G_p) = 10 \log_{10} \frac{\text{Bandwidth of SS signal}}{\text{Data rate of baseband channel}} = \frac{BW_{RF}}{R_{info}}$$

With reference to equation 5.1 , section 5.5.2.1 , the Jamming Margin ( M<sub>j</sub> ) may be quantified by the following equation;

$$\text{Jamming Margin} = G_p - \left[ L_{sys} + \left( \frac{S}{N} \right)_{OUT} \right] = M_j$$

Where ,  $L_{sys}$  = System Implementation Losses  $\approx 3\text{dB}$   
 and  $\left( \frac{S}{N} \right)_{OUT}$  = SNR at information output  $\approx 15\text{dB}$

$$\therefore M_j = G_p - [3\text{dB} + 15\text{dB}]$$

$$M_j = G_p - 18\text{dB}$$

### Data Rate versus Attenuation Level:

A similar analysis may now be performed as with Chirp spread spectrum systems , section 5.5.2.1 . A maximum attenuation of 60dB will give rise to a required Jamming Margin of 6dB .

$$\text{Now ,} \quad M_j = G_p - 18 \text{ dB}$$

$$6 \text{ dB} = G_p - 18 \text{ dB}$$

$$G_p = 6 \text{ dB} + 18 \text{ dB} = \mathbf{24 \text{ dB}}$$

Taking into account the phase shift between the centre frequency and the main lobe first null , which will occur due to the phase distortion introduced by the transformers characteristics , system degradation must be accounted for . The previous discussion of this factor reveals a possible system degradation of up to around 3 dB , which must be compensated for by a corresponding increase in process gain . A requirement of around 27 dB of processing gain is therefore apparent .

$$\mathbf{G_p = 27 \text{ dB}}$$

Now ,

$$G_p = 10 \log_{10} \frac{BW_{RF}}{R_{data}}$$

Where  $BW_{RF}$  will be 80 kHz .

$$\therefore 27 \text{ dB} = 10 \log_{10} \frac{80 \text{ kHz}}{R_{data}}$$

$$\text{Hence ,} \quad 2.7 = \log_{10} \frac{80 * 10^3}{R_{data}}$$

Now taking antilogs of both LHS and RHS ,

$$501 = \frac{80 * 10^3}{R_{data}} , \therefore R_{data} = \frac{80 * 10^3}{501}$$

$$\mathbf{R_{data} \approx 160 \text{ bits per second}}$$

Therefore a data rate of approximately 160 bps will be reliably sustainable through a transformer which exhibits 60 dB of attenuation .

The previous set of calculations illustrate that with a fixed available bandwidth a trade-off exists between channel attenuation and achievable data rate . A certain data rate gives rise to a permissible level of attenuation , and vice versa . These two variables may be tabulated then expressed in a graphical fashion bearing in mind that the maximum channel capacity ( Shannon ) is twice the channel bandwidth ( = 2\*BWRF = 160 kbps ) .

$$\begin{aligned}
 \text{Now ,} \quad M_j &= G_p - \left[ L_{\text{sys}} + \left( \frac{S}{N} \right)_{\text{OUT}} + \text{Phase Distortion} \right] \\
 &= G_p - [3\text{dB} + 15\text{dB} + 3\text{dB}] \\
 &= G_p - 21\text{dB} \\
 \therefore G_p &= M_j + 21\text{dB}
 \end{aligned}$$

| Attenuation | Received signal level | Jamming Margin | Required Process Gain | Data Rate                  |
|-------------|-----------------------|----------------|-----------------------|----------------------------|
| 0 dB        | 5v                    | -54 dB         | -33 dB                | = Shannon limit            |
| 10 dB       | 1.6v                  | -44 dB         | -23 dB                | = Shannon limit            |
| 20 dB       | 0.5v                  | -34 dB         | -13 dB                | = Shannon limit            |
| 30 dB       | 0.16v                 | -24 dB         | -3 dB                 | = Shannon limit = 160 kbps |
| 40 dB       | 50mv                  | -14 dB         | 7 dB                  | <b>15,962 kbps</b>         |
| 50 dB       | 16mv                  | -4 dB          | 17 dB                 | <b>1596 bps</b>            |
| 60 dB       | 5mv                   | 6 dB           | 27 dB                 | <b>160 bps</b>             |
| 70 dB       | 1.6mv                 | 16 dB          | 37 dB                 | <b>16 bps</b>              |

Table 5.5.8: Data Rate Versus Attenuation .

Note: Above table is representative of 5V signal injection level .

The ability of the direct sequence system to function in the presence of attenuation levels in excess of narrowband systems is apparent, albeit with reduced data rate. This may be attributed to direct sequence systems possessing the property of process gain.

Now representing the data of table 5.5.8 graphically;

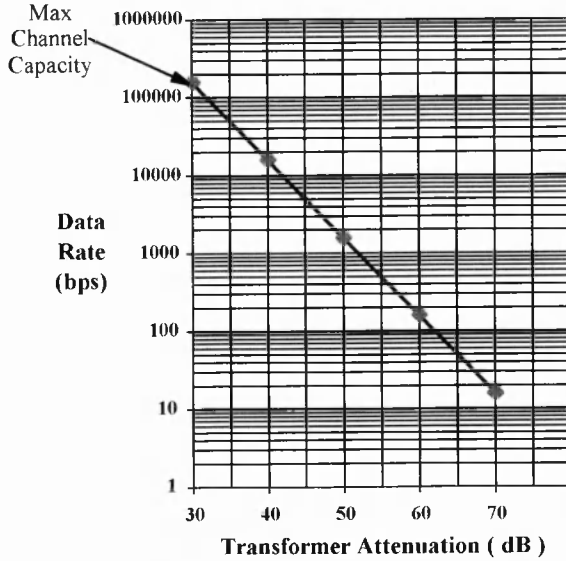

Fig 5.5.43: Transformer Attenuation Versus Data Rate ( 80kHz BW ).

The following table ( table 5.5.9 ) will give rise to a 'family' of curves ( plotted in fig 5.5.44 ), each associated with a different bandwidth.

| <b>Attenuation</b> | <b>Process Gain</b> | <b>Data Rate at 40kHz BW</b> | <b>Data Rate at 100kHz BW</b>  | <b>Data Rate at 150kHz BW</b> |
|--------------------|---------------------|------------------------------|--------------------------------|-------------------------------|
| 0 dB               | -33 dB              | = Shannon Limit              | = Shannon Limit                | = Shannon Limit               |
| 10 dB              | -23 dB              | = Shannon Limit              | = Shannon Limit                | = Shannon Limit               |
| 20 dB              | -13 dB              | = Shannon Limit              | = Shannon Limit                | = Shannon Limit               |
| 30 dB              | -3 dB               | = Shannon Limit<br>= 80 kbps | = Shannon Limit<br>= 2000 kbps | = Shannon Limit =<br>300 kbps |
| 40 dB              | 7 dB                | 8000 bps                     | 20 kbps                        | 30 kbps                       |
| 50 dB              | 17 dB               | 800 bps                      | 2000 bps                       | 3000 bps                      |
| 60 dB              | 27 dB               | 80 bps                       | 200 bps                        | 300 bps                       |
| 70 dB              | 37 dB               | 8 bps                        | 20 bps                         | 30 bps                        |

Table 5.5.9: Data Rate Versus Attenuation and BW .

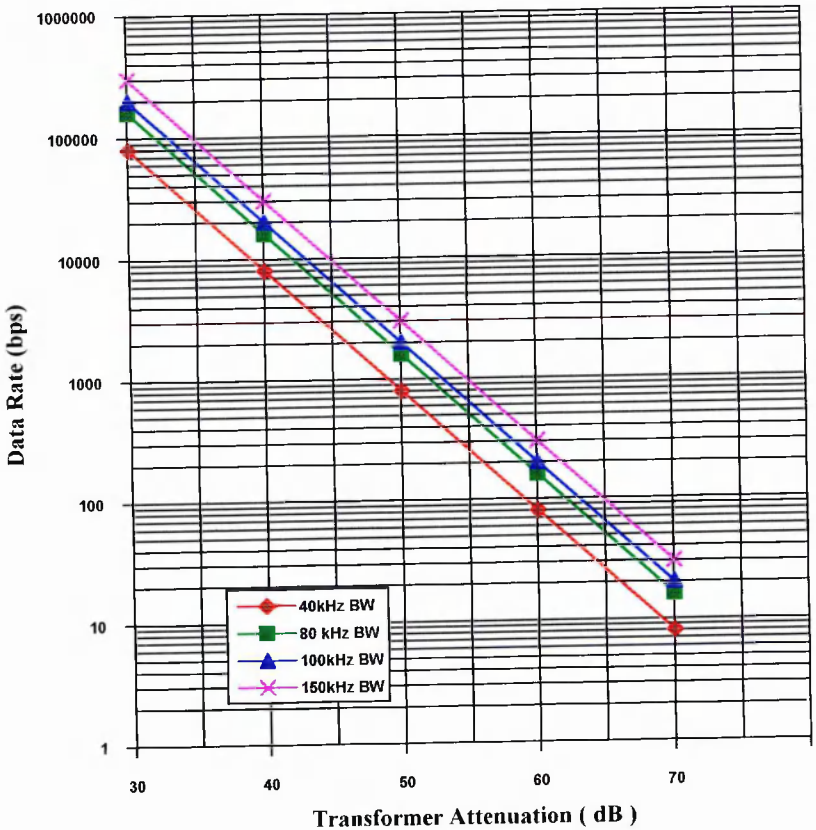

Fig 5.5.44: Data Rate of Different Bandwidths vs Attenuation .

The investigations made in this section lead to the following observations .

- ◆ By Direct Sequence standards , code rates are relatively low for PLC applications . This is due to limited available bandwidth being much less than in the MHz range . Consequently process gain will be much less then in its usual bands of operation .
  
- ◆ The slower chip rates ( code rates ) at PLC frequencies do ease the task of code generation and synchronisation . However , phase distortion ( inherently present in the transformers frequency characteristics ) degrades the achievable process gain . This factor

will correspondingly reduce the achievable data rate , in the presence of attenuation , over a fixed bandwidth .

◆ The previous observation highlights the trade-off which must be made between bandwidth and data rate in the presence of varying degrees of attenuation . This factor is summarised graphically by fig 5.5.44 .

◆ The graph of fig 5.5.44 and table 5.5.9 illustrate that at attenuation levels of  $\leq 30\text{dB}$  the data rate is governed by the channels theoretical maximum capacity ( Shannons law ) . At these levels of attenuation data rate is no longer governed by system process gain . Moreover , at these levels of attenuation it has been shown that narrowband systems may function with acceptable error rates . However , at the other end of the scale if the direct sequence system is to function in the presence of higher levels of attenuation a large increase in process gain is required . Hence a trade in data rate is necessary .

The extremely low data rates , necessary in high levels of attenuation , highlight the limitation of direct sequence . It may well be appropriate to use low frequency narrowband techniques in these conditions as they are equally as robust whilst providing the same order of data rate , yet are simpler to implement . It may therefore be concluded that direct sequence appears to occupy a 'middle' ground , in terms of attenuation and data rate , which must be considered in its use as a PLC .

## **5.6 Summary**

This current chapter of experimental work commenced by revealing the similarities between the frequency responses of different transformer connection configurations within a signalling mode . The results of this investigation were used to avoid the duplication of unnecessary 'on site' tests , as well as establishing a 'pattern' in the responses of differing configurations . A programme of designing , constructing and testing suitable coupling circuits then followed in order to facilitate the connection of test equipment to 11kV supplies .

Having completed and drawn conclusions from the preliminary investigations the main bulk of experimental work was then covered . This portion of the chapter could be divided into two sections which would cover the transformers frequency characteristics when related to narrowband and wideband modulation systems . In these sections ( 5.5.1 and 5.5.2 ) the theory of modulation techniques , discussed in chapter 4 , was combined with the experimental results of the current chapter in order to determine through transformer signalling bands .

With the experimental work completed it now remains necessary to draw together the conclusions of its findings and relate them to the PLC network architectures and services discussed in chapter 2 . This topic of discussion is reserved for the conclusions of chapter 6 .



## Chapter 6 Conclusions

The opening chapter of this thesis reviewed the governments 1989 electricity act , placing emphasis on the timetable of introducing second tier supply . With the introduction of second tier supply , the requirement that RECS must develop a viable communication infrastructure , which encompasses all consumers , was evident . Several architectures and mediums were considered for the provision of such a communication system . This investigation led to an important conclusion . The most desirable medium and architecture , from the RECS viewpoint , would involve the use of electrical distribution feeders as the communication medium with a communication architecture which necessitates a through transformer signalling strategy of the form illustrated in fig 6.1 .

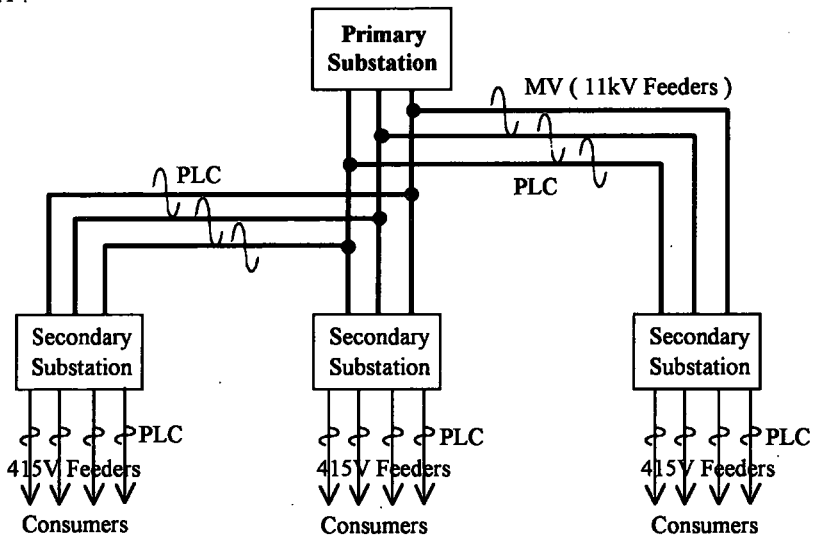

Fig 6.1: Through Transformer Architecture .

Having reviewed studies concerning the use of PLC's on LV and MV networks , it became apparent that little research had been devoted to the element common to both these networks - the distribution transformer . The fact that this 'gap' in knowledge must be filled , before a 'through transformer' architecture may be realised , formed the basis of this research .

## **6.1 Architecture / Data Rates**

In the development of any communication system it is vital to provide a definite outline of the architecture and topology within which it must operate . A study of a portion of MANWEBs' Mid Mersey 11kV / 415V distribution network revealed striking differences in consumer / transformer ratios between urban , semi rural and rural areas . For the purpose of estimating network data rates a 'minimum service' was defined which the RECs must provide in order to conform to the requirements of the 1989 electricity act . A minimum service was defined as the provision of meter read , multiple tariff rates and load control . The message lengths of these services , used in conjunction with the network architecture study , may be used to estimate through transformer data rate requirements .

The findings of this study revealed the through transformer signalling rate to be surprisingly low , in the order of tens of bits per second range . However , it must be borne in mind that these data rates are representative of a systems average data rate over a period of time . In reality , due to the finite response times of system elements , these data rates will be greater , but not by orders of magnitude . Moreover , the minimum service system may well prove inadequate for future REC and consumer needs . This study does however provide a basis to asses the feasibility of a through transformer signalling architecture to sustain a minimum service data rate .

## **6.2 Transformer Frequency Response**

The experimental results of these investigations may be divided into two categories , namely , unenergised and energised responses .

Unenergised: Out of the three signalling modes the phase / tank mode provided the most favourable signalling characteristics . It was in fact revealed that the entire frequency

range up to 150kHz was available for signalling ( fig 5.5.12 , section 5.5.1.2 , chapter 5 ) . Also this mode of signalling provided the 'flattest' propagation profiles ( fig 5.2.3 and fig 5.2.4 , section 5.2.1 , chapter 5 ) , in every transformer investigated ( table 5.5.2 ) . In contrast phase / neutral and phase / phase modes exhibit a much more dynamic propagation characteristic ( fig 5.5.13 and fig 5.5.14 , section 5.2.1 , chapter 5 ) . Hence , only portions of the frequency range ( 1kHz to 150kHz ) will support narrowband signalling systems . With this in mind , any narrowband carrier must be sited in a propagation 'window' .

**Energised:** With the transformer in its energised state the bandwidth available for a narrowband carrier is decreased . Deeper and wider attenuation troughs are present , in all modes of signalling , when the transformer is powered up . However it does not appear that it is the energised core and windings which impairs propagation , rather the connection of the transformer to the LV supply network introducing loading effects . From these energised characteristics it is evident that although not all of the frequency range is available for narrowband systems , phase / tank mode signalling offers the most favourable propagation characteristics .

**Propagation Windows:** With reference to fig 6.1 it is evident that in considering a duplex PLC two directions of transmission are possible , namely , primary substation to consumer ( downstream ) and consumer to primary substation ( upstream ) . It therefore follows that a downstream transmission must be capable of propagating through every substation transformer , whilst upstream transmissions need only propagate through the 'local' substation transformer .

In the case of a narrowband system a downstream transmission must have its carrier located in a propagation window which is common to all transformers within its wide area network . Although the results of section 5.5.1.4 , chapter 5 , indicate the existence of common propagation windows approaching 100kHz and above , it would seem probable that a greater range of transformers would not possess common

propagation windows . In other words a narrowband system would not be expected to perform well in a through transformer architecture . However , over the range of transformers covered in this research , common propagation windows were present . These factors highlight the need to analyse the characteristics of a greater range of transformers .

Having assessed the performance of spread spectrum systems , with respect to the transformers frequency characteristics , the following conclusions became evident . Direct sequence and chirp systems were able to reliably function in the presence of attenuation levels as low as those of the severest propagation troughs . The price paid for this robust performance is a reduction in data rate , with increased bandwidth . In order to cope with the most unfavourable propagation characteristics the data rates of chirp and direct sequence must be reduced to  $\approx 400$  bps and  $\approx 200$  bps respectively ( 100kHz bandwidth ) . The assessment of frequency hopping spread spectrum reveals that unacceptably high error rates would occur in the presence of propagation characteristics typical of energised transformers .

In the investigations of low frequency signalling techniques ( section 4.7 , chapter 4 ) it was found that established through transformer systems exist , but are only capable of data rates in the region of tens of bits per second .

To conclude this current section , three factors are evident .

i) Narrowband systems rely on a common propagation window . This is unlikely to occur in a wide area network . Hence , narrowband is not a good candidate for a through transformer strategy .

ii) Direct sequence and chirp spread spectrum do not rely on common propagation windows and are therefore particularly suited to through transformer signalling , with data rates in the hundreds of bits per second region . However the use of direct sequence , in

the presence of channel phase shifts , does require a certain degree of dynamic phase tracking . This may be accomplished using 'sliding correlator' and 'tau-dither' tracking methods . Frequency hopping however seems unsuitable for a through transformer signalling technique .

iii) Low frequency systems ( <10kHz ) provide a viable through transformer technique if low data rates ( tens of bits per second ) are tolerable .

### **6.3 Data Rates / Service**

In adopting a through transformer PLC architecture the necessary data rate must be quantified in order to determine the required signalling technique . From this research several conclusions may be made .

i) If only a 'minimum service' is required ( section 2.4 , chapter 2 ) only very low data rates are necessary . In this case low frequency narrowband <10kHz and ultra narrowband will sustain the required data rates whilst providing a simple yet robust system .

ii) The use of direct sequence and chirp spread spectrum supports through transformer architecture but with a higher data rate than low frequency narrowband and ultra narrowband . These higher data rates , in the hundreds of bits per second range , may be used to build an upwardly compatible system . In other words additional services may be provided if or when demand necessitates them .

iii) Which Modulation Scheme?: Because a PLC must operate within the constraints of varying degrees of attenuation and within strict bandwidth limits , whilst providing the required data rate , a trade-off must be met when choosing the appropriate modulation technique . In referring to tables 5.5.7 and 5.5.9 of sections 5.5.2.2 and 5.5.2.4 of chapter 5 respectively , a trade-off may broadly be defined .

Attenuation  $\leq 30\text{dB}$ ; In this domain the data rate of direct sequence and chirp is limited by the channels theoretical maximum capacity . The levels of attainable process gain become irrelevant at low levels of attenuation . It would therefore seem pointless to use spread spectrum systems in this range of attenuation , in any case narrowband systems operate quite adequately in this region with greater bandwidth efficiency .

Attenuation  $>60\text{dB}$ ; In this region the necessary process gain which direct sequence and chirp require results in reduced data rates ( tens of bits per second ) . Although direct sequence and chirp posses the ability to operate in these levels of attenuation their reduced data rates may be matched by low frequency narrowband and ultra narrowband ( which take advantage of the lower attenuation levels present at low frequencies ) . This would suggest the use of low frequency and ultra narrowband systems in this area of operation , as they are less costly to implement than spread spectrum systems .

Attenuation  $30\text{dB}$  to  $60\text{dB}$ ; This 'middle ground' in attenuation would seem to justify the use of direct sequence and chirp . In this region the operational limit of narrowband is surpassed whilst the achievable data rates of direct sequence and chirp remain orders of magnitude greater than those of low frequency narrowband and ultra narrowband .

These conclusions suggest the most appropriate modulation scheme to use under a set of operational constraints .

## **6.4 Enhanced Performance**

During the experimental work of chapter 5 results were obtained which suggest that selected choice of frequency range , together with certain phase connections within a signalling mode , would reduce through transformer attenuation levels . From these results ( section 5.5.1.3 , chapter 5 ) the following conclusions may be realised .

i) Three Phase Transformer Symmetry; With reference to fig 6.2 ,

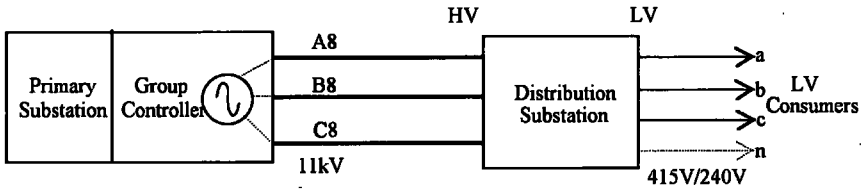

Fig 6.2: Transformer Symmetry .

LV to HV Transmissions; In this direction of transmission a signal will invariably be injected between LV phase and neutral . Results from section 5.5.1.3 , chapter 5 , indicate that a signal injected between a given LV phase and neutral will propagate more favourably to certain HV phases . As this relationship is predictable in nature a group controller , sited in the primary substation , may be configured to receive an LV transmission between the HV phases which facilitate best propagation .

HV to LV transmission; In this direction a similar reasoning and conclusion is applicable . If the LV phase of destination is defined , the group controller may be configured to transmit between a predetermined set of phases . This will enhance signal propagation .

The phase connections which posses the most favourable characteristics are defined in section 5.5.1.3 , chapter 5 .

ii) High pass / low pass filter action; Another set of results ( fig 5.5.25 , section 5.5.1.5 , chapter 5 ) which gave rise to some important conclusions was that of the high and low pass filter action of the distribution transformer . To reiterate these findings , propagation from LV to HV produced a low pass response whilst HV to LV propagation exhibited a high pass response . The implications of these findings are that in order to enhance signal propagation , transmissions from LV to HV may be sited at lower frequencies (  $\approx 10\text{kHz}$  ) , whereas HV to LV transmissions may be placed at frequencies at the upper end of the 3kHz to 150kHz band .

## **6.5 System Economics**

The findings of this research have shown that a through transformer architecture is feasible . Furthermore , data rates are possible which provide a margin of 'headroom' which may be used in the future to augment a minimum service system . However , in providing a degree of upward compatibility , in the form of higher data rates , system complexity and cost are increased .

It is expected that this economic trade-off will be the prime factor in the choice of any communications system . A compromise may well be necessary between the degree of service the consumer desires and the level of service the REC is willing to provide . From this decision the REC must determine the most cost effective way of implementing the service . Variables such as network location , be it urban , semi rural or rural , must be considered . The conclusion of this research would suggest that a PLC , through transformer system , is particularly suited to rural networks - for the following reasons .

- ◆ The cost per consumer for installing PSTN or fibre links to every secondary distribution transformer is high due to the greater numbers of distribution transformers on this type of network ( section 2.3 , chapter 2 ) .
- ◆ The lower ratio of consumers per primary distribution transformer will ensure a lower through transformer signalling rate . This favours the use of PLC signalling .

On the contrary in densely populated urban areas , through transformer signalling rates will be higher . This type of network would also require fewer PSTN / fibre to transformer links , because of the lower numbers of distribution substations ( section 2.3 , chapter 2 ) . This network layout does not exclude the use of a PLC system , it merely allows PSTN / PLC and fibre / PLC hybrids ( fig 1.10 and fig 1.11 , section 1.5 , chapter 1) to be considered as a viable option .



It must also be borne in mind that in being subjected to the current philosophy of using a complex system to cope with the harsh powerline environment , simpler more cost effective methods are not overlooked . The lower frequency techniques of section 4.7 , chapter 4 , provide a means of implementing low data rate systems , capable of sustaining a minimum service system , at a lower cost than a spread spectrum approach . Furthermore , the prospect of enhancing the data rates of low frequency systems , with the use of multi-level baseband codes , remains a viable option .

This research appears to have answered the question "is it possible to propagate signals through a distribution transformer at a 'usable' data rate?" Now what remains is for the RECs to answer the question "to what degree is economically justifiable?"

## **6.6 Further Work**

In the limited period of time available for this research , several topical areas were considered which merit further or additional attention .

- ◆ Extension of the network study of section 2.3 , chapter 2 , to cover a wider area from which a more extensive data rate study may be made for a system which provides extended services .
- ◆ Study of the available signalling bandwidth for through transformer signalling with the transformer in its operational 'on line' state , connected in the supply network .
- ◆ Extension of this study to cover a wider range and greater number of transformers .
- ◆ Investigation into 11kV coupling circuits , design and construction .

◆ Assessment of performance ( data rates versus attenuation ) of various modulation schemes when used under through transformer signalling conditions on an operational 11kV / 415V distribution network .

## **References:**

[1] A.G.Burr "Computer Modelling of the LV Distribution Network for High Frequency Signalling" . A dissertation submitted to the University of Bristol in support of an application for the degree of Doctor of Philosophy in Electrical Engineering . Dec 1983 .

[2] J.D.Suh "Multiconductor Signal Propagation in Distribution line Carrier Networks" . A thesis submitted to the Graduate Faculty of North Carolina State University in partial fulfilment of the requirements for the degree of Master of Science . 1988 .

[3] "Underground Cable Fault location" , Barry Clegg . Newnes , 1991 .

[4] "Telecontrol , teleprotection and associated telecommunications for electric power systems" . Distribution automation using distribution line carrier systems , Part 1 , General considerations , section 4 , Identification of transmission parameters concerning medium and low voltage distribution mains , WG09 , Dr Schroppel , Germany , July 1993 , p1 to 26 .

[5] R.M.Vines , H.J.Trussell , K.C.Shuey , J.B.O'Neal Jr . "Impedance of Residential Power distribution Circuit" . IEEE Transactions on Electromagnetic Compatibility , Vol EMC 27 No1 , Feb 1985 , p6 to 12 .

[6] A.G.Burr , R.F.Burbidge , J.E.Revett "An investigation of the Propagation of High Frequency signals over LV mains Distribution Networks Using Computer Modelling and Direct Measurements" . University of Bristol & Thorn EMI . IEE Conference Publication 217 . 1982 , p104 to 107 .

[7] A.G.Burr , R.F.Burbidge "Computer Modelling of the LV Distribution Network for Mainsborne Signalling" . IEE Proceedings , Vol 134 , Pt C , No1 , Jan 1987 , p83 to 94 .

- [8] R.Cortina , G.Piolini , S.Celozzi , M.D.Amore "Telecommunication Systems on Power Distribution Networks: High Frequency Performances of Carrier Channels . ( ENEL ) , IEEE 1993 , p1 to 7 .
- [9] M.A.Redfern , Z.Bo , R.F.Ormondroyd , P.McGuinness and H.T.Yip "High Voltage Underground Cable Data communications for High Speed Unit Protection and Control" . IEE International Conference on Advances in Power System Control , Operation and Management . Nov 1991 , Hong Kong , p244 to 249 .
- [10] "Mainsborne - Research on Communication Across a Transformer" . Thorn EMI Central Research Laboratories . May 1984 .
- [11] R.Cortina , G.Piolini , S.Celozzi , M.D.Amore "Telecommunication Systems on Power Distribution Networks" . IEEE , 1993 , p1 to 7 .
- [12] Electric Cables Handbook , 3rd Edition , 1989 . Newnes Technical Publications .
- [13] J.S. Hedin and L.H Paulsson "Application and Evaluation of a New Concept for Series Compensation for Distribution Networks." Gullspangs Kraft A B, Sweden, A B B Power Systems, Sweden . 1994 , ( private communication ) .
- [14] R.M. Vines "The Characterisation of Residential Impedance's and Noise Sources for Power Line Carrier Communications." -A thesis submitted to the Graduate Faculty of North Carolina State University. 1983
- [15] J.B. O'Neal Jr "The Residential Power Circuit as a Communication Medium", North Carolina State University. IEEE Transactions on Consumer Electronics, Vol CE-32, No.3 Aug 1986 , p567 to 576 .
- [16] "The J&P Transformer Book" , 4th Edition , 1985 . Stigant , Lacey and Franklin

- [17] "An Optimum Communication Concept for Electrical Distribution Networks " ROBCOM, ENEL, *Datawatt*, The Sorento Paper . 1993 .
- [18] J.R. Nicholson and J.A. Malack " RF Impedance of Power Lines and Line Impedance Stabilisation Networks in Conducted Interferences Measurement." IEEE Transactions on Electromagnetic Compatibility Vol EMC -15, No 2, May 1973 , p163 to 168 .
- [19] J.A. Malack and J.R. Engstrom "RF Impedance of United States and European Power Lines" IEEE Transactions on Electromagnetic Compatibility, Feb 1976 ,p36 to 38.
- [20] E.Martinez Yague and J. Cerrada, "LV and MV Communication Systems Installed and Tested in Facilities of Hidroelectrica, Espanola S.A." . RGE No 10/92 , Nov 1992 , p15 to 19 .
- [21] Electricity Association Review , 1988 .
- [22] J.R Formby and R.N. Adams, "The Mains Network as a High Frequency Communications medium." Report published by the Electricity Councils Research Programme, Jan 1970.
- [23] A.A. Smith "Power Line Noise Survey" IEEE Transactions on electromagnetic compatibility, Vol EMC 27, p84 -86, May 1973.
- [24] R.M. Vines, H.J. Trussell, L.J. Gale and J.B. O'Neal Jr, "Noise on Residential Power Distribution Circuits" IEEE transactions on Electromagnetic Compatibility, Vol EMC 26, p161- 168, Nov 1984.
- [25] "Specification for Signalling on low- Voltage Electrical Installations in the Frequency Range 3KHZ to 148.5 KHZ", Part 1, General requirements, frequency bands and electromagnetic disturbances. European Standard EN 50065- 1, 1991

- [26] M.H.L. Chan and R.W. Donaldson, "Amplitude, Width and Interarrival Distributions for Noise Impulses on Intrabuilding Power Line Communication Networks." IEEE Transactions on Electromagnetic Compatibility, Vol 31, No. 3, August 1989,p320 to 323.
- [27] M.H.Chan and R.W.Donaldson "Attenuation of Communication Signals on Residential and Commercial Intrabuilding Power Distribution circuits" . IEEE Transactions on Electromagnetic Compatibility , Vol EMC 28 , No 4 , November 1986 , p220 to 230 .
- [28] W.R.DeWilde , H.Baleriaux and M.Cailliau . "Data Communication on the Low Voltage Mains: 'Argus' Project Belgium " . CIRED 11th International Conference on Electricity Distribution , p5.8/1-6 , Vol 5 , April 1991 .
- [29] J.Edwards , T.G.Tang . "Computerised Control of Maximum Electrical Energy Demand in Consumer Premises". Conference on Electrical Energy , Australia , Oct 1992 , p149 to 151 .
- [30] F.Schwepe . "Unit Commitment Scheduling of Electric Power Systems" . MIT Energy Laboratory , Cambridge , Mass . 1991 , p116 to 128 .
- [31] Mo-Shing Chen . "Electrical Power Industry; Today and Tomorrow" . IEE International conference on Advances in Power System Control , Operation and Management , November 1991 , Hong Kong , p30 to 37 .
- [32] J.H.Reeves , "An Integrated Approach to Load Management , Domestic Heating and Telecontrol" , EA Technology Report , Jan 1993 .
- [33] C.O.Bjork and B.G.Karlsson . "Load Management Applications for Industrial Loads". IEEE PES Winter Meeting , 1985 , p1 to 4 .

- [34] M.V.Krishna Rao , J.V.Pendurangam , R.Peri , K.N.Clinard , C.Radha Krishna .  
"Development and Evaluation of a distribution automation system for an Indian Utility" .  
IEEE Transactions on Power Delivery , Vol 10,No 1 , Jan 1995 , p452 to 459 .
- [35] R.Van.Dootingh . "ESPRIT Home Systems Project". IEEE Transactions on  
Consumer Electronics , Vol 36 , 1990 , p612 to 618 .
- [36] G.Casa and P.Mirandola . "Distribution Automation System to Provide Friendly  
Home User Utility Interface" . Transmission and Distribution International , Vol 3 , Iss 4 ,  
Dec 1992 , p38 to 42 .
- [37] C.Douligeris . "Intelligent Home Systems" . IEEE Communications Magazine , Oct  
1993 , p52 to 61 .
- [38] P.C.Hunt , "The Turtle Automatic Meter Reader , Final Report" . Hunt Technologies  
Inc . Oct 1994 .
- [39] "Distribution Automation System , New Metering Apparatus" , ENEL Product .  
1994 .
- [40] "Mainsborne Telecontrol System , Introduction to Equipment , System and  
Operation" . Thorn EMI Electronics Ltd . July 1993 .
- [41] T.Turnbridge . "Remote Meter Reading moves Closer" . Electrical Reveiw , Vol 227  
, No 2 , Jan 1994 , p30 to 32 .
- [42] C.L.Bezuidenhout . "Energy Management by Remote Interrogation of Meters" .  
Elektron , April 1994 , p9 to 11 .
- [43] "Mainsborne Mains Message Protocols" , Thorn EMI Electronics Ltd October 1990.

[44] W.R.De Wilde , H.Baleriaux , M.Cailliau . "Data Communication on the Low Voltage Mains: ARGUS Project , Belgium" . CIRED 11th Conference on Electrical Distribution , Vol 15 , May 1991 , p5.8 / 1-6 .

[45] "Report on Mainsborne customer telemetry trials in London and Milton Keynes ( 1984 to 1985 )" volumes 1 &2 , THORN Security Limited .

[46] J.Edwards , T.G Tang . "Design and Application of PLC Communication Equipment" . IREE CON , 91 , Australia's Electronics Convention , Sept 1991 , IREE 1992 , p409 to 411 .

[47] J.Vuori , J.Skytta . "Communication Using Spread Spectrum Modulation on Electric Power Distribution Circuits" . Proceedings of Eusipco 92 , 6th European Signal Processing Conference Vol 3 , 1992 , p1599 to 1602 .

[48] K.P.Wacks . "The Impact of Home Automation on Power Electronics" , APEC '93 , 8th Annual Applied Power Electronics Conference and Exposition , 1993 , p3 to 9 .

[49] M.Nakagawa . "Consumer Communications Based on Spread Spectrum Techniques" . IEEE ISSSTA '94 , IEEE 3rd International Symposium on Spread Spectrum Techniques and Applications , July 1994 , p138 to 145 .

[50] "CEBus Power line Evaluation Kit , User Manual" . Intellon Corporation 1992 .

[51]"ECHELON PLE 30 Power line Evaluation Kit Users Guide" . Echelon Corporation . 1993 .

[52] "Cyplex Integrated Circuit Spread Spectrum Evaluation Kit Users Manual" . Cyplex Corporation 1993 .



[53] "Signalling on Low Voltage Electrical Installations , Mains Communications Systems Protocol and Data Integrity and Interfaces" . EN 50090, Home and Building Electronic Systems Standard . IEC WG3 Nov 1994 .

[54] H.Sidhu "MV Signalling Study - Initial Report" . Thorn Security and Electronics . Sept 1992 .

[55] M.Byars , D.Howson . "Remote Control of 11kV Plant by Mains Signalling" . Third International Symposium on Distribution Automation and Demand Side Management . Jan 1993 , p198 to 204 .

[56] J.R.Formby . "Power line Carrier Communication for Electricity Distribution Network Automation" . Electricity Association . SIRA Conference , Autumn 1992 , ( private communication ) .

[57] A.D.Bartlett. "Optical Communications for Power Supply Utilities" . East Midlands Electricity . Power Technology International . 1992 , p157 to 161 .

[58] K.P.Morf. "Mixed Use of Optical Fibre Communications and PLC Techniques in Telecommunication Networks for Electrical Power Utilities" , IEE International Conference on Advances on power system Control / Operation and Management , Nov 1991 , Hong Kong , p260 to 264 .

[59] S.Lewis. "National Grid Transports More than just Electricity". Transmission & Distribution International , 1994 , p11 .

[60] "Badger" Remote Meter Reading System , product description / operation . A Report from Badger Meter Inc , March 19th 1993 .

- [61] A.I.McCartney. "Load Management Using Radio Teleswitches Within NIE". Northern Ireland Electricity . ( private communication ) , June 1993 .
- [62] M.R.Gasteen and R.F.Burbidge. "Computer Modelling of Distribution Networks to Predict the Propagation of Mains Marked Signals for Tariff and Load Control". Univ of Bristol . IEE Conference Publication 217 . 1982 , p113 to 117 .
- [63] Mo-Shing Chen . "Electrical Power Industry ; Today and Tomorrow" . IEE International Conference on Advances in Power System Control and Management , Nov 1991 , Hong Kong , p241 to 248 .
- [64] J.M.Barstow . "A Carrier System for Rural Service" . AIEE Transactions Vol 66 , 1947 , p501 to 507 .
- [65] N.Nagaoka , N.Mori , A.Ametani . "Improvement of PLC Communication Reliability Using Multi Frequency Carrier" . 3rd International Symposium on Consumer Electronics . IEE , Nov 1994 , p388 to 393 .
- [66] D.Bacon "FEC , CRCS and Error Correction" . Electronics and Wireless World , May 1991 , p415 to 420 .
- [67] "Electronic Communication Sytems" . Kennedy & Davis , McGraw Hill . 2nd Edition 1987 .
- [68] "Principles of Communication Systems" . H.Taub & D.L.Schilling , McGraw Hill . 4th Edition . 1993 .
- [69] T.Schaub , W.Hagmann . "The Key Elements of Success for Distribution Line Carrier ( DLC ) Systems . Report from Landis and Gyr , Switzerland , p248 to 252 .

- [70] "Comparison of the Different Types of Modulations for the Home Power line Carrier" . Report by Electricite De France , R & D division , June 1993 .
- [71] J.Suohpera , T.Salo , P.Eerola . "Two Way Distribution Line Carrier Technology for Remote Meter Reading and Controlling Dynamic Tariffs" . Electricity Supply Engineers Association of New Zealand . June 1992 , p103 to 113 .
- [72] "Spread Spectrum Systems with Commercial Applications , Third Edition" . R.C.Dixon , Wiley Inter Science . 1994 .
- [73] "Modern Communications and Spread Spectrum" . G.R.Cooper and C.D.McGillem , McGraw-Hill Book Company . 1st Edition . 1992 .
- [74] Telecontrol , Teleprotection , and Associated Telecommunications for Electric Power Systems . Distribution Automation Using Distribution Line Carrier Systems , Part 3: Mainsborne Signalling requirements , Section 3 : Wideband Modem . IEC Technical Committee No 57 , August 1992 , p3 to 17 .
- [75] D.R.Adams "Mains Signalling Systems - an Overview" , Electrical Review , Oct 1993 , p43 to 44 .
- [76] P.M.Schumacher "Understand the Basics of Spread Spectrum Communications" . Microwaves & RF , May 1993 , p149 to 160 .
- [77] J.Neval "History and Theory of Ripple Communication Systems" . Landis & Gyr Inc. , California . Private Communication . 1994 , p2.3-1 to 2.3-6 .
- [78] S.Mak , D.Radford . "Design Considerations for Implementation of Large Scale Automatic Meter Reading Systems" . Distribution Control Systems Inc. , USA , IEEE , 1994 , p1 to 7 .

- [79] S.T.Mak , R.L.Maginnis . "Power Frequency Communication On Long Feeders and High Levels of Harmonic Distortion" . IEEE 1995 , p1 to 6 .
- [80] S.Y.Kwankam , N.N.Ningo , J.Bilkha , F.Nematchoua and J.M.Ngundam . "Application of a New Digital Power Line Communication Technology to Remote Reading of Standard Electric Utility Meters" . Proceedings of the 35th Midwest Symposium on Circuits and Systems . IEEE 1992 , p1534 to 1537 .
- [81] S.Hoshino . "Centralised Load Control and Automatic Meter Reading System for Distribution Line" . Tokyo Electric Power Company ( TECPCO ) . Private Communication . 1993 , p132 to 136 .
- [82] "Distribution Automation Using Distribution line Carrier Systems , Part 1 , General Considerations , Section 2 - Guide for Specification" . International Electrotechnical Commission , Technical Committee No. 57 , WG09 , Dec 1992 , p3 to 24 .
- [83] E.L.Thompson , T.Olsen . "High Speed Data Links Using Power Line Carrier Equipment" . IEE International Conference on Advances in Power System Control , Operation and Management . Nov 1991 Hong Kong , p255 to 259 .
- [84] "The Governments Proposals for the Privatisation of the Electricity Supply Industry in England and Wales" . Secretary of State for Energy . Government White Paper , February 1988 .
- [85] "Metering Consultation Paper" . *Offer* ( Office of Electricity Regulation ) , January 1992 .
- [86] R.Bryan Seal "Integrated Communications Project - A Remote Metering Case Study" . AMRA ( Automatic Meter Reading Association ) News , April 1993 , p8 to 9 .

- [87] R.Dettmer "Meter Power" . IEE Review , June 1992 , p237 to 240 .
- [88] "The Competitive Electricity Market From 1998" . *Offer* ( Office of Electricity Regulation ) , January 1995 .
- [89] J.C.Whittaker "Protection Co-ordinated with Communication and Control" . IEE International Conference on Advances in Power System Control , Operation and Management , November 1991 , Hong Kong , p38 to 44 .
- [90] J.Douglas "Reaching out With Two Way Communications" . EPRI Journal ( Electrical Power Research Institute ) , September 1990 , p6 to 13 .
- [91] F.C.Scweppe , M.C.Caramanis , R.D.Tabors , R.E.Bohn , "Spot Pricing of Electricity" . Kluwer Academic Publishers , 1988 , p3 to 28 .
- [92] A.Plumpton "Organiation and Management of the UK Electricity Supply Industry" . IEE International Conference on Advances in Power System Control , Operation and Management , November 1991 , Hong Kong , p21 to 29 .
- [93] H.Kirkham , A.R.Johnston , G.D.Allen "Design Considerations for a Fiber Optic Communications Network for Power Systems . IEEE 1993 , p1 to 5 .
- [94] L.Effler , H.Steiner , H.Wagner "Load Management and Energy Import Optimization" . Siemens AG . Private Communication . 1993 , p4.19.1 to 4.19.6 .
- [95] R.Peri "Load Control for Rural India" . Transmission and Distribution International , Fourth Quarter 1994 , p26 to 30 .
- [96] K.P.Wacks "Utility Load Management Using Home Automation" . IEEE Transactions on Consumer Electronics , Vol 37 , No 2 , May 1991 , p168 to 174 .

[97] Babu & Ram "Tariffs and load Management: A Post Privatisation Study of the UK Electricity Supply Industry" . IEEE 1994 , p1 to 7 .

[98] H.Dorey "Low Power Radio and Metering" . IEE Colloquium on Low Power Radio and Metering , 16th February , 1994 , p1/1 to p1/2 .

[99] H.B.Stauffer "Smert Enabling System for Home Automation" . IEEE Transactions on Consumer Electronics , Vol 37 , No.2 , May 1991 , pxxix to xxxv .

[100] "Home Systems - Information Entertainment and Control" . IEE Colloquium , 1st October 1990 , parts 2 to part 5 .

[101] F.Babich "Home Network Requirements. The ESPRIT HS Proposal" . European Strategic Programme for R&D on Information Technology , Vol.5 , No.1 , Jan-Feb 1994 , p93 to 105 .

[102] T.Meek , P.Chilese "Remote Meter Reading By Radio - A European Perspective" . Schlumberger Industries , UK . IEE 7th International Conference on Metering Apparatus and Tariffs for Electricity Supplies , November 1992 , p196 to 200 .

## List of Figures and Tables

| <b>Figure Number</b> | <b>Title</b>   | <b>Page</b> |
|----------------------|--|-------------|
| 1.1:                 | The Electricity Supply Industry                        | 7           |
| 1.2:                 | Radial System  | 8           |
| 1.3:                 | Loop System  | 9           |
| 1.4:                 | Primary Network Systems                                | 10          |
| 1.5:                 | Common Secondary Main                                  | 11          |
| 1.6:                 | Continuous Secondary Main                              | 12          |
| 1.7:                 | Grid Network   | 13          |
| 1.8:                 | The twelve area Electricity Boards                     | 15          |
| 1.9:                 | Cyclocontrol   | 25          |
| 1.10:                | PLC and PSTN   | 27          |
| 1.11:                | PLC and Fibre Optics                                   | 28          |
| 1.12:                | PLC bypassing the distribution substation              | 29          |
| 1.13:                | Through transformer signalling                         | 30          |
| 2.1:                 | Typical Daily Load Profile                             | 34          |
| 2.2:                 | Relationship between Generation , Supply and Consumers | 39          |
| 2.3:                 | Primary ( 11kV ) Distribution Architecture             | 46          |
| 2.4:                 | Primary / Secondary Distribution Network               | 47          |
| 2.5:                 | Meter read message protocol                            | 50          |
| 2.6:                 | LV Meter read operation                                | 51          |
| 2.7:                 | Use of repeaters                                       | 52          |
| 2.8:                 | Repeater distribution                                  | 53          |
| 2.9:                 | Broadcast message protocol                             | 54          |
| 2.10:                | LV broadcast operation                                 | 55          |
| 2.11:                | Variation in data rate related to number of consumers  | 60          |
| 2.12:                | MV / LV Communications Architecture                    | 61          |

| <b>Figure Number</b> | <b>Title</b>   | <b>Page</b> |
|----------------------|--|-------------|
| 3.1:                 | Transmission Line Model                                    | 70          |
| 3.2:                 | Reflection at Cable Junctions                              | 73          |
| 3.3:                 | Reflections at Transformer                                 | 73          |
| 3.4:                 | Distribution Network                                       | 76          |
| 3.5:                 | Series Capacitor Compensation                              | 82          |
| 3.6:                 | Shunt Capacitor Compensation                               | 83          |
| 3.7:                 | Voltage Regulator  | 84          |
| 3.8:                 | Surge Arrester   | 85          |
| 3.9:                 | Admittance of Consumer installation ( appliances omitted ) | 87          |
| 3.10:                | Admittance of 7kW resistive / inductive load               | 88          |
| 3.11:                | Resonant Load ( Hi Fi )                                    | 90          |
| 3.12:                | Dy11 Transformer Connections                               | 93          |
| 3.13:                | Dy11 Phase Vectors   | 94          |
| 3.14:                | Dy11 Transformer Construction / Winding                    | 95          |
| 3.15:                | Transformer Representation                                 | 96          |
| 3.16:                | Frequency Spectrum of Smooth Spectrum Noise                | 103         |
| 3.17:                | Synchronous Noise  | 104         |
| 3.18:                | Non Synchronous Periodic Noise                             | 105         |
| 4.1:                 | Effect of Encoding and Modulation                          | 114         |
| 4.2:                 | Frequency spectrum of DSBFC                                | 118         |
| 4.3:                 | Frequency spectrum of SSSC                                 | 119         |
| 4.4:                 | Effect of modulation index on frequency spectrum           | 123         |
| 4.5:                 | PAM waveform   | 126         |
| 4.6:                 | PWM waveform   | 127         |
| 4.7:                 | PPM waveform   | 128         |
| 4.8:                 | Spectrum of ASK  | 131         |
| 4.9:                 | Spectrum of binary FSK                                     | 132         |
| 4.10:                | Spectrum of n-array FSK                                    | 134         |
| 4.11:                | Spectrum of PSK  | 135         |



| <b>Figure Number</b> | <b>Title</b>                                       | <b>Page</b> |
|----------------------|--|-------------|
| 4.12:                | Direct Sequence Spread Spectrum                    | 140         |
| 4.13:                | Frequency Hopping Spread Spectrum                  | 141         |
| 4.14:                | Spectra of Frequency Hopping Spread Spectrum       | 142         |
| 4.15:                | Chirp Spread Spectrum                              | 143         |
| 4.16:                | Frequency Spectrum of FH-DS                        | 143         |
| 4.17:                | Trade-offs of different techniques                 | 147         |
| 4.18a:               | Market Preference of Modulation Schemes            | 153         |
| 4.18b:               | Market Preference of Spread Spectrum Variants      | 154         |
| 5.2.1:               | Dyn11 transformer terminals                        | 157         |
| 5.2.2:               | Preliminary Experiment set up                      | 159         |
| 5.2.3:               | Composite plot of all HV to LV transmissions       | 160         |
| 5.2.4:               | Composite plot of all LV to HV transmissions       | 160         |
| 5.2.5:               | Composite plot of HV to LV transmissions           | 161         |
| 5.2.6:               | Composite plot of LV to HV transmissions           | 162         |
| 5.2.7:               | Composite plot of HV to LV transmissions           | 163         |
| 5.2.8:               | Composite plot of LV to HV transmissions           | 163         |
| 5.3.1:               | Preliminary Coupling circuit outline               | 165         |
| 5.3.2:               | LV / MV Coupling Circuit                           | 166         |
| 5.4.1:               | LV Coupling circuit                                | 169         |
| 5.4.2:               | LV Coupling  | 169         |
| 5.4.3:               | LV Coupling circuit frequency response             | 171         |
| 5.4.4:               | MV Coupling circuit                                | 172         |
| 5.4.5:               | MV Coupling circuit frequency response             | 174         |
| 5.5.2:               | Signalling levels                                  | 178         |
| 5.5.3:               | Frequency Response , Phases A8 / B8 to Phase a / n | 179         |
| 5.5.3a:              | Transposed Plot , Phases A8 / B8 to phase a / n    | 180         |
| 5.5.4:               | Frequency Response , Phases A8 / B8 to Phase b / n | 180         |
| 5.5.4a:              | Transposed Plot , Phases A8 / B8 to phase b / n    | 180         |
| 5.5.5:               | Frequency Response , Phases A8 / B8 to Phase c / n | 181         |

| <b>Figure Number</b> | <b>Title</b>  | <b>Page</b> |
|----------------------|---|-------------|
| 5.5.5a:              | Transposed Plot , Phases A8 / B8 to phase c / n           | 181         |
| 5.5.6:               | Composite plot of HV to LV attenuation                    | 182         |
| 5.5.7:               | HV to LV ( phase/phase to phase/neutral ) pass bands      | 182         |
| 5.5.8:               | Phase a/n to phases A8/B8                                 | 183         |
| 5.5.9:               | Phase a/n to phases A8/C8                                 | 183         |
| 5.5.10:              | Phase a/n to phases B8/C8                                 | 183         |
| 5.5.11:              | Composite plot of LV to HV Pass bands                     | 184         |
| 5.5.12:              | Unenergised Phase / Tank to Phase / Tank , Pass bands     | 186         |
| 5.5.13:              | Unenergised Phase / Phase to Phase / Neutral , Pass bands | 187         |
| 5.5.14:              | Unenergised Phase / Phase to Phase / Phase , Pass bands   | 188         |
| 5.5.15:              | Phase / Tank Signalling                                   | 189         |
| 5.5.16:              | Phase / Neutral Signalling                                | 190         |
| 5.5.17:              | Transformer phases , physical separation                  | 191         |
| 5.5.18a:             | Transformer Dynamic Range ( HV to LV , Unenergised )      | 195         |
| 5.5.18b:             | Transformer Dynamic Range ( LV to HV , unenergised )      | 196         |
| 5.5.19:              | Energised Test set up                                     | 198         |
| 5.5.20:              | Energised Phase / Tank to Phase / Tank , Pass bands       | 200         |
| 5.5.21:              | Energised Phase / Phase to Phase / Neutral , Pass bands   | 201         |
| 5.5.22:              | Energised Phase / Phase to Phase / Phase , Pass bands     | 202         |
| 5.5.24a:             | Transformer Dynamic Range ( HV to LV , Energised )        | 205         |
| 5.5.24b:             | Transformer Dynamic Range ( LV to HV , Energised )        | 206         |
| 5.5.25:              | High and Low pass filter action                           | 208         |
| 5.5.26:              | Phases A8 / B8 to Phases a / b ( Energised )              | 209         |
| 5.5.27:              | Phases A8 / B8 to Phases a / b ( Unenergised )            | 210         |
| 5.5.28:              | Composite plot of Energised and Unenergised response      | 210         |
| 5.5.29:              | Frequency Hopping System                                  | 212         |
| 5.5.30:              | Compressed output of dispersive filter                    | 215         |
| 5.5.31:              | Intellon Swept Carrier                                    | 218         |
| 5.5.32:              | Observation of Intellon Sequence                          | 219         |

| <b>Figure Number</b> | <b>Title</b>  | <b>Page</b> |
|----------------------|---|-------------|
| 5.5.33:              | Intellon System Set up                                | 220         |
| 5.5.34:              | Chirp Sequence ( passed through transformer )         | 221         |
| 5.5.35:              | Expanded plot ( phases a / n to phases A8 / B8 )      | 222         |
| 5.5.36:              | Attenuation versus Bandwidth & Data Rate              | 225         |
| 5.5.37:              | Direct Sequence System                                | 228         |
| 5.5.38:              | Code Sequence G (c)                                   | 228         |
| 5.5.39:              | $\left(\frac{\sin x}{x}\right)^2$ power spectrum      | 229         |
| 5.5.40:              | Main Lobe Bandwidth                                   | 230         |
| 5.5.41:              | Correlator Degradation                                | 231         |
| 5.5.42:              | Transformer Phase Characteristics                     | 232         |
| 5.5.43:              | Transformer Attenuation Versus Data Rate ( 80kHz BW ) | 235         |
| 5.5.44:              | Data Rate of Different Bandwidths vs Attenuation      | 237         |
| 6.1:                 | Through Transformer Architecture                      | 240         |
| 6.2:                 | Transformer Symmetry                                  | 246         |

| <b>Table Number</b> | <b>Title</b>                          | <b>Page</b> |
|---------------------|---------------------------------------|-------------|
| 2.1:                | LV Data rate summary                  | 60          |
| 2.2:                | Network Statistics                    | 63          |
| 2.3:                | MV data rate summary                  | 66          |
| 2.4:                | Through Transformer Data Rates        | 67          |
| 3.1:                | Frequency Bands                       | 70          |
| 3.2:                | Cable Characteristic Impedance        | 77-79       |
| 3.3:                | Cable Attenuation                     | 81-82       |
| 3.4:                | Resonant Loads                        | 89          |
| 3.5.a:              | Thorn EMI Transformer Impedance       | 97          |
| 3.5.b:              | Impedance Measurements by Schroppel   | 97          |
| 3.6.a:              | Thorn EMI Transformer Attenuation     | 98          |
| 3.6.b:              | Attenuation Measurements by Schroppel | 99          |
| 3.7:                | Network Impedances                    | 100         |

| <b>Table Number</b> | <b>Title</b>                                 | <b>Page</b> |
|---------------------|--|-------------|
| 3.8:                | MV network noise levels                      | 103         |
| 3.9:                | Sources and levels of Noise                  | 106         |
| 3.10:               | Network Attenuation Levels                   | 108-110     |
| 4.1:                | FSK Modulation Schemes                       | 133         |
| 4.2:                | Spread Spectrum Modulation Systems           | 145         |
| 5.5.1:              | SNR for 1 in $10^4$ BER                      | 176         |
| 5.5.2:              | Transformers / Signalling modes investigated | 184         |
| 5.5.3               | Transformer Dynamic Range                    | 194-195     |
| 5.5.4:              | Transformer Dynamic Range ( Energised )      | 204-205     |
| 5.5.5:              | Usable Transformer Bandwidth                 | 214         |
| 5.5.6:              | Chirp Carrier Attenuation                    | 221         |
| 5.5.7:              | Attenuation versus Bandwidth & Data Rate     | 224         |
| 5.5.8:              | Data Rate Versus Attenuation                 | 234         |
| 5.5.9:              | Data Rate Versus Attenuation and BW          | 236         |

# **Abbreviations and Symbols**

## **Abbreviations**

Low Voltage ( LV )

Medium Voltage ( MV )

High Voltage ( HV )

direct current ( d.c )

alternating current ( a.c )

Central Electricity Generating Board ( CEGB )

Office of Electricity Regulation ( OFFER )

Power Line Carrier ( PLC )

Public Switched Telephone Network ( PSTN )

Very Large Scale Integration ( VLSI )

Remote Terminal Unit ( RTU )

Electricity Supply Industry ( ESI )

Consumer Electronic Bus ( CEBus )

National Grid Company ( NGC )

Liquid Crystal Display ( LCD )

Beama Metering Association ( BMA )

European Committee for Electrotechnical standardisation ( CENELEC )

Standing Wave Ratio ( SWR )

United Kingdom ( UK )

Silicon Controlled Rectifier ( SCR )

Signal to Noise Ratio ( SNR )

Amplitude Modulation ( AM )

Alternate Mark Inversion ( AMI )

Double Sideband Full Carrier ( DSBFC )

Single Sideband Suppressed Carrier ( SSSC )

High Frequency ( HF )

Frequency Modulation ( FM )

**Phase Modulation ( PM )**  
**Pulse Amplitude Modulation ( PAM )**  
**Pulse Time Modulation ( PTM )**  
**Pulse Width modulation ( PWM )**  
**Pulse Position modulation ( PPM )**  
**Pulse Code Modulation ( PCM )**  
**Differential Pulse Code Modulation ( DPCM )**  
**Amplitude Shift Keying ( ASK )**  
**On Off Keying ( OOK )**  
**Binary Amplitude Shift Keying ( BASK )**  
**Frequency Shift Keying ( FSK )**  
**Binary Frequency Shift Keying ( BFSK )**  
**Spread Frequency Shift Keying ( S-FSK )**  
**Phase Shift Keying ( PSK )**  
**Binary Phase Shift Keying ( BPSK )**  
**Differential Phase Shift Keying ( DPSK )**  
**Quadrature Phase Shift Keying ( QPSK )**  
**Quadrature Amplitude Modulation ( QAM )**  
**Federal Communications Commission ( FCC )**  
**Industrial Scientific Medical ( ISM )**  
**Direct Sequence Spread Spectrum ( DS-SS )**  
**Frequency Hopping Spread Spectrum ( FH-SS )**  
**Pseudo Noise ( PN )**  
**Frequency Hopped Direct Sequence ( FH-DS )**  
**Two Way Automatic Communication System ( TWACS )**  
**Regional Electricity Company ( REC )**  
**Bit Error Rate ( BER )**  
**International Electrotechnical Commission ( IEC )**  
**Automatic Meter Reading Association ( AMRA )**  
**Bits Per Second ( bps )**

## Units and Symbols

| Quantity                     | Symbol    | Abbreviation | Units         |
|------------------------------|-----------|--------------|---------------|
| Electromotive Force          | $V$       | V            | Volts         |
| Current                      | $I$       | A            | Ampres        |
| Resistance                   | $R$       | $\Omega$     | Ohms          |
| Inductance ( Self )          | $L$       | H            | Henrys        |
| Conductance                  | $G$       | S            | Siemens       |
| Admittance                   | $Y$       | S            | Siemens       |
| Capacitance                  | $C$       | F            | Farrads       |
| Velocity ( Angular )         | $\omega$  | Rads         | Radians / Sec |
| Impedance                    | $Z$       | $\Omega$     | Ohms          |
| Impedance ( Characteristic ) | $Z_c$     | $\Omega$     | Ohms          |
| Power ( Active )             | $P$       | W            | Watts         |
| Power ( apparent )           | $S$       | VA           | Volt Ampres   |
| Wavelength                   | $\lambda$ | $\lambda$    | metres        |
| Attenuation                  | $A$       | dB           | decibells     |
| Frequency                    | $f$       | Hz           | Hertz         |
| Q factor                     | $Q$       | Q            | *****         |
| Phase angle                  | $\Phi$    | Rads         | Radians       |
| Bandwidth                    | $B$       | B            | Hertz         |
| Time                         | $t$       | Sec          | Seconds       |
| Length                       | $l$       | m            | metres        |

## Multipliers

| Quantity | Symbol | Units      |
|----------|--------|------------|
| Giga     | G      | $10^9$     |
| Mega     | M      | $10^6$     |
| Kilo     | k      | $10^3$     |
| hecto    | h      | $10^2$     |
| deca     | da     | $10^1$     |
| deci     | d      | $10^{-1}$  |
| centi    | c      | $10^{-2}$  |
| milli    | m      | $10^{-3}$  |
| micro    | $\mu$  | $10^{-6}$  |
| nano     | n      | $10^{-9}$  |
| pico     | p      | $10^{-12}$ |
| femto    | f      | $10^{-15}$ |



## **Appendix A: 50 KVA Transformer Frequency Characteristics**

**Phase/Tank mode Signalling:**

**MR (B2): 435.60Hz**  
**A(\*)MAG 1.98dB 5dB/ -14.20dB**

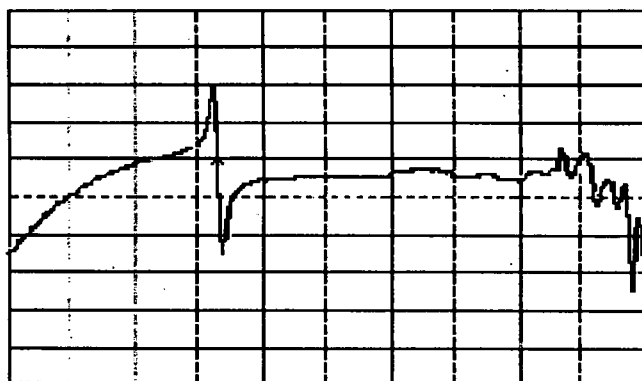

**LOG START: 10Hz**                      **LOG STOP: 1MHz**  
**OUT(B): 0.00dBn**                      **ST: AUTO x1**                      **1Hz**  
**RES: 20dBn**                      **RBW: 30kHz**                      **VBW: 30kHz**

Fig A1: Phase A8 / Tank to phase a / Tank ( Phase/Tank mode ) .

**MR (211): 165 600.00Hz**  
**A(\*)MAG 2.40dB 5dB/ -14.70dB**

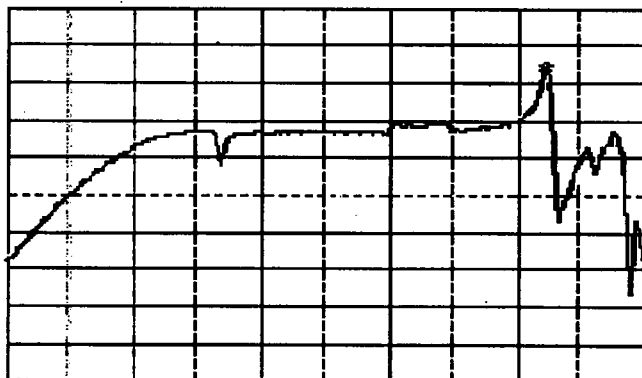

**LOG START: 10Hz**                      **LOG STOP: 1MHz**  
**OUT(B): 0.00dBn**                      **ST: AUTO x1**                      **1Hz**  
**RES: 20dBn**                      **RBW: 30kHz**                      **VBW: 30kHz**

Fig A2: Phase a / Tank to phase A8 / Tank ( Phase/Tank mode ) .

# Phase/Neutral Mode Signalling:

**IR:K160): 15 820.00Hz**  
**A(φ): MAG -39.85dB 5dB/ -39.20dB**

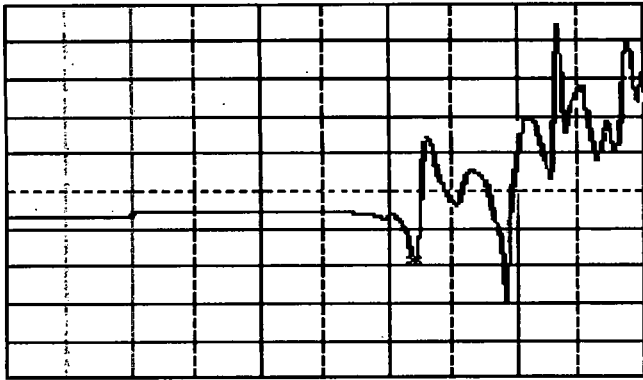

**LOG START: 10Hz LOG STOP: 1MHz**  
**OUT(B): 0.00dBn ST: AUTO x1 1Hz**  
**REF: 20dBn RBW: 30kHz VBW: 30kHz**

Fig A3: Phase A8 / B8 to Phase a / n ( Phase / Neutral signalling ) .

**IR:K160): 15 820.00Hz**  
**A(φ): MAG -7.23dB 5dB/ -3.20dB**

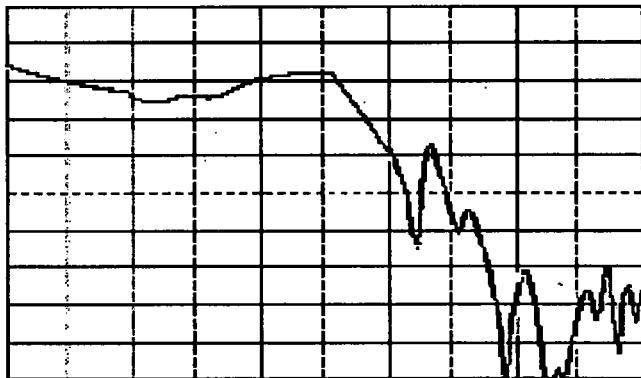

**LOG START: 10Hz LOG STOP: 1MHz**  
**OUT(B): 0.00dBn ST: AUTO x1 1Hz**  
**REF: 20dBn RBW: 30kHz VBW: 30kHz**

Fig A4: Phase a / n to Phases A8 / B8 ( Phase / Neutral signalling ) .

**MRK(159):15 110.00Hz**  
**A(+):MAG -46.97dB 5dB/ -25.20dB**

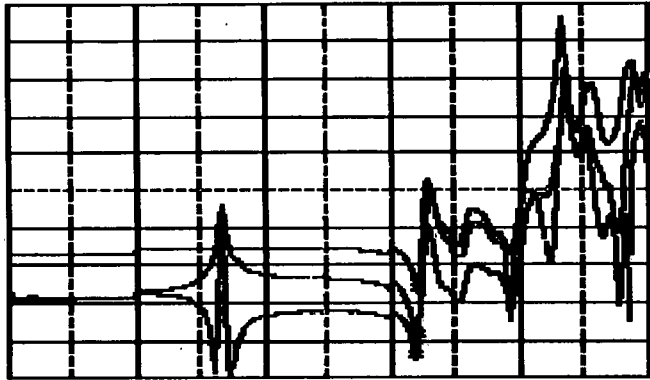

**LOG START: 10Hz LOG STOP: 1MHz**  
**OUT(B): 0.00dBm ST: AUTO x1 1Hz**  
**RES: 20dBm RBW: 30kHz LBW: 30kHz**

Fig A5: HV to LV Composite plot ( Phase / Neutral signalling ) .

**MRK(160):15 820.00Hz**  
**A(+):MAG -7.16dB 5dB/ [REDACTED]**

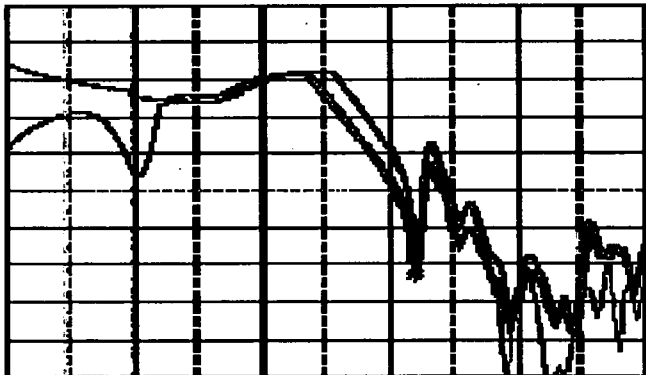

**LOG START: 10Hz LOG STOP: 1MHz**  
**OUT(B): 0.00dBm ST: AUTO x1 1Hz**  
**RES: 20dBm RBW: 30kHz LBW: 30kHz**

Fig A6: LV to HV Composite plot ( Phase / Neutral signalling ) .

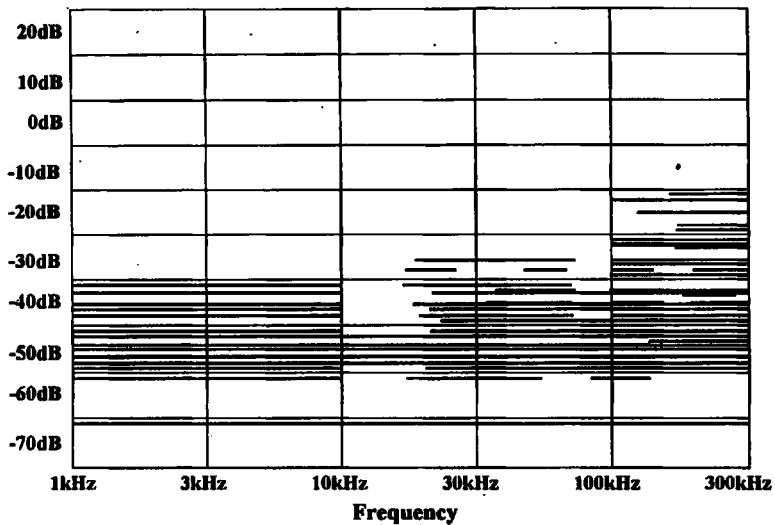

Fig A7: Transposed Composite Pass bands , HV to LV ( Phase / Neutral signalling ).

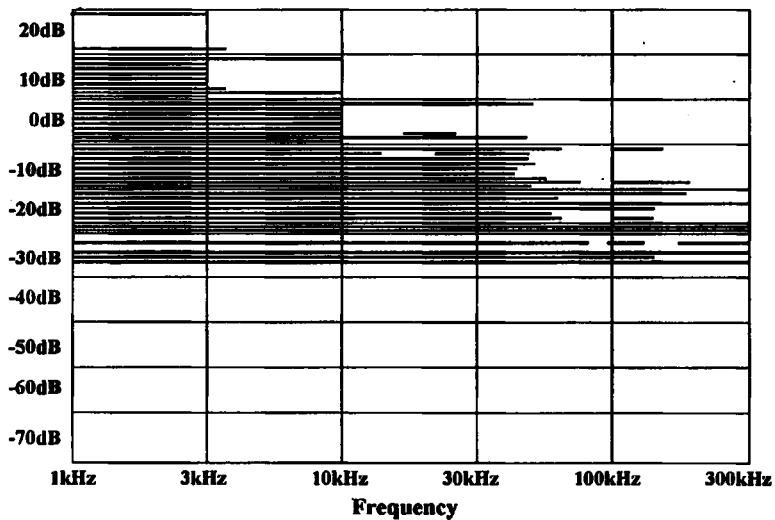
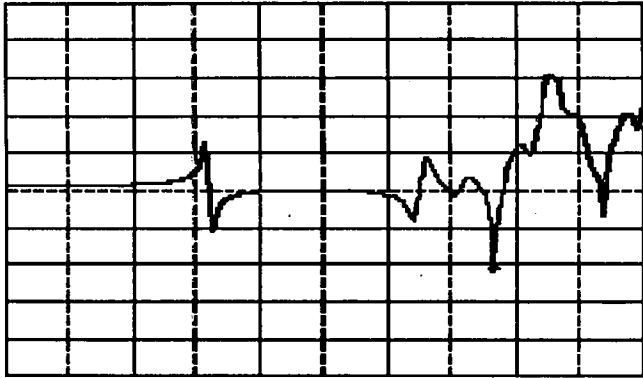

Fig A8: Transposed Composite Pass bands , LV to HV ( Phase / Neutral signalling ).

**Phase / Phase Mode Signalling:**

**REF (191): 65 960.00Hz**  
**A(+): MAG -58.79dB 10dB/ -39.00dB**



**LOG START: 10Hz**                      **LOG STOP: 1MHz**  
**OUT(B): 0.00dBm**                      **ST: AUTO x1**                      **1Hz**  
**IRG: 10dBm**                      **RBW: 30kHz**                      **VBW: 30kHz**

Fig A9: Phases A8 / B8 to Phases a / b ( Phase / Phase signalling ) .

**REF (191): 65 960.00Hz**  
**A(+): MAG -36.87dB 10dB/ -39.00dB**

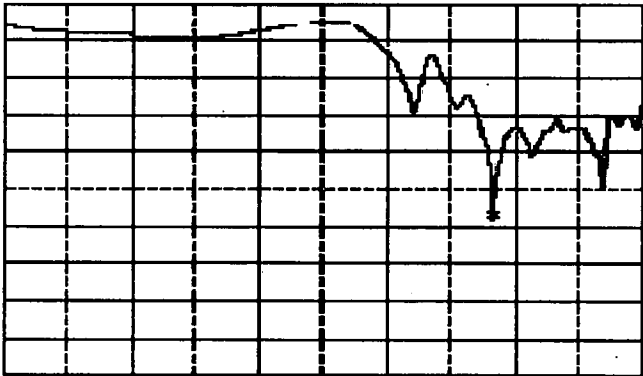

**LOG START: 10Hz**                      **LOG STOP: 1MHz**  
**OUT(B): 0.00dBm**                      **ST: AUTO x1**                      **1Hz**  
**IRG: 20dBm**                      **RBW: 30kHz**                      **VBW: 30kHz**

Fig A10: Phases a / b to Phases A8 / B8 ( Phase / Phase signalling ) .

152(192):69 070.00Hz  
A(+):MAG -47.52dB 10dB/ -30.00dB

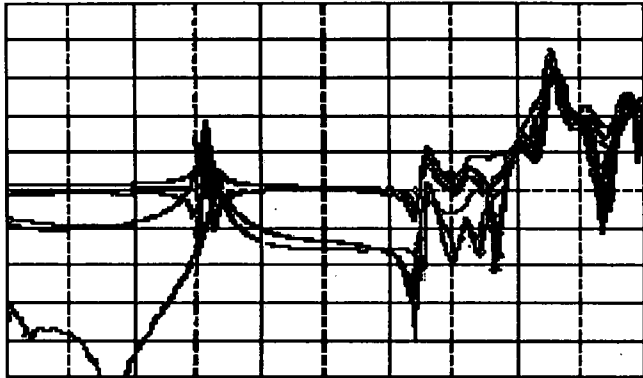

LOG STEP: 10Hz LOG STOP: 1MHz  
OUT(B): 0.00dBm ST: AUTO x1 1Hz  
IRG: 20dBm RBW: 30kHz VBW: 30kHz

Fig A11: HV to LV Composite plot ( Phase / Phase signalling ).

152(193):72 330.00Hz  
A(+):MAG -35.25dB 10dB/ -30.00dB

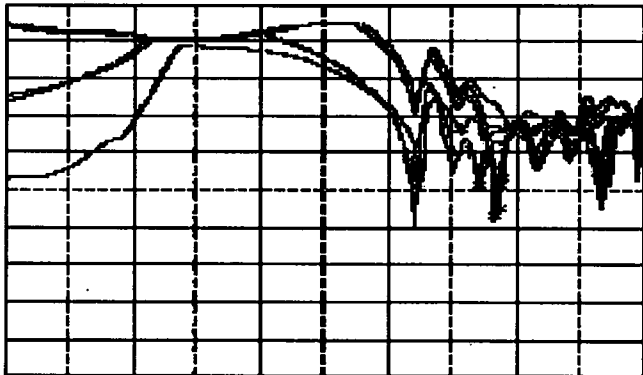

LOG STEP: 10Hz LOG STOP: 1MHz  
OUT(B): 0.00dBm ST: AUTO x1 1Hz  
IRG: 20dBm RBW: 30kHz VBW: 30kHz

Fig A12: LV to HV Composite plot ( Phase / Phase signalling ).

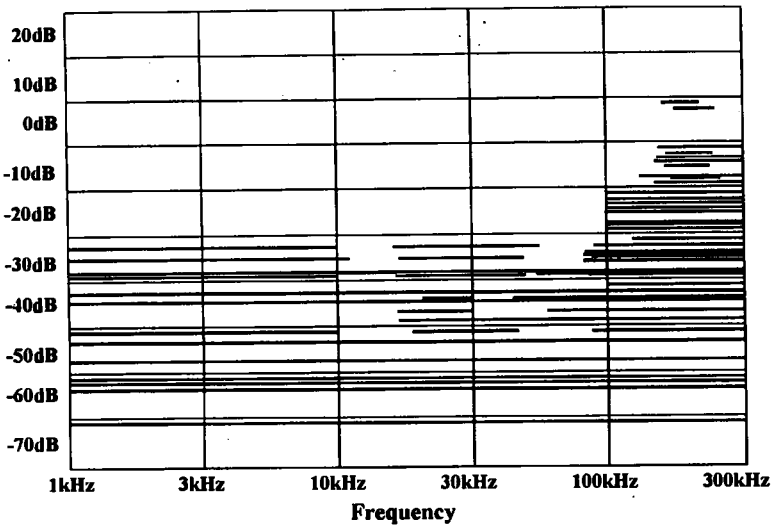

Fig A13: Transposed Composite Pass bands , HV to LV ( Phase / Phase signalling ) .

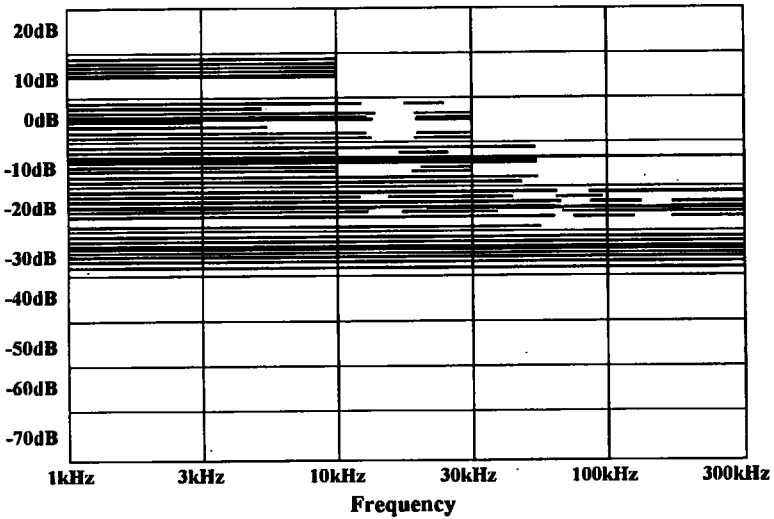

Fig A14: Transposed Composite Pass bands , LV to HV ( Phase / Phase signalling ) .



## **Appendix B: Transformer Frequency Characteristics**

**( A 'Cross section' of unenergised plots )**

1000KVA Transformer:

REF(183): 45 620.00Hz  
 A(\*): MAG -12.05dB 10dB/ -30.00dB

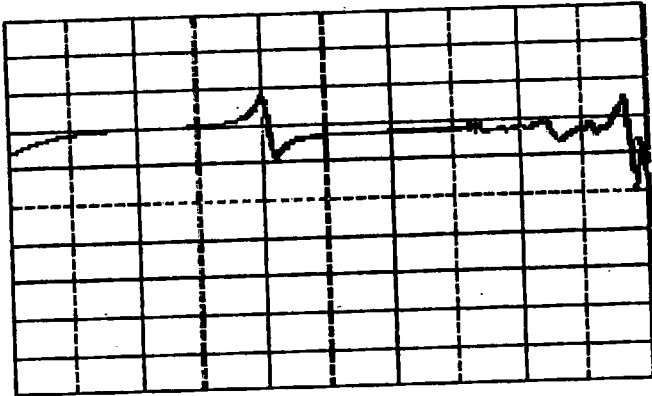

LOG START: 10Hz LOG STOP: 1MHz  
 OUT(B): 0.00dBm ST: AUTO x1 1Hz  
 IRG: 20dBm RBW: 30kHz VBW: 30kHz

Fig B1: HV to LV Composite plot ( Phase / Tank signalling ).

REF(183): 45 620.00Hz  
 A(\*): MAG -8.00dB -30.00dB

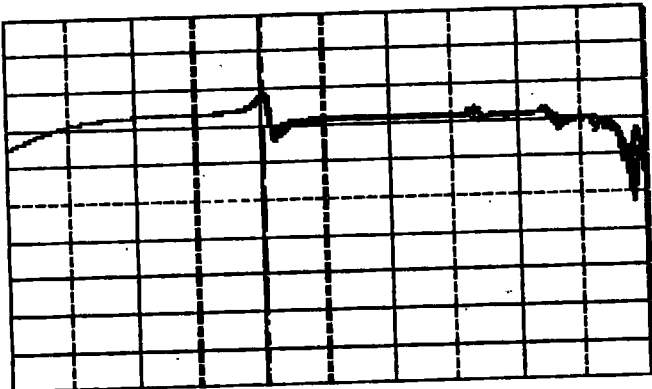

LOG START: 10Hz LOG STOP: 1MHz  
 OUT(B): 0.00dBm ST: AUTO x1 1Hz  
 IRG: 20dBm RBW: 30kHz VBW: 30kHz

Fig B2: LV to HV Composite plot ( Phase / Tank signalling ).

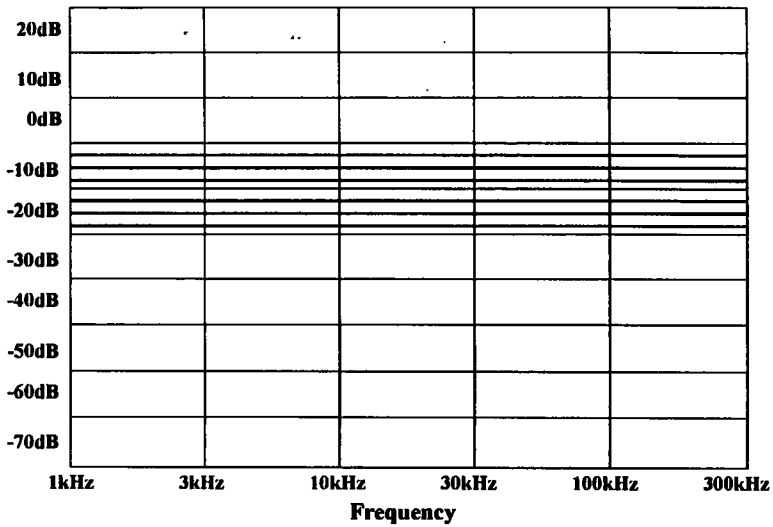

Fig B3: Transposed Composite Pass bands , HV to LV ( Phase / Tank signalling ) .

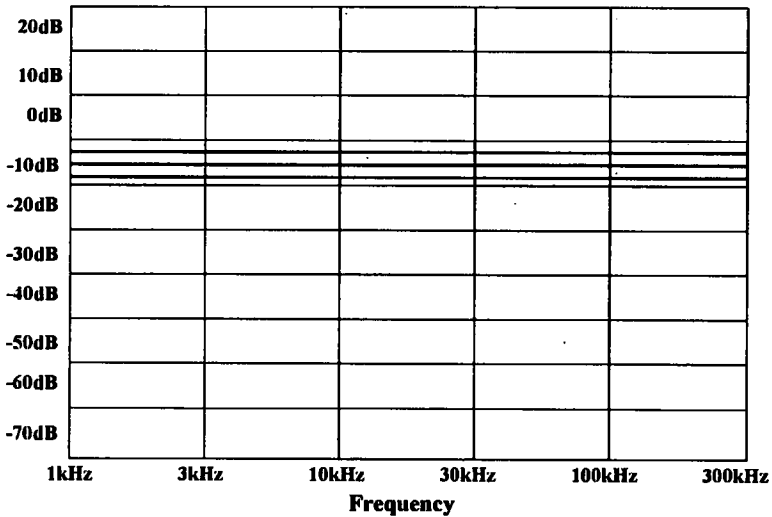
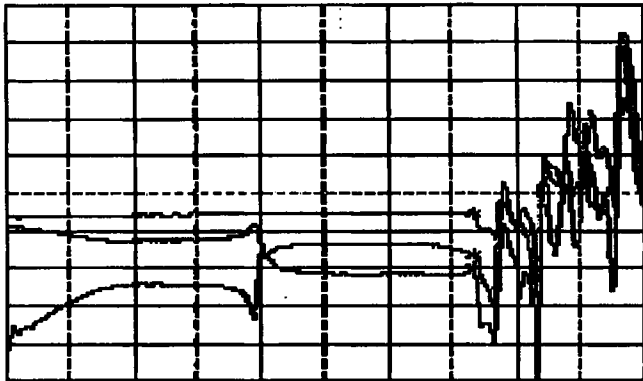

Fig B4: Transposed Composite Pass bands , LV to HV ( Phase / Tank signalling ) .

(183):45 620.00Hz  
 A(\*):MAG -30.00dB -30.00dB



LOG START: 10Hz LOG STOP: 1MHz  
 OUT(B): 0.00dBn ST: AUTO x1 1Hz  
 IRG: 20dBn RBW: 30kHz VBW: 30kHz

Fig B5: HV to LV Composite plot ( Phase / Neutral signalling )

(183):45 620.00Hz  
 A(\*):MAG -20.00dB -30.00dB



LOG START: 10Hz LOG STOP: 1MHz  
 OUT(B): 0.00dBn ST: AUTO x1 1Hz  
 IRG: 20dBn RBW: 30kHz VBW: 30kHz

Fig B6: LV to HV Composite plot ( Phase / Neutral signalling )

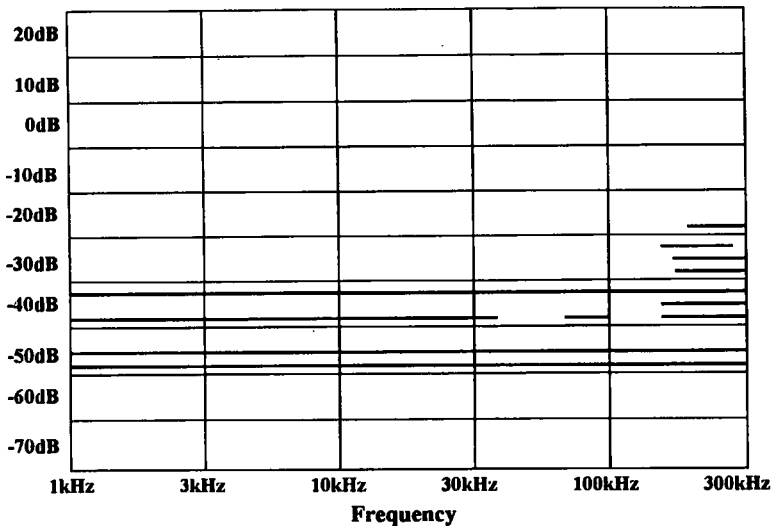

Fig B7: Transposed Composite Pass bands , HV to LV ( Phase / Neutral signalling ) .

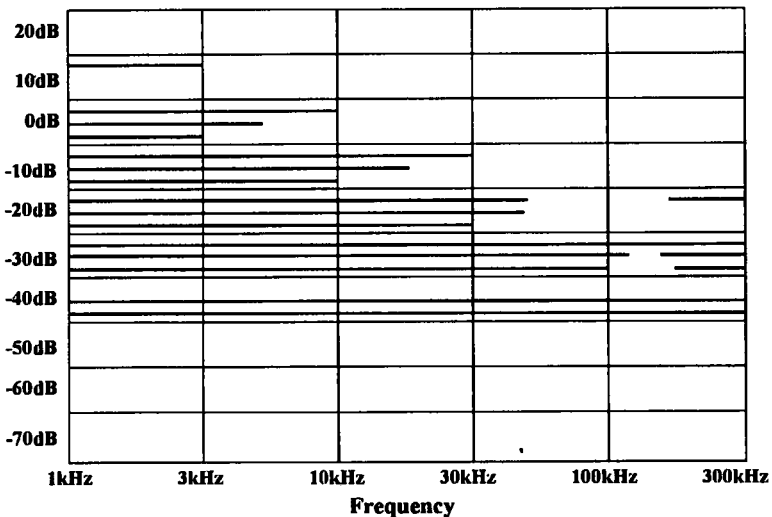
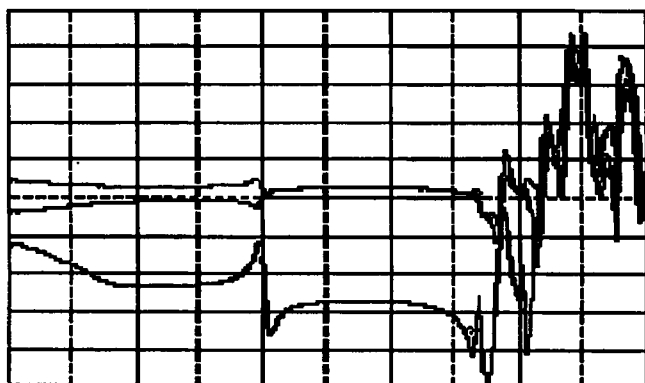

Fig B8: Transposed Composite Pass bands , LV to HV ( Phase / Neutral signalling ) .

REF(183):45 620.00Hz  
R(\*):MAG -47.54dB 5dB/ -30.20dB



LOG START: 10Hz LOG STOP: 1MHz  
OUT(B): 0.00dBm ST: AUTO x1 1Hz  
IRG: 20dBm RBW: 30kHz UBW: 30kHz

Fig B9: HV to LV Composite plot ( Phase / Phase signalling ).

REF(183):45 620.00Hz  
R(\*):NRG -13.22dB 10dB/ -30.20dB

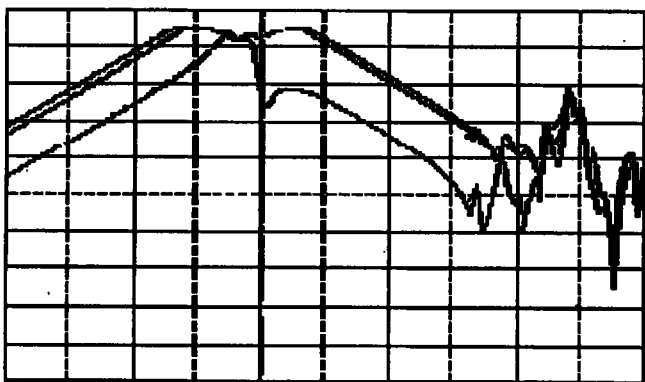

LOG START: 10Hz LOG STOP: 1MHz  
OUT(B): 0.00dBm ST: AUTO x1 1Hz  
IRG: 20dBm RBW: 30kHz UBW: 30kHz

Fig B10: LV to HV Composite plot ( Phase / Phase signalling ).

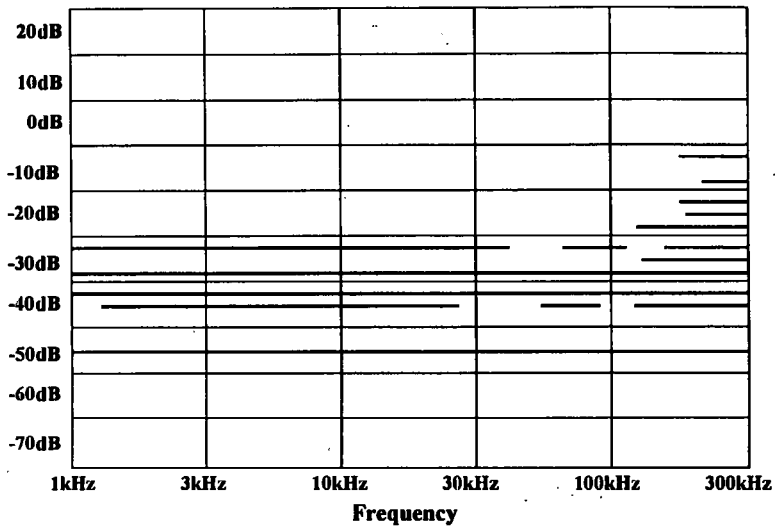

Fig B11: Transposed Composite Pass bands , HV to LV ( Phase / Phase signalling ) .

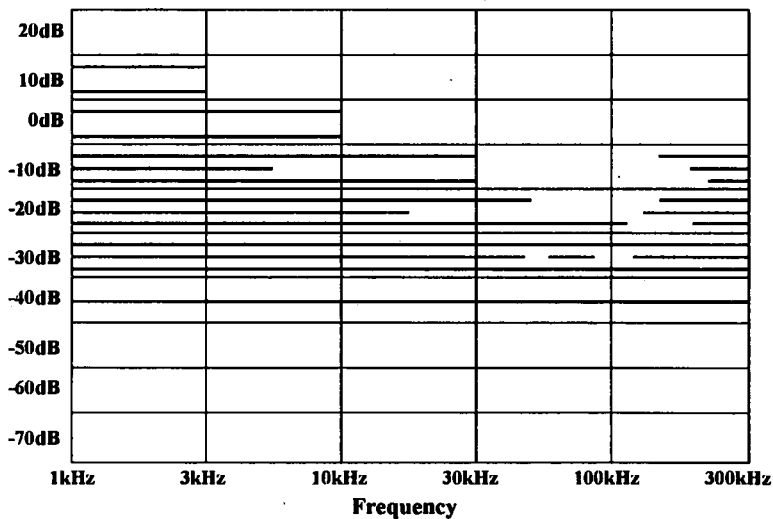
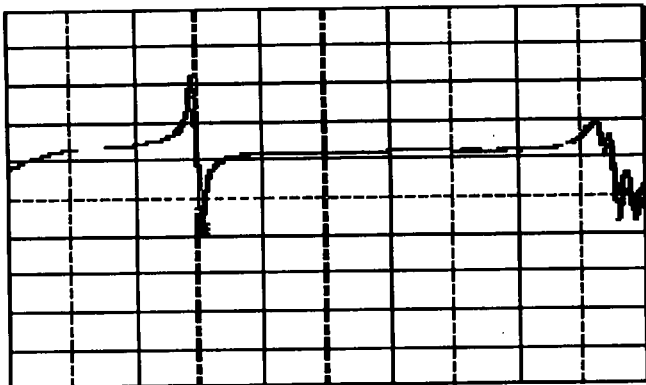

Fig B12: Transposed Composite Pass bands , LV to HV ( Phase / Phase signalling ) .

400KVA Transformer:

MRX( 76):330.40Hz  
 AC\*:MAG -33.91dB 10dB/ -25.00dB



LOG START:10Hz LOG STOP:1MHz  
 OUT(B):0.00dBm  AUTO x1 1Hz  
 IRG:20dBm RBW:30kHz USB:30kHz

Fig B13: HV to LV Composite plot ( Phase / Tank signalling ) .

MRX( 74):301.30Hz  
 AC\*:MAG 1.80dB 10dB/ -25.00dB

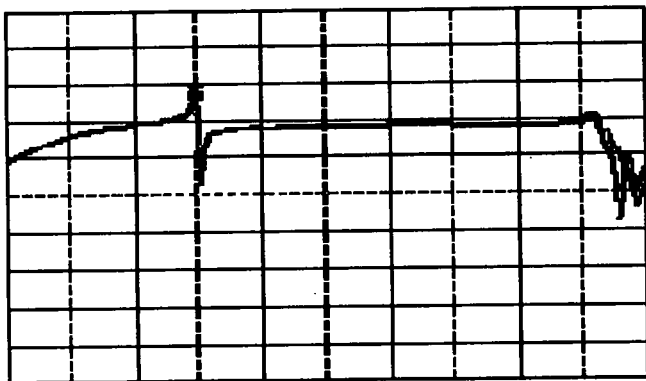

LOG START:10Hz LOG STOP:1MHz  
 OUT(B):0.00dBm  AUTO x1 1Hz  
 IRG:20dBm RBW:30kHz USB:30kHz

Fig B14: LV to HV Composite plot ( Phase / Tank signalling ) .



MRK(196):83 800.00Hz  
 AC\*:MAG -38.76dB 10dB/ -20.00dB

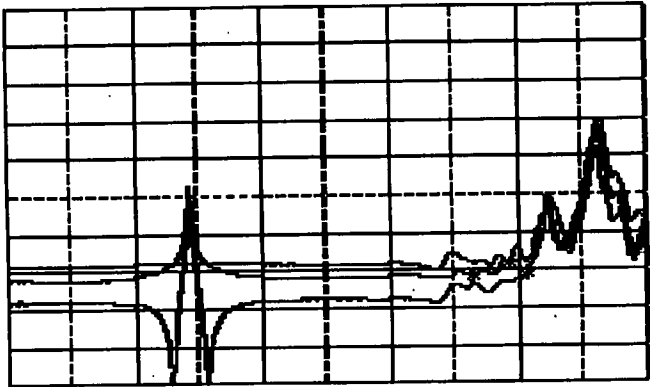

LOG START:10Hz LOG STOP:1MHz  
 OUT(B):0.00dBm AUTO x1 1Hz  
 IRG:20dBm RBW:30kHz USB:30kHz

Fig B15: HV to LV Composite plot ( Phase / Neutral signalling ).

MRK(203):114 700.00Hz  
 AC\*:MAG -28.16dB 10dB/ -20.00dB

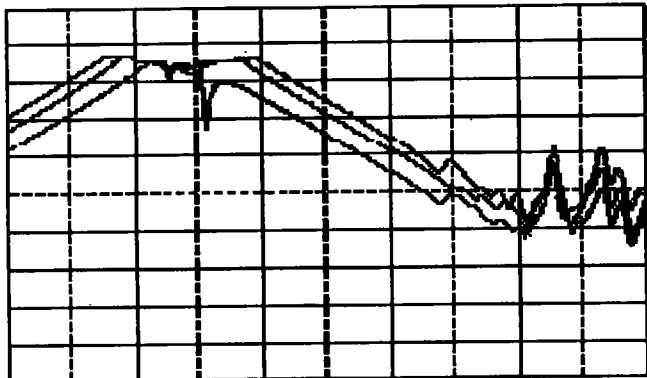

LOG START:10Hz LOG STOP:1MHz  
 OUT(B):0.00dBm AUTO x1 1Hz  
 IRG:20dBm RBW:30kHz USB:30kHz

Fig B16: LV to HV Composite plot ( Phase / Neutral signalling ).

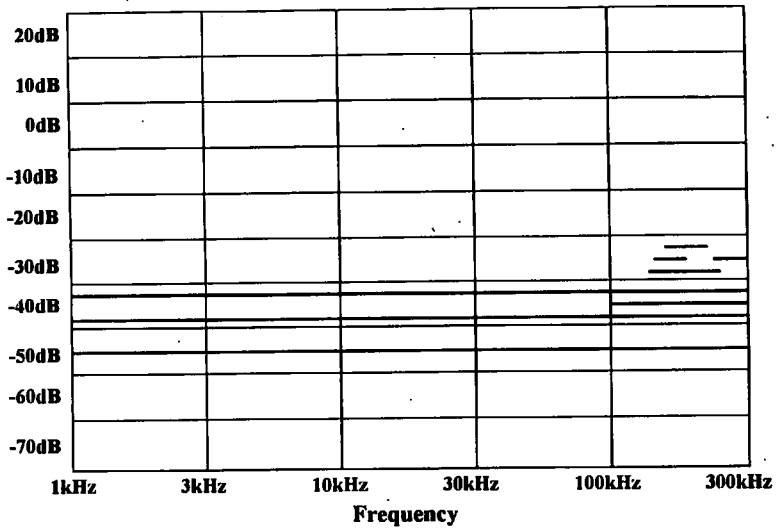

Fig B17: Transposed Composite Pass bands , HV to LV ( Phase / Neutral signalling ) .

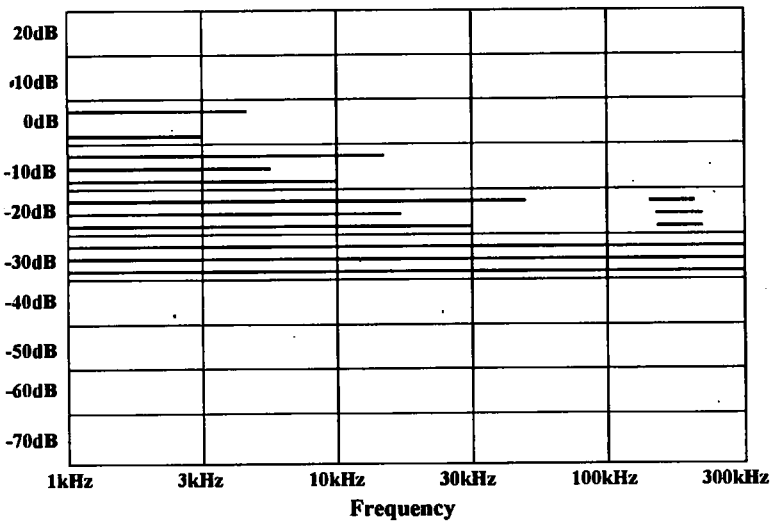
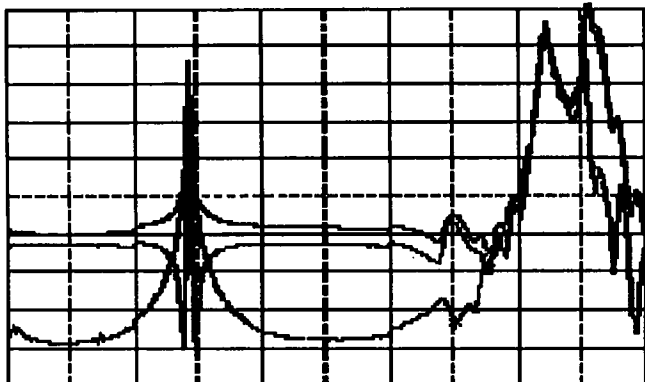

Fig B18: Transposed Composite Pass bands , LV to HV ( Phase / Neutral signalling ) .

**TRK(188):57** 446.68Hz |  
**R(\*):MAG** -39.93dB 5dB/ -30.00dB



**LOG START:10Hz** **LOG STOP:1MHz**  
**OUT(B):0.00dBm** **EAUTO x1** **1Hz**  
**IRG:20dBm** **RBW:30kHz** **VBW:30kHz**

Fig B19: HV to LV Composite plot ( Phase / Phase signalling ).

**TRK(195):79** 336.68Hz  
**R(\*):MAG** -24.17dB 10dB/ -20.50dB

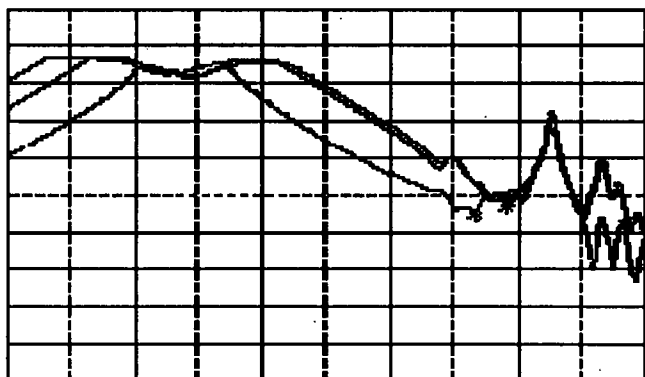

**LOG START:10Hz** **LOG STOP:1MHz**  
**OUT(B):0.00dBm** **EAUTO x1** **1Hz**  
**IRG:20dBm** **RBW:30kHz** **VBW:30kHz**

Fig B20: LV to HV Composite plot ( Phase / Phase signalling ).

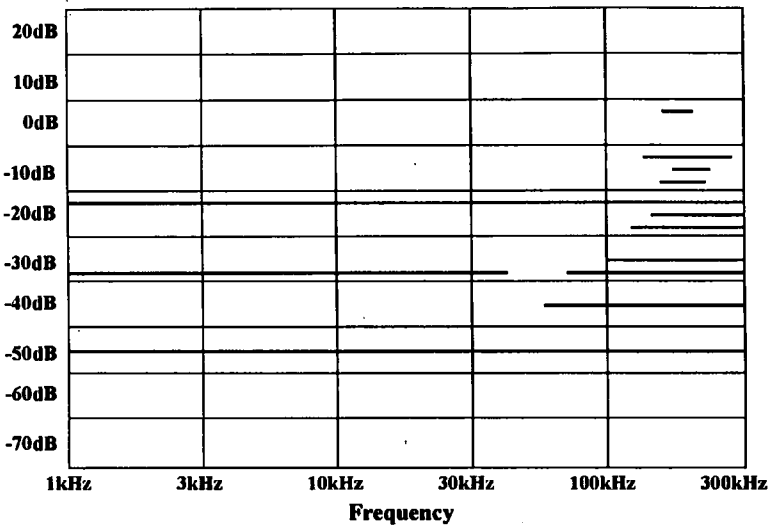

Fig B21: Transposed Composite Pass bands , HV to LV ( Phase / Phase signalling ) .

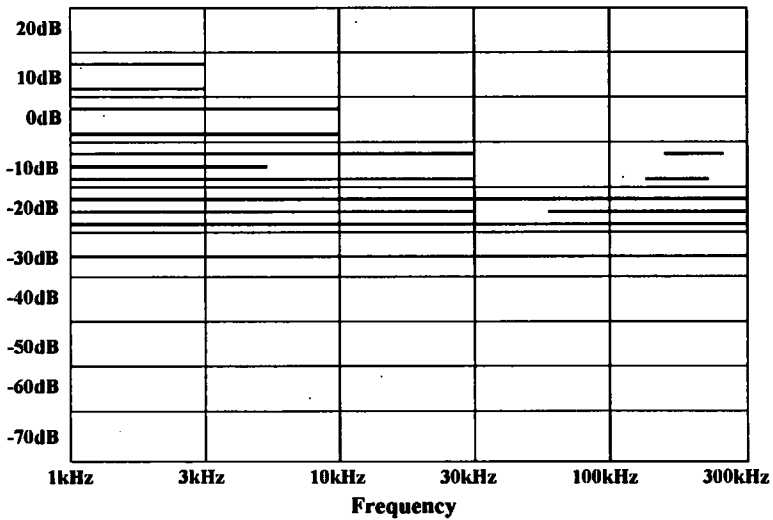
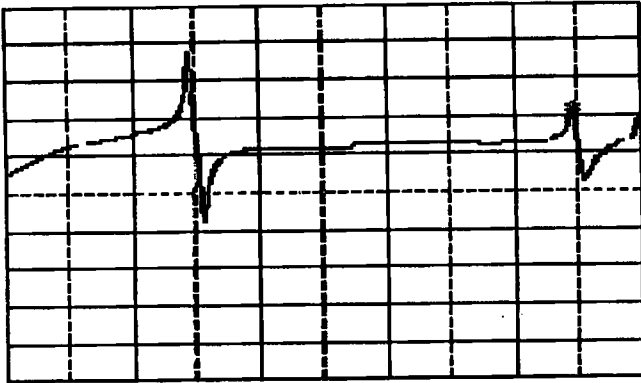

Fig B22: Transposed Composite Pass bands , LV to HV ( Phase / Phase signalling ) .

**25KVA Single Phase Transformer:**

**TRK(223):287.709.68Hz**  
**A(\*) :MAG -8.48dB 10dB/ -30.40dB**



**LOG START: 10Hz LOG STOP: 1MHz**  
**OUT(B): 0.00dBm  AUTO x1 1Hz**  
**IRG: 20dBm RBW: 30kHz USB: 30kHz**

Fig B23: Phase A1 / Tank to Phase a / Tank ( Phase / Tank signalling ,HV to LV ) .

**TRK( 74 ):301.30Hz**  
**A(\*) :MAG 8.16dB 10dB/ -30.40dB**

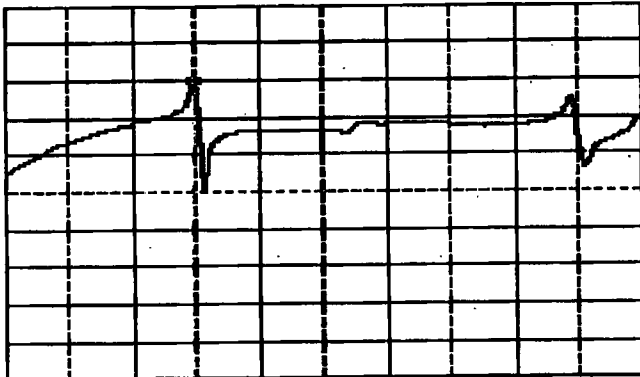

**LOG START: 10Hz LOG STOP: 1MHz**  
**OUT(B): 0.00dBm  AUTO x1 1Hz**  
**IRG: 20dBm RBW: 30kHz USB: 30kHz**

Fig B24: Phase a / Tank to Phase A1 / Tank ( Phase / Tank signalling , LV to HV ) .

MRK(214):190 100.00Hz  
A(\*):MAG -0.63dB 10dB/ -30.40dB

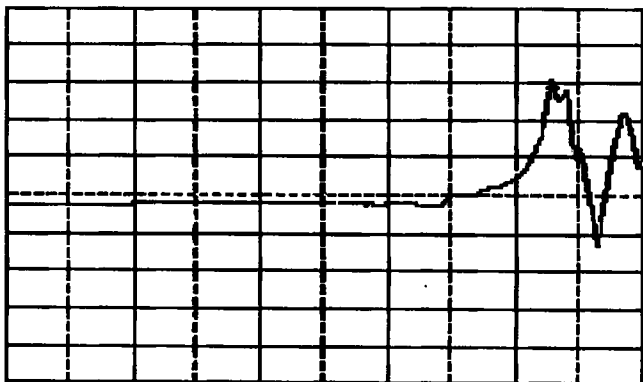

LOG START:10Hz LOG STOP:1MHz  
OUT(B):0.00dBm  AUTO x1 1Hz  
IRG:20dBm RBW:30kHz USB:30kHz

Fig B25: Phases A1 / A2 to Phases a1 / a2 (Phase / 'neutral' signalling , HV to LV).

MRK(214):190 100.00Hz  
A(\*):MAG -16.44dB 10dB/ -30.40dB

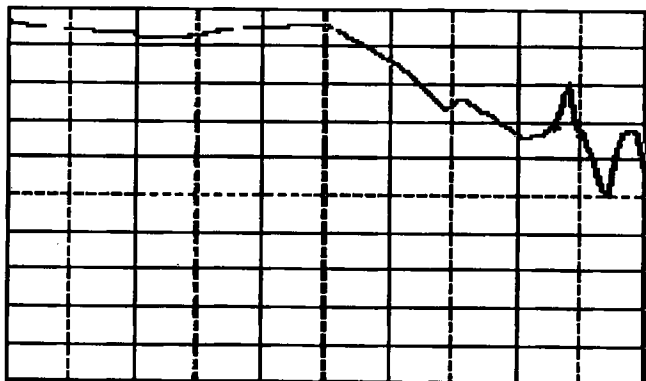

LOG START:10Hz LOG STOP:1MHz  
OUT(B):0.00dBm  AUTO x1 1Hz  
IRG:20dBm RBW:30kHz USB:30kHz

Fig B26: Phases a4/a2 / a3/a1 to Phases A1/A2  
( Parallel , phase/'neutral' mode , LV to HV).

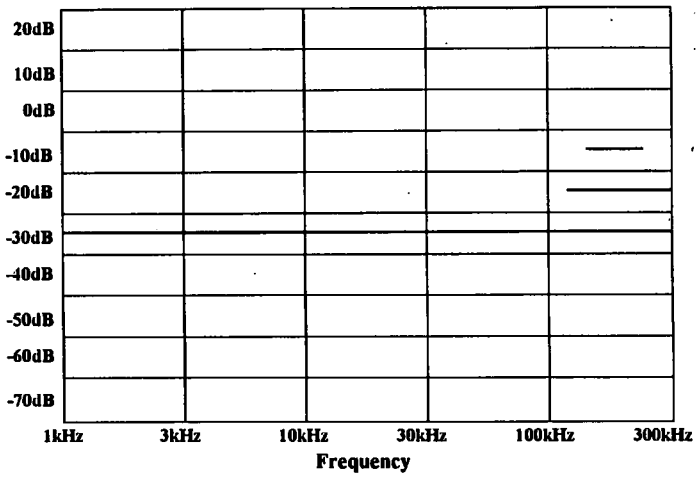

Fig B27: Transposed Passbands , Phases A1 / A2 to Phases a1 / a2  
 ( Phase / 'neutral' signalling , HV to LV ).

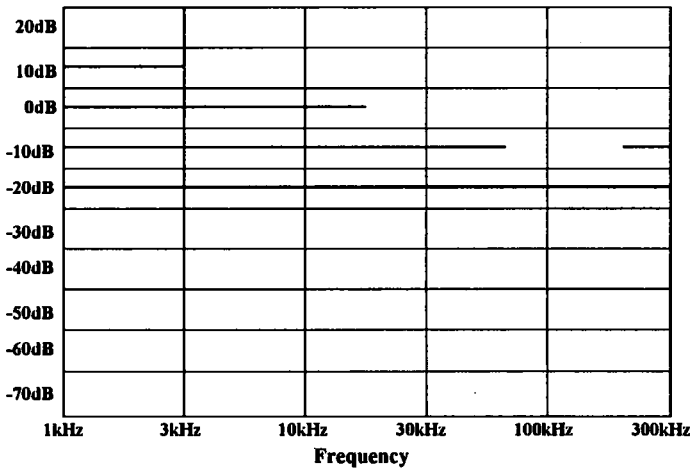
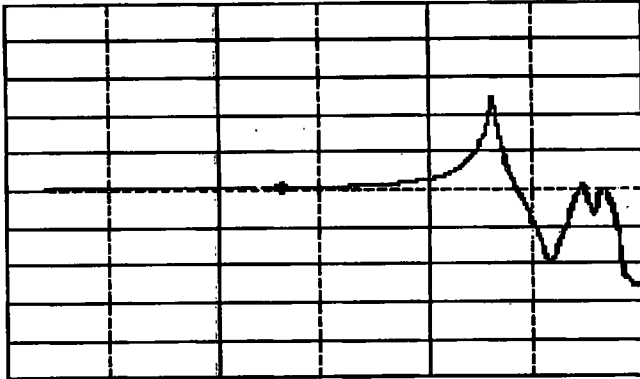

Fig B28: Transposed Passbands , a4/a2 / a3/a1 to Phases A1 / A2  
 ( Parallel , Phase / 'neutral' signalling , LV to HV ).

1600KVA Transformer #1:

**TRF<108>:19 928.00Hz**  
**A(\*):MAG -13.96dB 10dB/ -15.00dB**



**LOG START: 1kHz**                      **LOG STOP: 1MHz**  
**OUT(B): 0.00dBm**                      **ST: AUTO x1**                      **1Me**  
**IRG: 20dBm**                      **RBW: 30kHz**                      **VBW: 30kHz**

Fig B29: Phase A8 / Tank to Phase a / Tank ( Phase / Tank Signalling mode , HV to LV).

**TRF<170>:111 600.00Hz**  
**A(\*):MAG -2.82dB 10dB/ -15.00dB**

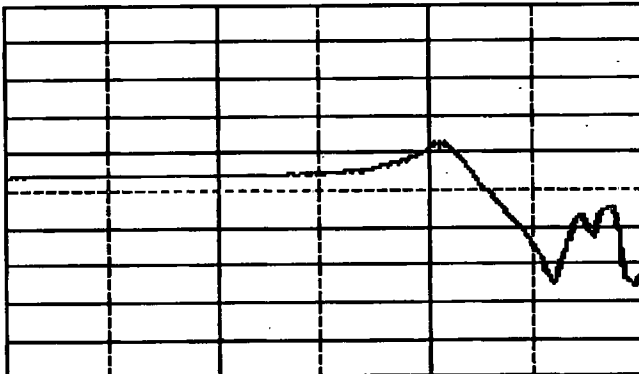

**LOG START: 1kHz**                      **LOG STOP: 1MHz**  
**OUT(B): 0.00dBm**                      **ST: AUTO x1**                      **1Me**  
**IRG: 20dBm**                      **RBW: 30kHz**                      **VBW: 30kHz**

Fig B30: Phase a / Tank to Phase A8 / Tank ( Phase / Tank Signalling mode , LV to HV).



MARK(210):337 200.00Hz  
A(\*):MAG 9.42dB 10dB/ -15.00dB

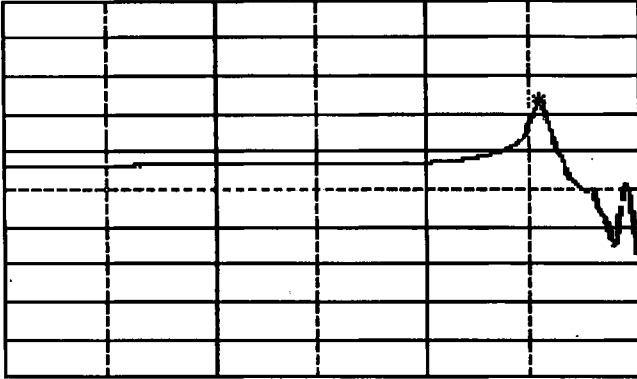

LOG START: 1kHz LOG STOP: 1MHz  
OUT(B): 0.00dBn ST: AUTO x1 1Hz  
IRG: 20dBn RBW: 30kHz VBW: 30kHz

Fig B30: Phases A8 / B8 to Phase a / Neutral  
( Phase / Neutral Signalling mode , HV to LV).

MARK(182):155 400.00Hz  
A(\*):MAG -3.00dB 10dB/ -15.00dB

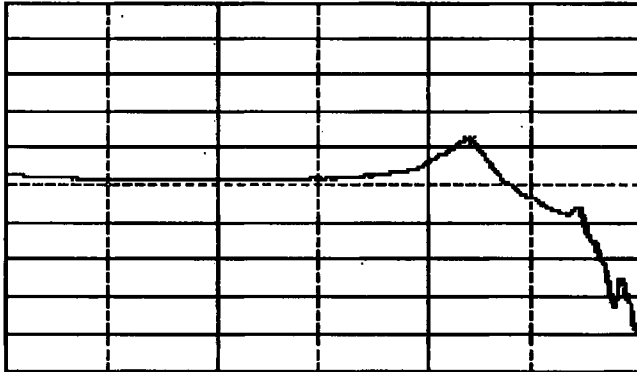

LOG START: 1kHz LOG STOP: 1MHz  
OUT(B): 0.00dBn ST: AUTO x1 1Hz  
IRG: 20dBn RBW: 30kHz VBW: 30kHz

Fig B31: Phase a / neutral to Phase A8 / B8  
( Phase / Neutral Signalling mode , LV to HV).

MFR<210>:337 200.00Hz  
R(\*):MAG 9.34dB 10dB/ -15.00dB

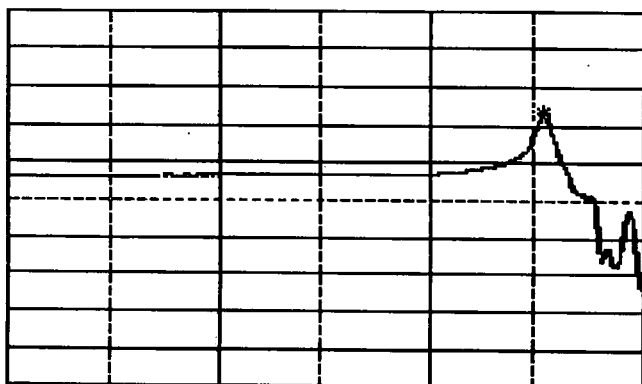

LOG START: 1kHz LOG STOP: 1MHz  
OUT(B): 0.00dBm ST: AUTO x1 1Me  
IRG: 20dBm RBW: 30kHz VBW: 30kHz

Fig B32: Phases A8 / B8 to Phases a / b ( Phase / Phase Signalling mode , HV to LV).

MFR<181>:151 200.00Hz  
R(\*):MAG -2.83dB 10dB/ -15.00dB

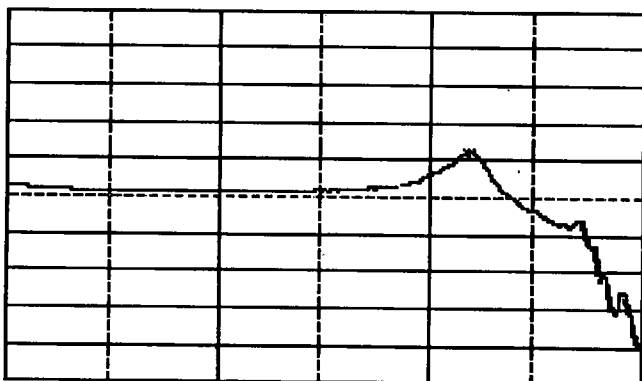

LOG START: 1kHz LOG STOP: 1MHz  
OUT(B): 0.00dBm ST: AUTO x1 1Me  
IRG: 20dBm RBW: 30kHz VBW: 30kHz

Fig B33: Phases a / b to Phases A8 / B8 ( Phase / Phase Signalling mode , LV to HV).

**1600KVA Transformer #2:**

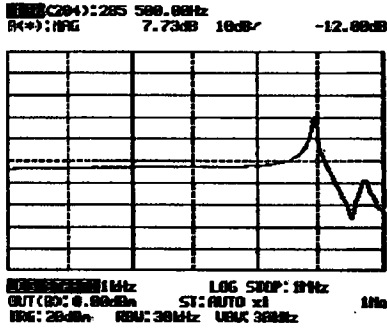

**Fig B34: Phase A8 / Tank to Phase a / Tank ( Phase / Tank signalling HV to LV ).**

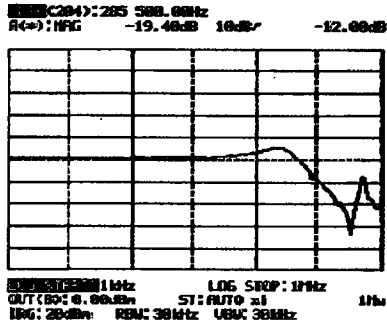

**Fig B35: Phase a / Tank to Phase A8 / Tank ( Phase / Tank signalling LV to HV ).**

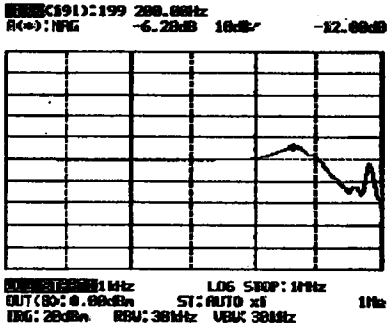

**Fig B36: Phase a / n to Phase A8 / B8 ( Phase / Neutral signalling LV to HV ).**

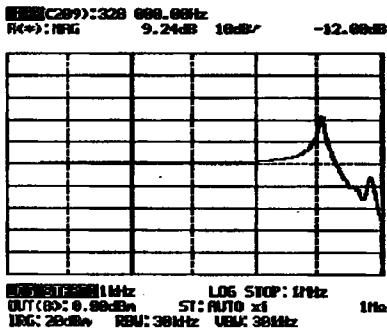

Fig B37: Phases A8 / B8 to Phase a / n ( Phase / Neutral signalling HV to LV ).

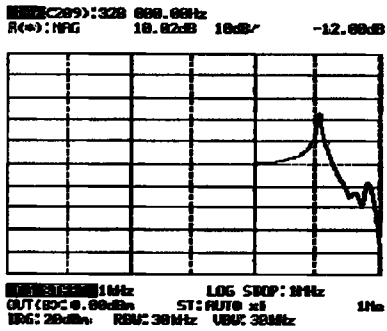

Fig B38: Phases A8 / B8 to Phase a / b ( Phase / Phase signalling HV to LV ).

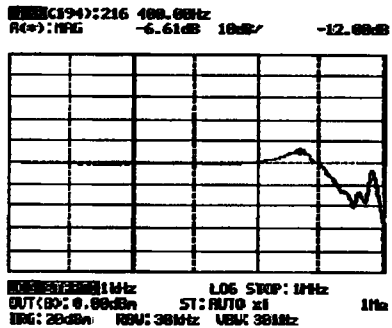

Fig B39: Phases a / b to Phases A8 / B8 ( Phase / Phase signalling LV to HV ).

## **Appendix C: Transformer Frequency Characteristics**

**( A 'Cross section' of energised plots )**

1000KVA Transformer:

REF(153): 12 816.88Hz  
 AC\*: MAG -33.84dB 10dB/ -40.00dB

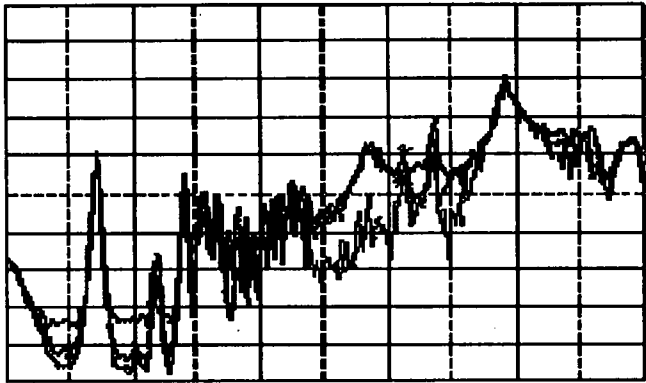

LOG START: 10Hz LOG STOP: 1MHz  
 OUT(B): 0.00dBm [H] AUTO x1 1No  
 SFG: 20dBm RBW: 30kHz USB: 30kHz

Fig C1: HV to LV Composite plot ( Phase / Tank signalling ) .

REF(155): 12 576.88Hz  
 AC\*: MAG 16.99dB 10dB/ -40.00dB

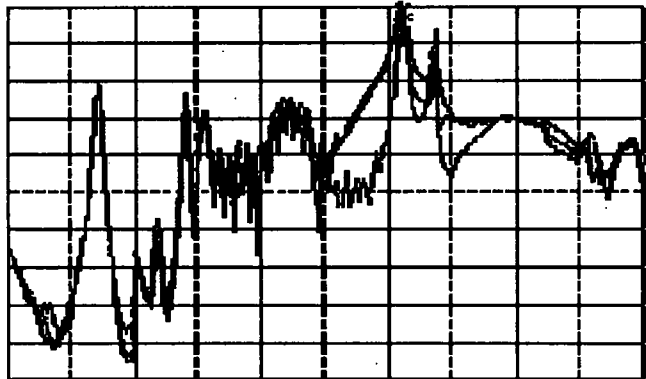

LOG START: 10Hz LOG STOP: 1MHz  
 OUT(B): 0.00dBm [H] AUTO x1 1No  
 SFG: 20dBm RBW: 30kHz USB: 30kHz

Fig C2: LV to HV Composite plot ( Phase / Tank signalling ) .

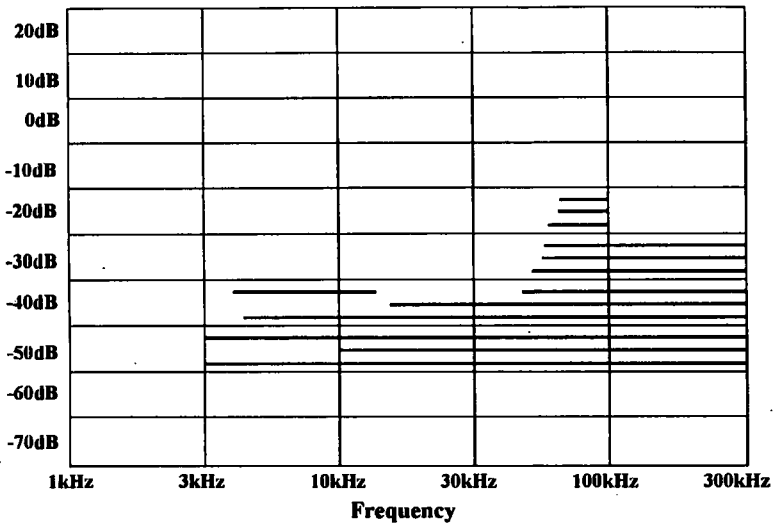

Fig C3: Transposed Composite Pass bands , HV to LV ( Phase / Tank signalling ) .

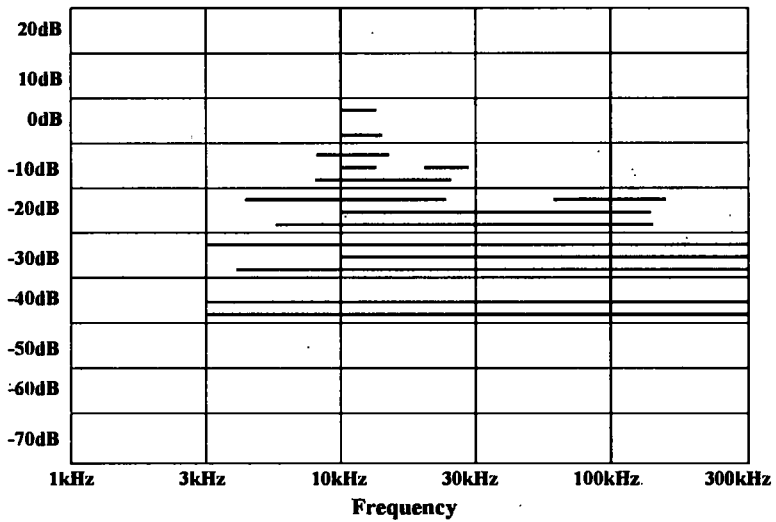
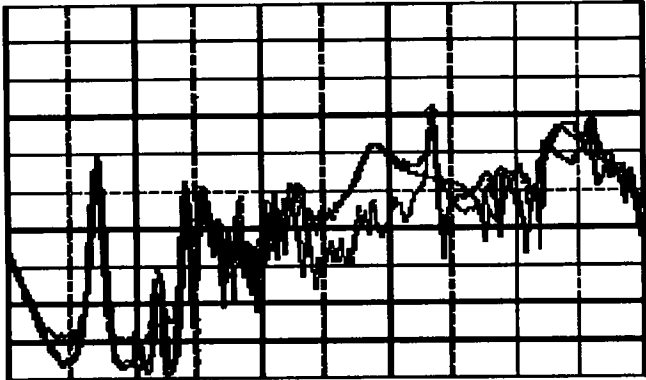

Fig C4: Transposed Composite Pass bands , LV to HV ( Phase / Tank signalling ) .

**REF(167):21 826.00Hz**  
**AC\*):MAG -19.21dB 10dB/ -40.00dB**



**LOG START:10Hz LOG STOP:1MHz**  
**OUT(B):0.00dBm  AUTO x1 1No**  
**IRG:20dBm RBW:30kHz USB:30kHz**

Fig C5: HV to LV Composite plot ( Phase / Neutral signalling ).

**REF(160):15 826.00Hz**  
**AC\*):MAG -19.13dB 10dB/ -40.00dB**

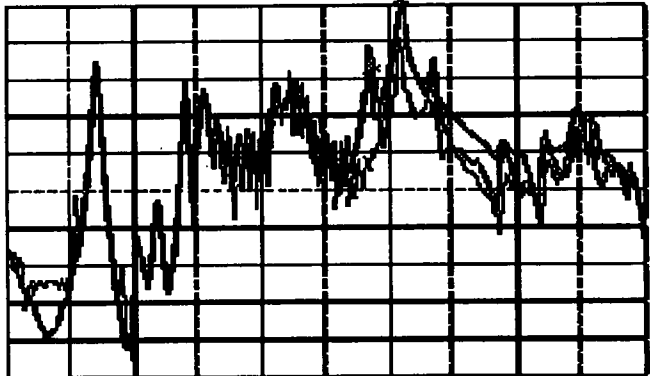

**LOG START:10Hz LOG STOP:1MHz**  
**OUT(B):0.00dBm  AUTO x1 1No**  
**IRG:20dBm RBW:30kHz USB:30kHz**

Fig C6: LV to HV Composite plot ( Phase / Neutral signalling ).



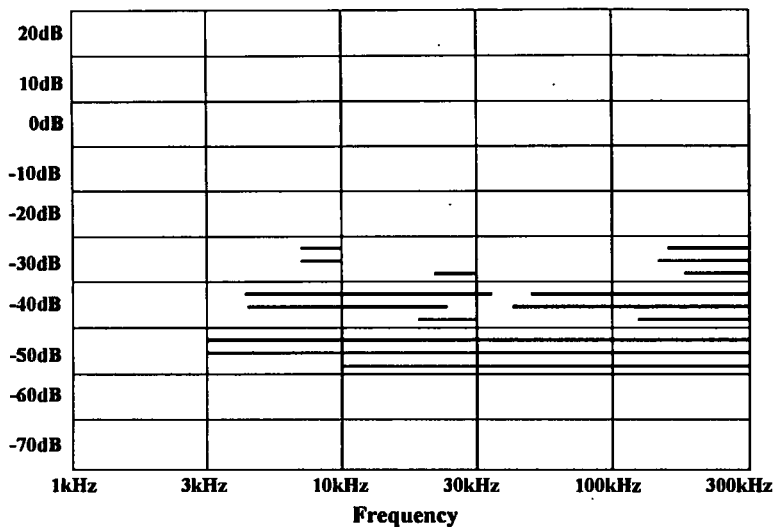

Fig C7: Transposed Composite Pass bands , HV to LV ( Phase / Neutral signalling ) .

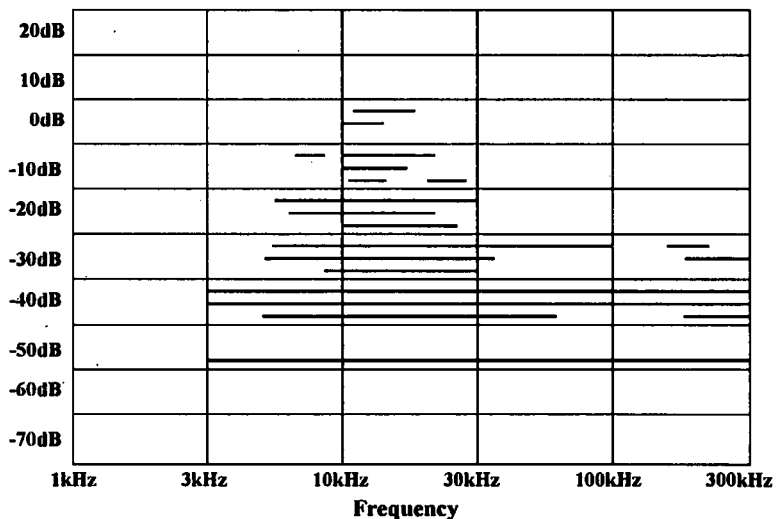
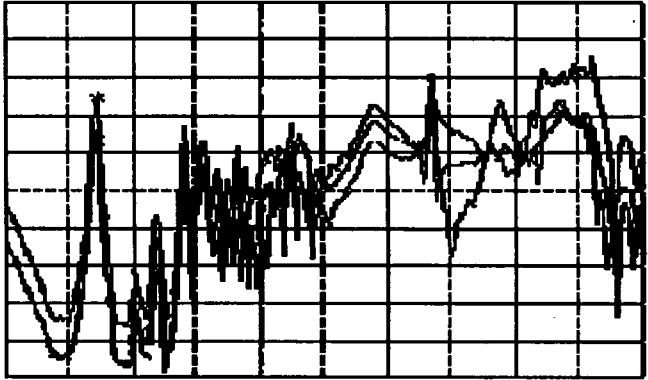

Fig C8: Transposed Composite Pass bands , LV to HV ( Phase / Neutral signalling ) .

MRK( 36):52.38Hz  
A(\*):MAG -26.40dB 10dB/ -48.88dB



LOG START: 10Hz LOG STOP: 1MHz  
OUT(B): 0.00dBm ST: AUTO x1 1Hz  
FRG: 20dBm RBW: 30kHz USB: 30kHz

Fig C9: HV to LV Composite plot ( Phase / Phase signalling ) .

MRK( 36):52.38Hz  
A(\*):MAG -6.54dB 10dB/ -48.88dB

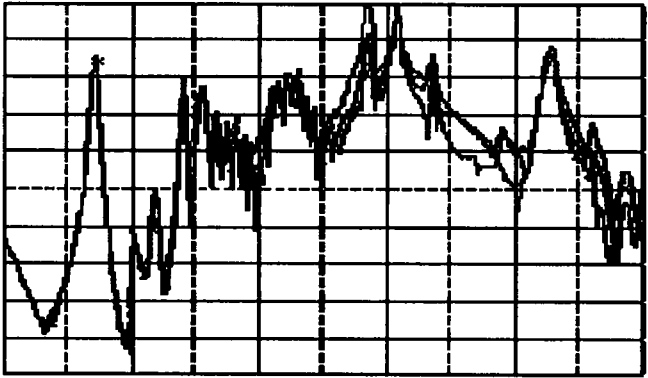

LOG START: 10Hz LOG STOP: 1MHz  
OUT(B): 0.00dBm ST: AUTO x1 1Hz  
FRG: 20dBm RBW: 30kHz USB: 30kHz

Fig C10: LV to HV Composite plot ( Phase / Phase signalling ) .

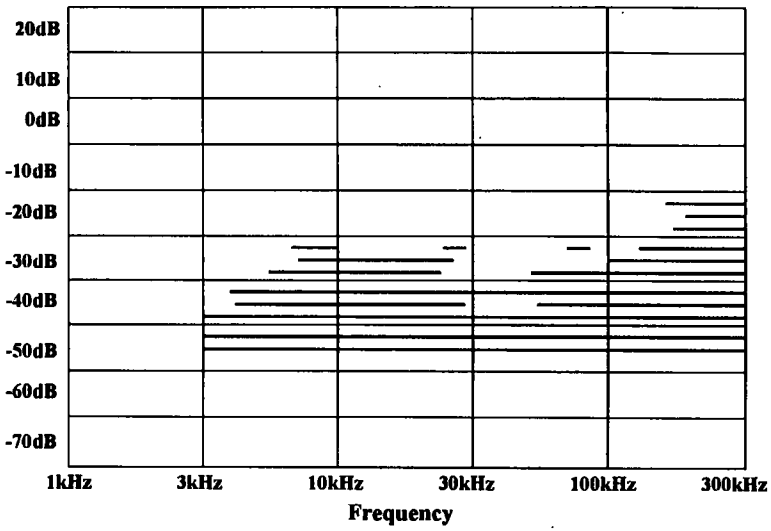

Fig C11: Transposed Composite Pass bands , HV to LV ( Phase / Phase signalling ) .

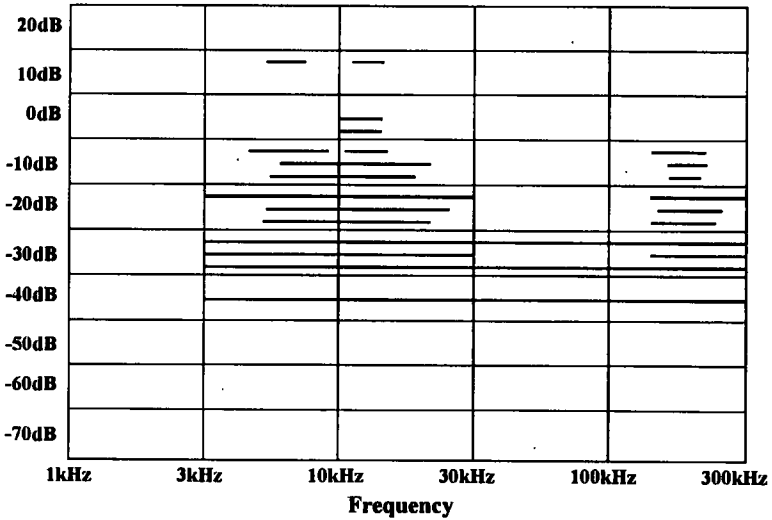
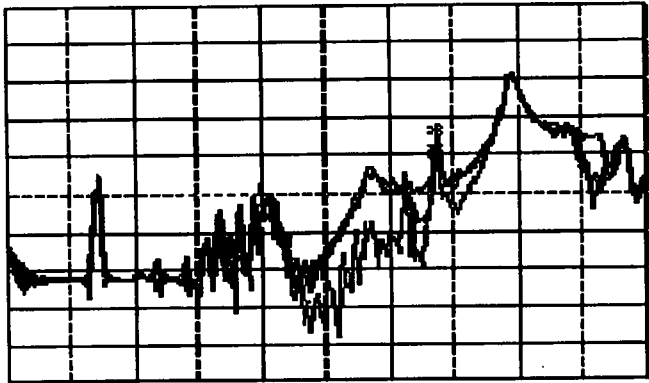

Fig C12: Transposed Composite Pass bands , LV to HV ( Phase / Phase signalling ) .

**400KVA Transformer:**

**REF(168):22 858.88Hz**  
**A(\*):MAG -28.71dB 10dB/ -40.50dB**



**LOG START:10Hz LOG STOP:1MHz**  
**OUT(B):0.00dBm  AUTO x1 1No**  
**IRG:20dBm RBW:30kHz USB:30kHz**

Fig C13: HV to LV Composite plot ( Phase / Tank signalling ).

**REF(168):22 858.88Hz**  
**A(\*):MAG -11.13dB 10dB/ -40.50dB**

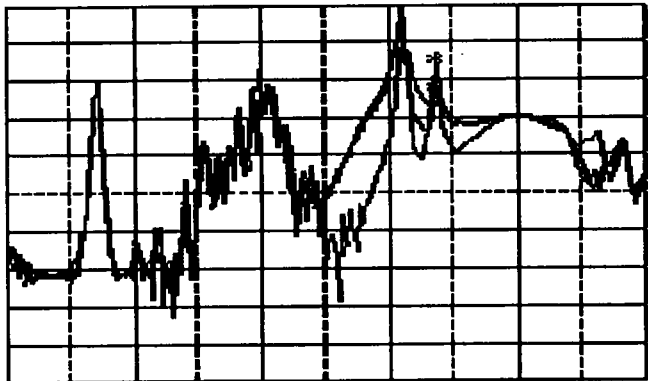

**LOG START:10Hz LOG STOP:1MHz**  
**OUT(B):0.00dBm  AUTO x1 1No**  
**IRG:20dBm RBW:30kHz USB:30kHz**

Fig C14: LV to HV Composite plot ( Phase / Tank signalling ).

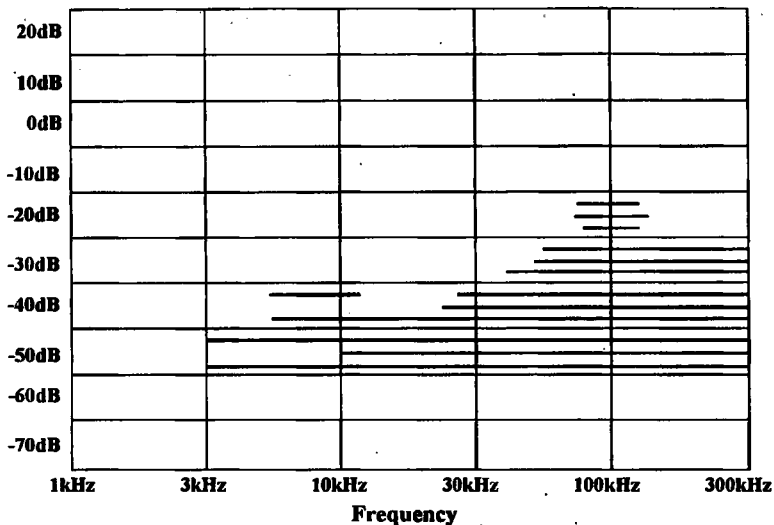

Fig C15: Transposed Composite Pass bands , HV to LV ( Phase / Tank signalling ) .

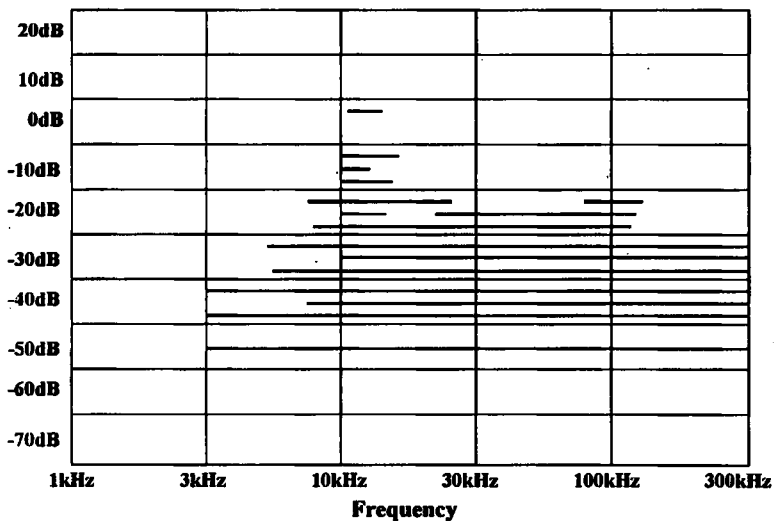
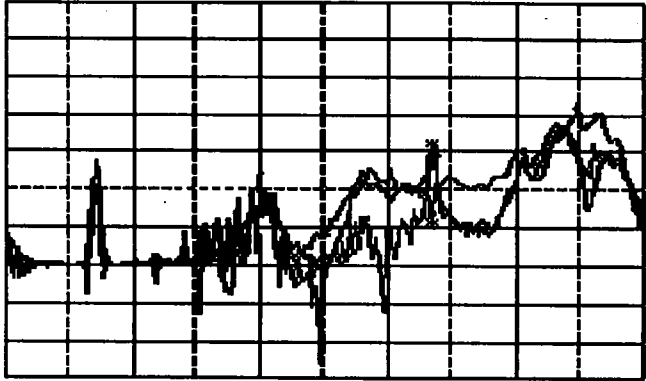

Fig C16: Transposed Composite Pass bands , LV to HV ( Phase / Tank signalling ) .

MEAS(167):21 826.08Hz  
A(\*):MAG -49.73dB 10dB/ -49.50dB



LOG START: 10Hz LOG STOP: 1MHz  
OUT(B): 0.00dBm EIAUTO x1 1Hz  
FREQ: 20dBm RBW: 30kHz USB: 30kHz

Fig C17: HV to LV Composite plot ( Phase / Neutral signalling ).

MEAS(167):21 826.08Hz  
A(\*):MAG -35.32dB 10dB/ -49.50dB

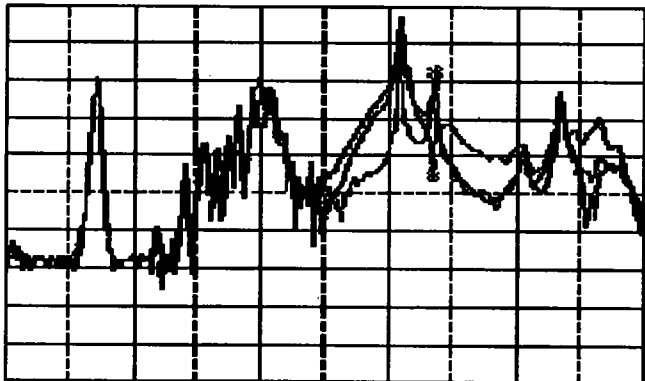

LOG START: 10Hz LOG STOP: 1MHz  
OUT(B): 0.00dBm EIAUTO x1 1Hz  
FREQ: 20dBm RBW: 30kHz USB: 30kHz

Fig C18: LV to HV Composite plot ( Phase / Neutral signalling ).

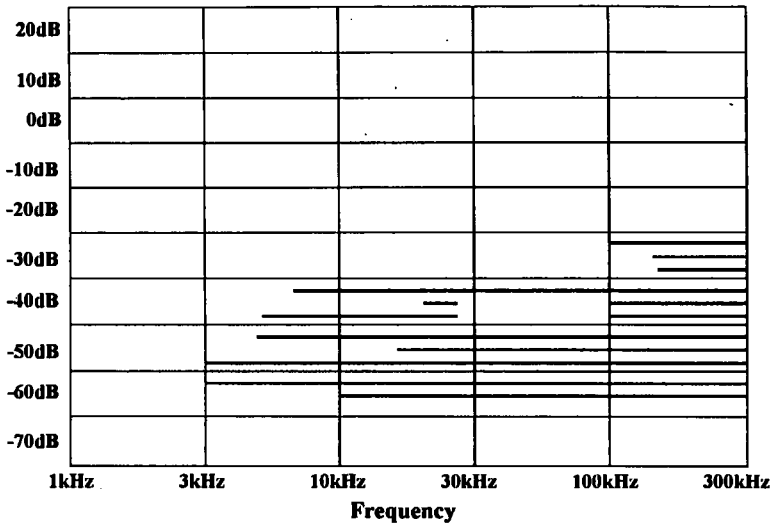

Fig C19: Transposed Composite Pass bands , HV to LV ( Phase / Neutral signalling ) .

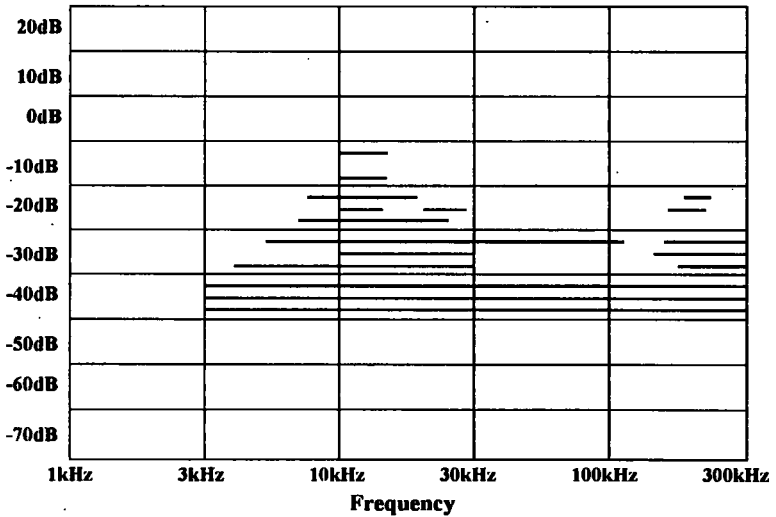
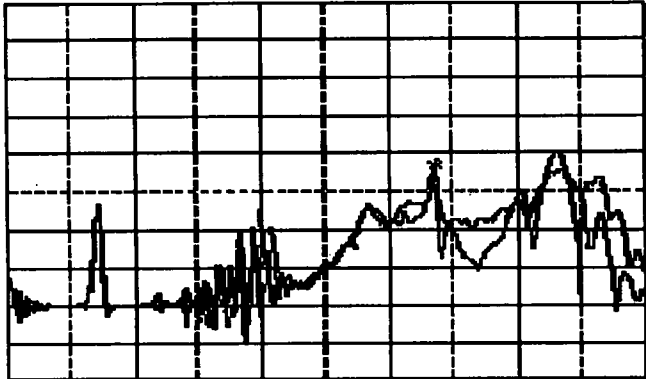

Fig C20: Transposed Composite Pass bands , LV to HV ( Phase / Neutral signalling ) .

REF(168):22 856.88Hz  
A(\*):MAG -23.17dB 10dB/ -30.50dB



LOG START: 10Hz LOG STOP: 1MHz  
OUT(B): 0.00dBm AUTO x1 1Hz  
1RG: 20dBm RBW: 30kHz USB: 30kHz

Fig C21: HV to LV Composite plot ( Phase / Phase signalling ) .

REF(168):22 856.88Hz  
A(\*):MAG -6.22dB 10dB/ -30.50dB

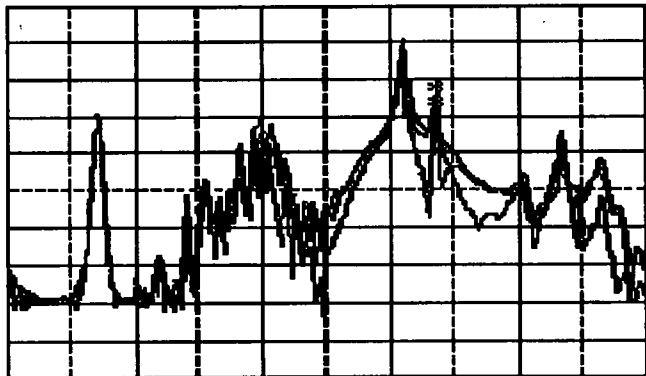

LOG START: 10Hz LOG STOP: 1MHz  
OUT(B): 0.00dBm AUTO x1 1Hz  
1RG: 20dBm RBW: 30kHz USB: 30kHz

Fig C22: LV to HV Composite plot ( Phase / Phase signalling ) .



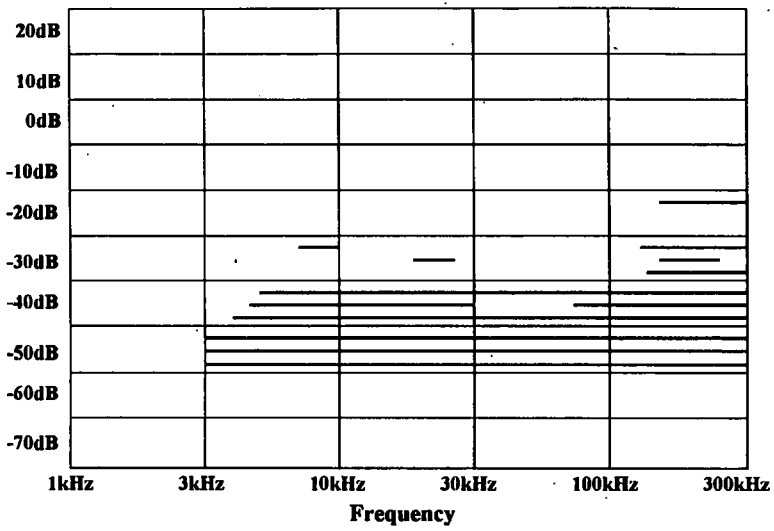

Fig C23: Transposed Composite Pass bands , HV to LV ( Phase / Phase signalling ) .

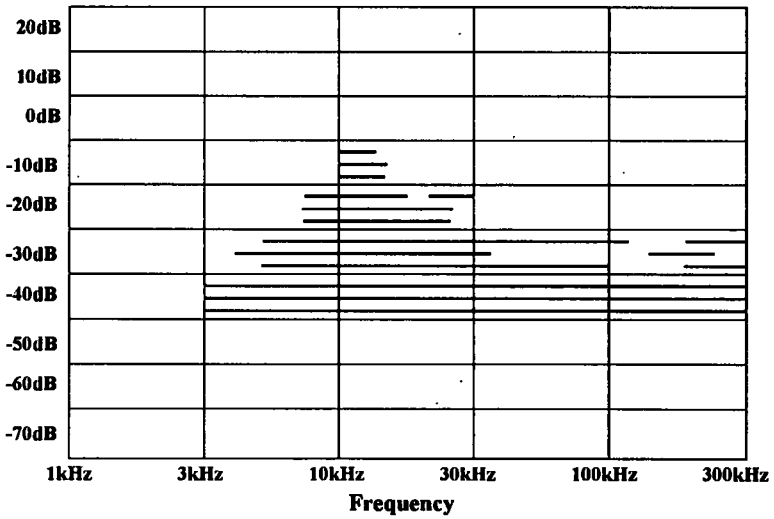
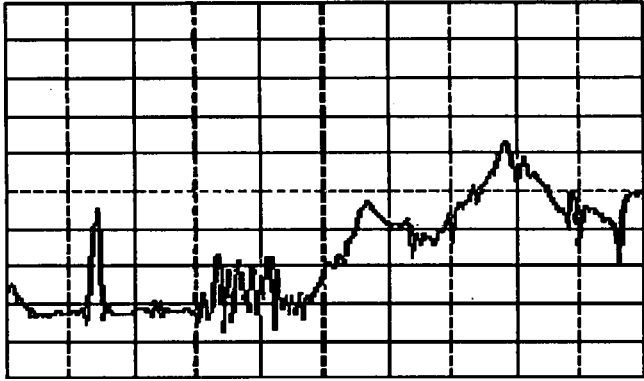

Fig C24: Transposed Composite Pass bands , LV to HV ( Phase / Phase signalling ) .

## 25KVA Single Phase Transformer:

REF(174):30 130.00Hz  
A(\*):MAG -39.67dB 10dB/ -30.90dB



LOG START: 10Hz LOG STOP: 1MHz  
OUT(B): 0.00dBm AUTO x1 1Hz  
IRG: 20dBm RBW: 30kHz USB: 30kHz

Fig C25: Phase A1 / Tank to Phase a1 / Tank ( phase / Tank signalling , HV to LV ) .

REF(174):30 130.00Hz  
A(\*):MAG -22.79dB 10dB/ -30.90dB

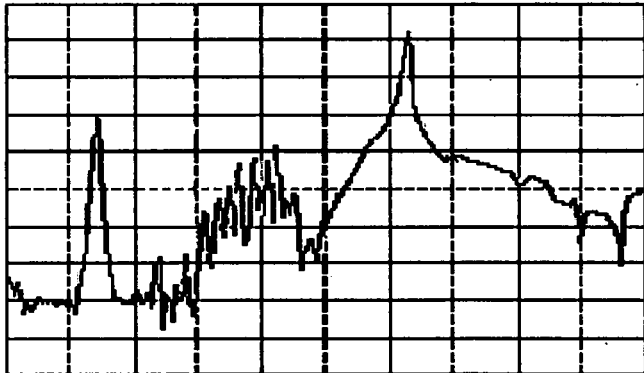

LOG START: 10Hz LOG STOP: 1MHz  
OUT(B): 0.00dBm AUTO x1 1Hz  
IRG: 20dBm RBW: 30kHz USB: 30kHz

Fig C26: Phase a1 / Tank to Phase A1 / Tank ( phase / Tank signalling , LV to HV ) .

**174**(174):30 130.00Hz  
**A(\*)**:MAG -35.44dB 10dB/ -30.90dB

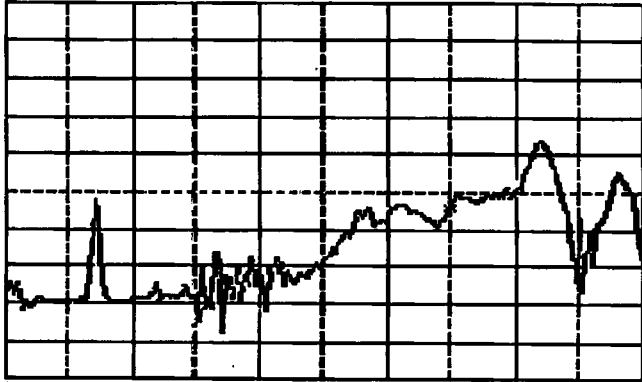

LOG START:10Hz LOG STOP:1MHz  
 OUT(B):0.00dBm **AUTO** x1 1Hz  
 IRG:20dBm RBW:30kHz USB:30kHz

Fig C27: Phases A1 / A2 to Phases a1 / a2 ( Phase / 'neutral' signalling , HV to LV ).

**174**(174):30 130.00Hz  
**A(\*)**:MAG -26.59dB 10dB/ -30.90dB

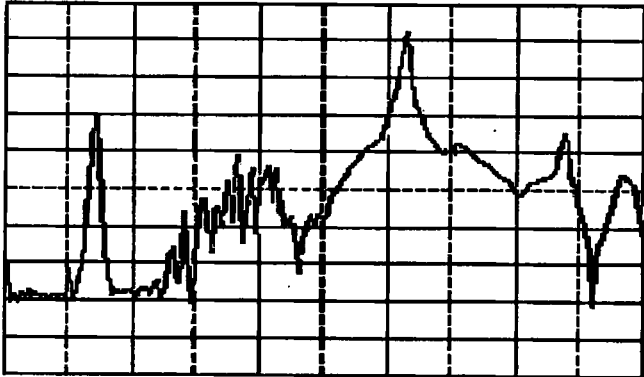

LOG START:10Hz LOG STOP:1MHz  
 OUT(B):0.00dBm **AUTO** x1 1Hz  
 IRG:20dBm RBW:30kHz USB:30kHz

Fig C28: Phases a4/a2 / a3/a1 to Phases A1/A2  
 ( Parallel , phase 'neutral' mode , LV to HV ).

1600KVA Transformer #2:

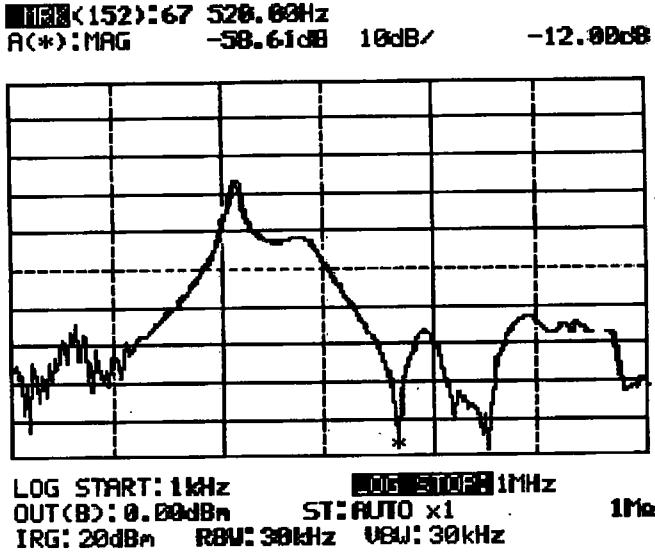

Fig C29: Phase a / Tank to Phase A8 / Tank ( Phase / Tank mode signalling , LV to HV ).

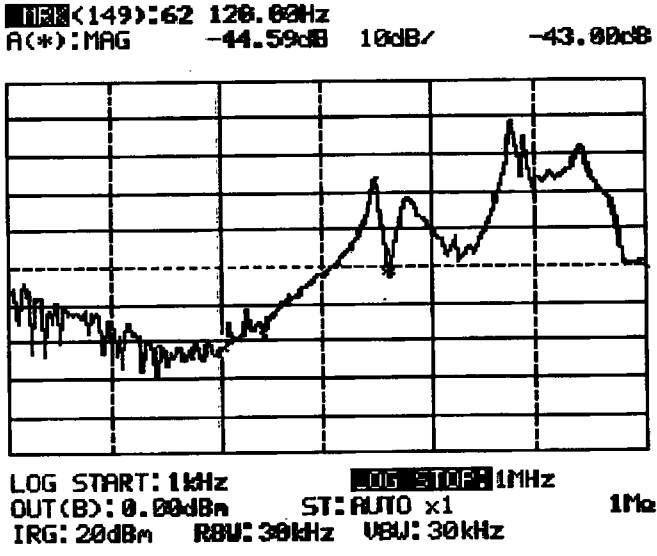

Fig C30: Phase A8 / Tank to Phase a / Tank ( Phase / Tank mode signalling , HV to LV ).

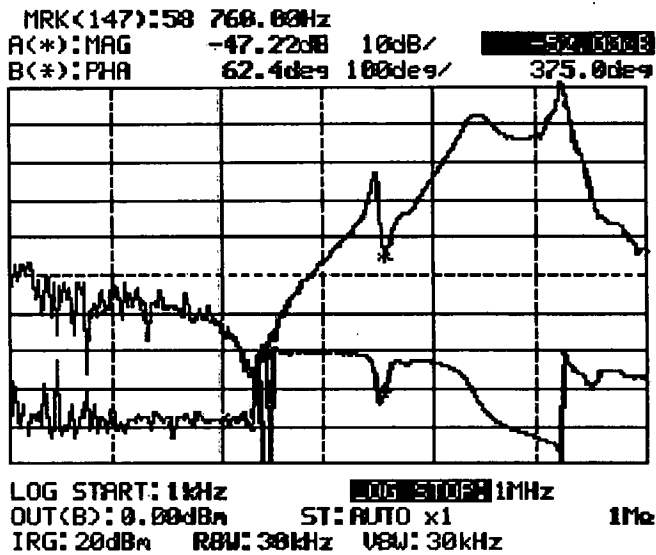

Fig C31: Phase A8 / Neutral to Phase a / Neutral  
 (Phase / Neutral mode signalling , HV to LV).

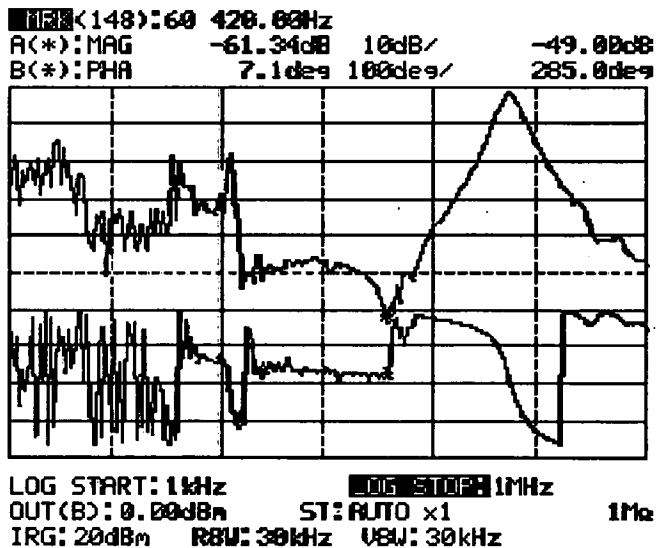

Fig C32: Phase a / Neutral to Phase A8 / Neutral  
 (Phase / Neutral mode signalling , LV to HV).

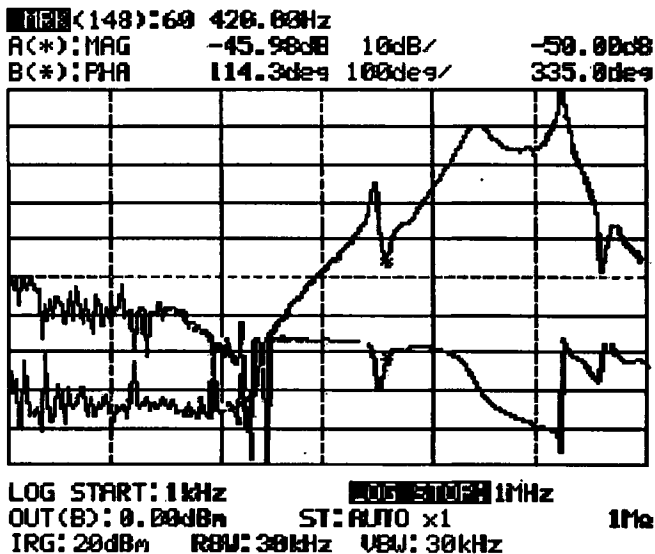

Fig C33: Phases A8 / B8 to Phases a / b  
 ( Phase / Phase mode signalling , HV to LV ).

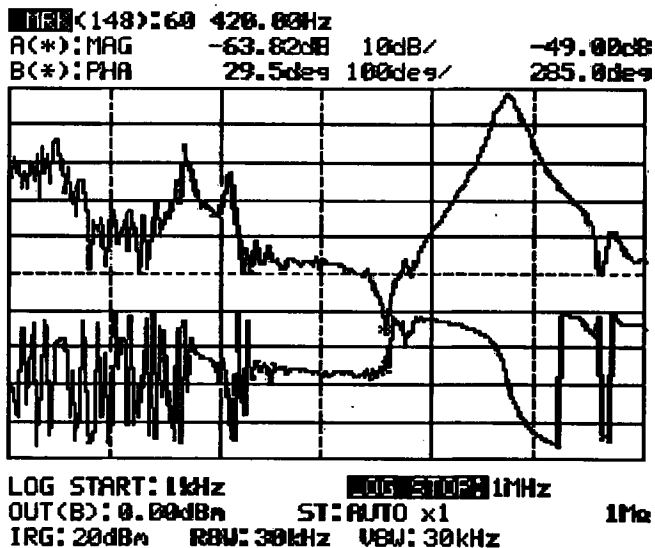

Fig C34: Phase a / b to Phase A8 / B8  
 ( Phase / Phase mode signalling , LV to HV ).