



THE UNIVERSITY *of* EDINBURGH

Edinburgh Research Explorer

Powering the Internet of Things Through Light Communication

Citation for published version:

Demirkol, I, Camps-Mur, D, Paradells, J, Combalia, M, Popoola, W & Haas, H 2019, 'Powering the Internet of Things Through Light Communication', *IEEE Communications Magazine*.
<https://doi.org/10.1109/MCOM.2019.1800429>

Digital Object Identifier (DOI):

[10.1109/MCOM.2019.1800429](https://doi.org/10.1109/MCOM.2019.1800429)

Link:

[Link to publication record in Edinburgh Research Explorer](#)

Document Version:

Peer reviewed version

Published In:

IEEE Communications Magazine

General rights

Copyright for the publications made accessible via the Edinburgh Research Explorer is retained by the author(s) and / or other copyright owners and it is a condition of accessing these publications that users recognise and abide by the legal requirements associated with these rights.

Take down policy

The University of Edinburgh has made every reasonable effort to ensure that Edinburgh Research Explorer content complies with UK legislation. If you believe that the public display of this file breaches copyright please contact openaccess@ed.ac.uk providing details, and we will remove access to the work immediately and investigate your claim.



Powering the Internet of Things Through Light Communication

Ilker Demirkol, Daniel Camps-Mur, J. Paradells, M. Combalia, W. Popoola, and H. Haas

The authors present LiFi4IoT, a system which, in addition to communication, provides three main services that the Radio Frequency (RF) IoT networks struggle to offer: precise device positioning; the possibility of delivering power, since energy can be harvested from light; and an inherent security due to the propagation properties of visible light.

ABSTRACT

Novel solutions are required to connect billions of devices to the network as envisioned by the IoT. In this article we propose to use LiFi, which is based on off-the-shelf LEDs, as an enabler for the IoT in indoor environments. We present LiFi4IoT, a system which, in addition to communication, provides three main services that the radio frequency (RF) IoT networks struggle to offer: precise device positioning; the possibility of delivering power, since energy can be harvested from light; and inherent security due to the propagation properties of visible light. We analyze the application space of IoT in indoor scenarios, and propose a LiFi4IoT access point (AP) that communicates simultaneously with IoT devices featuring different types of detectors, such as CMOS camera sensors, PDs, and solar cells. Based on the capabilities of these technologies, we define three types of energy self-sufficient IoT “motes” and analyze their feasibility. Finally, we identify the main research directions to enable the LiFi4IoT vision and provide preliminary results for several of these.

INTRODUCTION

Embedding intelligence to everyday objects and providing Internet connectivity to these objects, also known as the Internet of Things (IoT) paradigm, is becoming a reality. However, along with the benefits it promises, this paradigm also presents significant challenges, especially related to communications. Pervasive IoT will require a very large number of connections per unit area, high aggregate bandwidth, ubiquitous coverage, sustainable energy resources, and a high level of security. A promising IoT communication solution that can address these challenges is Light Fidelity (LiFi), which consists of networked light communications using the visible and the infrared spectrum. In particular, a key advantage of leveraging the visible spectrum for IoT communications is the fact that a lighting infrastructure composed of LED luminaires is being adopted extensively [1] and will provide illumination to indoor spaces where IoT communication is most needed. Densely deployed illumination points can be converted into IoT access points (APs) addressing the challenge of high density IoT nodes, enabling short range communication to achieve low energy consumption for power-constrained nodes.

Moreover, as light is ubiquitous, it is an ideal source for energy harvesting compared to other sources such as temperature difference, movement, or radio frequency (RF), and its higher-efficiency energy harvester technology (i.e., solar cells) results in compact and lower-cost solutions [2].

LiFi offers several advantages over RF for indoor IoT communication. Apart from the energy-autonomous operation it enables at the receiver side [3], LiFi provides inherent security, since its signals do not penetrate walls. Such a secrecy feature is an important requirement for IoT applications such as the ones for Industry 4.0. LiFi is also better suited to enable high-precision indoor localization [4], which is critical for IoT applications such as asset tracking. Although LiFi functions where light illumination is mostly available, such as warehouses, offices, hospitals, and so on, studies show that several Mb/s data rate is possible when the lights are off (i.e., perceived as off) [5]. Moreover, the already crowded RF spectrum is not expected to serve the projected several billions of IoT devices, for which LiFi spectrum will be a critical solution.

The use of LiFi for IoT has been a recent research topic, with most of the early studies focusing on the energy-harvesting aspect of LiFi for IoT nodes or the hybrid operation of LiFi with RF, for example, [3, 66]. This article presents a comprehensive analysis of LiFi for IoT communication, describing how LiFi is suited to satisfy the diverse IoT requirements. In fact, the wide IoT application space exhibits diverse traffic characteristics as listed in Table 1. As seen in the table, the requirements from the IoT communication network vary based on the application category. We advocate that the LiFi4IoT system described in this article can address all these requirements. The details of the LiFi4IoT system, which is composed of an AP and energy self-sufficient LiFi4IoT motes, are provided below. We present a general architecture design for LiFi4IoT, and provide the design and feasibility analysis of three types of LiFi4IoT motes that cover the application space for indoor IoT provided in Table 1. We then list the research challenges that need to be solved to enable the vision of LiFi4IoT, and provide preliminary results for solutions targeting several of these challenges. Finally, we conclude the article.

LiFi4IoT SYSTEM VISION

LiFi4IoT COMMUNICATION TECHNOLOGIES AND SYSTEM ARCHITECTURE

Although there is an extensive research effort toward high speed LiFi communication, the potential LiFi communication technologies that can address the low-rate IoT requirements listed in Table 1 are limited. Several key technology candidates to be employed in LiFi4IoT devices, and the IoT application space they can address, are analyzed in Table 2. Combinations of these technologies can be used to define LiFi4IoT device transceivers, or motes, for different applications. For example, an energy-autonomous mote solution would call for a solar panel as the downlink receptor for energy harvesting purposes. Consequently, and based on the application space analysis of Table 1, we define four types of motes shown in the conceptual architecture of the LiFi4IoT system in Fig. 1. The mote technologies and the corresponding designs are detailed below.

The vision of LiFi4IoT is to realize an integrated AP solution that is able to communicate with LiFi4IoT devices with different communication technologies. Figure 1 proposes such an AP solution, composed of a modulator, controlling the light intensity of an off-the-shelf LED through a driver, and optional receiver modules depending on the considered uplink technologies. By varying the light intensity, the AP performs downlink communication toward the LiFi4IoT devices. In addition, a LiFi controller coordinates communication between APs. The LiFi controller may interface with the IP network and with the radio access networks (RAN), the latter being necessary for hybrid motes that combine the RF and LiFi technologies.

Receiver technologies supporting the low power requirements of LiFi4IoT devices are needed at the AP. A CMOS camera is a receiver option that allows simultaneous low bit rate transfers (limited by the camera frame rate) from multiple devices, while enabling spatial multiplexing. This is an attractive solution to enable real-time tracking of numerous low power LiFi tags.

IoT application type	UL bit rate	DL bit rate	UL Dt	DL Dt
1) Event driven monitoring: report the event and periodic keep alive messages. Example: report presence.	b/s-Mb/s ¹	b/s-kb/s ²	L	N/A
2) Continuous (periodical) low data-rate monitoring. Example: Temperature data.	bp/s-kb/s ¹	b/s-kb/s ³	M	L
3) Actuator: remote control of actuators. Example: door opening.	b/s-kb/s ²	kb/s-Mb/s	L	L
4) Rich monitoring: Sensors generating high data volume. Example: accelerometer.	kb/s-Mb/s ¹	bps-kb/s ³	L	L
5) Asset/object tracking: periodic ID transmission. Example: warehouse tracking.	bps-kb/s	bps-kb/s ³	L/M	–
6) Location-based end-user services. Example: localization in shopping malls.	–	b/s-kb/s	–	VL

¹ Measurement details data, ² for ACK, ³ if ACK or paging is used; Dt: latency; L: low; M: medium; VL: very Low (to achieve tens of location estimates per second).

Table 1. IoT Application space and the corresponding traffic requirements.

Another option is to use high sensitivity detectors as PDs, such as a single photon avalanche diode (SPAD), or arrays thereof [7]. A SPAD device is capable of higher bit rates (tens of Mb/s) and can be used to receive data from all devices in the AP coverage area.

To enable high-precision (i.e., cm level) indoor position information of a LiFi4IoT device, a CMOS camera is needed, either at the AP or at the device [4]. The former allows a lower cost system and requires less power. In the case of a high bit rate uplink requirement in addition to the location service, the latter alternative can be considered. However, this would limit the achievable downlink bit rate and increase the power consumption, albeit offering an easy implementation for existing smartphones.

LiFi4IoT MOTE TYPES AND FEASIBILITY ANALYSIS

Based on the application requirements of Table 1 and the available technologies of Table 2, we

Direction	Technology	Bit rate	Cost	Power consumption	Deployment complexity	Additional functionality	Matching app. type (Table 1)
Downlink (reception)	Photo diode	Few Mb/s	L	L	L		1, 3, 4
	Solar panel	Tens of kb/s (for COTS panels)	M	–	M ¹	Can harvest energy	2, 5
	OCC	Few kb/s	H	H	M ¹	Can provide precise location	6
Uplink (transmission)	(Infrared) LED	Tens of Mb/s	L	M	M ²	Can support CMOS or SPAD receiver at the AP	3, 4
	Retroreflector	Hundreds of b/s	M	L	M ²	Requires the usage of CMOS receiver at the AP	2, 5
	Radio frequency	Hundreds of kb/s, tens of Mb/s	M	H	L ³		1, 4

¹ LOS recommended ²; LOS needed ³; LOS not required; OCC: optical camera communication; L: low; M: medium; H: high.

Table 2. Features of downlink and uplink technology candidates for LiFi4IoT devices (motes).

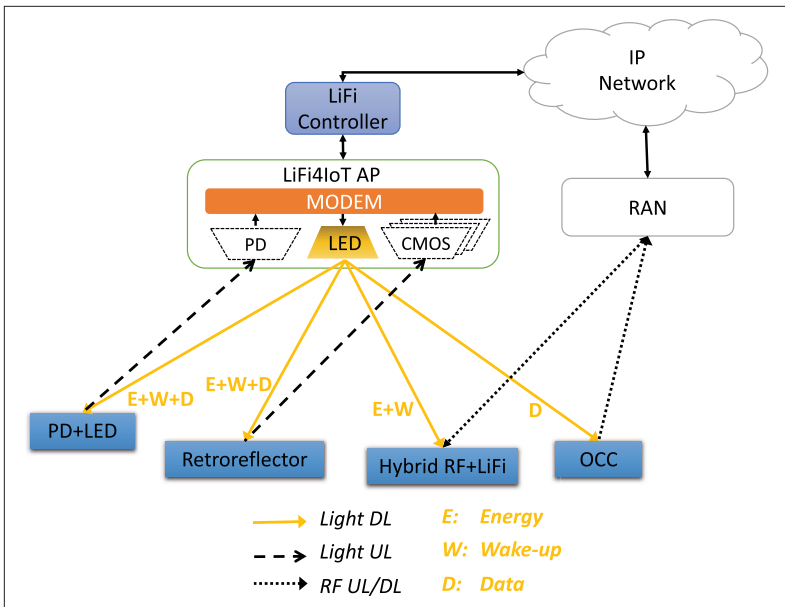

Figure 1. LiFi4IoT system architecture and its working principle.

derive four types of IoT devices a LiFi4IoT AP should be able to communicate to. These devices include three energy self-sufficient motes (Fig. 2), which cover the most promising low-complexity, low-power and low form-factor solutions suited for the IoT. The fourth device is an optical camera communication (OCC) device that is already available today, for example through smartphones [4]. In the following, we detail prospective mote designs, along with their feasibility analysis in terms of energy and bit-rate performances.

LiFi4IoT Retroreflector Mote: A liquid crystal shutter on top of a retroreflector at the mote enables the use of light backscattering as an uplink technology. Since the liquid crystal shutters are very low-cost and consume low-power, this technology is expected to be employed for many use cases in the future. For such mote technology, a CMOS image sensor is employed at the AP side. This will allow for simultaneous uplink communication with numerous motes, in addition to the added functionality of localization of the motes through the image sensor (reflected light excited) pixel location.

Feasibility Analysis: Modern low-power micro-controller units (MCUs) come with options to reduce the MCU frequency or to reduce the clock speeds. Since the maximum modulation frequency of the state-of-the-art LCD shutters vary between 100 Hz and 1000 Hz, the use of low-power run mode of, for example, STM32L1 MCU working at 32 kHz clock would be enough for the operation of the LiFi4IoT Retroreflector mote. In low-power run mode with the LCD driver enabled, the consumption of the CPU is 23.9 W. State-of-the-art LCD shutters [8] consume less than 0.2 μ W at 200 Hz. Hence, the Retroreflector mote is expected to consume \sim 24 μ W in its active mode, with a bit rate of 200 bps using On-Off Keying (OOK). This complies with the results of [8], achieved with a range of 5 meters and using a retroreflector of a 20 mm radius. The harvested power is given as $P = I \times A \times \text{Eff}_{\text{solar}}$, where I denotes the illumination intensity in units of mW/cm², A represents the solar cell area, and $\text{Eff}_{\text{solar}}$

represents the solar cell efficiency factor. According to a recent indoor solar cell technology characterization, $\text{Eff}_{\text{solar}} = 15$ percent for $I = 0.1$ mW/cm², and $\text{Eff}_{\text{solar}} = 20$ percent for $I = 10$ mW/cm² [9]. Then, for the lower illumination intensity of 0.1 mW/cm², the solar cell area should be at least $A > P/I/\text{Eff}_{\text{solar}} = 1.6$ cm². As a result, a target size greater than 1.6 cm² would provide enough energy from indoor light harvesting for an energy-autonomous functioning.

With the standard 30 fps frame rate image sensors, the achievable per mote data rate is limited to 15 bps (sampling at Nyquist frequency) for an OOK uplink modulation. Given the aforementioned energy budget calculation, these motes can always be on, working at a constant data rate, and represent a good candidate to address application types 2 and 5 in Table 1.

LiFi4IoT PD+LED Mote: This mote solution defines two operational states. In the sleep state, the solar cell harvests energy from the ambient light, which can be stored to power the IoT mote when in active mode. To wake up the IoT mote, a “wake-up” optical signal is broadcast from the AP. A solar cell is used to double as the “wake-up” signal receiver through an addressable, ultra-low-power wake-up circuitry [3] that decodes the wake-up signal and turns on the IoT mote with the correct address. In the active state, the IoT mote communicates with the AP using the LEDs (possibly infrared) for uplink data transfer, and a high sensitivity photodiode is used both as downlink and uplink receivers.

Feasibility Analysis: A total harvestable power in the order of 2 mW/cm² is feasible from typical indoor lighting [9]. For a mote with a moderate 10 cm² solar panel, which is reasonable in industrial scenarios, the total harvestable power is 20 mW. By sharing the harvested power equally among sensing, processing and communication functions, a peak electrical power of about 6.6 mW is available for each function. If an uplink transmitter is a typical LED, for example, the L909 LED from Hamamatsu, which radiates 10 mW optical power when operated continuously at a drive current of 50 mA and forward voltage of 1.4 V, then the LED power consumption is 70mW. As the mote is not expected to be active at all times, the dissipated electrical power will be less than this value. With a duty cycle of 1/100, the electrical power consumed by the LED transmitter will be 0.7 mW. Considering an optical receiver with 13 mm² sensitive area (e.g., S1223-01 from Hamamatsu) located 3 m away, due to direct line-of-sight (LOS) path loss, the amount of optical power reaching this receiver from the IoT node is estimated to be \sim 4.6 nW. The minimum detectable power from an optical receiver is given as the $\text{NEP} \times \sqrt{\text{BW}}$, where NEP is the noise equivalent power with a typical value of 10^{-14} W/Hz^{1/2} and BW is the bandwidth. For a modest 10 MHz receiver bandwidth, the minimum detectable power (sensitivity) at the receiver is about 32 pW, two orders of magnitude lower than the estimated received power. Hence, such an LED can be used to establish a reliable communication link.

For the receiver, the power dissipated by the photodiode will depend on the reverse bias voltage across it. For a representative bias voltage of 1.2 V, a typical value for the bias current is about

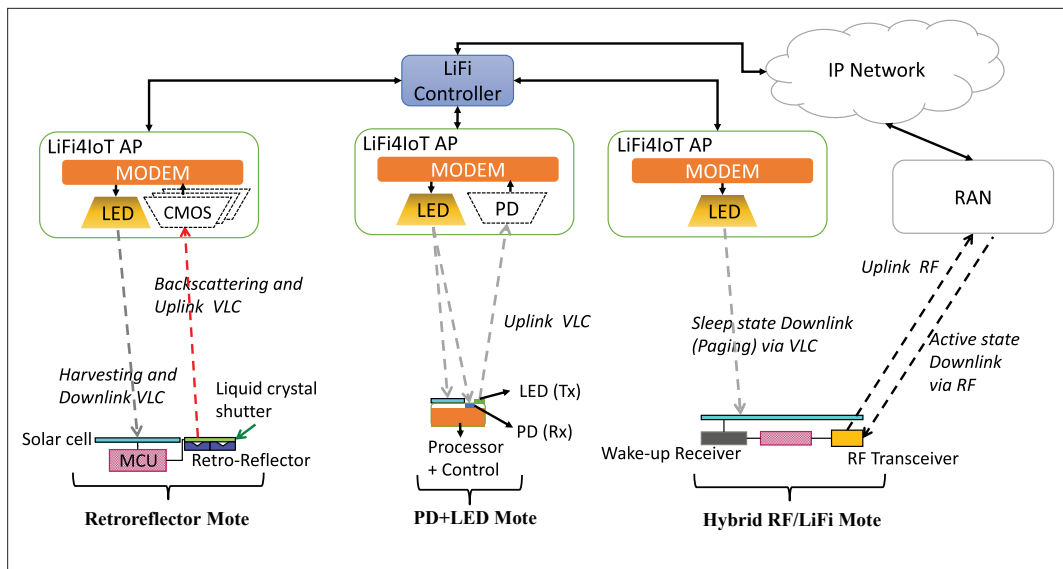

Figure 2. Schematic LiFi4IoT System: LiFi4IoT AP and motes.

1 μA ; resulting in electrical power consumption of 1.2 μW . Thus, the total estimated power dissipated during data transfer is far less than the amount allocated for that function. For a low power microcontroller, such as STM32L1, which requires about 200 μA and a minimum of 1.2 V, that is, a minimum of 240 μW is required for a 4 MHz clock rate. With this setup, we foresee scalable data rates of a few kb/s to 2 Mb/s over a typical indoor separation distance of up to 3 m. With a duty-cycle of 1/10, the average power consumption is 24 μW , the feasibility of which is justified in the previous analysis. Hence, such duty-cycled high-speed operation is a good candidate to support application types 1, 3 and 4 in Table 1.

LiFi4IoT Hybrid RF/LiFi Mote: A hybrid RF-LiFi mote, where the LiFi downlink will be used for paging, enables the use of RF communication in an energy-efficient way. During the sleep state, a wake-up receiver circuit is used to decode the paging messages passed through the solar cell. These messages include the address (or class) of the target device, the successful matching of which triggers a wake-up interrupt of the MCU, which in turn starts the uplink RF communication.

Feasibility Analysis: The wake-up receiver targeted requires 8 μA in the correlation phase (after receiving a carrier burst) and 2.4 μA in the listening phase [3]. With an operational voltage of 2.4 V, the required power is then 19.2 μW assuming the worst case of correlation phase. Then, for the lower illumination intensity of 0.1 mW/cm^2 , the solar cell area should be at least $A > P/I/\text{Eff}_{\text{solar}} = 0.019/0.1/0.15 = 1.28 \text{ cm}^2$. Note that these power budget calculations assume always correlation mode. However, the mote will mostly be in the listening phase waiting for a carrier burst. Based on the RF chip energy consumption and the frequency of the RF communication, one can determine the required duty cycle for the uplink communication. The additional energy scavenged with the solar panel can be stored in a capacitor or battery, which can be used toward the RF communication for an energy-autonomous operation. This type of mote is suitable for different application types, including types 1 and 4 in Table 1.

LiFi4IoT OCC Device: This device employs OCC that allows data reception from multiple transmitters along with their relative locations (through pixel calculations). Given the CMOS camera sensors power consumption, the OCC device is not expected to operate solely on harvested energy. Thus, hybrid designs combining solar cells and batteries can be considered. A primary target of the OCC device is to enable high precision, that is, cm-level, 3D positioning using the LiFi4IoT APs as references, and low data rate location-based services. In this article, we focus on the smartphones as OCC devices, for which such indoor precision is important. Since it is assumed that this device will require a battery to operate, we omit its feasibility analysis. This type of device is well suited for application type 6 in Table 1.

LIIFI4IOT RESEARCH DIRECTIONS

In this section, we present the key research directions that will enable the LiFi4IoT vision. We also assess the ongoing studies in these research lines and present respective preliminary results, where possible.

MITIGATING THE LIMITATIONS OF LIIFI IN COMPARISON TO RF

Compared to RF, there are several limitations and challenges brought by LiFi. An important challenge is that LiFi signals are significantly attenuated when the LOS link is blocked. This will lead to a large drop in the link data rate, and in the worst case this could lead to outage. Therefore, its system design requires powerful link adaptation techniques, and a sufficient degree of diversity. As a result, concepts such as joint transmission and coordinated multipoint (CoMP) are required.

Another challenge stems from the fact that LiFi uses intensity modulation/direct detection (IM/DD). As a result, information cannot be encoded in the phase of the light signal. Consequently, tailored techniques are required to ensure high spectrum efficiency while the energy efficiency is not compromised either.

LEDs are natural beamformers, due to their narrow field of view (FoV) property. This has

Compared to RF, there are several limitations and challenges brought by LiFi. An important challenge is that LiFi signals are significantly attenuated when the LOS link is blocked. This will lead to a large drop in the link data rate, and in the worst case this could lead to outage. Therefore, its system design requires powerful link adaptation techniques, and a sufficient degree of diversity.

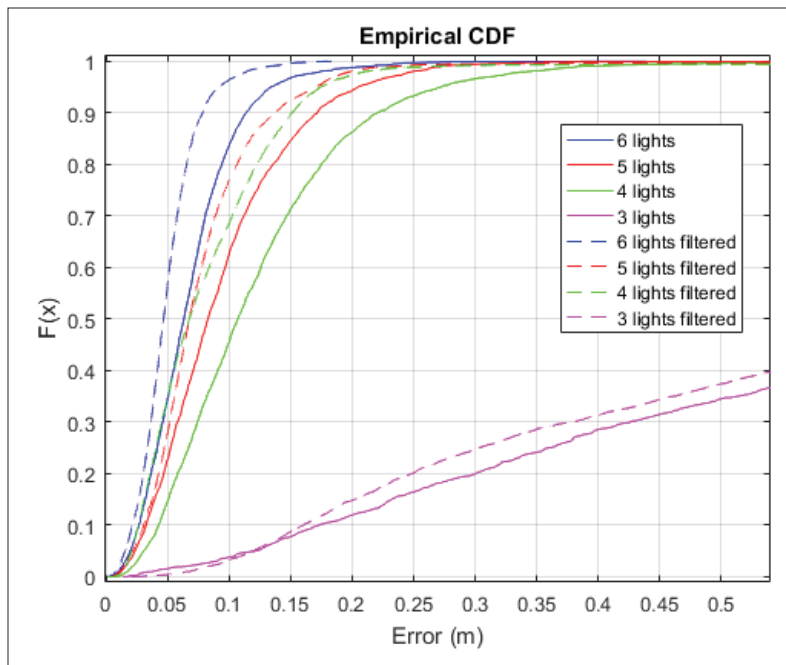

Figure 3. 3D Precision as a function of the number of visible lights and the usage of Kalman filtering on the estimated light positions (filtered).

the advantage that light can be tightly focused to improve the link budget. However, unlike in RF beamforming, the beams cannot be changed dynamically. This means that angular diversity structures including multiple LEDs have to be considered in the system design.

ENERGY EFFICIENT MULTI-DEVICE LiFi MODULATIONS AND MULTIPLE ACCESS SCHEMES

While significant progress is being made in VLC/LiFi research [10], these efforts are not particularly directed at resource constrained devices. Compelling electrical and computing power limitations of the IoT nodes will inform the design of energy efficient modulation and multiple access techniques.

High spectral efficiency modulation techniques such as the discrete multi-tone modulation are undesirable for resource constraint IoT nodes due to its computational needs and high peak-to-average power ratio. Instead, solutions based on pulse based modulation techniques such as the OOK, pulse position modulation (PPM), and PPM variants including spatial PPM (SPPM) [11] are more appropriate. Another energy efficient modulation is the energy efficient random number modulation (RNM) technique proposed in [12]. To achieve energy efficient operation, RNM transmits B bits during a single effective channel-use (i.e., time slot), while a conventional continuous transmission system with M -level modulation technique transmits $\log_2 M$ during every symbol duration. RNM thus approaches conventional modulation techniques as $B \rightarrow \log_2 M$. RNM does not allow for continuous data transmission, hence the link must be tolerant to delays. This technique is therefore attractive for IoT and sensor nodes that only need to send data intermittently.

For the LiFi4IoT AP to communicate effectively with IoT nodes having different kinds of receivers (PD, solar cells and camera) a suitable multiple access technique is required. Designing

such a low power multiple access technique with little or no cross-channel interference is a major challenge. The non-orthogonal multiple access technique (NOMA) recently proposed for LiFi is unlikely to be suitable for LiFi4IoT due to its high computational complexity.

Finally, the development of a common LiFi solution to communicate with both high-speed (e.g., consumer multimedia) and low-speed (e.g., IoT) devices is also a challenge to be addressed. To overlay a low-speed signal on a high-speed signal as done in LTE and NB-IoT would enable a single system solution to address applications with different requirements.

LiFi FOR CMOS RECEIVERS

OCC modulations can be divided into those based on the rolling shutter (RS) effect, which allows a CMOS receiver to demodulate multiple bits from a single image capture, and modulations that transmit at most one bit per frame (non-RS). Consequently, we identify the following two challenges for OCC based data communications: increasing the achievable data-rates to enable new applications, and designing modulations that can be used to communicate simultaneously with RS and non-RS receivers.

OCC data communication solutions proposed in the state of the art achieve data rates around 1 kb/s for RS receivers [13]. We envision several ways to increase these data-rates. First, using RGB LEDs instead of white LEDs would allow to encode independently each color component, while maintaining an acceptable color temperature. Second, while current solutions are mostly based on OOK [14], the use of multi-level amplitude modulation should also be studied. Third, a critical aspect that determines the data-rate in OCC is the amount of screen area illuminated by the modulated LED. Consequently, demodulating ambient light received across the whole CMOS sensor is the most efficient way to increase data-rate. This approach, however, requires more complex image processing to recover the encoded signal from the image background. Finally, interference mitigation techniques are required to increase capacity when various APs in the same room transmit different information. Data rates in the order of tens or hundreds of kb/s are feasible through the previous techniques but only if the receiver is at a reduced distance from the AP (e.g., < 4 meters [14]). Receivers at longer distances should still be able to receive information, if they give up RS operation, that is, communication is achieved by detecting the state of the LED source across different frames captured consecutively. Ideal OCC modulations should be able to address both receiver types, that is, encode a low data-rate signal in non-RS mode for far-away receivers, and allow faster data-rates through the RS effect for closer receivers.

In the field of indoor positioning for OCC, recent solutions based on image processing have achieved cm-level precision in 3D spaces. For example, Fig. 3 depicts the results of an experiment we performed within Mobile World Congress 2016, where a smartphone positions and orientates itself in 3D space, based on codes decoded from LED fixtures. Further research is required to devise new schemes that can provide

3D cm-level precision in the presence of less than four luminaires, which are often not available in practice.

Mechanisms to minimize the impact of the camera sensor on battery life are also critical in OCC. For example, in the case of positioning, one should attempt to maintain accuracy while capturing the minimum number of images. This can be achieved by having algorithms that require a single frame to decode a position, and using inertial sensors to interpolate position data between captured camera frames. For data communication, blank frames can be considered where the camera can be turned off, trading off data-rate with battery duration.

LiFi FOR SOLAR CELL RECEIVERS

The energy-autonomy of the motes depends upon the energy harvested by the solar cell, and the energy requirement of the mote components. The former depends on:

- The illuminance level
- The circuit design that separates the energy harvesting and data communication paths
- The circuit components chosen for energy storage and their interfaces with the solar cell

Currently, for a simple mote such as one with a wake-up communication receiver receiving from a 21kHz OOK modulated LED, the frame success rate is found to be 90 percent at 200 lux and 18 percent at 50 lux with the use of improved energy-efficiency solar cells [3] (under LOS and no-interference conditions). Moreover, 200 lux is required to provide enough power for the wake-up circuitry to function. New circuit designs that improve energy harvesting, while not reducing the data reception accuracy are hence necessary. Efficient energy harvesting and storage solutions should be targeted to allow an energy autonomous functioning of the wake-up receiver circuitry at low light conditions.

Figure 4 illustrates an empirical measurement of the successful reception probability of a wake-up frame at the mote in an office environment for different angles of the solar panel, where 0 corresponds to the case where a solar panel is facing directly toward an 18W LED light. For the details of the wake-up communication, the reader is referred to [3]. As seen in the figure, for typical distances in an office environment, the probability is close to 1 for this energy self-sufficient LiFi wake-up receiver. Even for the extreme case of 180°, there is high reception probability, showing the possibility of communication through the reflected light. Further evaluations show that the effect of light interference, including the one from indirect sunlight, can be mitigated given that the ratio of the light intensity received from the LiFi AP is higher than a solar-cell specific threshold (20 percent-60 percent).

HIGHER-RATE LiFi4IoT RETROREFLECTOR MOTE

At present, retroreflector mote solutions have limited data rates, specifically a maximum bit rate of 15 bps for a conventional camera with 30 fps and sampling at the Nyquist rate. In practice, this problem is even worse because the sampling from conventional cameras is not regular, hence the bit rate has to be reduced even further. New

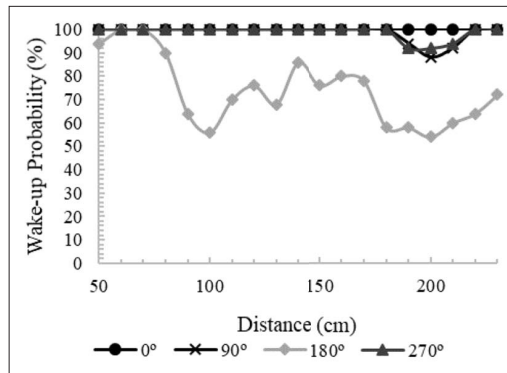

Figure 4. Accuracy of LiFi communication through solar cell.

approaches to improve these limited data rates are crucial. For example, the per-mote data rate can be increased using higher frame rate image sensors and/or multiple synchronized image sensors at the AP. In addition, the use of a CMOS sensor at the AP allows a much higher aggregate uplink data rate through the use of spatial-division multiple access (SDMA).

HIGH SENSITIVITY RECEIVERS FOR LiFi4IoT APs

A fundamental challenge for SPAD receivers is ambient light rejection. Previous research has demonstrated SPAD receivers attaining data rates of 60-100 mb/s at BER of 10^{-3} and sensitivity of -41 dBm albeit in idealized environments. These data rates can be reduced to below 1 mb/s in favor of energy efficient pulsed LED drive schemes at the IoT transmitter, as well as greater ambient rejection. The SPAD sensitivity combined with modulation schemes inspired by lock-in techniques are essential to detect the very low power optical signals in the nW region within a given ambient noise floor, expected from energy limited LiFi4IoT devices.

LiFi4IoT INTEGRATION WITH THE 5G/IP NETWORK

Integration of LiFi4IoT networks and other networks, such as 5G, can be performed at the IP layer. Essentially, the main challenge is to enable and optimize IPv6 support over the LiFi4IoT communications interface (i.e., physical and link layer). This can be achieved by defining an adaptation layer between IPv6 and the LiFi4IoT link layer, which should comprise header compression, optimized neighbor discovery, and fragmentation.

Header compression techniques are required to minimize the packet size when an IPv6 packet is communicated via a LiFi4IoT link. 6LoWPAN header compression is the reference mechanism for constrained devices and should be extended to enable LiFi4IoT [15]. 6LoWPAN neighbor discovery (ND) adapts the IPv6 ND protocol for devices that need to use sleep periods to save energy, thus it is a candidate solution for LiFi4IoT. Finally, if the LiFi4IoT link layer requires a frame format with a maximum payload size below 1280 bytes, then fragmentation is needed to support the IPv6 maximum transmission unit (MTU) requirement.

CONCLUSIONS

In this article, we presented the LiFi4IoT system built on off-the-shelf LEDs as an enabler for the

At present, retroreflector mote solutions have limited data rates, specifically a maximum bit rate of 15 bps for a conventional camera with 30 fps and sampling at the Nyquist rate. In practice, this problem is even worse because the sampling from conventional cameras is not regular, hence the bit rate has to be reduced even further. New approaches to improve these limited data rates are crucial.

Integration of LiFi4IoT networks and other networks, such as 5G, can be performed at the IP layer. Essentially, the main challenge is to enable and optimize IPv6 support over the LiFi4IoT communications interface. This can be achieved by defining an adaptation layer between IPv6 and the LiFi4IoT link layer, which should comprise header compression, optimized neighbor discovery, and fragmentation.

IoT in indoor environments. We described the indoor IoT application space by considering three types of energy self-sufficient motes. The energy-autonomy of these motes is validated in feasibility analyses. These motes employ different LiFi receiver technologies such as CMOS camera sensor, PD, and solar cell, along with low-power LiFi transmitter technologies such as LCD-modulated retroreflector. The choice of the technology depends on the IoT application characteristics. The main research directions that would pave the way to the LiFi4IoT vision are highlighted, in addition to some preliminary results in these directions. The presented LiFi4IoT motes are shown to cover a significant portion of the application types, while promising energy-autonomy, a crucial requirement for many IoT applications.

REFERENCES

- [1] U.S. Department of Energy, "Adoption of Light-Emitting Diodes in Common Lighting Applications," Office of Energy Efficiency and Renewable Energy, Washington, DC, USA, 2017.
- [2] A. O. Korotkevich *et al.*, "On the Comparison of Energy Sources: Feasibility of Radio Frequency and Ambient Light Harvesting," *Renewable Energy*, vol. 81, 2015, pp. 804–07.
- [3] J. S. Ramos *et al.*, "Towards Energy-Autonomous Wake-up Receiver using Visible Light Communication," *IEEE CCNC'16*, Las Vegas, USA, 2016.
- [4] Y.-S. Kuo *et al.*, "Luxapose: Indoor Positioning with Mobile Phones and Visible Light," *Proc. ACM MobiCom*, Maui, HI, USA, 2014.
- [5] T. Borogovac *et al.*, "'Lights-Off' Visible Light Communications," *IEEE GLOBECOM Workshops*, Houston, TX, 2011.
- [6] P. K. Sharma, Y. Jeong, and J. H. Park, "EH-HL: Effective Communication Model by Integrated EH-WSN and Hybrid LiFi/WiFi for IoT," *IEEE Internet of Things J.*, vol. 5, no. 3, June 2018, pp. 1719–26.
- [7] D. Chitnis and S. Collins, "A SPAD-Based Photon Detecting System for Optical Communications," *J. Lightw. Technol.*, vol. 32, no. 10, 2014, p. 2028–34.
- [8] S. Shao, A. Khreishah, and H. Elgala, "Pixelated VLC-Backscattering for Self-Charging Indoor IoT Devices," *IEEE Photonics Technology Lett.*, vol. 29, no. 2, 2017, pp. 177–80.
- [9] M. Kasemann *et al.*, "Photovoltaic Energy Harvesting for Smart Sensor Systems," *Proc. SPIE 8763*, *Smart Sensors, Actuators, and MEMS VI*, 87631T, Grenoble, France, 2013.
- [10] X. Bao *et al.*, "Li-Fi: Light Fidelity—A Survey," *Wireless Networks*, vol. 21, no. 6, 2015, pp. 1879–89.
- [11] W. O. Popoola, E. Poves, and H. Haas, "Spatial Pulse Position Modulation for Optical Communications," *J. Lightwave Technology*, vol. 30, no. 18, 2012, pp. 2948–54.
- [12] A. B. Basnayaka and H. Haas, "A New Degree of Freedom for Energy Efficiency of Digital Communication Systems," *IEEE Trans. Commun.*, vol. 65, no. 7, pp. 3023–36.
- [13] S. Schmid, L. Arquint, and T. R. Gross, "Using Smartphones as Continuous Receivers in a Visible Light Communication System," *Proc. ACM VLCS*, New York City, USA, 2016.
- [14] J. Ferrandiz-Lahuerta, D. Camps-Mur, and J. Paradells-Aspas, "A Reliable Asynchronous Protocol for VLC Communications Based on the Rolling Shutter Effect," *Proc. IEEE GLOBECOM*, San Diego, USA, 2015.
- [15] C. Bormann, "RFC 7400: 6LoWPAN-GHC: Generic Header Compression for IPv6 over Low-Power Wireless Personal Area Networks (6LoWPANs)," *Proc. IETF*, 2014.

BIOGRAPHIES

ILKER DEMIRKOL (ilker.demirkol@upc.edu), IEEE Senior Member, is a Ramon y Cajal Research Professor in the Department of Mining, Industrial and ICT Engineering at the Universitat Politècnica de Catalunya, where he works on wireless networks, covering topics such as cellular systems, IoT, communication protocol development and performance evaluation.

DANIEL CAMPS-MUR (daniel.camps@i2cat.net) is currently leading the Mobile and Wireless Internet group at I2CAT in Barcelona. Previously, he was a senior researcher at NEC Network Laboratories in Heidelberg, Germany. His research interests include mobile networks, Internet of Things, and Software Defined Networking.

JOSEP PARADELLS (josep.paradells@entel.upc.edu) is full professor in the Network Engineering Department of the Universitat Politècnica de Catalunya (UPC). He is the head of the Wireless Network Group and director of the Ubiquitous Internet Technologies Unit at the Fundació I2Cat. His research interests are in wireless systems and Internet access technologies, in particular the evaluation of mobile network protocols.

MARC COMBALIA (marc.combalia@i2cat.net) is currently working on visible light positioning systems in the Mobile and Wireless Internet group in I2CAT in Barcelona. He holds a B.Sc. degree in sciences and technologies of telecommunications from the UPC.

WASIU O. POPOOLA (w.popoola@ed.ac.uk), IEEE Senior Member, has an M.Sc. in optoelectronic and communication systems and a Ph.D. degree in free-space optical communications. He currently holds a chancellor's fellowship at the Institute for Digital Communications, University of Edinburgh. Popoola has over 10 years research experience in optical wireless communications.

HARALD HAAS (h.haas@ed.ac.uk) received the Ph.D. degree from the University of Edinburgh in 2001. He currently holds the Chair of Mobile Communications at the University of Edinburgh, and is the initiator, co-founder and Chief Scientific Officer of pureLiFi Ltd as well as the Director of the LiFi Research and Development Center at the University of Edinburgh. His main research interests are in optical wireless communications, hybrid optical wireless and RF communications, spatial modulation, and interference coordination in wireless networks.