



THE UNIVERSITY *of* EDINBURGH

Edinburgh Research Explorer

**Endothelial Factors in The Pathogenesis and Treatment of Chronic Kidney Disease Part I: General Mechanisms. A Joint Consensus Statement from the ESH Working Group on Endothelin and Endothelial Factors And The Japanese Society of Hypertension**

**Citation for published version:**

Rossi, GP, Seccia, TM, Barton, M, Danser, AHJ, de Leeuw, PW, Dhaun, N, Rizzoni, D, Rossignol, P, Ruilope, L-M, van den Meiracker, AH, Ito, S, Hasebe, N & Webb, D 2017, 'Endothelial Factors in The Pathogenesis and Treatment of Chronic Kidney Disease Part I: General Mechanisms. A Joint Consensus Statement from the ESH Working Group on Endothelin and Endothelial Factors And The Japanese Society of Hypertension', *Journal of Hypertension*. <https://doi.org/10.1097/HJH.0000000000001599>

**Digital Object Identifier (DOI):**

[10.1097/HJH.0000000000001599](https://doi.org/10.1097/HJH.0000000000001599)

**Link:**

[Link to publication record in Edinburgh Research Explorer](#)

**Document Version:**

Peer reviewed version

**Published In:**

Journal of Hypertension

**General rights**

Copyright for the publications made accessible via the Edinburgh Research Explorer is retained by the author(s) and / or other copyright owners and it is a condition of accessing these publications that users recognise and abide by the legal requirements associated with these rights.

**Take down policy**

The University of Edinburgh has made every reasonable effort to ensure that Edinburgh Research Explorer content complies with UK legislation. If you believe that the public display of this file breaches copyright please contact [openaccess@ed.ac.uk](mailto:openaccess@ed.ac.uk) providing details, and we will remove access to the work immediately and investigate your claim.



# Journal of Hypertension

## Endothelial Factors in The Pathogenesis and Treatment of Chronic Kidney Disease Part I: General Mechanisms. A Joint Consensus Statement from the ESH Working Group on Endothelin and Endothelial Factors And The Japanese Society of Hypertension --Manuscript Draft--

<b>Manuscript Number:</b>	JH-D-17-00735R1
<b>Full Title:</b>	Endothelial Factors in The Pathogenesis and Treatment of Chronic Kidney Disease Part I: General Mechanisms. A Joint Consensus Statement from the ESH Working Group on Endothelin and Endothelial Factors And The Japanese Society of Hypertension
<b>Article Type:</b>	Consensus document
<b>Keywords:</b>	artery; atherosclerosis; blood pressure; diabetes mellitus; endothelin; endothelium; hypertension; kidney; nitric oxide; renal failure.
<b>Corresponding Author:</b>	Gian Paolo Rossi, MD, FACC, FAHA University of Padova, Italy Padova, ITALY
<b>Corresponding Author Secondary Information:</b>	
<b>Corresponding Author's Institution:</b>	University of Padova, Italy
<b>Corresponding Author's Secondary Institution:</b>	
<b>First Author:</b>	Gian Paolo Rossi, MD, FACC, FAHA
<b>First Author Secondary Information:</b>	
<b>Order of Authors:</b>	Gian Paolo Rossi, MD, FACC, FAHA Teresa M. Seccia, MD, PhD Matthias Barton, MD, PhD AH Jan Danser, MD, PhD Peter W de Leeuw, MD, PhD Neeraj Dhaun, MD, PhD Damiano Rizzoni, MD, PhD Patrick Rossignol, MD, PhD Luis-Miguel Ruilope, MD, PhD Anton H van den Meiracker, MD, PhD Sadayoshi Ito, MD, PhD Naoyuki Hasebe, MD, PhD David J Webb, MD, PhD
<b>Order of Authors Secondary Information:</b>	
<b>Abstract:</b>	Kidney damage is a common consequence of arterial hypertension, but is also a cause of atherogenesis. Dysfunction and/or harm of the endothelium in glomeruli and tubular interstitium damage the function of these structures and translates into dynamic changes of filtration fraction, with progressive reduction in glomerular filtration rate, expansion of extracellular fluid volume, abnormal ion balance and hypoxia, ultimately leading to chronic kidney disease. Considering the key role played by endothelial dysfunction in chronic kidney disease, the Working Group on Endothelin and Endothelial Factors of the European Society of Hypertension and the Japanese

Society of Hypertension have critically reviewed available knowledge on the mechanisms underlying endothelial cell injury. This resulted into two manuscripts: in the first we herein examine the mechanisms by which endothelial factors induce vascular remodeling and the role of different players, including endothelin-1, the renin-angiotensin-aldosterone system and their interactions, and of oxidative stress; in the second we discuss the role of endothelial dysfunction in the major conditions that affect the kidney.

Prof. Alberto Zanchetti  
*Editor-in-Chief*  
Journal of Hypertension

Padova, September 5th, 2017

Dear Prof. Zanchetti,

Thank you for your letter of August 1st concerning the manuscript "Endothelial Factors in The Pathogenesis and Treatment of Chronic Kidney Disease Part I: General Mechanisms" (**JH-D-17-00735**).

We valued much the Reviewers' constructive criticisms and implemented all suggested changes. To ease their tracking in the revised version the changes made are highlighted in yellow in the text. We believe that after this revision the manuscript has been improved considerably and can therefore receive a positive evaluation in the present form.

Therefore, on behalf of my coworkers, I would like to submit the revised version of for consideration for publication in Journal of Hypertension.

We are grateful for the additional consideration to our work and remain your sincerely.

Kindest regards,

Gian Paolo Rossi, FAHA, FACC  
Clinica dell'Ipertensione  
Department of Medicine – DIMED  
University Hospital  
35128 Padova, Italy  
gianpaolo.rossi@unipd.it

## Reviewer Comments:

### Reviewer #1:

This is a timely review on an important issue for the high cardiovascular and renal risk of CKD patients. The authors' team is composed by internationally respected investigators.

I have the following suggestions for the authors of this review:

*1. The authors have apparently adopted a systematic approach to the review (defined as a "consensus statement"). They indeed say ... "we searched the PubMed and Google Scholar databases using a Boolean strategy for knowledge generated within these fields over the past decade. Those studies providing important novel mechanistic information were selected and incorporated into the current consensus statement." All searches made in PubMed and Google are inherently Boolean and therefore the term may be dropped with a gain in clarity.*

*The authors should rather specify the "search terms" and their combination they adopted for extracting pertinent literature. To this scope the authors may consult the PRIMA recommendations for systematic reviews by EQUATOR, <http://www.prisma-statement.org/documents/PRISMA-P-checklist.pdf> . As it is customary, the "Search Strategy" can be illustrated into detail in a BOX.*

*Even though this referee recognizes that there is an important element of subjectivity in the selection of what it is perceived as "novel mechanistic information", a small effort for setting minimal criteria for "novelty" would render this review more objective. This is important because as much as 43 papers (out of 110) quoted in the review are >10 years older. Furthermore References include over 20 narrative reviews, some of which pretty old, which makes difficult for the readers to understand how "novelties" were captured.*

*If the authors do not pretend to have done a "systematic review" they may simply qualify their review as a narrative, unsystematic review. Also in this case I would suggest that they neatly declare their search strategy and the selection process adopted as it is commonly done in (invited) narrative reviews in major journal (for example: *The Lancet* 2016; 388: 285-93).*

**RE:** We appreciated a lot the Reviewer's criticisms, which helped us in improving the manuscript. As you suggested, we dropped the term 'Boolean strategy' because of the huge amount of studies published on the endothelium in the last three decades, selection of the articles was indeed a hard task. As reported in detail in the text, after retrieving a great number of articles, we refined our search applying the following criteria: a) appropriateness of methodologies; b) novelty; c) relevance for understanding mechanisms and/or clinical practice; d) expertise of the authors in the field; e) source of publication.

Hence, details are now reported in the new paragraph "Methodology and search literature" and MeSH terms in Table 1.

*2. The Introduction is fairly elaborate and repeats general concepts summarized in several reviews on endothelial function (e.g. *Circulation*. 2012;126:753-67). This introductory part may be easily compacted and reduced by the 50% or so, perhaps also quoting the above mentioned *Circulation* review.*

**RE:** The introduction has been markedly shortened and the *Circulation* review has been quoted.

*3. The section focusing on MR interference with endothelial function is inflated (819 words, see also point 3, below) as compared to other fundamental sections (1314 words dedicated Endothelin, RAS and NO and the interaction of these factors).*

**RE:** We followed your suggestion of cutting the section on MR by 15%: the revised version now entails 695 words.

*4. One of the most exciting mechanistic novelties about endothelial function of the last decade is the discovery that the endothelial glycocalyx acts a negatively charged biopolymer selectively buffering sodium ions (Pflugers Arch , 2011, vol. 462 : 519-528 ). This issue is of relevance for the integration of vascular tone, renal perfusion and regulation of renal sodium reabsorption in health and disease (*Nat Rev Nephrol*. 2014;10:146-*

57). The authors quoted 5 papers by Oberleithner related with this issue in the second section (aldosterone and the endothelium). This a fundamental mechanism which may deserve to be illustrated into a separate subsection also expanding on its potential relevance in the pathophysiology of CKD.

**RE:** We thank the Reviewer for his/her precious suggestion. We created a new section on glycocalyx, which included the effects of aldosterone and the articles suggested by the Reviewer.

**Reviewer #2:**

*The authors have written a very nice review of the pathophysiological implications of the endothelium and endothelial dysfunction in renal physiology and renal diseases. The paper is easy to read, well illustrated and instructive.*

*There are only minor comments to this paper:*

*1. In page 6, the authors mention that endothelial function or dysfunction affects the entire vasculature including glomeruli and tubuli. Although it is true that tubular function is affected, this is mainly indirectly or as an effect on non vascular cells. Tubuli do not belong to the vasculature. The sentence should be modified.*

**RE:** We apologize for the error, which was corrected.

*2. When the authors discuss the effects of endothelin antagonists on BP and proteinuria and renal function, can they also discuss the potential of the endothelium in mediating the endothelin-antagonists-induced peripheral oedema which may occur anywhere in the body and thus are different from calcium channel blockers-induced edema. Is there a link with endothelial function?*

**RE:** We thank for the suggestion. We added a comment on the edema-associated ET<sub>A</sub> receptor blockade, which is deemed to be caused mostly by ET<sub>B</sub> receptor activation.

*3. Another characteristic of CKD and vasculature is vascular rarefaction which has been shown in the skin but also within the kidney. Can the authors discuss the potential role of the endothelium in this vascular rarefaction?*

**RE:** It is well known that tubulointerstitial fibrosis is associated with capillary rarefaction in CKD. In mice ablation of exon 4 in endothelial Sirt1 gene, which codes for sirtuin 1 (SIRT1), an NAD<sup>+</sup>-dependent deacetylase controlling growth and senescence, impairs endothelium-dependent vasorelaxation and enhances Notch1 signalling, blunting angiogenesis (Kida et al. *BBRC* 2016; Vasko et al. *JASN* 2014). Hence, a link between capillary rarefaction and endothelium exists, but if and what endothelial factor(s) affect(s) capillary rarefaction is totally unknown. Although of great interest, because of the limited space, we decided to not include such information.

*At last, some coauthors are members of the ESH Working Group on the Kidney. It is a pity that this working group was not involved in this very nice work*

**RE:** We fully understand this regret but there are at least four distinguished Nephrologists in our WG, which are part of the WG that the Reviewer mentioned.

## **Abbreviations**

Ang II: angiotensin II

ACE: angiotensin I converting enzyme

ADMA: asymmetric dimethylarginine

ARB: angiotensin AT<sub>1</sub> receptor blocker

BP: blood pressure

CKD: chronic kidney disease

CV: cardiovascular

ECE: endothelin converting enzyme

EDH: endothelium-derived hyperpolarization

eGFR: estimated glomerular filtration rate

EMT: epithelial to mesenchymal transition

ENaC: epithelial or endothelial Na<sup>+</sup> channel

ERA: endothelin receptor antagonist

eNOS: endothelial nitric oxide synthase

ESRD: end-stage renal disease

ET-1: endothelin-1

GPER: G protein-coupled estrogen receptor

GFR: glomerular filtration rate

HIF-1: hypoxia-inducible factor-1

iNOS: inflammatory nitric oxide synthase, NOS 2

L-NMMA: N(G) monomethyl-L-arginine

NO: nitric oxide

NOS: nitric oxide synthase

PIP<sub>3</sub>: phosphatidyl-inositol (3,4,5) trisphosphate

RAAS: renin-angiotensin-aldosterone system

ROS: reactive oxygen species

VSMC: vascular smooth muscle cells

## **Condensed abstract**

Dysfunction and/or loss of the endothelium in the renal glomeruli and tubular interstitium progressively lead to chronic kidney disease. In this consensus statement the Working Group on Endothelin and Endothelial Factors of the European Society of Hypertension and the Japanese Society of Hypertension critically review knowledge on the mechanisms underlying endothelial cell injury. In Part I we examine the mechanisms by which endothelial factors induce vascular remodeling and the role of different players, including endothelin-1, the renin-angiotensin-aldosterone system and their interactions, and of oxidative stress. In Part II we discuss the endothelial dysfunction in the major conditions that affect the kidney.



**Endothelial Factors in The Pathogenesis and Treatment  
of Chronic Kidney Disease Part I: General Mechanisms.  
*A Joint Consensus Statement from the ESH Working Group on Endothelin and  
Endothelial Factors And The Japanese Society of Hypertension***

Gian Paolo Rossi<sup>1</sup>, Teresa M. Seccia<sup>1</sup>, Matthias Barton<sup>2</sup>, AH Jan Danser<sup>3</sup>, Peter W. de Leeuw<sup>4</sup>,  
Neeraj Dhaun<sup>5</sup>, Damiano Rizzoni<sup>6</sup>, Patrick Rossignol<sup>7</sup>, Luis-Miguel Ruilope<sup>8</sup>,  
Anton H. van den Meiracker<sup>3</sup>, Sadayoshi Ito<sup>9</sup>, Naoyuki Hasebe<sup>10</sup>, David J. Webb<sup>5</sup>

<sup>1</sup>Department of Medicine – DIMED, University of Padova, Italy; <sup>2</sup>Molecular Internal Medicine, University of Zürich, Zürich, Switzerland; <sup>3</sup>Division of Pharmacology and Vascular Medicine, Department of Internal Medicine, Erasmus Rotterdam, The Netherlands; <sup>4</sup>Department of Medicine, Maastricht University Medical Center and Cardiovascular Research Institute Maastricht, Maastricht and Department of Medicine, Zuyderland Medical Center, Geleen/Heerlen, The Netherlands; <sup>5</sup>University/British Heart Foundation Centre of Research Excellence, Queen's Medical Research Institute, University of Edinburgh, Scotland, UK; <sup>6</sup>Department of Clinical and Experimental Sciences, University of Brescia, and Division of Medicine, Istituto Clinico Città di Brescia, Brescia, Italy; <sup>7</sup>Inserm, Centre d'Investigations Cliniques-Plurithématique 14-33, Inserm U1116, CHU Nancy, Université de Lorraine, Association Lorraine de Traitement de l'Insuffisance Rénale, and F-CRIN INI-CRCT (Cardiovascular and Renal Clinical Trialists), Nancy, France; <sup>8</sup>Hypertension Unit, Hospital 12 de Octubre; Department of Postdoctoral Medicine and Investigation, Universidad de Europa; Department of Public Health and Preventive Medicine, Universidad Autonomy, Madrid Spain; <sup>9</sup>Division of Nephrology, Endocrinology and Hypertension, Tohoku University Graduate School of Medicine, Japan; <sup>10</sup>Division of Cardiology, Nephrology, Pulmonology and Neurology, Asahikawa Medical University, Japan.

Word count: 9324 (including title page, references and captions to the figures)

Abstract: 164 words

Number of figures: 5

Supplemental table: 1

Correspondence:

Gian Paolo Rossi, MD, FACC, FAHA  
Clinica dell'Ipertensione Arteriosa  
Department of Medicine-DIMED  
University Hospital  
Via Giustiniani, 2  
35128 Padova, Italy  
Phone: +39-049-821-7821  
gianpaolo.rossi@unipd.it

## **Abstract**

Kidney damage is a common consequence of arterial hypertension, but is also a cause of atherogenesis. Dysfunction and/or harm of the endothelium in glomeruli and tubular interstitium damage the function of these structures and translates into dynamic changes of filtration fraction, with progressive reduction in glomerular filtration rate, expansion of extracellular fluid volume, abnormal ion balance and hypoxia, ultimately leading to chronic kidney disease. Considering the key role played by endothelial dysfunction in chronic kidney disease, the Working Group on Endothelin and Endothelial Factors of the European Society of Hypertension and the Japanese Society of Hypertension have critically reviewed available knowledge on the mechanisms underlying endothelial cell injury. This resulted into two manuscripts: in the first we herein examine the mechanisms by which endothelial factors induce vascular remodeling and the role of different players, including endothelin-1, the renin-angiotensin-aldosterone system and their interactions, and of oxidative stress; in the second we discuss the role of endothelial dysfunction in the major conditions that affect the kidney.

**Key Words:** artery; atherosclerosis; blood pressure; diabetes mellitus; endothelin; endothelium; hypertension; kidney; nitric oxide; renal failure.

## **Abbreviations**

Ang II: angiotensin II

ACE: angiotensin I converting enzyme

ADMA: asymmetric dimethylarginine

ARB: angiotensin AT<sub>1</sub> receptor blocker

BP: blood pressure

CKD: chronic kidney disease

CV: cardiovascular

ECE: endothelin converting enzyme

EDH: endothelium-derived hyperpolarization

eGFR: estimated glomerular filtration rate

EMT: epithelial to mesenchymal transition

ENaC: epithelial or endothelial Na<sup>+</sup> channel

ERA: endothelin receptor antagonist

eNOS: endothelial nitric oxide synthase

ESRD: end-stage renal disease

ET-1: endothelin-1

GPGR: G protein-coupled estrogen receptor

GFR: glomerular filtration rate

HIF-1: hypoxia-inducible factor-1

iNOS: inflammatory nitric oxide synthase, NOS 2

L-NMMA: N(G) monomethyl-L-arginine

NO: nitric oxide

NOS: nitric oxide synthase

PIP<sub>3</sub>: phosphatidyl-inositol (3,4,5) trisphosphate

RAAS: renin-angiotensin-aldosterone system

ROS: reactive oxygen species

VSMC: vascular smooth muscle cells

## **Table of Contents**

1. Introduction
2. Endothelium-derived mechanisms and kidney injury
3. Aldosterone-mediated impairment of endothelium-dependent vasodilation
4. Endothelin-1 in hypertension and renal damage
5. Endothelial Glycocalyx
6. Interactions between the renin angiotensin aldosterone system, endothelin-1 and nitric oxide in the kidney
7. Renal fibrosis in CKD: role of endothelial factors and oxidative stress
8. Other endothelial factors in renal vascular remodeling
9. Conclusions

## 1. Introduction

Arterial hypertension is the most prevalent modifiable cardiovascular (CV) disease risk factor and contributes significantly to global disease burden [1,2]. It is often associated with chronic kidney disease (CKD), which is also an independent risk factor for atherogenesis [3], an important determinant of overall CV risk [4,5]. Renal vasoconstriction and/or impaired Na<sup>+</sup> excretion are hallmarks of the early stages of both hypertension and CKD, thus implicating a key role for the kidney in the development of hypertension. CKD patients are at increased risk of hypertension, coronary artery disease and stroke, which are all major causes of death in these patients even before the development of end-stage renal disease [6]. Thus, the CKD is both a cause and consequence of hypertension [7].

For decades the endothelium was regarded as an inactive layer lining the vessels [8]. However, after the pioneering work of many investigators, including the Nobel laureates Robert Furchgott [9], Louis Ignarro and Ferid Murad, who discovered endothelium-derived vasodilating factor nitric oxide (NO)[10], Paul Vanhoutte and Jo de Mey [11] who described endothelium-dependent vasoconstriction then characterized by Hickey et al. [12], and the discoverers of endothelin-1 (ET-1) Masashi Yanagisawa and Tomoh Masaki [13], it became clear that the endothelium is key for the preservation of vascular integrity. In effect, with a weight in an adult man similar to that of the liver and a surface area throughout the body comparable to that of four tennis courts, it represents the largest organ in the body [8].

Impaired endothelium-dependent vasodilation is a hallmark of many CV disease risk factors and conditions besides hypertension, suggesting that it can be an early mechanism leading to CV damage or, alternatively, a marker of it [14]. Endothelial dysfunction, which involves the entire vascular tree and implies a shift towards a pro-inflammatory pro-thrombotic state [15], also affects the renal vasculature. Given the specific function of glomerules and tubules (e.g. plasma ultrafiltration, ion reabsorption and cell acidification), endothelial loss and/or dysfunction translates into dynamic changes of filtration fraction, resulting in a progressive reduction in the glomerular filtration rate (GFR), extracellular fluid volume expansion, abnormal ion balance and renal hypoxia, all of which ultimately lead to CKD.

Recognizing the key roles played by the endothelium in cardio-renal health, as well as the lack of up to date information on its role in CKD, the Working Group on Endothelin and Endothelial Factors of the European Society of Hypertension (ESH) in conjunction with the Japanese Society of Hypertension (JSH) prepared this consensus document to summarize current knowledge of the mechanisms underlying endothelial cell injury and its role in renal damage in arterial hypertension, diabetes mellitus, preeclampsia, kidney transplantation, and cancer patients undergoing antiangiogenic therapy. Part I is focused on the general mechanisms underlying endothelial dysfunction in the kidney; Part II will discuss the role of endothelium in CV and metabolic diseases.

**Methodology and literature search.** Each section was assigned to one or two Authors, who were responsible for the initial search and selection of the retrieved articles. Each Author searched the PubMed and Google Scholar databases (<http://libguides.mit.edu/c.php?g=175963&p=1158594>) for knowledge generated within these fields over the past decade using the MeSH terms reported in Supplemental Table 1. Only papers written in English language were considered. Besides the articles identified by such strategy, the reference lists of previous reviews published on this topic were examined. Seminal papers, even though published more than one decade ago, or review articles were quoted if considered fundamental for the present review. Criteria used for selection of the retrieved articles were *a)* appropriateness of methodologies; *b)* novelty; *c)* relevance for understanding mechanisms and/or for clinical practice; *d)* expertise of the authors in the field; *e)* source of publication. Then, to offer a coherent narrative rather than a descriptive review, the manuscript was reviewed by each other Author, who also critically evaluated literature. A thematic cross-disciplinary (internal medicine, nephrology, pharmacy) approach was chosen to avoid a bias towards a specific discipline.

## **2. Endothelium-dependent mechanisms and kidney injury**

Mechanical stress, hypoxia, aging, smoking, hypercholesterolemia, diabetes mellitus, and hyperhomocysteinemia all lead to an increased formation of reactive oxygen species (ROS), which inactivate NO and increase the formation of vasoconstricting and mitogenic substances. This results in an imbalance between vasodilating and vasoconstricting endothelial factors (Figure 1). A decreased

bioavailability of NO and/or an increased release of NO inhibitors, such as asymmetric dimethylarginine (ADMA), reduce NO bioactivity on the renal vascular smooth muscle cells (VSMC) blunting vasodilation (Figure 1)[16–18]. A reduced release of endothelium-derived hyperpolarizing factors (EDHF) (like epoxyeicosatrienoic acids) reduces K<sup>+</sup> channels activity, and promotes Ca<sup>2+</sup> influx, thus activating VSMC contraction (Figure 1). When the release of the vasodilators NO and EDHF is blunted, angiotensin II (Ang II) and ET-1 act unopposed to induce renal and systemic vasoconstriction. This leads to reduced renal blood flow and hypoxia, with ensuing activation of the renin-angiotensin-aldosterone system (RAAS)[19]. The negative feedback mechanism whereby Ang II suppresses renin release might modulate this RAAS activation, but the effectiveness of this counter-regulation in different clinical settings is far from established.

Moreover, hypoxia inhibits NO synthesis and facilitates formation of hypoxia-inducible factor-1 (HIF-1) and ROS, which, via inflammatory nitric oxide synthase (iNOS), promote generation of large amounts of NO in leukocytes, VSMCs, and epithelial tubular cells. This gives rise to the formation of peroxynitrite, which aggravates microcirculatory dysfunction [20], and possibly also to destabilization of atherosclerotic plaques, as peroxynitrite activates matrix metalloproteinases (Figure 1)[21].

The production of the potent vasoconstrictor ET-1 is triggered by multiple stimuli, including Ang II, ROS, and pro-inflammatory cytokines [22]. Under pathophysiological conditions, this can take place in renal cells other than the endothelial cells, including podocytes, epithelial and mesangial cells [23](Figure 2). Endothelial cells secrete ET-1 predominantly towards the abluminal side, where ET<sub>A</sub> and ET<sub>B</sub> receptors (under disease conditions) are located, thereby triggering vasoconstriction and cell proliferation. Thus, ET-1 induces contraction and growth by acting in a paracrine fashion on VSMCs. ET-1 also releases NO and prostacyclin by acting in an autocrine fashion on the ET<sub>B</sub> subtypes of endothelial cells [24].

In the kidney ET-1 increases renal vascular resistance and reduces glomerular filtration rate, but also water and Na<sup>+</sup> absorption in the collecting duct mostly via activation of ET<sub>B</sub> receptors; ET<sub>B</sub> also mediate ET-1 clearance, which may occur in the kidney [25]. Excess ET-1 disrupts the actin cytoskeleton in the glomeruli via ET<sub>A</sub> receptors, favoring proteinuria, glomerulosclerosis, and apoptosis of tubular epithelial

cell with ensuing hypoxia and inflammation [26–28].

### 3. Aldosterone-mediated impairment of endothelium-dependent vasodilation

Aldosterone is produced by the adrenocortical zona glomerulosa and to a lesser extent locally by vascular endothelial and smooth muscle cells, mesangial cells, and cardiomyocytes [29–35]. By acting via nuclear and cytoplasmic mineralocorticoid receptors [36,37], it regulates vascular tone and vascular, myocardial and renal structure. Mineralocorticoid receptor activation induces both vasoconstriction and vasodilation. The latter involves phosphatidylinositol 3 (PIP3) kinase dependent activation of NOS in the endothelial cells, a rapid effect that is held to be non-genomic because it is insensitive to inhibitors of gene transcription or protein synthesis [38–41]. Thus, the rapid nongenomic effects are crucially regulated by the endothelial (dys)function: if endothelial function is intact aldosterone exerts vasodilatation and increase GFR, whereas when the endothelial function is impaired with blunted endothelial NOS (eNOS) activity, aldosterone causes vasoconstriction, decreased renal plasma flow and increased renal vascular resistance [39,41]. The vasoconstricting effect, even in both afferent and efferent arterioles, is more pronounced in the efferent arteriole [39].

Recent evidence suggests that some effects of aldosterone involve a cross-talk between the mineralocorticoid receptor and the G protein-coupled estrogen receptor (GPER)[42][37]. When infused into dogs, in which renal perfusion pressure was clamped to 19 mmHg, aldosterone [14 µg/kg/day] was found to cause hyperfiltration [43]. This finding can explain the hyperfiltration seen in human primary aldosteronism, and the apparent worsening of eGFR after cure of the hyperaldosteronism with adrenalectomy [44]; however, the correction of hypervolemia after adrenalectomy may also play a role.

A mineralocorticoid receptor-mediated aldosterone-induced vasoconstriction has been observed in healthy humans in the forearm [38]. However, if co-infused with the inhibitor of endothelial NOS (eNOS) N(G) monomethyl-L-arginine (L-NMMA), aldosterone [500 µg i.v.] increases renal vascular resistance, with a more pronounced effect on the afferent than the efferent arteriole [41]. Aldosterone regulates Na<sup>+</sup> channels in the endothelium, as it does in the distal tubular epithelial cells and collecting duct [45], and causes endothelial cell swelling, an effect abolished by the ENaC blocker amiloride [46]. It also increases



ENaC, a target of aldosterone in distal tubular epithelial cells (see above) and promotes its insertion to the membrane [47] via both genomic and non-genomic effects [45,47–49].

Mice with a specific knock-out of the mineralocorticoid receptor in endothelial cells alone represent an optimal model to investigate the role of this receptor. In this model a pronounced vasoconstriction was found in coronary but not mesenteric arterioles after exposure to ET-1, despite no change in blood pressure (BP) or renal Na<sup>+</sup> handling [50]. Whether endothelial mineralocorticoid regulates renal hemodynamics remains unclear. However, mice with targeted deletion of mineralocorticoid receptors in vascular smooth muscle, or in endothelial cells, show that only the receptor in the former cells is crucial for the hemodynamic alterations that lead to acute kidney injury induced by subcutaneous cyclosporine administration. Hence, aldosterone, via the mineralocorticoid receptor, promotes microvascular contraction, thereby potentiating the effect of cyclosporine-induced NO deficiency [51].

Furthermore, in the model of acute kidney injury induced by pedicle clamping, the ischemic injury was prevented by antagonizing the mineralocorticoid receptor [52]. Ischemia-induced oxidative stress and cysteine sulfenic acid modification of endothelial cell ET<sub>B</sub> receptors causing blunted activation of eNOS, were prevented by the mineralocorticoid receptor antagonist [52].

In endothelial cells, aldosterone can also increase the expression of F-actin myofilaments, which, combined to G-actin myofilaments, form a web beneath the membrane that dynamically regulates the lumen caliber [46]. An increased F-to-G-actin myofilament ratio leads to web polymerization with ensuing cell 'stiffening' and decreased NO production [46]. Hence, aldosterone may potently cause renal vasoconstrictor acting via both endothelium stiffening and decreased NO bioactivity. Both Ang II, via Ang II type 1 (AT<sub>1</sub>) receptors, and endothelin-1, via ET<sub>A</sub> receptors, mediate the effects of aldosterone infusion on blood pressure and end-organ injury [53,54]. T-lymphocytes have also been implicated in aldosterone-mediated effects [55]. Of note, human primary aldosteronism is associated with microalbuminuria, a marker of early endothelial dysfunction, which persists even after correction of hyperfiltration [56], but regresses when primary aldosteronism is cured with adrenalectomy [57].

#### **4. Endothelin-1 (ET-1) in hypertension and renal damage**

ET-1 contributes to the regulation of vascular tone and blood pressure (BP) [58], and to a multitude of other physiological processes, including cell proliferation, endothelial dysfunction, arterial stiffness, cardiac hypertrophy and tissue fibrosis via epithelial to mesenchymal transition (EMT), and also turns on aldosterone secretion, all of which contribute to the development and maintenance of hypertension and its detrimental consequences [59,60]. Vascular production of ET-1 is increased in most salt-sensitive animal models of hypertension [61]. Notably, the pressor effects of ET-1 appear to be, at least in part, dependent on salt, as chronic infusion of a subpressor dose of ET-1 increases BP only when combined with a normal or high sodium diet [62].

By inducing vasoconstriction, vascular remodeling, and decreasing arterial compliance, ET-1 enhances arterial pulse wave reflection and central pressure augmentation, contributing to arterial stiffening, resulting in a reduced capacity of buffering pressure and pulsatile flow oscillations [63]. Arterial stiffness is independently associated with mortality in end-stage renal disease (ESRD) patients, and, moreover, worsens rapidly over time in those in hemodialysis [64]. Moreover, infusion of ET-1 in healthy humans to increase plasma levels to those seen in ESRD was found to be associated with significant increases in pulse wave velocity, central systolic pressure and pulse pressure [65].

In experimental models of hypertension associated with an increase in ET-1, both selective ET<sub>A</sub> and non-selective ET<sub>A/B</sub> receptor antagonists effectively reduce BP [62]. Importantly, selective ET<sub>A</sub> receptor blockade prevents endothelial cell dysfunction, vascular hypertrophy, and glomerular sclerosis in salt-dependent genetic hypertension, even when high blood pressure is not fully corrected, suggesting blood pressure-independent beneficial effects of the treatment [60,66–68].

In hypertensive patients circulating ET-1 levels were found to be increased compared to healthy individuals in some, but not all, reports [69]. According to studies with ET receptor antagonists (ERAs) both selective and non selective ERAs increase forearm vasodilation and reduce BP more in hypertensive patients than in healthy individuals [69]. Finally, even though several chronic studies have suggested that both ET<sub>A</sub>-selective and non-selective ET<sub>A/B</sub> ERAs can reduce BP [69], no direct head-to-head comparison of

the two approaches is available. In CKD plasma ET-1 is increased [70], likely because of augmented production and reduced clearance. Notably, urinary excretion of ET-1, reflecting renal production, increases as renal function declines [70], suggesting that this over activation of the renal ET system contributes to hypertension and to worsening of renal function.

In hypertensive non-diabetic CKD patients acute ET<sub>A</sub> receptor blockade reduces BP by about 10 mmHg [71], a decrease that is attenuated by concomitant ET<sub>B</sub> receptor antagonism [72], suggesting that vasoconstrictor ET<sub>B</sub> receptor activity is less important than ET<sub>B</sub> vasodilatory and ET-1 clearance function, at least in this condition. In a similar patient population, chronic ET<sub>A</sub> receptor antagonism also reduces BP, albeit to a lesser extent [73]. Interestingly, in both acute and chronic studies [71,73] the majority of the patients studied were already taking Ang I converting enzyme (ACE) inhibitors, which is important clinically because after the publication of the RENAAL, IRMA-1 and IRMA-2 studies [74–76], CKD patients are generally prescribed RAAS inhibitors, not only for BP control but also for their microalbuminuria lowering effects. Limited data with non-selective ET<sub>A/B</sub> antagonism suggest that this approach may also be beneficial in lowering BP in non-diabetic CKD patients [77]. Proteinuria, a manifestation of dysfunction of the glomerular filtration barrier, and podocyte injury, a marker of glomerular hypertension, are associated with increased CV risk. Both acute [71,78] and chronic [73] selective ET<sub>A</sub> receptor blockade and non-selective ET<sub>A/B</sub> antagonism [77] reduce proteinuria in patients with non-diabetic CKD. In the acute studies these beneficial effects were abolished by concomitant ET<sub>B</sub> receptor antagonism [78], suggesting that they involve ET<sub>B</sub> receptor activation. ET<sub>B</sub> receptors are also deemed to be responsible for the fluid retention and increased vascular permeability, leading to edema, an effect commonly observed after ET<sub>A</sub> receptor blockade possibly resulting from ET<sub>B</sub> receptor activation [79].

The mechanisms underlying proteinuria and its reduction by AT<sub>1</sub> receptor blockers (ARBs), ACE inhibitors, and ERAs will be discussed in Part II.

High blood pressure favours heart failure and CKD, which in turn leads to hypertension and CV disease. Hence, there is a relationship between the heart and the kidney, usually referred to, albeit improperly because the underlying pathophysiology is not clearly known, as “cardiorenal syndrome”. Endothelial

dysfunction occurs in both heart failure and CKD, but whether it is amplified in the cardiorenal syndrome remains to be elucidated [80].

## 5. Endothelial Glycocalyx

The endothelial cell surface is coated with proteoglycans covalently bound to polysaccharide chains synthesized in the endothelial cells [81]. Sulfation of its components, mostly heparan and chondroitin sulfates, makes the glycocalyx a negatively charged gel-like surface. The endothelial glycocalyx provides a passive barrier to water and solute transport, which regulates vascular permeability, and the interaction between endothelial and circulating cells, as leukocyte [81]. In the kidney the densely packed hyaluronan in the glycocalyx, by anchoring to the glomerular basement membrane, fills the fenestrae of endothelium [82], thus preventing filtration of albumin [83], which is close in size to that of the spaces between the glycosaminoglycan fibres (for a rev. see [84]).

Factors that injury endothelium also induce sulfation and deacetylation of heparan sulfate in the glycocalyx, increase the expression of glycoproteins, as selectins and integrins, and activate enzymes, as heparanase and hyaluronidase II that degrade the glycocalyx [85,86]. The increased heparanase activity found in diabetic nephropathy [87,88], alongside the prevention of renal damage in heparanase KO mice [84] supports a protective role of the glycocalyx in diabetic nephropathy. Moreover, endothelium-derived factors, as ET-1, can activate heparanase in podocytes, with loss of the glycocalyx. The evidence that podocyte-specific knockout of both ET<sub>A</sub> and ET<sub>B</sub> receptor subtypes in mice prevented the reduction of heparan sulfate and endothelial glycocalyx thickness, and the development of proteinuria, supports the harmful role of ET-1 for glycocalyx [87].

Excess aldosterone can also affect glycocalyx by enhancing Na<sup>+</sup> binding to glycocalyx, thus saturating its negative surface charges and increasing adhesion of red blood cells, an effect that can be prevented by spironolactone [46]. Hence, aldosterone not only renders the endothelial cells stiffer (see above section 3), but also stiffer, finally leading to endothelial damage and vasoconstriction [89].

## 6. Interactions between the RAAS, ET-1, and NO in the kidney

The RAAS, ET-1 and NO interact in a complex fashion (Figure 3)[90]: Ang II was shown to stimulate the expression or release of ET-1 in endothelial cells *in vitro*, and to increase ET-1 production in the kidney [22,91]. It also up-regulates the expression of the ET<sub>A</sub> receptor [92] and the binding of ET-1 to this receptor in endothelial cells *in vitro* [93], and in the kidney *in vivo*. In contrast to Ang II, which whilst constricting all intra-renal vessels has its most prominent effects on the post-glomerular vessels, ET-1 causes mainly pre-glomerular constriction (Figure 4)[62]. Further actions of the two peptides that occur in parallel in the kidney are mesangial cell contraction, extracellular matrix production, and enhanced tubular Na<sup>+</sup> absorption (ET-1 stimulates sodium excretion via stimulation of the ET<sub>B</sub> receptor in proximal tubules, see above), an effect that can be enhanced by the secretagogue actions of both peptides on aldosterone [94].

In transgenic animals overexpressing renin with fulminant Ang II-dependent hypertension, ET-1 was shown to promote renal fibrosis by activating endothelial-to-mesenchymal transition (EMT)[95], a process by which endothelial cells lose their markers and acquire those of mesenchymal cells, thus transforming into collagen producing myofibroblasts [96]. This process leads to microvascular rarefaction and fibrosis, with consequent hypoxia that threatens endothelial cell repair and regeneration [72].

Glomerular endothelial cell crosstalk with parietal and glomerular epithelial cells (i.e. the epithelial cells that constitute the outer part of the Bowman's capsule and the podocytes, respectively), which release ET-1, Ang II, ROS, cytokines, and other stress-signaling molecules, thus amplifying the injury [97,98]. Figure 3 summarizes this cross-talk and Figure 2 shows the role of ET-1 in this process (Fig 2 from [98]). An injured endothelium drives innate immunity and inflammation, with complement activation and platelet dysfunction, which further enhance the damage [97,99]. Hence, without any safeguard mechanisms the combined action of Ang II and ET-1 would render the kidney ischemic and fibrotic in a short period of time. However, both systems can also play a protective role by inducing vasodilation and natriuresis and inhibiting fibrosis, either acting directly or through stimulation of NO production. Ang II can raise NO via intra-renal Ang II type 2 (AT<sub>2</sub>) receptors, while ET-1 does so by activating ET<sub>B</sub> receptors.

Thus, it is conceivable that both ET-1 and Ang II, or at least its protective breakdown product, Ang 1-7 [100], can also play beneficial effects. Ang 1-7, which is made from Ang I through ACE2 action, can activate eNOS and release of NO via the G-protein-coupled Mas receptor [101]. Notably, Ang II, ET-1, and NO all inhibit renin release, perhaps as a feedback mechanism to reduce angiotensin production [102].

Nonetheless, the importance of these protective mechanisms for different disease conditions remains to be fully established because their roles vary under pathological conditions, turning a protective into a detrimental mechanism. For example, the AT<sub>2</sub> receptors, commonly regarded as part of the protective arm of the RAAS, can mediate vasoconstriction under conditions of excess ROS production [103]. Similarly, in systemic and pulmonary hypertension the ET<sub>B</sub> receptors were found to be up-regulated in the VSMCs of tunica media, where they can play a pathogenic role [104]. Recent studies have also shown that ET<sub>B</sub> receptors mediate tubulo-interstitial fibrosis and its underlying mechanisms, as discussed below, thus further aggravating kidney damage (Figure 4)[95]. Studies also suggest that eNOS, the enzyme responsible for NO formation, can be stimulated by AT<sub>1</sub> receptor activation, but this effect is probably short-lived. Moreover, a predominant down-regulation of eNOS mediated by the AT<sub>1</sub> receptor has also been reported [105].

## **7. Renal fibrosis in CKD: role of endothelial factors and oxidative stress**

Renal fibrosis, the final common outcome of practically all renal diseases causing CKD, including hypertensive nephro-angiosclerosis [106], entails a progressive loss of nephrons and their replacement by extracellular matrix ultimately leading to ESRD [106]. Fundamental in this process is EMT which entails the loss of epithelial markers by tubular cells and their acquisition of mesenchymal features, alongside loss of cell contacts, degradation of cell adhesion molecules, onset of migration properties, and finally their transformation into fibroblasts, which synthesize collagen and other extracellular matrix proteins [107]. First described in embryo development and cancer, EMT occurs in the kidney and involves transformation not only of tubular cells but also of podocytes into myofibroblasts [108].

ET-1 was found to induce loss of synaptopodin, a podocyte marker, alongside acquisition of the mesenchymal marker  $\alpha$ -smooth muscle actin in cultured mouse podocytes [108]. The selective ET<sub>A</sub>

antagonist sitaxentan prevented these changes [108], thus suggesting a role of this receptor subtype in glomerular EMT. However, more recent work in a transgenic rat model of Ang II-dependent hypertension and in human renal tubular cells, demonstrated a fundamental role of ET-1, acting via ET<sub>B</sub> receptors [95]: EMT was prevented *in vivo* by the mixed ET<sub>A</sub>/ET<sub>B</sub> receptor antagonist bosentan and *in vitro* by the selective ET<sub>B</sub> receptor antagonist BQ-788. Figure 5 summarizes the series of events leading to hypertensive nephron-angiosclerosis via EMT and ET<sub>B</sub> receptor.

A high level of oxidative stress can also participate in this process: the serum levels of the potent antioxidant ascorbic acid are decreased in CKD patients, likely because of malnutrition and hemodialysis [109,110]. Moreover, serum total antioxidant power is also blunted, supporting the view that high oxidative stress can contribute to blunting NO bioactivity, the main opponent of ET-1, in CKD patients. In keeping with this contention chronic administration of green tea was shown to restore endothelium vasodilation through ROS scavenging and to protect from hypertension and kidney damage in a rat model of Ang II infusion [111]. Moreover, green tea extracts decreased left ventricular mass and p22phox, a marker of oxidative stress, in mononuclear cells of CKD patients despite no decrease in BP [112].

### **8. Other endothelial factors in renal vascular remodeling**

Vascular remodeling and endothelial dysfunction are hallmarks of patients with ESRD. In such patients arterial remodeling is related inversely to forearm reactive hyperemia and to serum concentrations of markers of endothelial dysfunction [113], suggesting that the latter contributes to vascular changes in ESRD patients [113]. In hypertension, renal endothelial cell dysfunction is characterized by a decreased release of vasodilatory mediators, such as NO, prostacyclin, and EDHF, and/or an increase in vasoconstrictive mediators, such as ET-1, Ang II, and thromboxane A<sub>2</sub>, as discussed above [19]. This may affect matrix metalloproteinases and their inhibitors resulting in changes of the extracellular matrix composition, leading to renal vascular remodeling [19]. Therapeutic interventions can modulate the synthesis and release of both endothelium-derived relaxing and contracting factors, thus influencing the vascular remodeling process [114].

Environmental risk factors, such as high salt intake and vascular inflammation further promote endothelial

dysfunction in the kidney [115,116], causing increased expression of adhesion molecules, activation of immune cells, cytokine production, and increased oxidative stress [115–117]. Infiltration of immune cells in various organs such as blood vessels, kidney, and perivascular adipose tissue is an important component of the inflammatory process leading to CV damage and hypertension [117]. Evidence has accumulated on the participation of T lymphocytes in hypertension, particularly through effects on the kidney [117]. Once activated, Th1 cells may contribute to BP elevation by affecting the kidney and vascular remodeling of blood vessels directly via the effects of the cytokines produced [117]. By contrast, T-regulatory cells might protect from BP elevation by acting on similar targets [117]. T-regulatory cells and Th1 lymphocyte subtypes also have also opposite effects on endothelial function [117], and on microvascular remodeling [118]. An imbalance of T-cell subsets was observed in Ang II-infused hypertensive rats with kidney injury [119]. Finally, other possible factors linking endothelial factors and vascular morphology include endothelial progenitor cells, which are involved in vascular remodeling and repair and are regarded as a novel marker of vessel wall injury in patients with CKD [120].

## **9. Conclusions**

Compelling evidence indicates that the endothelium plays a fundamental role in preserving vascular health in practically all organs and the kidney is no exception to this rule. Given the key roles of the glomerular and tubular microvasculature in maintaining renal function, preserving and restoring endothelial function and preventing endothelial dysfunction seem to be fundamental for preserving GFR and preventing CKD. The novel knowledge generated on the biology of the endothelium and its derived factors has made substantial contributions to understanding the mechanisms of kidney damage in cardiovascular and metabolic diseases. In the companion manuscript (Part II) we specifically examine endothelial dysfunction in diabetes, preeclampsia, kidney transplantation and how the improving the treatment and prevention of kidney disease,

### **Funding sources:**

GPR and TMS were supported by grants from the Ministry of Health (RF2011-02352318) and from the University of Padova (DOR1625891/16; DOR1670784/16; BIRD163255/16); MB was supported by the



Swiss National Science Foundation (grants 108258 and 122504); AHJD and AHvdM were supported by a grant from the foundation Lijf en Leven; ND was supported by British Heart Foundation Intermediate Clinical Research Fellowship (FS/13/30/29994); DJW was supported by the British Heart Foundation, Kidney Research UK and the Wellcome Trust.

**Financial disclosures and competing interest statement**

MB serves as a consultant to AbbVie, Inc. The other Authors have no financial disclosures and competing interest statement to declare.

## References

- 1 Lim SS, Vos T, Flaxman AD, Danaei G, Shibuya K, Adair-Rohani H, *et al.* A comparative risk assessment of burden of disease and injury attributable to 67 risk factors and risk factor clusters in 21 regions, 1990-2010: A systematic analysis for the Global Burden of Disease Study 2010. *Lancet* 2012; 380:2224–2260.
- 2 Levin A, Tonelli M, Bonventre J, Coresh J, Donner JA, Fogo AB, *et al.* Global kidney health 2017 and beyond: A roadmap for closing gaps in care, research, and policy. *Lancet* Published Online First: 20 April 2017. doi:10.1016/S0140-6736(17)30788-2
- 3 Wanner C, Amann K, Shoji T. The heart and vascular system in dialysis. *Lancet* 2016; 388:276–284.
- 4 Wilkinson IB, McEniery CM. Arterial stiffness, endothelial function and novel pharmacological approaches. *Clin Exp Pharmacol Physiol* 2004; 31:795–799.
- 5 Wilkinson IB, Cockcroft JR, McEniery CM. Aortic stiffness as a cardiovascular risk predictor. *BMJ* 2015; :h3764.
- 6 Tonelli M, Muntner P, Lloyd A, Manns BJ, Klarenbach S, Pannu N, *et al.* Risk of coronary events in people with chronic kidney disease compared with those with diabetes: a population-level cohort study. *Lancet* 2012; 380:807–814.
- 7 Navar LG. The role of the kidneys in hypertension. *J Clin Hypertens* 2005; 7:542–9.
- 8 Jr MAG, Garcia-Cardena G. Endothelial Cell Dysfunction and the Pathobiology of Atherosclerosis. *Circ Res* 2016; 118:620–636.
- 9 Furchgott RF, Zawadzki J V. The obligatory role of endothelial cells in the relaxation of arterial smooth muscle by acetylcholine. *Nature* 1980; 288:373–376.
- 10 Ignarro LJ, Buga GM, Wood KS, Byrns RE, Chaudhuri G. Endothelium-derived relaxing factor produced and released from artery and vein is nitric oxide. *Proc Natl Acad Sci U S A* 1987; 84:9265–9269.
- 11 Barton M. The discovery of endothelium-dependent contraction: the legacy of Paul M. Vanhoutte. *Pharmacol Res* 2011; 63:455–462.
- 12 Hickey KA, Rubanyi G, Paul RJ, Highsmith RF. Characterization of a coronary vasoconstrictor produced by cultured endothelial cells. *Am J Physiol* 1985; 248:C550-C556.
- 13 Yanagisawa M, Kurihara H, Kimura S, Tomobe Y, Kobayashi M, Mitsui Y, *et al.* A novel potent vasoconstrictor peptide produced by vascular endothelial cells. *Nature* 1988; 332:411–415.
- 14 Flammer AJ, Anderson T, Celermajer DS, Creager MA, Deanfield J, Ganz P, *et al.* The assessment of endothelial function: from research into clinical practice. *Circulation* 2012; 126:753–767.
- 15 Tang EH, Vanhoutte PM. Endothelial dysfunction: a strategic target in the treatment of hypertension? *Pflugers Arch* 2010; 459:995–1004.
- 16 Feletou M, Kohler R, Vanhoutte PM. Nitric oxide: orchestrator of endothelium-dependent responses. *Ann Med* 2012; 44:694–716.
- 17 Teerlink T, Luo Z, Palm F, Wilcox CS. Cellular ADMA: regulation and action. *Pharmacol Res* 2009; 60:448–460.

- 18 Schlaich MP, Schmitt D, Ott C, Schmidt BM, Schmieder RE. Basal nitric oxide synthase activity is a major determinant of glomerular haemodynamics in humans. *J Hypertens* 2008; 26:110–116.
- 19 Ponnuchamy B, Khalil RA. Cellular mediators of renal vascular dysfunction in hypertension. *Am J Physiol Integr Comp Physiol* 2009; 296:R1001-R1018.
- 20 Luo R, Zhang W, Zhao C, Zhang Y, Wu H, Jin J, *et al.* Elevated Endothelial Hypoxia-Inducible Factor-1alpha Contributes to Glomerular Injury and Promotes Hypertensive Chronic Kidney Disease. *Hypertension* 2015; 66:75–84.
- 21 Rajagopalan S, Meng XP, Ramasamy S, Harrison DG, Galis ZS. Reactive oxygen species produced by macrophage-derived foam cells regulate the activity of vascular matrix metalloproteinases in vitro. Implications for atherosclerotic plaque stability. *J Clin Invest* 1996; 98:2572–2579.
- 22 Rossi GP, Sacchetto A, Cesari M, Pessina AC. Interactions between endothelin-1 and the renin-angiotensin-aldosterone system. *Cardiovasc Res* 1999; 43:300–307.
- 23 Kitamura K, Tanaka T, Kato J, Ogawa T, Eto T, Tanaka K. Immunoreactive endothelin in rat kidney inner medulla: marked decrease in spontaneously hypertensive rats. *Biochem Biophys Res Commun* 1989; 162:38–44.
- 24 Bourque SL, Davidge ST, Adams MA. The interaction between endothelin-1 and nitric oxide in the vasculature: new perspectives. *Am J Physiol Integr Comp Physiol* 2011; 300:R1288-R1295.
- 25 Kelland NF, Kuc RE, McLean DL, Azfer A, Bagnall AJ, Gray GA, *et al.* Endothelial cell-specific ETB receptor knockout: autoradiographic and histological characterisation and crucial role in the clearance of endothelin-1. *Can J Physiol Pharmacol* 2010; 88:644–651.
- 26 Gerstung M, Roth T, Dienes H-P, Licht C, Fries JWU. Endothelin-1 induces NF-kappaB via two independent pathways in human renal tubular epithelial cells. *Am J Nephrol* 2007; 27:294–300.
- 27 Lenoir O, Milon M, Virsolvy A, Hénique C, Schmitt A, Massé J-M, *et al.* Direct action of endothelin-1 on podocytes promotes diabetic glomerulosclerosis. *J Am Soc Nephrol* 2014; 25:1050–1062.
- 28 Saleh MA, Boesen EI, Pollock JS, Savin VJ, Pollock DM. Endothelin-1 increases glomerular permeability and inflammation independent of blood pressure in the rat. *Hypertension* 2010; 56:942–949.
- 29 Hatakeyama H, Miyamori I, Fujita T, Takeda Y, Takeda R, Yamamoto H. Vascular aldosterone. Biosynthesis and a link to angiotensin II-induced hypertrophy of vascular smooth muscle cells. *J Biol Chem* 1994; 269:24316–24320.
- 30 Takeda Y, Miyamori I, Yoneda T, Hatakeyama H, Inaba S, Furukawa K, *et al.* Regulation of aldosterone synthase in human vascular endothelial cells by angiotensin II and adrenocorticotropin. *J Clin Endocrinol Metab* 1996; 81:2797–2800.
- 31 Ong GS, Young MJ. Mineralocorticoid regulation of cell function: the role of rapid signalling and gene transcription pathways. *J Mol Endocrinol* 2017; 58:R33–R57.
- 32 Davel AP, Anwar IJ, Jaffe IZ. The endothelial mineralocorticoid receptor: mediator of the switch from vascular health to disease. *Curr Opin Nephrol Hypertens* 2017; 26:97–104.
- 33 Nishikawa T, Suematsu S, Saito J, Soyama A, Ito H, Kino T, *et al.* Human renal mesangial cells produce aldosterone in response to low-density lipoprotein (LDL). *J Steroid Biochem*

- Mol Biol* 2005; 96:309–316.
- 34 White PC. Aldosterone: direct effects on and production by the heart. *J Clin Endocrinol Metab* 2003; 88:2376–2383.
- 35 Slight SH, Ganjam VK, Gomez-Sanchez CE, Zhou MY, Weber KT. High affinity NAD(+)-dependent 11 beta-hydroxysteroid dehydrogenase in the human heart. *J Mol Cell Cardiol* 1996; 28:781–787.
- 36 Wendler A, Albrecht C, Wehling M. Nongenomic actions of aldosterone and progesterone revisited. *Steroids* 2012; 77:1002–1006.
- 37 Barton M, Meyer MR. Nicolaus Copernicus and the rapid vascular responses to aldosterone. *Trends Endocrinol Metab* 2015; 26:396–398.
- 38 Romagni P, Rossi F, Guerrini L, Quirini C, Santiemma V. Aldosterone induces contraction of the resistance arteries in man. *Atherosclerosis* 2003; 166:345–349.
- 39 Arima S, Kohagura K, Xu HL, Sugawara A, Abe T, Satoh F, *et al.* Nongenomic vascular action of aldosterone in the glomerular microcirculation. *J Am Soc Nephrol* 2003; 14:2255–2263.
- 40 Liu SL, Schmuck S, Chorazczyzewski JZ, Gros R, Feldman RD. Aldosterone regulates vascular reactivity: short-term effects mediated by phosphatidylinositol 3-kinase-dependent nitric oxide synthase activation. *Circulation* 2003; 108:2400–2406.
- 41 Schmidt BM, Sammer U, Fleischmann I, Schlaich M, Delles C, Schmieler RE. Rapid nongenomic effects of aldosterone on the renal vasculature in humans. *Hypertension* 2006; 47:650–655.
- 42 Rigracciolo DC, Scarpelli A, Lappano R, Pisano A, Santolla MF, Avino S, *et al.* GPER is involved in the stimulatory effects of aldosterone in breast cancer cells and breast tumor-derived endothelial cells. *Oncotarget* 2016; 7:94–111.
- 43 Hall JE, Granger JP, Smith MJ, Premen AJ. Role of renal hemodynamics and arterial pressure in aldosterone “escape”. *Hypertension* 1984; 6:1183–1192.
- 44 Iwakura Y, Morimoto R, Kudo M, Ono Y, Takase K, Seiji K, *et al.* Predictors of decreasing glomerular filtration rate and prevalence of chronic kidney disease after treatment of primary aldosteronism: renal outcome of 213 cases. *J Clin Endocrinol Metab* 2014; 99:1593–1598.
- 45 Oberleithner H. Two barriers for sodium in vascular endothelium? *Ann Med* 2012; 44 Suppl 1:S143-S148.
- 46 Oberleithner H, Ludwig T, Riethmuller C, Hillebrand U, Albermann L, Schafer C, *et al.* Human endothelium: target for aldosterone. *Hypertension* 2004; 43:952–956.
- 47 Kusche-Vihrog K, Jeggle P, Oberleithner H. The role of ENaC in vascular endothelium. *Pflugers Arch* 2014; 466:851–859.
- 48 Korte S, Strater AS, Druppel V, Oberleithner H, Jeggle P, Grossmann C, *et al.* Feedforward activation of endothelial ENaC by high sodium. *FASEB J* 2014; 28:4015–4025.
- 49 Paar M, Pavenstädt H, Kusche-Vihrog K, Druppel V, Oberleithner H, Kliche K. Endothelial sodium channels trigger endothelial salt sensitivity with aging. *Hypertension* 2014; 64:391–396.
- 50 Mueller KB, Bender SB, Hong K, Yang Y, Aronovitz M, Jaisser F, *et al.* Endothelial mineralocorticoid receptors differentially contribute to coronary and mesenteric vascular

- function without modulating blood pressure. *Hypertension* 2015; 66:988–997.
- 51 Amador CA, Bertocchio J-P, Andre-Gregoire G, Placier S, Duong Van Huyen J-P, El Moghrabi S, *et al.* Deletion of mineralocorticoid receptors in smooth muscle cells blunts renal vascular resistance following acute cyclosporine administration. *Kidney Int* 2016; 89:354–362.
- 52 Barrera-Chimal J, Prince S, Fadel F, El Moghrabi S, Warnock DG, Kolkhof P, *et al.* Sulfenic Acid Modification of Endothelin B Receptor is Responsible for the Benefit of a Nonsteroidal Mineralocorticoid Receptor Antagonist in Renal Ischemia. *J Am Soc Nephrol* 2016; 27:398–404.
- 53 Park JB, Schiffrin EL. ET(A) receptor antagonist prevents blood pressure elevation and vascular remodeling in aldosterone-infused rats. *Hypertension* 2001; 37:1444–1449.
- 54 Briet M, Barhoumi T, Mian MOR, Coelho SC, Ouerd S, Rautureau Y, *et al.* Aldosterone-induced vascular remodeling and endothelial dysfunction require functional angiotensin type 1a receptors. *Hypertension* 2016; 67:897–905.
- 55 Kasal DA, Barhoumi T, Li MW, Yamamoto N, Zdanovich E, Rehman A, *et al.* T regulatory lymphocytes prevent aldosterone-induced vascular injury. *Hypertension* 2012; 59:324–330.
- 56 Rossi GP, Bernini G, Desideri G, Fabris B, Ferri C, Giacchetti G, *et al.* Renal damage in primary aldosteronism: results of the PAPY Study. *Hypertension* 2006; 48:232–238.
- 57 Sechi LA, Novello M, Lapenna R, Baroselli S, Nadalini E, Colussi GL, *et al.* Long-term renal outcomes in patients with primary aldosteronism. *Jama* 2006; 295:2638–2645.
- 58 Haynes WG, Webb DJ. Contribution of endogenous generation of endothelin-1 to basal vascular tone. *Lancet* 1994; 344:852–854.
- 59 Brunner H, Cockcroft JR, Deanfield J, Donald A, Ferrannini E, Halcox J, *et al.* Endothelial function and dysfunction. Part II: Association with cardiovascular risk factors and diseases. A statement by the Working Group on Endothelins and Endothelial Factors of the European Society of Hypertension. *J Hypertens* 2005; 23:233–246.
- 60 Seccia TM, Maniero C, Belloni AS, Guidolin D, Pothén P, Pessina AC, *et al.* Role of angiotensin II, endothelin-1 and L-type calcium channel in the development of glomerular, tubulointerstitial and perivascular fibrosis. *J Hypertens* 2008; 26:2022–2029.
- 61 Schiffrin EL. Vascular endothelin in hypertension. *Vascul Pharmacol* 2005; 43:19–29.
- 62 Kohan DE, Inscho EW, Wesson D, Pollock DM. Physiology of endothelin and the kidney. *Compr Physiol* 2011; 1:883–919.
- 63 Briet M, Boutouyrie P, Laurent S, London GM. Arterial stiffness and pulse pressure in CKD and ESRD. *Kidney Int* 2012; 82:388–400.
- 64 Fortier C, Mac-Way F, Desmeules S, Marquis K, De Serres SA, Lebel M, *et al.* Aortic-brachial stiffness mismatch and mortality in dialysis population. *Hypertension* 2015; 65:378–384.
- 65 Vuurmans TJJ, Boer P, Koomans HA. Effects of endothelin-1 and endothelin-1 receptor blockade on cardiac output, aortic pressure, and pulse wave velocity in humans. *Hypertension* 2003; 41:1253–1258.
- 66 d’Uscio L V, Barton M, Shaw S, Moreau P, Luscher TF. Structure and function of small arteries in salt-induced hypertension: effects of chronic endothelin-subtype-A-receptor blockade. *Hypertension* 1997; 30:905–911.

- 67 Barton M, d'Uscio L V, Shaw S, Meyer P, Moreau P, Lüscher TF. ET(A) receptor blockade prevents increased tissue endothelin-1, vascular hypertrophy, and endothelial dysfunction in salt-sensitive hypertension. *Hypertension* 1998; 31:499–504.
- 68 Barton M, Vos I, Shaw S, Boer P, D'Uscio L V, Grone HJ, *et al.* Dysfunctional renal nitric oxide synthase as a determinant of salt-sensitive hypertension: mechanisms of renal artery endothelial dysfunction and role of endothelin for vascular hypertrophy and Glomerulosclerosis. *J Am Soc Nephrol* 2000; 11:835–845.
- 69 Davenport AP, Hyndman KA, Dhaun N, Southan C, Kohan DE, Pollock JS, *et al.* Endothelin. *Pharmacol Rev* 2016; 68:357–418.
- 70 Dhaun N, Lilitkarntakul P, Macintyre IM, Muilwijk E, Johnston NR, Kluth DC, *et al.* Urinary endothelin-1 in chronic kidney disease and as a marker of disease activity in lupus nephritis. *Am J Physiol Physiol* 2009; 296:F1477-F1483.
- 71 Dhaun N, Macintyre IM, Melville V, Lilitkarntakul P, Johnston NR, Goddard J, *et al.* Blood pressure-independent reduction in proteinuria and arterial stiffness after acute endothelin-a receptor antagonism in chronic kidney disease. *Hypertension* 2009; 54:113–119.
- 72 Goligorsky MS. Pathogenesis of endothelial cell dysfunction in chronic kidney disease: a retrospective and what the future may hold. *Kidney Res Clin Pract* 2015; 34:76–82.
- 73 Dhaun N, MacIntyre IM, Kerr D, Melville V, Johnston NR, Haughie S, *et al.* Selective endothelin-A receptor antagonism reduces proteinuria, blood pressure, and arterial stiffness in chronic proteinuric kidney disease. *Hypertension* 2011; 57:772–779.
- 74 Brenner BM, Cooper ME, de Zeeuw D, Keane WF, Mitch WE, Parving HH, *et al.* Effects of losartan on renal and cardiovascular outcomes in patients with type 2 diabetes and nephropathy. *N Engl J Med* 2001; 345:861–869.
- 75 Lewis EJ, Hunsicker LG, Clarke WR, Berl T, Pohl MA, Lewis JB, *et al.* Renoprotective effect of the angiotensin-receptor antagonist irbesartan in patients with nephropathy due to type 2 diabetes. *N Engl J Med* 2001; 345:851–860.
- 76 Parving HH, Lehnert H, Bröchner-Mortensen J, Gomis R, Andersen S, Arner P, *et al.* The effect of irbesartan on the development of diabetic nephropathy in patients with type 2 diabetes. *N Engl J Med* 2001; 345:870–878.
- 77 Weber MA, Black H, Bakris G, Krum H, Linas S, Weiss R, *et al.* A selective endothelin-receptor antagonist to reduce blood pressure in patients with treatment-resistant hypertension: a randomised, double-blind, placebo-controlled trial. *Lancet* 2009; 374:1423–1431.
- 78 Goddard J, Johnston NR, Hand MF, Cumming AD, Rabelink TJ, Rankin AJ, *et al.* Endothelin-A receptor antagonism reduces blood pressure and increases renal blood flow in hypertensive patients with chronic renal failure: a comparison of selective and combined endothelin receptor blockade. *Circulation* 2004; 109:1186–1193.
- 79 Vercauteren M, Trensz F, Pasquali A, Cattaneo C, Strasser DS, Hess P, *et al.* Endothelin ETA Receptor Blockade, by Activating ETB Receptors, Increases Vascular Permeability and Induces Exaggerated Fluid Retention. *J Pharmacol Exp Ther* 2017; 361:322–333.
- 80 Colombo PC, Ganda A, Lin J, Onat D, Harxhi A, Iyasere JE, *et al.* Inflammatory activation: cardiac, renal, and cardio-renal interactions in patients with the cardiorenal syndrome. *Heart Fail Rev* 2012; 17:177–190.
- 81 Reitsma S, Slaaf DW, Vink H, van Zandvoort MAMJ, oude Egbrink MGA. The endothelial glycocalyx: composition, functions, and visualization. *Pflugers Arch* 2007; 454:345–359.

- 82 Dane MJC, van den Berg BM, Avramut MC, Faas FGA, van der Vlag J, Rops ALWMM, *et al.* Glomerular endothelial surface layer acts as a barrier against albumin filtration. *Am J Pathol* 2013; 182:1532–1540.
- 83 Jeansson M, Haraldsson B. Morphological and functional evidence for an important role of the endothelial cell glycocalyx in the glomerular barrier. *Am J Physiol Renal Physiol* 2006; 290:F1111-F1116.
- 84 Gil N, Goldberg R, Neuman T, Garsen M, Zcharia E, Rubinstein AM, *et al.* Heparanase is essential for the development of diabetic nephropathy in mice. *Diabetes* 2012; 61:208–216.
- 85 Harada H, Takahashi M. CD44-dependent intracellular and extracellular catabolism of hyaluronic acid by hyaluronidase-1 and -2. *J Biol Chem* 2007; 282:5597–5607.
- 86 Wang L, Fuster M, Sriramarao P, Esko JD. Endothelial heparan sulfate deficiency impairs L-selectin- and chemokine-mediated neutrophil trafficking during inflammatory responses. *Nat Immunol* 2005; 6:902–910.
- 87 Garsen M, Lenoir O, Rops ALWMM, Dijkman HB, Willemsen B, van Kuppevelt TH, *et al.* Endothelin-1 Induces Proteinuria by Heparanase-Mediated Disruption of the Glomerular Glycocalyx. *J Am Soc Nephrol* 2016; 27:3545–3551.
- 88 van den Hoven MJ, Rops AL, Bakker MA, Aten J, Rutjes N, Roestenberg P, *et al.* Increased expression of heparanase in overt diabetic nephropathy. *Kidney Int* 2006; 70:2100–2108.
- 89 Oberleithner H, Peters W, Kusche-Vihrog K, Korte S, Schillers H, Kliche K, *et al.* Salt overload damages the glycocalyx sodium barrier of vascular endothelium. *Pflugers Arch* 2011; 462:519–528.
- 90 Rossi GP, Seccia TM, Nussdorfer GG. Reciprocal regulation of endothelin-1 and nitric oxide: relevance in the physiology and pathology of the cardiovascular system. *Int Rev Cytol* 2001; 209:241–272.
- 91 Barton M, Shaw S, d’Uscio L V, Moreau P, Luscher TF. Angiotensin II increases vascular and renal endothelin-1 and functional endothelin converting enzyme activity in vivo: role of ETA receptors for endothelin regulation. *Biochem Biophys Res Commun* 1997; 238:861–865.
- 92 Lin YJ, Kwok CF, Juan CC, Hsu YP, Shih KC, Chen CC, *et al.* Angiotensin II enhances endothelin-1-induced vasoconstriction through upregulating endothelin type A receptor. *Biochem Biophys Res Commun* 2014; 451:263–269.
- 93 Kawaguchi H, Sawa H, Yasuda H. Effect of endothelin on angiotensin converting enzyme activity in cultured pulmonary artery endothelial cells. *J Hypertens* 1991; 9:171–174.
- 94 Rossi GP, Ganzaroli C, Cesari M, Maresca A, Plebani M, Nussdorfer GG, *et al.* Endothelin receptor blockade lowers plasma aldosterone levels via different mechanisms in primary aldosteronism and high-to-normal renin hypertension. *Cardiovasc Res* 2003; 57:277–283.
- 95 Seccia TM, Caroccia B, Gioco F, Piazza M, Buccella V, Guidolin D, *et al.* Endothelin-1 drives epithelial-mesenchymal transition in hypertensivenNephroangiosclerosis. *J Am Heart Assoc* 2016; 5:10.1161/JAHA.116.003888.
- 96 Zeisberg EM, Potenta SE, Sugimoto H, Zeisberg M, Kalluri R. Fibroblasts in kidney fibrosis emerge via endothelial-to-mesenchymal transition. *J Am Soc Nephrol* 2008; 19:2282–2287.
- 97 Barton M. Reversal of proteinuric renal disease and the emerging role of endothelin. *Nat Clin Pract* 2008; 4:490–501.

- 98 Barton M. Therapeutic potential of endothelin receptor antagonists for chronic proteinuric renal disease in humans. *Biochim Biophys Acta* 2010; 1802:1203–1213.
- 99 Barton M. Prevention and endothelial therapy of coronary artery disease. *Curr Opin Pharmacol* 2013; 13:226–241.
- 100 Unger T. *The Protective Arm of the Renin Angiotensin System (RAS)*. 1st Edition. Academic Press; 2015.
- 101 van Twist DJ, Kroon AA, de Leeuw PW. Angiotensin-(1-7) as a strategy in the treatment of hypertension? *Curr Opin Nephrol Hypertens* 2014; 23:480–486.
- 102 Kurtz A, Wagner C. Role of nitric oxide in the control of renin secretion. *Am J Physiol* 1998; 275:F849-F862.
- 103 Verdonk K, Danser AH, van Esch JH. Angiotensin II type 2 receptor agonists: where should they be applied? *Expert Opin Investig Drugs* 2012; 21:501–513.
- 104 Iglarz M, Steiner P, Wanner D, Rey M, Hess P, Clozel M. Vascular Effects of Endothelin Receptor Antagonists Depends on Their Selectivity for ETA Versus ETB Receptors and on the Functionality of Endothelial ETB Receptors. *J Cardiovasc Pharmacol* 2015; 66:332–337.
- 105 MacKenzie A. Endothelium-derived vasoactive agents, AT1 receptors and inflammation. *Pharmacol Ther* 2011; 131:187–203.
- 106 Nangaku M. Chronic hypoxia and tubulointerstitial injury: a final common pathway to end-stage renal failure. *J Am Soc Nephrol* 2006; 17:17–25.
- 107 Iwano M, Plieth D, Danoff TM, Xue C, Okada H, Neilson EG. Evidence that fibroblasts derive from epithelium during tissue fibrosis. *J Clin Invest* 2002; 110:341–350.
- 108 Buelli S, Rosano L, Gagliardini E, Corna D, Longaretti L, Pezzotta A, *et al*. Beta-Arrestin-1 Drives Endothelin-1-Mediated Podocyte Activation and Sustains Renal Injury. *J Am Soc Nephrol* 2014; 25:523–533.
- 109 Takahashi N, Morimoto S, Okigaki M, Seo M, Someya K, Morita T, *et al*. Decreased plasma level of vitamin C in chronic kidney disease: comparison between diabetic and non-diabetic patients. *Nephrol Dial Transplant* 2011; 26:1252–1257.
- 110 Locatelli F, Canaud B, Eckardt K-U, Stenvinkel P, Wanner C, Zoccali C. Oxidative stress in end-stage renal disease: an emerging threat to patient outcome. *Nephrol Dial Transplant* 2003; 18:1272–1280.
- 111 Antonello M, Montemurro D, Bolognesi M, Di Pascoli M, Piva A, Grego F, *et al*. Prevention of hypertension, cardiovascular damage and endothelial dysfunction with green tea extracts. *Am J Hypertens* 2007; 20:1321–1328.
- 112 Calo LA, Vertolli U, Davis PA, Maso LD, Pagnin E, Ravarotto V, *et al*. Molecular biology based assessment of green tea effects on oxidative stress and cardiac remodelling in dialysis patients. *Clin Nutr* 2014; 33:437–442.
- 113 Pannier B, Guerin AP, Marchais SJ, Metivier F, Safar ME, London GM. Postischemic vasodilation, endothelial activation, and cardiovascular remodeling in end-stage renal disease. *Kidney Int* 2000; 57:1091–1099.
- 114 Raij L. Mechanisms of vascular injury: the emerging role of the endothelium. *J Am Soc Nephrol* 1991; 2:S2-S8.
- 115 Montezano AC, Touyz RM. Molecular mechanisms of hypertension--reactive oxygen



- species and antioxidants: a basic science update for the clinician. *Can J Cardiol* 2012; 28:288–295.
- 116 Sinha N, Dabla PK. Oxidative stress and antioxidants in hypertension—a current review. *Curr Hypertens Rev* 2015; 11:132–142.
- 117 Ciuceis C De, Rossini C, Boria E La, Porteri E, Petroboni B, Gavazzi A, *et al.* Immune mechanisms in hypertension. *High Blood Press Cardiovasc Prev* 2014; 21:227–234.
- 118 Ciuceis C De, Rossini C, Airo P, Scarsi M, Tincani A, Tiberio GA, *et al.* Relationship Between Different Subpopulations of Circulating CD4+ T-lymphocytes and Microvascular Structural Alterations in Humans. *Am J Hypertens* 2017; 30:51–60.
- 119 Shao J, Nangaku M, Miyata T, Inagi R, Yamada K, Kurokawa K, *et al.* Imbalance of T-cell subsets in angiotensin II-infused hypertensive rats with kidney injury. *Hypertension* 2003; 42:31–38.
- 120 Rabelink TJ, de Boer HC, van Zonneveld AJ. Endothelial activation and circulating markers of endothelial activation in kidney disease. *Nat Rev* 2010; 6:404–414.

## Legends to the Figures

**Figure 1.** Endothelium-derived factors inducing relaxation / growth inhibition and contraction / cell proliferation of vascular smooth muscle cells (VSMCs). Vasodilating factors include nitric oxide (NO), PGI<sub>2</sub> and endothelium derived hyperpolarization (EDH), whereas contracting factors include endothelin-1 (ET-1) and endothelium-derived contracting factors (EDCF), including thromboxane A<sub>2</sub> and prostaglandin H<sub>2</sub>. Shear stress, acetylcholine and bradykinin activate endothelial nitric oxide synthase (eNOS), which generates the soluble gas NO that, after diffusing through the cell membranes of endothelial and VSMCs, binds the soluble guanylate cyclase (sGC). This latter synthesizes cyclic guanosine monophosphate (cGMP) from guanosine-5'-triphosphate (GTP), thereby inducing VSMC relaxation. In contrast, relaxation triggered by EDHF is mostly mediated by activation of K<sup>+</sup> channels and blunting of Ca<sup>2+</sup> channels activity, which cause cell hyperpolarization.

ET-1 is generated from big ET-1 via two endothelin converting enzyme (ECE) isoforms, ECE-1 and ECE-2. In VSMC ET-1 exerts contracting and growth-promoting effects primarily via ET<sub>A</sub> (and in some vascular beds also via ET<sub>B</sub> receptors), whereas, when it binds ET<sub>B</sub> receptors in endothelial cells, activates eNOS leading to NO production, finally inducing relaxation. TXA<sub>2</sub> and Ang II cause VSMCs contraction and proliferation via TP and AT<sub>1</sub> receptors, respectively.

Under physiological condition, a balance between relaxation and contraction allows maintenance of vascular tone. Excess production of Ang II and cytokines, or release of reactive oxygen species (ROS) during inflammation and hypoxia, favor production of ET-1 and hypoxia-induced factor (HIF) along a decrease of NO, thereby causing an unbalanced vasoconstriction. Excess mechanical stress, as well as cardiovascular (CV) risk factors, as aging, smoking, hypercholesterolemia, diabetes mellitus, and hyperhomocysteinemia, also favor production of ROS, particularly superoxide anion (°O<sub>2</sub><sup>-</sup>), which by reacting with NO at a diffusion limited rate ( $6.7 \times 10^9 \times \text{sec}^{-1}$ ) to form the stable peroxynitrite (ONOO<sup>-</sup>), thereby inactivating NO. ADMA also decreases NO bioavailability and activate metalloproteases (MMPs)

that, in turn, induce ONOO<sup>-</sup> production in mononuclear cells, finally amplifying inflammation and leading microcirculatory dysfunction and plaque destabilization.

**Figure 2.** Schematic representation of the actions and interactions of ET-1 (*blue*) between glomerular capillary basement membrane (GBM, *grey*), glomerular endothelial cells (GEC, *yellow*), glomerular podocytes (*green/yellowish*), and the slit diaphragm (*red*). Shown are mechanisms (1-7) which implicate endothelial-cell derived ET-1 in podocyte and glomerular injury. ET-1 is released from cells on both sides of the GBM, namely glomerular endothelial cells (GEC) and podocytes. ET-1 interacts with different cellular components of the glomerular capillary: ET-1 released from GEC interacts with the GBM (1), with the slit diaphragm (2), or with the podocyte (3). ET-1 release and signaling may also occur in the reverse direction. Accordingly, ET-1 released from podocytes may interact with the GBM and vice versa (4). Within the podocyte, ET-1 activates endothelin ET<sub>A</sub> receptors (ET<sub>A</sub>-R) and promotes glomerular cell injury and sclerosis through MAPKs p38 and p44/p42 pathways (5); moreover, ET-1 stimulates growth promoter and cyclin-dependent kinase-inhibitor p21<sup>waf/cip1</sup>, and pro-inflammatory NF-kappa B (6). ET-1 also causes F-actin cytoskeleton disruption (7) and thus slit diaphragm dysfunction (*green*) involving activation of the Rho-kinase and PI<sub>3</sub>-kinase pathways. Figure reproduced with permission from Barton M. Therapeutic potential of endothelin receptor antagonists for chronic proteinuric renal disease in humans. *BBA Molecular Basis of Disease* 2010.

**Figure 3.** Effects of the renin-angiotensin aldosterone system (RAAS) and the endothelin-1 (ET-1) system in the kidney. Under physiological conditions Angiotensin II (Ang II) maintains glomerular filtration rate by modulating the efferent arteriole tone, and regulates blood volume by stimulating water and Na<sup>+</sup> absorption in the distal and collecting tubules, both directly and indirectly via aldosterone production. Pathophysiological conditions as aging, hyperglycemia, hypoxia and inflammation, characterized by release of reactive oxygen species (ROS) and cytokines, cause excess Ang II and ET-1 synthesis. In addition, Ang II stimulates ET-1 synthesis. This translates into constriction of both afferent and efferent arterioles with reduced glomerular filtration rate (GFR), and also into reduction of NO<sup>-</sup> bioavailability that causes renin release from juxtaglomerular cells, finally leading to amplification of the RAAS activity.

**Figure 4.** Relationship between the renin angiotensin aldosterone system (RAAS) and the endothelin-1 (ET-1) system in the glomerulus. Under physiological conditions Angiotensin II (Ang II), via AT1 receptors, regulates the glomerular capillary tone, podocyte function and mesangial cell contraction. Pathophysiological conditions characterized by excess release of reactive oxygen species (ROS) and pro-inflammatory cytokines cause excess Ang II and ET-1 synthesis. Both excess Ang II and ET-1 induce, via AT1 and ET<sub>A</sub> receptors respectively, 1) endothelial damage and podocyte injury, which both cause proteinuria, 2) proliferation of the mesangial cells and extracellular matrix production, 3) epithelial to mesenchymal transition finally leading to glomerular sclerosis and fibrosis.

**Figure 5.** Effects of the renin angiotensin aldosterone system (RAAS) and the endothelin-1 (ET-1) system in the tubulo-interstitial compartment. Under physiological conditions both Angiotensin II (Ang II) and endothelin-1 (ET-1) maintain the vascular tone: AT1, ET<sub>A</sub> and ET<sub>B</sub> receptor subtypes located at the vascular smooth muscle cells (VSMCs) mediate vasoconstriction, whereas ET<sub>B</sub> receptor subtype located at the endothelial cells, by increasing NO<sup>•</sup> bioavailability, mediates vasodilatation. ET<sub>B</sub> receptor also exerts a crucial role by regulating water excretion at the tubular level. When Ang II is abnormally produced, as under conditions characterized by excess mechanical or oxidative stress (e.g. diabetes mellitus, high blood pressure, hypercholesterolemia), AT1 receptors in the VSMCs favor vasoconstriction and vascular remodeling. Excess Ang II also stimulates ET-1 production that, via ET<sub>A</sub> and ET<sub>B</sub> located at the VSMCs, potentiates vasoconstriction, and, via ET<sub>B</sub> receptor subtype, triggers epithelial to mesenchymal transition (EMT), transforming the tubular cells into myofibroblasts that produce collagens, finally leading to tubulo-interstitial fibrosis.

Figure 1

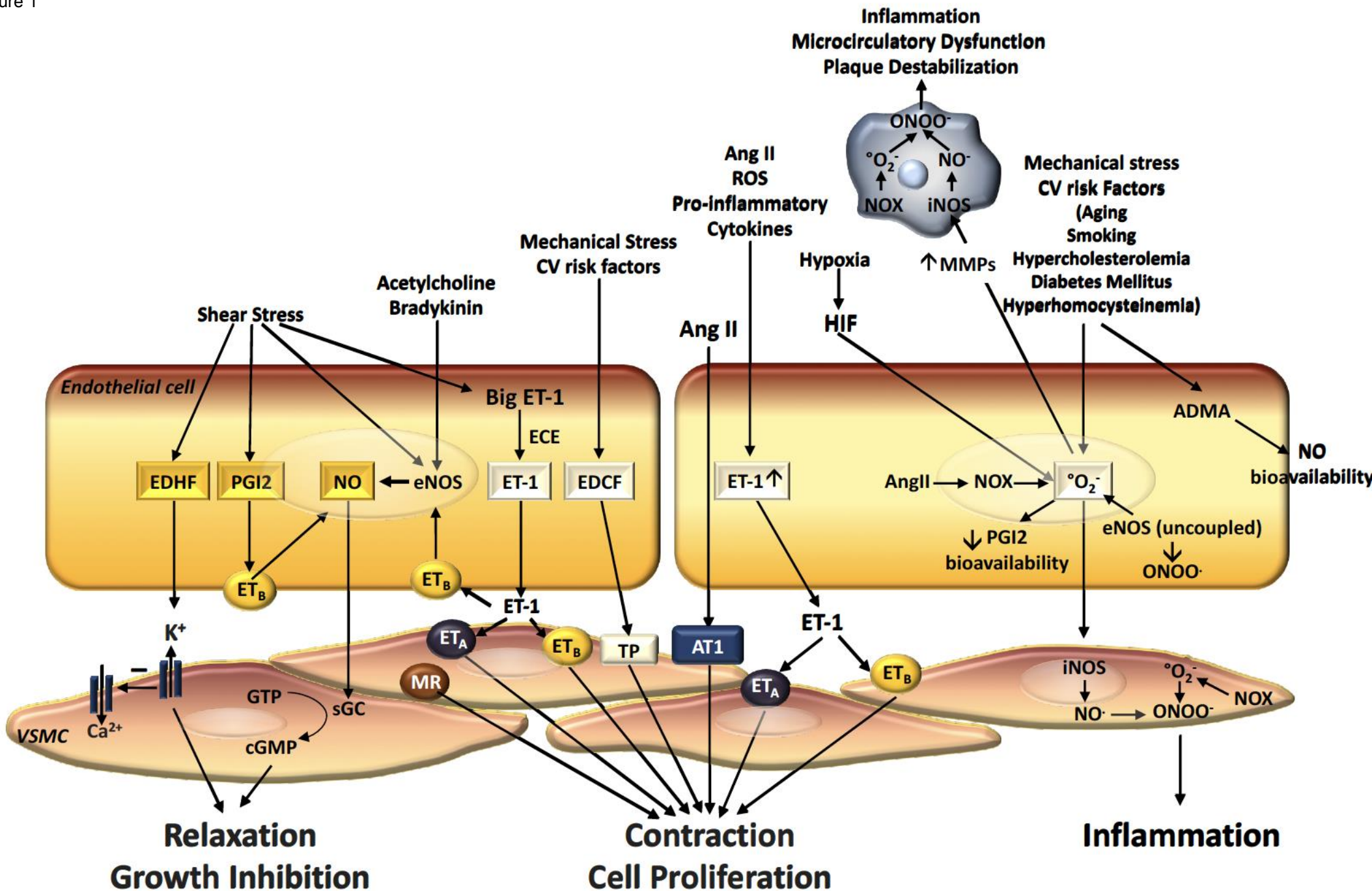

Fig. 1

Figure 2

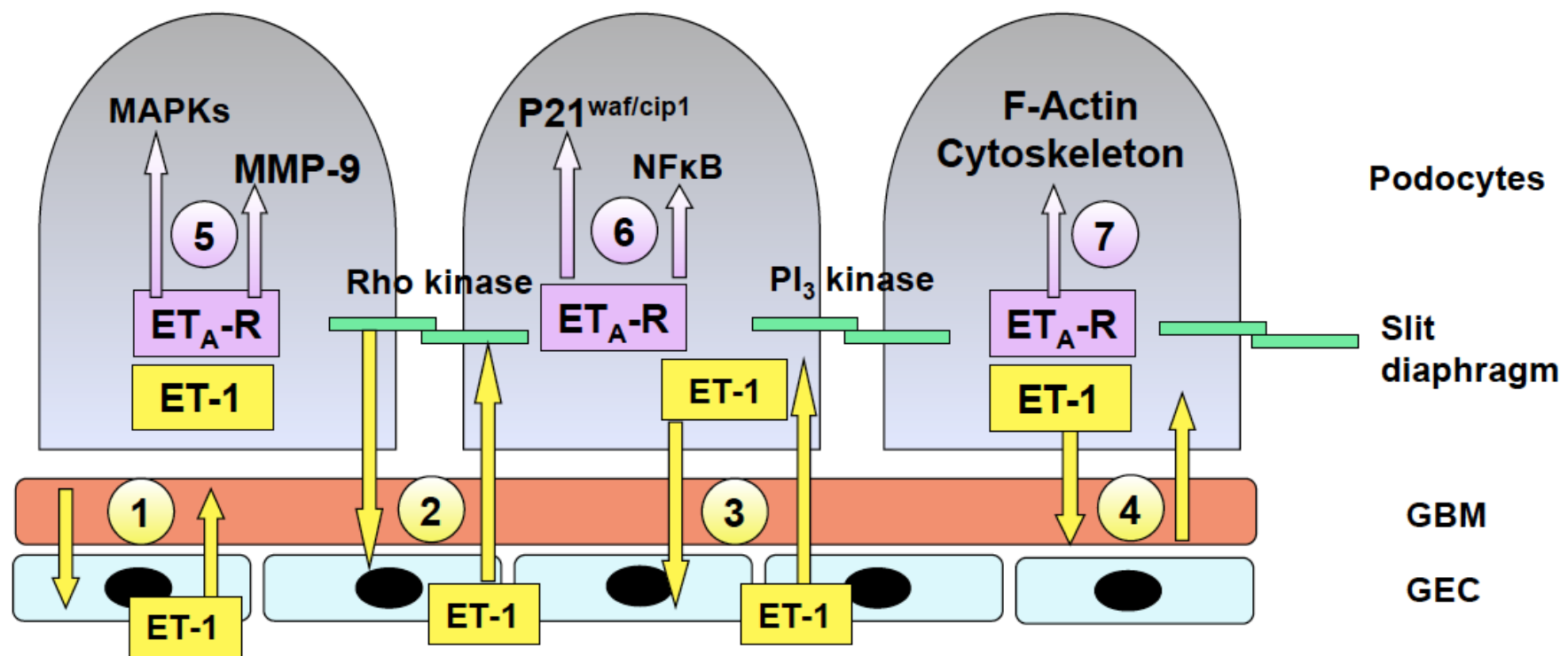

Fig. 2

Figure 3

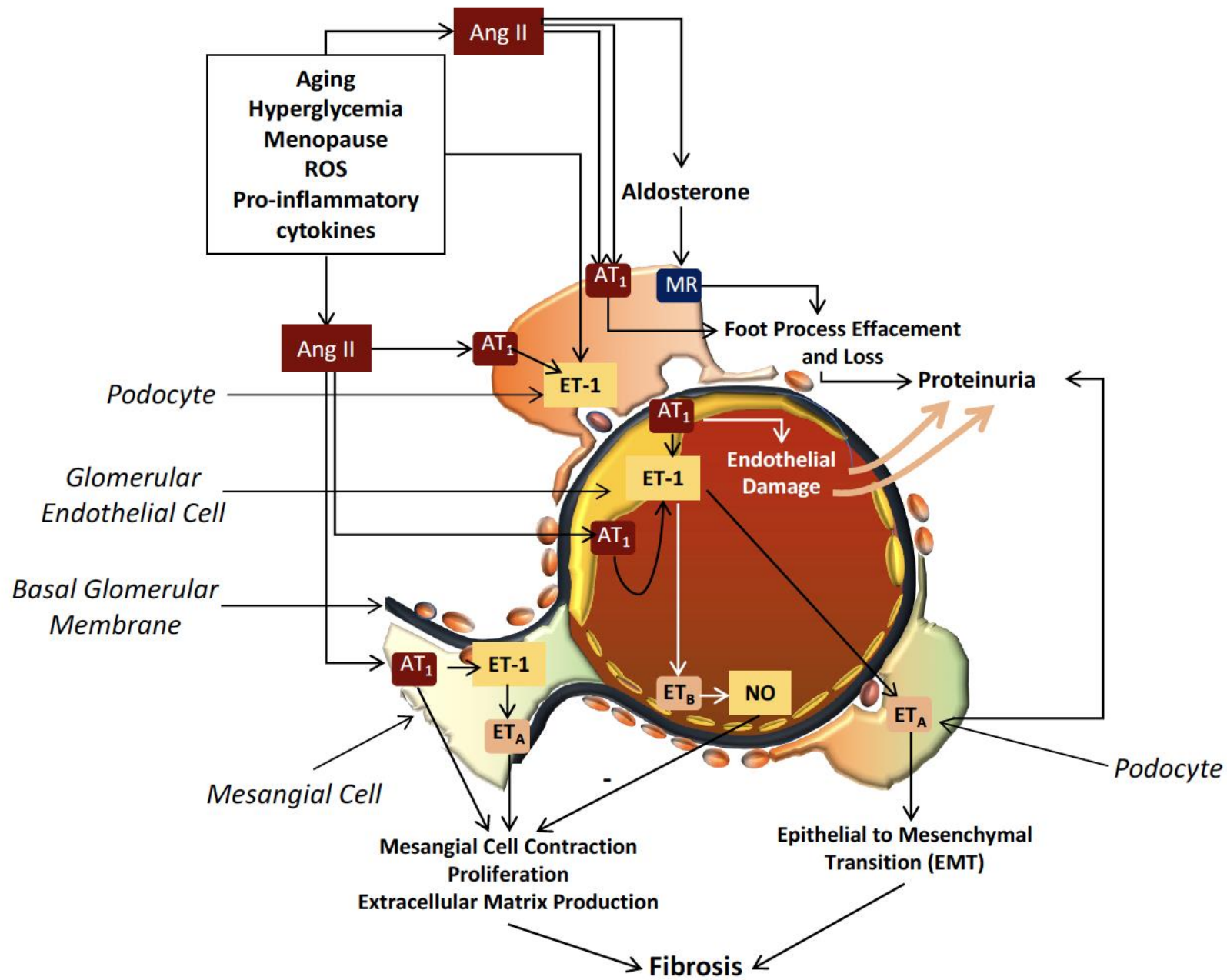

Fig. 3



Figure 4

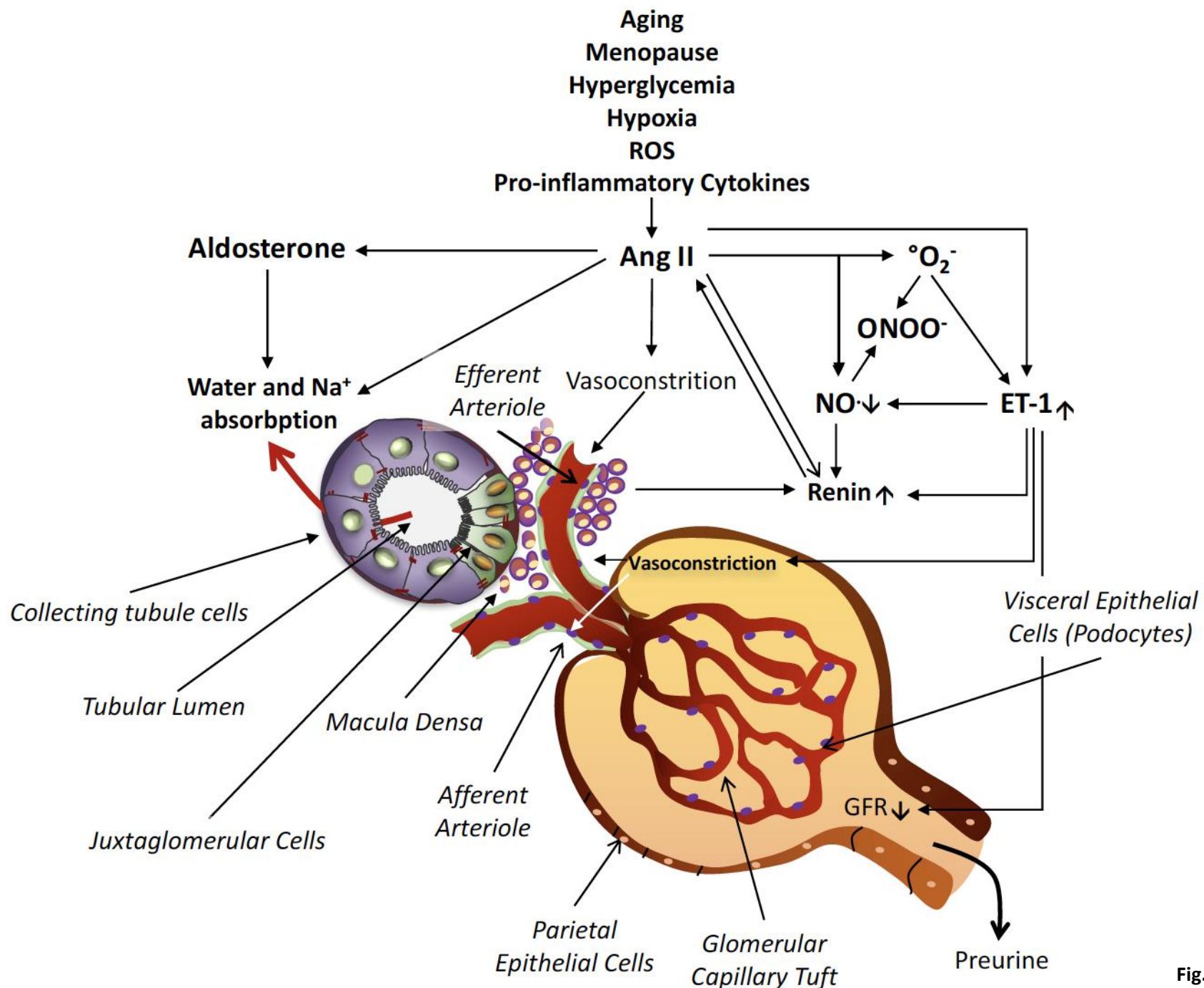
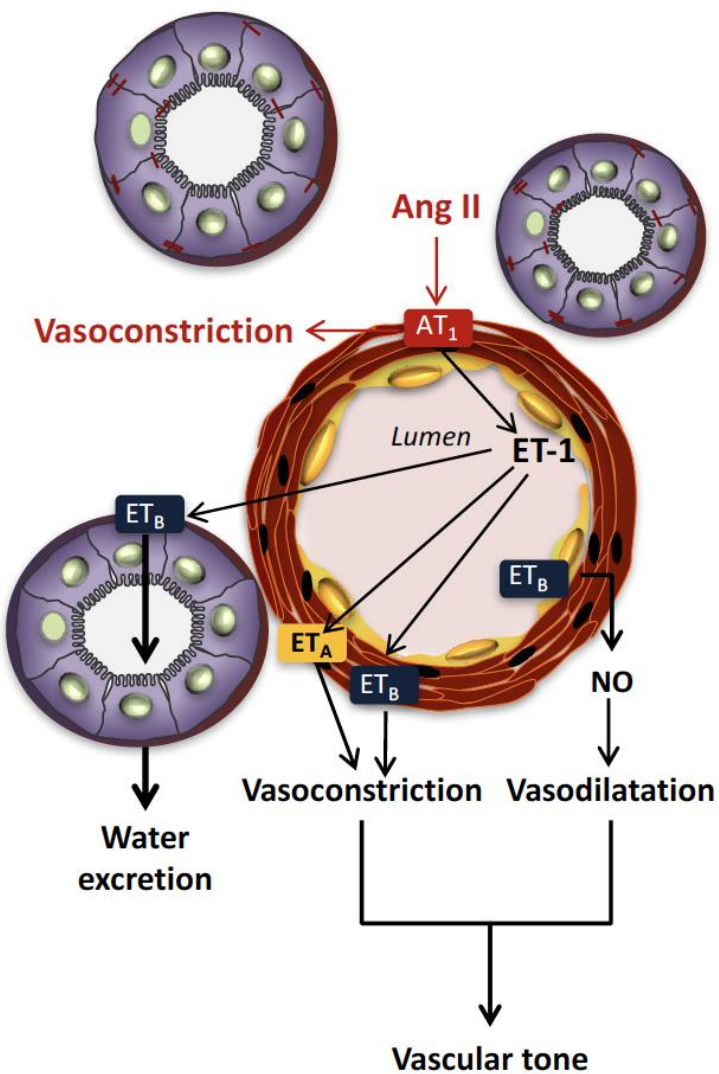

Fig. 4



Figure 5

## Physiology



## Pathophysiology

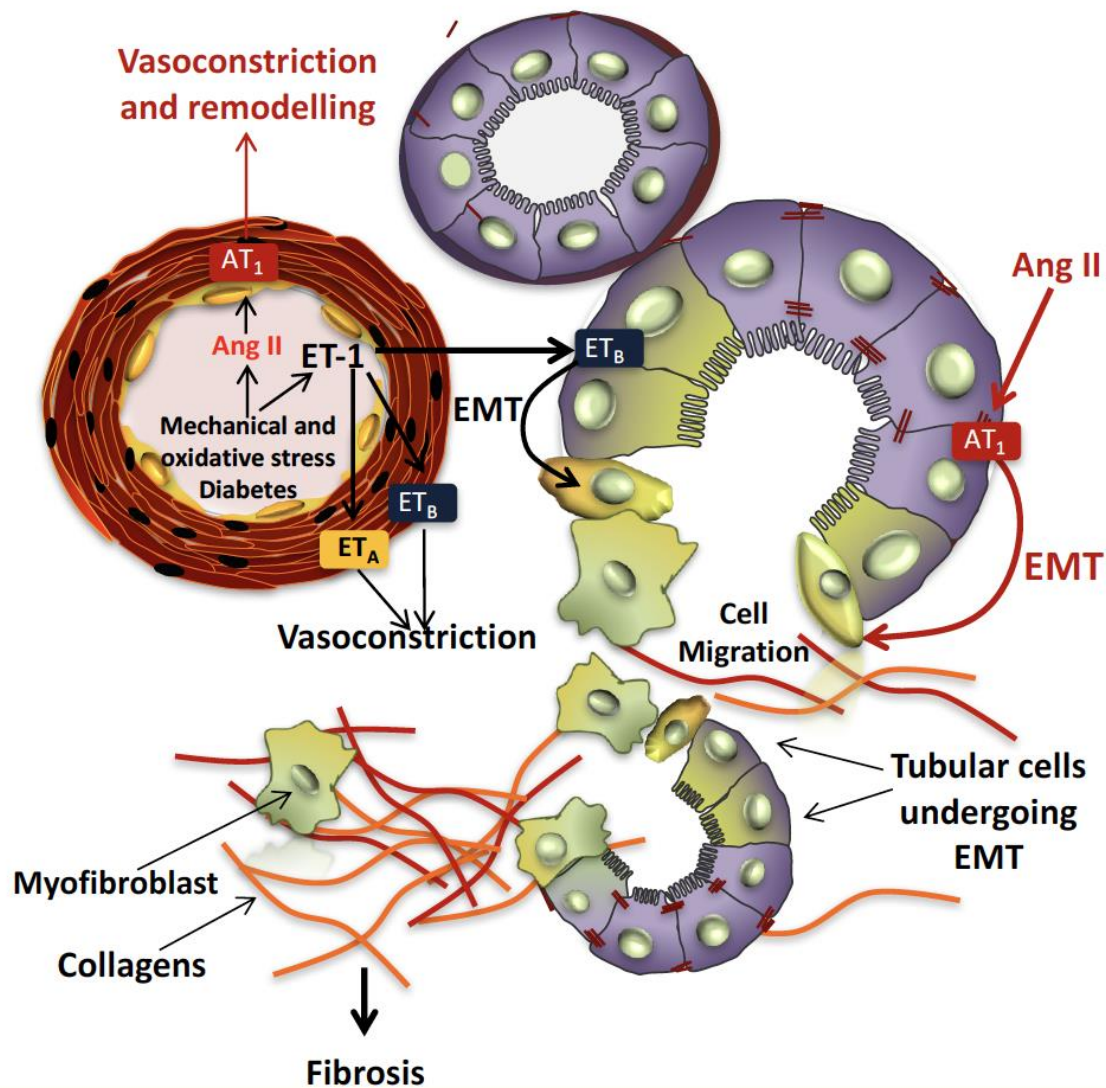

Fig. 5



Click here to access/download

**Supplemental Data File (.doc, .tif, pdf, etc.)**

Suppl Table 1 MeSH terms.docx

