



A paradigm shift in mathematical physics, Part 2: A new local realism explains Bell test & other experiments

Jeffrey H. Boyd

Retired

57 Woods Road, Bethany, CT 06524, USA

jeffreyhboyd@gmail.com

ABSTRACT

An earlier article in this journal introduced a renegade theory called the Theory of Elementary Waves (TEW). Whereas quantum mathematics (QM) is a science of observables, TEW is a science of physical nature independent of the observer. They are symmetrical: complement and support each other. That article left three dangling threads that this article addresses: 1. Our claim that TEW is the only local realistic theory that can explain Bell test experiments, 2. Focusing on the medium in which elementary waves move, and 3. Demonstrating that there is zero experimental support for wave particle duality. TEW is neither the hidden variable theory of Einstein, Podolsky and Rosen (EPR), nor the absorber theory of Wheeler and Feynman, nor an offshoot nor variant of quantum theory. It is a new paradigm, discovered by a dissident, Lewis E. Little who, after his PhD in physics, worked alone for decades outside the ivory tower of academic physics searching for and eventually finding a theory that explains quantum experiments based on local realism. Thomas Kuhn tells us that fate of new paradigms, unfortunately, is to be rejected as gibberish by leaders of the old paradigm. Plate tectonics was dismissed as absurd during the twentieth century.

Indexing terms/Keywords

Theory of Elementary Waves; TEW, Lewis E Little; local realism; wave particle duality; Bell test experiments; wavefunction collapse; wave function collapse; EPR

Academic Discipline And Sub-Disciplines

Physics, Quantum Physics, Foundations of quantum mechanics

SUBJECT CLASSIFICATION

Library of Congress Classification #'s for Quantum Theory are from QC173.96 to QC174.52

for example: QC173.96 Quantum Mechanics Foundations or QC174.12.Q36 Quantum theory

TYPE (METHOD/APPROACH)

Most mathematicians never heard of the Theory of Elementary Waves (TEW). A previous article in this journal introduced the mathematics of TEW and showed it to be symmetrical with quantum math. That articles left three dangling threads, that this article now addresses: 1. TEW is a new form of local realism that explains Bell test experiments, 2. The medium in which elementary waves move is Lorentz ether rather than Einstein's special relativity, and 3. We claim there is zero empirical evidence supporting wave particle duality. Every aspect of TEW is controversial, including these three assertions. Controversy is the hallmark of a paradigm shift, as is the expectation that a new paradigm will be ignored, or denounced as preposterous and absurd. From the viewpoint of the dominant view of science, new paradigms never make sense. Each paradigm regards the other one as asking and answering the wrong questions, using gobbledygook concepts. They are not however equal. One is the dominant and approved paradigm that controls all the resources (prestige, money, promotions, priority scores, ability to decide which ideas are heard and which are stifled), whereas the other is akin to a persecuted minority.

Council for Innovative Research

Peer Review Research Publishing System

Journal: JOURNAL OF ADVANCES IN MATHEMATICS

Vol .10, No.9

www.cirjam.com , editorjam@gmail.com



1. Introduction

In a previous article in this journal we introduced the Theory of Elementary Waves (TEW), which is a seismological paradigm shift for both classical and quantum physics.[1] Wave particle duality is discarded in favor of more complex relationships between waves and particles. That article explained the math, but left three dangling threads. This article ties those up.

1. We will demonstrate that TEW is a local realistic theory that is consistent with the results of many of the Bell test experiments;
2. Explore what sort of medium the elementary rays move in; and
3. Demonstrate that there is no empirical evidence supporting wave particle duality.

The central agenda of TEW is to portray physical nature in an innovative way, using quantum mathematics as our blueprint or roadmap. Our goal is not simply to use “observables” as the connecting link, but to build an astonishing model of physical nature that reflects the guts and inner workings of quantum notation and wave equations. To pursue this goal we need to scuttle many ideas about how physical nature works, and go back to the drawing board: start over. The previous article started with the QM concept of an amplitude (the square root of a probability), which is a complex vector in Hilbert space. We proposed a physical analog in Euclidean space as the building block from which we constructed a new edifice, one that is symmetrical with QM. The physical analog is called an elementary ray, and in particular the amplitude of an elementary ray. The latter amplitudes form a linear vector Hilbert space, replicate Dirac’s notation and lay the foundations for linear algebra. In a third article in this series we will demonstrate that they are the mirror image of the amplitudes around which Richard Feynman built his theory of Quantum Electro-Dynamics (QED). These physical elementary rays that exist independent of the observer in our world of everyday experience are the central focus of TEW.[2–8]

Neither mathematicians nor physicists know TEW. It did not arise from incremental advances of mainstream science. It was cooked up in the kitchen of a dissident with a PhD in physics: Lewis E. Little, working alone over the course of many decades, searching for and eventually finding a local and realistic explanation of quantum experiments. When it burst into mathematical physics in 1996 it was both unexpected and unwelcome. Efforts to smother it have hitherto been unsuccessful.

TEW sounds absurd and nonsensical to mainstream physicists, and is usually ignored. If it is discussed it is inevitably dismissed in a sentence or two, like a bad joke. Thomas Kuhn warns us that previous seismic paradigm shifts were rejected for exactly those reasons.[9] Had scientists discarded theories that sounded absurd and nonsensical at the time, we would still trust phlogiston as the explanation of combustion, understand nothing about why continents drift relative to one another, and we would continue to live in a Ptolemaic geocentric cosmos. Based on Kuhn’s warning, it is wise to be curious about paradigm shifts that make disturbing assumptions, if and only if the new theory is internally consistent, based on experimental evidence, and solves problems that were previously insoluble. All this is true of TEW.

The brain of a mathematician is usually more accustomed than the brain of an ordinary person, to making radically different assumptions, so as to bring our perception of nature into alignment with mathematics. For example, wave equations work the same no matter which way time goes. Mathematicians are comfortable with the idea of time going backwards. Wheeler and Feynman wrote a famous article about that.[10] TEW proposes that time goes forwards but waves travel backwards relative to particles. This assumption also fits wave equation. **If you are comfortable with the shift from saying it is time, to saying it is waves that go in reverse, then you are comfortable with the basic assumption of TEW.**

That which QM calls “nonlocality,” TEW calls “elementary rays.” The first term is vague; the latter term stimulates an elegant mathematics, as we showed. There is a new notation: \mathbb{R} for an elementary ray and \cdot for a particle. The wave-particle of today’s quantum physics is composed of $\mathbb{R} + \cdot$. Every particle has an elementary ray, but not vice versa. In any volume of space there are a finite number of particles but an infinite number of rays.

According to TEW there is a probabilistic guidance system of elementary rays emanating from detectors (and from everywhere else also) that guides particles to their destination. There is no need for the concept of wavefunction collapse. Probabilistic decisions about which ray to follow backwards are made at the particle source. The probability of a particle being emitted in response to a ray is proportional to the square of the amplitude of that particular ray. Once that decision is made, the particle follows its wave with a probability of one. No further interference has any impact on the particle. The reason there is no need for the idea of wavefunction collapse at the detector, is because that “collapse” already occurred before the particle left the source. It’s like someone deciding which partner to stick with prior to their wedding, rather than years later.

Elementary rays are everywhere in space, traveling in all directions at the speed of light, at all frequencies and polarizations, and in all inertial frames. We never noticed this ocean that we are immersed in, because it conveys no energy, does not disturb conservation of energy, and, on its own, has no way to make a detector “click.” Detectors “click” because it is the nature of particles to follow elementary rays. From the behavior of particles we infer the nature and behavior of rays. Particles carry all the energy and momentum needed to make a detector “click” but are incapable of doing anything without following an elementary ray backwards.



Since elementary rays travel in all directions, each ray has a partner: a coaxial ray of the same amplitude, traveling in exactly the opposite direction at the speed of light. They often have different frequencies. The two of them form a partnership. This is called a bi-ray or bi-flux ($\mathbb{R} \otimes \mathbb{R}$). This is the basis of a local realistic theory that explains many Bell test experiments, as we will show. What makes these countervailing rays coherent is unclear. It could be the particles that do so.

Alternatively, it is possible that the entire concept of entanglement does not reflect anything in nature. If two particles are married because they anticipate sharing a single wavefunction collapse, what happens to that marriage contract if we live in a world in which there is no such thing as wavefunction collapse? Is there any definition of "entanglement" that would survive the demise of the concept of wavefunction collapse? Mathematicians are well aware that artifacts can arise from our models that do not necessarily correspond to anything in the real world. We will assume that someone can come up with a definition of entanglement that does not depend on wavefunction collapse. Indeed, the rudiments of such a definition are contained in this article. We will therefore build a mathematical model that is coherent in a world in which probabilistic decisions are made at the particle source, and therefore there is no need for the concept of wavefunction collapse.

2. Explaining a Bell test experiment

The first of the three loose ends is to demonstrate that TEW is a local realistic theory that can explain many Bell test experiments. All the leading experts and textbooks of physics say this impossible. The official party line is that all forms of local realism have been disproved by the Bell test experiments. The establishment believes that this issue is so clear that anyone who wants to reopen the issue is regarded as an ignorant fool.

2.1 What are the Bell test experiments?

In 1935 Einstein, Podolsky and Rosen (EPR) published a thought experiment: two entangled particles are sent in opposite directions.[10] QM says you can know nothing about a particle until wavefunction collapse at the moment of measurement. EPR says if you test one particle and find its spin is up, you can infer the spin of the other is down, even before testing that particle. They conclude that QM is "incomplete," which is an issue that makes no sense to us today: we don't care whether QM is "complete" or "incomplete." Those words make no sense to us. But those words were once hotly debated between people like Einstein and Bohr. We will refer to the EPR idea as "local realism based on hidden variables." We call it "local" because the variables are inside the particle. Spin is an example. It is called "realistic," because this appears to be how everyday reality works.

Thirty years later (1964) John Bell published a paper that changed history.[11,12] He said that under specialized circumstances the predictions of QM would differ from the EPR predictions. A Bell variable S can be created that is bounded if EPR is true, but not if EPR is false. The two different theories (QM versus EPR) imply a different velocity of information transmission. According to QM two entangled particles are both part of the same wave equation. Therefore if you test one particle, a signal is sent to the other particle instantaneously, no matter what the distance between them. Sometimes physicists say that a particle on the other side of the galaxy can instantaneously affect a change in a particle here. That idea is neither local nor realistic. EPR implies a signal sent from one detector to the other would not exceed the speed of light. So the Bell test experiments can be interpreted as a race for speed.

So, is EPR or QM correct? Many Bell test experiments favored QM. Spinning particles are impractical in the laboratory: hard to handle. The most practical way to test QM versus EPR is by using an entangled pair of photons, and using polarizers to test them. In 1964 Clauser, Horne, Shimony and Holt (CHSH) designed such an experiment. A specialized variable S , was called the Bell parameter, as mentioned above.[14] Boris Cirel'son (or Tsirelson), a mathematician from Leningrad, proved that for EPR $|S| \leq 2$, whereas for QM, the range of S is $\pm 2\sqrt{2}$. [15] Bell's Theorem is that for any local realistic theory, $|S| \leq 2$. In 1982 Aspect, Grangier and Roger built exactly the experiment designed by CHSH, and their data showed that $|S| > 2$. [16]

Thirty years of experiments followed, slowly plugging up all possible loopholes in the Bell test experimental theory, or so it was thought. It is widely believed that these experiments not only prove EPR wrong, but also discredit any possible alternative theory based on local realism.[17] But they used an incorrect definition of "local realism," one that does not apply to TEW.

2.2 Different ways to define "local"

There are two ways to define "local," which lead to different mathematics. It can mean "near A," or it can mean "near A and distant from B."

TEW uses the first definition of "local." It means that cause and effect are in proximate relationship with one another: they are nearby, in the same neighborhood. We define "realism" to mean that something is commonsensical and naturalistic, so that ordinary people would recognize it as the world they live in. Our definition of "local" as meaning "near A" does not mean "distant from B." For example, a field often has a local effect, but is not confined to the neighborhood of the particle being affected. A field can locally affect many particles that are distant from one another.

Using the second definition of "local," Bell and CHSH assumed that "local" means "distant from B." In other words, a variable is geographically confined: restricted to the neighborhood of one particle (A), and banned from the other neighborhood. This odd way of thinking worked OK for testing Einstein's idea, because one particle would not

instantaneously know that the spin of its twin had been tested.

The Bell test experiments were not designed to test the first definition of “local.” According to the Bell way of thinking, TEW would be incorrectly classified as a NON-local theory! Another way of stating it is that TEW lives outside the jurisdiction of Bell’s Theorem.

2.3 A Bell test experiment published in 2008 in Physical Review Letters

We will discuss one of the most recently published Bell test experiments: Salart, Baas, van Houwelingen, et. al.[18] At their headquarters in Geneva, they use spontaneous parametric down-conversion (SPDC) to create a pair of orthogonally polarized photons, of frequency 1573.0 nm and 1567.8 nm respectively. In debates between TEW and QM you will find TEW focusing on the particle source, because that is where all probabilistic decisions are made; whereas you will find QM focusing on the detection equipment, because they believe that is where all probabilistic decisions are made.

The pair of entangled photons created in Geneva travel in opposite directions through two fiber optic cables to two Swiss towns: Satigny and Jussy that are 18 km apart. By tradition the test equipment is called Alice at one end and Bob at the other. The CHSH prototype has Alice rotating a polarizer and then using a photomultiplier to discover whether or not a photon is detected. 18 km away Bob is doing likewise, but he knows nothing about Alice’s angle of rotation. Outcome data are based on the coincidence rate: i.e. how often do Alice and Bob detect a photon simultaneously. In the experiment of Salart et al the polarizers are replaced with Michelson interferometers. The rotation of polarizers is replaced by changing the temperature of the interferometer in Jussy, which changes its phase.

Let d_1 and d_2 be values for the phases in the two interferometers (one in each town). $E(d_1, d_2)$ is the correlation coefficient. The Bell parameter S for this particular experiment is defined:

$$S = |E(d_1, d_2) + E(d_1, d'_2) + E(d'_1, d_2) - E(d'_1, d'_2)| \tag{1}$$

Salart et al demonstrate with their data that $S = \pm 2\sqrt{2}$, which violates the Bell inequality ($|S| \leq 2$) by dozens of standard deviations, and thereby violates Bell’s Theorem (i.e. shows that EPR predictions are wrong). Figure 1 shows the coincidence rate over time (i.e. as the Jussy interferometer cools).

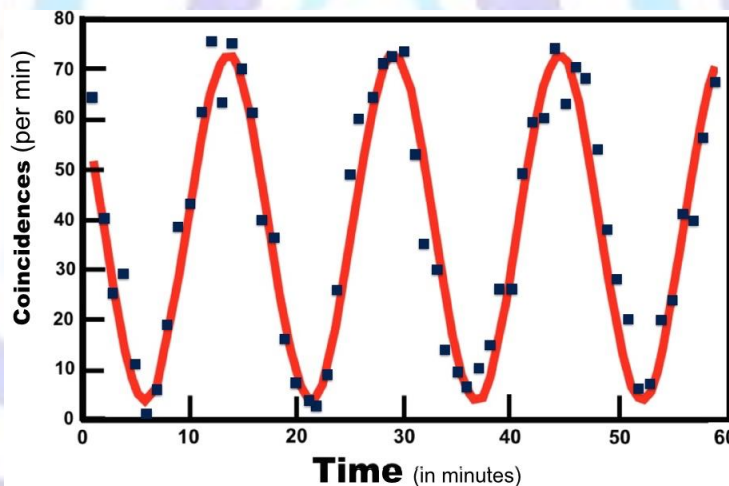

Fig. 1 Data from Salart, Baas, van Houwelingen, et. al. (2008)

According to the CHSH tradition the outcome data should conform to the sinusoidal curve $\sin^2(\theta_2 - \theta_1)$ where θ_1 is the angle of Alice’s polarizer and θ_2 is Bob’s. Since Salart et al used interferometers rather than polarizers, it is unclear where the origin and Y-axis should be in Figure 1. The sinusoidal curve can slide to the left or right depending on the temperature of Bob’s equipment in Jussy. Figure 1 could just as well be a graph of $\cos^2(\theta_2 - \theta_1)$.

The Salart research team faced a problem when they designed their experiment: how to get experimental results published in the physics literature when there have already been thirty years of similar publications about Bell test experiments. Their solution was to design their experiment so that a tiny inertial mass was moved as part of the detection equipment. This allowed them to write an article about “when is wavefunction collapse” finished. Their answer, “When an inertial mass moves,” was a novel idea that allowed them to get their research published in a leading physics journal. However, that issue of moving an inertial mass is irrelevant for our purposes, and we will not mention it again.

2.4 TEW math for this experiment

QM says that two photons are entangled because they are both part of the same wave equation ψ_E where the subscript

“E” means entangled. In TEW that notation becomes more complex: $\psi_E \equiv \Pi + (\mathbb{R}_R \mathbb{R}\hat{U}\mathbb{R}_L) + \Pi$. This notation means that we subdivide the wavefunction ψ_E into several components. There are two independent photons, symbolized by Π . Then there is the bi-ray $(\mathbb{R}_R \mathbb{R}\hat{U}\mathbb{R}_L)$ that the photons are following. Each photon follows both components of the bi-ray. The TEW equivalent of Born’s rule is that the probability of a photon following a bi-ray is the amplitude of it following one ray times the amplitude of it following the other. Since both prongs have the same amplitude, this is the equivalent of Born’s rule: $P = |A|^2$. Using color to make the math easier to visualize we will use red for rays moving to the right and blue for left moving rays. Thus $\mathbb{R}_R \mathbb{R}\hat{U}\mathbb{R}_L$ becomes $\mathbb{R}_R \mathbb{R}\hat{U}\mathbb{R}_L$.

The bi-ray rotates by $\pm \pi/2$ as it passes through an SPDC source (Figure 2). That rotation is built into the equipment. Two photons emerge from the SPDC source in Geneva with orthogonal polarization. Since TEW interprets those photons as following bi-rays, the rays must likewise be orthogonal as they emerge from the source in Geneva. Bi-rays penetrate through the origin: that implies a rotation inside the origin of $+\pi/2$ in one direction and $-\pi/2$ in the other direction.

Let us project the internal structure of the bi-ray onto vertical and horizontal eigenstates: on the left a polarization of V and H will be rotated on the right to become a polarization of H and $-V$. In Figure 2 that $\pm \pi/2$ rotation is symbolized by the diagonal lines inside the yellow rectangle. The yellow rectangle represents the SPDC source, and the 45° lines inside the yellow triangle represent the $\pm \pi/2$ rotation.

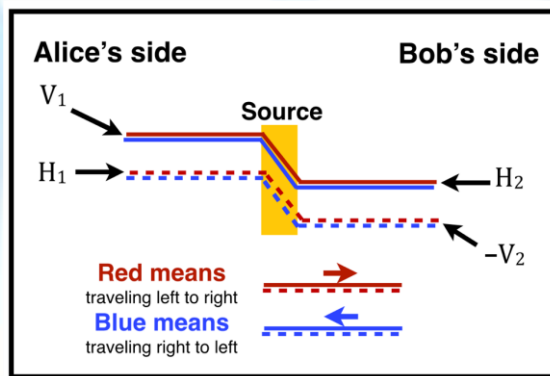

Fig 2 The H & V projections of elementary rays rotate passing through an SPDC source.

The solid and dashed lines are orthogonal to each other. On Alice’s side the orthogonality is V_1 versus H_1 . On Bob’s side the orthogonality is H_2 versus $-V_2$. The diagonal lines crossing the yellow rectangle are symbolic of $\mathbb{R}_R \mathbb{R}\hat{U}\mathbb{R}_L$ rotating by $\pm \pi/2$ as the rays pass through the photon source.

A mono-ray has two eigenstates: V and H. However a bi-ray has four. On the left side of Figure 3 those four eigenstates are labeled A, B, C and D.

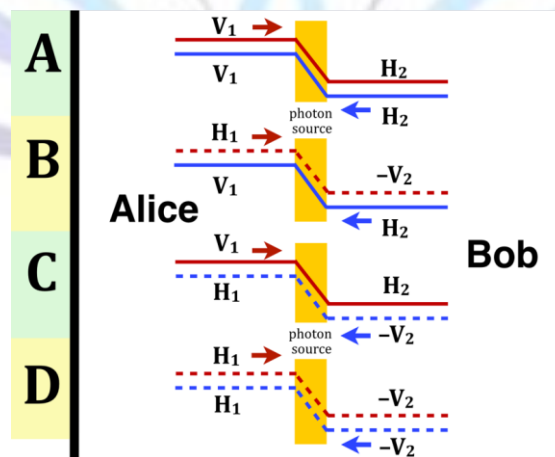

Fig 3 The four eigenstates (A, B, C & D) of the bi-ray $(\mathbb{R}_R \mathbb{R}\hat{U}\mathbb{R}_L)$.

Alice and Bob’s polarizers are turned to random angles θ_1 and θ_2 . We can map those angles onto vertical and horizontal projections using sines and cosines. This mapping is shown by dotted lines in Fig 4.

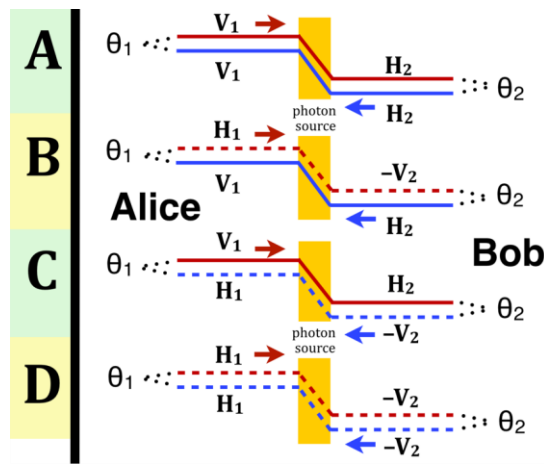

Fig 4 This differs from Figure 3 by adding the polarizer angles θ_1 and θ_2 .

Consider the question, “What is the probability that Alice will see a photon at polarizer angle θ_1 ?” To answer this question we will focus on the left side of Figure 4, ignoring the right side. The probability of Alice seeing a photon will be the sum of her seeing it in one of the four eigenstates. Within each eigenstate the probability will be the amplitude of the photon following one prong of the bi-ray times the amplitude of it following the other prong of that same bi-ray. The magnitude of these components is defined by the cosine or sine mapping θ_1 onto the vertical or horizontal plane. Thus it would be $(\sin \theta_1 \sin \theta_1) + (\cos \theta_1 \sin \theta_1) + (\sin \theta_1 \cos \theta_1) + (\cos \theta_1 \cos \theta_1)$ corresponding to eigenstates A, B, C and D respectively. This trigonometry can be read directly off the left side of Figure 4. We can write exactly the same equation but add color for the direction of the wave involved: **P(Alice sees a photon) = $(\sin \theta_1 \sin \theta_1) + (\cos \theta_1 \sin \theta_1) + (\sin \theta_1 \cos \theta_1) + (\cos \theta_1 \cos \theta_1)$** . As we said, red and blue colors refer to the following elementary rays: $(\hat{R}_R \hat{U} \hat{R}_L)$.

However, that question and answer are irrelevant. The research question does not ask about the probability of Alice alone seeing a photon. The research question asks what is the probability of both Alice AND Bob seeing a photon simultaneously. This is a trickier question.

To answer this question we will break it into four questions: “What is the probability of Alice and Bob simultaneously seeing a photon in eigenstate n ,” where n ranges from 1 to 4. We will use the law of probability that the probability of two things both happening is the probability of one times the probability of the other. Thus if we look at the first eigenstate (the top line of Figure 4), the answer is $(\sin \theta_1 \sin \theta_1) \times (\cos \theta_2 \cos \theta_2)$, where the yellow “X” stands symbolically for the SPDC photon source. The probability of Alice seeing a photon in eigenstate A is on the left of the yellow “X.” The probability of Bob seeing a different photon in eigenstate A is to the right of the yellow “X.” We can write exactly the same equation but add color: **$(\sin \theta_1 \sin \theta_1) \times (\cos \theta_2 \cos \theta_2)$** .

If we add all four eigenstates we get the probability of both Alice & Bob simultaneously seeing a photon:

$$\begin{aligned}
 & (\sin \theta_1 \sin \theta_1) \times (\cos \theta_2 \cos \theta_2) + \\
 & (\cos \theta_1 \sin \theta_1) \times ((\check{\sin} \theta_2) \cos \theta_2) + \\
 & (\sin \theta_1 \cos \theta_1) \times (\cos \theta_2 (\check{\sin} \theta_2)) + \\
 & (\cos \theta_1 \cos \theta_1) \times ((\check{\sin} \theta_2) (\check{\sin} \theta_2))
 \end{aligned} \tag{2}$$

This can be factored:

$$\begin{aligned}
 & = (\sin \theta_1 \cos \theta_2 \check{\cos} \theta_1 \sin \theta_2) \\
 & \times (\sin \theta_1 \cos \theta_2 \check{\sin} \theta_1 \sin \theta_2)
 \end{aligned} \tag{3}$$

and simplified:

$$\begin{aligned}
 & = (\check{\sin} (\theta_2 \check{\theta}_1)) \\
 & \times (\check{\sin} (\theta_2 \check{\theta}_1))
 \end{aligned} \tag{4}$$

which yields the probability that both Alice and Bob will see a photon simultaneously:

$$= \sin^2(\theta_2 \check{\theta}_1). \tag{5}$$

Equation 5 coincides with the predictions of QM and with the data produced by the Salart experiment. Thus we have accomplished that which the experts say is impossible to do.

QED

2.5 Local realism based on hidden variables

Since there is a sinusoidal connection of the data of Alice and Bob, that suggests hidden variables. Bell test experiments proved that those variables are not hidden inside the photons. We propose that they are hidden inside the bi-ray. The bi-ray was present inside the equipment, stretching from Satigny to Geneva to Jussy long before the electricity was turned on. The bi-ray was there while the physicists were partying the previous Saturday night. When a pair of photons was created, it was in response to this bi-ray. This bi-ray is local and realistic, using the first definition of "local": it is "near A and also B." Bell's variable $S = \pm 2\sqrt{2}$.

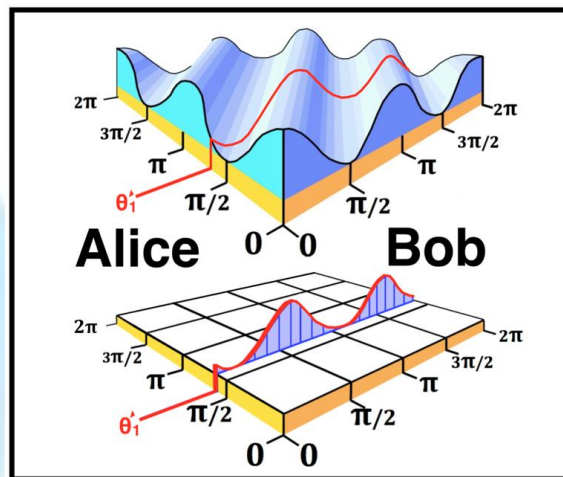

Fig 5 Two equivalent ways to graph the contingency variables carried inside the bi-ray

The top half of Figure 5 is a three dimensional, and the bottom half a two dimensional view of the same thing. If Alice chooses polarizer angle θ_1' then the probability that Bob will see a simultaneous photon if he set his polarizer to angle θ_2 is proportional to the height on the Z axis of the red sinusoidal curve.

Figure 5 shows the nature of the contingency variables carried inside the bi-ray. The probability of Bob seeing a photon simultaneously with Alice when she holds her holds her polarizer at angle θ_1' , if Bob to chooses random polarizer angle θ_2 , is the height of the red line on the Z axis (Figure 5). For example, if Alice holds her polarizer at angle $\theta_1' \cong 0.65 \times \pi$, then Bob probably won't see a simultaneous photon if he sets his polarizer to $0.15 \times \pi$, but probably will see a photon if he sets his polarizer to $0.65 \times \pi$. If Alice changes her angle, then the probabilities for Bob change. That is why we call it "contingency variables."

2.6 Communication faster than instantaneous!

The Salart experiment went to great lengths to control the speed of light as a variable. Alice is in Satigny and Bob is in Jussy that are 18 km apart. It cost a lot of time and money to create that distance, using a lot of fiber optic cable. The reason for the wide separation is to prove that Alice and Bob could not be communicating with each other by any unknown method, unless that communication were faster than the speed of light. As we mentioned, the Bell test experiments are, in part, a race for speed. The wide separation was also required to allow time for an inertial mass to move (an issue discussed earlier).

Because the outcome data are sinusoidal (see Figure 1), and because $S = \pm 2\sqrt{2}$, therefore the researchers conclude that they have disproved EPR and also disproved any other form of local realism, because they think local realism is incompatible with Alice and Bob communicating with each other faster than the speed of light.

John Bell said that communication between Alice and Bob would be instantaneous if QM were true, because the variables in question are internal to the same wavefunction. Therefore if the wavefunction collapses in Satigny when Alice detects a photon, it instantaneously collapses in Jussy, no matter what the distance. This experiment was so designed that it could and did show that Alice and Bob made coordinated measurements faster than light could have travelled between them.

What the Bell test experimenters never considered was that a new form of local realism would emerge, namely TEW, which is faster than instantaneous! How is that possible? The bi-ray inside the Salart equipment carries the contingency variables shown in Figure 5. Those variables were the same last week, this week and next week, nonstop. So TEW won today's race last week! It's like rushing to get into a race, only to discover that the race is rigged and the winner was



determined last week.

Many physicists object that until Alice detects a photon, there is no information to communicate to Bob. This confirms that we are ignorant fools. When Alice sees a photon, that causes wavefunction collapse, which is the “information” that is then transmitted to Bob. Therefore we are talking nonsense when we speak of communication faster than instantaneous. The quantum physicists want to start the stopwatch when there is wavefunction collapse.

Perhaps mathematicians find it easier than physicists to understand what a paradigm shift means. It means TEW describes a world free of wavefunction collapse. Those physicists schooled in the old paradigm experience the new paradigm as gibberish. If we attempt to explain the new paradigm then the old timers will say we moved from gibberish to hogwash, and from hogwash to poppycock and mumbo jumbo.

3. Exploring the medium within which elementary waves travel

We switch now to a different and unrelated topic: Do elementary waves move in a medium? This has nothing to do with Bell test experiments. This is the second of the three topics mentioned at the beginning of this article: three issues left dangling by the preceding article. Almost everyone considers Einstein’s special relativity to be one of the basic truths of nature. This section of the article will discard special relativity.

3.1 Lorentz ether

Franco Selleri (1936-2013) championed local realism and the empirical study of the foundations of physics. He rejected wave particle duality. He published lots of experimental evidence that quantum waves convey zero energy, and are different than particles. Experimental physicists told Selleri they considered his ideas “dangerous,” for if they conducted an experiment to test Selleri’s ideas then their laboratory would lose its prestige in the world of physics. Selleri’s data showed that waves produce interference; particles make the interference pattern visible. He published 350 papers, was author of many books, and trained about fifty graduate students, many of whom are now full professors of physics, mostly in Italy. It never occurred to Selleri that his “quantum waves” might be traveling in the opposite direction as particles. Nevertheless he blazed a trail through the thicket, and TEW follows Selleri’s trail.[19-21]

Many scientists challenged Selleri, saying that they could not accept his idea of quantum waves (divorced from particles) unless there were a medium through which those rays travel. He puzzled over this and proposed an answer.

By swapping Einstein’s special relativity for Lorentz ether (sometimes spelled “aether”), Selleri proposed such a medium. He says the Hans Reichenbach synchronization parameter (epsilon ϵ), which is $\frac{1}{2}$ for special relativity, fits the empirical data better if $\epsilon = 0$. For example, that solves the problem of the Sagnac effect. Data from a Sagnac interferometer, spinning on a turntable, cannot be explained by special relativity. But if we set $\epsilon = 0$ those data can be explained.[22]

Selleri says that Einstein was aware that his rule that light travels at the same speed for all observers was an arbitrary convention, not a law of nature. If $\epsilon = 0$, then the uniform speed of light is sacrificed for absolute simultaneity. Two events that are simultaneous for one observer are simultaneous for all observers. The speed of light is constant in any one inertial frame and is the speed limit. But the speed of light, c , is not the same in all inertial frames. The speed $c = 299,792$ kilometers per second is probably only true in our inertial frame.

Selleri says that quantum waves travel in a medium, namely Lorentz ether at rest. In Lorentz ether the equations for transformation of the X, Y and Z axes from one inertial frame to another are the same as those equations for special relativity. The equation for transformation of time, however, is different: simpler than the corresponding equation of special relativity.

To summarize: if you change the Reichenbach synchronization parameter from $\epsilon = 0.5$ to $\epsilon = 0$, then you shift from special relativity to Lorentz ether at rest; and you shift from a uniform speed of light in all inertial frames to absolute simultaneity in all inertial frames. When you search for a medium within which elementary rays travel, that medium is Lorentz ether at rest. For further details the reader is referred to Selleri’s writings. Selleri was considered an expert on relativity. I am not.

4. Empirical data fail to support wave particle duality

This article ties up three loose ends that were left dangling in a previous article. Bell test experiments were the first loose end. Lorentz ether was the second. The third and final loose end is to demonstrate that there is zero empirical evidence supporting wave particle duality. This allegation contradicts what is taught by the all experts and written in textbooks of physics. Once again TEW proves to be a renegade theory.

4.1 The Davisson Germer experiment

In the 1920’s there was the Davisson Germer experiment.[23-24] They fired electrons of various voltages at a nickel crystal, and detected the intensity and angle of electrons bouncing off. The left side of Figure 6 shows their experimental equipment. To the right of Figure 6 are two graphs showing some of the Davisson Germer data. In the far right there is a conspicuous spur in the intensity of the electrons detected at $\theta = 50^\circ$ and 54 volts. That spur cannot be explained based solely on the behavior of electrons as particles. The spur indicates the presence inside the experiment of waves of $\lambda = 1.67 \text{ \AA}$. Electrons make those waves visible, so the spur indicates that waves and electrons are interacting inside the experiment.

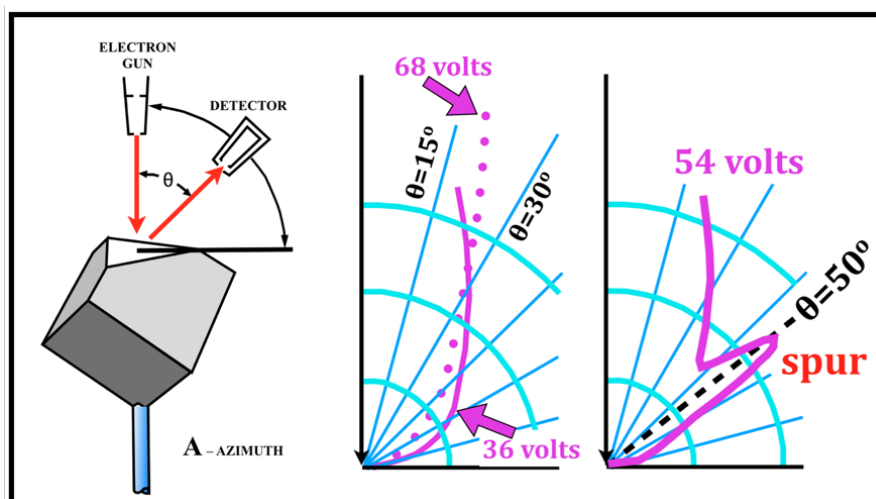

Fig 6 Davisson and Germer fired electrons at a nickel crystal

Left is their equipment, recording electrons coming from the nickel crystal lattice at angle θ . On the right are two graphs of their data. Greater distance from the origin indicates greater intensity (greater voltage) at the detector. The pink curves behave as one would expect from electrons as particles, except for a spur in the data at 54 volts and angle $\theta = 50^\circ$, which indicates waves of $\lambda = 1.67 \text{ \AA}$ refracting through the crystal.

There are four possible ways that waves and electrons could interact inside the Davisson Germer experiment. Wave particle duality is only one of them. A second, favored by Selleri, is that the waves are always present (going in the same direction as the electrons) and they interact. Selleri's proposal differs from wave particle duality because the waves would be present even if the electrons were not, which could be tested empirically by turning down the frequency of electron emission to the point that only one electron at a time was in the experiment. A third possibility is that the wave and particle were traveling in opposite directions when they interacted. A fourth is advanced TEW: the electrons interacted with a bi-ray ($\hat{R}_R \hat{R}_L$).

Of these four, the founders of QM only knew the first. In the 1920's the leaders were on a campaign to find empirical data to support their wave-particle theory, because the Schrödinger and other wave equations appeared to describe particles. Any evidence supporting wave-particle duality would be and was enthusiastically welcome. Davisson and Germer were instantly famous. Davisson was given a Nobel Prize for work he did on electron refraction, laying the foundations for inventions like the electron microscope.

Unfortunately, the data in Figure 6 do not prove wave particle duality.

In summary: Davisson and Germer produced data that indicate that electrons and waves interact inside their experiment. There are four explanations of what that means. No one has proved that wave-particle duality is better than the other three. Until such proof is published there should be a moratorium on claims that they "proved" wave particle duality.

4.2 Wheeler's thought experiment

Wave particle duality research in recent decades focuses on a thought experiment by John Archibald Wheeler.[25] A photon enters a Mach-Zender interferometer and must immediately choose whether to traverse the device along both arms, thereby acting like a wave; or just one arm, thereby acting like a particle. There is delayed choice: during the photon's nanoseconds inside the interferometer a decision is made downstream whether to make the interferometer open or closed. An open interferometer tests the photon as if it were a particle. Closed tests it as a wave.

Wheeler's prediction is that if you test it as a particle it will be a particle, and if as a wave then a wave. This prediction implies that time to goes backwards. Cause and effect are reversed. In other words the photon will correctly guess upon entering the interferometer whether it will later be tested as a particle or wave, even though that decision has not yet been made, and will be made at random at a later time. It would be like going to bed on Monday night wearing either gray or plaid pajamas, and therefore waking up the previous Friday night wearing either gray or plaid pajamas. How would you even know if this happened? In this author's view, science includes only those propositions that can be refuted by empirical data. The proposition about pajamas is not refutable and therefore not science.

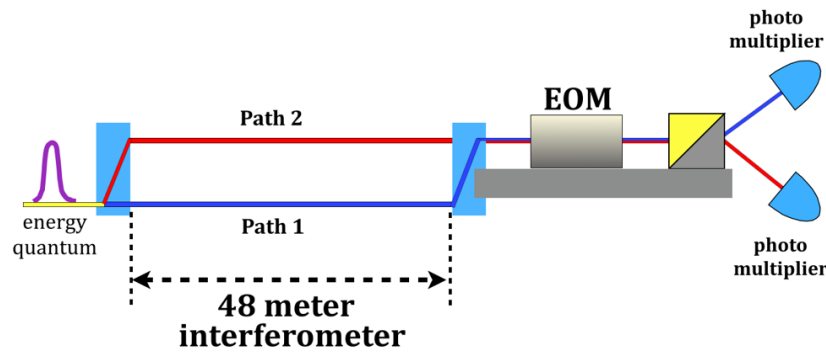

Fig 7 A quantum (left) enters an interferometer & must decide to be a particle or wave.

Jacques, Wu, Grosshans, et. al. built a Mach–Zehnder interferometer 48 meters wide. A single quantum of energy (left) enters a beam splitter (blue). It must commit to traversing the interferometer on one of the two arms orthogonally polarized arms, or traversing both arms simultaneously (particle vs. wave). The two polarized beams are recombined and enter an electro-optical modulator (EOM) that can rapidly rotate or not rotate the beam. Then the beam enters a Wollaston prism and is split into two and recorded. If it was a particle then only one of the detectors will click. If it was a wave then both detectors will click simultaneously.

Jacques, Wu, Grosshans, et. al. (2007) built the interferometer that Wheeler had designed.[26] They made it 48 meters wide in order to delay the photon long enough so they could set their equipment at random to test it as a particle or a wave. Their outcome data said that if you look for a particle you will find a particle, and if you look for a wave you will find a wave, as Wheeler predicted.

There are two diametrically opposite ways to interpret the meaning of this.

1. The researchers wrote: “Our realization of Wheeler’s delayed-choice *gedanken* experiment demonstrates that the behavior of the photon in the interferometer depends on the choice of the observable that is measured, even when that choice is made later in time.”[26] In other words, they affirmed Wheeler’s idea of backwards in time causation. The EOM’s later decision how to test the quantum determined the earlier decision made by the quantum as it entered the front door of the interferometer whether to act like a particle or a wave.
2. Our interpretation is simpler: if you look for a particle you see a particle, and if a wave then you see a wave. Therefore both particles and waves are simultaneously present. There is zero evidence that one turns into the other. If, for example, you take a photo of people and in one photo you see a woman, and in another photo a man, then you do NOT conclude that the women are turning into men and vice versa depending on which lens you use in your camera.

Occam’s razor dictates that we should choose simpler explanations. Our explanation is more parsimonious than the explanation of Wheeler and his followers. Our explanation simply reiterates what the data say: nothing more, nothing less. For the Wheeler and Jacques explanation you have to turn your mind into a pretzel. Therefore this experiment, which is cited as being “proof” that wave particle duality is true, proves rather that particles and waves are not mutually exclusive. Thus it disproves wave particle duality.

4.3 Peruzzo’s 2012 experiment about wave particle morphing

An experiment on wave particle duality was published in *Science* in 2012 by Peruzzo, Shadbolt, Brunner, Popescu and O’Brien.[27] The unavoidable question in the wave particle debate is which direction the waves travel relative to the particles. How do Peruzzo et al deal with that issue? Like everyone else, they ignore it, even though that hypothesis had been published six years earlier by Lewis E. Little. Peruzzo et al gather no data and never mention that problem in their text. Perhaps they had not bothered to read the physics literature?

What does their research focus on? They eliminate delayed choice from the Wheeler experiment, replacing it with “a quantum-controlled beamsplitter, which can be in a superposition of present and absent.” An ancillary photon controls a Hadamard beam splitter, which determines whether the interferometer is open or closed.[30] By putting that ancillary photon into a superposition, they are able to put the entire interferometer into a superposition of being both open and closed at the same time, as shown in this equation:

$$I_{D'} = \frac{1}{2} \cos^2 \alpha + \cos^2 \left(\frac{\varphi}{2} \right) \sin^2 \alpha \tag{6}$$

where $I_{D'}$ is the intensity observed at location D' , φ is the phase, and α is the state of the ancillary photon. The variable α controls whether the interferometer is open $\alpha = 0$ or closed $\alpha = \pi/2$. Because of the superposition, α can take intermediate values between zero and $\pi/2$.

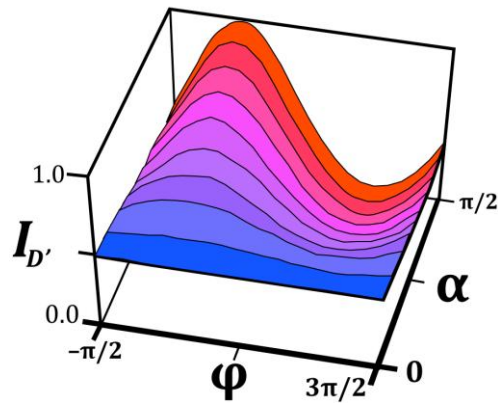

Fig 8 Data from Peruzzo, et.al.

The graph shows intensity I_D on vertical axis, phase ϕ on the X axis, and the state of the ancillary photon α on the Y axis. When $\alpha = 0$ the blue part curve is flat, indicating that the quantum acts like a particle. When $\alpha = \pi/2$ the red curve is sinusoidal, indicating that the quantum acts like a wave. Peruzzo refers to the intermediate colors as “morphing” or “continuous transition between wave and particle.”

Whereas previous experimental designs toggled between the interferometer being open $\alpha = 0$ and closed $\alpha = \pi/2$, the brilliance of the Peruzzo design is that α is a continuous variable, thereby allowing them to test intermediate states, such as the quantum is tested 63 % as a particle and 37 % as a wave. Their outcome data is discussed in the caption to Figure 8 (above).

The conclusion of the Peruzzo study is that wave particle duality is not just a “duality” but is a continuum such that a quantum can exhibit intermediate behavior in which it is a mixture of both. A study by Kaiser et. al. found the same thing.[28]

If you start with a hypothesis that waves travel in the opposite direction, then these data of Peruzzo are of little or no interest. It is not clear how to explain the Peruzzo data, but the data are irrelevant and boring.

In the end we find that empirical studies that allegedly “prove” wave particle duality do no such thing. They never test which way the waves are traveling. TEW offers a more parsimonious explanation of the Jacques experiment. This means that when you add up all the data supporting wave particle duality, the pile of data tilts slightly in the direction of disproving wave particle duality!

4.4 Kaiser’s neutron interferometer experiment

Since none of the experiments allegedly “proving” wave particle duality address the central issue (which direction waves travel relative to particles), we surveyed the published physics literature in search of any other experiment that addresses that question. We found a neutron interferometer experiment that serves the purpose. Helmut Rauch’s team did many experiments in the 1980’s and 1990’s that laid the foundations of neutron interferometry as a science. The article in question, by Kaiser, Clothier, Werner, Rauch and Wölwitsch, reports several of those experiments.[29] One aspect of that complex article is diagrammed in Figure 9.

A neutron beam enters an interferometer where it is split into two beams (ψ_1 and ψ_2) and a device (not shown) immediately induces phase shifts of ψ_1 versus ψ_2 . When the two beams are later recombined and exit the interferometer, a detector downstream finds interference, because of the changing phase difference. Bismuth slows neutron beams. As more and more bismuth is added in the upper ψ_2 pathway that neutron wave packet is delayed in reuniting with ψ_1 and the magnitude of interference decreases. With a large sample of bismuth (i.e. 20 mm) the ψ_2 wave packet arrives at the reunion site after the ψ_1 wave packet has left the back door of the interferometer, and no interference is recorded.

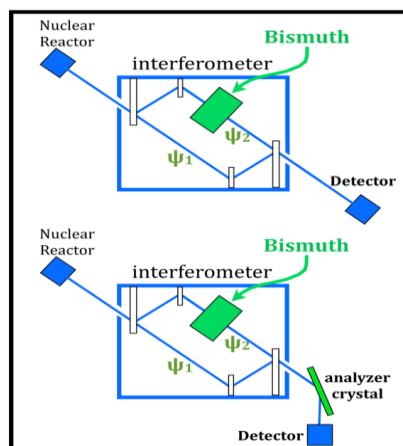

**Fig 9 Neutron interferometer experiment of Kaiser et al.**

The top and bottom diagram differ in only one respect: the absence or presence of an analyzer crystal in front of the detector (lower right). With enough bismuth all interference dies out with the apparatus shown in the top. But when an analyzer crystal is added, robust interference is restored inside the interferometer!

However, when a pressed silicon analyzer crystal is inserted in front of the detector (bottom right of Figure 9) robust interference is restored upstream, inside the interferometer! The researchers say they cannot explain this. They cite Wheeler's smoky dragon: meaning that unexplainable things happen in quantum experiments. But the data are easily explained if waves start at the detector and travel in the reverse direction as the neutrons.

An analyzer crystal increases the coherence length of a wave packet from 86.2 Å to 3450 Å, which is more than enough to penetrate backwards through a full sample of 20 mm bismuth which can delay a wave packet by 435 Å or less. Therefore when an analyzer crystal is inserted, the elementary waves starting at the detector and traveling right to left, experience robust interference despite the bismuth. The elementary ray enters the nuclear reactor, connects with a decaying nucleus, and a neutron follows the ray backwards to the detector. Rays undergo interference; particles make that interference pattern visible: as Selleri said.

In conclusion, there is no empirical evidence that wave particle duality is true. There is evidence that elementary rays travel in the opposite direction as particles.

5. Summary

No matter how the subject is approached, trying to introduce TEW to mathematicians is akin to asking them to jump down Alice's rabbit hole into an alternative reality. There is no getting around it. We can at least cushion the landing by describing how TEW relates to scientific ideas that are widely accepted as solid. In the case of three conventional ideas discussed in this essay, we have, unfortunately upset the apple cart all three times. It is generally considered to be a solid "fact"

1. That the Bell test experiments have proved that all local realism is wrong,
2. That Einstein's special relativity deserves to be the prevailing worldview, and
3. That wave-particle duality is as solidly established as any fact in science.

We have no doubt offended many people by pitching all three "facts" into the trashcan. This is why TEW is so disreputable. We explained our reasoning, but to many readers this will sound like Lewis Carroll explaining the logic of his fanciful novels.

This is the second of three articles introducing TEW to mathematicians. In the first we defined TEW and showed that it is designed to be a partner to QM. TEW deals with physical nature independent of the observer. It uses QM mathematics as a roadmap to help us understand the appearance and behavior of nature. QM deals with observables: it is a science of meter readings. When QM crosses the boundary line, from observables into commenting on nature independent of the observer, it speaks outside its area of expertise. Schrödinger's cat is a warning to us that QM should not do that lest QM make preposterous statements.

The primary focus of TEW is on the relationship between mathematics and physical reality. The issues discussed in these three articles provide a foundation for a new era of exploration by those who are attracted to rebel causes. Some of the ideas we have presented are undoubtedly stupid or false. Einstein said, "A person who never made a mistake never tried anything new." Hopefully these articles contain as many new ideas as mistakes.

A third article, not yet submitted to *Journal of Advances in Mathematics* for editorial consideration, shows that Richard Feynman's discussion of Quantum Electro-Dynamics (QED) is a mirror image of TEW. If we remove from QED the incorrect assumption that amplitudes and particles travel in the same direction, then QED is the same as TEW. However rich and intriguing that observation might be for both TEW and QED, unfortunately the two bodies of scholarship have an unavoidable small conflict: amplitudes (i.e. waves) either travel in the same direction as particles, as Feynman assumes, or in the opposite direction, as TEW assumes. In the next article we will demonstrate that QED is a mirror image of TEW, and we will present three experimental designs for which the two sciences predict different outcomes. Most quantum physicists will be delighted that we set forth the blueprints by which future experiments could torpedo TEW, assuming the experiments provide data supporting QM and discrediting TEW. Most mathematicians will be intrigued with a new paradigm in mathematical physics.

5. Acknowledgment

This article is informed by ideas learned from Lewis E. Little.

6. Bibliography

- [1] J. H. Boyd, A paradigm shift in mathematical physics, Part 1: The Theory of Elementary Rays (TEW), *Journal of Advances in Mathematics* (in press).
- [2] J. H. Boyd, A new variety of local realism explains a Bell test experiment: the Theory of Elementary Waves (TEW) with no hidden variables, *Journal of Advances in Physics* **8**, 2051-58 (Mar 2015)
- [3] J. H. Boyd, The Theory of Elementary Waves eliminates Wave Particle Duality, *Journal of Advances in Physics* **7**, 1916-1922 (Feb 2015).



- [4] J. H. Boyd, Re-thinking Alain Aspect's 1982 Bell test experiment with delayed choice, *Physics Essays* **26** (4) 582-591 (2013).
- [5] J. H. Boyd, Re-thinking a delayed choice quantum eraser experiment: a simple baseball model, *Physics Essays* **26**, 100-109 (March 2013), (doi: 10.4006/0836-1398-26.1.100).
- [6] J. H. Boyd, Rethinking a Wheeler delayed choice gedanken experiment, *Physics Essays* **25**, (3) pp. 390-396, 2012. doi: <http://dx.doi.org/10.4006/0836-1398-25.3.390>
- [7] L. E. Little, *Theory of Elementary Waves*, *Physics Essays* **9** (1), 100-134 (1996).
- [8] L. E. Little, *Theory of Elementary Waves*, (New Classics Library, New York, 2009).
- [9] T. S. Kuhn, *The Structure of Scientific Revolutions*, (Chicago: U. of Chicago Press, 1996).
- [10] J. A. Wheeler and R. P. Feynman, Interaction with the absorber as the mechanism of radiation, *Reviews of Modern Physics* **17**, #2-3, 157-181 (1945).
- [11] A. Einstein, B. Podolsky and N. Rosen, Can quantum-mechanical description of physical reality be considered complete? *Physical Review* **47**, 777-780 (1935).
- [12] J. S. Bell, On the Einstein Podolsky Rosen paradox, *Physics* **1**, 195-200 (1964).
- [13] J. S. Bell, The paradox of Einstein, Podolsky and Rosen: action at a distance in quantum mechanics?, *Speculations in Science and Technology* **10**, # 4, 269-285 (1987).
- [14] J. F. Clauser, M.A. Horne, A. Shimony and R. A. Holt, Proposed experiment to test local hidden-variable theories, *Physical Review Letters* **23**, 880-884 (1969).
- [15] B. S. Cirel'son, Quantum generalizations of Bell's inequality, *Letters in Mathematical Physics* **4**, 93-100 (1980) available online at <http://link.springer.com/article/10.1007/BF00417500#page-1>, (access date June 5, 2015).
- [16] A. Aspect, J. Dalibard, G. Roger, Experimental test of Bell's inequalities using time-varying analyzers, *Physical Review Letters* **49**, 1804-1807 (1982).
- [17] A. Aspect, Bell's inequality test: more ideal than ever. *Nature* **398**, 189-190 (18 March 1999).
- [18] D. Salart, A. Baas, J. A. W. van Houwelingen, N. Gisin, and H. Zbinden, Spacelike separation in a Bell test assuming gravitationally induced collapses, *Physical Review Letters* **100**, 220404-1 to 220404-4 (2008). DOI: 10.1103/PhysRevLett.100.220404
- [19] O. Freire, Oral History Transcript of Interview with Dr. Franco Selleri, Niels Bohr Library and Archives, (June 24-25, 2003) transcribed from an audiotape of two sessions of the interview in Bari.
- [20] F. Selleri, On the direct observability of quantum waves, *Foundations of Physics* **12**, 1087-1112 (1982).
- [21] M. Barone, Obituary: Franco Selleri (2036 - 2013), *CERN Courier*, <http://cerncourier.com/cws/article/cern/56228> (access date: Feb 9, 2015)
- [22] H. Reichenbach, The philosophical significance of the theory of relativity, in Schlipp, P.A. (editor) *Albert Einstein, Philosopher-Scientist: The Library of Living Philosophers Volume VII* (Open Court; 3rd edition (December 30, 1998)), 287-312
- [23] C. J. Davisson and L. Germer, Reflection of electrons by a crystal of nickel, *Nature* **119**, 558-560 (1927).
- [24] C. J. Davisson, The diffraction of electrons by a crystal of nickel, *Bell System Tech Journal* **7** (1): 90-105, (January 1928).
- [25] J. A. Wheeler and W. H. Zurek, in *Quantum Theory and Measurement*, by J. A. Wheeler, W. H. Zurek, Eds. (Princeton Univ. Press, Princeton, NJ, 1984), 182-213.
- [26] V. Jacques, E. Wu, F. Grosshans, F. Treussart, P. Grangier, A. Aspect, and J.R. Roch, Experimental realization of Wheeler's delayed-choice gedanken experiment, *Science*, **315**, 966-968 (Feb. 16, 2007); DOI: 10.1126/science.1136303
- [27] A. Peruzzo, P. Shadbolt, N. Brunner, S. Popescu and J. L. O'Brien, A quantum delayed-choice experiment, *Science* **338**, 634-637 (2012); DOI: 10.1126/science.1226719
- [28] F. Kaiser, T. Coudreau, P. Milman, D. B. Ostrowsky, and S. Tanzilli, Entanglement-enabled delayed-choice experiment, *Science* **2**, 637-640, November 2012. [DOI:10.1126/science.1226755].
- [29] H. Kaiser, R. Clothier, S. A. Werner, H. Rauch, H. and H. Wölwitsch, Coherence and spectral filtering in neutron interferometry, *Physical Review A* **45**, 31-42 (1992).

Author's biography with Photo

**Lewis E. Little****Jeffrey H. Boyd**

Dr. Boyd was born in 1943 in northern New Jersey, USA, the son of a factory worker family in which no one had ever been to college. In high school he helped his father dig a basement by hand, using a pick, shovel and wheelbarrow. As a teenager he and his cousin, Lewis E. Little, played three dimensional tic-tac-toe, and developed strategies for four dimensional tic-tac-toe. Boyd chose which college to apply to based on Little's advice about which had the best Applied Math department. Boyd's undergraduate degree in mathematics was from Brown University in 1965, three years after Little graduated from Brown in physics. Following Dr. Martin Luther King in the Civil Rights movement, Boyd was in Mississippi in 1965, where he learned that being denounced as an outside agitator did not mean one was doing the wrong thing. Boyd has post-graduate degrees from Harvard, Yale and Case Western Reserve Universities, has served on the research faculty

of the National Institutes of Health for seven years, and has been on the faculty of the Yale Medical School. His day job is as a physician: a psychiatrist. Boyd retired after a quarter century at Waterbury Hospital, Waterbury CT, a Yale teaching hospital at which he served as chairman of behavioral health and chairman of ethics. Fifty five years ago Boyd abandoned his first love (mathematics) because of his belief that no mathematician over the age of 25 ever discovered anything important, and he was rapidly approaching that age. He wanted to be in a field where age and experience counted for you, not against you. A rewarding career in medicine followed. Then Andrew Wiles proved Fermat's last theorem at age forty and Lewis Little discovered elementary waves at age fifty-two. With this series of articles in *JAP* the author discovered, to his astonishment, that even this old dog can learn some new tricks. Boyd has published in the *New England Journal of Medicine*, *Journal of Advances in Physics*, *Journal of Advances in Mathematics* and *Physics Essays*.