



IMPACT OF PRESSURE ON THE PERFORMANCE OF PROTON EXCHANGE MEMBRANE FUEL CELL

M.Muthukumar^{1*}, P.Karthikeyan², Mathews Eldho¹, P.Nagarathinam¹,
E.P.Panneer Selvam¹, R.Prasanna¹

¹Department of Mechanical Engineering, Nandha Engineering College, Erode-638052, India

²Department of Automobile Engineering, PSG College of Technology, Coimbatore-641004, India

*Corresponding author e-mail : muthpsgtech@gmail.com

ABSTRACT

The performance of the Proton Exchange Membrane (PEM) fuel cell is measured with respect to the power output of the PEM fuel cell. The power output of PEM fuel cell is not only depending on temperature but also depending on the operating pressure. In this paper, the power output of the PEM fuel cell is analyzed by varying the operating pressure. The PEM fuel cell with serpentine flow field was modeled using Solidworks software and analyzed using ANSYS software. From the analysis of three different pressures on the PEM fuel cell, the optimum operating pressure was found. The peak power density occurs at the pressure of 2 bar and operating temperature of 323 K. The best cell potential was also found in this paper

Keywords

PEM, pressure, peak, performance, power

INTRODUCTION

In current scenario the major problem faced by every country is the environmental pollution. To reduce the pollution, we need an alternative source rather than fossil fuels. To produce a clean environment, the world need alternative resources which has zero emission, reduce the pollution, fossil fuel depletion and enhancement of fuel supply. Fuel cell is concerned as the best alternative resource in recent years owing to their advantages.

The proton exchange membrane (PEM) fuel cell is a device which is used to convert chemical into electrical energy. At the anode, hydrogen is fed to the cell and a reaction takes place at the catalyst layer as below.



The protons travel from side to side the polymeric membrane and react with the oxygen and the electrons at the cathode catalyst layer as below.

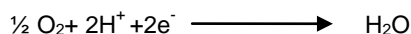

Therefore, the overall reaction taking place in the PEM fuel cell is:



The PEM fuel cell has many advantages. It is relatively operated at low temperature upto 100°C, offer quick start up times. It requires only hydrogen and oxygen to operate. In this PEM fuel cell less chance of pollution as compare to other source of energy because output will be water. It is eco-friendly power generating system. It is suitable for both portable and stationary applications due to high energy density and low operating temperature range. Ibrahim Dincer [1] studied Assessments of the sustainability of processes and systems, and efforts to improve sustainability, should be based in part upon thermodynamic principles, and especially the insights revealed through exergy analysis. Renewable energy utilization in hydrogen production can provide a potential solution to current environmental problems.

Effects of design and operating parameters

Hong Liu et al. [2] compared various flow field design from among all serpentine is the best design. P. Karthikeyan et al. [3] optimized operating condition and design parameter by using Taguchi method will improve the performance of PEM fuel cell. A.P. Manso et al. [4] work, the authors present a thorough review on the influence of geometric parameters of the flow field on the performance of a PEM fuel cell. Tanmay Basak et al. [5] analyzed numerically the natural convection within porous trapezoidal enclosures for various inclination angles. The various parameters influencing the performance of PEM fuel cell was analyzed using ANSYS [6].

The performance of the PEM fuel cell is majorly depending on the channel length and number of channel. Feser et al. [7] concluded that, in a single serpentine flow field geometry, the percentage of flow passing through the GDL is based on the material and geometric parameters of bipolar plates. The convection was slightly depending upon the gas diffusion layer geometry. When the length of the flow channel was increased, the convective flow was also greater than before. The performance of the square type of PEM fuel cell has more benefits than the rectangular cross sectional area of the cell. Shimpalee et al. [8] concluded that the performance is majorly depending upon the flow path and the length of the flow path. The performance of the PEM fuel cell overall is depending on the fluid flow channel. The 3-channel flow, 6-channel

flow and 13-channel flow were analyzed. When 6-channel flow field is compared with 13-channel flow there is a slight performance increment that is considered by the uniform current density distribution and lower water flooding effect.

Hontan E et al.[9] analyzed the different flow channel cross section shapes such as semi-circular, trapezoidal and triangular. The rectangular cross section shape has more advantage than the both of the channels. Wang Xiao-Donget al. [10] analyzed the tapered flow channel at cathode with the active area of 81 mm² and compared to the straight channels. The cell power output of the optimized flow channel had the increment of 11.9 over the straight flow channels. Lin et al. [11] investigated the taper flow channel designs and the diverging channel designs. Both diverging and taper channel designs improved the performance of the fuel cell because of the local oxygen transport rate and the further advantage of the diverging channel was to minimize the fluid leakage at outlet. Erasmo Mancusi et al. [12] analyzed a three dimensional mathematical model of the fuel cell flow channel at different temperatures with different taper angles. The tapering effect has increased the power density, due to the increase in the gas velocity. Also the effect of hydrophobicity of the gas diffusion layer was studied that plays in liquid water formation. When the contact angle decreases, the film formation is increased. A novel cathode flow field with porous carbon inserts along the rib of the cathode flow field was studied by karthikeyan et al. [13-14]. The tubular plates in PEM fuel cell was studied by Sierra et al. [15]. Due to the reduction in flow path angle and the twist of the flow channels, there is a easy removal of water from the gas diffusion layer, thereby improves performance can be obtained. Preeyaphat Wawdee et al. [16] studied the new flow field with up and down slanted flow channels of PEM fuel cell with bigger active area for performance improvement. The different landing width and the channel width of 0.5x0.5, 1x1, 1.5x1.5 and 2x2 mm were studied by Muthukumar et al. [17]. They found that the PEM fuel cell with landing to channel width of 0.5 x 0.5 mm can give the better performance. The performance of different passes of serpentine flow field was analyzed by Muthukumar et al. [18] using three dimensional PEM fuel cell.

MODEL CREATION OF PEM FUEL CELL

The 3D mathematical model of serpentine channeled and rectangular outlet flow channel PEM fuel cell is created as shown in Fig.1, Fig.2 & Fig.3. It consists of the membrane, flow channels on anode and cathode, catalyst layers and gas diffusion layers in both anode and cathode. The Fig.1 displays the 3D model of PEM fuel cell with serpentine flow channel design with curved bend. By using the Volume of fluid method, the model is created. The dimensions of the flow plate is 80 mm x 80 mm. The inlet and outlet diameter are 2 mm. The flow channel width and height are taken as 2 mm. The rib width is also taken as 2 mm. The active area of PEM fuel cell is 25 cm². The parameters of serpentine channel PEM fuel cell is listed in Table 1.

Table 1. Dimensions of PEM fuel cell model

| S.NO. | PARAMETER | VALUE |
|-------|-----------------------------|--------------------|
| 1 | Channel length | 50 mm |
| 2 | Outlet channel height | 2 mm |
| 3 | Inlet channel height | 2 mm |
| 4 | Thickness of catalyst layer | 0.08 mm |
| 5 | Thickness of GDL | 0.3 mm |
| 6 | Thickness of membrane | 0.127 mm |
| 7 | Active area | 25 cm ² |

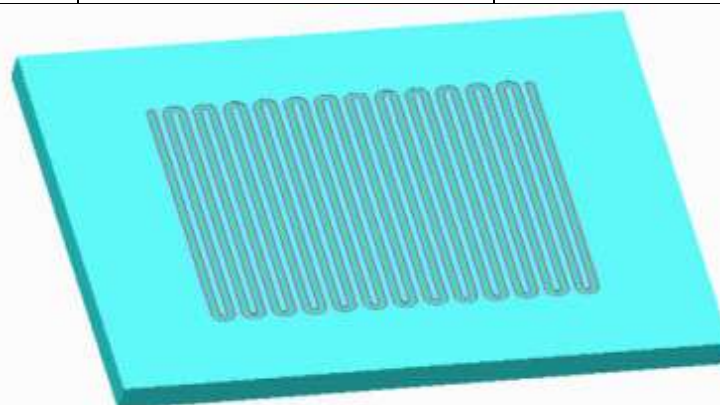

Fig. 1: Model of serpentine channel flow field of PEM fuel cell

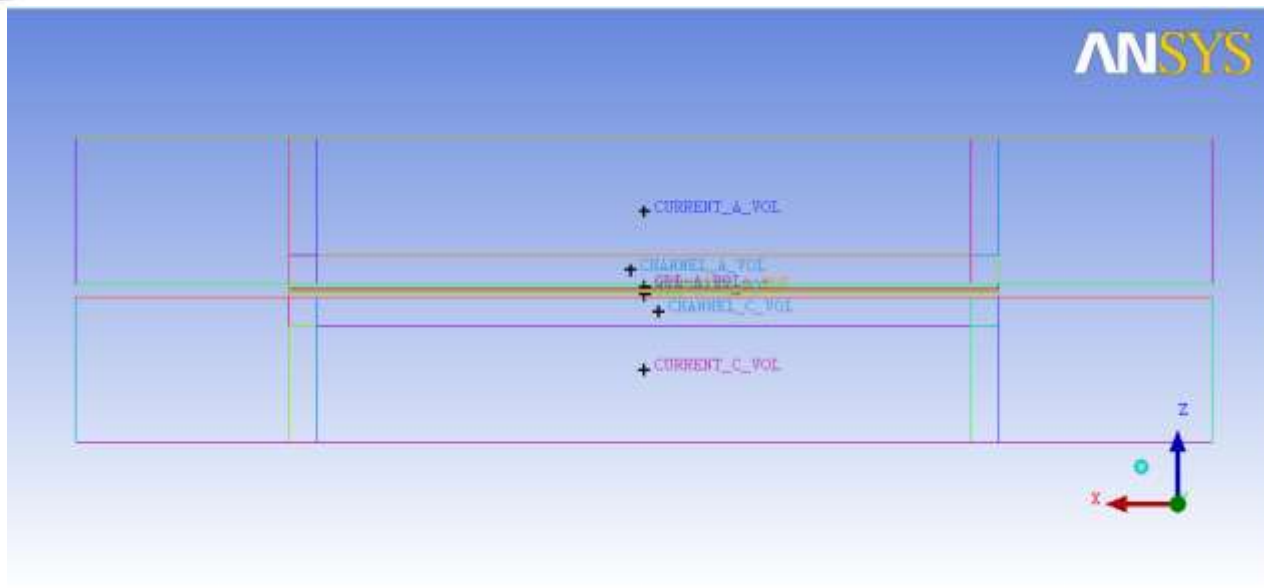

Fig. 2: Side view of serpentine channel flow field

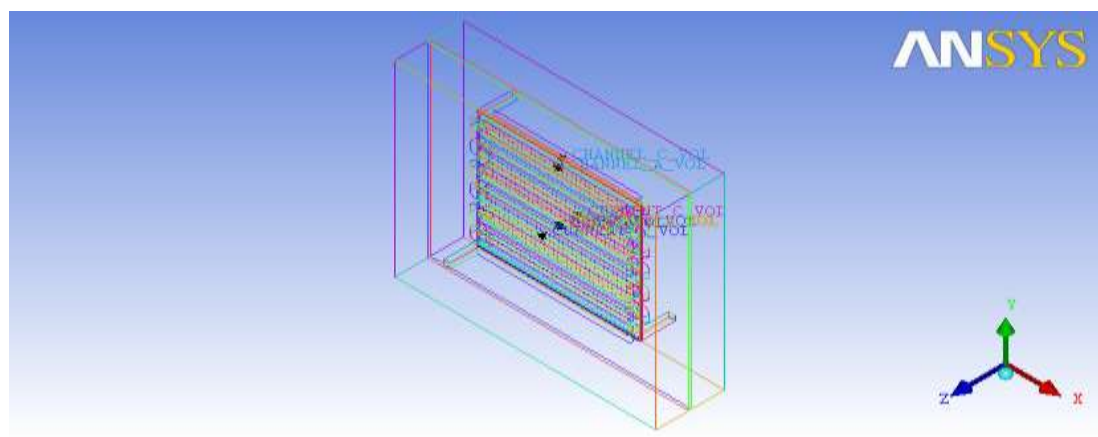

Fig. 3: Isometric view of serpentine channel flow field PEM fuel cell

SOLVER

A control volume approach based on commercial solver FLUENT 14.5 was used to solve the various governing equations. Before that, according to the dimension, the 3D model of PEM fuel cell was made using SOLID WORKS 14.0 and meshed using ICEM CFD 14.5 as shown in Fig.4. Later, the analysis was done with three different pressure (1 bar, 1.5 bar, 2 bar) and voltage (0.25 V-0.85 V) at constant temperature of 323 K (50°C) using Ansys and checked.

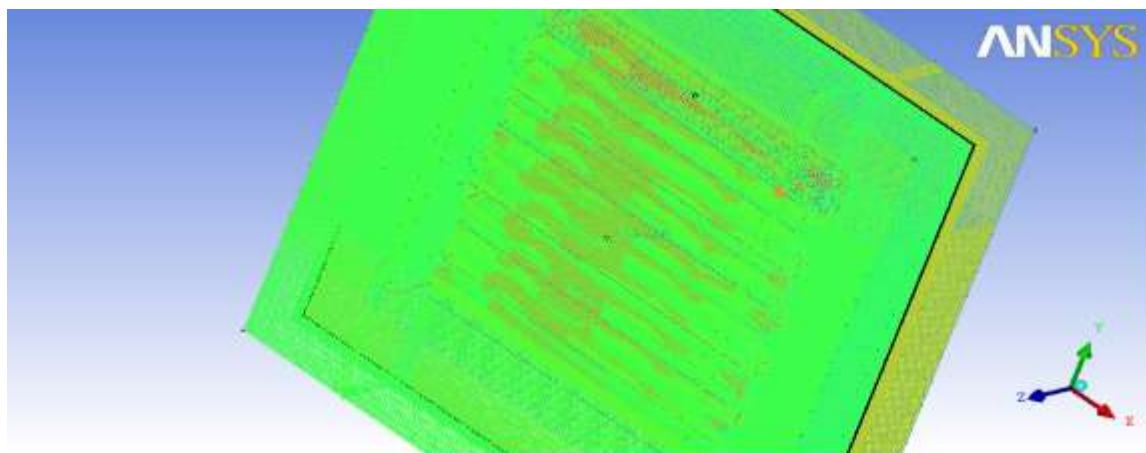

Fig. 4: Meshing of model



RESULT AND DISCUSSION

The influence of various operating pressure with different cell voltages were analyzed for serpentine U bend flow channel. From the entire three results, 0.55 V with pressure of 2 bar gives high performance as compared to others. For 1 bar with 0.55 V, the current density was found to be 1.206385 A/cm² and the power density was found to be 0.66351175 W/cm². For 1.5 bar with 0.55 V, the current density was found to be 1.206648 A/cm² and the power density was found to be 0.6636564 W/cm². For 2 bar with 0.55 V, the current density was found to be 1.207008 A/cm² and the power density was found to be 0.6638544 W/cm². These values are tabulated in Table 2. While comparing the performance of PEM fuel cell with three different pressures and at constant temperature, it was found that the pressure 2 bar is the optimum pressure at the cell potential of 0.55 V. The Fig.5, Fig.6 and Fig.7 show the numerical results at 1 bar, 1.5 bar and 2 bar respectively.

Table 2. Comparison of results

| S.No. | Pressure (bar) | Voltage (V) | Current density (A/cm ²) | Power density (W/cm ²) |
|-------|----------------|-------------|--------------------------------------|------------------------------------|
| 1 | 1 | 0.55 | 1.206385 | 0.66351175 |
| 2 | 1.5 | 0.55 | 1.206648 | 0.6636564 |
| 3 | 2 | 0.55 | 1.207008 | 0.6638544 |

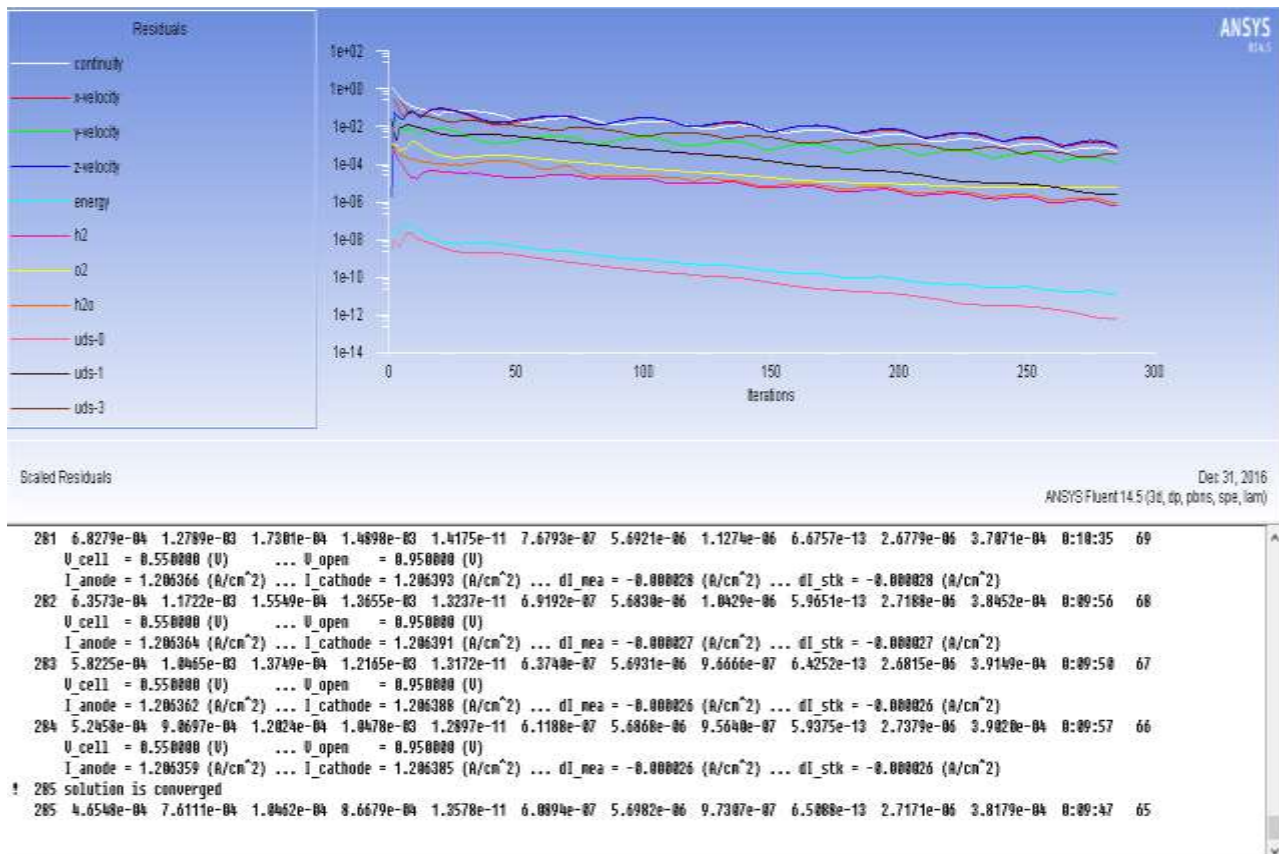

Fig. 5: Result for pressure of 1 bar at 0.55V

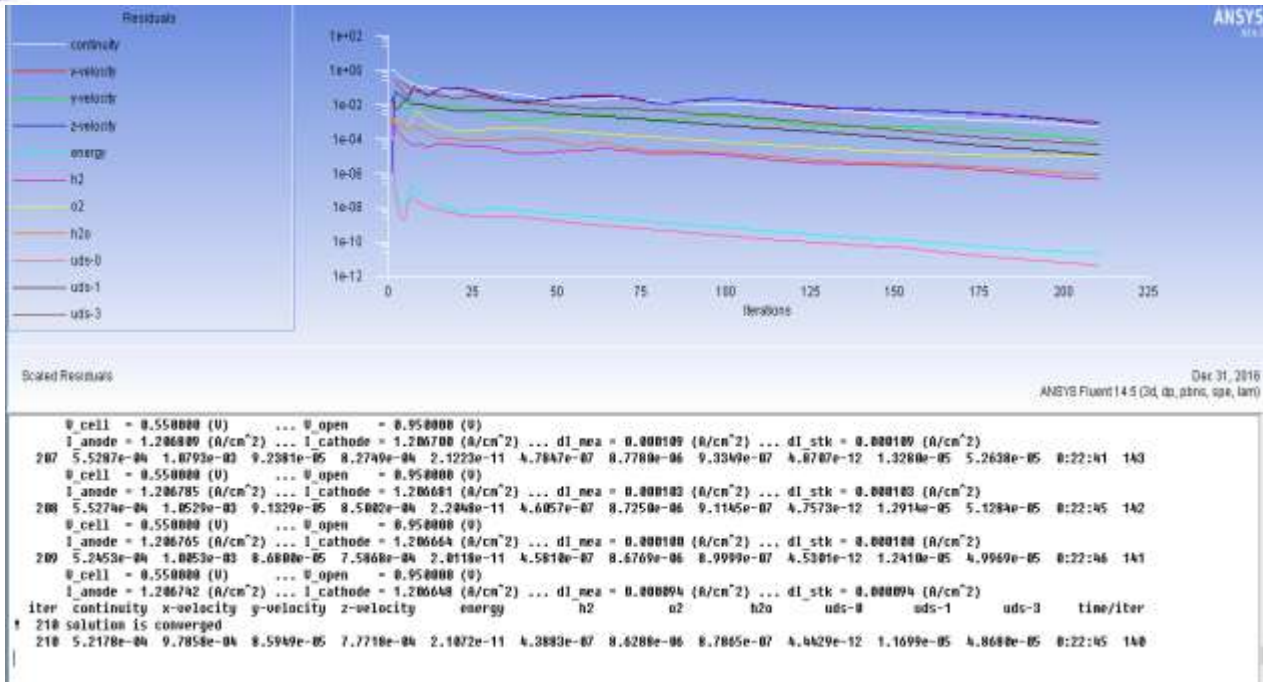

Fig. 6: Result for pressure of 1.5 bar at 0.55V

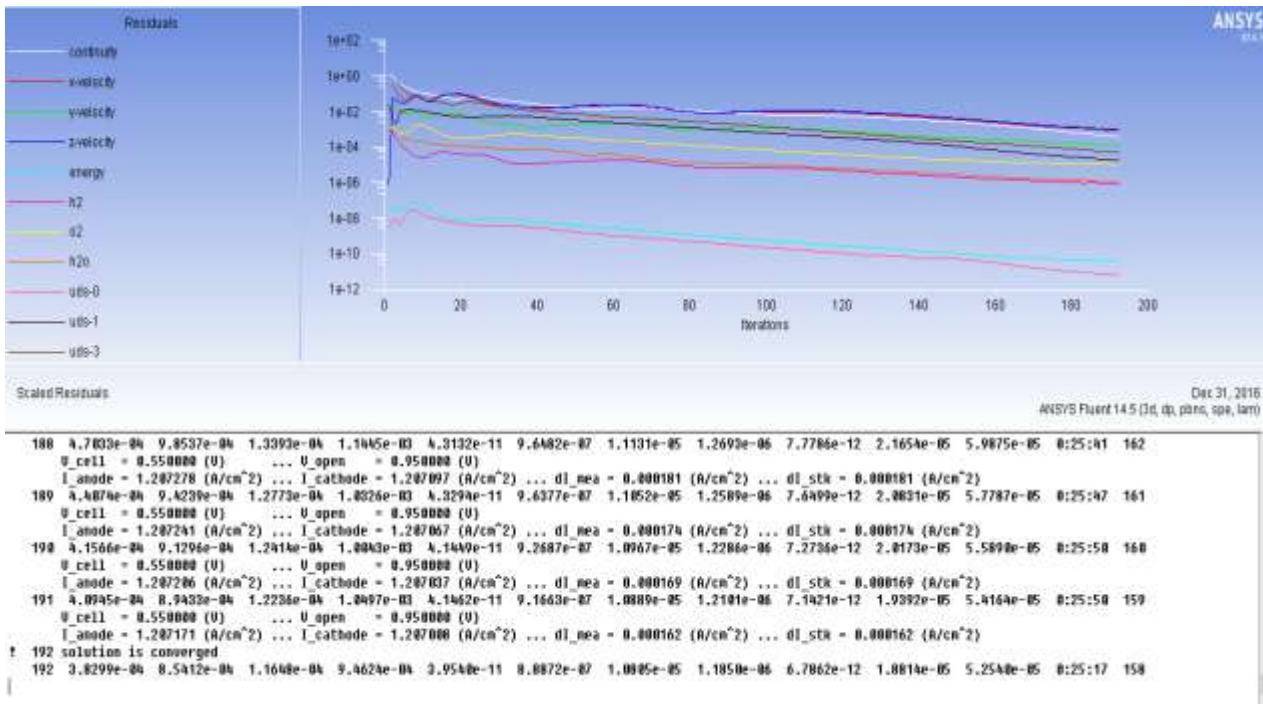

Fig. 7: Result for pressure of 2 bar at 0.55V

CONCLUSION

The power density and performance of PEM fuel cell are influenced by many parameters like temperature, pressure, mass flow rate, humidity of input gases etc. In this paper, the effect of pressure on the performance of PEM fuel cell was analyzed numerically. The PEM fuel cell with active area of 25 cm² and serpentine type flow field with U bend was modeled using SolidWorks 14.0; and meshing and analysis were done using Ansys 14.5 software packages. The PEM fuel cell with three different pressures of 1 bar, 1.5 bar and 2 bar with constant temperature of 323 K is analyzed. From the numerical results, it is found that 2 bar pressure at 323 K is giving the best power output and performance of PEM fuel cell potential at 0.55 V cell potential.



REFERENCES

1. Ibrahim Dincer. 2008 Hydrogen and Fuel Cell Technologies for Sustainable Future. Jordan Journal of Mechanical and Industrial Engineering. Vol. 2. pp. 1-14.
2. Hong, Liu., Peiwen, L. i., Daniel, Juarez-Robles., Kai, Wang and Abel Hernandez-Guerrero. 2014 Experimental study and comparison of various designs of gas flow fields to PEM fuel cells and cell stack performance. Frontiers in energy research. Vol. 2. pp. 1-8.
3. Karthikeyan, P., Muthukumar, M., Vignesh Shanmugam, S., Pravin Kumar, P., Suryanarayanan Murali, and Senthil Kumar, A. P. 2013 Optimization of Operating and Design Parameters on proton Exchange Membrane Fuel Cell by using Taguchi method. Procedia Engineering. Vol. 64. pp. 409-418.
4. Manso, A. P., Marzo, F. F., Barranco, J., Garikano, X., and Garmendia Mujika, M. 2012 Influence of geometric parameters of the flow fields on the performance of a PEM fuel cell. A review. Journal of Hydrogen energy. Vol. 37. pp.15256-15287.
5. Tanmay Basak, Roy, S., Sandeep Kumar Singh., and Pop, I. 2009 Finite element simulation of natural convection within porous trapezoidal enclosures for various inclination angles: Effect of various wall heating. Journal of Heat and Mass Transfer. Vol. 52. pp. 4135-4150.
6. Nandhakumar, V., Muthukumar, M., and Senthil Kumar, A. P. 2016. Analysis of Parameters Influencing the Performance of PEM Fuel Cell by Ansys. International Journal of Advanced and Innovative Research. Vol.5. pp.2278-7844.
7. Feser, J. P., Prasad, A. K., and Advani, S. G.2006. On the relative influence of convection in serpentine flow fields of PEM fuel cells. Journal of Power Sources. Vol. 161. pp. 404-412.
8. Shimpalee, S., Greenway, S., and Van Zee, J. W. 2006 The impact of channel path length on PEMFC flow-field design. Journal of Power Sources. Vol. 160. Pp. 398406.
9. Hontanón, E., Escudero, M. J., Bautista, C., García-Ybarra, P. L., and Daza, L. 2000. Optimisation of flow field in PEM fuel cell using CFD techniques. Journal of Power Sources. Vol. 86. pp. 363-368.
10. Wang Xiao-Dong., Huang Yu-Xian., Cheng Chin-Hsiang., Jang Jiin-Yuh., Lee Duu-Jong., and Yan Wei-Mon. An inverse geometry design problem for optimization of single serpentine flow field of PEM fuel cell. International Journal of Hydrogen Energy. Vol. 35. pp. 4247-4257.
11. Lin Lin., Zhang XinXin., Feng Hu Ting., and Wang Xiao-Dong. 2010. Optimization of a serpentine flow field with variable channel heights and widths for PEM fuel cells. Science China Technological Sciences. Vol. 53. pp. 453-460.
12. Erasmo Mancusi., Eliton Fontana., Antonio Augusto Ulson de Souza., Selene M.A., and Guelli Ulson de Souza 2014. Numerical study of two-phase flow patterns in the gas channel of PEM fuel cells with tapered flow field design. Vol.39. pp. 2261-2273.
13. Karthikeyan P, Vasanth RJ, Muthukumar M. 2015. Experimental investigation on uniform and zigzag positioned Porous inserts on the rib surface of cathode flow channel for performance enhancement in PEMFC. International Journal of Hydrogen Energy, Vol. 40, pp.4641-4648
14. Karthikeyan P, Muthukumar M, Vasanth RJ. 2016. Influence of porous carbon inserts on scaling up studies for performance enhancement on PEMFC. International Journal of Hydrogen Energy, Vol. 40, pp.4641-4648
15. Sierra JM, Figueroa-Ramírez SJ, Díaz SE, Vargas J, Sebastian PJ. 2014, Numerical evaluation of a PEM fuel cell with conventional flow fields adapted to tubular plates. Int J Hydrogen Energy, Vol. 39. pp.16694-16705.
16. Wawdee Preeyaphat, Limtrakul Sunun, Vatanatham Terdthai, Fowler Michael W. 2015. Water transport in a PEM fuel cell with slanted channel flow field plates. International Journal of Hydrogen Energy. Vol.30, pp. 1-10.
17. M.Muthukumar, P.Karthikeyan, M.Vairavel, C.Loganathan, S.Praveenkumar, A.P.Senthil Kumar, 2014. Numerical Studies on PEM Fuel Cell with Different Landing to Channel Width of Flow Channel, Procedia Engineering, Vol.97, pp. 1534 – 1542.
18. M.Muthukumar, P.Karthikeyan, V.Lakshminarayanan, A.P.Senthil Kumar, M.Vairavel, R.Girimurugan, 2014. Performance studies on pem fuel cell with 2, 3 and 4 pass serpentine flow field designs. Applied Mechanics and Materials. Vol.. 592-594, pp. 1728-1732.



This work is licensed under a Creative Commons Attribution 4.0 International License.