



RESEARCH ARTICLE

Survey on Wireless Indoor Positioning Systems

Wisam Hasan Ali*, Amnah Abas Kareem, Manal Jasim

Department of Electrical Engineering, University of Technology, Baghdad, Iraq

ABSTRACT

Indoor positioning has finally testified a rise in interest, thanks to the big selection of services it is provided, and ubiquitous connectivity. There are currently many systems that can locate a person, be it wireless or by mobile phone and the most common systems in outdoor environments is the GPS, the most common in indoor environments is Wi-Fi positioning technique. The improvement of positioning systems in indoor environments is desirable in many areas as it provides important facilities and services, such as airports, universities, factories, hospitals, and shopping malls. This paper provides an overview of the existing methods based on wireless indoor positioning technique. We focus in this survey on the strengths of these systems mentioned in the literature discordant with the present surveys; we also assess to additionally measure various systems from the scene of energy efficiency, price, and following accuracy instead of comparing the technologies, we also to additionally discuss residual challenges to correct indoor positioning.

Keywords: Indoor localization, indoor positioning, received signal strength indicator, Wi-Fi

INTRODUCTION

The widespread proliferation of smartphones and different wireless device within past years has resulted in an exceeding range selection of services as well as indoor positioning. Indoor positioning technique is the method of finding a device or user position in an interior setting. Indoor device positioning technique has been achieving a widespread the previous few decades; positioning technique has large-scale applications in the health sector, disaster, industry, management,^[1] surveillance, building management, and a number of several other sectors. So as to currently the studies and also the business spotlight is on rising technologies, like Wi-Fi, ultra-wideband (UWB), Zigbee, Bluetooth, etc. Due to, Wi-Fi fingerprinting is based on the (received signal strength indicator [RSSI]) that oblivious from each of the wireless access points that are available and on comparisons to a reference database. Therefore, the position of a device is commonly determined by calculating the distance or the likeness between a fingerprint collected by the device and the fingerprints contained in the reference database.^[2] Wi-Fi fingerprinting is a complex subject and suffers from received signal strength (RSS) difference problem causes by environmental changes that are ingrained in both the training and positioning phases.^[3] Due to, they proposed a smartphone-based, indoor pedestrian-tracking system and they analyze various sides of the RSS difference when using smartphones.^[4] They propose a new algorithm based on an improved double-peak Gaussian distribution for Wi-Fi fingerprinting, and the results show the algorithm can improve the positioning accuracy at about 20%.^[5] However, they present Magicol, an indoor positioning and tracking system, and they did an in-depth study on the incorporation

of magnetic and Wi-Fi signals. The incorporation with Wi-Fi leads to 90 percentile accuracy.^[6] They provided a survey of the existing methods based on smartphone that includes Wi-Fi, Bluetooth, and magnetic field fingerprinting and described the technologies and position estimation methods of these technology components.^[7] They used deep neural networks and employ the Dotnetnuke system for classification building/floor while still attained satisfactory results.^[8] This leads to obtain a more accurate position they combine the method of fingerprint and K-nearest neighbor (kNN) method, where the classification of positions is made from some RSS data that obtained from some AP that subsist around the user's position.^[9] Therefore, they attempted to establish a bidirectional link between Internet of things and indoor positioning also they discussed challenges to accurate indoor positioning.^[10] Therefore, they presented WiDeep combines a stacked reduce the noise of the autoencoder deep learning the model and a probabilistic framework to controlled the noise in the received Wi-Fi signal. This survey focuses on wireless technology indoor positioning system.

Corresponding Author:

Wisam Hasan Ali, Department of Electrical Engineering, University of Technology, Baghdad, Iraq. E-mail: 30088@uotechnology.edu.iq

Received: Apr 20, 2019

Accepted: Apr 24, 2019

Published: Aug 20, 2019

DOI: 10.24086/cuesj.v3n2y2019.pp42-47

Copyright © 2019 Wisam Hasan Ali, Amnah Abas Kareem, Manal Jasim. This is an open-access article distributed under the Creative Commons Attribution License.

This paper aims to make an available general overview of past work at the side of a beginning platform for future adds this promising however difficult space. In section 2, we discuss different techniques for indoor positioning. Section 3, we offer different technologies specializing in wireless technologies for indoor positioning. Sections 4, we offer many of the criteria which will be used to evaluating the performance of an indoor positioning system. Finally, section 5, we provide the conclusion of the survey.

Table 1 presented a list of abbreviations used in this paper.

INDOOR POSITIONING METRICS

During this section, we discuss different criteria measurements for signal in the positioning system.

RSS

It is one of the most commonly used standards in indoor environments positioning.^[11,12] Is the actual signal strength received in the receiver and measured in milliwatt or ordBmW? As for RSSI is that the RSS indicator, a relative measurement of the RSS that has generally defined by each chip vendor, for example, the Cisco uses a range of Wi-Fi chipset between 0 and 100, while Atheros uses RSSI values between 0 and 60.

It is potential to understand the distance by employing a variety of various signal propagation models given the ability at the reference or transmission power that is famed by utilize, the RSSI and an easy path-loss propagation model,^[13] the spaced between transmitter (Tx) and receiver (Rx) is often calculable from Equation (1),

$$RSSI = -10 n \log_{10} (d) + A \quad (1)$$

Where n is that the path loss exponent (which range from four in indoor environments to two in free space), and A is that the RSSI at a reference range from the receiver. Whereas

Table 1: A list of abbreviation used in this paper

AoA	Angle of Arrival	RSSI	Received signal strength indicator
PoA	Phase-of-Arrival	GPS	Global positioning system
dBm	decibel-milliwatts	LOS	Line-of-Sight
RFID	Radio-frequency identification	CSI	Channel state information
LBS	Location-based services	RF	Radio frequency
RN	Reference node	kNN	k-Nearest Neighbors
Rx	Receiver	ToF	Time-of-Flight
S	Distance	UWB	Ultra-wideband
MBL	Mobile-based localization	Tx	Transmitters
SVM	Support vector machine	DBL	Device-based localization
BLE	Bluetooth Low Energy	Ns	Nanosecond
MAC	Medium access control	OFDM	Orthogonal frequency-division multiplexing

the RSS primarily based approach is uncomplicated, cheap and energy efficient, it suffers from poor positioning accuracy thanks to further signal attenuation ensuing from transmission through walls and severe RSS fluctuation alternative massive obstacles and indoor noise.^[11,14] Completely different filters or averaging mechanisms will be accustomed mitigate these effects. However, to get high positioning, accuracy will be used with algorithms.

Channel State Information (CSI)

In IEEE 802.11 and UWB, and several wireless systems, the channel frequency is selective frequencies exhibit different amplitude and part behavior due to the coherence information measure of the wireless channel is smaller than the information measure of the signal. Nowadays, several IEEE 802.11 NICs cards will offer subcarrier-level channel measurements for orthogonal frequency division multiplexing systems more stable measurements and better positioning accuracy.

Fingerprinting

Fingerprinting: Primarily, the main positioning techniques need to be scanned for environmental features of the environment.^[15,16] Initially, RSS is measured in two phases; then the measurements are compared in the online phase with the offline phase to determine the location of the person. There are a number of accessible algorithms that can be discussed below:

kNN

These algorithms utilized if the distances are adopted as weights in the signal space, and based on the RSSI utilized root mean square error.^[17]

Neural networks

Neural networks are used in many prediction and classification situations. When using a neural network in an indoor positioning system, neural network is trained on RSS values and coordinates obtained in the offline phase.^[18-20] The

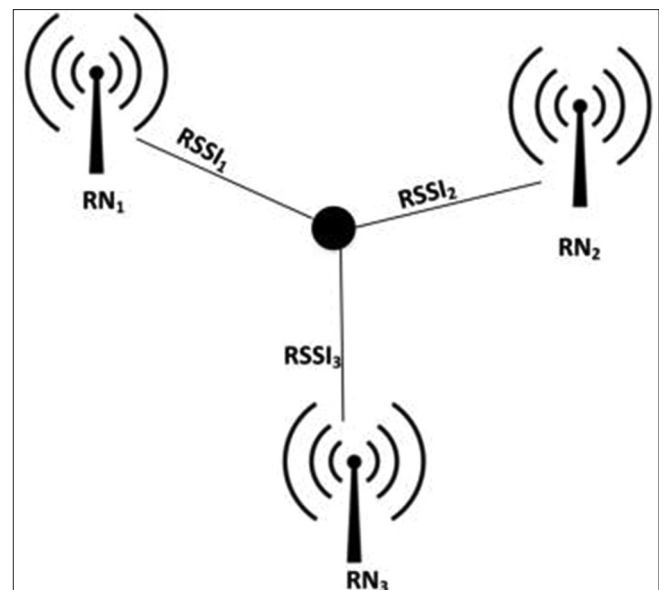

Figure 1: Received signal strength indicator based positioning^[11]

AQI

perceptron multilayer network (Multilayer Perceptrons) with a hidden node layer is one among the remarkably used ANN positioning.^[17]

Support vector machine (SVM)

It is one of the most common approaches to regression and data classification. SVM, they are used extensively in the field of machine learning with great accuracy.

The Angle of Arrival (AOA)

Primarily, AOA approaches to estimate the angle at that the transmitted signal impact on the receiver utilize antennae arrays.^[9] Although AoA will offer associate correct estimation once the transmitter-receiver distance is small, whereas its accuracy deteriorates with an increase within the transmitter-receiver distance. Moreover, because of multipath effects in indoor environments, the AoA in terms of line of sight (LOS) is commonly exhausting to get.

Table 2 provides an outline of the techniques mentioned.

INDOOR POSITIONING TECHNIQUES

In this section, we will present and discuss the different existing technologies that have been utilized to provide indoor positioning services.

Wi-Fi

IEEE 802.11, called Wi-Fi, works within the scientific, medical, and industrial (Industrial Scientific Medical [ISM]) domain and is originally accustomed to giving internet property and

networking for multiple devices publicly, non-public and business environments. In the first place, the Wi-Fi network had a reception vary of regarding 100 m^[17] that have currently inflated to regarding 1 km^[21] in IEEE 802.11 ah. Wi-Fi is enabled, most laptops, smartphones, and other portable user devices, creating Wi-Fi, a perfect candidate for indoor positioning and one in every of the foremost specific positioning technologies in literature.^[14,22-24] Since Wi-Fi access points can also be used as reference points,^[25] basic positioning systems can be built while not the requirement for extra infrastructure. In addition, uncontrolled interference in the ISM domain has been shown the affect on positioning accuracy.^[22] The preceding RSS, CSI, and AoA technologies or any combination of them can be defined as mixed methods. Recent Wi-Fi-based positioning systems^[22,23,25] have achieved an average positioning accuracy of up to 23 cm.^[23] For elaborate info regarding Wi-Fi, we direct the reader to go.^[26,27]

Bluetooth

Bluetooth (IEEE 802.15.1) is a formation medium access that control between layers and physical specifications in order to link several mobile or multiple wireless devices among a selected personal space. The most recent version of Bluetooth, such as Bluetooth smart additionally called Bluetooth low energy (BLE), as will give a higher power potency and improved data rate of 24 Mbps with a coverage range of 70–100 m with. Apple proclaimed the iBeacons program at the World Software Developers Conference,^[28] whereas it is utilized with different positioning techniques such as RSSI and AoA.^[29,30] The protocol permits the device that supports BLE to send signals or signals at periodic intervals. The most disadvantages of iBeacons are

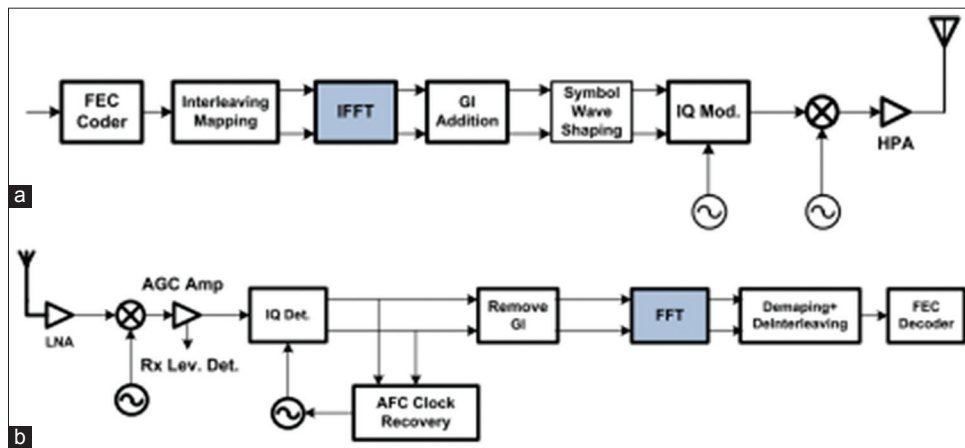

AQ1 Figure 2: Orthogonal frequency division multiplexing (a) transmitter and (b) receiver block diagram^[9]

Table 2: Outline of the most common indoor positioning techniques

Techniques	Advantages	Disadvantages
RSSI	Easy to implement, is used with a variety of techniques, cost-effective	Prone to multipath weakening and lower positioning accuracy, environmental noise, will want fingerprinting
CSI	More powerful for multi-track and indoor noise	Not readily available on ready NICs
AoA	Can provide high positioning, does not require any print, accuracy	Might need directional antennas, and the comparatively sophisticated algorithms and perhaps needs intricacy hardware
Fingerprinting	Partly easy during use	The new fingerprinting is needed even if there is a slight difference in space

RSSI: Received signal strength indicator, CSI: Channel state information, AoA: Angle of arrival

that the delayed reporting and reporting on RSS may require an important period of time positioning challenges. Whereas iBeacons were intended to produce early detection, it was conjointly used for indoor positioning.

Radio-Frequency Identification Device (RFID)

RFID is the transmission and storage of data using electromagnetic transmitters from the transmitter to any appropriate radio frequency circuit.^[31] RFID consists of a reader who can communicate with RFID tags. There are two basic types of RFID: Active RFID and passive RFID systems.

Active RFID

Active RFID operates in the microwave and ultra-high frequency band. Active RFID can be used for positioning.

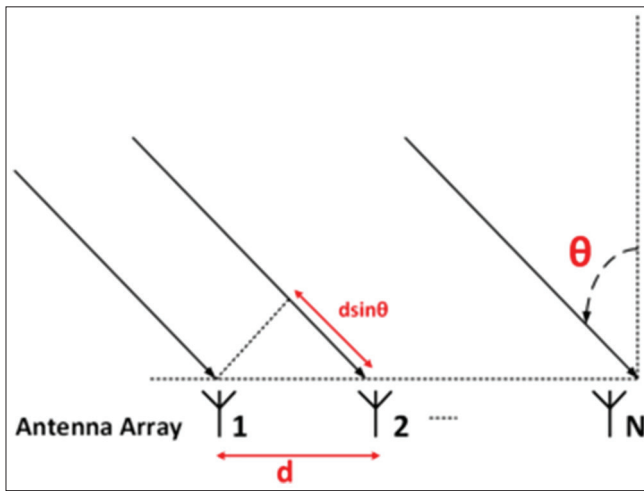

AQ1 Figure 3: Angle of arrival positioning^[9]

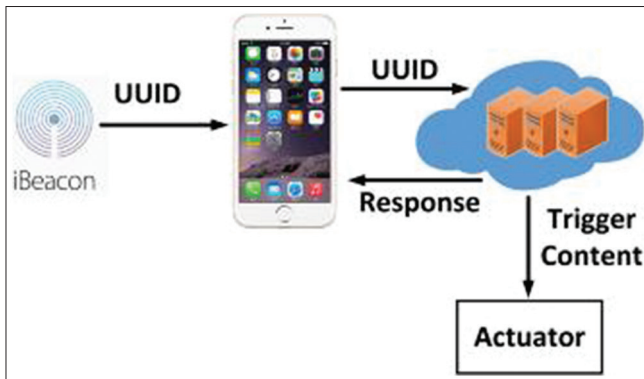

AQ1 Figure 4: Model architecture for iBeacon systems^[28]

Passive RFID

Passive RFID is limited in communication range (1–2 m). They are lighter, smaller, and less expensive than active devices, but their limited range makes them unsuitable for indoor positioning.

Table 3 provides an outline of the many wireless technologies from a positioning perspective.

APPLICATIONS OF INDOOR POSITIONING SYSTEM 4

Indoor positioning technology has recently seen a major increase in usage around the world. Some applications within the following:

Marketing and Customer Assistance

Marketing is an essential part of any business because it makes it easier for you to improve your product and brand image. Positioning based marketing is fundamentally revolutionary in a world of marketing that improves profits and promotes sales. Major airports such as London Heathrow Airport, Tokyo Haneda Airport in Japan, Miami International, John F. Kennedy in New York and many other improve customer experience proximity-based services and use iBeacons.^[32,33]

Health Sector

The health sector can profit significantly from the positioning system because it will facilitate save valuable lives, will support hospital workers, patients, and guests.^[17] The indoor positioning of doctors can also allow many patients to be traced and track their movements to make sure patient safety.^[34] So as, in the event of an emergency, the positioning identifies the employee who is nearby and has the necessary qualifications to deal with the emergency situation. The indoor positioning of doctors can also allow many patients to be traced and track their movements to make sure patient safety.

Security

Indoor positioning can greatly improve the security situation of affairs round the world. So as to can be utilizing positioning system to definition potential threats that may cause security risks.^[15] Using locations, central command can design plans and higher methods that give to troopers within the field.

CHALLENGES

This section, will proposed the most common key challenges that affect the accuracy of the person position.

Table 3: Synopsis of various wireless technologies for positioning

Technique	Max. Range	Advantages	Disadvantages	Energy consumption
IEEE 802.11 n ^[32]	(250) m outdoor	Widely available, high accuracy, does not need complex extra hardware	Prone to noise, needs complex processing algorithms	Moderate
802.11 ac	(35) m indoor			
802.11 ad	couple of meters			
RFID ^[33]	(200) m	It has a wide range	Positioning accuracy is low.	Low

Multipath and Noise Effects

Multipath effects are a major challenge for positioning. Due to the signals intrinsic nature, the signal may be suffering from absorption, refraction, dispersion, reflection from metals, walls, nature of climate, and humans. So as, to get a single signal possibility does not exist. Therefore, for accurate site estimation, complex signal processing techniques that can identify the LOS signal and eliminate the consequences of multiple path signals are needed. However, there is a necessity for improved and efficient multiple noise and noise control algorithms that facilitate to use positioning signals accurately.

Privacy and Security

Privacy is one of the important challenges facing the positioning system for human. Due to not all people have a desire to share their current positions. Until now, current positioning systems do not care much about the problem of privacy, but focus more on the accuracy and efficiency of the system in detecting the person's positioning. However, how the user can trust the system or the positioning service provider? Therefore, it is important to consider privacy and security when working with a person's positioning system.

Cost

Cost is one of the fundamental challenges facing a positioning service. Sometimes need additional infrastructure in indoor environments and link nodes. In addition, some proprietary software, dedicated servers, and databases are require. Despite that, this can be overcome using cellular networks or Wi-Fi or mixing of them.

CONCLUSIONS

This survey, we provided a description of many indoor positioning technologies (WiFi, UWB, etc.) and techniques (AoA, RSSI, CSI, etc.). The default methodology for internal mobility depends on the wireless local area network. Over the years, there has been clear progress in attempts to increase the accuracy of time to enhance accuracy. The positioning accuracy depends on the density of the access points and standardization points and can be appropriate for several in typical public buildings such as shopping malls, universities, and airports. However, under Non-LOS multipath or conditions, the resolution deteriorates dramatically. It is also, this survey discuss a number of internal challenges to the positioning and presented some solutions that could help address these challenges.

REFERENCES

1. A. Zelenkauskaitė, N. Bessis, S. Sotiriadis and E. Asimakopoulou. "Interconnectedness of Complex Systems of Internet of Things Throughsocial Network Analysis for Disaster Management". In Fourth International Conference on Intelligent Networking and Collaborative Systems, IEEE, 2012, pp. 503-508.
2. N. Marques, F. Meneses and A. Moreira. "Combining Similarity Functions and Majority Rules for Multi-building, Multi-floor, WiFi Positioning". International Conference on Indoor Positioning and Indoor Navigation, IEEE, 13-15th Nov 2012.
3. Y. Kim, H. Shin and H. Cha. "Smartphone-based Wi-Fi Pedestrian-Tracking System Tolerating the RSS Variance Problem". International Conference on Pervasive Computing and Communications, IEEE, 19-23 Mar 2012.
4. L. Chen, B. Li, K. Zhao, C. Rizo and Z. Zheng. "An improved algorithm to generate a Wi-Fi fingerprint database for indoor positioning". *Sensors*, vol. 13, no. 8, pp. 1186-1194, 2013.
5. Y. Shu, C. Bo, G. Shen, C. Zhao, L. Li and F. Zhao. "Magical: Indoor localization using pervasivemagnetic field and opportunistic WiFi sensing". *IEEE Journal on Selected Areas in Communications*, vol. 33, pp. 1443-1457, 2015.
6. P. Davidson and R. Piche. "A survey of selected indoor positioning methods for smartphones". *IEEE Communications Surveys and Tutorials*, vol. 19, pp. 1347-1370, 2016.
7. M. Nowicki and J. Wietrzykowski. "Low-effort Place Recognition with WiFi fingerprints Using Deep Learning". Switzerland: Springer, 2017.
8. Y. E. Dari and S. Pranowo. "CAPTURE: A mobile based indoor positioning system using wireless indoor positioning system". *International Journal of Interactive Mobile Technologies*, vol. 12, no. 1, p. 61, 2018.
9. F. Zafari, A. Gkelias and K. K. Leung. "A Survey of Indoor Localization Systems And technologies". IEEE Intelligent Vehicles Symposium IV, 2018.
10. M. Abbas, H. Rizk, M. Elhamshary and M. Torki. "WiDeep: WiFi-based Accurate and Robust Indoor Localization System using Deep Learning". Research Gate, Conference Paper, 2018.
11. Z. Yang, Z. Zhou and Y. Liu. "From RSSI to CSI: Indoor localization via channel response". *Computing Surveys*, vol. 46, no. 2, p. 25, 2013.
12. A. M. Ladd, K. E. Bekris, A. Rudys, L. E. Kavradi and D. S. Wallach. "Robotics-based location sensing using wireless ether net". *Wireless Networks*, vol. 11, pp. 189-204, 2005.
13. S. Nadler, V. Soroka, O. Fuchs, R. Korenshtein and E. Sonsino. "Presence Zones for Contextual Location Based Services". In Innovations in Clouds, Internet and Networks, 2008.
14. J. Xiao, K. Wu, Y. Yi, L. Wang and L. M. Ni. "Pilot: Passive device free indoor localization using channel state information". In DISTRIBUTED Computing Systems, 3rd International Conference on, IEEE, 2013, pp. 236-245.
15. M. Youssef and A. Agrawala. "The Horus WLAN Location Determination System". In Proceedings of the 3rd International Conference on Mobile Systems, Applications, and Services, 2005, pp. 205-218.
16. F. Zafari, I. Papapanagiotou and K. Christidis. "Micro location for internet-of-things-equipped smart buildings". *IEEE Internet of Things Journal*, vol. 3, pp. 96-112, 2016.
17. H. Liu, H. Darabi, P. Banerjee and J. Liu. "Survey of wireless indoor positioning techniques and systems." *IEEE Transactions on Systems, Man, and Cybernetics-Part C: Applications and Reviews*, vol. 37, no. 6, 2007.
18. M. Altini, D. Brunelli, E. Farella and L. Benini. "Bluetooth Indoor Localization with Multiple Neural Networks". 5th IEEE International Symposium, 2010, pp. 295-300.
19. S. Kumar, S. Gil, D. Katabi and D. Rus. "Accurate Indoor Localization with Zero Start-up Cost". In Proceedings of the 20th Annual International Conference on Mobile Computing and Networking, 2014.
20. M. Scherhauf, M. Pichler, D. Muller, A. Ziroff and A. Stelzer. "Phase-of-arrival-based localization of passive UHF RFID Tags". IEEE MTT-S International Microwave Symposium Digest, 2013, pp. 1-3.
21. T. Adame, A. Bel, B. Bellalta, J. Barcelo and M. Oliver. "IEEE 802.11 ah: The Wifi approach for M2M communications". *IEEE Wireless Communications*, vol. 21, pp. 144-152, 2014.
22. D. Vasisht, S. Kumar and D. Katabi. "Decimeter-level Localization with a Single Wifi Access Point". In 13th USENIX Symposium on Networked Systems Design and Implementation, 2016, pp. 165-178.

23. M. Kotaru, K. Joshi, D. Bharadia and S. Katti. "Spotfi: Decimeter level localization using wifi". *SIGCOMM Computer Communication*, vol. 45, pp. 269-282, 2015.
24. M. K. Hoang and R. Haeb-Umbach. "Parameter Estimation and Classification of Censored Gaussian Data with Application to Wi-Fi Indoor Positioning". *IEEE International Conference on Acoustics, Speech, and Signal Processing*, 2013.
25. F. Zafari. "Ibeacon Based Proximity and Indoor Localization System". Master's Thesis, Purdue University, USA, 2016.
26. B. G. Lee and S. Choi. "*Broadband Wireless Access and Local Networks: Mobile WiMAX and Wi-Fi*". USA: Artech House Publisher, 2008.
27. iBeacon. Available from: https://www.decawave.com/sites/default/files/resources/aps003_dw1000_rtls_introduction.pdf. [Last accessed on 2017 Dec 11].
28. S. Holm. "Hybrid Ultrasound-RFID Indoor Positioning: Combining the Best of Both Worlds". *IEEE International Conference*, 2009, pp. 155-162.
29. Decawave. "Real Time-Location: An Introduction". Available from: <https://www.developer.apple.com/ibeacon>. [Last accessed on 2016 Nov 01].
30. F. Ijaz, H. K. Yang, A. W. Ahmad and C. Lee. "Indoor Positioning: A Review of Indoor Ultrasonic Positioning Systems". *15th International Conference on, IEEE*, 2013, pp. 1146-1150.
31. N. B. Priyantha, A. Chakraborty and H. Balakrishnan. "The Cricket Location-support System". In *Proceedings of the 6th Annual International Conference on Mobile Computing and Networking*, 2000, pp. 32-43.
32. P. Babu. "10 Airports Using Beacons to Take Passenger Experience to the Next Level". Available from: <http://www.blog.beaconstac.com/2016/03>. [Last accessed on 2016 Oct 08].
33. Intel. "Wireless LAN Standards Study". Available from: <http://www.intel.com/content/dam/www/public/us/en/documents/case-studies/802-11-wireless-lan-standards-study.pdf>. [Last accessed 2016 Nov 02].
34. M. Shaik. "Ultra Wide-Band vs. Wi-Fi A Study and Comparison of the two Technologies". Available from: <http://www.academia.edu/4810093/Ultra>. [Last accessed on 2016 Nov 03].

Author Query???

AQ1: Kindly cite Figure 1-4 in text part (Example like as table 1 and table 2)