

We are IntechOpen, the world's leading publisher of Open Access books Built by scientists, for scientists

4,800

Open access books available

122,000

International authors and editors

135M

Downloads

Our authors are among the

154

Countries delivered to

TOP 1%

most cited scientists

12.2%

Contributors from top 500 universities



WEB OF SCIENCE™

Selection of our books indexed in the Book Citation Index
in Web of Science™ Core Collection (BKCI)

Interested in publishing with us?
Contact book.department@intechopen.com

Numbers displayed above are based on latest data collected.
For more information visit www.intechopen.com



Parametric Modeling of Machine Tools

Oleg Krol

Abstract

The chapter deals with the problems of machine tool computer-aided design (CAD) based on the methods and means of parameterization for the main components of metal-cutting machine and equipment in the CAD “APM WinMachine” environment. The models and algorithms of parametric modeling for the configurations of machine tool milling and multioperational type by the criteria of maximum rigidity and minimum reduced load on the front spindle support are developed. The express procedure for generating the transverse layout of the main drive in the multivariate design mode has been implemented.

Keywords: spatial gearbox configuration, transverse layout, multioperational machine, parameterization, 3D model

1. Introduction

Modern computer-aided design (CAD) constructive and technological purposes are widely used methods and means of parameterization to increase productivity, on the one hand, and improve the quality of design decisions made, on the other hand. In the modern “medium-” and “heavy-” class systems, the presence of a parametric model is embedded in the ideology of the CAD systems themselves. The existence of a parametric description of an object is the basis for the entire design process [1].

The process of parametric modeling is associated with the use of model element parameters and the relationships between these parameters, which makes it possible to effectively generate various versions of designed objects using variation of parameters or geometric relations. Unlike traditional 2D and 3D constructions, the use of parameterization tools allows to create a mathematical model of a structure with parameters that, when changed, leads to change the configuration of the structure, relative positions of the parts in the assembly, etc.

One of the designer priorities is to create a conceptual design of the future product and the initial linking of structural elements. Parameterization is a very valuable tool, which allows for a short time to analyze various design schemes and avoid fundamental errors.

Parametric technology corporation (PTC) is considered the pioneer of parameterization, which in 1988 was the first to implement a procedure for creating parametric models.

As is known, the design of machines and tools is primarily associated with the determination of the geometric shapes of detail and their relative position. Therefore, the history of automation is interconnected with the history of computer

graphics. Software automation systems had to be invariant with respect to a set of computing tools and equipment input and output of graphic information. This has led to the emergence of various standardization systems. Thus, the standard for the basic graphic system consists of a functional description and specification of graphic functions for various programming languages.

In the field of design automation, the unification of the geometric modeling basic operations gave rise to invariant geometric cores intended for use in various CAD systems. As known, the core includes a library of CAD system basic mathematical functions, which defines and stores 3D forms, processes commands, saves results, and outputs the results of processing. The most widely used are two geometric cores: Parasolid (a product of Unigraphics Solutions) and ACIS (Spatial Technology). The Parasolid core, developed in 1988, becomes the core of solid modeling for CAD/CAM Unigraphics and, since 1996, the industry standard.

Parasolid V19.1 is the first version with support for 64-bit operating systems, using the full power of 64-bit technology to increase the productivity of the creative design process, creating a single 3D modeling platform for the entire product lifecycle management (PLM) industry.

Using the powerful Parasolid core in such well-known CAD Unigraphics allows solving all problems not in external applications, such as in CATIA, where parameterization is performed at the external module level, but at the core level and all its applications working the same way inside the system.

This in-system approach enables the provision of the entire product creation cycle: from the conceptual idea to the implementation within the system itself, without the additional use of external applications. It is also important that providing a unified environment for product development allows you to create a single digital model with which all project participants can work simultaneously. In this case, it is necessary to have sufficiently powerful means of parameterization, allowing for changes of complex structures in large assemblies, to be able to build complex associative links and also certain flexibility, since the product is constantly changing in the design process.

However, in almost all systems, such as Autodesk Mechanical Desktop, Unigraphics, CATIA, I-DEAS, etc., one parameterize of the British company D-CUBED is used. The D-CUBED parameterize includes two components: a sketcher designed to build a parametric profile, on the basis of which a 3D operation will be created, and a mathematical library that allows to link individual parts into assembly structures.

The D-CUBED parameterize, focused on 3D modeling, is ineffective in 2D drawing. The mathematics that successfully works on dozens of profile lines in the 3D system sketcher does not cope with thousands of interrelated elements of drawings. And the need for a complete dimensioning of the D-CUBED parametric model turns the process of parameterization of even a simple drawing into an almost unreal task.

One very useful use of parameterization is the creation of standard element libraries. The cost of creating a parameterization scheme pays off by reusing libraries. So, in the KOMPAS system of the company ASCON [2–5], a simpler approach to the creation of libraries of standard elements has been successfully implemented. It consists in the rejection of the expensive borrowed parameterize and the use of proprietary software for programming a large number of standard elements in plug-in libraries and the transfer to third-party companies of the means for creating such libraries. This allowed the use of an inexpensive software product for obtaining a large set of parameterized libraries.

The process of computer-aided design is constantly being improved. An example of an innovative approach in the field of CAD is the emergence of synchronous modeling (CT) tools proposed by Siemens PLM Software. CAD NX is the flagship CAD/CAM/CAE PLM system (formerly Unigraphics) [6, 7].

This technology allows two main approaches to modeling: parametric design and direct editing. Thanks to synchronous technology, the possibilities of defining the functions of structural elements are expanded, which does not require the description of elements and their limitations manually. New methods for selecting objects automatically recognize logical and intra-element relationships even on models imported from other CAD systems, which contributes to the reuse of design data. For the first time, solutions are proposed for element-wise direct editing without a construction history, which is now available in NX.

CT technology allows setting fixed dimensions and parameters and designing rules at the time of creating or editing a model, without using the history of its creation. Synchronous modeling technology simultaneously synchronizes geometry and design rules by applying a new decision-making mechanism based on an expert system. It allows designers to use geometry from other CAD systems without creating it again. The suggestive selection technology automatically determines the functions of structural elements, without requiring manual description of the elements and their limitations.

Consider the main features of the use of the parameterization toolkit in the APM WinMachine CAD system [8]. In the mode of creating a parametric model, the drawing or any part of it is drawn by creating a special parametric model. The parameters have a numerical expression in drawing units, and their set will determine the dimensional characteristics of the particular part. Parameters are set either numerically or through analytical expressions, and the drawing law is a sequence of drawing commands and their corresponding logical and analytical expressions with the specified parameters. The parametric model created in this way can be inserted into a regular drawing as a parametric unit.

2. Parametric modeling of transverse layout for metal-cutting machine tools

2.1 Build optimal layout

The requirements for the design of specific machine tools vary depending on their types, while the construction of the basic layout is one of the most decisive steps. The layout of the machine is predetermined by the layout of the gearbox and the carrier system of the machine. The design of gearboxes for machine tools (main drive, feed box) is aimed at achieving a large range of rotational speeds (regulation range R_n of modern machines can reach $R_n = 100 \dots 250$) and high rigidity.

When designing speed boxes (SB), they seek to simplify the design and make it more compact by reducing the number of stages and limiting the gear ratios. So, the reduction of the radial dimensions can be carried out [9–11]:

1. The replacement of the three-shaft box to double-shaft.
2. Rational distribution of gear ratios between several pairs of wheels.
3. Use of parallel transmissions, so that the power is transmitted over the parallel streams and the size of the SB is significantly reduced.
4. Coaxial-mounted shafts, etc.

The use of CAD at various stages of designing assemblies of units and components of the machine involves the integration of a set of design and graphics modules, united by a single design concept with the ability to access common databases [12].

For the whole variety of machines of a certain group (type), it is impossible to use one or two SB structures. Most often, one has to either develop a new design using structural optimization methods or create a new version of the already known prototype design using the parametric optimization method. The parametric model is a sequence of drawing commands with the specified parameters. Parameters are set either numerically or through mathematical expressions.

A feature of the automated design process of a SB is a variety of alternative layout options and the need for adjustments and refinements to the specific features of the design object. The efficiency of the SB design depends on the adopted transverse layout (convolution), including the position of the output shaft. In the existing works on the design of the SB convolutions, the methodology and algorithm for constructing an effective variant of the box design according to the criteria of rigidity and reliability are not given.

In turn, the position of the output shaft in the optimal layout also depends on the position of the resultant cutting force R . Thus, for the range of milling and multioperational machine in the cutting process, tangential P_z and radial P_y components of cutting forces R arise [13–15].

When determining the spatial position of gears that transmit torque to the machine spindle, it is necessary to consider two mutually exclusive situations:

1. Parallelism and unidirectionality of the cutting force R and the resultant force Q in gearing “output shaft spindle” provide the maximum rigidity of the spindle assembly (minimum deflection of the spindle front end). This option is used in machines for finishing processing methods.
2. Parallelism and directivity in opposite directions of the forces R and Q provide the least load on the front support (as the most loaded during the machine operation). In this case, the deflection of the front end of the shaft is maximum, which is permissible only for roughing.

The many options for the SB parts design their mutual arrangement, on the one hand, as well as the need to increase the productivity of the designer, on the other, make it possible to use a parametric modeling apparatus. It is this mechanism that allows reducing the development time of a new or modification of known structures, implemented in all modern CAD systems [15–17].

The parameterization mechanism is characterized by the presence of interconnections and constraints between the geometric objects that make up this structure (as opposed to nonparametric). At the same time, a part of the indicated interrelations and restrictions can be formed automatically when entering graphic information and the rest can be assigned by the user independently.

2.2 Research problem statement

In this chapter, a procedure for constructing parametric models of gearbox transverse layouts for machine tools has been developed. The solved problem is formulated as follows:

To develop such a parametric model of the transverse assembly of the SB, which in one variant will provide the maximum rigidity of the designed machine (its spindle assembly), and in another variant, the minimum reduced load on the front spindle support.

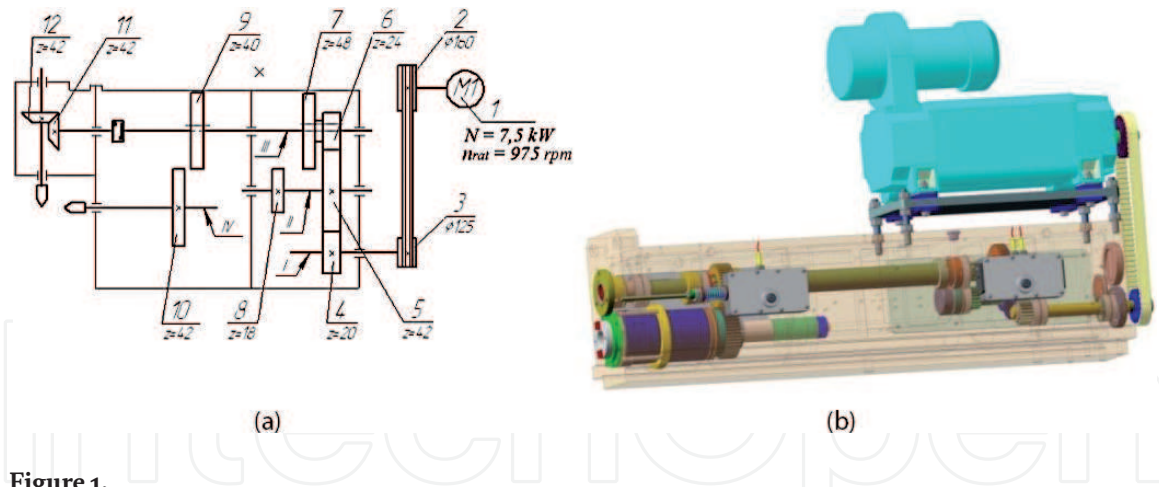

Figure 1. Spindle head of the DMB machine with SB: (a) kinematic diagram and (b) 3D model.

2.3 Parametric modeling of the speed box transverse layout for the drilling-milling and boring machine

As a prototype, we choose a horizontal drilling-milling boring machine (DMB machine) with advanced technological capabilities of the model SF68PF4 [18]. The layout of this machine involves moving along the horizontal guides of the headstock (Z axis), to which a vertical head is attached (**Figure 1a**) or additional devices (slotting and angle heads, trunk with a package of disk cutters).

The headstock includes a spindle unit with a tool clamping mechanism and a camshaft transmitting rotation to a horizontal or vertical spindle using an automatic gear shifter. A two-stage gearbox is built into the structure under consideration, as well as a number of other parts and assemblies that ensure the normal operation of the headstock. Rotation from the electric motor through the poly-V-belt is transmitted to the input shaft and through gearing to the camshaft of the gearbox. From the latter, rotation is transmitted to the coupling of the vertical head or to the gear of the horizontal spindle (**Figure 1a**). The 3D model of the DMB machine headstock was developed in the environment of the integrated CAD system KOMPAS-3D (**Figure 1b**) using the specialized application “shafts and mechanical transmissions 3D.”

2.4 Optimal layout options

The transverse convolution of the machine during the boring operation, taking into account the location of the cutting forces (P_z, P_y) and the forces in the gearing (P_0, P_r), is shown in **Figure 2**.

Analysis of the transverse arrangement shows the nonoptimal spatial position of the machine tool output shaft (n_v) relative to the spindle (n_{sp}), caused by non-parallelism of the resulting forces P and R . This leads to an increase in the reduced load on the front spindle bearing [19] and lowering its carrying capacity. However, this spatial arrangement simplifies the design of the gearbox housing, which is shown in **Figure 3**. In **Figure 3b** presents a three-dimensional model of mechanical gears that implement kinematic connections from an electric motor to a spindle unit. A three-dimensional model of the housing part has also been developed to provide the selected criterion for minimizing the reduced load on the front spindle support.

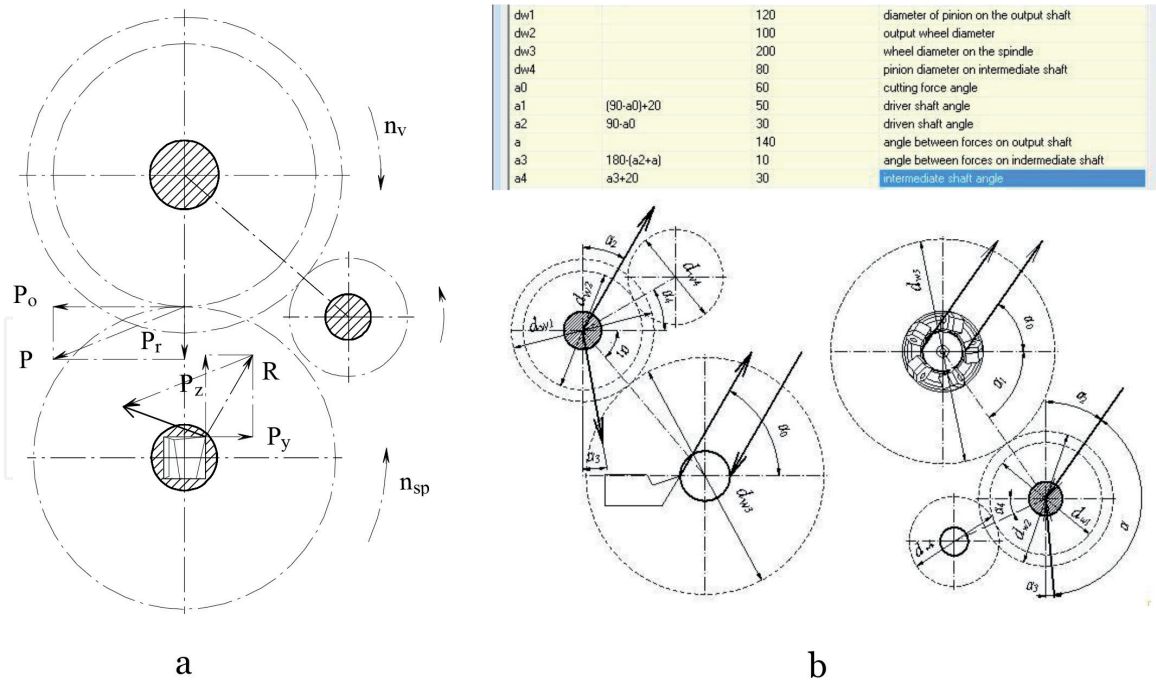

Figure 2. Transverse layout of the speed box for the machine model SF68VF4: (a) system of forces; and (b) fragment of the optimal layout parametric model.

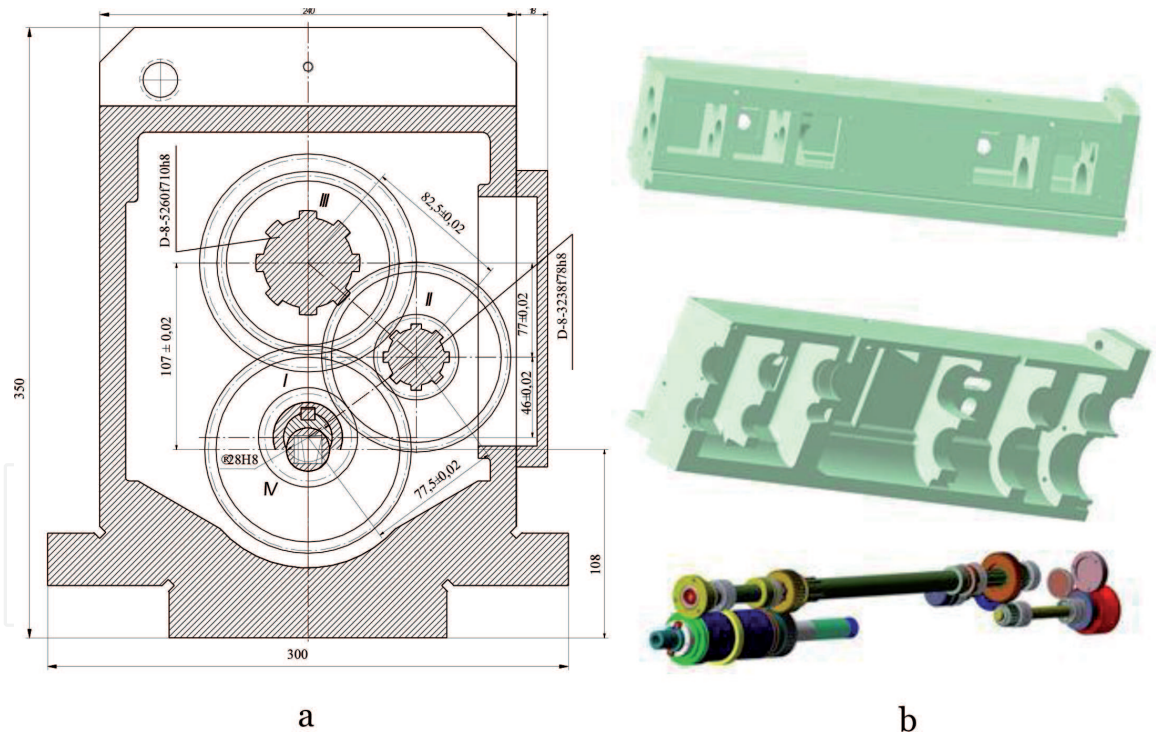

Figure 3. Speed box of the SF68VF4 machine (transverse layout): (a) design; and (b) housing and kinematics—3D gears.

Rather simple design of the housing differs in two original solutions:

1. On the right side of the housing, there is a joint for mounting the gear in a spatial layout. At the same time, the overall technologically feasible rectangular housing shape with minimal dimensions is maintained.
2. In the lower part of the housing, a spherical shape is deepened, which allows minimizing the size of the housing with fixed initial data.

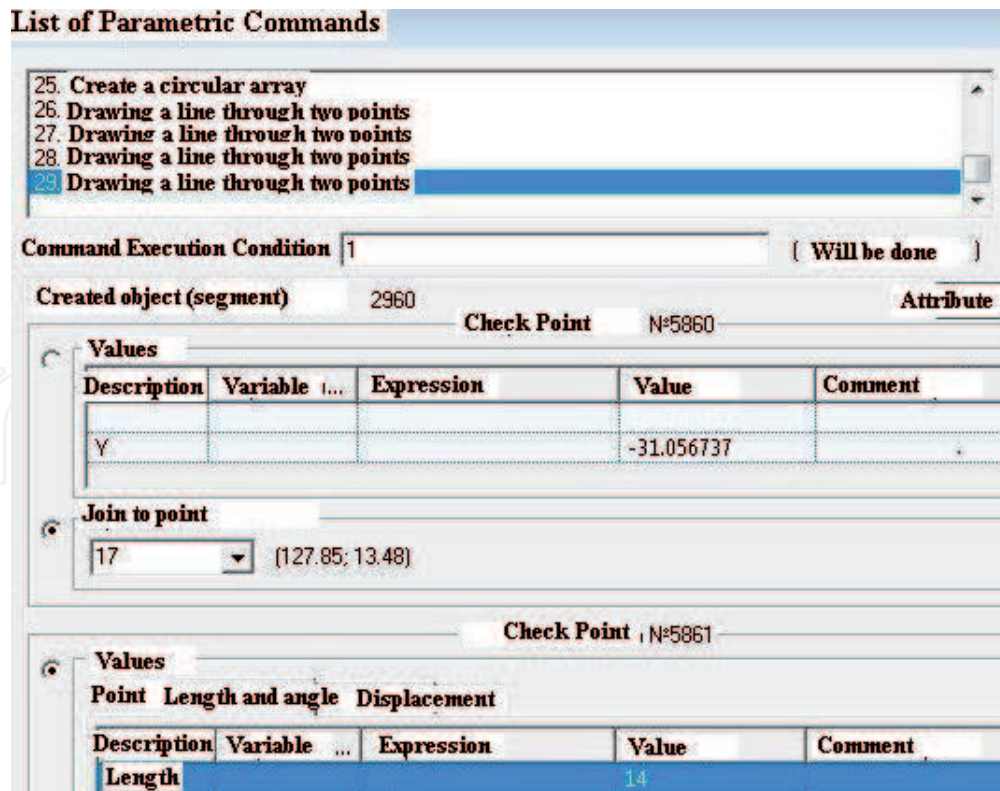

Figure 4.
The command window of the APM graph module.

The presence of the bottom of the nonrectilinear housing is an interesting version for the gearbox of a multifunctional machine. This design allows to implement such a spatial position of the shafts and the spindle, which ensures maximum rigidity of the spindle node and the machine tool as a whole.

At the stage of preliminary design, it is efficient to use a parameterization apparatus, with the help of which it is possible to solve the two-criterion problem of constructing the transverse layout of a horizontal headstock with an integrated two-staged gearbox. For this, we will use the parametric capabilities of the CAD/CAE system of the APM WinMachine system [11, 20].

2.5 Parameterization in the APM graph module

In this system (in the mode of creating a parametric model) is a design of a drawing (or any part of it); a special parametric model is formed. In this case, the APM Graph module is used, where a sequence of drawing commands and their corresponding logical and analytical expressions with the specified parameters are implemented. In **Figure 4** the command window is presented in the task of constructing a transverse layout (e.g., of constructing a “segment through two points”).

A parametric model created in this way can be inserted into a regular drawing as a parametric block.

The algorithm for working with the parametric model includes:

- Creation of a parametric model at the command level, which consists in linking graphical objects to those numerical data or communication equations that were set as variables. In this case, auxiliary variables can be used as input in the parameters of subsequent commands.
- Indication of the primitive type being created and its index in commands for creating graphic primitives. Indexes are used in those commands for the

execution of which. It is necessary to indicate one or more objects existing in the drawing (drawing a line parallel to the specified one, deleting objects, etc.).

- Editing the list of commands, consisting in the ability to remove a command from the list and replace it with another. Accordingly, the type of the parametric model may change, or errors due that together with the deleted command may appear. In this case any data necessary in subsequent commands was deleted.

The control points created with the object are also automatically indexed and can be used. In subsequent commands to directly access the created control points for the parametric model.

The designer has the ability to insert a parametric block into the drawing with a change in any of its parameters, including changing the scale and angle of inserted block rotation. The graphic part of the APM WinMachine system unified database [20] is similarly organized. It stores not only the numerical parameters of standard parts and elements but also their parametric models.

When inserting a graphical object from the database, the user has the opportunity not only to insert any standard element into the drawing, but also to change any of its parameters.

At the same time, to achieve the minimum load on the front spindle support, **Figure 5b**, it is necessary to adjust the housing design, while the housing connector should be made from the opposite side (**Figure 5a**).

Let us consider the basic design of the control gear for the wide-universal drilling-milling and boring machine with CNC model SF68PF4 [11], built into the two-stage SB of the main movement (**Figure 1**). In the mode of coordination with the rotary table, it provides processing of parts from all sides, as well as coaxial boring of holes without remounting the workpieces. The developed 3D model of

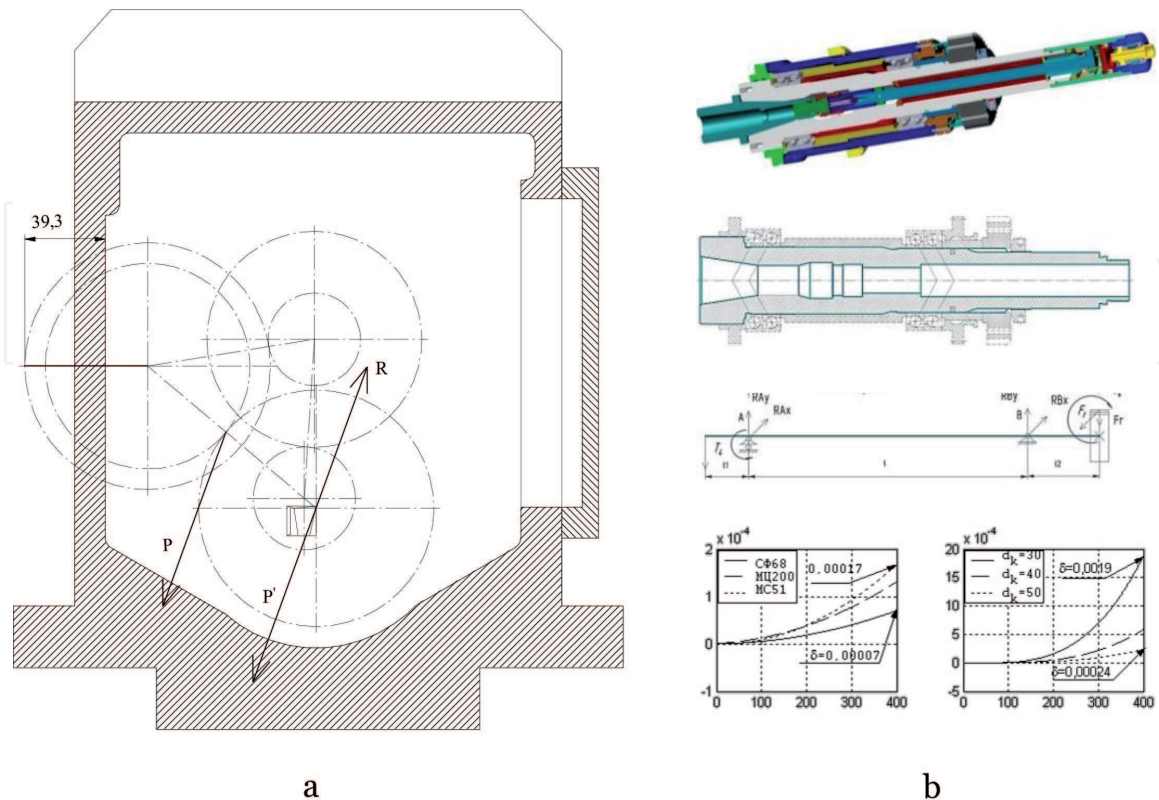

Figure 5. Transverse layout with the minimum reduced power: (a) design; and (b) study of the spindle stiffness characteristics.

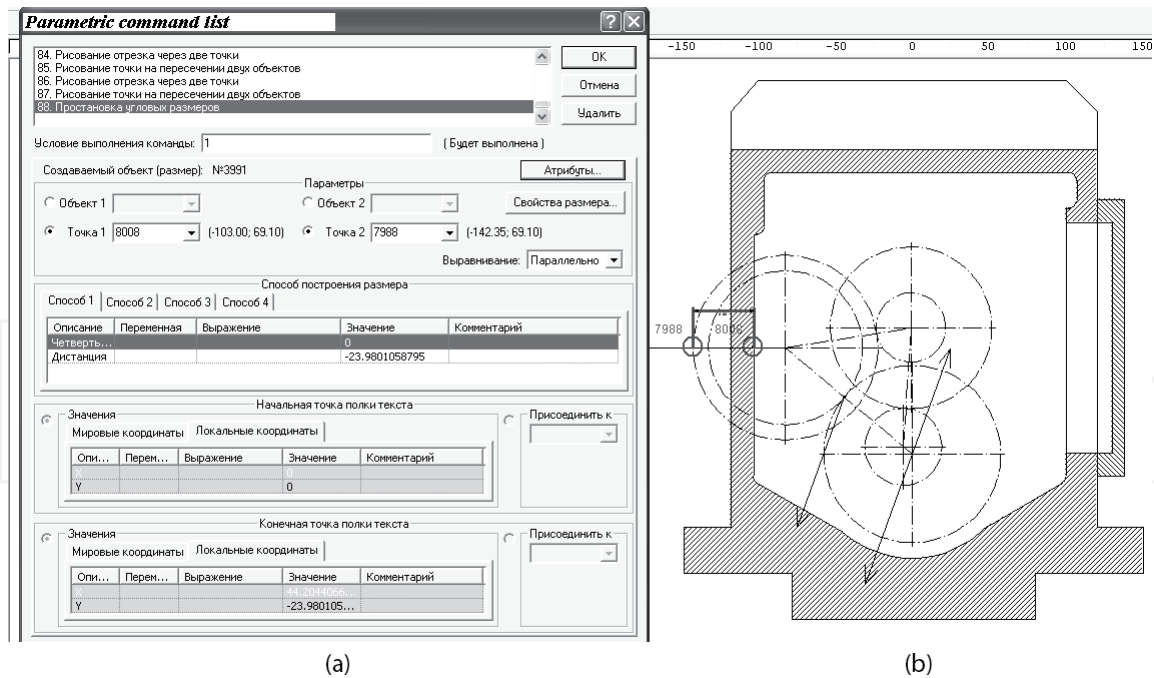

Figure 6. Command window of transverse layout parametric modeling: (a) command window; and (b) housing variant with minimum driving force.

the SF68PF4 machine spindle node (SN) using KOMPAS-3D resources for setting parametric connections and associations between the individual components of the 3D assembly is shown in **Figure 5b**.

The SN of this multioperational machine is considered as a beam on two elastic bearings, each of which is mounted on dual angular contact bearings installed according to the “Tandem-O” scheme with preload in the form of different-height bushings. The authors developed a 3D model of SN assembling with a mechanism for automatic tool clamping in the KOMPAS-3D system (**Figure 5b**).

To perform a comprehensive engineering analysis of both individual parts and assemblies, we will use the entire FEM module [19]. This module is equipped with a CAE library that implements solving engineering problems by the finite element method (FEM). In the process of solving, fixations and applied loads are set; matching faces are set (for FEM analysis of the assembly); FEM-mesh generation; calculation and viewing of results in the form of stress and displacement maps are performed.

To study the stiffness, an elastic-deformation model of spindle node two-support construction is built. It takes into account a set of modular equipment (consoles) of various sizes. A feature of the studied object is the presence of two components:

- Unified two-support spindle unit, which can be used in various multioperational machines.
- Tool blocks—a variable component, oriented to a different range of manufactured products.

Using the APM FEM module, all of the above actions were performed, and displacement fields on the set of spindle sections as beams were obtained. The analysis of the compliance characteristics for various multi-operation machines MTs 200PF4, MS51PF3, and SF68PF4 showed that the spindle assembly of the machine SF68PF4 is characterized by minimal flexibility. It has become possible due to the adoption of the optimal spatial layout. A study was made of the change

in the flexibility of the SN cantilever part for various standard sizes of tooling: with a spindle cone 30 AT5 in accordance with GOST 15945-82 for the model MS51PF3, with a cone 40 according to GOST 936-82 for model SF68PF4 and a cone 40AT5 according to GOST 15945-82 for model MTs200PF4V (Figure 5b).

To assess the change in the position of the gearbox shafts, a parametric modeling program was developed in the APM Graph (Figure 6).

Below is an example of a “message variable” (Figure 7), which is visualized in the working window in case of violation of the limit values x and k . For example, “Distance between the bottom of the housing and the wheel surface should exceed 24 mm” [21, 22].

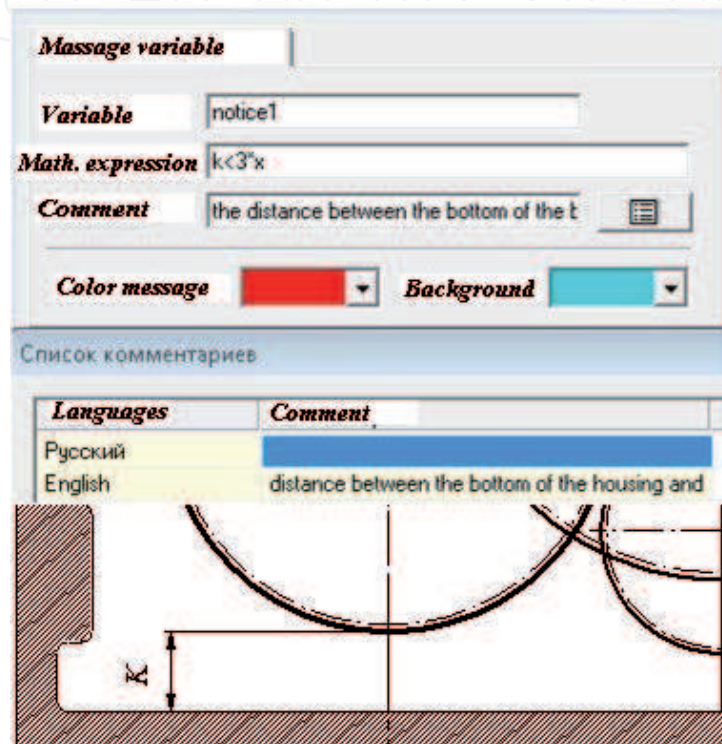

Figure 7.
“Variable-message”—unacceptable distance.

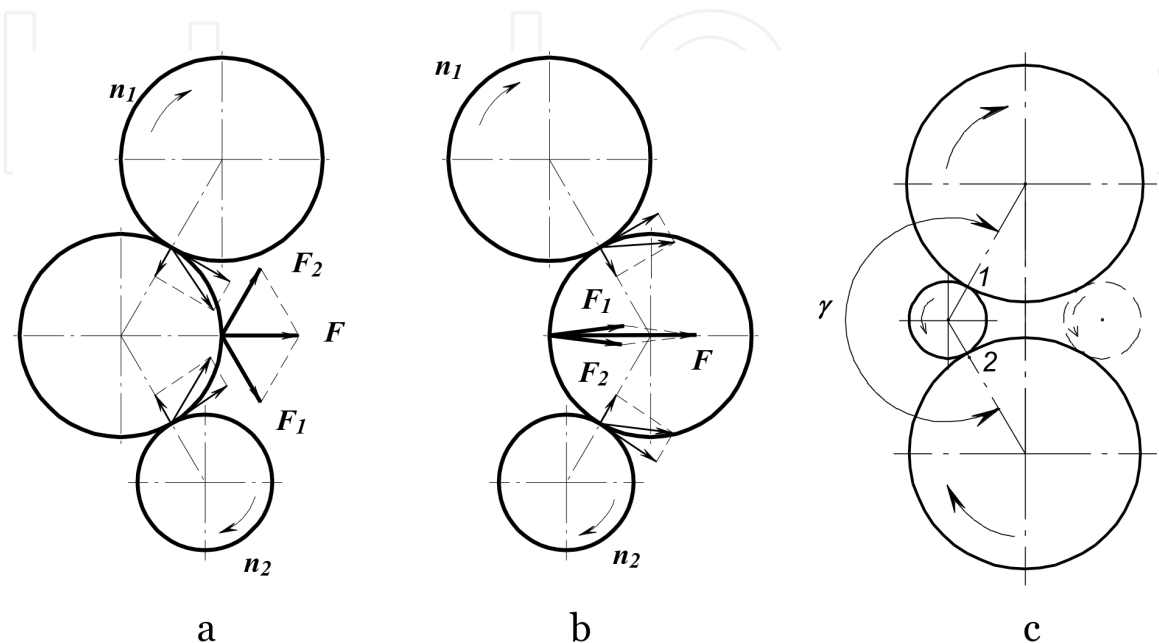

Figure 8.
Schemes of the influence of the intermediate links: (a and b) the intermediate gear; and (c) idle gear.

The arrangement of the wheels relative to each other affects the magnitude acting on the force transmission elements, so that the power characteristics can be improved. So, the location of the intermediate gear wheel (**Figure 8a, b**) affects the forces acting on the shaft bearings of this wheel.

In **Figure 8b**, the forces in the engagement F_1 and F_2 are almost parallel, and the total force F acting on the supports is large. In **Figure 8a**, due to a change in the direction of the forces F_1 and F_2 , they are largely compensated, and the resultant forces are less than in **Figure 8b**. It should be noted that for reversing transmission, it is preferable to arrange the axis of the wheels in the same plane.

Rational mounted of wheels [21] also affects the accuracy characteristics of kinematic chains. The error of the idle gear in the kinematic chain (**Figure 8c**) can influence itself in the error of the output link by a magnification doubled. The location of the idle gear for a given direction of rotation also influences. In the diagram (**Figure 8c**), the dashed line shows the best (from the standpoint of accuracy) mounting scheme of the idle gear for a given direction of rotation [23].

The general rule of mounting requires that the transfer of rotation on the idle gear takes place at the minimum angle γ between points of contact 1 and 2. When reversing the transmission of the axis, it is desirable to place on one line, as in the previous review (**Figure 7**).

3. Conclusion

The introduction of parameterization mechanisms in the traditional design process makes the work of the designer as efficient as possible. At the same time, the improvement of the project decision-making process takes place in the following directions:

1. The use of the developed parameterization mechanism significantly increases the efficiency of the metal-cutting machine tool study at various steps of design through the use of parametric models. This approach opens up the possibility of transition to solving complex project problems of a multi-criteria nature.
2. The introduction of the parameterization mechanism contributes to the formulation and solution of designing machine tool problems and their components in the multivariate mode. This significantly increases the level of design decisions made both at the design stage of individual parts and their assembly.
3. A significant effect in increasing designer productivity is the ability to quickly solve the problems of the design process with recurrent information flows (reengineering), when a set of parametric models implements an effective approximation to the best design option.
4. The correctness of the results obtained is due to the use of a wide regulatory base (GOST, departmental normal) in the process of developing parametric models.
5. In the process of parametric modeling, it is possible to introduce into consideration a wide range of parts of a certain class, which reduces the set of necessary models for the design tasks of machine tools and makes more visible the size of the CAD databases of machines.

Based on the proposed methods and parametrization facility, the following results were achieved:

1. Developed parametric models of transverse configurations (layout) of machine tools representative of the turning and milling groups. With the help of these models, built in accordance with the APM WinMachine syntax, it is possible to synthesize optimal transverse layouts both by the criterion of maximum rigidity and the criterion of the minimum load on the front spindle bearing.
2. Using the proposed algorithms for determining the spatial position of nodes in the main motion drive housing, it is possible to determine the distances from the external surfaces of gear wheels to the side walls and the bottom of the housing, as well as to estimate the degree of their approximation to the limit values. This will provide recommendations for reducing the size of the machine drives. On the other hand, the presence of a friendly interface in the APM Graph module promptly provides information to the designer about the unacceptable values of the gaps for rotating parts and the gearbox housing.
3. Based on the developed parametric layout models, recommendations are made for the improvement of housing parts. So, in the design of the main drive housing for the multipurpose machine, it is proposed to change the configuration of the housing bottom in order to ensure optimal spindle stiffness. In the machine drilling, milling and boring group model SF68VF4 proposed to perform the joint of the housing side wall to achieve the optimal design of the spindle unit.
4. Using the integrative capabilities of CAD/CAE/PDM “APM WinMachine” allows the designer to quickly estimate the magnitude of the discrepancy between the optimal and traditional factory solutions. So, with the help of the shaft design module APM Shaft in this work, the difference in the spindle stiffness values for the factory and optimum variants is determined. In this case, the designer receives the calculation form for the main indicators of strength and rigidity.

Author details

Oleg Krol

Volodymyr Dahl East Ukrainian National University, Severodonetsk, Ukraine

*Address all correspondence to: krolos@i.ua

IntechOpen

© 2020 The Author(s). Licensee IntechOpen. This chapter is distributed under the terms of the Creative Commons Attribution License (<http://creativecommons.org/licenses/by/3.0>), which permits unrestricted use, distribution, and reproduction in any medium, provided the original work is properly cited. 

References

- [1] Lee K. Basics of CAD (CAD/CAM/CAE). Peter: Saint Petersburg; 2004. p. 560
- [2] Fomin EP. Using parametric capabilities of KOMPAS-3D. CAD and Graphics. 2007;**10**:70-74
- [3] Krol OS, Sokolov VI. 3D Modeling Of Machine Tools For Designers. Sofia: Prof. Marin Drinov Academy Publishing House of Bulgarian Academy of Sciences; 2018. p. 140. DOI: 10.7546/3d_momtfd.2018
- [4] Krol O, Sokolov V. Modeling of carrier system dynamics for metal-cutting machines. In: IEEE Proceedings 2018 International Russian Automation Conference (RusAutoCon); 9-16 September 2018. Sochi: IEEE; 2018. pp. 1-5. DOI: 10.1109/rusautocon.2018.8501799
- [5] Krol O, Sokolov V. Modelling of spindle nodes for machining centers. Journal of Physics: Conference Series. 2018;**1084**(012007):1-7. DOI: 10.1088/1742-6596/1084/1/012007
- [6] Ushakov D. Synchronous technology—A simulation revolution from siemens PLM software. CAD/CAM/CAE Observer. 2008;**4**(40):1-4
- [7] Kurland R. Solid edge with synchronous technology—A revolution in CAD. CAD and Graphics. 2008;**9**:80-83
- [8] Rozinsky S, Shanin D, Grigoriev S. Parametric capabilities of the graphic module APM graph of the APM WinMachine system. CAD and Graphics. 2001;**11**:37-40
- [9] Bushuev VV. Fundamentals of Designing Machine Tools. Stankin: Moscow; 1992. p. 520
- [10] Krol OS, Krol AA. Parametrization of the transverse layout of the main movement drive. Tools reliability and optimization technological systems. Collection of Scientific Papers. 2009;**24**:164-168
- [11] Krol OS, Shevchenko SV, Sokolov VI. Design of Metal-Cutting Tools in the Middle of APM WinMachine. Textbook. Lugansk: Publishing house of SNU; 2011. p. 388
- [12] Taratynov OV, Averyanov OI, Klepikov VV, et al. Design and Calculation of Metal-Cutting Machines on a Computer: Textbook for Universities. Moscow: Publishing house of MGIU; 2002. p. 384
- [13] Krol O, Sokolov V. Parametric modeling of gear cutting tools. In: Advances in Manufacturing II. Lecture Notes in Mechanical Engineering (Manufacturing 2019); 19-22 May 2019. Vol. 4. Poznan, Cham: Springer; 2019. pp. 3-11. DOI: 10.1007/978-3-030-16943-5_1
- [14] Krol O, Sokolov V. Parametric modeling of transverse layout for machine tool gearboxes II. In: Lecture Notes in Mechanical Engineering (Manufacturing 2019); 19-22 May 2019. Vol. 4. Poznan, Cham: Springer; 2019. pp. 122-130. DOI: 10.1007/978-3-030-16943-5_11
- [15] Krol O, Sokolov V. Parametric Modeling of Machine Tools for Designers. Sofia: Prof. Marin Drinov Academy Publishing House of Bulgarian Academy of Sciences; 2018. p. 112. DOI: 10.7546/PMMTD.2018
- [16] Cherpakov BI, Averyanov OI, Adoyan GA, et al. Engineering Encyclopedia. In: Cherpakov BI, editor. Metal-Cutting Machines and Woodworking Equipment. Vol. 4-7. Moscow: Machinery Engineering Publishing; 2002. p. 672

[17] Avramova TM, Bushuev VV, Gilova LY, et al. In: Bushuev VV, editor. Metal Cutting Machines. Vol. 1. Moscow: Machinery Engineering Publishing; 2012. p. 608

[18] Krol O, Sokolov V. 3D modelling of angular spindle's head for machining centre. Journal of Physics Conference Series. 2019;1278(012002):1-9. DOI: 10.1088/1742-6596/1278/1/012002

[19] Shevchenko S, Mukhovaty A, Krol O. Geometric aspects of modifications of tapered roller bearings. Procedia Engineering. 2016;150:1107-1112. DOI: 10.1016/j.proeng.2016.07.07.221

[20] Zamriy AA. Practical Training Course CAD/CAE APM WinMachine. Teaching Aid. Moscow: Publishing House of APM; 2007. p. 144

[21] Reshetov DN. Details of Machines. Moscow: Machinery Engineering Publishing; 1989. p. 496

[22] Shevchenko S, Muhovaty A, Krol O. Gear clutch with modified tooth profiles. Procedia Engineering. 2017;206:979-984. DOI: 10.1016/j.proeng.2017.10.581

[23] Reshetov DN, Gusenkov AP, Drozdov YN. Mechanical engineering, encyclopedia. In: Reshetov DN, editor. Machine Parts, Structural Strength, Friction, Wear, Lubrication. Vol. IV-1. Moscow: Machinery Engineering Publishing; 1995. p. 864