

We are IntechOpen, the world's leading publisher of Open Access books Built by scientists, for scientists

4,800

Open access books available

122,000

International authors and editors

135M

Downloads

Our authors are among the

154

Countries delivered to

TOP 1%

most cited scientists

12.2%

Contributors from top 500 universities



WEB OF SCIENCE™

Selection of our books indexed in the Book Citation Index
in Web of Science™ Core Collection (BKCI)

Interested in publishing with us?
Contact book.department@intechopen.com

Numbers displayed above are based on latest data collected.
For more information visit www.intechopen.com



Cognitive Radio-Modulation and Demodulation

Madhuri Gummineni and Trinatha Rao Polipalli

Abstract

The reconfigurability in Cognitive Radio (CR) facilitates to dynamically change its parameters for the efficient spectrum utilization. The motivation behind the study of cognitive radio is that the number of different radio signals can be handled without using extra circuitry, i.e., reusing identical hardware with the change in the software will reduce time to market, development cost, and upgrade infrastructure. Software Defined Radio (SDR) is an enabling technology for Cognitive Radio (CR); therefore, it emphasizes on SDR unique features, characteristics, and basics concepts that are required to understand operation of SDR. SDR allows service providers to upgrade infrastructure without unreasonable cost. Modulation techniques play a vital role in any communication systems such as cable modems, DSL modems, CDMA, 4G, Wi-Fi, and WIMAX; thus, it emphasizes on implementation of modulation techniques using SDR Generic hardware, which is operated by Open Source software called GNU Radio. Implementation of various analog and digital modulation techniques using the GNU Radio provides a way for developing advanced wireless communication system. GNU Radio software is a highly flexible signal processing platform, which makes it easy and reduces time to implement different modulation techniques with appropriate script.

Keywords: spectrum scarcity, spectrum management, cognitive radio, software defined radio (SDR), modulation

1. Introduction to cognitive radio

In advanced wireless communication systems, an intelligence of cognitive radio helps to become aware of the environment and internal state and can adapt itself for better performance. Cognitive Radio utilizes Software Defined Radio, Adaptive Radio, and other technologies to automatically adjust its behavior or operations to achieve desired objectives. A Cognitive Radio may adjust all the transmission characteristics from frequency to power level. Software defined radio (SDR) and artificial intelligence (AI) technology enables the field of cognitive radio. A Cognitive Radio is an extension of modern SDR [7]. There is need for cognitive radio in present 21st century due to following reasons.

- i. Generations and its impact on wireless traffic
- ii. Spectrum scarcity
- iii. Spectrum management

Generations	Standards	Technology-data rate	Applications
1G	AMPS, TACS	Analog-2.4 kbps	Only voice
2G (802.11a)	GSM, CDMA, EDGE, GPRS	Digital-64 kbps	SMS and voice
3G (802.11 g)	WCDMA, UTMS	Digital-144 kbps to 2Mbps	WAP, SMS and voice
4G (802.16e)	SEAMLESS MULTIMODE, LTE-A	Digital 802.16 (WiMax)- up to 1 Gbps	Online gaming, TV, Internet, video calls, WAP, SMS, and voice
5G (802.16 m)	Massive MIMO	WWWW-higher than 1 Gbps	High speed applications, mobile TV and wearable devices

Table 1.
Generations and its improvements in applications.

- i. **Generations and its impact on wireless Traffic:** Every generation have some standards, different capacities, new techniques and new features which differentiate it from the previous one. The complexity of functions, components and design rules of these architectures continues to increase with each generation, as shown in **Table 1**.

Initially wireless communication network was analog and used for voice calls only. Later digital technology supports text messaging, internet, whereas Fifth Generation Mobile technology is going to be a new revolution in mobile market which has changed the means to use cell phones within very high bandwidth.

These Applications demands high data rate, and create traffic congestion, that intern leads to create requirement for more complex communication standards and modulation techniques. It cannot be achieved with analog platform because analog have inherent fabrication errors. In particular, future seamless multi- mode networks will require radio terminals and base stations with agile, RF bands, channel access modes, data rates, power and functionality.

- ii. **Spectrum Scarcity:** The Rules and channel allocation are generally made by FCC. Because of heavy traffic and strict rules mobile users are allowed to use certain frequency only, which get crowded. Mobile frequencies are getting crowded with various applications like Music, Video on the Internet which intern requires more bandwidth.
- iii. **Need for Advanced Spectrum Management:** Spectrum is regulated by governmental agencies. Spectrum access is granted by the regulatory agencies to the primary users or licensed to them on a long term basis. Due to the allocation, resources are wasted because large-frequency regions are used very sporadically. The aim of spectrum management [11] is to assign suitable channel/frequency to the mobile users based on the required condition being aware of geographically bounded region, that may be, a personal, local, regional, or global cell. Hence, there is a need for intelligent device in order to use the whole radio spectrum in the most efficient way.

2. Benefits of cognitive radio

The following are the benefits of Cognitive Radio:

i. The base band section of a communication system can be implemented by software which is a unique platform provided by cognitive radio. The theoretical concepts can be verified through experimental observations which motivated to opt Software Defined Radio.

ii. Optimum use of spectrum, organize interoperability, reconfigure networks to meet current needs.

iii. A software radio terminal, for example, could operate in a GSM network, an AMPS network, and a future satellite mobile network. Software radios have emerged to increase quality of service through such agility. The SDR architecture overcomes all the tradeoffs of hardware radio and provides opportunity to customize the performance of the radio.

CR being the central unit, all the users can connect and communicate at the same time. CR can be compatible with any radio. This combined with simple radio embedded in any object would allow interaction with any physical object (Figure 1).

iv. Signal transmission and reception between Cognitive radio depends mainly on channel and power, and they will be dynamically changing for improving spectrum efficiency and This process is defined as dynamic spectrum management. The steps for dynamic spectrum Management are

- a. Identify the spectrum hole.
- b. Ensure that spectrum not being used by any users.
- c. Before establish the communication between Cognitive Radios find the common spectrum hole.
- d. During communication if it detects any user it should stop transmission and change to another spectrum hole.

Major challenges of DSM are the parameters of Radio which been changing due to environment and optimal channel assignment.

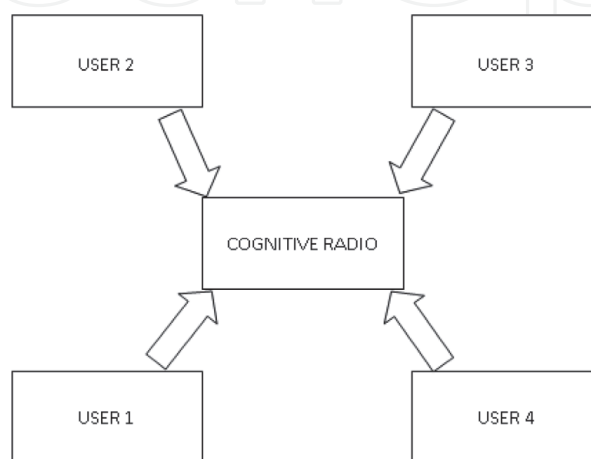

Figure 1.
Cognitive radio as central control unit.

3. Software defined radio (SDR)

The purpose of Radio is to transmit or receive electromagnetic radiation, whereas software facilitates modifiable instructions executed by a programmable processing device [1]. Software defined refers to the use of software for processing within the radio system or device to implement operating functions, in other words a large portion of functionality is implemented through programmable signal processing devices.

Software Defined Radio is a reconfigurable radios because physical layer behavior is mostly altered through software as well modulation waveforms and all wireless communication is controlled by the software. Therefore, this approach reduces the content of RF and other analog components of traditional radios and emphasizes on DSP to enhance overall receiver flexibility (**Figure 2**).

SDR have transformed electronic devices from transistor to software. SDR functionality is partitioned in to software and Hardware domain. The Software domain supports all Signal processing Tasks, whereas IQ samples are handled by Hardware. SDR requires a general purpose RF Front end, which consists of Pre-Selector/Power Amplifier, Receive/Transmit Chain, and Synthesizer.

Pre-Selector/Power Amplifier is required to select subset of spectrum. Receive/Transmit Chain is required to Process the radio signal in analog domain. Synthesizer is required to generate local oscillations for processing.

3.1 SDR overview

Software-defined radio is an integrated platform of software and hardware that enable to develop application based on the requirement in short span of time.

Hardware: HackRF One, Pico Zed SDR, USRP-B200, USRP-B210, BladeRF, UmTRX, Matchstiq, RTL2832U-RealtekSDR dongle,

Software: GNU Radio, Gr-OsmoSDR, SDR#, HSDR, Gqrx.

Front-End Issues of SDR:

1. HackRF One (Half-duplex)—supported by GNU Radio.
2. Pico Zed SDR -Supported by Matlab and Simulink.
3. USRP-B series (Full-duplex) -supported by GNU Radio.

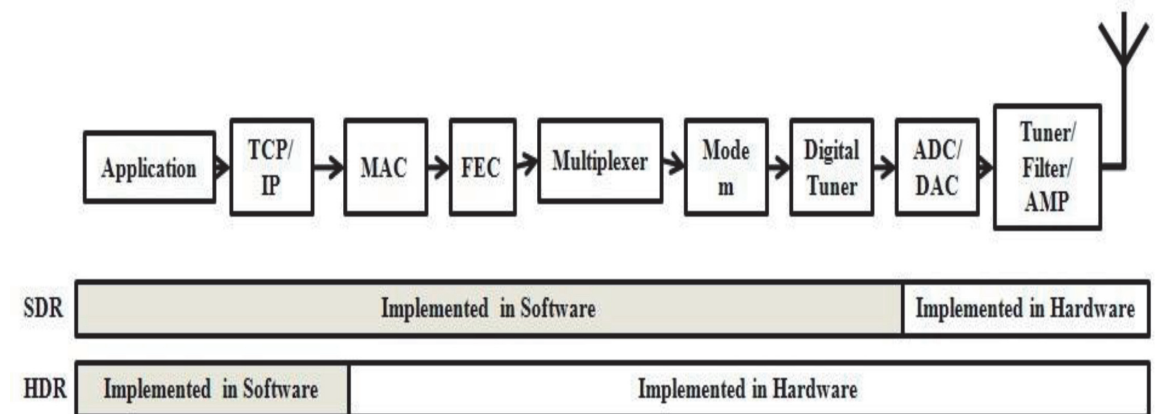

Figure 2. Depicts the Software Defined Radio and Hardware Defined Radio.

4. The BladeRF 2.0 micro features support: GNU Radio, Gr-OsmoSDR, SDR Sharp-BladeRF, MATLAB, and Simulink.

The hardware aspects of a platform consist of the Radio-Frequency (RF) elements, some baseband signal processing and communications link to the software based signal processing element—perhaps a DSP, FPGA, or a general purpose processor (GPP) (Figure 3).

According to functions performed by an SDR, it can be called to be:

- i. **Multiband system:** Multiband system reuse the locally unused spectrum and increase the total system capacity [19, 20]. For implementing multiband system CR will listen to the channel and, if the channel is free it will transmit. One of the application of this system is the transmission area is expanded by using multi-hop networks with multi-band channel. (e.g., GSM 900, GSM 1800, GSM 1900),
- ii. **A Multi standard system:** support more than one standard family (e.g., UTRA-FDD, UTRA-TDD for UMTS) or across different networks (e.g., DECT, GSM, UMTS, WLAN).
- iii. **Multiservice system:** By using Algorithms such as Greedy, Genetic, Multivariable, and Localized Algorithm [14–18] etc. for multi service channel allocation, it allows to provide services to video and data service simultaneously for frequency/time slotted cognitive radio (CR) networks.
- iv. **A Multichannel system** improves the throughput [13], and it can be implemented using CR, by detecting the multiple idle channels, and by using multichannel access modes such as OFDM and MC-CDMA, thus it covers the multiple channels during the absence of PU.

3.2 Functions of SDR transmitter and receiver

Software radio performs the above functions at the transmitter side and is shown in figure. It identifies the available transmission channels [5, 16], determines the suitable channel modulation, examines the propagation path, and steers its

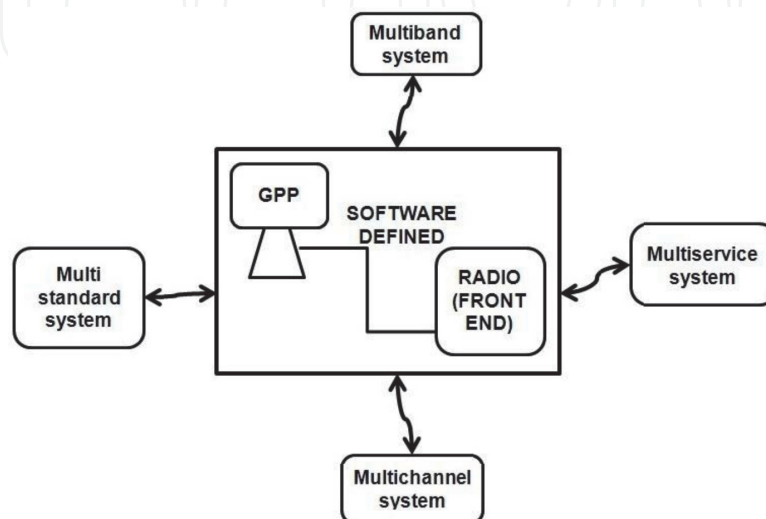

Figure 3.
SDR overview.

transmit beam in the right direction. And also, it determines the appropriate power level, and then transmits in an advanced application.

The following functions are performed at the receive side of SDR. It detects and compares the energy distribution in the channel and in adjacent channels, the mode of the incoming transmission is recognized, interference is nullified adaptively by the receiver. For multipath signal it estimates the dynamic properties for recovering the signal effectively, combines desired-signal from multipath coherently, adaptively equalizes, decodes the channel modulation, and then corrects residual errors via forward error control (FEC), it also decodes to receive a signal with lowest possible BER in an advanced application (**Figures 4 and 5**).

3.3 Architecture of SDR

The Antenna should possess the following characteristics for operation of SDR.

- i. It should be flexible to tune to several bands.
- ii. Interference rejection
- iii. Beam forming Capability (**Figure 6**).

RF Front End has two basic functions:

- i. TX/RX signal at various operating frequencies.
- ii. Change to/from IF.

The above two process [21] of operation is based on direction of TX/RX mode.

In transmission mode, digital samples are converted by DAC and then mixed with RF frequency and Modulated, then transmitted through Antenna.

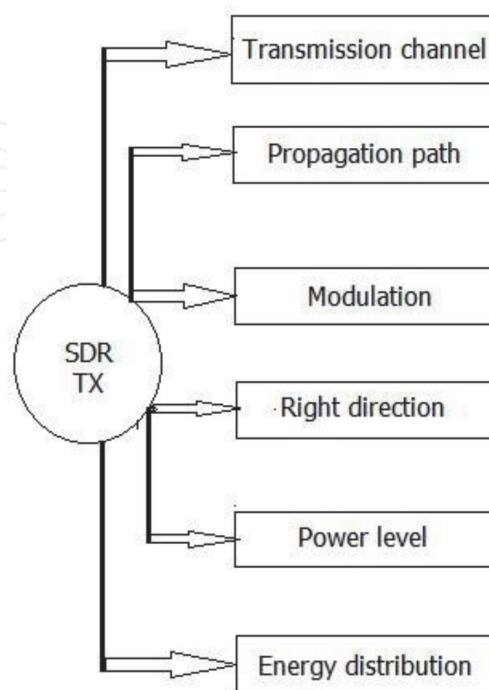

Figure 4.
SDR transmitter.

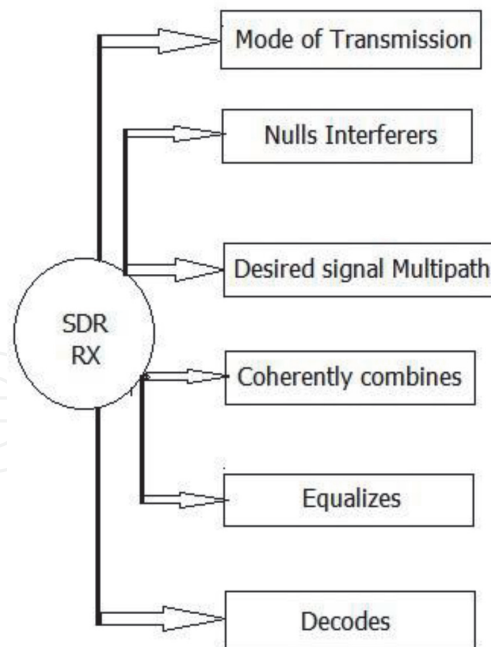

Figure 5.
SDR receiver.

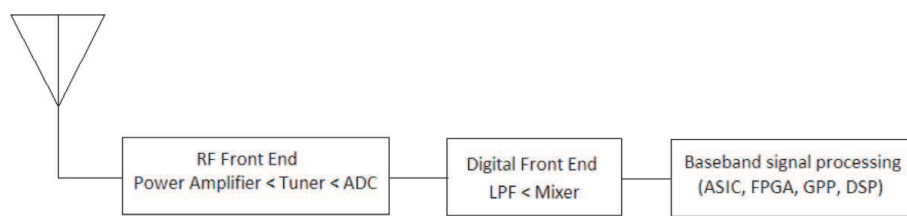

Figure 6.
Block diagram of SDR receiver.

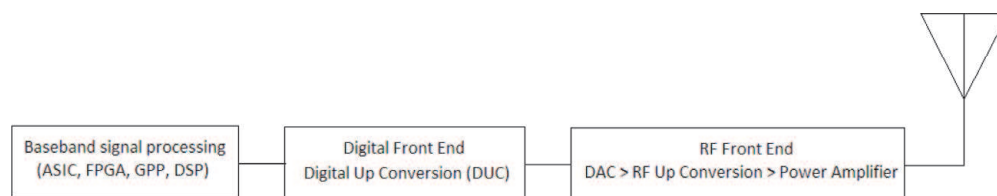

Figure 7.
Block diagram of SDR transmitter.

In receiving mode the antenna is connected to matching/selection circuitry, for reducing the noise it is passes through LNA then to mixer in order to down convert to IF (**Figure 7**).

Digital Front End: To synchronize the TX/RX part to Baseband part it requires conversion of sampling. The DUC in transmitter side translates Baseband signal to IF signal. On Receiver side, DDC which includes Mixer will extracts the baseband signal from ADC and forwards it to signal processing block.

3.4 Introduction to complex signals

In order to analyze and design digital communication systems, it is essential to understand the representation of a signal. A signal is composed of sum of its in-phase (I) and Quadrature (Q) components. The data input to the SDR is complex, which includes I and Q signals.

The Local sampling clock is used as the basic reference in Digital Signal Processing (DSP), therefore it relies heavily on I and Q signals for processing. If real signals (cosine) are shifted from modulated signal to baseband signal, we get sum and difference of frequencies. One key operation in signal processing is the shifting of a signal spectrum from one center-frequency to another. The basis of all the frequency translations lies in multiplying a signal with a complex exponential, generally referred to as complex or I/Q mixing.

3.4.1 Components of sine wave

Sinusoidal signals can be represented as time varying complex numbers Amplitude and Phase (Polar coordinates).

I and Q (rectangular coordinates).

I = In phase (real).

Q = Quadrature (imaginary).

The time domain waveform $x(t)$ of a complex signal is

$$X(t) = xi(t) + jxq(t) \quad (1)$$

$$V(t) = A \times \text{Sin}(2\pi ft + \varphi) \quad (2)$$

Where A is the Peak Voltage, f is the frequency, t is the time, is the phase shift.

The two signals when they are 90° apart in phase are said to Quadrature (1/4 cycles).

Ex: Cosine and Sine waves are in Quadrature.

The Amplitude of the In-phase signal I

$$I \times \cos(2\pi ft) \quad (3)$$

The Amplitude of the 90° shifted signal φ

$$\varphi \times \sin(2\pi ft) \quad (4)$$

While Adding the Quadrature Signal, when I and φ vary identically, the Amplitude of the Sum varies (**Figure 8**).

When I and φ vary differently, the phase of the Sum varies. Therefore, $I(t)$ and $\varphi(t)$ variation result in Amplitude, phase and Frequency modulation of the sum. $I(t)$ and $Q(t)$ signals can be generated to result in any modulation such as AM, FM, PM, SSB, BPSK, QPSK, 16QAM, etc. I and Q signals can be easily generated and analyzed in software and processed through ADC and DAC (**Figure 9**).

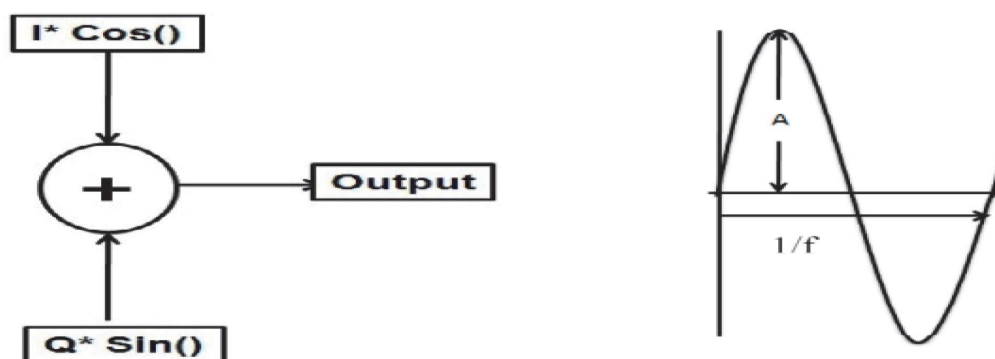

Figure 8.
I and Q signals and a sinusoidal signal.

Nyquist frequency is twice highest frequency of the signal. For example: in analog signal processing, most frequently used frequency is 455 kHz. It requires 910 Ks/s to sample in digital processing, if the signal bandwidth is only 10 kHz. Whereas I and Q, sampling requires only 20 Ks/s.

I and Q allow discriminating of positive and negative frequencies.

$$\text{If: } H(f) = a + jb \quad (5)$$

$$\text{Then: } H(-f) = a - jb \quad (6)$$

Representing the basic characteristics of a signal with I and Q:

$$\text{Amplitude } A(t) = \sqrt{I^2(t) + Q^2(t)} \quad (7)$$

$$\text{Phase } \phi(t) = \tan^{-1} \left[\frac{Q(t)}{I(t)} \right] \quad (8)$$

$$f(t) = \frac{\partial \phi(t)}{\partial t} = \frac{I(t) \frac{\partial Q(t)}{I(t)} - Q(t) \frac{\partial I(t)}{I(t)}}{I^2(t) + Q^2(t)} \quad (9)$$

The Traditional FM equation

$$x_{FM}(t) = \cos \left(\omega_c t + k \int x_m(t) dt \right) \quad (10)$$

The analytic equation

$$x_{FM}(t) = I(t) \cos(\omega_c t) + Q(t) \sin(\omega_c t) \quad (11)$$

Equations using with I and Q representation for Modulation Techniques.

$$\text{AM: } x(t) = \sqrt{i^2(t) + q^2(t)} \quad (12)$$

$$\text{SSB: } x(t) = i(t) \quad (13)$$

$$\text{FM: } x(t) = \frac{1}{\Delta t} = \tan^{-1} \left[\frac{i(t)q(t-1) + q(t)i(t-1)}{i(t)i(t-1) - q(t)q(t-1)} \right] \quad (14)$$

$$\text{PM: } x(t) = \tan^{-1} \left[\frac{q(t)}{i(t)} \right] \quad (15)$$

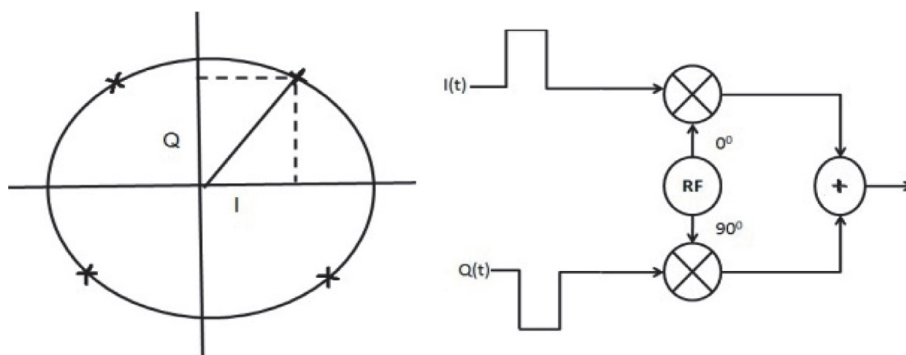

Figure 9.
 Phasor diagram and quadrature signal generator.

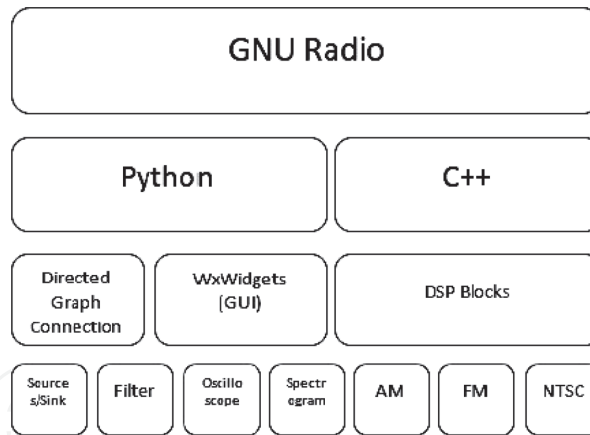

Figure 10.
Basic structure of GNU radio.

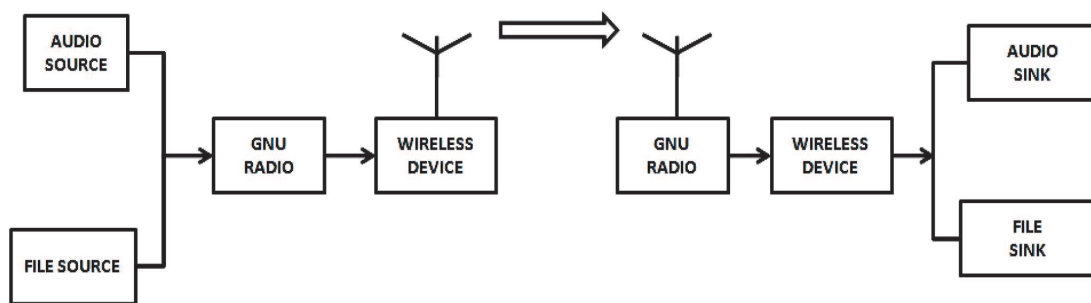

Figure 11.
GRC architecture for transmitter and receiver.

3.5 GNU radio

C++ and Python are the two major layers that are used in GNU Radio. For small signal processing task code are written in C++. The high level codes are written in Python used as an interpretable language, it mainly perform the work of connecting the various signal blocks to make a signal Flow graphs. Python does not require any additional compilation time so it is mainly used for the rapid functioning of the flow graph (**Figure 10**).

The GNU Radio software provides a set of signal processing blocks that can be aggregated to build flow-graphs shown in **Figures 10** and **11**. These blocks are written in C++ and run in Python, which brings several advantages, such as easy instantiation and connection of existing blocks and easy GUI (Graphical User Interface) creation, as shown in **Figure 10**, Around 250 blocks in GNU Radio include various applications like simple mathematical operation blocks, modulators/demodulator blocks, channel coding blocks, voice codec and others. Input/output blocks are the Special classes of blocks.

In this system, Host Computer is any normal Laptop/CPU with GNU Radio installed over it or running with the help of live USB environment is shown in **Figure 11**.

4. Signal processing blocks in GNU radio

It Consist of complex flow graph that includes modules and low level algorithm. The basic signal processing functions such as filters and channel coding are structured in C++ [10] called to be low level algorithm or module. With the interface of wrapper SWIG (i.e., Simplified Wrapper and Interface Generator) they are generated as python modules.

With the help of python, the generated blocks are used to construct a flow graph model shown in **Figure 12**. The application is built on python program that provides python framework. The python frame work creates a simple scheduler to run blocks in a sequential order for every iteration and it is responsible for communication of data through module buffers.

Signal Source: The head (start) of the flow-graph is the source. For instance, Osmocom Source, USRP source, and file source are common types of source blocks.

Signal Sink: Sink is used at the end of the flow-graph. For instance, USRP sink, file sink are common types of sink blocks.

Flow-graph: The application is based on a flow-graph. Each flow-graph consists of intermediate processing blocks along with single source and sink blocks. We can have multiple flow graphs within a single application.

Scheduler: It is created for each active flow-graph, which is based on steady stream of data flow [9] between the blocks. It is responsible for transferring data through the flow-graph. It monitors at the I/p and O/p buffers of each block for sufficient data so as to trigger processing function for those blocks.

Three important stages are observed in a basic Radio. They are Front End, IF stage and Demodulator stage. Similarly GRC flow graph consist of following blocks like Source, Sink Filter, and Demodulator/Modulator.

Front end stage or Source Block is required for radio, whose function is to tune frequency, sample rate, applying the RF gain etc. These three are essential after receiving the signal from Antenna. In GNU Radio this front end stage is provided by USRP Source block, Osmocom Source block and RTL-SDR source block.

Intermediate stage will fulfill the function called sample rate conversion. Which consist of steps like up-sampling (interpolation), down-sampling (decimation), Low pass filter, Band pass filter is used.

In **Demodulator stage** Appropriate Demodulator [3] (AM Demodulator, NBFM Receiver, and WBFM Receiver) is used to recover the signal. Sometimes amplifier is used to support the end device.

Graphical User Interface (GUI) in GNU Radio displays the signals, in Time/Frequency, scope to observe the waterfall, histogram scope, constellation scope for observing the digital modulation schemes. The following blocks called Chooser block, variable, notebook, slider to provide tuning, selecting the parameters.

Sampling rate conversion (SRC) [23, 24]: SRC must synchronize the Clock rate of ADC and baseband signal processor. Main reason of processing of sample rate conversion in reconfigurable radio by SDR software is to place the ADC as close as possible to antenna without changing underlying hardware, to emulate any signal of different frequencies.

Reconstruction after re-sampling process: let a signal at f_1 is to be converted to f_2 rate the popular method is to perform DAC and resample the reconstructed signal (**Figure 13**).

During resampling process spectral repetition is caused, in turn spectral overlap occurs which is called Aliasing. This can be avoided by reconstruction filter $h_c(t)$ to band limit the signal. To suppress aliasing and imaging effect the filters along Decimators and Interpolators are used respectively (**Figure 14**).

Decimation/Sample rate reduction: Anti-aliasing filter followed by down-sampling is known as decimation.



Figure 12.
Basic structure of GNU radio flow graph.

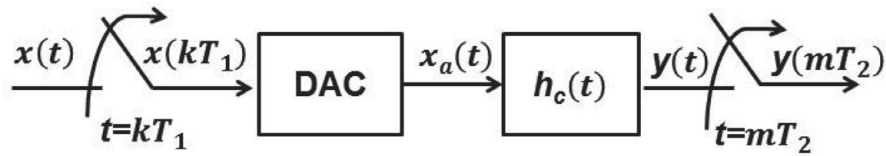

Figure 13.
Sampling rate conversion.

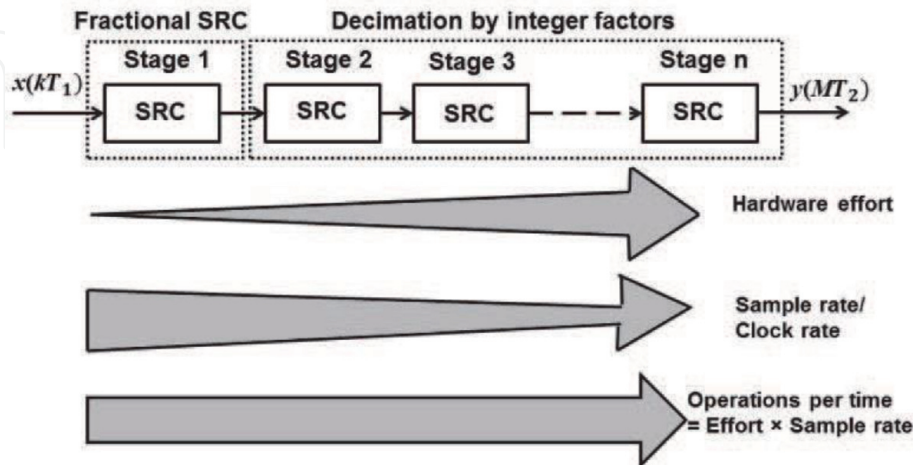

Figure 14.
Multistage SRC.

Interpolation/Sample rate increase: Up-sampler followed by anti-imaging filter (Interpolating Filter) is called Interpolation. The hardware effort increases as the sampling rate decreases from first stage to last stage in a multistage SRC system.

Rational factor SRC: when L/M both are positive integers to provide combined effect of reducing anti imaging and anti-aliasing it is called Rational Factor.

The benefit of using Multistage SRC is computational complexity is reduced and simplified filter design.

4.1 Analog modulation techniques

4.1.1 Amplitude modulation (AM)

A message or signal can modify a radio wave by changing its amplitude [4], phase or frequency. Amplitude modulation changes the amplitude of a radio wave in concert with changes in the message. Some real time examples such as Sound signal at the speaker end, or intensity of light for television pixels, etc. Implementation of Amplitude Modulation is shown in **Figure 15**.

The data flow graph has been designed by considering the following equations. The carrier wave of frequency f_c and amplitude A is given by:

$$c(t) = A \times \sin(2\pi f_c t) \quad (16)$$

where, $f_c = 10$ kHz and $A = 1$.

The modulation waveform of frequency f_m and amplitude M is given by:

$$m(t) = M \times \sin(2\pi f_m t) \quad (17)$$

where, $f_m = 1$ kHz and $M = 0.7$.

The amplitude-modulated wave is obtained by considering the following equation:

$$y(t) = [1 + m(t)] \times c(t) \quad (18)$$

4.1.2 Generation of AM using GNU radio

The following are the Requirements for implementation of AM:

The two Signal Sources are required one for Message and other for Carrier signal, and pass the signals through multiplier (product) to generate AM modulated signal (Figure 16).

At the receiver side there is need for Sample Rate Conversion due to the following reason:

Sampling-rate conversion can be accomplished by L-fold expansion, followed by low-pass filtering and then M-fold decimation. It is important to emphasize that the interpolation should be performed first and decimation second, to preserve the desired spectral characteristics of $x[n]$. Furthermore by cascading the two in this manner, both of the filters can be combined into one single low-pass filter. Demodulator is followed by the filter to recover the signal.

In GNU Radio all the modulation techniques are implemented in Software, and also by applying mathematical operations to streaming data for low pass digital filters, digitally generated Oscillators frequency Synthesis, signal processing algorithms are also implemented as software.

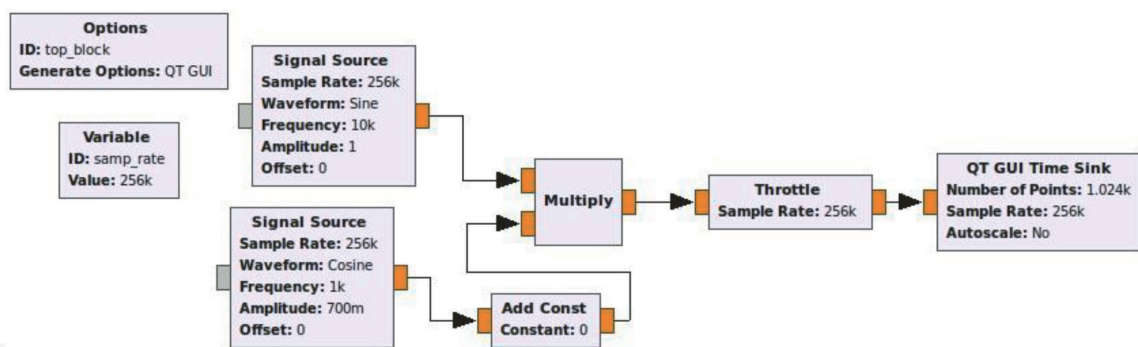

Figure 15.
 GRC flow graph for generating amplitude modulation signal.

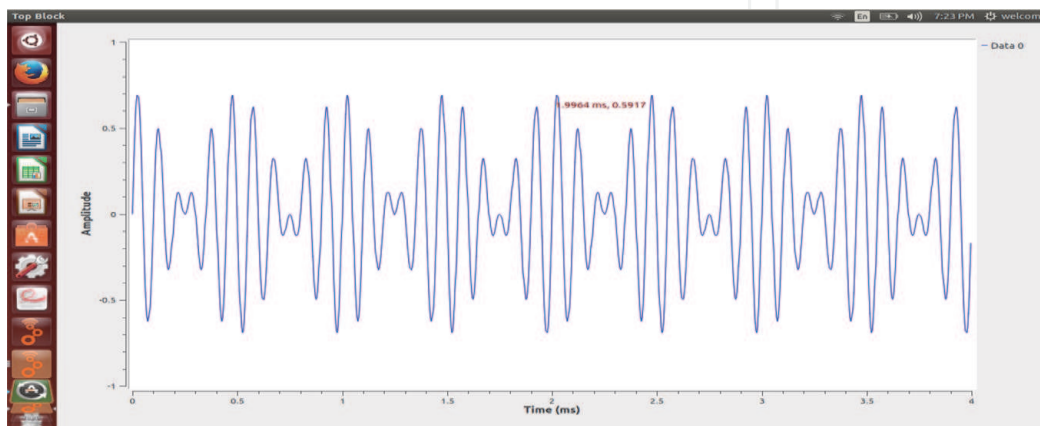

Figure 16.
 Waveform of AM modulator.

4.1.3 Functions of the blocks in flow graph

Signal Source: This block facilitates to define the sample rate, output waveform shape (pulse, square, triangle). If the frequency in the source is set higher than half of the sample rate, aliasing will occur. Offset option is also provided to add to generated waveform.

Multiply: This Block Multiplies input stream by a constant.

Output = Input * Constant Scalar/Vector (element-wise if vector).

Add Const: To obtain modulation, change the amplitude levels of modulated signal (e.g. from 0 and 1, to 1 and 2). It can be done by adding constant value to modulated signal (Component “add const”).

Throttle: Limits the data throughput to the specified sampling rate. This prevents GNU Radio from consuming all CPU resources when the flow graph is not being regulated by external hardware (i.e. audio source/sink or USRP source/sink). Specifies the data type of the input and output, the sample rate to limit the flow graph and the vector length for vector processing.

Complex Mag ^ 2: These blocks convert a complex signal to the magnitude of the complex signal and the phase angle of the complex signal. The argument v_{len} is the vector length; always use the default value 1.

Rational Re sampler: This block is Combined Interpolator and Decimator blocks. This block is used to convert from one sample rate to another as long as they can be related by a ratio: $Fs_{out} = Fs_{in} * \text{Interpolation/Decimation}$. All following block in the flow graph can able to expect the output sample rate.

Audio Sink: After completing all the processing, to play the signal through the speaker, use the audio sink. Audio sink will output the data to the sound card at the sampling rate of sampling rate.

WX Slider: Sliders are used to adjust the frequency. Sliders are used in flow-chart for adjusting carrier frequency (10–100KHz), for adjusting modulating frequency (10-1000 Hz), Volume control, Gain Control, adjusting Amplitude of signals and also used to adjust the filter cutoff frequency.

Simple AM transmitter and receiver are shown in the flow graph **Figure 17**. To transmit an audio signal of 48Khz, before the signal need to be up converted by choosing appropriate L and M values for the required sample rate conversion. However noise is predominant in this type of modulator (**Figure 18**).

SSB Modulation: Single-sideband modulation (SSB) is an improvement over amplitude modulation which uses transmitter power and bandwidth more efficiently. The data flow graph of the SSB modulator are designed using the following equations

$$s_{LSB(t)} = s(t) \times \cos(2\pi f_c t) + \hat{s}(t) \times \sin(2\pi f_c t), \text{ for lower side band} \quad (19)$$

$$s_{USB(t)} = s(t) \times \cos(2\pi f_c t) - \hat{s}(t) \times \sin(2\pi f_c t), \text{ for upper side band} \quad (20)$$

Where $s(t)$ is the information signal, $\hat{s}(t)$ is the Hilbert transform of the data signal and f_c is the carrier frequency

$$s(t) = \cos(2\pi f_c t) \quad (21)$$

For upper side band modulator the data flow graph is as shown in **Figure 19** and the output wave form in frequency domain is shown in the **Figure 20**.

4.1.4 GRC flow graph of generation of SSB modulation

Refer the following blocks such as Signal source, Throttle, Multiply and FFT Sink in the AM Modulator.

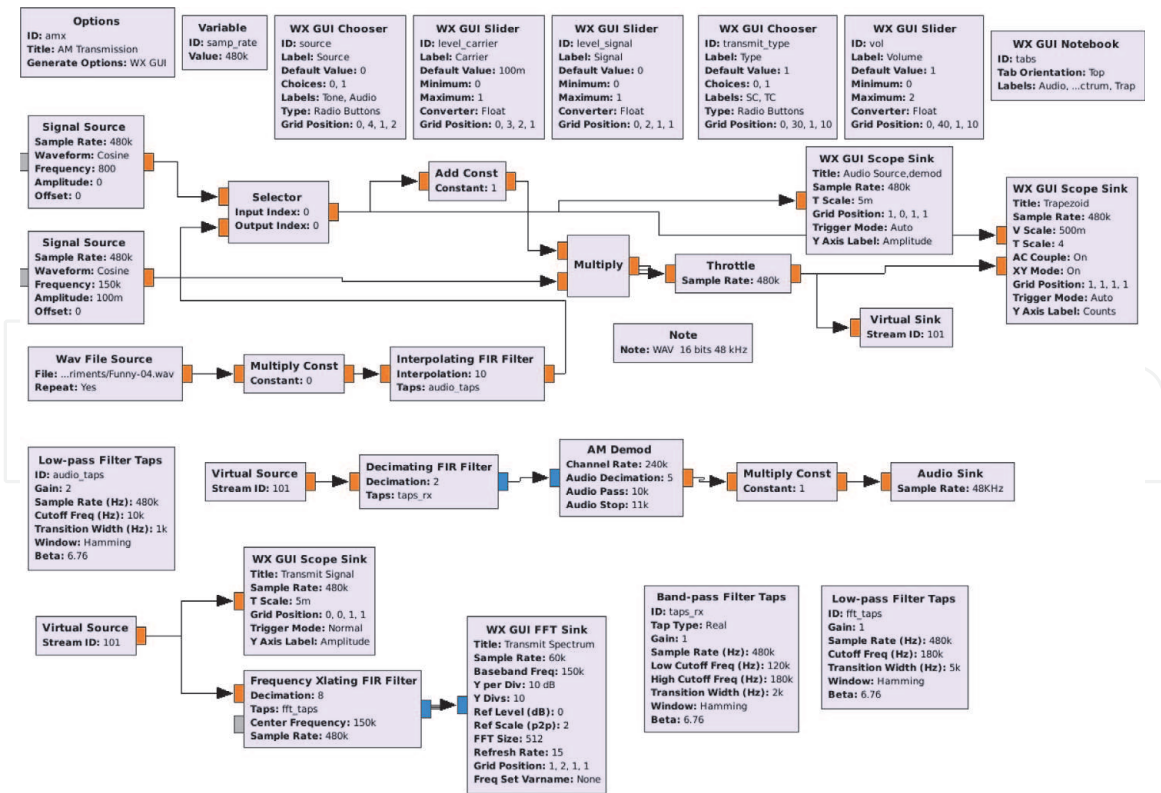

Figure 17.
 GRC flow graph for AM transmitter and receiver.

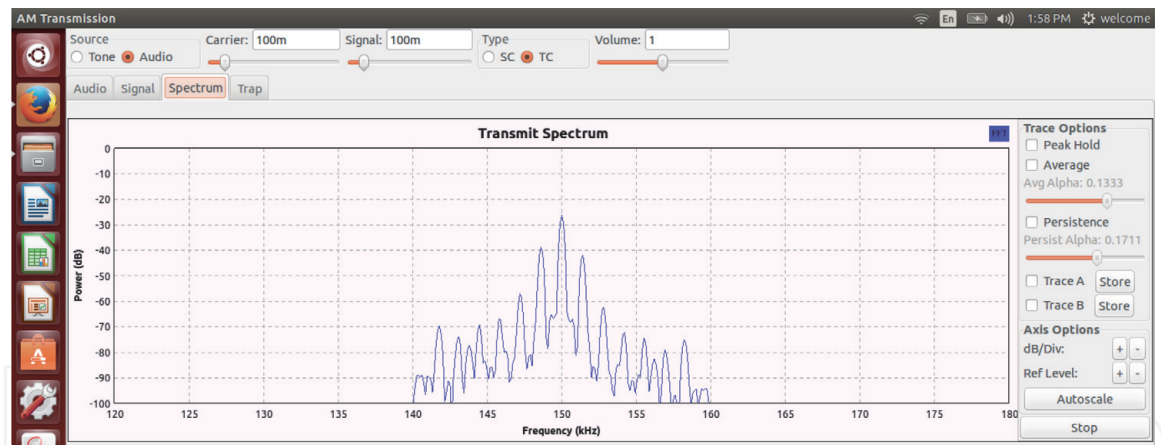

Figure 18.
 AM transmitter spectrum.

Hilbert: This block is basically a non-causal filter. For the applied real signal it performs the Hilbert transform.

Complex to Float: This block converts the complex to float, it has 2 outputs, one is real and other is imaginary output.

4.1.5 GRC flow graph for SSB transmitter and receiver

Single sideband modulation is the most suitable choice to be used for analogue voice transmission because of less power consumption and spectrum efficiency. Single sideband modulation is the most suitable choice to be used for analogue voice transmission because of less power consumption as it avoids double bandwidth and spectrum efficiency. Out of three methods to implement single-side band

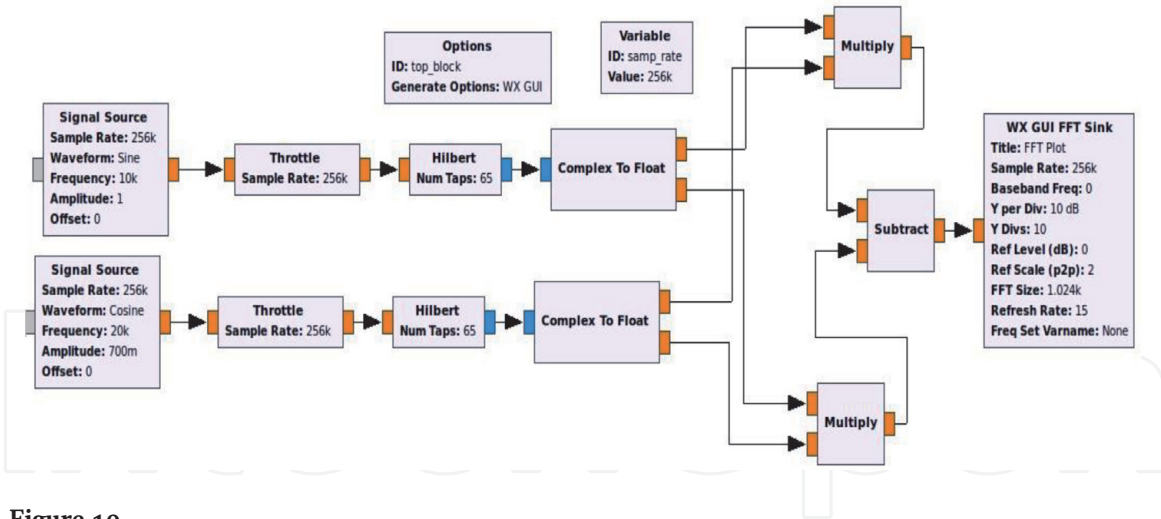

Figure 19. GRC flow graph signal generation of SSB modulator.

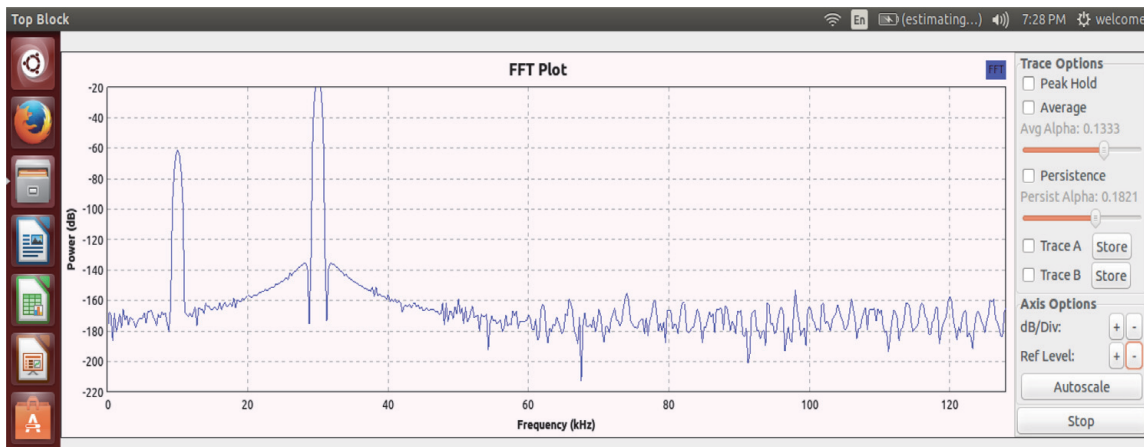

Figure 20. GRC flow graph for SSB modulation.

modulator, Band-pass filtering method has a simple structure to implement in a digital way and is shown in **Figure 21**.

Frequency Modulation: The instantaneous carrier frequency is varied according to baseband signal is called frequency modulation (**Figure 22**).

$$\text{Carrier wave } x_c(t) = A_c \cos(2\pi f_c t).$$

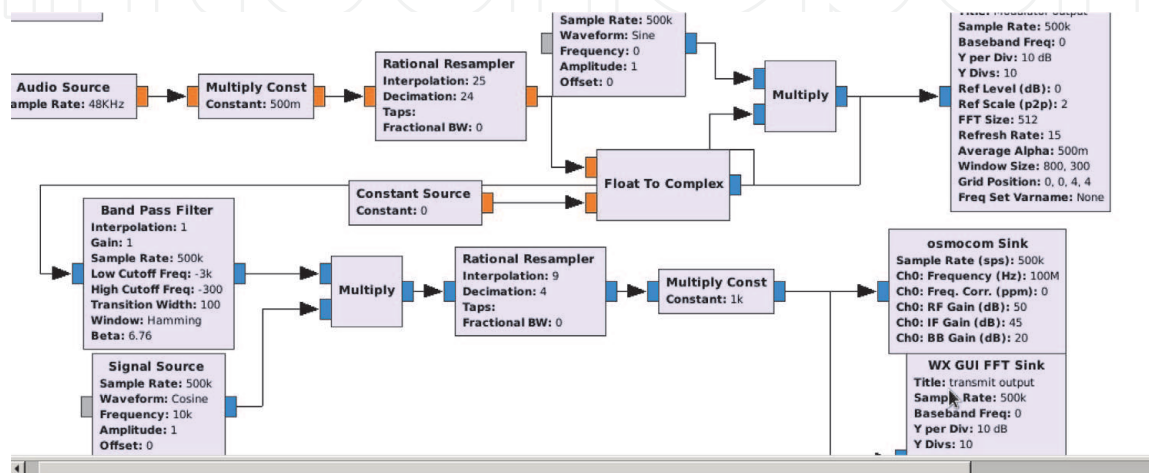

Figure 21. GRC flow graph for SSB transmitter and receiver.

The modulator output

$$Y(t) = A \cos\left(2\pi f_{\Delta} \int_0^t x_m(\tau) d\tau\right)$$

Modulation Index $f_{\Delta} = k_f A_m$.

Where k_f is the sensitivity of frequency Modulation and A_m is the amplitude of baseband signal.

4.1.6 Design of FM modulation and demodulation

VCO plays major role in FM signal generation shown in **Figure 23**. The modulation index determines the volume and sound frequency of the signal. One of the major advantage of FM is the signal can be recovered from sideband (Bessel function), FM demodulator is used to recover the baseband signal. For entertainment broadcasting applications WBFM is used, whereas NBFM is used in communication like police wireless, ambulance etc. (**Figure 24**).

4.2 Digital modulation techniques

4.2.1 ASK modulation

It is the digital to analog conversion technique. Amplitude of carrier varied according to amplitude of message signal. For binary n-1 it is called as Binary ASK (BASK) Or On off Keying Technique (OOK) [6]. Bandwidth is directly proportional to baud rate of Message signal $m(t)$.

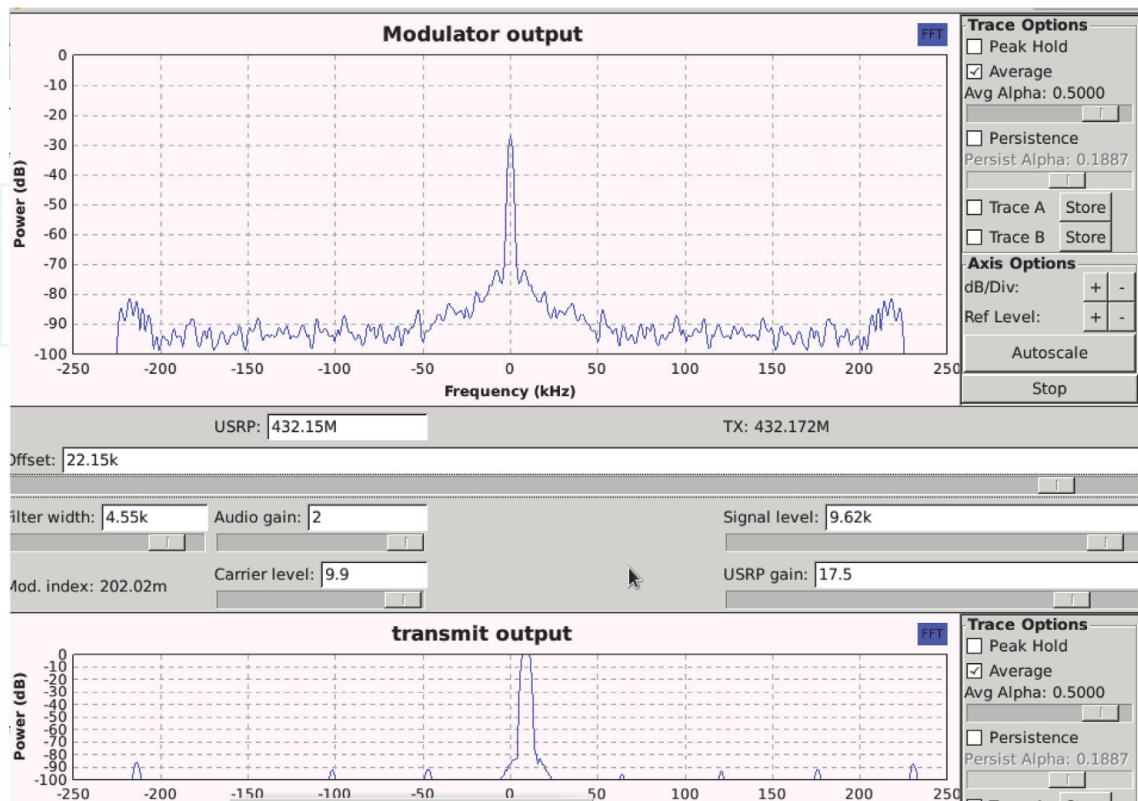

Figure 22.
 Waveform of transmission of SSB signal.

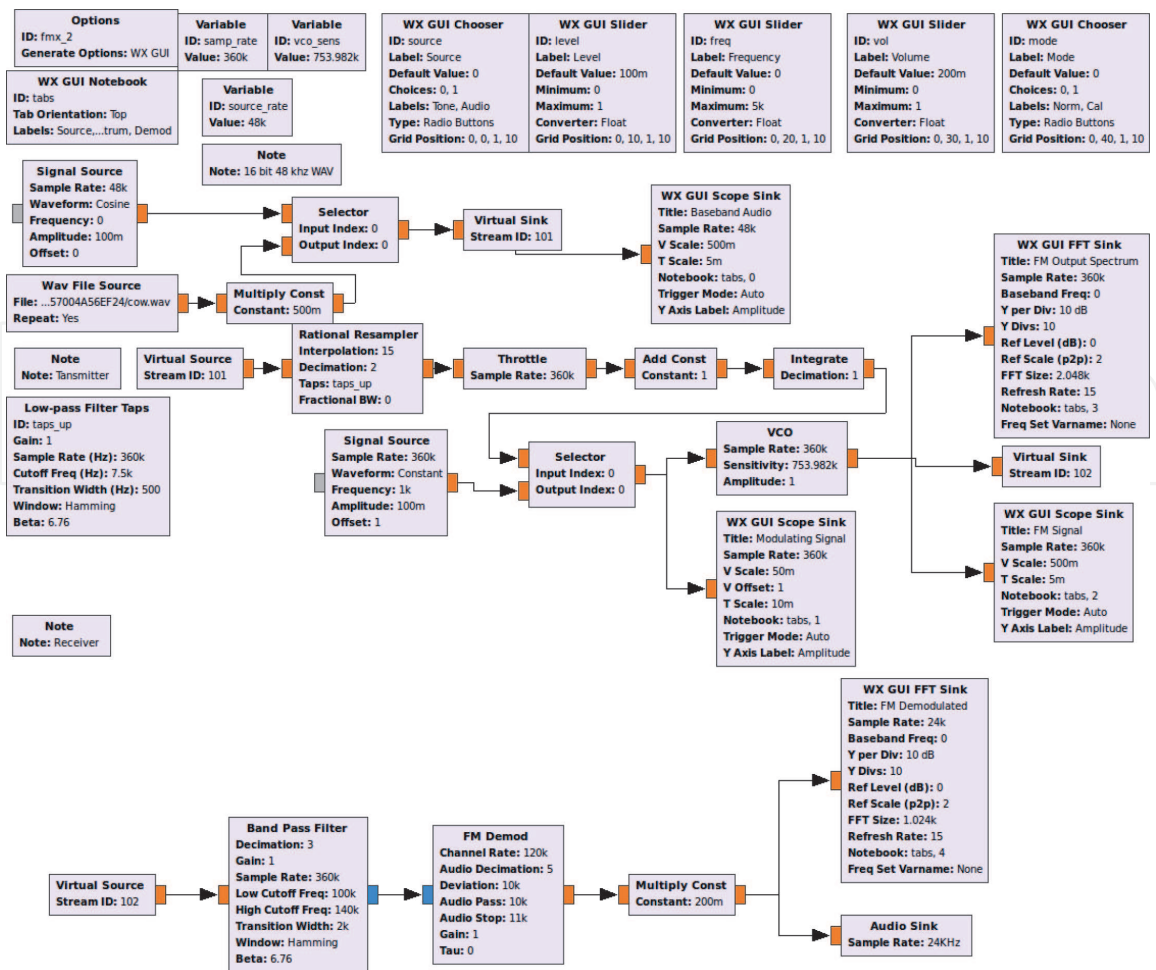

Figure 23. GRC flow graph of FM modulator and demodulator.

$$B \propto r \tag{22}$$

$$B = (1 + d)r \tag{23}$$

Where d is the factor for modulation and filtering process (Range 0 for ideal case then B = r, and 1 for worst case then B = 2r) (Figure 25).

Where baud rate = data rate /No of bits required for sample $r = R / n$

$$B = (1 + d)R/n \tag{24}$$

4.2.2 ASK demodulator

See Figure 26.

4.2.3 GRC flow graph of ASK modulation and demodulation

ASK/OOK modulation: Blocks such as Signal Source, Multiply, Throttle, Add Const blocks been discussed in AM modulation flowchart.

Float to Complex: These blocks are like ‘adapters’, used to provide the interface between two blocks with different types. If there are two inputs, they serve as the real and imaginary parts of the output signal respectively. To change the data type from floating point (real) to complex this block is deployed (Figures 27 and 28).

Channel Model: The Transmission channel model is used to best reproduce the behavior of the signal during transmission, in the form of electromagnetic wave. It is a model of the channel in which the noise is constant and spectral power density

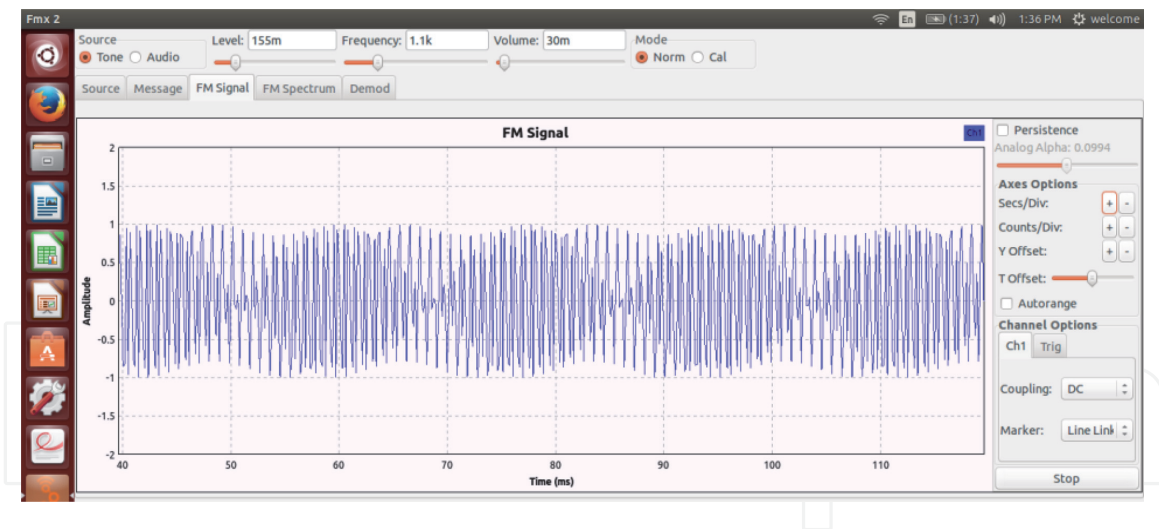

Figure 24.
 Waveform of FM modulation.

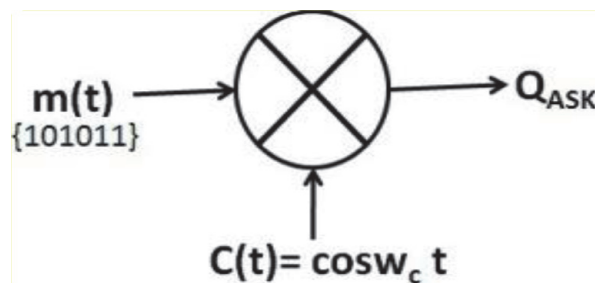

Figure 25.
 ASK modulator block diagram.

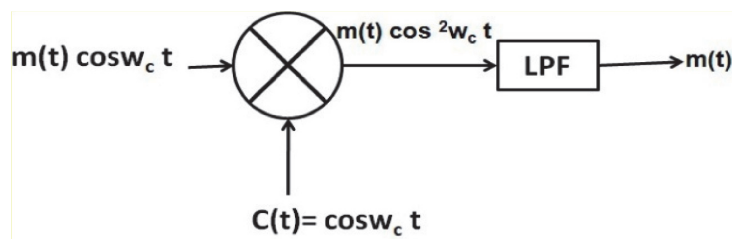

Figure 26.
 ASK demodulator block diagram.

(watts/Hz) and a Gaussian distribution of amplitude. This model is represented by the component “Channel Model”.

Frequency Xlating FIR Filter: These blocks are used as FIR Filters combined with frequency translation. Reason is that in the FPGA there are digital down converters (DDC) translating the signal from IF to baseband. To select the narrow bandwidth channel, it is necessary to perform decimating FIR Filter in order to perform frequency down sampling. From the receiver in order to performs frequency translation on the signal Frequency Xlating FIR filter is used.

Clock Recovery MM: Mueller and Müller (M&M) clock recovery is the name of one of the signal processing blocks in GNU Radio. Its task is to recover samples from a signal with the same frequency and phase as those used by the transmitter. On modern SDR systems the software layer does not have the ability to control directly the sampling rate on the ADC, usually residing in a different piece of hardware. M&M was designed in 1976 to be implemented in hardware and connected to the ADC clock reference.

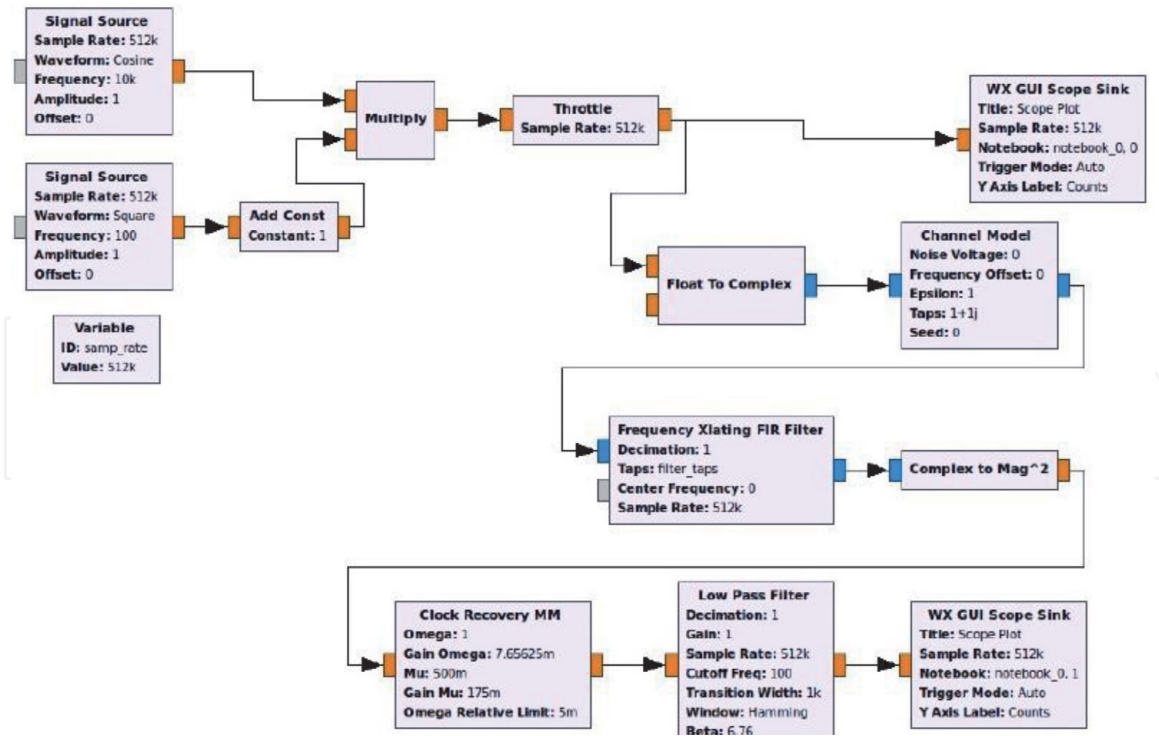

Figure 27.
GRC flow graph for ASK modulation and demodulation.

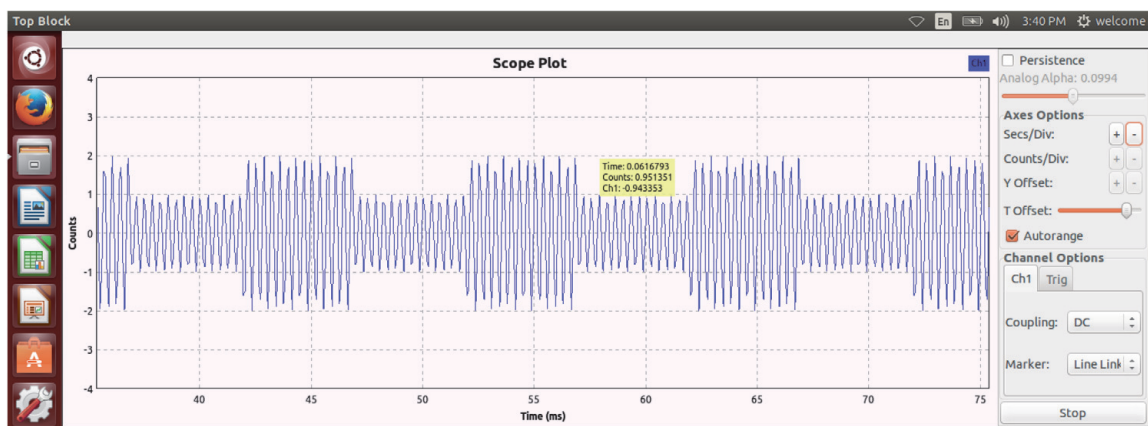

Figure 28.
Waveform of ASK modulation.

Low pass Filter: Filters are used to separate the mixed signals, extract a specific band of interest, avoid undesired effects (aliasing, imaging, etc.), and restore distorted signals. The unique features LPF block representing a digital filter in GNU Radio is that it is implemented in software, variable performances depending on the processing resources, change their properties relatively easily, can adapt to any application.

WX_Scope_Sink: This block displays the results of signal modulation on the scope.

ASK allows for two amplitude levels, two symbols 0 and 1. The transmission rate is determined by Symbol rate and Bit rate. The rate at which amplitude was changed per second is measured in Bauds. ASK is the simple modulation technique which offers high bandwidth efficiency used at radio frequencies to transmit more codes. It offers low power efficiency and very susceptible to noise interference (Figures 29–32).

4.2.4 FSK modulation

Frequency of carrier signal is varied w.r.t amplitude of message signal [8].

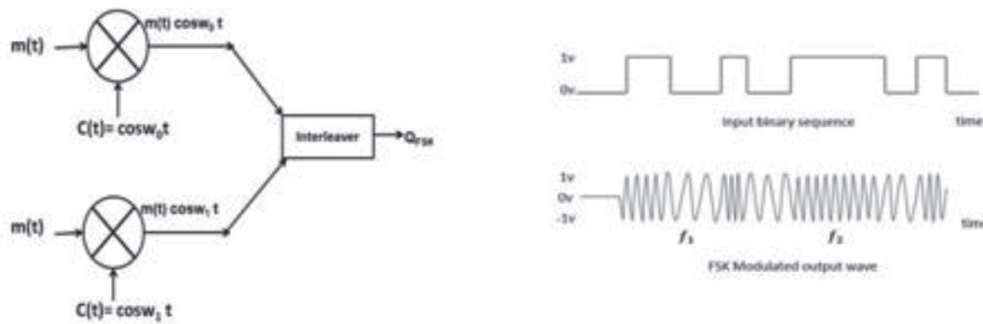

Figure 29.
 FSK generator block diagram and waveforms.

$$\varphi_{FSK} = m_0(t) \cos w_0 t \quad (25)$$

$$\varphi_{FSK1} = m_1(t) \cos w_{c1} t \quad (26)$$

$$m(t) = \begin{cases} 1 - f_{c1} \\ 0 - f_{c0} \end{cases} \quad (27)$$

$$BW_{\min} = r + r = 2r \quad (28)$$

Total Band width of FSK is $(1 + d)r = 2\Delta f$ for minimum Bandwidth = 0, substituting we get $2\Delta f = r$ (r is the baud)

4.2.5 FSK demodulator

See **Figure 30**.

4.2.6 GRC flow graph of generation of FSK modulation

See **Figures 31** and **32**.

4.2.7 FSK modulation: blocks and its functions in detail

The above flow graph shown in **Figure 20** and **Figures 27** and **28** includes the FSK transmitter and the receiver. The output frequency is 433 MHz in ISM band which is a free space to transmit. **Figures 27** and **28** shows the GRC Flow Graph of the transmitter that is described as follow.

In the above block diagram **variable Blocks** are used with sample rate 512 k Samples per second.

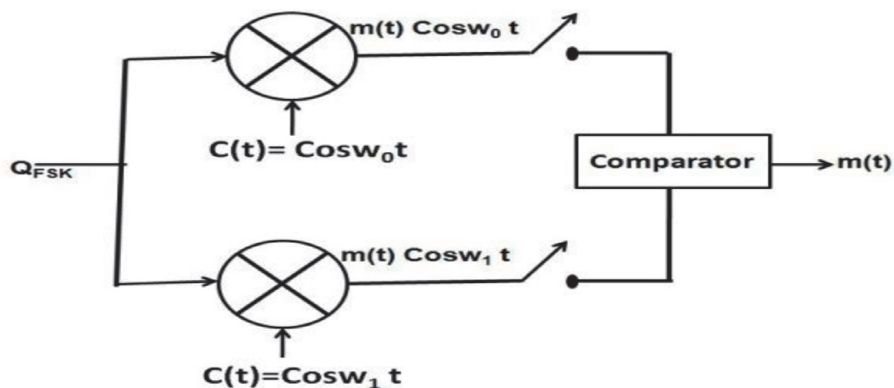

Figure 30.
 FSK demodulator block diagram.

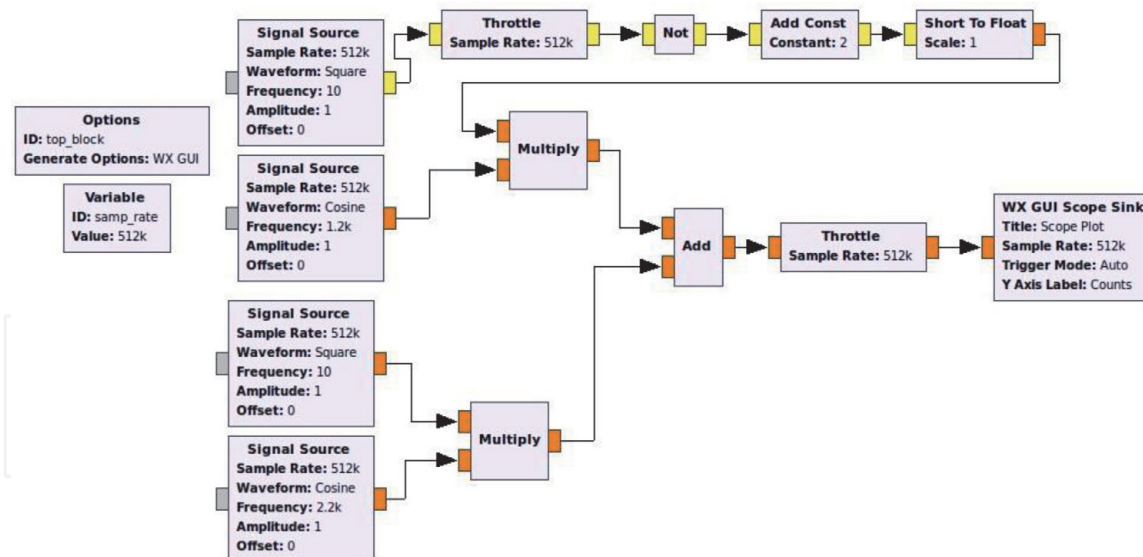

Figure 31.
GRC flow graph for FSK modulator.

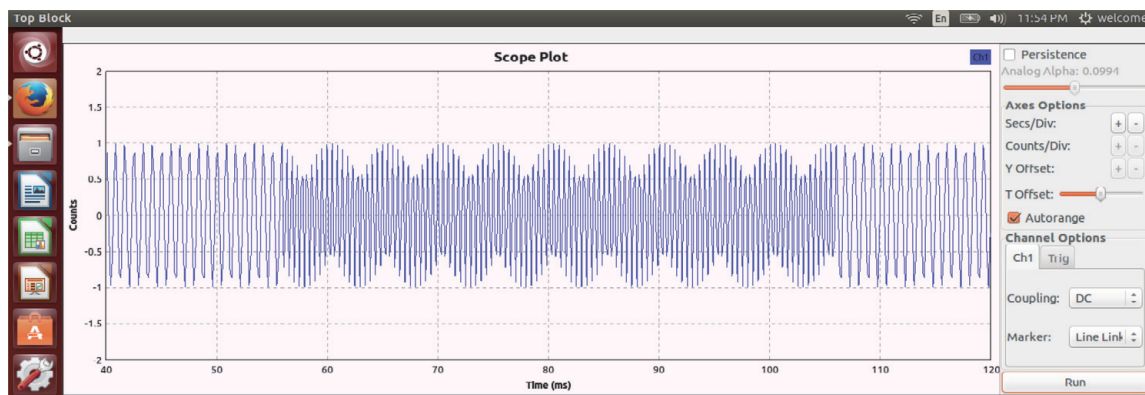

Figure 32.
Waveform of FSK modulator.

Throttle block with the sample rate proposed to keep the sample rate constant when the hardware attached to a computer.

Osmocom sink used to link the interface with HackRF one to control the output with the sample rate of 1 M, 440 M frequency, RF gain of 10 dB, IF gain of 20 dB and BB gain of 20 dB.

Add Block Implements the function $out = in + Constant$.

This block Specifies the constant to add.

4.2.8 GRC flow graph of GFSK modulation and demodulation

See **Figures 33** and **34**.

FSK Transmitter and Receiver operated in ISM band, The digital File source with the samples are first up sampled by using Sampler and to keep the sample rate constant when the hardware is not attached to a computer throttle block is used. The access code and preamble can leave blank, in Packet encoder but if new access code is created set the packet decoder codes so that match perfectly for the decoder to pass the data for synchronization. GFSKMod was for modulating. To convert complex signal Quadrature Demod Gain was set 1.

FSK has higher immunity to noise due to constant envelope, but the BER (Bit Error Rate) performance in AWGN channel is worse compare to PSK modulation.

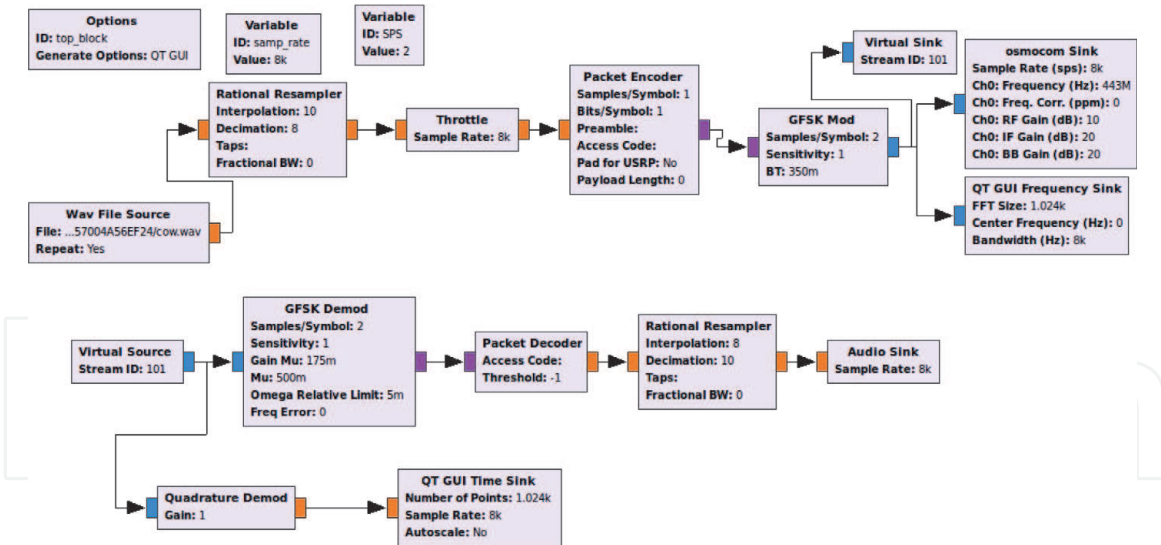

Figure 33.
 GRC flow graph of GFSK modulation and demodulation.

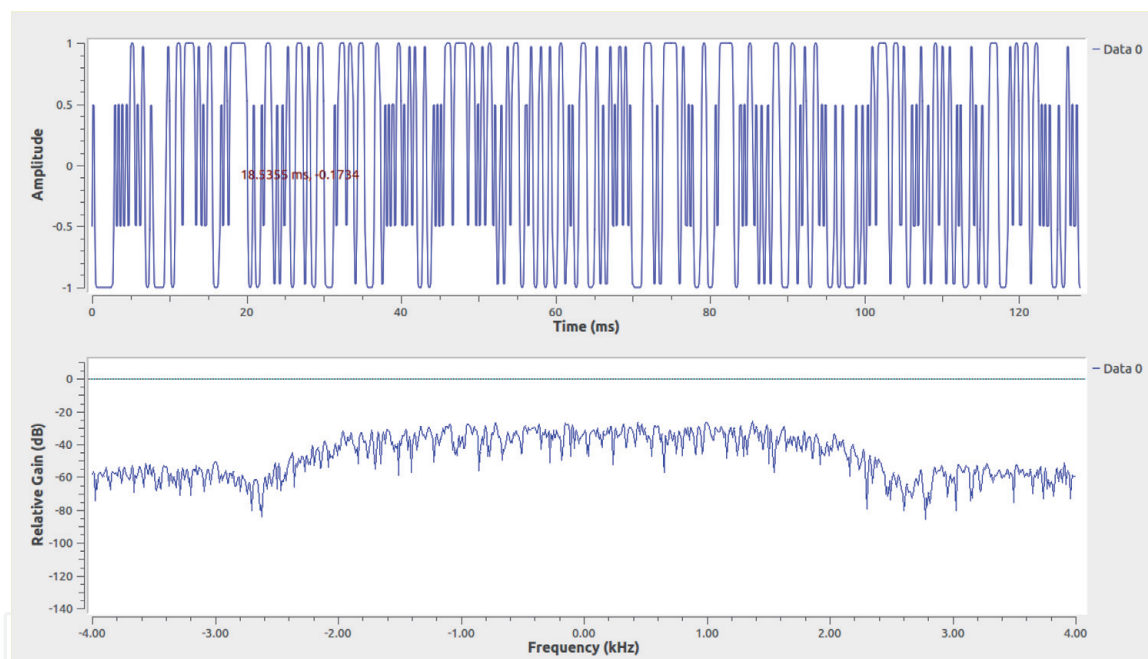

Figure 34.
 Waveform of GFSK modulation and demodulation.

4.2.9 PSK modulation

Carrier phase is varied w.r.t amplitude of message signal [2].

Binary 1 = Phase $Q = 0^\circ$

and $0^\circ =$ Phase $Q = 180^\circ$

For BPSK total levels is $L = 2$, $n = 1$ bit i.e. Phases $Q = 0^\circ$ and 180° .

For Multilevel PSK let $L = 4$, $n = 2$ bit $360/4$ i.e. Phases $Q = 0^\circ, 90^\circ, 180^\circ$, and 270° .

For Multilevel PSK let $L = 8$, $n = 3$ bit $360/8$ i.e. Phases $Q = 0^\circ, 45^\circ, 90^\circ, 135^\circ, 180^\circ, 225^\circ$, and 270° .

PSK is better than ASK and FSK Modulation. Its bandwidth is better than FSK, Less Immune to Noise, and Data rate is better than FSK Non coherent detection is not possible and costly (Figure 35).

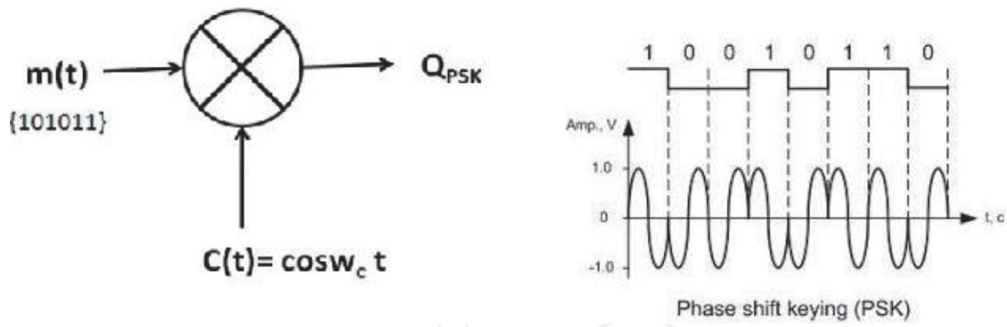

Figure 35. PSK modulator and waveforms.

$$\begin{aligned}
 Y(t) &= \varphi(t)_{PSK} \times \cos W_C t \\
 &= \pm m(t) \cos^2 W_C t \\
 &= \frac{m(t)}{2} \pm \frac{m(t)}{2 \cos^2 W_C t}
 \end{aligned}$$

4.2.10 PSK demodulator

See Figure 36.

4.2.11 GRC flow graph of generation of BPSK modulation

See Figures 37 and 38.

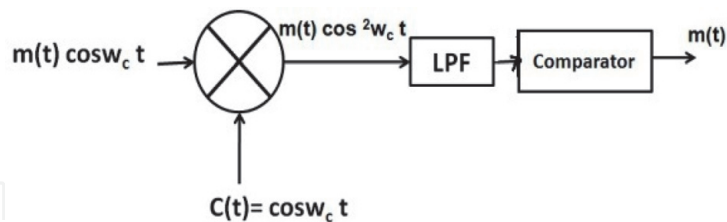

Figure 36. PSK demodulator.

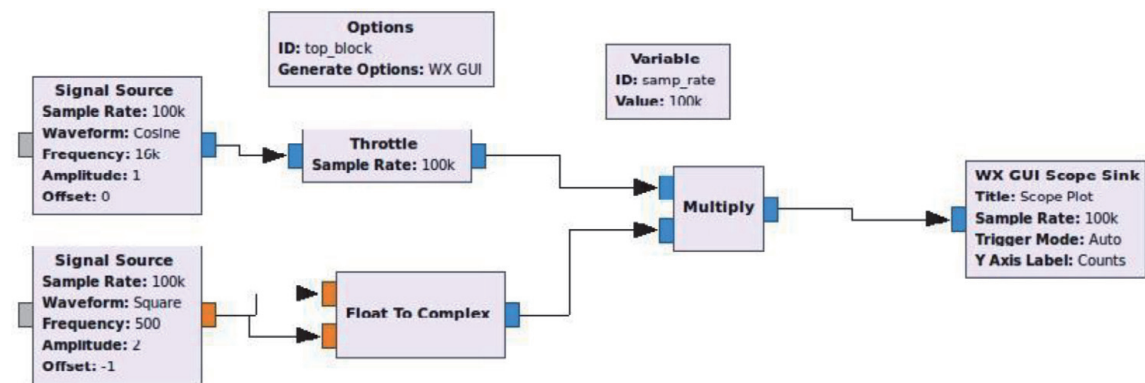

Figure 37. GRC flow graph for generation of PSK modulation.

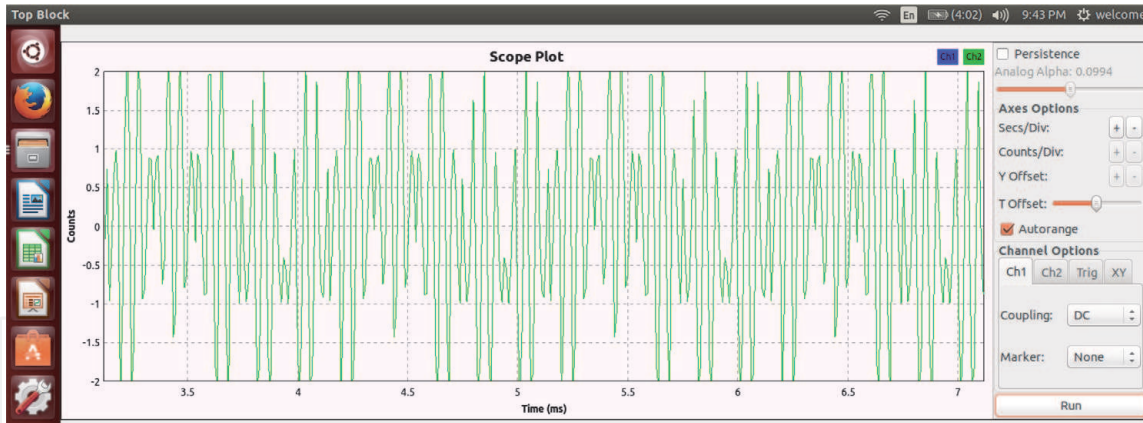

Figure 38.
 Waveform of PSK modulation.

4.2.12 PSK modulation: blocks and its function in detail

In this modulation scheme, the data bits are mapped to the phase of carrier frequency and these two are separated from each other by 180 degrees. Map 0's and 1's to φ and 0 and then add them to the phase of carrier frequency. One can view adding 0 and φ to the phase of the carrier wave, same as changing its direction without changing its magnitude.

Random source generates 0's and 1's which are converted to float. Then to map these 0's and 1's to -1 's and 1 's respectively multiply it with 2 then add -1 . ($[0\ 1] * 2 - 1$ gives us -1 or $+1$). Now feed the output in QT GUI sink block, where you'll see two dots at -1 and $+1$ on IQ-plot, same as one would expect from BPSK transmitter.

QPSK Modulation: It is an extension of the phase shift keying (PSK). As the phase of a signal is in quadrature or 90 degrees to another one it is called as quadrature. This reduces the bit rate and hence reduces the bandwidth of the channel.

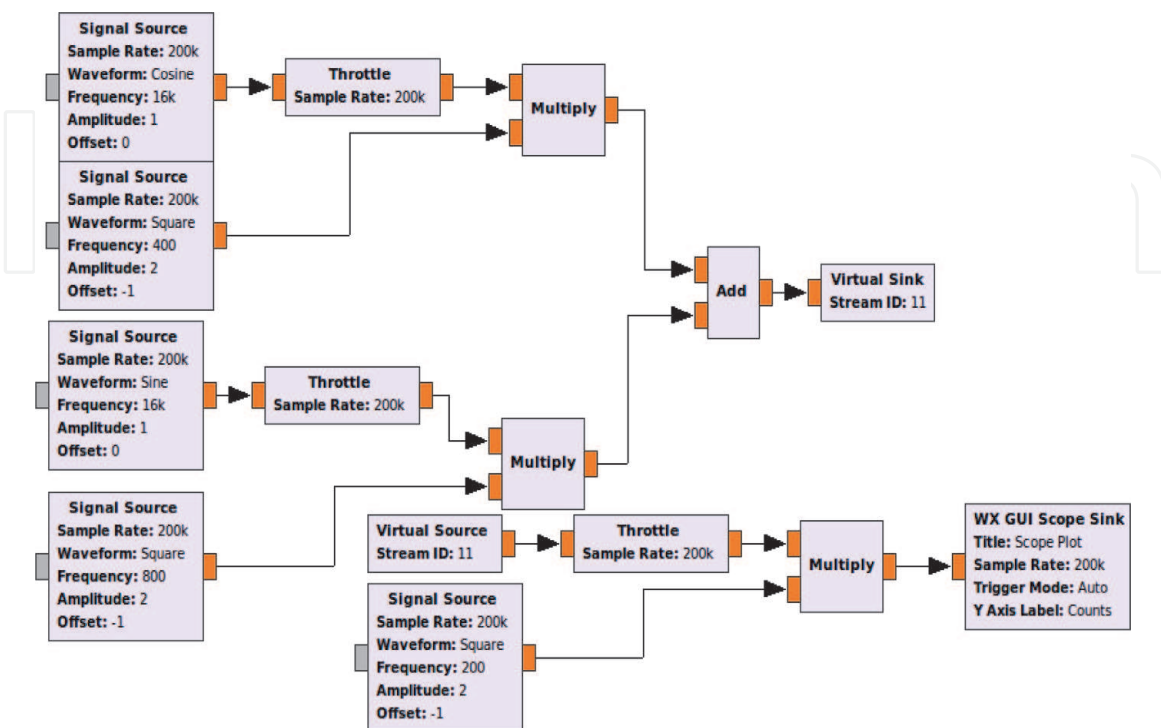

Figure 39.
 GRC flow graph of QPSK signal generation.

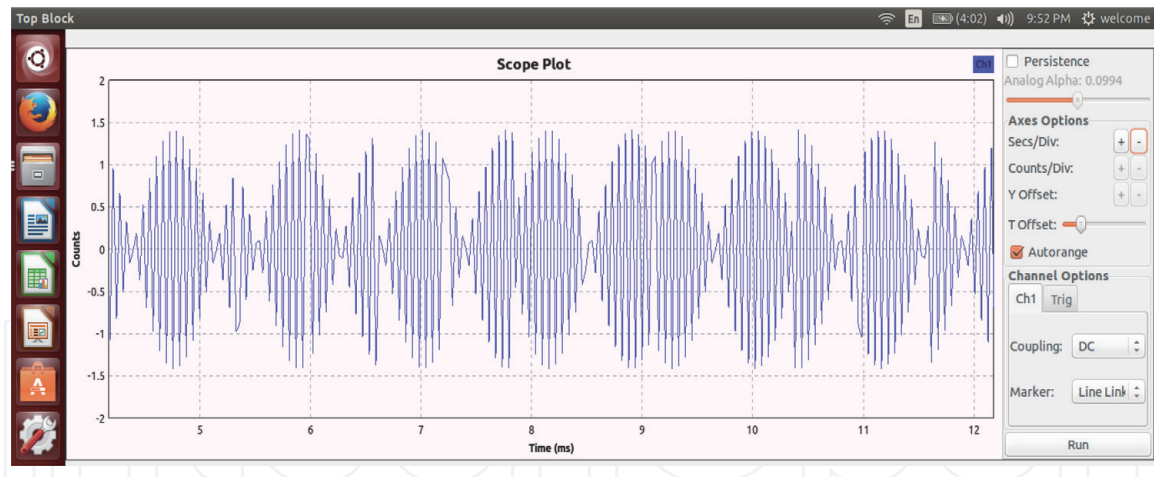

Figure 40.
Waveform of QPSK modulation.

4.2.13 GRC flowgraph of QPSK signal generation

See **Figures 39** and **40**.

4.2.14 Adaptive modulation in cognitive radio

The specialty of approaching cognitive radio is Adaptive Modulation [22], which has the ability to select the required modulation scheme necessary in the Communication system. The steps followed are. For performing this a) track the network behavior d) decision on the change of modulation techniques (ASK, BPSK, QPSK, and DPSK) during on-line transmission, while maintaining the real time objective. To scan the channel state to avail opportunistic spectrum access (OSA) and spectrum sharing.

Initial test is conducted to evaluate the performance of various modulation techniques to develop training sequence in multi-user cognitive fading environment. The performance improvement and the Spectral Efficiency both are achieved using Adaptive Modulation in cognitive radio.

5. Conclusions

In advanced communication system there is a need for smart radio which can aware of environment and select the channel with good signal strength. As a basic course this chapter covered the architecture, characteristic of SDR, and implementation of various modulation concepts using SDR. By experimenting Modulation techniques using GNU Radio, research can be extended by understanding certain real time parameters like channel characteristics and its effect, Fading caused by Multipath, Time delay Spread, Filtering and Tuning, MultiMate Signal processing blocks and its application in flow graph such as Interpolation and Decimation concepts helps to find the filter performance and tuning. It provides Visual Scope to observe Frequency/ Time domain and Constellation plots for observing real time parameters such as SNR, ISI, and BER etc. By applying concepts, with different flow graph and algorithm the SDR explore the communication system in real world scenario.

IntechOpen

IntechOpen

Author details

Madhuri Gummineni* and Trinatha Rao Polipalli
GITAM School of Technology, GITAM Deemed to be University, Hyderabad
Campus, Hyderabad, Telangana, India

*Address all correspondence to: madhuri.vijay2003@gmail.com

IntechOpen

© 2019 The Author(s). Licensee IntechOpen. This chapter is distributed under the terms of the Creative Commons Attribution License (<http://creativecommons.org/licenses/by/3.0>), which permits unrestricted use, distribution, and reproduction in any medium, provided the original work is properly cited. 

References

- [1] Farrell R, Sanchez M, Corley G. Research article software-defined radio demonstrators: An example and future trends. *International Journal of Digital Multimedia Broadcasting*. 2009:1-12. DOI: 10.1155/2009/547650. Article ID: 547650
- [2] Joshi PMP, Patil SA, Shimpi DC. Design and implementation of BPSK Audio Transmitter & Receiver Using SDR. *International Journals of Advanced Research in Computer Science and Software Engineering*. 2017; 7(6):268-271. ISSN: 2277-128X
- [3] Rebeca L, Rani S, Kakkar S. Performance analysis of various modulation techniques using GNU radio. In: *IJCA Proceedings on International Conference on Advances in Emerging Technology (ICAET 2016)*. Page no: 1–3, ICAET-Number-5 (IJCA Journal: 0975–8887); 2016
- [4] Gandhiraja R, Ramb R, Somanb KP. Analog and Digital Modulation Toolkit for Software Defined Radio. Available from: www.sciencedirect.com. www.elsevier.com/locate/procedia. doi: 10.1016/j.proeng.2012.01.9752011
- [5] Prasannan N, Jyothish Lal G, Das R, Soman KP. Software redefined communication system. *IOSR Journal of Electronics and Communication Engineering (IOSR-JECE)*. ISSN: 2278-2834, ISBN: 2278-8735. www.iosrjournals.org. 2012;4(2):16-23
- [6] Lunagariya JK, Gokhruwala K, Vachhani K. Design analysis of digital modulation schemes with GNU radio. In: *Second International Conference on Networks, Information & Communications 20 August 2015*.
- [7] Available from: http://www.sdrforum.org/pages/documentLibrary/documents/SDRF-06-R-0011-V1_0_0.pdf
- [8] Elsaghier AE, Tezel NS, Altiraiki SM. Frequency shift keying scheme to implement SDR using Hackrf one. *International Journal of Electronics Engineering Research*. 2017;9(8):1147-1157. ISSN 0975-6450, © Research India Publications. Available from: <http://www.ripublication.com>
- [9] Anjana C, Sundaresan S, Tessy Zacharia R, Gandhiraj KPS. An experimental study on channel estimation and synchronization to reduce error rate in OFDM using GNU radio. *International Conference on Information and Communication Technologies (ICICT 2014) Science Direct, Procedia computer science*. 2015;46:1056-1063. DOI: 10.1016/j.procs.2015.01.017. www.sciencedirect.com
- [10] Kavitha P, Meera Mohan K, Ra S, Gandhiraj R, Soman KP. Implementation of CDMA in GNU radio. *Procedia Computer Science*. 2015; 46:981-988. DOI: 10.1016/j.procs.2015.01.008
- [11] Khozeimeh F, Haykin S. Dynamic spectrum management for cognitive radio: An overview. *Wireless Communications and Mobile Computing*. 2009;9:1447-1459. Published online 6 January 2009 in Wiley InterScience (www.interscience.wiley.com). DOI: 10.1002/wcm.732
- [12] Liu X, Wang Y, Chen Y, Xia J, Zhang X, Lu W, et al. A multichannel cognitive radio system design and its performance optimization. *IEEE Access*. 2018;6:12327-12335. DOI: 10.1109/ACCESS.2018.2810061. Electronic ISSN: 2169-3536
- [13] Zhang X, Guo L, Song T, Xu W, Li Y, Lin J. Dynamic channel allocation supporting multi-service over cognitive radio networks. In: *16th International*

Symposium on Wireless Personal Multimedia Communications (WPMM), June 2013.

[14] Elhachmi J, Guennoun Z. Cognitive radio spectrum allocation using genetic algorithm. *EURASIP Journal on Wireless Communications and Networking*. 2016;2016:133. DOI: 10.1186/s13638-016-0620-6

[15] Hernandez C, Salgado C, López H, Rodriguez-Colina E. Multivariable algorithm for dynamic channel selection in cognitive radio networks. *EURASIP Journal on Wireless Communications and Networking*. 2015;2015:216

[16] Bharatula S. Efficient channel allocation schemes for cognitive radio networks. *International Journal of Scientific and Engineering Research*. 2014;377. ISSN 2229-5518, IJSER © 2014, <http://www.ijser.org>

[17] Kaur H, Gupta N. Localized algorithm for channel assignment in cognitive radio networks. *International Journal of Engineering Research and Applications*. 2015;5(12, (Part - 2)):171-176, www.ijera.com. ISSN: 2248-9622

[18] Thomas RR, Zayen B, Knopp R, Maharaj BT. Multiband Time-of-Arrival Positioning Technique for Cognitive Radio Systems. 2011 IEEE 22nd International Symposium on Personal, Indoor and Mobile Radio Communications ©2011 IEEE

[19] Alsharoa A, Neihart NM, Kim SW, Ahmed E. Kama Multi-band RF Energy and Spectrum Harvesting in Cognitive Radio Networks. *arXiv.org > cs > arXiv:1804.03533v1* 10 April 2018

[20] Akeela R, Dezfouli B. Software-defined radios: Architecture, state-of-the-art, and challenges. *Computer Communications*, www.elsevier.com/locate/comcom. DOI: 10.1016/j.comcom.2018.07.012

[21] Foukalas F, Khattab T, Vincent Poor H. Adaptive modulation in multi-user cognitive radio networks over fading channels. In: 2013 8th International Conference on Cognitive Radio Oriented Wireless Network. DOI: 10.4108/icst.crowncom.2013.252053

[22] Sinha D, Verma AK, Kumar S. Sample rate conversion technique for software defined radio receiver. In: 10th International Conference on Intelligent Systems and Control (ISCO); 2016. DOI: 10.1109/isco.2016.7727029

[23] Wang T, Li C. Sample rate conversion technology in software defined radio. *IEEE Xplore*. 2007: 1355-1358. DOI: 10.1109/CCECE.2006.277567. Print ISSN: 0840-7789