

We are IntechOpen, the world's leading publisher of Open Access books Built by scientists, for scientists

4,800

Open access books available

122,000

International authors and editors

135M

Downloads

Our authors are among the

154

Countries delivered to

TOP 1%

most cited scientists

12.2%

Contributors from top 500 universities



WEB OF SCIENCE™

Selection of our books indexed in the Book Citation Index
in Web of Science™ Core Collection (BKCI)

Interested in publishing with us?
Contact book.department@intechopen.com

Numbers displayed above are based on latest data collected.
For more information visit www.intechopen.com



Challenges and Applications of Impedance-Based Biosensors in Water Analysis

Kairi Kivirand, Mart Min and Toonika Rincken

Abstract

Monitoring of the environment is a global priority due to the close connection between the environmental pollution and human health. Many analytical techniques using various methods have been developed to detect and monitor the levels of pollutants (pesticides, toxins, bacteria, drug residues, etc.) in natural water bodies. The latest trend in modern analysis is to measure pollutants in real-time in the field. For this purpose, biosensors have been employed as cost-effective and fast analytical techniques. Among biosensors, impedance biosensors have significant potential for use as simple and portable devices. These sensors involve application of a small amplitude AC voltage to the sensor electrode and measurement of the in-/out-of-phase current response as a function of frequency integrated with some biorecognition element on the sensing electrodes that can bind to the target, modifying the sensor electrical parameters. However, there are some drawbacks concerning their selectivity, stability, and reproducibility. The aim of this paper is to give a critical overview of literature published during the last decade based on the development issues of impedimetric biosensors and their applicability in water analysis.

Keywords: electrochemical impedance spectroscopy, biosensor, challenges, application, water analysis

1. Introduction

Pollution of water by different chemicals disturbs ecosystems. Pollutants can also accumulate in the environment and can be found for many years after they have been banned. In addition, pollutants may accumulate into our food chain (seafood, drinking water, agricultural products, etc.) and thereby affect all living organisms including humans [1]. Some pollutants can be found years after having been banned. For example, despite being banned for agricultural use in EU in 2003 because of ubiquitous and unpreventable water contamination [2], atrazine was even after 5 years still found in spring and groundwaters at quantities between 0.9 and 2.8% of the annually applied amount before the ban [3]. Therefore, monitoring of natural water has become an essential requirement worldwide. Currently, the most common option to detect pollution is the use of fixed monitoring stations, which need trained people to analyze the collected data and are usually quite expensive. To decrease costs and make monitoring more effective, there has been an increasing interest in the development of portable and user-friendly systems, which could give us fast, precise, and reliable information.

Biosensors can be a useful tool for the detection of pollutants in the water. In comparison with traditional monitoring techniques, biosensors are portable, need minimal sample preparation, and are also rapid and reliable [4]. According to the International Union of Pure and Applied Chemistry (IUPAC) definition, a biosensor is a self-contained, integrated receptor transducer device, which is capable of providing selective quantitative or semiquantitative analytical information and which uses a biological recognition element (bio-receptor) and a transducer in direct special contact [5]. Biosensors can be used for continuous monitoring with high selectivity and sensitivity.

Biosensors are classified according to their biorecognition element or signal transducer into various categories. Electrochemical biosensors based on impedance are among the most promising ones due to their portability, rapidity, and label-free operation. Label-free sensors register changes in the electrical properties due to interactions between biological molecule attached to the sensor and an analyte present in the sample, and as these sensors generate rapid response, they can be used to track molecular events in a real-time manner [6]. The main advantage of label-free detection is that it is possible to acquire direct information of the interactions between native proteins and ligands [6, 7]. In environmental analysis most of the biosensors used are enzyme-based biosensors [8–12] or antibody-based immunosensors [13–16]. In recent years also the development of aptasensors has increased [17–19]. The present chapter gives a critical overview of the development issues and applicability of different impedimetric biosensors used for water analysis.

2. Electrochemical impedance spectroscopy

Electrochemical impedance spectroscopy (EIS) is an analytical tool, which has been used for studying electrochemical systems including corrosion [20–22], battery development [23], electrodeposition [24], fuel cells [25, 26], and charge transport through membranes [27]. For impedance measurements, the alternating current (AC) voltage applied is typically small (up to 10 mV) so that the voltage-current response is linear, allowing simple equivalent circuit analysis [28]. Different waveforms of the AC voltage $V(t)$ varying in time can be used [29]. The simplest but best-known waveform among them is a pure sine wave $V(t) = V_0 \sin(\omega t)$, which varies periodically (oscillates) with angular frequency $\omega = 2\pi f$, rad/s, where f , (1/s \equiv Hz), is the repetition frequency of oscillation periods. The current response $I(t)$ to the applied voltage $V(t)$ is also the sine wave at exactly the same frequency $\omega = 2\pi f$. In addition, the current response $I(t)$ is shifted over the time interval (Δt) against the applied voltage $V(t)$ because of containing inert energy saving components (capacitance C and/or inductance L) of impedance Z . In practice, it is reasonable to use the phase shift $\varphi = 2\pi f(\Delta t)$, rad, instead of the time interval (Δt). Predominantly, the impedance handling assumes that there are no changes in impedance value during the observation time interval. Therefore, we can exclude time dependence from the mathematical expression of impedance and use the frequency dependent impedance $Z(\omega)$ instead of $Z(t, \omega)$. Mathematical equation for the impedance $Z(\omega)$ is the ratio between the voltage-time function $V(t)$ and the resulting current-time function $I(t)$ (Eq. (1)):

$$Z(t) = \frac{V(t)}{I(t)} = \frac{V_0 \sin(2\pi ft)}{I_0 \sin(2\pi ft + \varphi)} = \frac{V_0 \sin(\omega t)}{I_0 \sin(\omega t + \varphi)} \quad (1)$$

More complicated voltage signal waveforms are required for the fast performance of EIS by generating the signal components at several frequencies simultaneously [29]. As EIS measures the response of an electrochemical cell to a voltage at

different frequencies, the data obtained allows characterizing the complex electrode systems on layers, surfaces, or membranes where electrical charge transfer and ion diffusion processes take place [7]. To evaluate and interpret the results, the EIS data are usually analyzed using Bode or Nyquist plots [30, 31].

Based on the methodologies of signal collection, impedimetric detection can be categorized in two ways: capacitive faradaic or non-faradaic. It is important to distinguish between those approaches. In electrochemical terminology, a faradaic process is the one where charge is transferred across an interface. In the case of non-faradaic, the transient currents can flow without charge transfer (e.g., charging a capacitor). In faradaic EIS, a redox probe is alternately oxidized and reduced by the transfer of an electron to and from the metal electrode. Thus, faradaic EIS requires the addition of a redox probe and direct current (DC) bias conditions such that it is not depleted. In contrast, no additional reagent is required for non-faradaic impedance spectroscopy, rendering non-faradaic schemes somewhat more amenable to point-of-care applications [32, 33].

In the case of faradaic impedimetry, the electrode surface is partially or fully covered with a non-isolating layer or with an isolating layer able to catalyze a redox probe [34]. Non-faradaic approach is also known as the direct measurement manner (without chemical reactions). In the case the redox probe is missing, the impedance depends on the conductivity of the supporting electrolyte and electrode interfacial properties. Capacitive approach means that the surface of the electrode is completely covered with a dielectric layer. In this type of sensors, no redox probe is present in the system; and the current is measured under a small amplitude sinusoidal voltage signal, at low frequencies [34]. Capacitive biosensors are mainly based on a non-faradaic approach, because the transient current flows without charge transfer and no additional reagent is required.

Briefly in faradaic approach, the charge is transferred across the electrified interface as a result of an electrochemical reaction, and in non-faradaic approach, the charge is associated with movement of electrolyte ions, reorientation of solvent dipoles, adsorption/desorption, etc. at the electrode-electrolyte interface. Detailed overviews about faradic and non-faradaic systems are given in Refs. [31, 34, 35].

In order to present information about surfaces, layers, or membranes after the immobilization of biomolecules, EIS experimental data is often analyzed using an equivalent circuit of electrochemical cell [30]. The Randle's circuit (**Figure 1**) is a frequently used equivalent for modeling the impedance [32]. The non-faradaic sensor comprises the uncompensated resistance of the electrolyte (R_s) and the constant

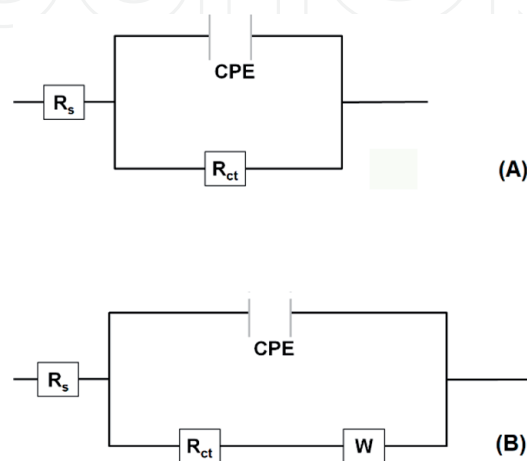

Figure 1. Simplified circuit models for (A) non-faradaic and (B) faradaic systems. Abbreviations: R_s , resistance of the electrolyte; CPE, constant phase element; R_{ct} , charge-transfer resistance; W , the Warburg impedance.

phase element (CPE) having capacitive-like properties in parallel with the charge-transfer resistance (R_{ct}).

Sometimes simplifications are introduced, and the CPE is replaced by a double-layer capacitance (C_{dl}), which introduces the constant phase shift of $-\pi/2$ rad (-90°) at all the frequencies. In reality, the CPE introduces the phase shift φ less than $\pi/2$ [29, 36].

The faradaic sensor model includes the Warburg impedance (W), which describes diffusion phenomenon taking place due to chemical redox processes. The ideal Warburg impedance introduces the phase shift of $\pi/4$. Values of the charge transfer R_{ct} and W depend on physicochemical parameters of a system. In real systems, impedance spectra are usually more complicated, and, therefore, the Randle's circuit with a corresponding plot may not give proper results [31].

3. Challenges of EIS-based biosensors

The detection of contaminants in water is very important since high pollution (heavy metals, pesticide and antibiotic residues, etc.) or the presence of pathogens (infectious microorganisms like viruses, bacteria, and fungi) can seriously endanger human health.

Several technical challenges hinder the development and construction of EIS-based biosensors: limitations to detect small molecules, reusability, and sufficient stability for repetitive measurements [37, 38]. However, the most crucial problem is whether the impedance biosensors have sufficient selectivity for their application in real samples, which typically contain an unknown amount of nontarget molecules.

There are two main types of impedimetric biosensors—with or without a specific biorecognition element [30]. The most common biorecognition elements used are specific antibodies [39, 40]. The key to the successful performance of EIS-based biosensors is how to decrease the *non-specific bindings* and increase the *selectivity*. Selectivity is particularly important in real samples where the analyte concentration can be much smaller than the concentration of nontarget molecules. Non-specific binding is typically ascribed to proteins contained in a sample matrix attaching to the sensor interface through an unwanted process not involving the bimolecular recognition [41]. One option to decrease non-specific binding is to use blocking agents like bovine serum albumin (BSA), cysteine, or ethanolamine [42–44]. The choice of a blocking agent depends on the particular system. For example, Puttharugsa and Kamolpach used BSA for prevention of non-specific binding on gold electrodes, and the selectivity of the constructed biosensors was tested toward *Escherichia coli* K12 (*E. coli* K12) as a model with EIS [45]. When BSA is adsorbed physically onto the surface, the penetration of redox probe was reduced resulting in the increase of the semicircle Nyquist curve proving that BSA prevents the adsorption of bacteria onto the blocked surface by delaying the interfacial electron-transfer kinetics and increasing the electron-transfer resistance. Riquelme et al. studied several blocking agents (mercaptoundecanol, polyethylene glycol, BSA, and chicken serum albumin) to study the effect of biomolecule size and hydrophilic properties on blocking capacity on gold electrodes [43]. Higher impedance change was observed with lower molecular weight blocking agents, due to higher molecular packing on gold electrode. In addition lower blocking agent concentrations may be required if the electrode surface has already been bio-functionalized.

In addition to blocking agents, antifouling agents can be used to prevent target depletion via non-specific bindings [46]. Blocking agent reduces the non-specific binding by blocking the active functional groups on the surface and can stabilize the biomolecule bound to the surface [47]. Antifouling (or non-fouling) agent is

a compound that has the capability to ensure the resistivity to the non-specific adsorption of proteins, cells, or other biological species [48]. Ortiz-Aguayo and Valle tried to decrease the non-specific adsorption to the graphite-epoxy composite electrode surface of an EIS-based wine aptasensor using polyethylene glycol [46]. Even though the aptasensor showed good sensitivity, the blocking did not work so efficiently; and the recovery was approximately 77%.

One of the main challenges is the *sensitivity*, which depends on the thickness of the sensing layer [49–53]. If the sensing layer is too thin, the electrode surface may be exposed, which would decrease the signal to noise ratio and decrease the sensitivity. If the sensing layer is too thick, the detected AC impedance current reduces meaning that the electron transfer between layers is hindered and the sensitivity is decreased. For example, Groß et al. studied the effect of the thickness on the base resistance in the range 30 to 150 μm and found that the sensitivity decreased along with the sensitive layer getting thicker [49]. They also found that there is a trade-off between wide linear range and high sensitivity. In addition, the sensor signal became slower as the thickness of the sensitive layer increased [49]. Functionalization of the electrodes with high-affinity biomolecules enhances besides selectivity and also the sensitivity of the system. Therefore, EIS is very often combined with different nanostructured interfaces in order to increase the amount of biorecognition material on the surface and therefore to improve the sensor sensitivity and extend its linear working [54–59]. This improvement is associated with the dimensions of nanomaterials, which endows them with a large surface/volume ratio and high specific area enabling to immobilize bigger amount of biomolecules onto biosensor surface [60].

Reusability of the antibody-based biosensors can be problematic because of the strength and irreversibility of antibody-antigen binding, and the regeneration of these surfaces without damaging the antibody layer can be complicated due to harsh conditions [61]. For impedance biosensors, extreme pH values of strong acids or bases may not be compatible with the chemistries employed for the protein immobilization, meaning that the reusability of a biosensor can be problematic. Radhakrishnan et al. studied the regeneration of antibody-based Si electrodes [62]. Even though they could regenerate the surfaces for 15 days, the impedance spectrum gradually degraded during these multiday regeneration trials.

Finally, it can be challenging to detect *small molecules* like heavy metals, pesticides, or antibiotic residues with EIS due to the exponential increase of the charge-transfer resistance through the polymer-protein layer to the underlying electrode surface [41, 63]. Small molecules (less than kDa) alone usually induce very small detectable response, which can be very difficult to measure especially in real samples where the concentration of the target molecule can be very low [41]. One possibility to improve the detection of small molecules is to conjugate these via a functional group to a larger carrier molecule (i.e., a protein) or with electrochemically bright metal and semiconductor nanomaterials, as changes due to binding of large molecules can be detected more easily. For example, Radhakrishnan et al. used impedance-based biosensor to detect two endocrine-disrupting chemicals (EDC) [41], which are small compounds found in various materials such as pesticides, additives, or contaminants in food [64]. It was found that for detecting small molecules, impedance biosensors can be operated at only one or a few frequencies that are most sensitive to analyte binding, and the sensitivity improved when attained with analyte conjugation. Gold nanoparticles (Au-NPs) have been used due to their electrochemically active surface; in particular, Au-NPs bound to the electrode digits disrupt the formation of the double layer around the electrodes, thus changing the double-layer capacitance [65–67]. For example, de Macedo et al. used Au-NPs for signal amplification, and comparing the results of free and

conjugated protein, the latter generated a measured signal 40–50 times higher and the limit of detection 64 times lower [68]. MacKay et al. also used Au-NPs to evaluate the sensing ability of biosensor chips using impedance measurements and found that the adsorption of Au-NPs to the surface binding sites increased the impedance through double-layer capacitance and higher sensitivity is gained using single frequent measurement [65].

4. Applications of EIS-based biosensors in water analysis

A range of different EIS-based biosensing technologies for the detection of pollutants like pesticides and pathogens in water samples have been developed. A condensed overview of these biosensors including a brief description of the biosensor working principles, limit of detection, working range, and reproducibility is given in **Table 1**. Although not all these devices have been commercialized, they have been successfully tested in the laboratories.

4.1 Biosensors for pesticides and toxin analysis

Jiang et al. proposed an aptamer-based biosensor for the detection of acetamiprid [59]. To increase the sensitivity of the system silver nanoparticles, decorated nitrogen-doped graphene (NG) nanocomposites were used. This aptasensor exhibited a linear response in the range of 0.1 pM–1.0 nM and a detection limit of 0.01 pM. Zehani et al. developed two impedimetric biosensors for the detection of diazinon in aqueous medium using two different types of lipase, conjugated with BSA, immobilized onto functionalized gold electrodes [69]. Diazinon is one of the most commonly used organophosphate pesticides in the world, and lipase is used to specifically catalyze the hydrolysis of diazinon into diethyl phosphorothioic acid and 2-isopropyl-4-methyl-6-hydroxypyrimidine. The developed biosensors both presented linearity up to 50 μ M with detection limit of 10 nM for *Candida rugosa*-based biosensor and 0.1 μ M for porcine pancreas-based biosensor. They also studied the reproducibility and stability. Pichetsurnthorn et al. used nanoporous impedance-based biosensor for the detection of pesticide atrazine from river water [70]. To enhance the sensitivity of the system, nanoporous alumina was overlaid on the base surface of the metal electrode. The limit of detection for the detection of atrazine in river water and in drinking water was 10 fg/ml.

Zhang et al. constructed a three-dimensional (3D) graphene-based biosensor for microcystin-LR (MC-LR) detection and quantification in drinking water [54]. Microcystin-LR is a toxin produced by cyanobacteria. EIS was used for the electrochemical characterization of the biochemical action on the electrode-specific anti-MC-LR monoclonal antibodies for the selective detection of MC-LR. A detection limit of 0.05 mg/l was achieved, which is lower than that allowed limit proposed by the World Health Organization (WHO) (1 mg/l).

4.2 Biosensors for bacterial analysis

Mutreja et al. used impedimetric immunosensor for the detection of bacteria *Salmonella typhimurium* in water with detection limit 10^1 CFU/ml [71]. Graphene-graphene oxide screen-printed electrodes were functionalized with anti-OmpD antibodies to capture *Salmonella typhimurium* through its outer membrane protein OmpD. Barreiros dos Santos et al. presented an EIS-based biosensor for the detection of pathogen *Escherichia coli* O157:H7 in water [72]. The immunosensor detection limit was 2.0 CFU/ml, and linear working range was 10 – 10^4 CFU/ml. Rengaraj

Analyte	Sample	Recognition element	Electrode	LOD	Reproducibility	Response range	References
Acetamiprid	Wastewater	Aptamer with the following sequences: 5'-(SH)-(CH ₂) ₆ -TGTAATTTGTCTGCAGCGGT TCTTGATCGCTGACACCATAT TATGAAGA-3'	Silver nanoparticles (NPs) decorated with nitrogen-doped graphene (NG) nanocomposites	33 pM	(RSD) 6.9% (n = 5)	10 pM–5 nM	[59]
Diazinon	River water	Lipase from <i>Candida rugosa</i> (CRL); lipase from porcine pancreas (PPL)	Functionalized gold electrode	10 nM (CRL); 0.1 μM (PPL)	(RSD) 2–5%	2–50 μM	[69]
Atrazine	River and bottled drinking water	Anti-atrazine antibodies	Nanoporous alumina membrane integrated with printed circuit board platform	10 fg/ml	—	10 fg/ml–1 ng/ml	[70]
Microcystin-LR (toxin produced by cyanobacteria)	Local tap water	Monoclonal microcystin antibodies (against ADDA, AD4G2, mouse IgG1)	3D-graphene-based biosensor (Ni/graphene composites coated with a PMMA solution)	0.05 μg/l	6.9% inter- and 3.6% intra-assay coefficients of variability	0.05–20 mg/l (R ₂ 0.939)	[54]
<i>Salmonella typhimurium</i> species	Water	Anti-OmpD antibodies	Graphene-graphene oxide-modified screen-printed carbon electrodes	101 CFU/ml	—	—	[71]
Pathogen <i>Escherichia coli</i> O157:H7	Water	Anti- <i>E. coli</i> antibodies	Functionalized gold electrode	2 CFU/ml	(RSD) 2% (n = 3)	10–104 CFU/ml	[72]
Bacteria	Water	Lectin <i>concanavalin A</i>	Functionalized screen-printed electrode	103 CFU/ml	—	103–107 CFU/ml	[73]

Table 1.
The application, characteristics, and construction of impedance biosensors used in water analysis.

et al. fabricated an impedimetric paper-based biosensor for the detection of bacterial contamination in water [73]. They used lectin *concanavalin A* as a bioselective element due to its stability to interact with mono- and oligosaccharides on bacterial cells. The detection limit was approximately 1000 CFU/ml.

4.3 Biosensors for drug residue detection

A good overview about aptamer-based EIS biosensors to determine different groups of antibiotics in water samples is presented in Ref. [74].

Jacobs et al. use an EIS-based microdevice, coupled with a nanoporous membrane and functionalized antibodies, to detect erythromycin in different water sources—drinking water and river water [75]. The limit of detection in drinking water was found to be around 0.1 ppt. In milk the allowed maximum residue level for erythromycin is 40 ppb. In the river water, the sensitivity is usually lower because of the organic matter in it that can interfere with binding of erythromycin. The limit of detection in the river water samples was around 1 ppt. The overall impedance change was still large enough to show if the concentrations of erythromycin are in a range of suitable or unsuitable for drinking.

5. Conclusion

In this overview main challenges and limitations of impedance biosensors, including the complexity of impedance detection, susceptibility to non-specific binding, challenges with the sensitivity, limitations to small molecule, and reusability of the electrodes are analyzed.

Abbreviations

EIS	electrochemical impedance spectroscopy
IUPAC	International Union of Pure and Applied Chemistry
$I(t)$	current response
$V(t)$	applied voltage
(Δt)	time interval
φ	phase shift
$Z(\omega)$	impedance
$V(t)$	voltage-time function
$I(t)$	current-time function
DC	direct current
R_s	resistance of the electrolyte
CPE	constant phase element
R_{ct}	charge-transfer resistance
W	the Warburg impedance
C_{dl}	double-layer capacitance
BSA	bovine serum albumin
Au-NPs	gold nanoparticles
MC-LR	microcystin-LR
WHO	World Health Organization
NG	nitrogen-doped graphene
CFU	colony-forming unit

IntechOpen

Author details

Kairi Kivirand^{1,2*}, Mart Min¹ and Toonika Rinke²

1 Thomas Johann Seebeck Department of Electronics, Tallinn Technical University, Tallinn, Estonia

2 Institute of Chemistry, University of Tartu, Tartu, Estonia

*Address all correspondence to: kairi.kivirand@ttu.ee

IntechOpen

© 2019 The Author(s). Licensee IntechOpen. This chapter is distributed under the terms of the Creative Commons Attribution License (<http://creativecommons.org/licenses/by/3.0>), which permits unrestricted use, distribution, and reproduction in any medium, provided the original work is properly cited. 

References

- [1] Goradel NH, Mirzaei H, Sahebkar A, Poursadeghiyan M, Masoudifa A, Malekshahi ZV, et al. Biosensors for the detection of environmental and urban pollutions. *Journal of Cellular Biochemistry*. 2018;**119**:207-212
- [2] Sass JB, Colangelo A. European Union bans atrazine, while the United States negotiates continued use. *International Journal of Occupational and Environmental Health*. 2006;**12**:260-267
- [3] Barth JAC, Steidle D, Kuntz D, Gocht T, Mouvet C, von Tümpling W, et al. Deposition, persistence and turnover of pollutants: First results from the EU project AquaTerra for selected river basins and aquifers. *The Science of the Total Environment*. 2007;**376**:40-50
- [4] Kivirand K, Rincken T, Kagan M. Calibrating biosensors in flow-through set-ups: Studies with glucose Optrodes. In: Rincken T, editor. *State of the Art in Biosensors*. Rijeka: IntechOpen; 2013. pp. 331-351
- [5] Nagel B, Dellweg H, Gierasch LM. Glossary for chemists of terms used in biotechnology. *Pure and Applied Chemistry*. 1992;**64**:143-168
- [6] Syahir A, Usui K, Tomizaki K, Kajikawa K, Mihara H. Label and label-free detection techniques for protein microarrays. *Microarrays*. 2015;**4**: 228-244
- [7] Brosel-Oliu S, Uria N, Abramova N, Bratov A. Impedimetric sensors for bacteria detection. In: Rincken T, editor. *Biosensors*. Rijeka: IntechOpen; 2015. pp. 257-288
- [8] Karube I, Nomura Y. Enzyme sensors for environmental analysis. *Journal of Molecular Catalysis B: Enzymatic*. 2000;**10**:177-181
- [9] Nigam VK, Shukla P. Enzyme based biosensors for detection of environmental pollutants-a review. *Journal of Microbiology and Biotechnology*. 2015;**25**:1773-1781
- [10] Tudorache M, Bala C. Biosensors based on screen-printing technology, and their applications in environmental and food analysis. *Analytical and Bioanalytical Chemistry*. 2007;**388**:565-578
- [11] Wang X, Lu X, Chen J. Development of biosensor technologies for analysis of environmental contaminants. *Trends in Environmental Analytical Chemistry*. 2014;**2**:25-32
- [12] Amine A, Mohammadi H, Bourais I, Palleschi G. Enzyme inhibition-based biosensors for food safety and environmental monitoring. *Biosensors & Bioelectronics*. 2006;**21**:1405-1423
- [13] Mallat E, Barceló D, Barzen C, Gauglitz G, Abuknesha R. Immunosensors for pesticide determination in natural waters. *TrAC, Trends in Analytical Chemistry*. 2001;**20**:124-132
- [14] Ramírez NB, Salgado AM, Valdman B. The evolution and developments of immunosensors for health and environmental monitoring: Problems and perspectives. *Brazilian Journal of Chemical Engineering*. 2009;**26**:227-249
- [15] Jiang X, Li D, Xu X, Ying Y, Li Y, Ye Z, et al. Immunosensors for detection of pesticide residues. *Biosensors & Bioelectronics*. 2008;**23**:1577-1587
- [16] Felix FS, Angnes L. Electrochemical immunosensors – A powerful tool for analytical applications. *Biosensors & Bioelectronics*. 2018;**102**:470-478
- [17] Justino CIL, Duarte AC, Rocha-Santos TAP. Recent progress in

biosensors for environmental monitoring: A review. *Sensors*. 2017;**17**:E2918

[18] Paniel N, Baudart J, Hayat A, Barthelmebs L. Aptasensor and genosensor methods for detection of microbes in real world samples. *Methods*. 2013;**64**:229-240

[19] Rapini R, Marrazza G. Electrochemical aptasensors for contaminants detection in food and environment: Recent advances. *Bioelectrochemistry*. 2017;**118**:47-61

[20] Mansfeld F. Electrochemical impedance spectroscopy (EIS) as a new tool for investigating methods of corrosion protection. *Electrochimica Acta*. 1990;**35**:1533-1544

[21] Jüttner K. Electrochemical impedance spectroscopy (EIS) of corrosion processes on inhomogeneous surfaces. *Electrochimica Acta*. 1990;**35**:1501-1508

[22] Grundmeier G, Schmidt W, Stratmann M. Corrosion protection by organic coatings: Electrochemical mechanism and novel methods of investigation. *Electrochimica Acta*. 2000;**45**:2515-2533

[23] Majchrzycki W, Jankowska E, Baraniak M, Handzlik P, Samborski R. Electrochemical impedancespectroscopy and determination of the internal resistance as a way to estimate Lead-acid batteries condition. *Batteries*. 2018;**4**:2-13

[24] Wiart R. Elementary steps of electrodeposition analysed by means of impedance spectroscopy. *Electrochimica Acta*. 1990;**35**:1587-1593

[25] Sahlin, SL, Araya SS, Andreasen SJ, Kær SK. Electrochemical impedance spectroscopy (EIS) characterization of reformate-operated high temperature PEM fuel cell stack. *International*

Journal of Power and Energy Research. 2017;**1**:20-40

[26] Yuan X, Wang H, Colin Sun J, Zhang J. AC impedance technique in PEM fuel cell diagnosis-A review. *International Journal of Hydrogen Energy*. 2007;**32**:4365-4380

[27] Park JS, Choi JH, Woo JJ, Moon SH. An electrical impedance spectroscopic (EIS) study on transport characteristics of ion-exchange membrane systems. *Journal of Colloid and Interface Science*. 2006;**300**:655-662

[28] ErtuğruL HD, Uygun ZO. Impedimetric biosensors for label-free and Enzymless detection. In: Rinken T, editor. *State of the Art in Biosensors*. Rijeka: IntechOpen; 2013. pp. 179-196

[29] Min M, Parve T, Pliquet UF. Impedance detection. In: Dongquing L, editor. *Encyclopedia of Microfluidics and Nanofluidics*. Boston: Springer; 2015. pp. 1338-1361

[30] Wang Y, Ye Z, Ying Y. New trends in impedimetric biosensors for the detection of foodborne pathogenic bacteria. *Sensors*. 2012;**12**:3449-3471

[31] Uygun ZO, Ertuğrul Uygun HD. A short footnote: Circuit design for faradaic impedimetric sensors and biosensors. *Sensors and Actuators B: Chemical*. 2014;**31**:448-453

[32] Daniels JS, Pourmand N. Label-free impedance biosensors: Opportunities and challenges. *Electroanalysis*. 2007;**19**:1239-1257

[33] Reddy B, Salm E, Bashir R. Electrical chips for biological point-of-care detection. *Annual Review of Biomedical Engineering*. 2016;**18**:329-355

[34] Prodromidis MI. Impedimetric immunosensors-a review. *Electrochimica Acta*. 2010;**55**:4227-4233

- [35] Santos A, Davis JJ, Bueno PR. Fundamentals and applications of impedimetric and redox capacitive biosensors. *Journal of Analytical and Bioanalytical Techniques*. 2014;**S7**:016
- [36] David N-H, Javier R-T, Min M. Fundamentals, recent advances and future challenges in bioimpedance devices for healthcare applications. *Journal of Sensors*. 2019;**5**:1-42
- [37] Heo J, Hua SZ. An overview of recent strategies in pathogen sensing. *Sensors*. 2009;**9**:4483-4502
- [38] Bogomolova A, Komarova E, Reber K, Gerasimov T, Yavuz O, Bhatt S, et al. Challenges of electrochemical impedance spectroscopy in protein biosensing. *Analytical Chemistry*. 2009;**81**:3944-3949
- [39] Baryeh K, Takalkar S, Lund M, Liu G. Introduction to medical biosensors for point of care applications. In: Narayan RJ. Editor. *Medical Biosensors for Point of Care (POC) Applications* Woodhead Publishing. 2017. p. 3-25
- [40] Morales MA, Halpern JM. Guide to selecting a biorecognition element for biosensors. *Bioconjugate Chemistry*. 2018;**29**:3231-3239
- [41] Radhakrishnan R, Suni II, Bever CS, Hammock BD. Impedance biosensors: Applications to sustainability and remaining technical challenges. *ACS Sustainable Chemistry & Engineering*. 2014;**2**:1649-1655
- [42] Frederix F, Bonroy K, Reekmans G, Laureyn W, Campitelli A, Abramov MA, et al. Reduced nonspecific adsorption on covalently immobilized protein surfaces using poly(ethylene oxide) containing blocking agents. *Journal of Biochemical and Biophysical Methods*. 2004;**58**:67-74
- [43] Riquelme MV, Zhao H, Srinivasaraghavan V, Pruden A, Vikesland P, Agah M. Optimizing blocking of nonspecific bacterial attachment to impedimetric biosensors. *Sensing and Bio-Sensing Research*. 2016;**8**:47-54
- [44] Contreras-Naranjo JE, Aguilar O. Suppressing non-specific binding of proteins onto electrode surfaces in the development of electrochemical immunosensors. *Biosensors*. 2019;**9**:15
- [45] Chokchai P, Kamolpach R. Investigation of bovine serum albumin and casein adsorption on gold surface by using electrochemical impedance spectroscopy. *Srinakharinwirot Science Journal*. 2015;**31**:18-31
- [46] Ortiz-Aguayo D, del Valle M. Label-free aptasensor for lysozyme detection using electrochemical impedance spectroscopy. *Sensors*. 2018;**18**:E354
- [47] Xiao Y, Isaacs SN. Enzyme-linked immunosorbent assay (ELISA) and blocking with bovine serum albumin (BSA)-not all BSAs are alike. *Journal of Immunological Methods*. 2012;**384**:148-151
- [48] Utrata-Wesoek A. Antifouling surfaces in medical application. *Polimery*. 2013;**58**:685-695
- [49] Groß A, Richter M, Kubinski DJ, Visser JH, Moos R. The effect of the thickness of the sensitive layer on the performance of the accumulating NO_x sensor. *Sensors*. 2012;**12**:12329-12346
- [50] Comeau KD, Meli MV. Effect of alkanethiol chain length on gold nanoparticle monolayers at the air-water interface. *Langmuir*. 2012;**28**:377-381
- [51] Campuzano S, Pedrero MM, Montemayor CC, Fatás E, Pingarrón JM, Fatas E, et al. Characterization of alkanethiol-self-assembled monolayers-modified gold electrodes by electrochemical impedance spectroscopy. *Journal*

of Electroanalytical Chemistry.
2006;**586**:112-121

[52] Bhadra P, Shajahan MS, Bhattacharya E, Chadha A. Studies on varying n-alkanethiol chain lengths on a gold coated surface and their effect on antibody-antigen binding efficiency. *RSC Advances*. 2015;**5**:80480-80487

[53] Braiek M, Rokbani KB, Chrouda A, Mrabet B, Bakhrouf A, Maaref A, et al. An electrochemical immunosensor for detection of *Staphylococcus aureus* bacteria based on immobilization of antibodies on self-assembled monolayers-functionalized gold electrode. *Biosensors*. 2012;**2**:417-426

[54] Zhang W, Han C, Jia B, Saint C, Nadagouda M, Falaras P, et al. A 3D graphene-based biosensor as an early microcystin-LR screening tool in sources of drinking water supply. *Electrochimica Acta*. 2017;**236**:319-327

[55] Mehta J, Bhardwaj N, Bhardwaj SK, Tuteja SK, Vinayak P, Paul AK, et al. Graphene quantum dot modified screen printed immunosensor for the determination of parathion. *Analytical Biochemistry*. 2017;**523**:1-9

[56] Bonanni A, Loo AH, Pumera M. Graphene for impedimetric biosensing. *TrAC, Trends in Analytical Chemistry*. 2012;**37**:12-21

[57] Aceta Y, del Valle M. Graphene electrode platform for impedimetric aptasensing. *Electrochimica Acta*. 2017;**229**:458-466

[58] Shao Y, Wang J, Wu H, Liu J, Aksay IA, Lin Y. Graphene based electrochemical sensors and biosensors: A review. *Electroanalysis*. 2010;**22**:1027-1036

[59] Jiang D, Du X, Liu Q, Zhou L, Dai L, Qian J, et al. Silver nanoparticles anchored on nitrogen-doped graphene as a novel electrochemical biosensing

platform with enhanced sensitivity for aptamer-based pesticide assay. *The Analyst*. 2015;**140**:6404-6411

[60] Tîlmaciu C-M, Morris MC. Carbon nanotube biosensors. *Frontiers in Chemistry*. 2015;**27**:1-21

[61] Goode JA, Rushworth JVH, Millner PA. Biosensor regeneration: A review of common techniques and outcomes. *Langmuir*. 2015;**31**:6267-6276

[62] Radhakrishnan R, Suni II. Antibody regeneration on degenerate Si electrodes for calibration and reuse of impedance biosensors. *Sensing and Bio-Sensing Research*. 2016;**7**:20-24

[63] Bradbury CR, Zhao J, Fermín DJ. Distance-independent charge-transfer resistance at gold electrodes modified by thiol monolayers and metal nanoparticles. *Journal of Physical Chemistry C*. 2008;**112**:10153-10160

[64] Bergman Å, Heindel J, Jobling S, Kidd K, Zoeller RT. State-of-the-science of endocrine disrupting chemicals, 2012. *Toxicology Letters*. 2012;**S17**:53

[65] MacKay S, Abdelrasoul G, Tamura M, Lin D, Yan Z, Chen J. Using impedance measurements to characterize surface modified with gold nanoparticles. *Sensors*. 2017;**17**:2141

[66] Wang J, Profitt JA, Puglia MJ, Suni II. Au nanoparticle conjugation for impedance and capacitance signal amplification in biosensors. *Analytical Chemistry*. 2006;**78**:1768-1773

[67] Li Y, Schluesener HJ, Xu S. Gold nanoparticle-based biosensors. *Gold Bulletin*. 2010;**43**:29-41

[68] de Macedo EF, Formaggio DMD, Santos NS, Tada DB. Gold nanoparticles used as protein scavengers enhance surface plasmon resonance signal. *Sensors*. 2017;**17**:2765

[69] Zehani N, Dzyadevych SV, Kherrat R, Jaffrezic-Renault NJ. Sensitive impedimetric biosensor for direct detection of diazinon based on lipases. *Frontiers in Chemistry*. 2014;**2**:44

[70] Pichetsurnthorn P, Vattipalli K, Prasad S. Nanoporous impedimetric biosensor for detection of trace atrazine from water samples. *Biosensors & Bioelectronics*. 2012;**32**:155-162

[71] Mutreja R, Jariyal M, Pathania P, Sharma A, Sahoo DK, Suri CR. Novel surface antigen based impedimetric immunosensor for detection of salmonella typhimurium in water and juice samples. *Biosensors & Bioelectronics*. 2016;**85**:707-713

[72] Barreiros dos Santos M, Aguil JP, Prieto-Simón B, Sporer C, Teixeira V, Samitier J. Highly sensitive detection of pathogen *Escherichia coli* O157:H7 by electrochemical impedance spectroscopy. *Biosensors & Bioelectronics*. 2013;**45**:174-180

[73] Rengaraj S, Cruz-Izquierdo A, Scott JL, Di Lorenzo M. Impedimetric paper-based biosensor for the detection of bacterial contamination in water. *Sensors and Actuators B: Chemical*. 2018;**265**:50-58

[74] Mehlhorn A, Rahimi P, Joseph Y. Aptamer-based biosensors for antibiotic detection: A review. *Biosensors*. 2018;**8**:54

[75] Jacobs M, Nagaraj VJ, Mertz T, Selvam AP, Ngo T, Prasad S. An electrochemical sensor for the detection of antibiotic contaminants in water. *Analytical Methods*. 2013;**5**(17):4325-4329