

# We are IntechOpen, the world's leading publisher of Open Access books Built by scientists, for scientists

**4,800**

Open access books available

**122,000**

International authors and editors

**135M**

Downloads

Our authors are among the

**154**

Countries delivered to

**TOP 1%**

most cited scientists

**12.2%**

Contributors from top 500 universities



**WEB OF SCIENCE™**

Selection of our books indexed in the Book Citation Index  
in Web of Science™ Core Collection (BKCI)

Interested in publishing with us?  
Contact [book.department@intechopen.com](mailto:book.department@intechopen.com)

Numbers displayed above are based on latest data collected.  
For more information visit [www.intechopen.com](http://www.intechopen.com)



---

# An Economic Growth Model Using Hierarchical Bayesian Method

---

Nur Iriawan and Septia Devi Prihastuti Yasmirullah

Additional information is available at the end of the chapter

<http://dx.doi.org/10.5772/intechopen.88650>

---

## Abstract

Economic growth can be used as an assessment for the success of the regional economic establishment. Since the Regulation of the Republic Indonesia Number 32 of 2004 has been implemented, the imbalance economic growth among the regencies in Indonesia is rising. The imbalance in the conditions of economic growth differs between regions with the aim of the government to improve social welfare by expanding economic activities in each region. The purpose of this chapter is to elaborate whether there is a difference in economic growth based on the distribution of bank credit for each regency in Indonesia. This research analyzes the economic growth data using hierarchical structure model that follows the normality-based modeling in the first level. The two modeling approaches will be applied, i.e., a general one-level Bayesian approach and a two-level structure hierarchical Bayesian approach. The success of these approaches has demonstrated that the two-level hierarchical structure Bayesian has a better estimation than a general one-level Bayesian. It demonstrates that all of the macro-level characteristics of provinces are significantly influencing the different economic growth in every related province. These variations are also significantly influenced by their cross-level interaction regency and provincial characteristics.

**Keywords:** Bayesian, estimation, economic growth, normal distribution, hierarchical

---

## 1. Introduction

The rising economic development in a country or in such region can be shown by its economic growth. It could be affected by three main factors, i.e., advances in technology, the capital accumulation of investment, and the local workforce participation [1]. The indicator to measure the economic growth rate and to determine the shifts and economic structural changes are

the gross domestic product (GDP). There were two kinds of GDP, i.e., GDP at constant prices and GDP at current prices. GDP at constant prices was used to explain the economic growth from year to year, while GDP at current prices was used to see the economic structural changes [2].

The law of the Republic Indonesia Number 32 of 2004 states about the delegation of partial of the central government authority to the local government for conducting and organizing its own internal affairs. The increase of the economic activity in each regency and province in order to improve the national economy is the main goal of the delegation. Local autonomy welfare of society expected quickly can be realized through applied decentralization regulation. Decentralization, on the other hand, can drive the imbalances in economic growth among the regencies.

The Indonesian government issued the nine packages policy called Nawacita in 2014, a proposed solution to overcome the imbalance of economic growth. The nine packages policy in Nawacita consists of returning the state to have the main task of protecting all citizens and providing a safe living environment; emerging clean, effective, trusted, and good democratic governance; development of marginal areas; reforming law enforcement bureaus; improving life quality; increasing productivity and competitiveness; promoting economic independence by developing domestic strategic sectors; overhauling the nation character; and strengthening the spirit of unity in diversity and social reform [3].

The seventh of the nine points in Nawacita states that the government would accomplish economic independence by developing domestic strategic sectors. The economy sectors were stressed as a priority sector for accompanying Nawacita, which fitted the classification Indonesia Banking Statistics (named as Statistik Perbankan Indonesia or SPI). Economic growth is significantly affected by these sectors. A significant example is that the distribution of financial credit to economic priority sectors has been proven to have a significant contribution as a positive impact on regional economic growth [4].

As a developing country, the banking sector in Indonesia is still dominating the financial system. The development of the banking sector has a strong relationship with economic growth. Some previous studies have shown that there is a positive relationship between the number of bank credit with income per capita growth in both developed and developing countries [5, 6]. The banking industry characteristic in Indonesia, however, is believed relatively brittle [7], inefficient in financing intermediation in ASEAN [4].

This chapter discusses the bank credit influence on economic growth through an assessment of the distribution of financial credit in Indonesia using two-level Bayesian hierarchical structure modeling, each regency on the first level as a sample unit and provinces as the second level. There are 284 regencies as the selected sample unit from the first level, which spread unbalanced in the 11 selected provinces. Demonstration of the ability to resolve the challenges of modeling on this unbalance of a number of sample units, therefore, was a significant contribution of Bayesian hierarchical modeling. Different from the frequentist approaches, Bayesian analysis treats all unknown parameters as random variables which have distribution [8]. The results of this study are expected to provide guidance about financial credit distribution to

priority sector and recommendation to policy-making in Bank Indonesia, the local government, Statistics Indonesia (BPS), and other related institutions.

## 2. Background and methodology

Economic growth has always been a benchmark for the success of the economic development of a country or a region. In a region, it can be conventionally measured by the increasing rate of the gross regional domestic product (GRDP) value represented in percent. The important indicators that represent the economic condition in a region for a certain reporting period were GRDP. There were two types of GRDP, i.e., reported as current prices and reported as constant prices. The performance of the economy over time in real terms could be seen through the GRDP at constant prices, while GRDP at current prices was used to see the shifts and the economic structures [2]. The economic growth rate in Indonesia during 2015 is lower than in 2014, i.e., 4.79% of 5.02%. Some provinces, however, have economic growth above national economic growth, which are West Sumatra, North Sumatra, East Java, Central Java, West Java, East Nusa Tenggara, Southeast Sulawesi, South Sulawesi, and Papua, while the economic growth rate of South Sumatra (4.5%) is lower than the national economic growth. In 2015, Papua Province was an exceptional province having the most fantastic rapid economic growth rate, amounting to 7.97%. The second most rapid economic growth rate after Papua Province belongs to South Sulawesi Province, achieving 7%. Five provinces were only able to reach the economic growth rate of around 5–6%, and one province exactly had a growth of 6%. The others grow below 5%. Almost all provinces that have GRDP at constant prices tend to increase from 2014 to the year 2015, except Aceh Province. The deficit balance of trade, foreign export oil, and imports are the main cause of decreasing its GRDP. They have reduced the level of Aceh's domestic economy (inter-regional) and sharpened differences in economic growth.

The secondary data recorded officially from the Economic Assessment and Surveillance Division of Economic and Financial Advisory, Bank Indonesia Representative Office of East Java Province, coupled with the data from Statistics Indonesia (BPS) are used in this study. There are 17 micro predictor variables ( $x$ ), four macro predictor variables ( $w$ ), and a response variable ( $y$ ), i.e., economic growth rate. **Figure 1** shows the design of the hierarchical data structure. Due to the demand for the number of sample units as many as 17 variables in the modeling, only 11 provinces were used from as many as 34 provinces in Indonesia which had at least 16 regencies. This considers the guarantee in approaching the fulfillment of the requirements of the micro model that uses 17 predictor variables.

The procedures of analysis in this research follow the steps below:

1. Describing and exploring economic growth data each regency
2. Parameter estimation of a global one-level Bayesian model of all regencies
  - a. Write an algorithm to estimate parameters of the general one-level Bayesian model.

The parameters used for modeling in this study are  $\tau$  and  $\beta$ . These are the parameters of the normal distribution. The preliminary procedure that needs to be done in

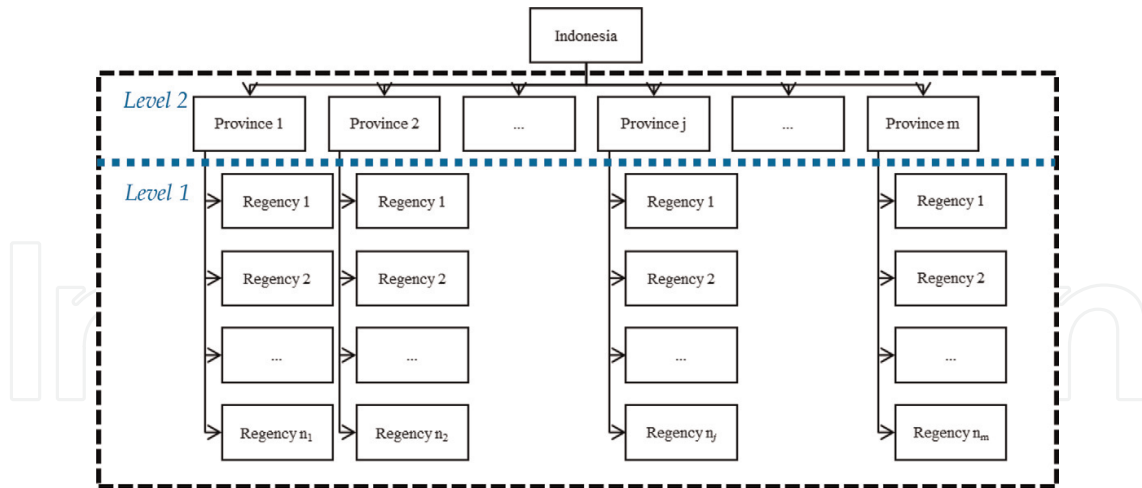

Figure 1. Hierarchical structure scheme.

modeling with the one-level Bayesian approach is to determine the prior distribution for the parameters to be estimated. This study uses an independent prior distribution, i.e., the prior distribution of each parameter is independent of one another. These independent prior distributions can be used to tackle problems in the modeling if it suspects there is high collinearity between the explanatory variables.

Prior distributions are used for each element of the parameter vector in the one-level Bayesian model-based normal distribution as follows:

$$\begin{aligned}
 y_i &= \beta_0 + \beta_1 x_{1i} + \beta_2 x_{2i} + \dots + \beta_p x_{pi} + e_i \\
 \mathbf{y} &\sim N(\boldsymbol{\mu}, \sigma^2 \mathbf{I}), \\
 \boldsymbol{\mu} &= \mathbf{x}\boldsymbol{\beta} + \mathbf{e}, \\
 \tau &= \frac{1}{\sigma^2}, \\
 e_i &\sim N(0, \sigma^2), \\
 \beta_s &\sim N(\hat{\beta}_s, \sigma_s^2), \\
 \sigma_s^2 &\sim \text{Gamma}(a_s, b_s), \\
 &\text{where } i = 1, 2, \dots, n; n \text{ is number of data,} \\
 & \quad s = 0, 1, 2, \dots, p; p \text{ is number of micro predictor variables.}
 \end{aligned} \tag{1}$$

Determining the value of hyper-parameter of each parameter in the prior distribution is done by a combination of the conjugate and pseudo priors [9]. This is done to ensure that the iteration of the parameter estimation process will quickly meet convergence and meet the properties of the Markov chain, i.e., irreducible, aperiodic, and recurrent.

- b. Implement the algorithm into the syntax of WinBUGS and run.

The relationship between data and the prior distribution of parameters in Bayesian modeling can be illustrated as a graphic model form using a directed acyclic graph (DAG).

**Figure 2** is a representation of the relationship among data, model parameters, and their parameter prior being modeled. Box-shaped node is used for representing the parameter or data which are constant, while the node ellipse is used for representing the parameters changing stochastically or as a logical structure relationship. Between nodes is connected by a single line and a dotted line. The single line is stating a stochastic relationship, while the dotted lines express logical relationships.

- c. Analyze the model by listing significant contributions of each predictor variable using the concept of whether the zero value is inside the credible interval of its highest posterior distribution (HPD).
  - d. Measure the accuracy of this general one-level Bayesian model by computing its deviance information criterion (DIC) value.
3. Parameter estimation of the two-level hierarchical structure Bayesian model. The first-level model is for the regency level modeling, and the second-level model is for the province level modeling.
    - a. Write an algorithm to estimate parameters of the two-level hierarchical structure Bayesian model.

The hierarchical model parameter has a multilevel structure, called hyper-parameter. It is in line with the hierarchical design perspective in this problem, i.e., the hierarchy between regency and province. There are two parameters on the first level, namely,  $\beta$  and  $\sigma_y^2$ , and there are two parameters on the second level, i.e.,  $\gamma$  and  $\sigma_s^2$ . For the parameters in the first level,  $\sigma_y^2$  represents the variance of normal error distribution, and  $\beta$  represents the parameters of regression in the micro model, while the parameters in the second level are referred to a hyper-parameter which is a prior distribution of the parameter  $\beta$ . This parameter  $\beta$  will be set as a response in the regression model which is explained by hyper-parameter as a combination of the covariate  $w$  in the macro model.

The following important steps are determining the distribution and hyper-parameter prior for all of the parameters to be estimated. As in the global one-level model, in this two-level modeling, the independent prior distributions are used. Prior distributions

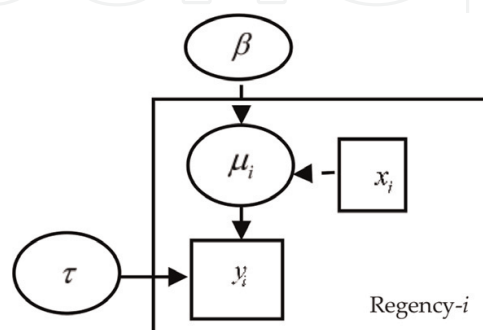

**Figure 2.** DAG one level Bayesian methods.



are used for each element of a Bayesian hierarchical model parameter vector based on the normal distribution as follows:

$$\begin{aligned}
 y_{ij} &= \beta_{0j} + \beta_{1j}x_{1ij} + \beta_{2j}x_{2ij} + \dots + \beta_{pj}x_{pij} + e_{ij}, \\
 \mathbf{Y} &\sim N(\boldsymbol{\mu}_y, \sigma_y^2 \mathbf{I}), \\
 \boldsymbol{\mu}_y &= \mathbf{x}\boldsymbol{\beta} + \mathbf{e}, \\
 \beta_{sj} &\sim N(\hat{\beta}_{sj}, \sigma_{\beta_{sj}}^2), \\
 e_{ij} &\sim N(0, \sigma_y^2), \\
 \hat{\beta}_{sj} &= \gamma_{0s} + \gamma_{1s}w_{1j} + \gamma_{2s}w_{2j} + \dots + \gamma_{qs}w_{qj} + u_{sj}, \\
 \hat{\boldsymbol{\beta}}_j &\sim N(\boldsymbol{\mu}_{\beta_j}, \sigma_{\beta_j}^2 \mathbf{I}),
 \end{aligned} \tag{2}$$

$$\begin{aligned}
 \boldsymbol{\mu}_{\beta_j} &= \boldsymbol{\gamma}\mathbf{w} + \mathbf{u}, \\
 \gamma_{ts} &\sim N(\mu_{\gamma_{ts}}, \sigma_{\gamma_{ts}}^2), \\
 u_{sj} &\sim N(0, \sigma_{\beta_{sj}}^2), \\
 \sigma_{\gamma_{ts}}^2 &\sim \text{Gamma}(a_{\gamma_{ts}}, b_{\gamma_{ts}}), \\
 &\text{where } i = 1, 2, \dots, n_j; j = 1, 2, \dots, m; \\
 &\quad s = 0, 1, 2, \dots, p; \text{ and } t = 0, 1, 2, \dots, q.
 \end{aligned}$$

As in the global one-level model, in this two-level modeling, the determining of the value of each parameter prior distribution is done by a combination of the conjugate and pseudo priors.

- b.** Implement the algorithm into the syntax of WinBUGS and run.

The hierarchical relationship of model parameters, i.e., parameter priors and hyper-parameter prior, in the Bayesian approach of such hierarchical scheme could be described by the directed acyclic graph [10, 11]. Data, parameters, and parameter prior models in the DAG are represented by nodes.

**Figure 3** describes a Bayesian hierarchical model DAG for two-level model based on the normal distribution, i.e., the first level is the regency, and the second level is the provinces. For simplicity of writing, Regency- $i$ ,  $i = 1, 2, \dots, n_j$ , where  $n_j$  is a number of regency in the  $j$ -th province, and Province- $j$ ,  $j = 1, 2, \dots, m$ , where  $m$  is a number of the province. The parameter of regression in the first level is  $\boldsymbol{\beta}$ ; it can be written individually as  $\beta_{sj}$ , where  $s = 0, 1, 2, \dots, p$ ;  $p$  is a number of the covariate in the micro model. While the parameters of regression in the second level is  $\boldsymbol{\gamma}$ , it can be written individually as  $\gamma_{ts}$ , where  $t = 0, 1, 2, \dots, q$ ;  $q$  is a number of the covariate in the macro model.

- c.** Analyze the first and second level model by creating a list of the significant contribution of predictor variables in each regency and province by using the concept of whether the zero value is inside the credible interval of its HPD.

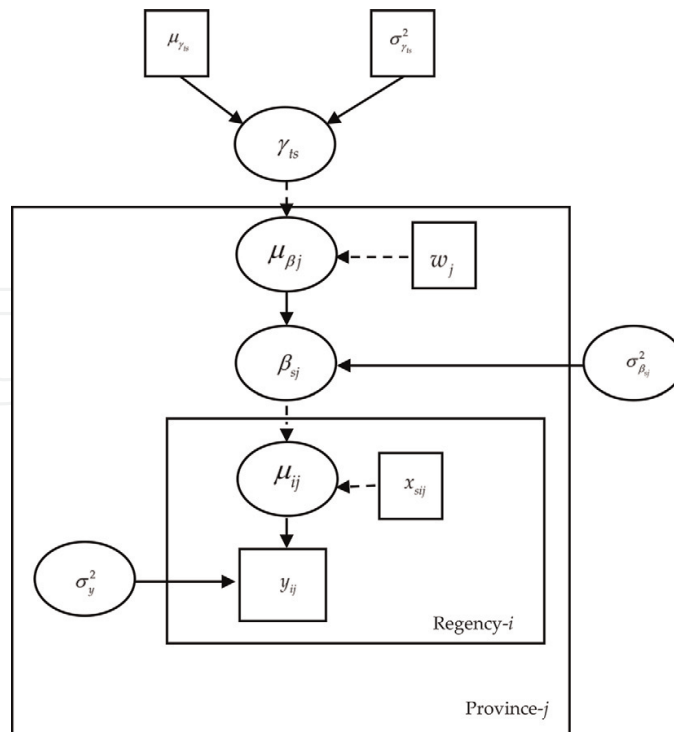

Figure 3. DAG hierarchical Bayesian methods.

- d. Determine the accuracy of this two-level hierarchical structure Bayesian models by computing its DIC value.
4. Choosing the best model between the general one-level Bayesian model and two-level hierarchical structure Bayesian model by comparing their DIC values

The selection of the best models from the two models can use a smaller DIC value. DIC of the  $k$ th model can be determined through the following Equation [11]:

$$\begin{aligned}
 DIC(k) &= 2\overline{D(\theta_k, k)} - D(\bar{\theta}_k, k) \\
 &= D(\bar{\theta}_k, k) + 2p_k
 \end{aligned}
 \tag{3}$$

where  $D(\theta_m, m)$   $D(\theta_k, k)$  is a deviance that is equal to the negative value of twice the log-likelihood as stated in Eq. (4):

$$D(\theta_k, k) = -2 \log f(y|\theta_k, k)
 \tag{4}$$

where  $\overline{D(\theta_k, k)}$  is the average posterior and  $p_k$  represents the number of parameters in the  $k$ th model calculated as

$$p_k = \overline{D(\theta_k, k)} - D(\bar{\theta}_k, k)
 \tag{5}$$

$\bar{\theta}_k$  is average posterior of the parameter in the  $k$ th model. The better model has smaller deviance value.



5. Draw a thematic map that plots the distribution of economic growth of the regency to provinces.
6. Make an interpretation of the results of the modeling; then write conclusions and suggestions.

### 3. Characteristics of research variable

A hierarchical linear model is a regression modeling that can accommodate a hierarchical data structure. The predictor variables were prepared at all predefined levels, while the response variable was measured at the lowest level [10, 12]. The hierarchical structure model could be established by two levels of models, i.e., the micro models (model at the first level) and macro models (model at the second level). Micro models could be in the form of distribution of data in the first level or the regression model between the observed response and predictor in the first level. Macro models, on the other hand, are usually as the regression model between the parameter of the distribution or the regression coefficients from micro models and the predictor variables measured on the second level [13]. In this case, predictor variables measured in the first level were financial credit distributions, i.e., 17 major economic sectors in the regency, while in the macro modeling, variables related to the provincial level were employed. There are six economic sectors that have the greatest contribution among the 17 major economic sectors at the regency level to economic growth, i.e., trade ( $x_7$ ), manufacturing industry ( $x_4$ ), construction ( $x_6$ ), agriculture ( $x_1$ ), transportation, warehousing and communication ( $x_9$ ), and accommodation, food, and beverage services ( $x_8$ ). At the provincial level, for the variable component macro model, on the other hand, they are inflation ( $w_1$ ), interest rates on loans ( $w_2$ ), deposits ( $w_3$ ), and the ratio of the nonperforming loan (NPL) ( $w_4$ ).

The distribution of the response variable has to be determined in order to build the likelihood distribution which will be applied in both general one-level Bayesian and hierarchical structure Bayesian approach. To do so, the goodness of fit (GOF) test has to be done to check the suitability of the selected hypothetical distribution pattern with the distribution of the observed data. In this study, the null hypothesis of “the response data follow a particular distribution pattern” would be tested to the alternative hypothesis of “the response data do not follow a particular distribution pattern” by using the Anderson-Darling (AD) test [14]. Eq. (6) represents the AD test statistic:

$$W_n^2 = -n - \frac{1}{n} \sum_{j=1}^n (2j-1) [\log u_j + \log (1 - u_{n-j+1})], \quad (6)$$

where  $n$  is the number of observed sample units and  $u_j$  is the cumulative distribution function at the data observations. The null hypothesis would be rejected when  $W_n^2$  is greater than a critical value,  $c_\alpha$  [15], calculated as Eq. (7):

$$c_\alpha = a_\alpha * \left( 1 + \frac{b_0}{n} + \frac{b_1}{n^2} \right), \quad (7)$$

where at the significance level  $\alpha = 5\%$ , the value for  $a_\alpha = 0.7514$ ,  $b_0 = -0.795$ , and  $b_1 = -0.890$  [15]. In this study, the response data was tested whether the pattern was normally distributed or not by using the following hypothesis test.

$H_0$ : The economic growth distribution fits the normal distribution.

$H_1$ : The economic growth distribution is unfit for the normal distribution.

Results of the GOF test by using the AD test show that the economic growth (response variable) of the selected 11 provinces follows the normal distribution. The Bayesian normal-based approach employing the likelihood of normal distribution, therefore, is applicable for this case.

#### 4. Indonesia's economic growth modeling using general one-level Bayesian methods

In the general one-level Bayesian modeling for economic growth, it must begin with the assumption that all regencies in the 11 selected provinces have the same level of economic

Parameter	Mean	MC error	2.50%	Median	97.50%
$\beta_0$	5.54400	8.16E-04	5.26400	5.54400	5.825000
$\beta_1$	-0.24950	0.001269	-0.66500	-0.24940	0.165100
$\beta_2$	0.03708	0.001033	-0.29370	0.03742	0.363600
$\beta_3$	0.01071	0.001133	-0.38670	0.01121	0.413800
$\beta_4$	-0.02010	0.001788	-0.65760	-0.01853	0.621500
$\beta_5$	-0.30450	9.90E-04	-0.61510	-0.30430	0.004251
$\beta_6$	0.13530	0.003614	-1.17600	0.13380	1.468000
$\beta_7$	0.32110	0.003616	-0.90150	0.32280	1.523000
$\beta_8$	0.88960	0.003478	-0.40340	0.88640	2.198000
$\beta_9$	-0.36810	0.003282	-1.41100	-0.36580	0.674800
$\beta_{10}$	-0.26800	0.002072	-1.00700	-0.26790	0.461900
$\beta_{11}$	-0.36240	0.003382	-1.49700	-0.36450	0.802700
$\beta_{12}$	0.25370	9.14E-04	-0.06085	0.25490	0.570000
$\beta_{13}$	-0.60620	0.002666	-1.58900	-0.60710	0.373700
$\beta_{14}$	0.14230	0.001768	-0.48590	0.13990	0.778100
$\beta_{15}$	-0.01639	0.004265	-1.53900	-0.01792	1.531000
$\beta_{16}$	0.37940	0.002525	-0.51430	0.37870	1.274000
$\beta_{17}$	-0.58840	7.76E-04	-0.89230	-0.58780	-0.288300
$\tau$	0.15720	9.57E-05	0.13160	0.15660	0.185300

**Table 1.** Significance testing parameters of one-level Bayesian model.

growth. All of the 17 variables were employed to model simultaneously and give the general one-level Bayesian model as Eq. (8):

$$y = 5.544 - 0.2495x_1 + 0.03708x_2 + 0.01071x_3 - 0.0201x_4 - 0.3045x_5 + 0.1353x_6 \\ + 0.3211x_7 + 0.8896x_8 - 0.3681x_9 - 0.268x_{10} - 0.3624x_{11} + 0.2537x_{12} - 0.6062x_{13} \quad (8) \\ + 0.1423x_{14} - 0.01639x_{15} + 0.3794x_{16} - 0.5884x_{17}$$

The next step is to test the parameter significance of this one-level Bayesian model using credible intervals. If the credible interval does not hold zero, then the estimated parameter is significant. The result shown in **Table 1** says that the intercept and the financial credit distribution of international agencies and other extra-national agencies sector to total loans ( $x_{17}$ ) have a significant influence to their economic growth, but the other 16 variables are insignificant. The insignificance of the 16 variables means that the contribution of these 16 variables is not statistically influential enough for economic growth in each regency, but those sectors cannot be interpreted that they should not be implemented in every regency to support their economic growth. This insignificance can be caused by the random nature of each sector's activities among regions, where, naturally, it should be varied locally, but in this modeling, it is treated and considered to be all the same and global for all regions, to the response variable.

## 5. Indonesia's economic growth modeling using hierarchical structure Bayesian methods

Two regression models would be established in this hierarchical structure Bayesian approach, i.e., a regression model for the micro model (first level) and macro model (second level), respectively. The regression model in the first level will use 17 variables, and it has to estimate 198 parameters, while the regression model in the second level will use 4 variables, and therefore, it has to estimate 90 parameters. **Table 2** shows six estimated parameters of 18 regression coefficients in micro models for selected six provinces.

Parameter	Aceh	West Java	Central Java	East Java	South Sulawesi	Southeast Sulawesi
$\beta_0$	4.0630	4.3330	4.92000	3.0330	6.3470	4.741
$\beta_1$	-0.1328*	-1.0220*	0.28610*	-0.0955*	3.3370*	-2352.000
$\beta_2$	-1.9210*	0.0192*	-0.00404*	-0.2382*	0.0821*	-981.200
$\beta_3$	-37.4500*	-0.8488*	0.86100*	-1.5820	-14.8400*	-39.940
$\beta_4$	-174.6000	-0.3119*	-0.23360*	0.3850*	3.0480*	-1023.000
$\beta_5$	8.6950*	-0.3027	0.40700*	0.9209*	-0.5125*	-340.000

\*The estimated parameter was not significant at  $\alpha = 5\%$ .

**Table 2.** Six estimated parameters of 18 regression coefficients in micro models for selected six provinces.

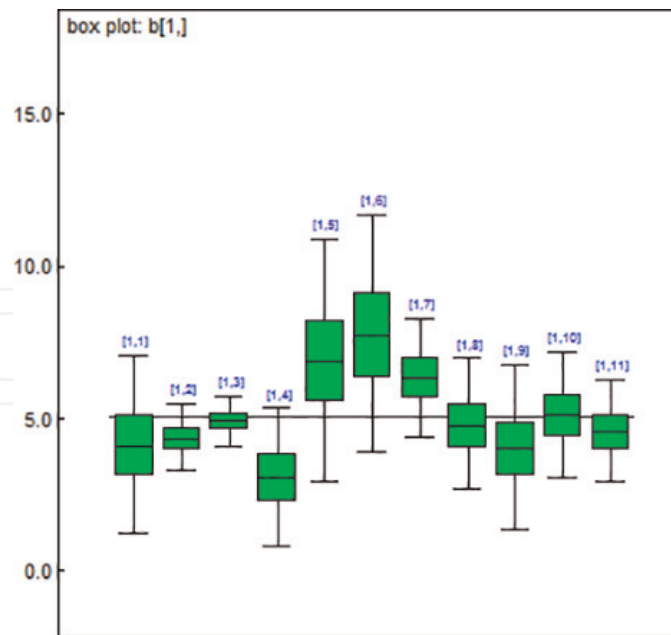

Figure 4. Boxplot of intercept micro models.

Table 2 demonstrates that each estimated  $\beta_i$ ,  $i = 0, 1, \dots, 5$  is treated as variables, i.e., the values of  $\beta_i$  among provinces were different. This also applies to  $\beta_i$ ,  $i = 6, 7, \dots, 17$ . As an example, in the intercept coefficient, the lowest belonged to the East Java Province, while the greatest value belonged to Papua Province. These intercept variations of selected 11 provinces in micro models are presented as boxplot in Figure 4. This fluctuation of these parameters would be explained by regressing these parameters to the four covariates in the second level. This has to be done to find out the different effects of their different local policies in implementing their provincial regulations when it is viewed from differences of parameter values [12, 16]. This stage of regression is applied to each random resulted regression parameter of the first level to the covariate at the second level. Table 3, as an example, shows only 6 of 18 regressions of macro model. Combining this cross-level interaction hierarchically between micro and macro models, the model of Aceh province, for example, for the randomly intercept only, can be written as Eq. (9):

$$\begin{aligned}
 y_1 = & (5.059 + 1.037w_1 + 0.2406w_2 - 1.605w_3 + 1.153w_4) - 0.1328x_1 \\
 & - 1.921x_2 - 37.45x_3 - 174.6x_4 + 8.695x_5 - 11.91x_6 - 0.5904x_7 \\
 & - 2.461x_8 - 74.23x_9 + 111.7x_{10} + 238.3x_{11} - 115.1x_{12} - 50.71x_{13} \\
 & + 22.8x_{14} + 11.58x_{15} + 0.1152x_{16} - 1.606x_{17}
 \end{aligned} \tag{9}$$

From the example of a hierarchical model for Aceh, a hierarchical structure model can demonstrate its superiority in presenting a new model as a hierarchical cross-level interaction through the modeling of the slope of micro models. This model can describe the differences in economic growth between different provinces even though they have characteristics of regencies with almost perfect similarities. In this case, the role of provincial characteristics is as an activator variable in relation to the regency's economic growth rate. The interpretation, therefore, could

Parameter in micro model	$\gamma_0$	$\gamma_1$	$\gamma_2$	$\gamma_3$	$\gamma_4$
$\beta_0$	5.0590	1.0370*	0.2406*	-1.6050*	1.1530*
$\beta_1$	4.7120E+04	-4.6160E+04	365.3001	9.610E+03	-6.1450E+04
$\beta_2$	9.9490E+05	9.6220E+05	-7.2320E+05	-2.9160E+05	-7.3050E+05
$\beta_3$	-7.4470E+04	-2.37E+05	1.5040E+05	7.2280E+04	-5.163E+03
$\beta_4$	-4.0340E+05	3.4290E+05	4.6780E+04	-3.5150E+04	4.8380E+05
$\beta_5$	1.0480E+04	-1,28E+05	3.4670E+04	2.9410E+04	-5.1220E+04

\*The estimated parameter was not significant at  $\alpha = 5\%$ .

**Table 3.** Summary of parameter estimation macro model regression.

be derived from the micro models adapted to the characteristics of each province. In addition, the creation of predictors by adding depth to the hierarchical level will be more adaptive in capturing real phenomena in the field.

The results in the first line of **Table 2** and **Figure 4** showed that the intercept of micro models varies among the provinces. It is due to the significant effect of the province characteristics as shown by the first line of **Table 3**. All of the estimated parameters of the covariate  $w$  in the second level,  $\gamma_t$ ,  $t = 0, 1, 2, \dots, q$ , are significant, except for  $\gamma_0$ . This means that variables in the second level, inflation ( $w_1$ ), interest rates on loans ( $w_2$ ), and NPL ratio ( $w_4$ ), are affecting the different shifts in economic growth in each regency. Interpretation for parameters other than intercepts can be done in the same way, namely, by substituting the results of parameter estimates at level two in **Table 3** of the second row into the first-level model.

## 6. The best model selection

Modeling of economic growth in Indonesia in this study is done using two methods, the general one-level Bayesian and the two-level hierarchical structure Bayesian models. These two models would be compared to see which model is a more representative model to economic growth. The main point of view that needs to be highlighted in the modeling differences is that in general one-level Bayesian modeling, all of the characteristics at the provincial level are ignored and only the characteristics in the Regency are considered. In this modeling view, the economic growth in all regencies was, therefore, treated equally. The Bayesian hierarchical structure modeling, on the other hand, was smartly joining the

Model	DIC
General one-level Bayesian	1351.360
Hierarchical structure Bayesian	916.490

**Table 4.** Goodness-of-fit model.



characteristics at the provincial level and at the regency level. Here, the economic growth could be explained as a cross-level interaction hierarchically through the modeling of parameters of micro models to the province characteristics as its covariates. The criteria used to select the best model are the value of DIC. Based on the smaller DIC in **Table 4**, the hierarchical structure Bayesian model was better than the general one-level Bayesian model.

## 7. Thematic map of economic growth in Indonesia

The economic growth of each regency based on the one-level Bayesian method can be seen in **Figure 5**. Each color in **Figure 5** represents economic growth in a regency. Color code 64 is a color code for the regency that is not included in the modeling. The higher the economic growth in a region, the greater the color code. Nabire has the highest economic growth in 2015 among other regencies in Indonesia, i.e., 9.51%, so the color code for Nabire is 255.

Furthermore, the thematic map of economic growth of each regency based on the hierarchical Bayesian method shown in **Figure 6**, where the color codes for regencies that are not included modeling is code 83. Like a thematic map of economic growth based on the one-level Bayesian method, these maps also show that the higher the economic growth in a region, the greater the color code.

Based on **Figures 5** and **6**, the difference between economic growth modeling using the global one-level Bayesian method and the hierarchical Bayesian method is easily seen. The difference is the color in **Figure 5** only influenced by covariates of regencies, whereas the difference in

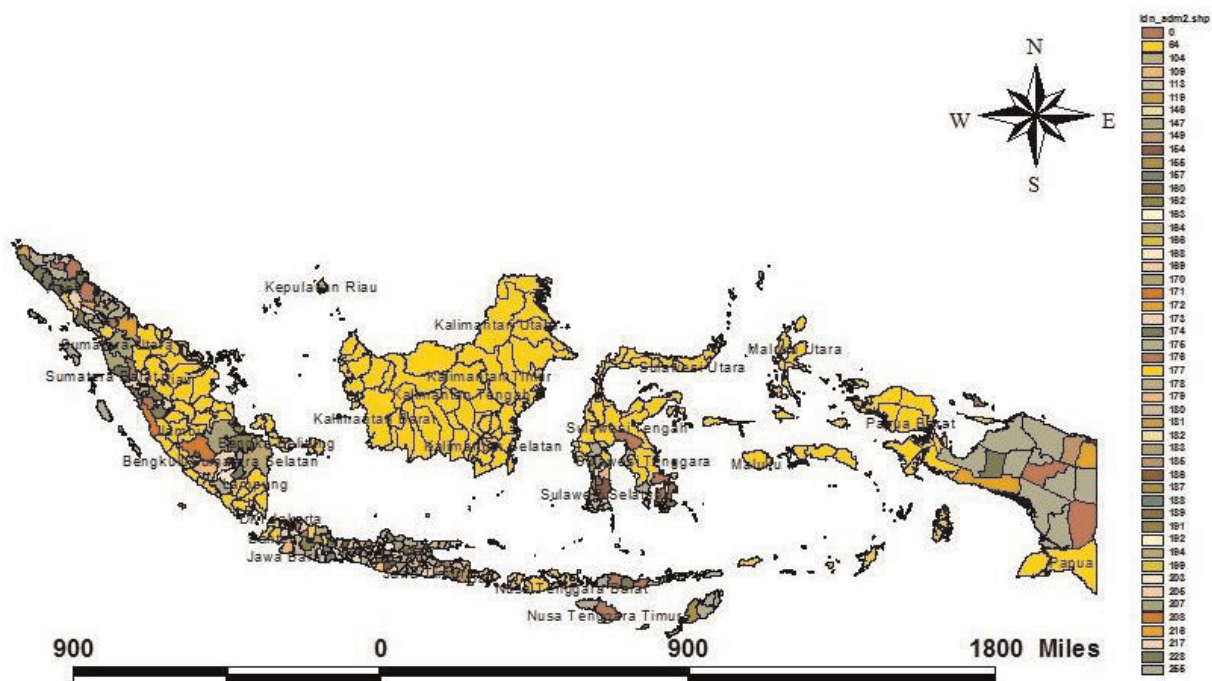

Figure 5. Thematic Map One-Level Bayesian Model.



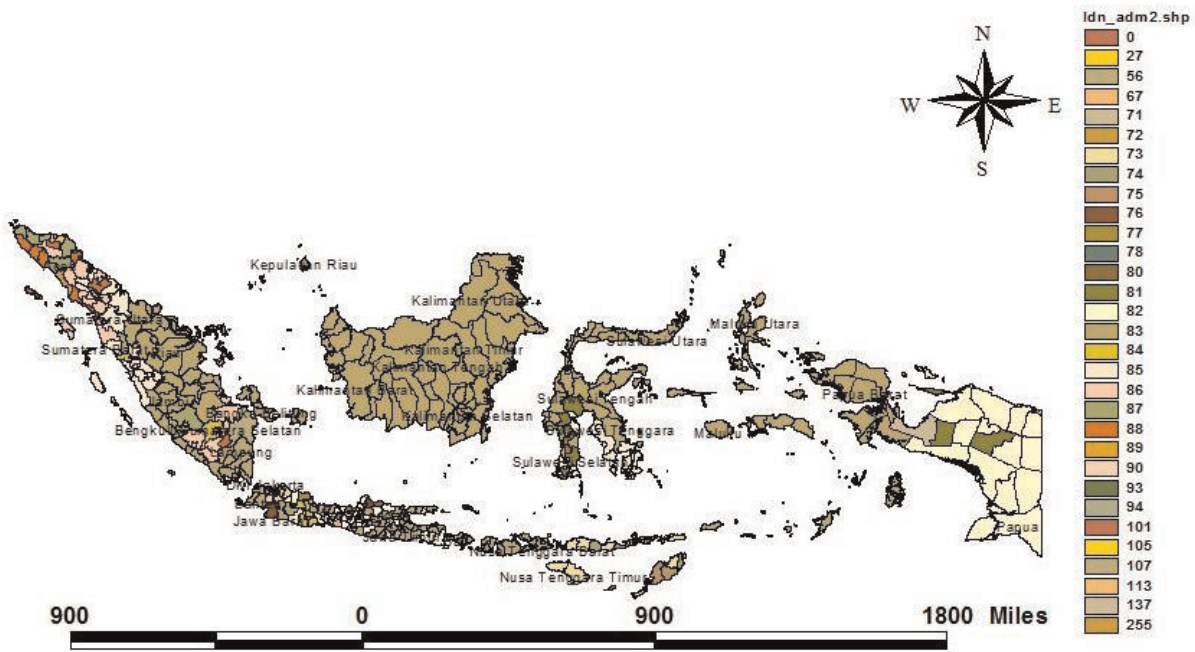

Figure 6. Thematic Map Hierarchical Bayesian Model.

color in **Figure 6** is due to the collaboration and interaction between covariates in each regency and province. In addition to this, collaboration and interaction of the characteristics of the regency and province also affect the color difference in maps. Hierarchical Bayesian model is better in representing the economic growth in each regency in Indonesia, as has been discussed in Section 6. **Figure 6** looks more clear in describing and representing Indonesia’s economic growth in 2015.

## 8. Conclusion

Some conclusions could be gathered, i.e., (i) the economic growth model based on financial credit distribution in Indonesia generally follows the normal distribution pattern, (ii) it would be more appropriate to be modeled using the hierarchical Bayesian than using a global one-level Bayesian method, and (iii) the results of hierarchical Bayesian modeling can also be seen as a significant influence on the regression coefficients that describe a cross-level interaction of the regency and provincial characteristics. The influence of the regency characteristics, therefore, cannot be generalized, so that the regency characteristics should be fitted to the province characteristics.

There were also some recommendations to be given, i.e., (i) the local government and Bank Indonesia should focus on addressing issues of inequality of economic growth in Indonesia, especially in areas with slow rate of economic growth; and (ii) it was necessary to develop a new method that (a) was capable to include the provinces with the regency number of less

than 17 variables in the model and (b) was able to model the different distribution patterns of economic growth in the different regions into the generalized hierarchical Bayesian model.

## Acknowledgements

We would like to express our gratitude to the anonymous reviewers for the criticism and suggestions for the improvement of this research and to IntechOpen for sponsoring the publication of this article.

## Author details

Nur Iriawan\* and Septia Devi Prihastuti Yasmirullah

\*Address all correspondence to: [nur\\_i@statistika.its.ac.id](mailto:nur_i@statistika.its.ac.id)

Department of Statistics, Faculty of Mathematics, Computing, and Data Science, Institut Teknologi Sepuluh Nopember, Indonesia

## References

- [1] Todaro MP, Smith SC. Economic Establishment (Originally: Pembangunan Ekonomi). Jakarta: Erlangga; 2006
- [2] Statistics Indonesia. Gross Domestic Product. Available from: <https://www.bps.go.id/Subjek/view/id/11>
- [3] United Nations Development Programme (UNDP). Converging Development Agendas: Nawacita, RPJMN, and SDGs. Available from: <http://www.id.undp.org/content/dam/indonesia/2015/doc/publication/ConvFinal-En.pdf>
- [4] Otoritas Jasa Keuangan. Potential Economic Growth. Available from: [http://www.ojk.go.id/id/berita-dan-kegiatan/publikasi/Documents/Pages/Potensi-Pertumbuhan-Ekonomi-ditinjau-dari-Penyyaluran-Kredit-Perbankan-Kepada-Sektor-Prioritas/Kajian%20Kredit%20-%20Pertumbuhan%20Eko%20\(final\).pdf](http://www.ojk.go.id/id/berita-dan-kegiatan/publikasi/Documents/Pages/Potensi-Pertumbuhan-Ekonomi-ditinjau-dari-Penyyaluran-Kredit-Perbankan-Kepada-Sektor-Prioritas/Kajian%20Kredit%20-%20Pertumbuhan%20Eko%20(final).pdf)
- [5] Levine R. Legal environment, bank, and long-run economic growth. *Journal of Money, Credit and Banking*. 1998;**30**:596-613. DOI: 10.2307/2601259
- [6] Rajan R, Zingales L. Financial dependence and growth. *The American Economic Review*. 1998;**55**:559-586. DOI: 10.3386/w5758
- [7] Soedarmono W, Hasan I, Arsyad N. Non-linearity in the finance-growth nexus: Evidence from Indonesia. Working Paper. 2015. pp. 2-17. DOI: 10.1016/j.inteco.2016.11.003

- [8] Raudenbush SW, Bryk AS. Hierarchical Linear Models. Thousand Oaks: Sage Publications; 2002
- [9] Yasmirullah SDP, Iriawan N, Sipayung FR. An economic growth model based on financial credits distribution to the government economy priority sectors of each regency in Indonesia using hierarchical Bayesian method. AIP Conference Proceedings. 2017;1905. DOI: 10.1063/1.5012264. ISBN: 978-0-7354-1595-9
- [10] Boldstad WM. Introduction to Bayesian Statistics. New Jersey: Wiley; 2007
- [11] Ntzoufras L. Bayesian Modeling Using WinBUGS. New Jersey: John Wiley & Sons Inc; 2009
- [12] Ismartini P, Iriawan N, Setiawan S, Ulama BSS. Toward a hierarchical Bayesian framework for modelling the effect of regional diversity on household expenditure. Journal of Mathematics and Statistics. 2012;8:283-291
- [13] Iriawan N. Modelling and Data-Driven Analysis. Vol. I. Surabaya: ITS Press; 2012
- [14] Anderson T, Darling D. Asymptotic theory of certain goodness of fit criteria based on stochastic process. The Annals of Mathematical Statistics. 1952;23(2). DOI: 10.1214/aoms/1177729437
- [15] Ang A, Tang W. Probability Concepts in Engineering. New York: Wiley; 2007. pp. 289-396
- [16] Wirawati I, Iriawan N, Irhamah. Bayesian hierarchical random intercept model based on three parameter gamma distribution. Journal of Physics: Conference Series. 2017;855: 012061. DOI: 10.1088/1742-6596/855/1/012061