

# We are IntechOpen, the world's leading publisher of Open Access books Built by scientists, for scientists

**4,800**

Open access books available

**122,000**

International authors and editors

**135M**

Downloads

Our authors are among the

**154**

Countries delivered to

**TOP 1%**

most cited scientists

**12.2%**

Contributors from top 500 universities



**WEB OF SCIENCE™**

Selection of our books indexed in the Book Citation Index  
in Web of Science™ Core Collection (BKCI)

Interested in publishing with us?  
Contact [book.department@intechopen.com](mailto:book.department@intechopen.com)

Numbers displayed above are based on latest data collected.

For more information visit [www.intechopen.com](http://www.intechopen.com)



# F-diagram Research Method for Double Circuit Solar System with Thermosyphon Circulation

*Yedilkhan Amirgaliyev, Murat Kunelbayev,  
Aliya Kalizhanova, Ainur Kozbakova, Salauat Daulbayev,  
Timur Merembayev and Didar Yedilkhan*

## Abstract

In the work herein we have conducted researches of F-diagram method for the solar system with thermosyphon circulation-diagram method is based on correlation of a lot of simulations, computed non-dimensional variables. Modeling conditions varied in corresponding ranges of thermosyphon circulation double circuit solar system practical constructions' parameters. By means of F-diagram method there have been computed the environmental monthly temperature values with correction index, which shows that the monthly average daily heating degree and direct solar radiation decrease according to weather conditions. It may be noted that monthly temperature load fraction increases along with the collector square growth. It demonstrates that the monthly temperature load fraction is higher in summer in Almaty city (Kazakhstan) (July—the highest value) and lower in winter months (January, February—the lowest value).

**Keywords:** flat solar collector, F-diagram method, environmental temperature, solar radiation, double circuit solar system, thermosyphon circulation

## 1. Introduction

Solar radiation and environmental temperature measuring represent a complicated problem, as it includes unpredictable weather conditions for designing the solar system heating, which involves solar system components' dimensions exact defining. There are three categories considered upon solar heating systems designing. The first category belongs to the system, in which the collector's working temperature is known or it might be assessed, for which radiation critical levels can be revealed.

The second category is based on the big amount of detailed simulations and presents the F-diagram method.

The third category includes the short circuit simulation, in which the modeling is fulfilled by means of meteorological data for representative days and it is called the sol cost method [1].

In this experiment [2], eight typical Taiwanese solar water heaters, which were connected in series, were considered. The degree of temperature stratification and

consumption of thermosyphon in a horizontal tank is estimated. The system was tested without load, with interruptions and constant load conditions. The results showed that stratification of the state was observed in tanks under load.

The researchers compared the gap filler in the results on the scale of complexity in the simulation program from the programs F-diagrams [3].

In the study [4], referring to the method of F-diagrams calculated coefficient of thermal characteristics of the solar collector.

Usage of F-diagram method for active premises heating systems applying the working liquid is the thermal research basis [1]. Applying this method thereof we can assess the fraction of total heating load, which can be provided by the solar energy system. In the method the primary project variable is a collector's square, and the secondary variables are accumulator capacity, collector type, dimensions of heat exchanger load and collector and liquid flow speed. F-diagrams have been developed for three system standard configurations: liquid and air, used for premises heating (and hot water) and systems for only hot water [1]. In this study [5], solar systems are analyzed using the F-chart method in order to satisfy the hot water needs of hotels. The annual fraction and heat loads for different solar collector's area and number of people is estimated. Flat plates and vacuum tube collectors are compared and analyzed.

Kalogirou used for protection from freezing water ethylene glycol, necessary for solar heating system operation [6].

In order to assess the solar energy potential, falling onto the territory in any region, it is necessary to have data on the solar energy potential. Based on actual observations and theoretical computations generalization we can obtain the following data: annual and latitudinal movement of potential monthly and annual sums of direct solar radiation, falling onto the perpendicular surface under the clear sky conditions; the data on sun shine duration; sunshine daily move; radiation for the annual typical days; maps of distributing the average monthly radiation amounts for June and December on Kazakhstan territory [7].

In the article herein, using the F-diagram method, the authors have designed the solar heating system and definition of total thermal load fraction (load on household water and heating), which will be supplied with solar energy with a view to the family, consisting of six people in Almaty city. The research includes the influence of the collector's different squares and storage capacity per the collector square meter and collector tilter the load share, maintained by the solar energy. As well, there will be studied an annual behavior of solar load share and monthly load change within a year.

## **2. System description**

System's standard configuration, used in the given work frame, to which the F-diagram method will be applied, has been shown on the **Figure 1**. The system herein makes use of the liquids (commonly, water or antifreeze solution) as a heat carrier and water as a storage medium [5]. Flat solar collectors with thermosyphon circulation are used for transforming the falling solar radiation into the thermal heat. The energy thereof is accumulated in the form of notable heat in the tank for the liquid storage and used, when the need arises, to provide premises and water heating.

Proposed system operation is executed as follows (**Figure 1**). The solar energy  $E$  with temperature  $t_0$  is absorbed by solar collector (1) with temperature  $t_1$ , heating the flow, the solar energy moves through a translucent insulating glazing unit (2). The heat, received from the solar stream, heats the liquid in coils (3), which is

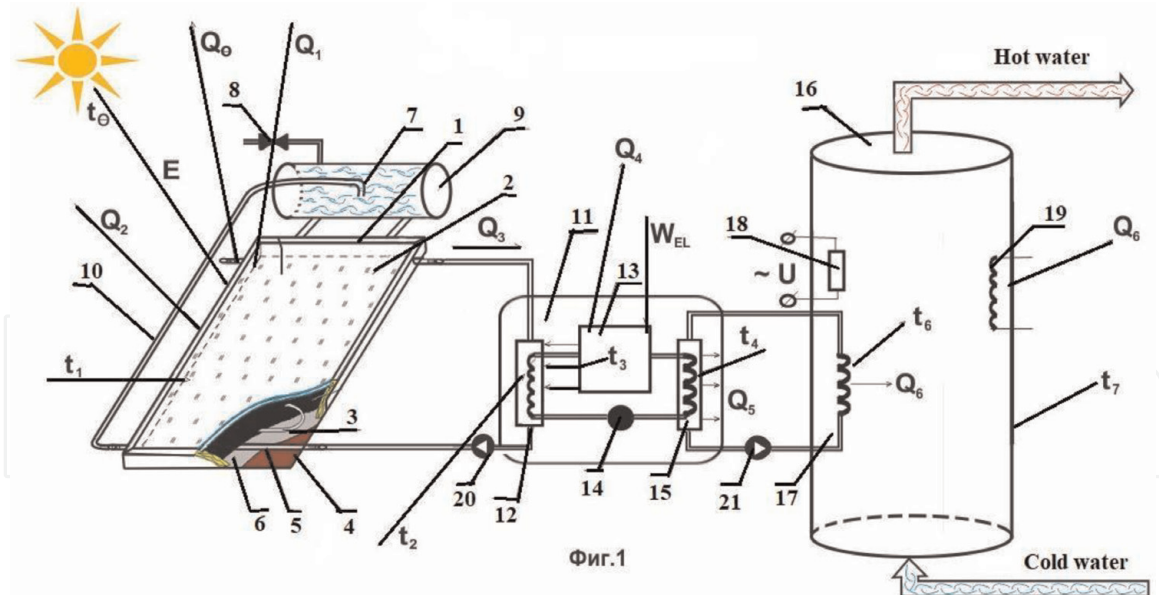
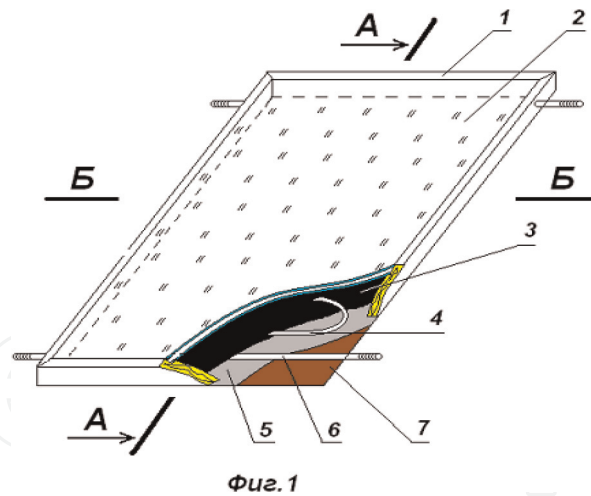

**Figure 1.**  
 Principal diagram of double circuit solar installation with thermosyphon circulation.

removed from a collector, and instead of it there incomes cold water from the water pipeline with a valve for cold water (8) and from the syphon of a dosimeter tank (7) there takes place constant thermosyphon circulation by means of circulation tube (10). Further the liquid enters a thermal pump (11), which consists of a condenser evaporator (12) with temperature  $t_2$ , with a heat exchanger in the form of a spiral, absorbing the heat carrier heat, lowers its temperature down the atmospheric temperature ( $Q_2$ ) using the speed control valve (14), thereby serving to the heat additional absorption from the atmospheric air. The scheme also shows the solar irradiation, reflected from semi translucent cover ( $Q_0$ ) and an absorbing panel surface ( $Q_1$ ). In the thermal pump there is fulfilled a heat exchanger energy transfer, at respectively low temperature, to a condenser heat exchanger's heat carrier (15) in the form of a spiral with higher temperature  $t_2$ , which increases the square, as well, a heat exchanger intensity. To execute the cycle thereof we use a compressor (13) with temperature  $t_3$ , with an electric drive (17). Hereafter, by means of a condenser heat exchanger (15) with temperature  $t_4$ , the heat from a thermal pump ( $Q_5$ ) is transferred to a heat exchanger's accumulator tank  $Q_6$  with temperature  $t_6$  of the heating system (18). As the installation has two circuits, it is provided with automatic circulation pumps (19, 20) for liquid circulation between the solar collector and evaporator, condenser and accumulator tank. The water temperatures brought to the demanded technological level and supplied to a consumer for water provision and heating.

**Figure 2** demonstrates the model of the flat solar collector. The main point and novelty is in the fact that in distinction from the known designing principle, the collector contains a translucent glazing unit (2) with double glass and reduced pressure, as well as a parametric frame (1). A wooden frame's bottom (7) has been made of plywood with 8 mm thickness and stuck a heat sealing film (5) with foil. In the gap between a glazing unit and frame's bottom there has been laid a flexible  $4\phi 16$  mm thin walled stainless corrugated pipe in the coil form. Pipe edges are attached to the inlet and outlet protruding tubes (6) (**Table 1**).

**Figure 3** shows a flat solar collector's mockup. The solar collector is the main heat generating unit of the solar installation. To reach a preset aim we have developed a principally new flat solar collector, based on which there will be constructed various types solar installations, used for water heating and buildings and premises heating.



**Figure 2.**  
Flat solar collector.

Parameters	Value
Absorbing plate material	Copper
Absorbing plate dimensions	2 m × 1 m
Plate thickness	0.4 mm
Glazing material	Hardened glass
Glazing dimensions	2 m × 1 m
Glazing thickness	4 mm
Insulation	Foam plex (foam polyurethane)
Collector tilt	45°
Absorber's heat transmission capacity	401 W/(m K)
Insulation heat transmission capacity	0.04 W/(m K)
Transmission-absorption factor	0.855
Sun visual temperature	4350 K
Atmospheric temperature	303 K
Radiation intensity	1000 W/m <sup>2</sup>

**Table 1.**  
Technical specifications of flat solar collector.

**Table 2** represents the ranges of the basic project variables, used upon developing the correlations for liquid solar system heating [1].

The authors have elaborated a new computation methodology and selection of thermosyphon solar collector's geometrical parameters. As well, there has been shown the dependence of the tube's cross section on the flow time for different pressure values. Along with the syphon head increase there the liquid flow time grows as well. It is explained with the fact that the syphon hydraulic resistance increases along with pressure increase, which brings to the liquid speed reducing. For the first time there has been formulated the dependence, defining the fluid discharge time according to the solar collector's geometrical parameters. The methodology, having been elaborated, has allowed stating that the local hydraulic resistance and friction play a sufficient role in a heat carrier's expenditures [8]. Also we have considered the mathematical model of separate constructions and operation





**Figure 3.**  
 Mockup of flat solar collector.

Parameter	Range
$(\tau\alpha)_n$	0.6–0.9
$F'_{RA_C}$	5–120 m <sup>2</sup>
$U_L$	2.1–8.3 W/m <sup>2</sup> *K
$\beta$ (collector slop)	30–90°
$(UA)_h$	83–667 W/K

**Table 2.**  
 Construction parameters ranges used upon developing F-charts for liquid systems [5].

mode of thermosyphon circulation double circuit solar collector. Proceeding from the analysis results we have managed to optimize individual structural elements, as well to prognoses the thermal regime and alternative solutions selection for designing the flat solar collectors and their operation regime selection [9].

### 3. F-chart method

Solar heat supply system's energy balance for the month period can be presented as [1]:

$$Q = Q_{h.ws} + E = \Delta U \quad (1)$$

where  $Q$  is the solar installation monthly heat production,  $Q_{h.ws}$  is the hot water supply monthly load,  $E$  is the energy total amount, obtained within a month, and  $\Delta U$  is the energy amount change in the accumulating unit.

At dimensions of accumulators, commonly used in the solar water supply systems, the difference  $\Delta U$  is small comparing to  $Q$ ,  $Q_{h.ws}$  and  $E$  and can be adopted as equal to zero. Then Eq. (1) can be presented in the form of [1].

$$f = \frac{Q_{h.ws} - E}{Q_{h.ws}} = \frac{Q}{Q_{h.ws}} \quad (2)$$

where  $f$  is the fraction of the monthly thermal load, provided at the solar energy expense.

Straightforwardly, Eq. (2) cannot be used for computing  $f$ , as the value  $Q$  is the function of the falling radiation, environmental temperature and thermal loads. However, consideration of the parameters, the  $Q$  is dependent on, allows supposing, that the replacement rate of it can be empirically linked with two dimensionless complexes [1].

$$X = F_k K_k (T_a - T_b) \frac{\Delta t}{Q_{h.ws}} \quad (3)$$

$$Y = \frac{F_k \eta_0 E_k n_d}{Q_{h.ws}}, \quad (4)$$

where  $T_a$  is basic temperature, accepted as equal to  $100^\circ\text{C}$ ,  $T_b$  is the average monthly temperature of outside air,  $^\circ\text{C}$ ,  $\Delta t$  is the time change, and  $E_k$  is the average monthly daily incoming of the total solar radiation falling onto the flat collector's inclined surface,  $\text{J}/(\text{m}^2 \cdot \text{day})$ .

F-diagram method is based on correlation of many simulations in terms of easily computed dimensionless variables. Modeling conditions varied in the corresponding ranges of the system's practical constructions parameters. Resulting correlations give to  $f$  the fraction of monthly heating load (in the case herein—the premises heating and hot water), provided with the solar energy, as the function of two dimensionless parameters. One of them is linked with the ratio of collector losses to the thermal loads ( $X$ ), another—the ratio of the absorbed solar radiation to the thermal loads  $Y$ . Proceeding from the systems simulation, where was used the F-diagram, it has become possible to develop the correlation between dimensionless variables and  $f$ —monthly load fraction, transmitted by the solar energy. Dimensionless parameters  $X$  and  $Y$  are defined as follows [1]:

$$X = \frac{\text{Collector energy loss during a month}}{\text{Total heating load during a month}} \quad (5)$$

$$Y = \frac{\text{Absorber solar radiation}}{\text{Total heating load during a month}} \quad (6)$$

Parameters  $X$  and  $Y$  can be recorded as in Eqs. (3) and (4), respectively.

$$X = \frac{A_C F' U_{L(T_{ref} - T_a)} \Delta \tau}{L} \quad (7)$$

$$Y = \frac{A_C F' R(\tau \alpha) \overline{H} N}{L} \quad (8)$$

To simplify the computations the dimensionless parameters values  $X$  and  $Y$  in Eqs. (3) and (4) are usually placed as in the equations [1], respectively. The reason for the arrangement thereof consists in the fact that coefficients values ( $LR$   $UF$  and

n RF) are obtained from the results of the standard collector testing. The ratios  $F'R/FR$  correct various temperature gradients between collector and storage tank and they are computed with the techniques, generalized in [1]. The ratio  $(\tau\alpha)/(\tau\alpha)_n$  is as well assessed with the techniques, given in [1].

$$X = F_R U_L \frac{F'/R}{F_R} (T_{ref} - T_a) \Delta\tau \frac{A_C}{L} \quad (9)$$

$$Y = F_R (\tau\alpha)_n * \frac{F'/R}{F_R} * \frac{\overline{(\tau\alpha)}}{(\tau\alpha)_n} * \overline{Ht} * N * \frac{A_C}{L} \quad (10)$$

#### 4. Performance of solar heating system on the liquid

In the section herein the specifications of the solar heating system, shown in **Figure 1** will have been analyzed applying F-diagram method, solar energy monthly fraction (monthly solar energy contribution), thermal load and annual solar energy contribution. Correlation X, Y and f in the equation form equals to [1].

$$f = 1029Y - 0.065X - 0.245Y^2 + 0.0018X^2 + 0.0215Y^3 \quad (11)$$

where  $0 < Y < 3$  и  $0 < X < 18$ .

Due to the equation nature (11) it should not be used beyond the ranges, shown with curves in **Figure 4**. In case a reference point is out of the range, the chart might be used for extrapolation with satisfactory results [1]. For simplicity, the common method “degree-day” is used for calculating the monthly average load for premises heating necessary for the system in the framework of the research herein. The method of premise heating extent assessment in degrees-days is based on the principle that the need in energy to heat the premises, first and foremost, depends on the temperatures difference: in the premise and outside. It is assumed that monthly load for heating the buildings, premises, in which the temperature is maintained at 24°C is proportional to degree-days amount in a month DD [1].

$$L_S = (UA)h * DD \quad (12)$$

where  $L_S$  is the load for premises heating, and  $(UA)h$  is the multiplication of losses by the building square. For the research the building with  $(UA)h$  467 W/m<sup>2</sup> °C has been taken from the building project. Days amount in degrees (DD) in one

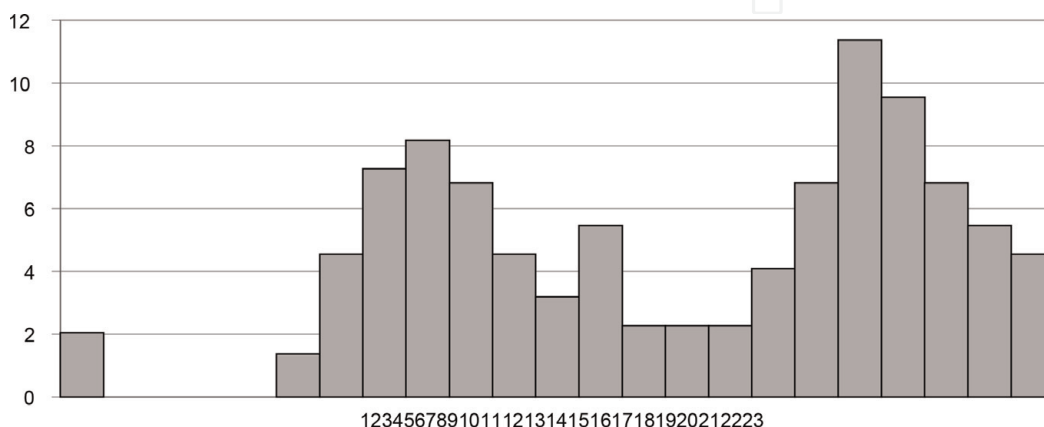

**Figure 4.**  
 Average monthly daily solar radiation for Almaty city.



day is the difference between 18.3°C and average daily atmospheric temperature (average of maximum and minimum atmospheric daily temperature). In case the average daily environmental temperature exceeds 18°C, the number of days in degrees is accepted being equal to zero [5]. For Almaty city the amount of days with a heating degree, monthly average daily solar radiation and environmental temperature are given in **Table 2**.

Another load, included into the research by F-diagram method is the load for water heating for household consumption (amount of energy, necessary for domestic water heating). It much depends on the building inhabitants life style. Average assumed water need and its consumption in Almaty constitutes 300 l per a person per day [1]. Monthly load for water heating,  $L_w$ .

$$L_w = N * N_p * V * (T_w - T_m) * \rho * C_p \quad (13)$$

where  $N$  is the days number in a month;  $N_p$  is the people number in the family;  $T_w$  is the minimal hot water permissible temperature: it is  $\sim 60^\circ\text{C}$  [1],  $V$  is the daily water consumption per a person in  $\text{m}^3$ ,  $T_m$  is the temperature of the main feed water ( $^\circ\text{C}$ ),  $\rho$  is the water density in  $\text{kg}/\text{m}^3$ , and  $C_p$  is the water specific heat capacity ( $4190 \text{ J}/\text{kg} * ^\circ\text{C}$ ). Monthly total load ( $L$ ) represents the total load for the building heating ( $L_s$ ) and loads for household water heating ( $L_w$ ), as in the work [1].

$$L = L_s + L_w \quad (14)$$

Monthly total load fraction, incoming from the solar heating system and water heating, shown in **Figure 1**, is given as a function of dimensionless parameters  $X$  and  $Y$ , defined in Eqs. (1) and (2) and in **Figure 3**. In order to define  $f$ , the heating load share, provided by the solar energy within a month, values  $X$  and  $Y$  are computed for collector and thermal load (**Table 3**). F-value is defined at  $X$  and  $Y$  junction point in **Figure 3**. It is done for every month of the year. Contribution of solar energy for a month is multiplication by total heating load  $L$  for a current month. Share of annual thermal load, provided by solar energy, represents the sum

Month	$\overline{T_a}$ ( $^\circ\text{C}$ )	$\overline{H}$ ( $\text{MJ}/\text{m}^2 * \text{day}$ )
January	-17	-16.0
February	-20	-18.63
March	7	6.2
April	12	10.5
May	18	18.4
June	25	19.0
July	30	20.0
August	28	19.12
September	22	17.00
October	15	13.0
November	7	6.2
December	-10	-9.2

**Table 3.**  
Heating degree and monthly average daily temperature and global radiation in Almaty city.

of solar energy monthly contribution, divided by the annual load, as in the following equation:

$$F = \frac{\sum f_i L_i}{\sum L_i} \quad (15)$$

Let us consider the solar system's heat supply computation method for the conditions, when the hot water supply load is prevailing or the only. Both the pipe water temperature  $T_{x.B}$ , and minimal permissible hot water temperature  $T_r$ . influence at the system's characteristics. As the average working temperature in the system, and consequently, the heat losses from the collector depend on  $T_{x.B}$  and  $T_r$ , it is worth to suppose that expression of  $X$  complex, characterizing the heat loss from the collector, might be updated in the way, to account the impact of  $T_x$ . and  $T_r$ . If to multiply monthly  $X$  values by correction factor, defined by the expression given below, then the F-method of solar heating and hot water supply liquid systems computation can be used for defining the monthly F-values, achieved in the solar hot water supply systems. Correction factor for the hot water supply systems [1].

$$\frac{X_c}{X} = \left( \frac{M}{75} \right)^{-0.25} \quad (16)$$

at

$$37.5 < M < 300.$$

Capacity of the systems with other values can be assessed from F-chart, changing  $Y$  applying the correction factor of the loading heat exchanger  $Y_c/Y$ , as denoted in Eq. (17) or in **Figure 4** [1].

$$\frac{Y_c}{Y} = 0.39 + 0.65e^{(-0.139) \frac{(UA)_h}{\epsilon C_{min}}} \quad (17)$$

at

$$0.5 < \left( \frac{\epsilon L C_{min}}{(UA)_h} \right)$$

## 5. Result and discussion

In this section we discuss the demanded thermal load, fraction of the load, supplied by the solar energy system for various collector zones and parametric researches.

**Figure 5** shows that the chart of monthly values from correction factor by means of F-diagram method shows that the heating extent, monthly average daily temperature and direct solar radiation lower dependent on the weather conditions.

It is clearly seen from **Figure 6** that changed correction factor  $Y_c/Y$  from environmental temperature has an exponential function, which according to a correction factor, increases the annual fraction of the load, provided by the solar energy.

It can be seen from **Figure 7** that the monthly load fraction increases along with the increase of a collector square. It also shows that the monthly fraction is higher in

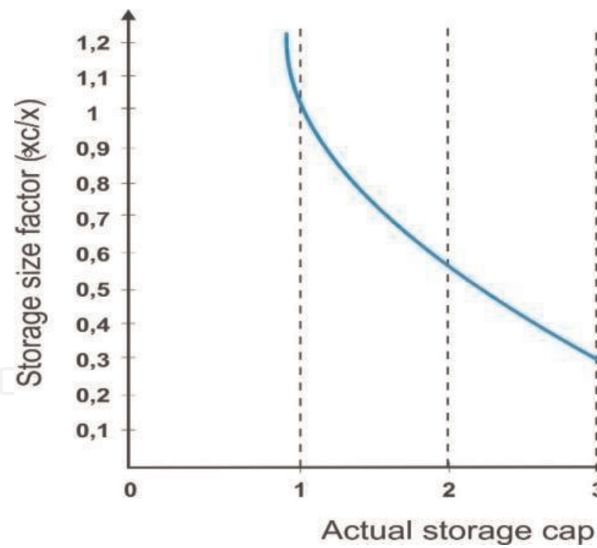

**Figure 5.**  
Dependence of monthly values on correction factor for hot water supply systems.

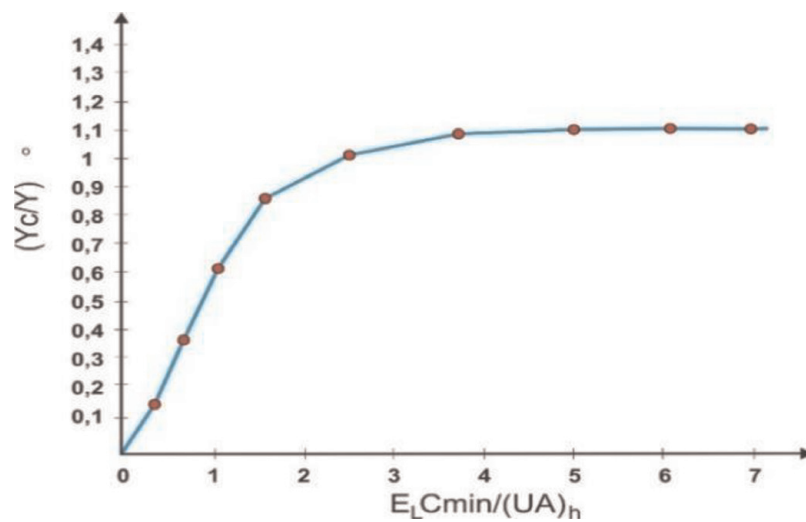

**Figure 6.**  
Dependence of monthly values on the altered correction coefficient  $Y_c/Y$  for hot water supply systems.

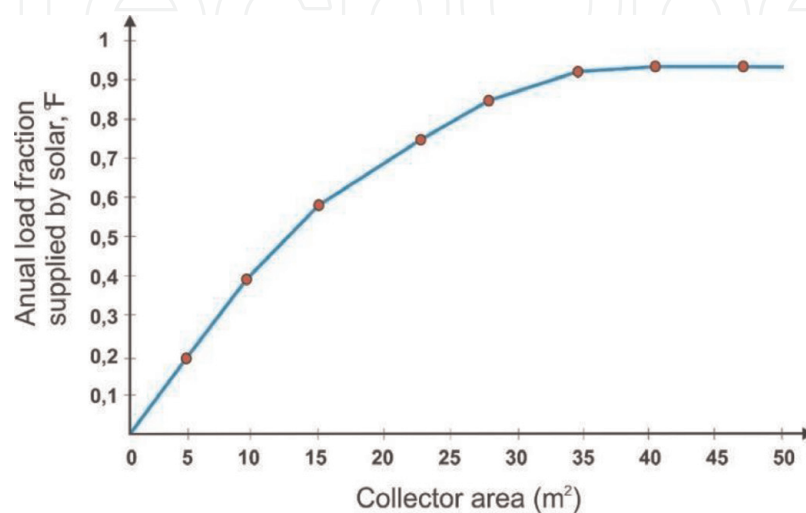
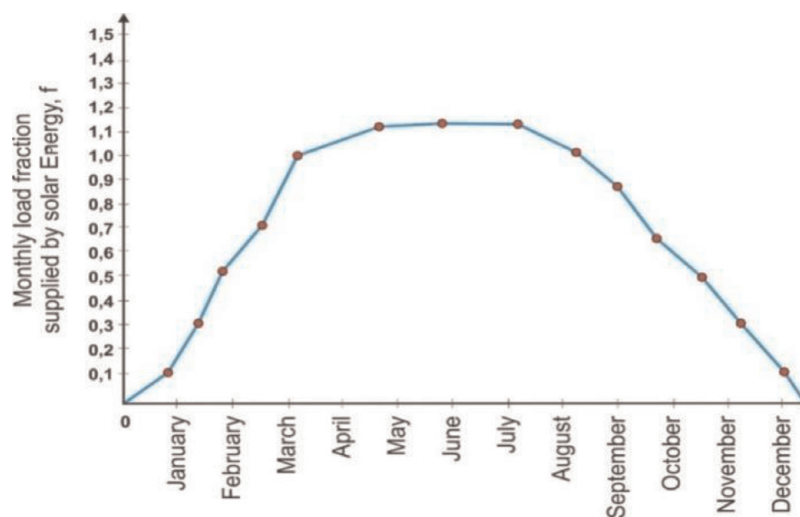

**Figure 7.**  
Dependence of monthly load fraction change on collector's different squares within a year for hot water supply systems.

summer months in Almaty city (Kazakhstan) (July—the highest value) and lower in winter months (January, February—the lowest value).

In **Figure 8** it is observed that the lowest heating load is in the summer months of the year. It is the time, within which the need in heating load is minimal. This figure also denotes that the load for buildings heating is accessible only within 3 months, namely, in December, January and February. In the remaining time the load for heating also equals to zero. It is a very interesting result due to the fact that the load corresponds to the winter peak demand, during which the load for buildings heating is necessary, and the result thereof also provides important advantage from economic point of view at the expense of fuel-electricity total cost reduction that, otherwise, could be spent for the energy, necessary for heat supply, required in winter period.

**Figure 9** shows that the annual load fraction increases for a little and the biggest fraction is in the collector's larger square. In particular, if the storage capacity exceeds approximately 50 l of water per  $m^2$  of collector's square, there is only the insufficient increase (upgrading) in the annual load fraction, provided with the solar energy.



**Figure 8.**  
*Change of premises and hot water heating load depending on the month of the year.*

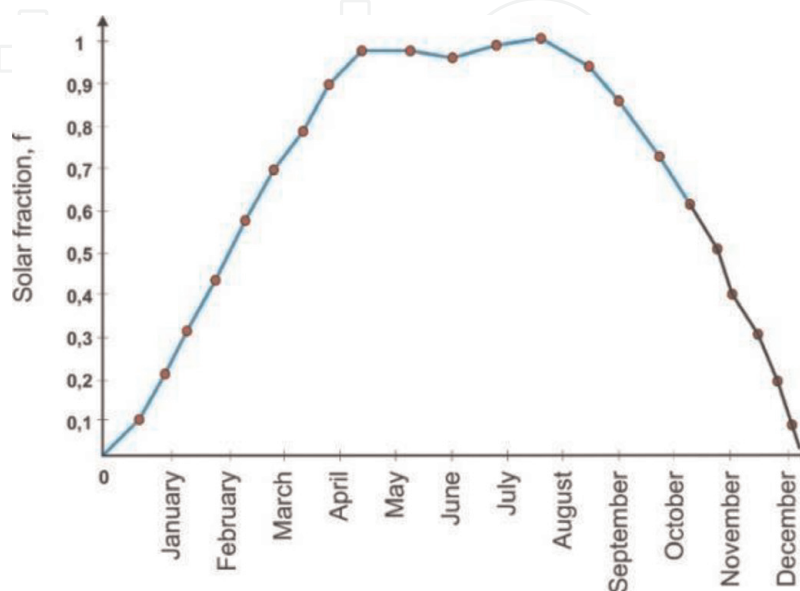

**Figure 9.**  
*Influence of actual storage capacity in liter to  $m^2$  of collector's square per the annual load fraction, provided with the solar energy.*

## 6. Conclusion

In the work herein by means of F-diagram method we have conducted the development of liquid solar heating system and assessment of the total thermal load fraction (load on domestic water and heating), provided by the solar energy for a family of six people in Almaty city (Kazakhstan). Proceeding from the executed research, it appears that, the more a collector's square, the more annual solar energy load fraction. From experimental data it is seen that total solar radiation in summer months is higher, in winter months-lower, as well, by means of F-diagram method it has been computed that the thermal load's peak value is in January, while the minimum load value is in summer months of the year. It proves that the thermal load change is in the phase with the need in thermal load. Due to collector's tilt angles the load increases from minimum value in March and reaches the maximum value in July. It has been defines that for Almaty city (Kazakhstan) the annual optimal angle tilt of collector's configuration, which provides the maximum solar load share comprises about 45°.

## Acknowledgements

The work was supported by the project of the Ministry of Education and Science of the Republic of Kazakhstan No. 055236693; Contract No. 318 of March 30, 2018

### Author details

Yedilkhan Amirgaliyev, Murat Kunelbayev\*, Aliya Kalizhanova, Ainur Kozbakova, Salauat Daulbayev, Timur Merembayev and Didar Yedilkhan  
Institute Information and Computational Technologies CS MES RK, Almaty, Kazakhstan

\*Address all correspondence to: [murat7508@yandex.kz](mailto:murat7508@yandex.kz)

### IntechOpen

© 2019 The Author(s). Licensee IntechOpen. This chapter is distributed under the terms of the Creative Commons Attribution License (<http://creativecommons.org/licenses/by/3.0>), which permits unrestricted use, distribution, and reproduction in any medium, provided the original work is properly cited. 



## References

- [1] Duffie JA, Beckman WA. Solar Engineering of Thermal Processes. 4th ed. Hoboken, New Jersey: John Wiley & Sons, Inc; 2013
- [2] Liu Y-M, Chung K-M, Chang K-C, Lee T-S. Performance of thermosyphon solar water heaters in series. *Energies*. 2012;5:3266-3278. DOI: 10.3390/en5093266
- [3] Dickinson EW. Solar Energy Technology Handbook. CRC Press/Taylor and Francis; 2018. pp. 12-42
- [4] Bloss WH, Pfisterer F. Advanced in solar energy technology. In: Proceedings of the Biennial Congress of the International Solar Energy Society; Hamburg, Federal Republic of Germany; September 13–18, 1987. Elsevier; 2013
- [5] Koce A, Atmaca I, Ertekin C. A comparison of flat plate and evacuated tube solar collectors with f-chart method. *Journal of Thermal Science and Technology*. 2015;35(1):77-86
- [6] Kalogirou S. Solar Energy Engineering: Processes and Systems. Elsevier; 2009
- [7] Amirgaliyev YN, Kunelbayev M, Wójcik W, et al. Solar-driven resources of the Republic of Kazakhstan. *News of the National Academy of Sciences of the Republic of Kazakhstan, Series of Geology and Technical Sciences*. 2018; 3(430):18-27
- [8] Amirgaliyev Y, Kunelbayev M, Wójcik W, et al. Calculation and selection of flat-plate solar collector geometric parameters with thermosiphon circulation. *Journal of Ecological Engineering*. 2018;19(6): 176-181
- [9] Amirgaliyev Y, Kunelbayev M, Kalizhanova A, Auelbekov O, Katayev N, Kozbakova A. Theoretical and mathematical analysis of double circuit solar station with thermo siphon circulation. *Journal of Polytechnic-Politechnik Dergisi*. 2019;22(2):485-493