

We are IntechOpen, the world's leading publisher of Open Access books Built by scientists, for scientists

4,800

Open access books available

122,000

International authors and editors

135M

Downloads

Our authors are among the

154

Countries delivered to

TOP 1%

most cited scientists

12.2%

Contributors from top 500 universities



WEB OF SCIENCE™

Selection of our books indexed in the Book Citation Index
in Web of Science™ Core Collection (BKCI)

Interested in publishing with us?
Contact book.department@intechopen.com

Numbers displayed above are based on latest data collected.
For more information visit www.intechopen.com



Smart Environment Monitoring System Using Wired and Wireless Network: A Comparative Study

Tabbsum Mujawar and Lalasaheb Deshmukh

Abstract

This chapter focuses on the implementation of a smart environment monitoring system using wired and wireless sensor networks (WSN). The goal was to develop a LabVIEW based system to monitor environmental parameters that provide inaccessible, real-time monitoring. The development of portable and efficient environment monitoring system based on LabVIEW GUI that monitors various environmental parameters such as temperature, relative humidity, Air quality and light intensity was developed. This chapter targets on both wired and wireless approach for environment monitoring. The limitations of wired network were explained by flourishing the portable system. For proceedings with the impediment and insufficiency of wired network, Arduino augmentation ascendancy, are mingled with XBee wireless sensor network. The data from the environment was sent to the sink node wirelessly through mote. Monitoring of the data was done in a personal computer (PC) through a graphical user interface made by LabVIEW. The pertinent sensor for each was connected to analog input of Arduino UNO and their values are displayed on front panel of LabVIEW. LabVIEW run time engine makes the system cost effective and facile. To reveal the effectiveness of the system, some measurement results are also predicted in this chapter.

Keywords: wired network, wireless sensor network, LabVIEW, web publishing tool

1. Introduction

Environment monitoring plays an important role in all the sectors. It is a forthcoming relevance field which is of fastidious rate to our country. Metropolitan cities with superior absorption of industry, rigorous transportation and soaring population mass are major sources of air pollution, which results in monitoring of environment. To think about the environment, it has turned out to be one of the prime concerns for almost every country in the world. Due to enormous increased in industrialization, the recent condition is obviously altering towards more environment gracious solutions.

This chapter discusses the different environmental and air quality parameters using respective sensors for it and provides various opportune services for users who can administer the information via a website from long-distance. This system comprises of both wired and wireless networks. Wired communications is a wide name used to portray the communication process that utilizes the cables and wiring to convey the data. Usually, wired communications are appreciated widely by research community due to its stability in services. They are not influenced

by external environmental effects as compared to wireless networks. For some services, the potency and pace of the communication is finer to other solutions, such as satellite. Due to this distinctiveness, wired connections linger trendy, yet wireless system sustained to proceed. Environment monitoring with wired network have some limitations such that wired sensors could not be implemented in remote areas. Also it is very complex and costly to mount and sustain the wired networks [1]. Additionally, if a wire between the two devices gets breaks, the communication between these two gets collapsed; hence, the entire network will also fail.

Letter the initiative of replacing the wired with wireless network was brought and it overcomes approximately all the troubles with the wired communication nevertheless it hold disadvantages of the sluggish bandwidth and growth of interference. Wireless communications is a rapidly increasing technology endow with the litness and mobility in our environment. The noticeable benefit of wireless transmission is a key diminution and simplification in wiring. The cabling cost in industrial installations is 130–650 US\$ per meter and using wireless technology, it would be eradicated around 20–80% [1]. The skillful organization of the equipment through efficient monitoring of the environment augments an additional hoard in terms of cost, e.g., Wang et al. [2]. The wireless system developed by Honeywell to scrutinize steam traps saves the total cost effectively about 100,000–300,000 US\$ annually [2]. The impracticable sensor applications' technology, viz. monitoring far-off areas and locations, is featured with unrestricted mechanism and litness for sensors and augmented the network heftiness. Moreover, WSN technology makes the system reliable and less costly. It allows more rapidly exploitation and deployment of different sensors because this network provides various properties to the sensor nodes. Further, an integration of WSN technology with MEMS makes the motes with enormously stumpy cost, miniature sized and least power. MEMS are the inertial sensors, pressure sensors, temperature sensors, humidity sensors, strain-gage sensors and various piezo and capacitive sensors for proximity. Over the last decade, the technology of wireless sensor network (WSN) has been widely used in many real time applications and these miniaturized sensors can sense, process and communicate. Most wireless sensor nodes are capable of measuring temperature, acceleration, light, illumination, humidity; level of gases and chemical materials in the surrounding environment.

WSN is a compilation of wireless sensor nodes. A WSN is also an amalgamation of an integer of motes with limited communication ability. The co-ordination between the sensor nodes provides ability to process and to gather information in a large amount [3, 4]. Also, ad-hoc networks can be created. Generally, WSN networks are categorized in two types: structured and unstructured. In unstructured WSN, the sensor nodes are deployed in an ad-hoc manner without any careful planning. Once nodes are deployed, monitoring and processing of data is done in unattended environment. In structured WSN, motes are deployed in preplanned approach. The structured wireless sensor network is superior to unstructured one, because cost and maintenance required to deploy the node are less. The nodes in structured WSN are positioned at exact locations to offer coverage, whereas unstructured deployment has uncovered areas. Wireless sensor network aims to give co-ordination among the physical conditions and the internet globe. It has the following features:

- WSN should be reliable
- More accurate
- Flexible in nature

- Cost effective
- Easy to install.

Tilak et al. [5] have shown that the intellectual sensors can gather data from disaster area, floods and also from revolutionary attacks. The network is promising for

- Collection of information
- Dealing out of information easily and
- Environment monitoring for numerous applications.

Due to the above compensation WSN becomes vital part of near future applications.

By using WSN based environmental monitoring system it is possible to transform the customarily environmental monitoring methods. Conventionally data loggers were used to collect the data from environment and this was time over-riding and fairly costly. To avoid the drawbacks of this system, we developed a system which is portable and cost effective. The LabVIEW (Laboratory Virtual Instrument Engineering Workbench) and an Arduino IDE are the programming tools used for this system. But, the writing programming is mostly used in Arduino [6]. Meanwhile, LabVIEW uses a programming type of block diagram. In the present system, it is decided to use the Arduino platform or microcontroller for the deployment of WSN nodes. This is an embedded board having included USB competence. The miniature and user responsive nature makes it more superior than other advanced microcontrollers. These microcontrollers have more on chip facilities such as +5 V, analog and digital pins. It does not have on board power jack. Due to the auto switching capability of ATmega 328 microcontroller, no external power jumpers are required. The use of an Arduino simplifies the process of working with microcontrollers and additionally it offers some advantages to the users over other systems such as cross-platform, simple, clear programming environment, open source and extensible software and hardware. Arduino platform has good specifications e.g. cheap, easy to use and wide varieties of shields that have been emerged with many different purposes such as Ethernet and GSM support. While, if we want to create a multifunction code for carrying out on multicore processors this would be possible using LabVIEW tool. It has a graphical palette to create and run VI's. Any complex programming can be done easily using the tools available in this software. This environment monitoring system uses the web publishing tool to display the monitored data on the web page for remote monitoring. In this chapter, we studied both wired and wireless environment monitoring system.

2. Literature survey

To endeavor with the environment monitoring, momentous accomplishment was born out in shrewd and diminish this technique. The manifestation of environment monitoring and WSN related facts are premeditated by a lot of investigator and have proclaimed demographic data incidents. In 2008, Yang et al. [7] disclosed, "An Environmental Monitoring System with Integrated Wired and Wireless Sensors" fixate a novel environmental monitoring system with a concentrate on the comprehensive system planning for smooth alliance of wired and wireless sensors for long-term, inaccessible monitoring. A consolidated plan for sensor data assembly, execution, promulgation was also presented in this paper.

In 2009, Flammini et al. [8] reported, “Wired and wireless sensor networks for industrial applications” noted a real-time sensor networks for industrial applications. Particular consideration has been compensated to the explanation of arrangements and avenue for completion evaluation was conferred. This paper represents the limitations of wired network and how it is overcome by wireless sensor network.

Kaur et al. [9], in 2014, narrated, “Comparisons of wired and wireless networks: A review”, revealed the resemblance between wired and wireless networking on the basis of disparate hardware demand, ranges, flexibility, accuracy and assets. Wired and Wireless networks are more trivial in the private sectors as well as in the household applications. The wired networks administer a defended and swift connectivity but the need of movability, i.e., in any place, anytime is sway the network users close to wireless technology.

3. Wired communication technology

The general block diagram of wired environment monitoring system is shown in **Figure 1**.

This system helps to make the cities pollution free. It monitors the contaminant air and informs about the level of pollution in the air. The wired approach of the system consists of SY-HS-220 humidity sensor, MQ-135 air quality sensor, LDR, LM-35 temperature sensor etc. These sensors output are connected at analog inputs of an Arduino microcontroller. All these sensors are placed over the area to detect the different levels of pollution. The system also makes use of Arduino module, LCD, buzzer and LED's. The LCD screen is used to display the level of pollution within Solapur University campus. It exhibits the category of pollution level. The system puts on buzzer when the level of pollution crosses its threshold limit. Thus this system helps to keep the Solapur University campus pollution free by informing about pollution levels of the areas. This system cost effective and portable. The circuit set up for wired system and its connections are shown in **Figure 2**. The system using wired network is portable and effective. But, drawback of such a system is that cables requirement for providing linkage between the devices. As number of

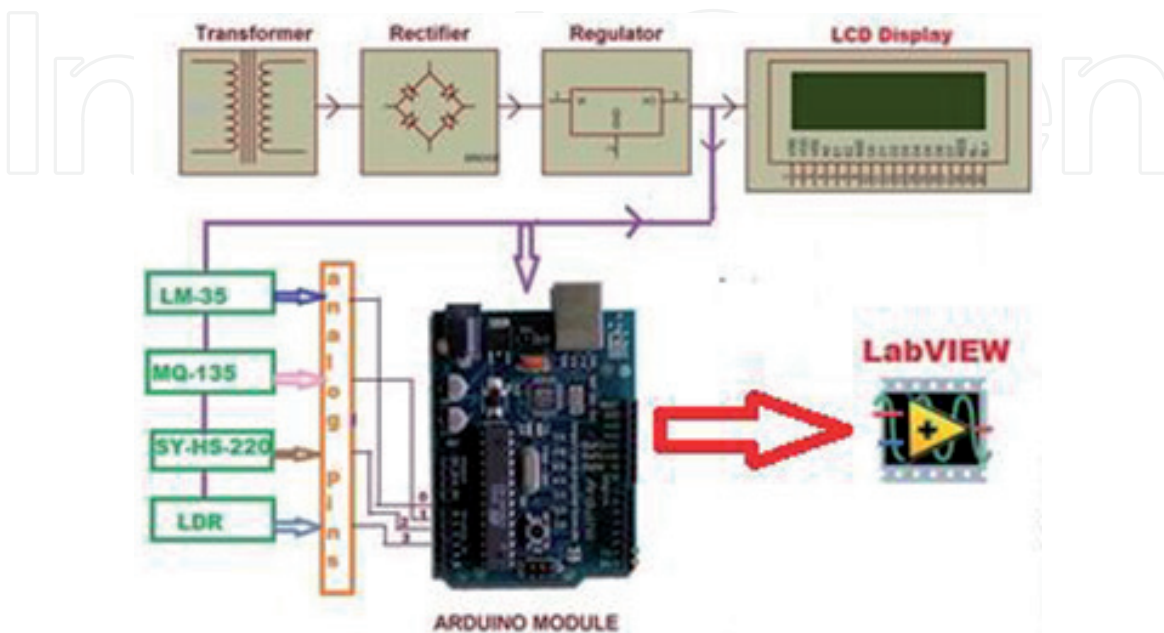

Figure 1.
General block diagram of wired system.

peripheral increased in the system, it leads to lofty installation and protection costs, e.g., due to low scalability and more breakdown rate of connectors. Consequently, wireless technology is the best solution for today's (Figures 3 and 4).

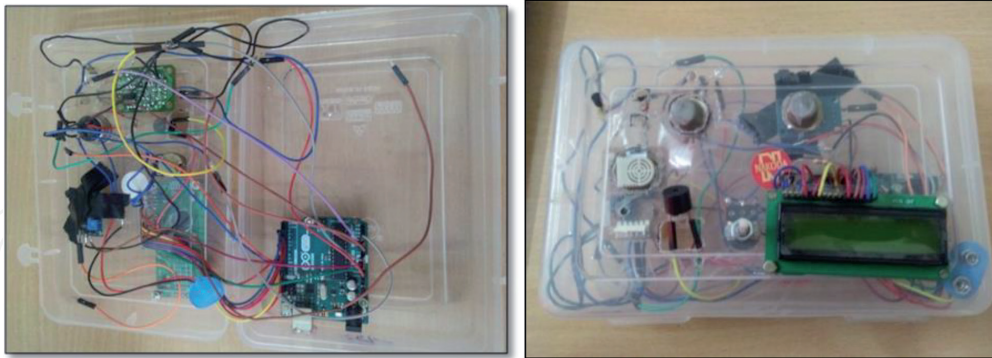

Figure 2.
Circuit connection of a system.

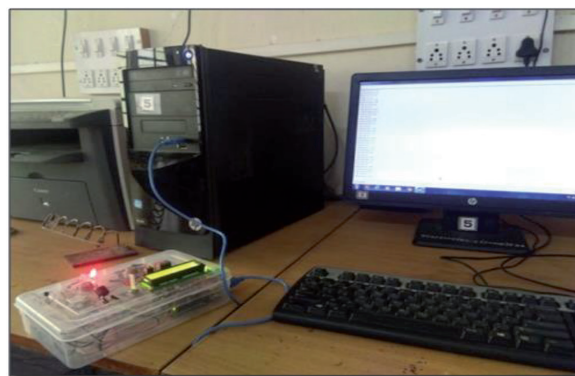

Figure 3.
Experimental set up for wired environment monitoring system.



Figure 4.
Actual readings of each sensor on LCD.

4. Wireless communication technology

Due to advancement in technology wireless network being used to avoid cabling cost and to obtain efficient control. We proposed to use WSN technology for it. In today's world, the wireless sensor networks (WSN) is one of the most momentous technology. The monitoring, reorganization and controlling of the data are the key

concern of this technology. The inaccessible interface and actual monitoring with the physical world can be done easily by sensor node of the network. The wireless sensor networks differ from general data networks, because WSN are application oriented, planned and deployed for dedicated purpose [10].

The whole system was designed using ATmega 328 microcontroller integrated with XBee S2 protocol to form sensing phenomena. The planning of mote consists of a processing entity conscientious for compilation and giving out the data sensed by a sensor. A radio transceiver mechanism used as a communication part accompanied by the sensors and a battery is the power provide unit in this system. We anticipated four sensors for measuring temperature, humidity, air quality and light intensity within Solapur University campus. The humidity SY-HS 220 sensor module is used for measuring humidity. Its operating voltage and temperature is 5 V, 0–60°C. The –30 to 85°C is storage temperature range of this module. It converts relative humidity to voltage and can be used in environment monitoring applications. LDR sensor and its voltage divider circuit were used to measured light intensity. LM 35 temperature sensor gives 10 mV per 1° rise in temperature. While, MQ-135 performs ambient air quality monitoring. The circuit connection of sensors to Arduino is shown in **Figure 2**. The developed WSN system uses two motes and one sink node.

The general block diagram of wireless environment monitoring system is shown in **Figure 5**.

According to **Figure 5**, working of the proposed system is carried out. Initially, we have calibrated the individual sensors and then connected to analog inputs of an Arduino microcontroller. This controller integrated with 10-bit ADC, which renovate the analog signals into digital output (**Figures 6 and 7**).

The results are displayed on the serial monitor window of Arduino. Through VISA function tool, it is displayed on the front panel of the LabVIEW. For this, we used LabVIEW run time engine, which means that without installation of LabVIEW on your computer, you can run any LabVIEW program, which reduces cost of the system. The developed GUI (Graphical User Interface) using LabVIEW for system continuously monitors the environment data [11]. In X-CTU software, individual ID's for each motes are specified [12–14] (**Tables 1 and 2**).

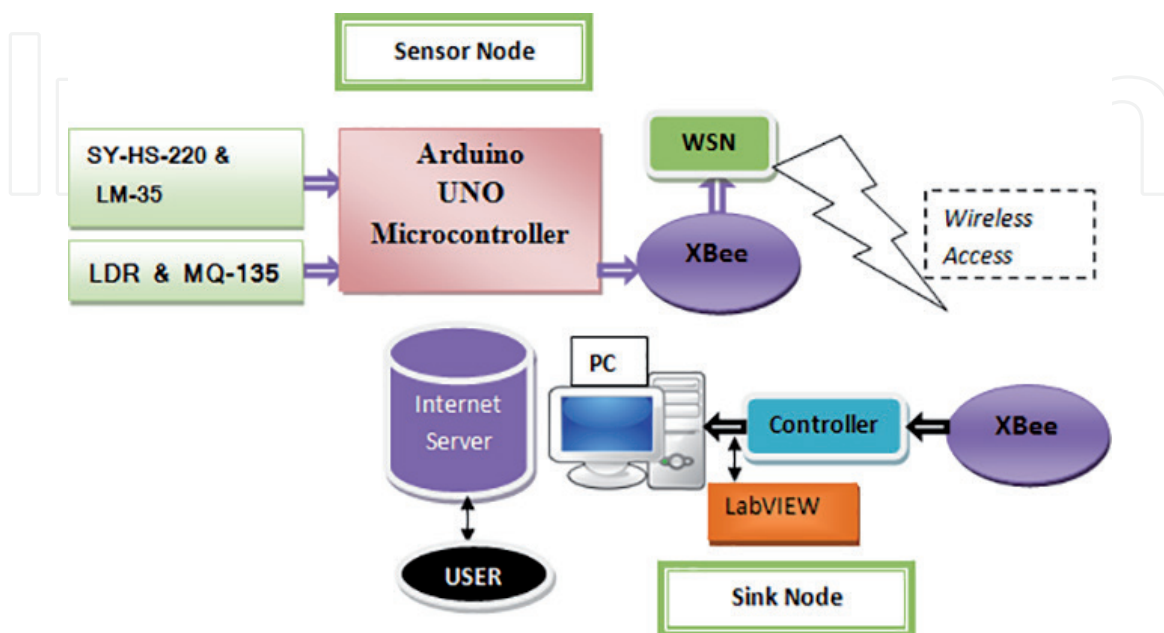

Figure 5.
General block diagram of wireless system.

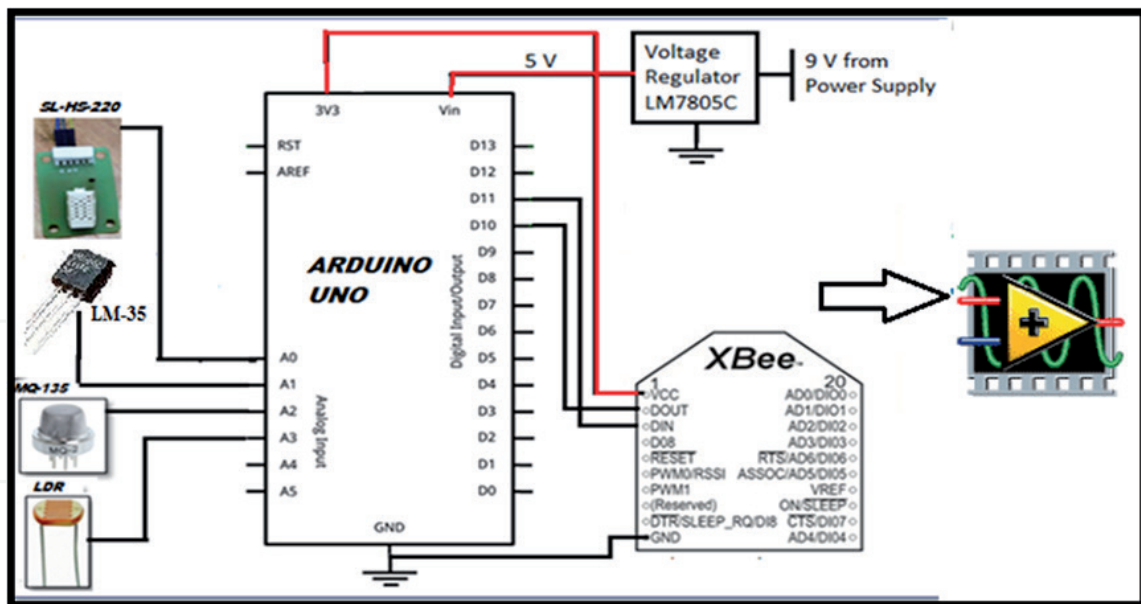

Figure 6.
 Circuit connection of sensor node.

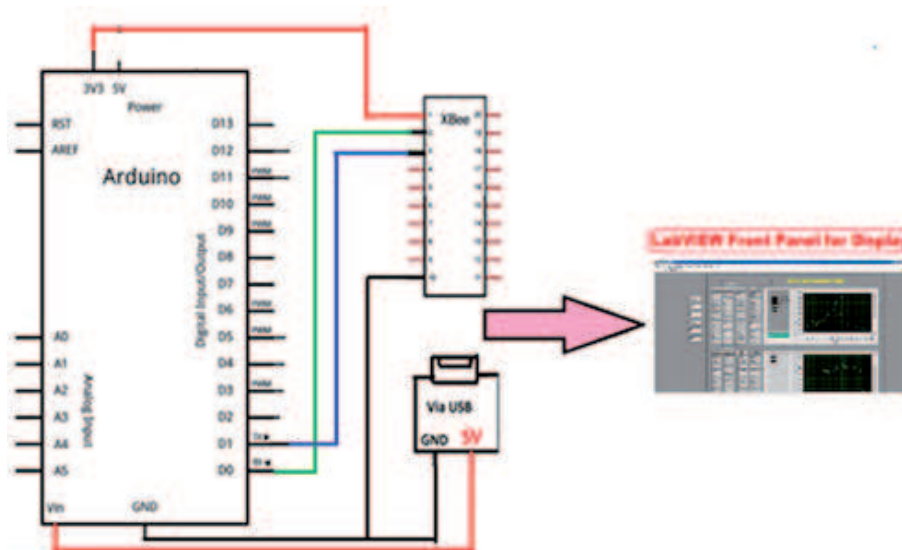

Figure 7.
 Circuit connection of sink node.

The data from each mote was separated using LabVIEW software as follows:

- The sink node (Arduino UNO board) was interfaced to LabVIEW through VISA (Virtual Instrument Software Architecture),
- Sink node is a common receiver, which receives data from several motes,
- After this division of the data was carried out.

The LabVIEW GUI was used to monitor the environment quality level. LabVIEW is scheme-intend software that allows to program tools on a GUI for the measurement and control of the systems.

LabVIEW is a graphical improvement tool developed by a National Instruments. These tools are very interactive and superficial for encoding. We can amend the

Sr. no.	Parameters name	Parameters symbol	Configuration value
1.	PAN ID	ID	100
2.	Destination address high	DH	0
3.	Destination address low	DL	0
4.	Scan channel	SC	FFFF(Hex Value)
5.	Scan duration	SD	3
6.	Channel verifications	JV	1
7.	Device option	D0	1
8.	Node identifier	NI	Node 1 to Node 2
9.	Node join time	NJ	FF(Hex Value)
10.	Node discovery back off	NT	3C
11.	Power level	PL	4
12.	Power mode	PM	1
13.	Power at PL4	PP	3
14.	Baud rate	BD	3
15.	RSSI PWM timer	RP	28
16.	DI07 configuration	DI07	1
17.	DI06 configuration	DI06	0
18.	IO sampling rate	IR	3E8
19.	Parity	NB	0
20.	RSSI of last packet	DB	0

Table 1.
XBee parameter for router.

Sr. no.	Parameters name	Parameters symbol	Configuration value
1.	PAN ID	ID	100
2.	Destination address high	DH	0
3.	Destination address low	DL	0
4.	Scan channel	SC	FFFF(Hex Value)
5.	Scan duration	SD	3
6.	Channel verifications	JV	0
7.	Device option	D0	1
8.	Node identifier	NI	—
9.	Node join time	NJ	FF
10.	Node discovery back off	NT	3C
11.	Power level	PL	4
12.	Power mode	PM	1
13.	Power at PL4	PP	3
14.	Baud rate	BD	3
15.	RSSI PWM timer	RP	28
16.	DI07 configuration	DI07	1

Sr. no.	Parameters name	Parameters symbol	Configuration value
17.	DI06 configuration	DI06	0
18.	IO sampling rate	IR	3E8
19.	Parity	NB	0
20.	RSSI of last packet	DB	0

Table 2.
XBee parameter for coordinator.

indoctrination gush as we want. The proficient machine code is the distinctive chattels of LabVIEW. The developed G-code of LabVIEW is more indulgent and required execution time is less. The freeware driver makes it more intuitive. The communication, instrumentation, neural networking, control system etc. tools in the LabVIEW have its own task to engender G-code relating to this. The current wireless system uses web publishing tool to show the monitored information on the web page for distant monitoring.

5. Results

When sensor nodes are placed within Solapur University campus, it continuously monitors an environment, the readings from each sensor node will send to the gateway node. This gateway node will send the data to LabVIEW through VISA. The graphical representation of sensor node 1 and sensor node 2 are depicted in the **Figures 8** and **9**.

Figure 10 represents the GUI crated by LabVIEW for environment monitoring system.

The LabVIEW programming for this was done as follows (**Figure 11**).

For real time monitoring of environment system, we used a web publishing tool in LabVIEW. This tool was used for web portal connectivity to cover stout monitoring vicinity.

By accessing the web server, inaccessible monitoring and controlling of this system was done using a web publishing tool. Based on the parameters

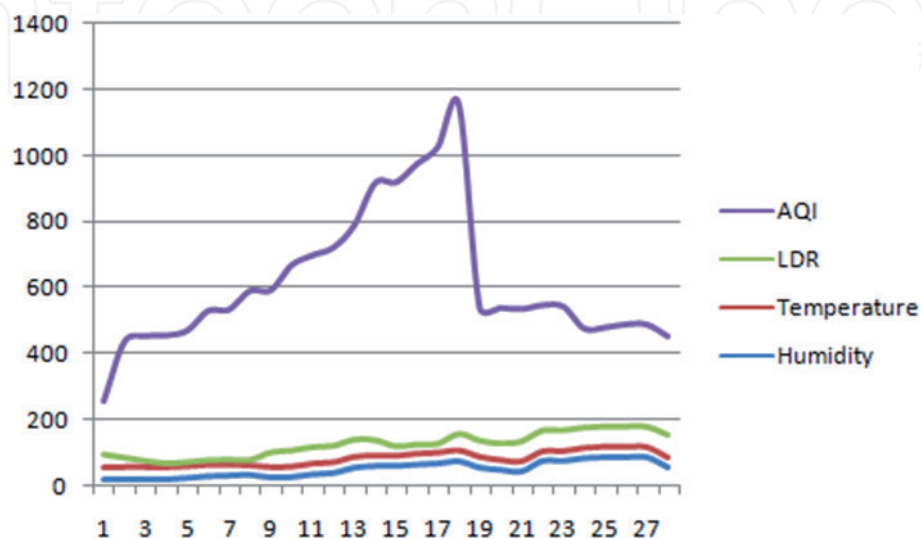

Figure 8.
Graphical representation of sensor node 1.

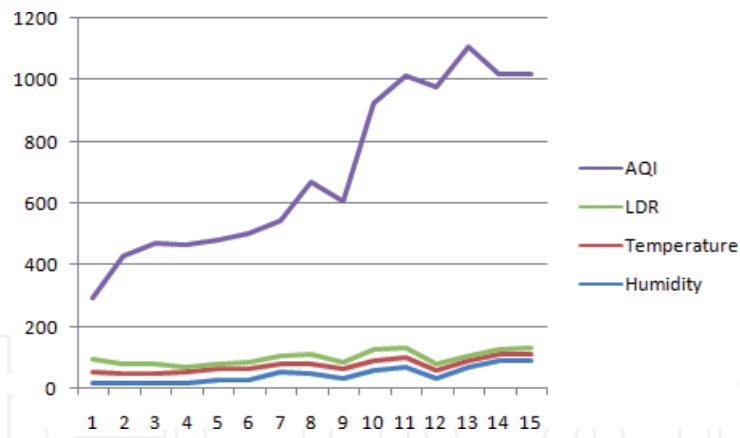

Figure 9. Graphical representation of sensor node 2.



Figure 10. GUI of monitoring environmental parameters of sensor nodes.

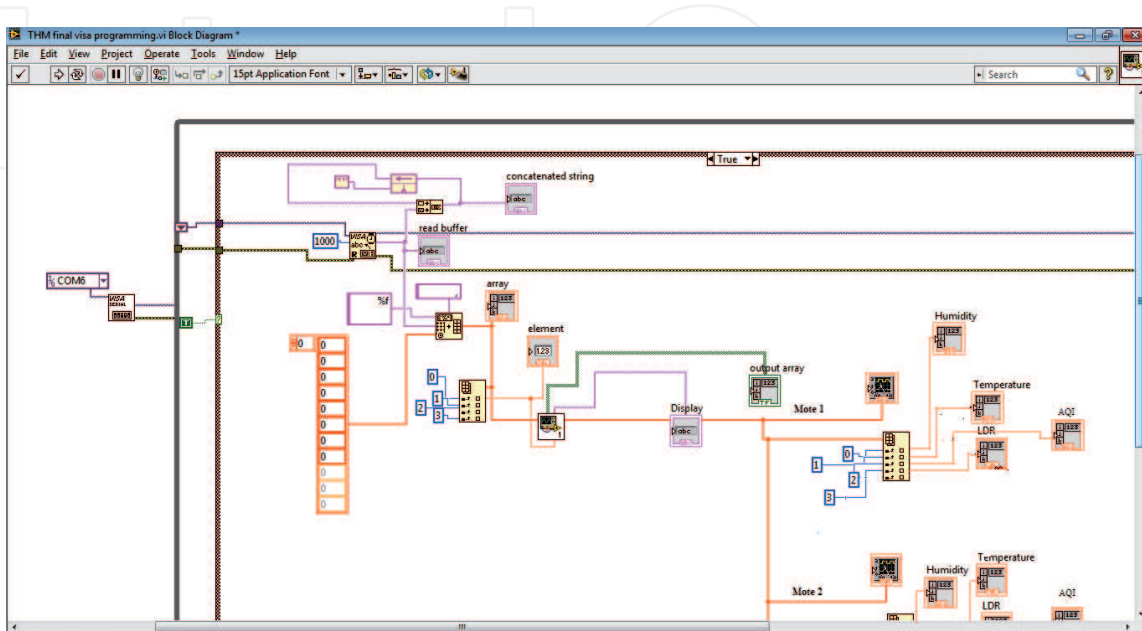

Figure 11. The G-code for sensor nodes for environment monitoring.

specified in the program, this tool converts the front panel into HTML web page. **Figure 13** represents the GUI of the web server. Concisely, we built an effort-less VI that monitors the wireless system. This application was launched on the internet and monitored it tenuously and controlled it involuntarily. For initiation this application on the internet, we must have to arrange the web access. Port address of LabVIEW is 8000. By enabling the various setting in a web publishing tool, we have a right of entry to access other unapproachable panel server and all other IP addresses which we desire. The URL obtained from the LabVIEW page is <http://dell-pc:8000/intecopen.html>. **Figure 12** shows the data monitoring system in the internet browser before putting a control over VI. When we put a control over VI, it is shown in **Figure 13**. The internet browsing of a system helps to monitor an environment quality at remote places continuously to the users. It is shown in **Figure 14**.

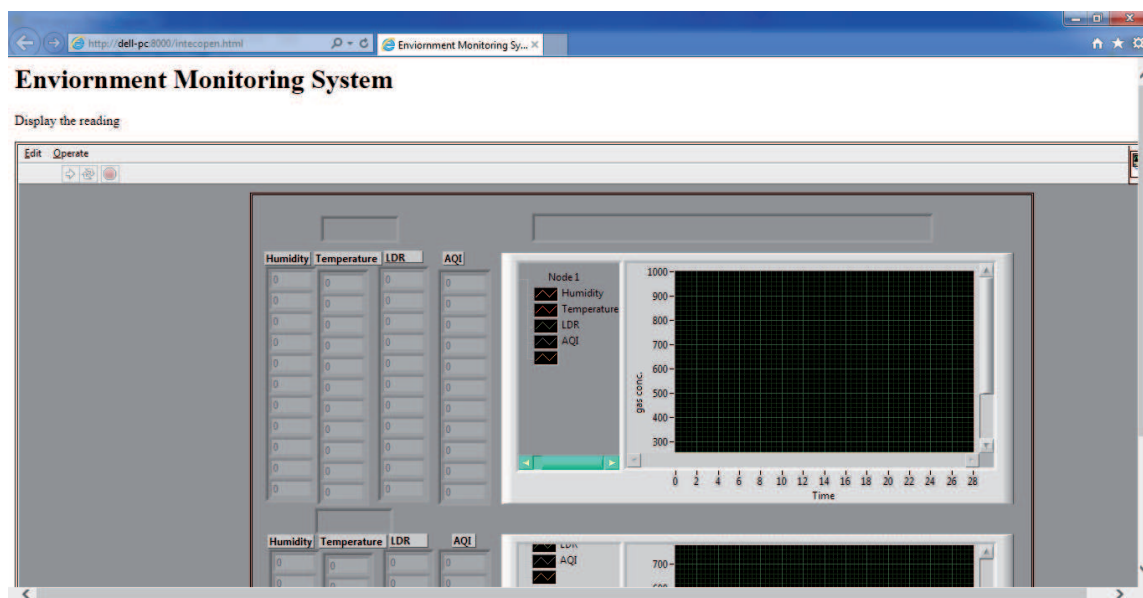

Figure 12.
The GUI of a system displayed on the web server before putting control over VI.

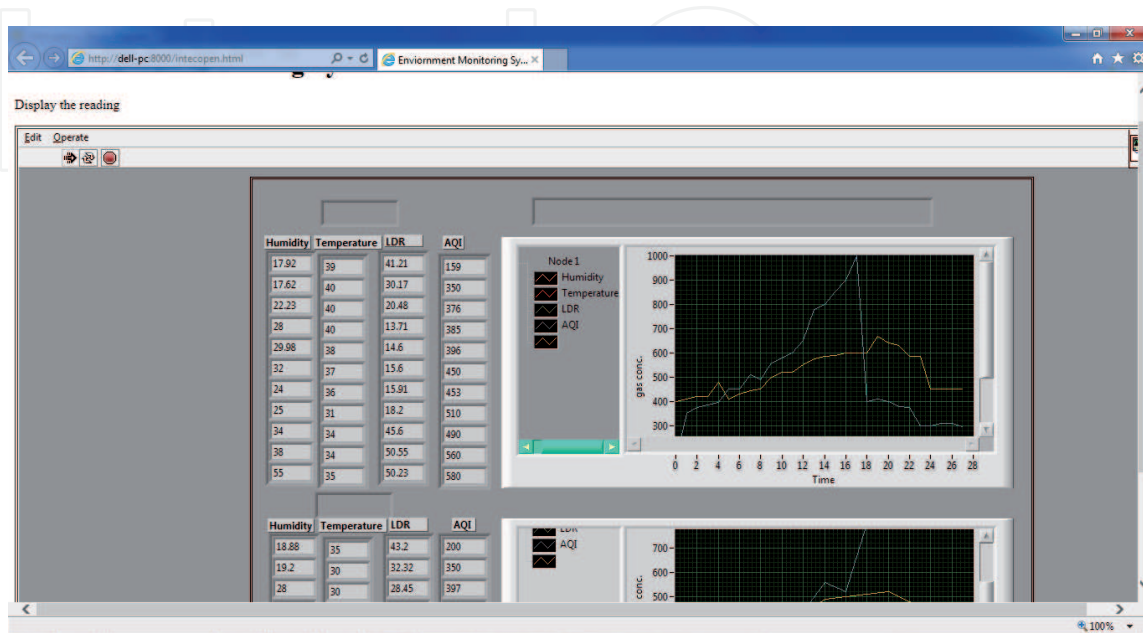

Figure 13.
Distant monitoring of a system after putting control over VI.

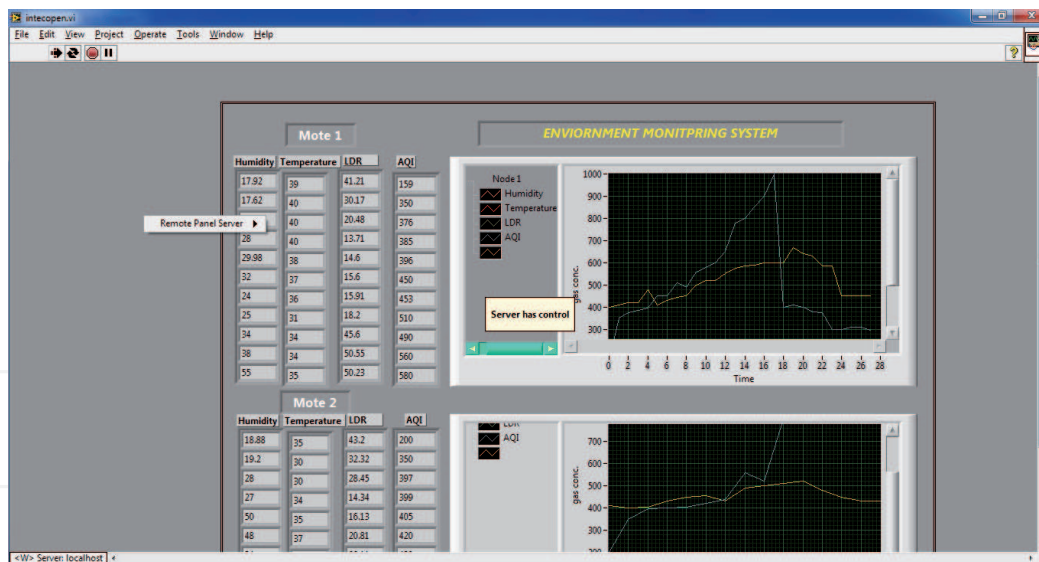

Figure 14.
Front panel showing remote monitoring of a system.

6. Conclusions

A lucrative environmental monitoring method with least amount of components has been constructed. The system is successfully developed using wired and wireless networks. The limitations of wired network and opportunities using wireless networks are rigorously described. The environment monitoring sensors with an Atmega 368 microcontroller, Web portal is proposed. For sending and receiving of the data, the web publishing tool in LabVIEW is used. The system is developed using two motes and one sink node. XBee protocol is used to provide wireless access. This system provides a real-time monitoring via money-spinning low data rate and significant power wireless communication technology. We envisage that this system will encompass an enormous recognition in the industrialized sectors and will realize an effective amalgamation among WSN and Web portal. Accordingly, a tack target of inaccessible monitoring of the air quality within the environment can be attained. It is highly pertinent to metrological departments and also in industrial sectors. In future, we would be fond of to be made controlling system for environment monitoring.

Author details

Tabbsum Mujawar* and Lalasaheb Deshmukh
School of Physical Sciences, Solapur University, Solapur, Maharashtra, India

*Address all correspondence to: thmujawar@sus.ac.in

IntechOpen

© 2019 The Author(s). Licensee IntechOpen. This chapter is distributed under the terms of the Creative Commons Attribution License (<http://creativecommons.org/licenses/by/3.0>), which permits unrestricted use, distribution, and reproduction in any medium, provided the original work is properly cited. 

References

- [1] Mujawar T. Development of wireless sensor network for hazardous gas detection and alert system [thesis]. In: Inlibnet. 30 Jan 2017. Available from: <http://www.shodhgang.inlibnet.ac.in>
- [2] Wang N, Zhang N, Wang M. Wireless sensors in agriculture and food industry. Recent development and future perspective. *Computers and Electronics in Agriculture*. 2006;**50**:1-14
- [3] Suryadevara N, Mukhopadhyay S. Wireless sensor network based home monitoring system for wellness determination of elderly. *IEEE Sensors Journal*. 2012;**12**:1965-1972
- [4] Tiantian J, Zhanyong Y. Research on mine safety monitoring system based on WSN. *Procedia Engineering*. 2011;**26**:2146-2151
- [5] Tilak S, Ghazaleh N, Heinzelman W. A taxonomy of wireless micro sensor network nodes. *ACM SIGMOBILE Mobile Computing and Communications Review*. 2002;**6**:28-36
- [6] Margolis M. *Arduino Cookbook*. 1st ed. Massachusetts, United States: O'REILLY® Media, Inc.; 2011. pp. 81-213
- [7] Yang J, Zhang C, Li X, Huang Y, Fu S, Acevedo M. An environmental monitoring system with integrated wired and wireless sensors. In: *International Conference on Wireless Algorithms, Systems and Applications*; 2008;**3**:224-236
- [8] Flammin A, Ferrari P, Marioli D, Sisinni E. Wired and wireless sensor networks for industrial applications. *Microelectronics Journal*. 2009;**40**:1322-1336
- [9] Kaur N, Monga S. Comparisons of wired and wireless networks: A review. *International Journal of Advanced Engineering Technology*. 2014;**2**:34-35
- [10] Mujawar T, Kasbe M, Mule S, Deshmukh L. Development of wireless gas sensing system for home safety. *International Journal of Engineering Sciences & Emerging Technologies*. 2016;**8**:213-221
- [11] Mujawar T, Kasbe M, Mule S, Deshmukh L. Online monitoring of WSN based air quality monitoring system. *AIP Conference Proceedings*. 2018;**02003**:020030-1-020030-9
- [12] Schell M, Guvench M. Development of a general purpose XBee series-2 API-mode communication library for LabVIEW. In: *Northeast Section Conference (ASEE)*; April 27-28, 2012
- [13] Zhang J, Song G. Design of a wireless sensor network based monitoring system for home automation. In: *International Conference on Future Computer Sciences and Application*. June 2011;**7**:18-19
- [14] Li Y, Ji M. Design of home automation system based on ZigBee wireless sensor network. In: *1st International Conference on Information Science and Engineering (ICISE)*; December 26-28, 2009